



Quality at Every Turn  
TECHNICAL CATALOG



DESIGNERS AND MANUFACTURERS OF PRECISION MOTION CONTROL PRODUCTS

CGI, INC. • 3400 Arrowhead Drive • Carson City, Nevada 89706  
Tel 775.882.3422 • Fax 775.882.9599 • [www.cgimotion.com](http://www.cgimotion.com)



## Precision Made in America

Quality, reliability and being customer-driven makes CGI the best value for your motion control requirements.

CGI, Inc.'s core business is manufacturing precision motion control solutions. From 1967 to present, CGI's comprehensive technical knowledge, manufacturing expertise and "can-do" attitude has served the needs of an ever changing motion control marketplace. CGI's diverse customer base and wide range of applications in aerospace, assembly, automotive, coordinate measuring, machine tool, material handling, medical, packaging, pharmaceutical, robotics, semi-conductor, special machinery, telecommunications and textile have earned CGI a reputation for innovation, quality and service.

CGI designs and builds high quality gearheads for AC induction motors, permanent magnet DC motors, servomotors and servomotors. CGI can supply a complete motion control package, consisting of encoders, gearmotors, motion controllers, etc., to meet your application's requirements. From the simple to the complex, CGI can supply off-the-shelf products or provide a custom-fit solution.

CGI, Inc. operates under an ISO9001:2000 certified quality management system. CGI's Engineering, Manufacturing and Quality departments employ the latest systems available, such as Solidworks with FE analysis, AutoCad, CAD/CAM, Visual Manufacturing with ERP inventory management and CMM technology. We continually strive for new ways to improve standard products as well as minimize the time from the design stage to completion of your new and custom products.

CGI's greatest asset is its people! That is how CGI has accomplished an excellent record for on-time deliveries, rush/emergency production and customer satisfaction that is known throughout the industry. CGI is dedicated to exceeding those levels of support, satisfaction and product quality.

### INTRODUCTION

#### COMPANY AND PRODUCT OVERVIEW

2-3

### INLINE GEARHEADS

#### PL SERIES: PRIME™ PLANETARY GEARHEAD [RATIOS FROM 3:1 TO 700:1]

HIGH PERFORMANCE  
HIGH ACCELERATION

4-7

#### PM SERIES: PRIMETRIC™ PLANETARY GEARHEAD [RATIOS FROM 3:1 TO 700:1]

HIGH PERFORMANCE/ACCELERATION  
HIGH RADIAL LOADING

8-11

#### PN SERIES: PARAGON™ PLANETARY GEARHEAD [RATIOS FROM 3:1 TO 100:1]

MODERATE PERFORMANCE  
MODERATE ACCELERATION

12-15

#### RADIAL & AXIAL LOAD SPECIFICATIONS [PM SERIES, PL SERIES AND PN SERIES]

16-17

#### SI SERIES: SPUR INLINE GEARHEADS [RATIOS FROM 3:1 TO 100:1]

MODERATE PERFORMANCE  
LIGHT TO MODERATE ACCELERATION

18-19

### RIGHT ANGLE GEARHEADS

#### RC/DC SERIES: PRIME™ RIGHT ANGLE PLANETARY GEARHEAD [RATIOS FROM 3:1 TO 700:1]

HIGH PERFORMANCE  
HIGH ACCELERATION

20-23

#### RN/DN SERIES: PARAGON™ RIGHT ANGLE PLANETARY GEARHEAD [RATIOS FROM 3:1 TO 100:1]

MODERATE PERFORMANCE  
MODERATE ACCELERATION

24-27

#### RS/DS SERIES: SPUR RIGHT ANGLE GEARHEAD [RATIOS FROM 3:1 TO 100:1]

MODERATE PERFORMANCE  
LIGHT TO MODERATE ACCELERATION

28-29

### OFFSET GEARMOTORS

#### SP SERIES: SPUR OFFSET GEARMOTORS [INCLUDES THE STEP MOTOR]

LIGHT DUTY PERFORMANCE

30-31

### CUSTOM PRODUCTS-SPECIAL FEATURES

#### CUSTOM PRODUCTS COMPONENT PARTS & CUSTOM GEARHEADS

32-33

34-35

### PRODUCT SELECTION GUIDE

#### MOTOR MANUFACTURERS AND 48 HOUR SHIPPING GEARHEAD ORDERING INFORMATION

36

37

#### PRODUCT SELECTION GUIDE

38-39

#### APPLICATION FLOWCHART

40-41

#### APPLICATION FORM

42

#### ISO 9001:2000 CERTIFICATE

43

#### WARRANTY INFORMATION

44

#### PRECISION FEATURES

45



## CGI'S PLANETARY GEARHEAD SYSTEM

True planetary gearing is provided by three or more planet gears revolving around a single pinion, or sun gear, which allows internal "load sharing" over the planet gears. When compared to spur gearheads where only two gears mesh simultaneously, a true planetary design can offer three to five times more torque capacity and greater performance. With CGI's studies of various applications, we have determined our true planetary design to be optimum for moderate to high torque factors. These factors include radial and axial loading, weight, lubrication, operating temperature extremes, typical torque/speed load points, etc.

## NEMA MOUNTING INTERFACES

Presently there are no interface mounting standards for Brushless DC and servo motor products. Users of motion control equipment may have difficulty trying to mount a motor to a bulkhead and other peripheral equipment, such as gearheads. One motor manufacturer's dimensions may not have the same mounting dimensions as other motor manufacturers.

Step motors experienced a mounting interface standardization in 1972, which was the direct effort of industry leaders in the Incremental Motion Control Society (IMCS) and the National Electrical Manufacturers Association (NEMA). There is an industry trend by these same agencies to establish a set of standard dimensions for all motors. This standard governs the package size (square dimension or diameter if round) commonly called frame size (established sizes are 17, 23, 34, and 42). This also governs mounting hole diameter and bolt circle, pilot diameter, pilot length, shaft diameter and shaft length. Although step motors conform to "NEMA" standards, there is a need for a larger shaft diameter for the more powerful BLDC and servo motors, since the present step motor diameters are not able to transfer the torque ratings that these more powerful motors generate.

The entire CGI standard planetary gearhead family, excluding the PriMetric™, has the same mounting dimensions as "NEMA" motors, with the exception being larger shaft diameters. Due to higher torque levels generated by the gearhead, the larger diameter shafts are required.

## GEARHEAD DURABILITY FACTORS

There are many factors that affect the life of a gearhead which fall into four (4) categories: Gear Geometry, Surface Durability, Lubrication, and Service Factors.

CGI adheres to AGMA (American Gear Manufacturers Association) standards in the design and analysis of **gear geometry**. CGI takes into consideration diametral pitch, number of teeth, face width, load distribution, material strength, heat treatment, RPM and hours of life. If any of these factors are not appropriate for the application, it may result in a shortening of the gearhead life. Proper gear geometry ensures smooth transmission of power. By optimizing gear geometry, we can reduce excess heat and noise generated at the gear mesh. CGI has years of experience in application engineering to assist them in determining the correct gearhead design and proper material selections for critical applications

**Surface durability** is the gear tooth's surface resistance to wear. This wear is the greatest when the RPM is high and the torque being transmitted through the gear is high. Gears must be hardened if they are expected to have a long life. All CGI gear components are specially heat treated to prevent excessive gear tooth surface wear.

**Lubrication** is very critical for the long life of any gearhead. Lubrications fail for two reasons. First, operating in an ambient temperature that is higher than the grease is rated for and second is time. CGI gearheads can endure wide operating temperature extremes without damage. Our standard synthetic grease has an operating temperature range of -40° C to +150° C (-40° F to +300° F). Our front and rear mounting brackets are manufactured from aluminum, which is an excellent heat sink that conducts heat away from the gears and allows for longer lubrication life. CGI has additional lubrications for specialized applications, such as greases and dry film lubricants rated for space use and high vacuum applications that need to conform to very low "out-gassing" requirements.

**Service Factors** apply to the torque ratings a gearhead is capable of withstanding based on direction, motion, profile, RPM, shock loads, number of cycles per hour and/or how many hours per day it is in operation. To determine the correct service factor when evaluating torque ratings for your application, please look under our **Product Selection Guide/Application Sheet (page 40-42)**.

**CGI wants to provide you with the best gearhead solution to match your needs. Here are some factors to consider to maximize your application system's performance:**

- Motor Type
- Torque
- Speed/RPM
- Inertia Match
- Radial/Axial Loading
- System Resolution
- Life Expectancy
- Noise
- System Stiffness

## AGMA GEAR QUALITY

AGMA stands for the American Gear Manufacturer's Association. This agency has established specific tolerances that are associated with an AGMA Quality Class or Level (per AGMA 2000-A 88). Commercial gears typically are classed between AGMA 5 to AGMA 9. Precision gears range between AGMA 10 to AGMA 14. In comparison master gears are AGMA 15. CGI gears range between AGMA 10 and 13, depending on application.

## SINGLE PIECE CONSTRUCTION

CGI uses precision gear cutting machines to obtain high AGMA levels, ensuring the highest quality gears are used in our motion control products. To reduce the effects of tolerance stack-ups during the assembly process of our gearhead products, we make all ring gears, output shaft/carrier plates from a single piece of high strength steel. This process gives our customers a much quieter and stronger gearhead compared to many of the gearheads on the market with two piece construction.

## GEARHEAD OUTPUT BEARING SYSTEMS

Our Inline Planetary and Spur gearhead output shafts are soundly supported by a precision radial sealed ball bearing system. Our choice of sealed ball bearings prolongs the life of both the gearhead and bearings by 1) providing a separation between the bearing system lubrication and the gearhead lubrication and 2) retaining and protecting the lubrication systems from both leaks and contaminants.

Our Right Angle Planetary and Spur gearhead output shafts are rigidly supported by a dual, preloaded, tapered roller bearing system capable of very high axial and radial loads. The tapered bearings are also sealed to provide a contamination barrier and retain both gearhead and bearing lubrication.

Our PriMetric™ Planetary, Prime™ Planetary, Paragon™ Planetary and Spur gearhead bearings, when used within the stated maximum performance conditions, will perform throughout the warranted life of the gearhead. (See our catalog bearing data charts for load value on pages 16 and 17.)

## CAGED ROLLER BEARINGS

We install high quality caged roller bearings inside our case hardened planet gears for long life, even when subjected to heavy torque loads.

## CLAMP-ON PINION GEARS / QUICK INSTALLATION

CGI uses a balanced two-piece clamp and pinion gear design that is easy and quick to install on motor shafts. We make these pinion gears out of high strength steel and finish by heat treating for a long life. Our gearheads come complete with detailed instructions, all mounting hardware, and Allen wrenches. Complete gearhead to motor installation takes only minutes.

## VITON O-RINGS

O-Rings seal each joint of our Prime™, PriMetric™ and Spur Inline gearhead families to prevent outside contamination from entering the gearhead. The Viton material is chemically resistant and can withstand temperatures over 400° F (204° C).

NOTE: For complete sealing of motor to the gearhead, apply Loctite™ 515 (liquid gasket), or equivalent, to the motor's face where it contacts the rear surface of the gearhead.

**CGI's Sales and Engineering Staff will gladly assist you with these or any other application/technical issues you may have.**

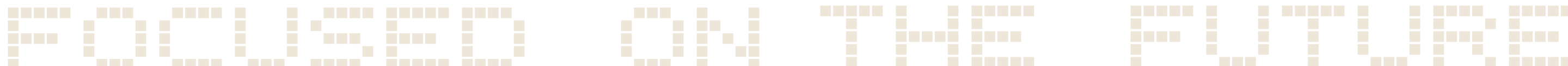

# PL SERIES: PRIME™ PLANETARY GEARHEADS

SINGLE, DOUBLE, TRIPLE STAGE  
PRECISION HIGH PERFORMANCE GEARHEADS

## CONSTRUCTION FEATURES

- True planetary design
- Low backlash design
- Input pinion with balanced clamp collar
- Quick installation
- Strong, caged roller bearings
- High reliability design
- High strength steels
- High shaft loading capacity
- Viton O-Ring sealed at each joint
- Sealed ball bearings
- High efficiency design
- All gears are heat treated
- NEMA mounting standards
- 5 year warranty



# PL SERIES: PRIME™ PLANETARY GEARHEADS

SINGLE, DOUBLE, TRIPLE STAGE  
PRECISION HIGH PERFORMANCE GEARHEADS

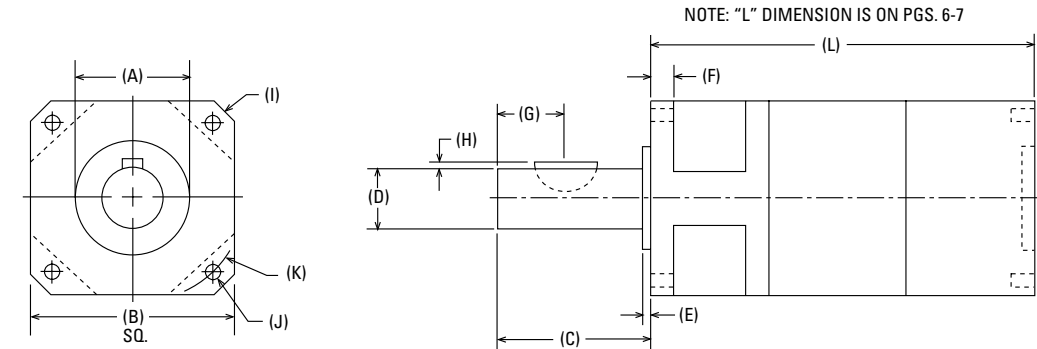

PART NUMBER	A PILOT DIAMETER (in.)	B SQUARE FLANGE (in.)	C SHAFT LENGTH (in.)	D SHAFT DIAMETER (in.)	E PILOT LENGTH (in.)	F FLANGE THICKNESS (in.)	G KEY LOCATION (in.)
017PLX	.864/.866	1.65	1.25	.4995/.5000	0.062	0.187	0.56
023PLX	1.498/1.500	2.25	1.25	.4995/.5000	0.062	0.250	0.56
034PLX	2.873/2.875	3.25	1.50	.7495/.7500	0.062	0.312	0.56
042PLX	2.185/2.187	4.20	2.00	.9995/1.0000	0.062	0.500	0.63
056PLX	4.498/4.500	5.75	2.50	1.4995/1.5000	0.125	0.750	0.94
075PLX	5.998/6.000	7.48	3.50	1.9995/2.0000	0.187	0.875	3.00 Lg

PART NUMBER	H KEY HEIGHT (in.)	I HOUSING DIAMETER (in.)	J BOLT HOLE DIAMETER (in.)	K BOLT HOLE CIRCLE (in.)	KEY WIDTH/ WOODRUFF KEY (in.)	RADIAL & AXIAL SHAFT LOADING (LBS.)
017PLX	0.054	2.05	0.125	1.725	0.125 / #404	SEE PAGE 17
023PLX	0.054	2.95	0.205	2.625	0.125 / #404	
034PLX	0.082	4.38	0.220	3.875	0.187 / #606	
042PLX	0.109	5.51	0.280	4.950	0.250 / #808	
056PLX	0.163	7.87	0.410	7.000	0.375 / #1212	
075PLX	0.157	9.64	0.560	8.465	3/8" x 5/8" RECT.	

AVAILABLE RATIOS	EFFICIENCY	SPECIFICATIONS
SINGLE STAGE : 3:1 / 4:1 / 5:1 / 5.5:1 / 7:1 / 10:1	90%	Input RPM: 6500 Max.
DOUBLE STAGE: 15:1/16:1/20:1/22:1/25:1/28:1/30:1/40:1/49:1/50:1/55:1/70:1/100:1	85%	Operating Temperature Range -40°F to +255°F
TRIPLE STAGE: 160:1 / 280:1 / 400:1 / 550:1 / 700:1 OTHER RATIOS AVAILABLE	80%	Motor Mounting Hardware Supplied

48 Hour Shipping

## PRIME™ IN TIME... 48 HOUR SHIPPING.

ALL SPECIFICATIONS SUBJECT TO CHANGE.





# PM SERIES: PRIMETRIC™ PLANETARY GEARHEADS

SINGLE, DOUBLE, TRIPLE STAGE  
PRECISION HIGH PERFORMANCE GEARHEADS

## CONSTRUCTION FEATURES

- Metric and standard NEMA motor mounting available
- High radial and axial shaft loading capacity
- True planetary design
- Low start-up torque
- High torque capability
- Compact design
- Popular metric output shaft and front bracket design
- Rigid stepped output shaft design with metric key and threaded mounting hole
- Ratios and sizes available for most applications
- 5 year warranty



# PM SERIES: PRIMETRIC™ PLANETARY GEARHEADS

SINGLE, DOUBLE, TRIPLE STAGE  
PRECISION HIGH PERFORMANCE GEARHEADS

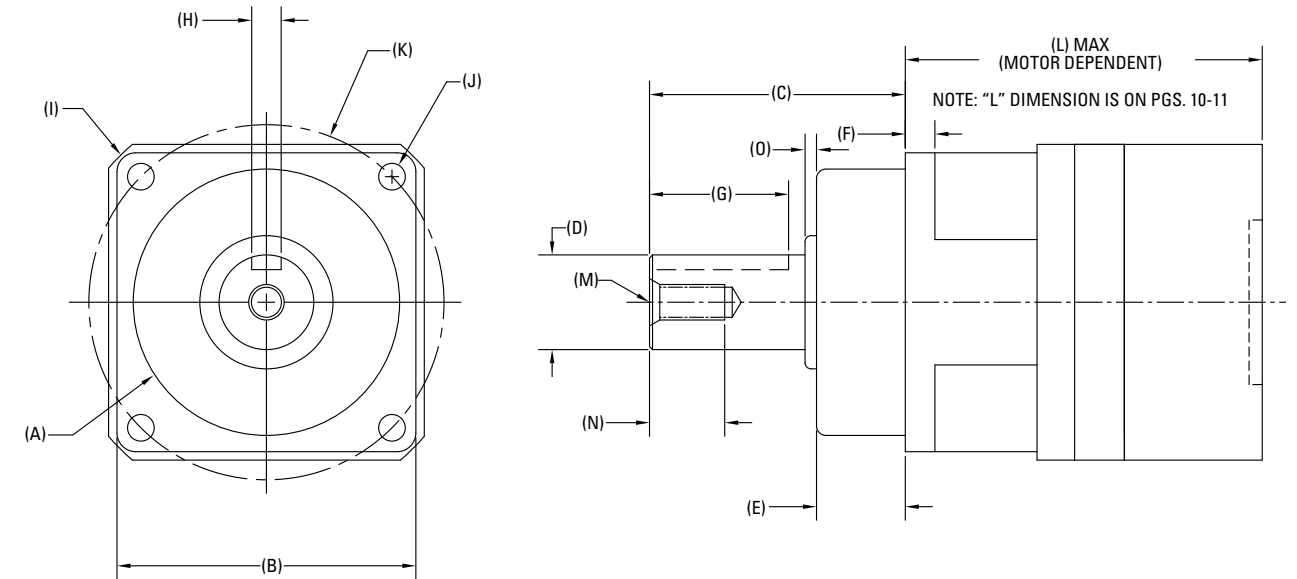

PART NUMBER	A PILOT DIAMETER mm (in.)	B SQUARE FLANGE mm (in.)	C SHAFT LENGTH mm (in.)	D SHAFT DIAMETER mm (in.)	E PILOT LENGTH mm (in.)	F FLANGE THICKNESS mm (in.)	G KEY LENGTH mm (in.)
040PMX	40.0 (1.575)	42.0 (1.654)	30.0 (1.181)	13.00 (.5118)	12.0 (.472)	5.0 (.197)	16.0 (.62)
060PMX	60.0 (2.362)	62.0 (2.441)	47.0 (1.850)	16.00 (.6299)	20.0 (.787)	6.0 (.236)	20.0 (.79)
075PMX	70.0 (2.756)	76.0 (2.992)	56.0 (2.205)	22.00 (.8661)	20.0 (.787)	7.0 (.276)	30.0 (1.18)
100PMX	90.0 (3.543)	101.0 (3.976)	86.5 (3.406)	32.00 (1.2598)	30.0 (1.181)	10.0 (.394)	47.0 (1.85)
140PMX	130.0 (5.118)	141.0 (5.551)	112.0 (4.409)	40.00 (1.5748)	30.0 (1.181)	19.0 (.748)	47.0 (1.85)
180PMX	160.0 (6.299)	182.0 (7.165)	112.0 (4.409)	55.00 (2.1654)	30.0 (1.181)	22.2 (.874)	60.0 (2.36)

PART NUMBER	H KEY WIDTH mm (in.)	I HOUSING DIAMETER mm (in.)	J BOLT HOLE DIAMETER mm (in.)	K BOLT HOLE CIRCLE mm (in.)	M THREAD	N THREAD DEPTH mm (in.)	O STEP
040PMX	5.0 (.197)	52.0 (2.047)	4.5 (.177)	46.0 (1.811)	M4 x 0.7	12.0 (.472)	1.5 (.060)
060PMX	5.0 (.197)	85.0 (3.346)	5.5 (.217)	68.0 (2.677)	M5 x 0.8	12.7 (.500)	2.0 (.079)
075PMX	8.0 (.315)	111.0 (4.370)	6.6 (.260)	85.0 (3.346)	M8 x 1.25	16.0 (.630)	2.0 (.079)
100PMX	10.0 (.394)	140.0 (5.512)	9.0 (.354)	120.0 (4.724)	M12 x 1.75	25.4 (1.000)	3.9 (.153)
140PMX	12.0 (.472)	200.0 (7.874)	11.0 (.433)	165.0 (6.496)	M16 x 1.5	32.0 (1.260)	5.0 (.197)
180PMX	16.0 (.630)	245.0 (9.646)	13.0 (.512)	215.0 (8.465)	M20 x 1.5	42.0 (1.654)	6.0 (.236)

Radial and Axial Shaft Loading (LBS) See page 16

AVAILABLE RATIOS	EFFICIENCY	SPECIFICATIONS
SINGLE STAGE: 3:1 / 4:1 / 5:1 / 5.5:1 / 7:1 / 10:1	90%	Input RPM: 6500 Max.
DOUBLE STAGE: 15:1/16:1/20:1/22:1/25:1/28:1/30:1/40:1/49:1/50:1/55:1/70:1/100:1	85%	Operating Temperature Range -40°F to +255°F
TRIPLE STAGE: 160:1 / 280:1 / 400:1 / 550:1 / 700:1 OTHER RATIOS AVAILABLE	80%	Motor Mounting Hardware Supplied

For complete product offerings,  
visit [www.cgimotion.com](http://www.cgimotion.com)



ALL SPECIFICATIONS SUBJECT TO CHANGE.



# PN SERIES: PARAGON™ PLANETARY GEARHEADS

## SINGLE AND DOUBLE STAGE PRECISION GEARHEADS

### CONSTRUCTION FEATURES

- True planetary design
- Low backlash design
- Input pinion with balanced clamp collar
- Quick installation
- Strong, caged roller bearings
- Sealed ball bearings
- High efficiency design
- All gears are heat treated
- NEMA mounting standards
- 2 year warranty



# PN SERIES: PARAGON™ PLANETARY GEARHEADS

## SINGLE AND DOUBLE STAGE PRECISION GEARHEADS

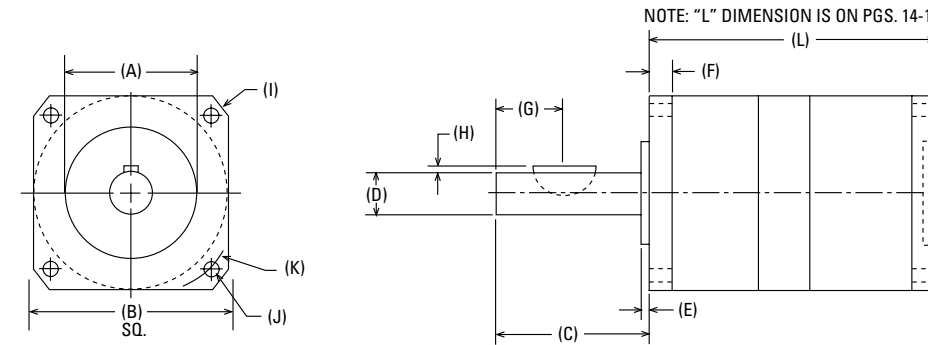

PART NUMBER	A PILOT DIAMETER (in.)	B SQUARE FLANGE (in.)	C SHAFT LENGTH (in.)	D SHAFT DIAMETER (in.)	E PILOT LENGTH (in.)	F FLANGE THICKNESS (in.)	G KEY LOCATION (in.)
017PNX	.864/.866	1.65	1.25	.4995/.5000	0.062	0.187	0.56
023PNX	1.498/1.500	2.25	1.25	.4995/.5000	0.062	0.250	0.56
034PNX	2.873/2.875	3.25	1.50	.7495/.7500	0.062	0.375	0.56
042PNX	2.185/2.187	4.20	2.00	.9995/1.0000	0.062	0.500	0.63
056PNX	4.498/4.500	5.75	2.50	1.4995/1.5000	0.125	0.750	0.94
075PNX	5.998/6.000	7.48	3.50	1.9995/2.0000	0.187	0.875	3.00 Lg

PART NUMBER	H KEY HEIGHT (in.)	I HOUSING DIAMETER (in.)	J BOLT HOLE DIAMETER (in.)	K BOLT HOLE CIRCLE (in.)	KEY WIDTH/WOODRUFF KEY (in.)	RADIAL & AXIAL SHAFT LOADING (LBS.)
017PNX	0.054	2.05	0.125	1.725	0.125 / #404	SEE PAGE 17
023PNX	0.054	2.95	0.205	2.625	0.125 / #404	
034PNX	0.082	4.38	0.220	3.875	0.187 / #606	
042PNX	0.109	5.51	0.280	4.950	0.250 / #808	
056PNX	0.163	7.87	0.410	7.000	0.375 / #1212	
075PNX	0.157	9.64	0.560	8.465	3/8" x 5/8" RECT.	

AVAILABLE RATIOS	EFFICIENCY	SPECIFICATIONS
SINGLE STAGE : 3:1 / 4:1 / 5.5:1 / 7:1 / 10:1	90%	Input RPM: 5000 Max.
DOUBLE STAGE: 16:1 / 22:1 / 28:1 / 40:1 / 49:1 / 55:1 / 70:1 / 100:1	85%	Operating Temperature Range -40°F to +255°F Motor Mounting Hardware Supplied

## A CGI EXCLUSIVE...

Developed for CGI by  
**UTS**  
Software  
www.uts.com

Gear sizing software to help you get the right product for your project.

SIZE IT...GEAR SIZING MADE EASY!



Quality at Every Turn

**SIZE-IT**  
Product Configurator

ALL SPECIFICATIONS SUBJECT TO CHANGE.



# PN SERIES: PARAGON™ PLANETARY GEARHEADS

## SINGLE, DOUBLE STAGE

# PN SERIES: PARAGON™ PLANETARY GEARHEADS

## SINGLE, DOUBLE STAGE

ALL SPECIFICATIONS SUBJECT TO CHANGE.

MODEL	RATIO	TORQUE RATING		INERTIA		BACKLASH	GEARHEAD	L
		T <sub>c</sub> IN LBS.	T <sub>PEAK</sub> IN LBS.	INPUT PINION OZ IN SEC <sup>2</sup>	GEARHEAD OZ IN SEC <sup>2</sup>	STD/ LOW ARC MINUTES	WEIGHT LBS.	GEARHEAD LENGTH
017PNX	3:1	125	174	2.163E-04	1.669E-04	10 / 7	1.0	2.66
017PNX	4:1	119	165	1.352E-04	1.053E-04	10 / 7	1.0	2.66
017PNX	5.5:1	107	149	1.174E-04	5.870E-05	10 / 7	1.0	2.66
017PNX	7:1	89	124	1.143E-04	3.692E-05	10 / 7	1.0	2.66
017PNX	10:1	56	84	1.132E-04	1.833E-05	10 / 7	1.0	2.66
017PNX	16:1	127	176	1.352E-04	1.045E-04	14 / 9	1.6	3.32
017PNX	22:1	128	178	1.174E-04	5.830E-05	14 / 9	1.6	3.32
017PNX	28:1	129	179	1.143E-04	3.667E-05	14 / 9	1.6	3.32
017PNX	40:1	131	181	1.132E-04	1.821E-05	14 / 9	1.6	3.32
017PNX	49:1	95	132	1.143E-04	3.479E-05	14 / 9	1.6	3.32
017PNX	55:1	117	162	1.132E-04	1.755E-05	14 / 9	1.6	3.32
017PNX	70:1	96	134	1.132E-04	1.729E-05	14 / 9	1.6	3.32
017PNX	100:1	52	77	1.132E-04	1.708E-05	14 / 9	1.6	3.32
023PNX	3:1	285	396	1.194E-03	4.866E-04	10 / 7	2.0	3.06
023PNX	4:1	264	366	9.502E-04	3.113E-04	10 / 7	2.0	3.06
023PNX	5.5:1	238	330	8.969E-04	1.746E-04	10 / 7	2.0	3.06
023PNX	7:1	197	274	8.880E-04	1.100E-04	10 / 7	2.0	3.06
023PNX	10:1	119	179	8.846E-04	5.471E-05	10 / 7	2.0	3.06
023PNX	16:1	282	391	9.502E-04	3.287E-04	14 / 9	3.0	3.97
023PNX	22:1	285	396	8.969E-04	1.838E-04	14 / 9	3.0	3.97
023PNX	28:1	288	400	8.880E-04	1.157E-04	14 / 9	3.0	3.97
023PNX	40:1	291	405	8.846E-04	5.749E-05	14 / 9	3.0	3.97
023PNX	49:1	213	295	8.880E-04	1.098E-04	14 / 9	3.0	3.97
023PNX	55:1	260	362	8.846E-04	5.543E-05	14 / 9	3.0	3.97
023PNX	70:1	215	298	8.846E-04	5.460E-05	14 / 9	3.0	3.97
023PNX	100:1	110	164	8.846E-04	5.393E-05	14 / 9	3.0	3.97
034PNX	3:1	964	1339	4.901E-03	4.672E-03	10 / 7	7.0	4.56
034PNX	4:1	914	1270	2.522E-03	2.833E-03	10 / 7	7.0	4.56
034PNX	5.5:1	835	1160	2.040E-03	1.585E-03	10 / 7	7.0	4.56
034PNX	7:1	701	934	1.955E-03	9.983E-04	10 / 7	7.0	4.56
034PNX	10:1	507	704	1.923E-03	4.961E-04	10 / 7	7.0	4.56
034PNX	16:1	986	1370	2.522E-03	2.824E-03	14 / 9	8.0	5.83
034PNX	22:1	1000	1389	2.040E-03	1.580E-03	14 / 9	8.0	5.83
034PNX	28:1	1009	1402	1.955E-03	9.952E-04	14 / 9	8.0	5.83
034PNX	40:1	1023	1421	1.923E-03	4.946E-04	14 / 9	8.0	5.83
034PNX	49:1	762	1058	1.955E-03	9.417E-04	14 / 9	8.0	5.83
034PNX	55:1	924	1283	1.923E-03	4.759E-04	14 / 9	8.0	5.83
034PNX	70:1	770	1070	1.923E-03	4.684E-04	14 / 9	8.0	5.83
034PNX	100:1	507	761	1.923E-03	4.623E-04	14 / 9	8.0	5.83

ALL SPECIFICATIONS SUBJECT TO CHANGE.

MODEL	RATIO	TORQUE RATING		INERTIA		BACKLASH	GEARHEAD	L
		T <sub>c</sub> IN LBS.	T <sub>PEAK</sub> IN LBS.	INPUT PINION OZ IN SEC <sup>2</sup>	GEARHEAD OZ IN SEC <sup>2</sup>	STD/ LOW ARC MINUTES	WEIGHT LBS.	GEARHEAD LENGTH
042PNX	3:1	1726	2398	1.680E-02	1.641E-02	10 / 7	12.0	5.20
042PNX	4:1	1646	2287	1.032E-02	1.049E-02	10 / 7	12.0	5.20
042PNX	5.5:1	1516	2106	8.997E-03	5.878E-03	10 / 7	12.0	5.20
042PNX	7:1	1283	178a2	8.766E-03	3.704E-03	10 / 7	12.0	5.20
042PNX	10:1	936	1300	8.680E-03	1.841E-03	10 / 7	12.0	5.20
042PNX	16:1	1784	2478	1.032E-02	1.101E-02	14 / 9	18.0	6.80
042PNX	22:1	1810	2515	8.997E-03	6.156E-03	14 / 9	18.0	6.80
042PNX	28:1	1829	2540	8.766E-03	3.875E-03	14 / 9	18.0	6.80
042PNX	40:1	1855	2577	8.680E-03	1.925E-03	14 / 9	18.0	6.80
042PNX	49:1	1400	1945	8.766E-03	3.706E-03	14 / 9	18.0	6.80
042PNX	55:1	1688	2344	8.680E-03	1.866E-03	14 / 9	18.0	6.80
042PNX	70:1	1417	1969	8.680E-03	1.843E-03	14 / 9	18.0	6.80
042PNX	100:1	1024	1423	8.680E-03	1.823E-03	14 / 9	18.0	6.80
056PNX	3:1	3877	5385	5.794E-02	7.141E-02	10 / 7	28.0	8.16
056PNX	4:1	3710	5153	3.123E-02	4.524E-02	10 / 7	28.0	8.16
056PNX	5.5:1	3425	4758	2.564E-02	2.527E-02	10 / 7	28.0	8.16
056PNX	7:1	2916	4051	2.470E-02	1.590E-02	10 / 7	28.0	8.16
056PNX	10:1	2143	2977	2.435E-02	7.899E-03	10 / 7	28.0	8.16
056PNX	16:1	4047	5622	3.123E-02	4.702E-02	14 / 9	43.0	10.30
056PNX	22:1	4111	5711	2.564E-02	2.621E-02	14 / 9	43.0	10.30
056PNX	28:1	4157	5774	2.470E-02	1.648E-02	14 / 9	43.0	10.30
056PNX	40:1	4220	5862	2.435E-02	8.184E-03	14 / 9	43.0	10.30
056PNX	49:1	3204	4451	2.470E-02	1.576E-02	14 / 9	43.0	10.30
056PNX	55:1	3845	5341	2.435E-02	7.932E-03	14 / 9	43.0	10.30
056PNX	70:1	3246	4509	2.435E-02	7.830E-03	14 / 9	43.0	10.30
056PNX	100:1	2361	3279	2.435E-02	7.746E-03	14 / 9	43.0	10.30
075PNX	3:1	10005	36975	1.936E-01	2.930E-01	10 / 7	66.0	10.41
075PNX	4:1	9535	13245	6.554E-02	1.889E-01	10 / 7	66.0	10.41
075PNX	5.5:1	9574	13300	4.015E-02	1.062E-01	10 / 7	66.0	10.41
075PNX	7:1	8107	11261	3.574E-02	6.702E-02	10 / 7	66.0	10.41
075PNX	10:1	5959	8277	3.410E-02	3.335E-02	10 / 7	66.0	10.41
075PNX	16:1	11474	15938	6.554E-02	1.928E-01	14 / 9	105.0	13.29
075PNX	22:1	11671	161212	4.015E-02	1.083E-01	14 / 9	105.0	13.29
075PNX	28:1	11810	16405	3.574E-02	6.831E-02	14 / 9	105.0	13.29
075PNX	40:1	12005	16676	3.410E-02	3.398E-02	14 / 9	105.0	13.29
075PNX	49:1	8976	12469	3.574E-02	6.523E-02	14 / 9	105.0	13.29
075PNX	55:1	10848	15069	3.410E-02	3.291E-02	14 / 9	105.0	13.29
075PNX	70:1	9100	12641	3.410E-02	3.247E-02	14 / 9	105.0	13.29
075PNX	100:1	6447	9184	3.410E-02	3.212E-02	14 / 9	105.0	13.29

**NOTES:** Other ratios are also available, consult factory.  
T<sub>c</sub>: Output torque is rated at 3000 RPM, and a minimum life of 10,000 hours.  
Bearing load ratings are based on a minimum life of 10,000 hours.

## PRIMETRIC

These graphs display the allowable radial load (lbs.) at a given distance (in.) from the mount face based on an  $L_{10}$  life of 10,000 hours.

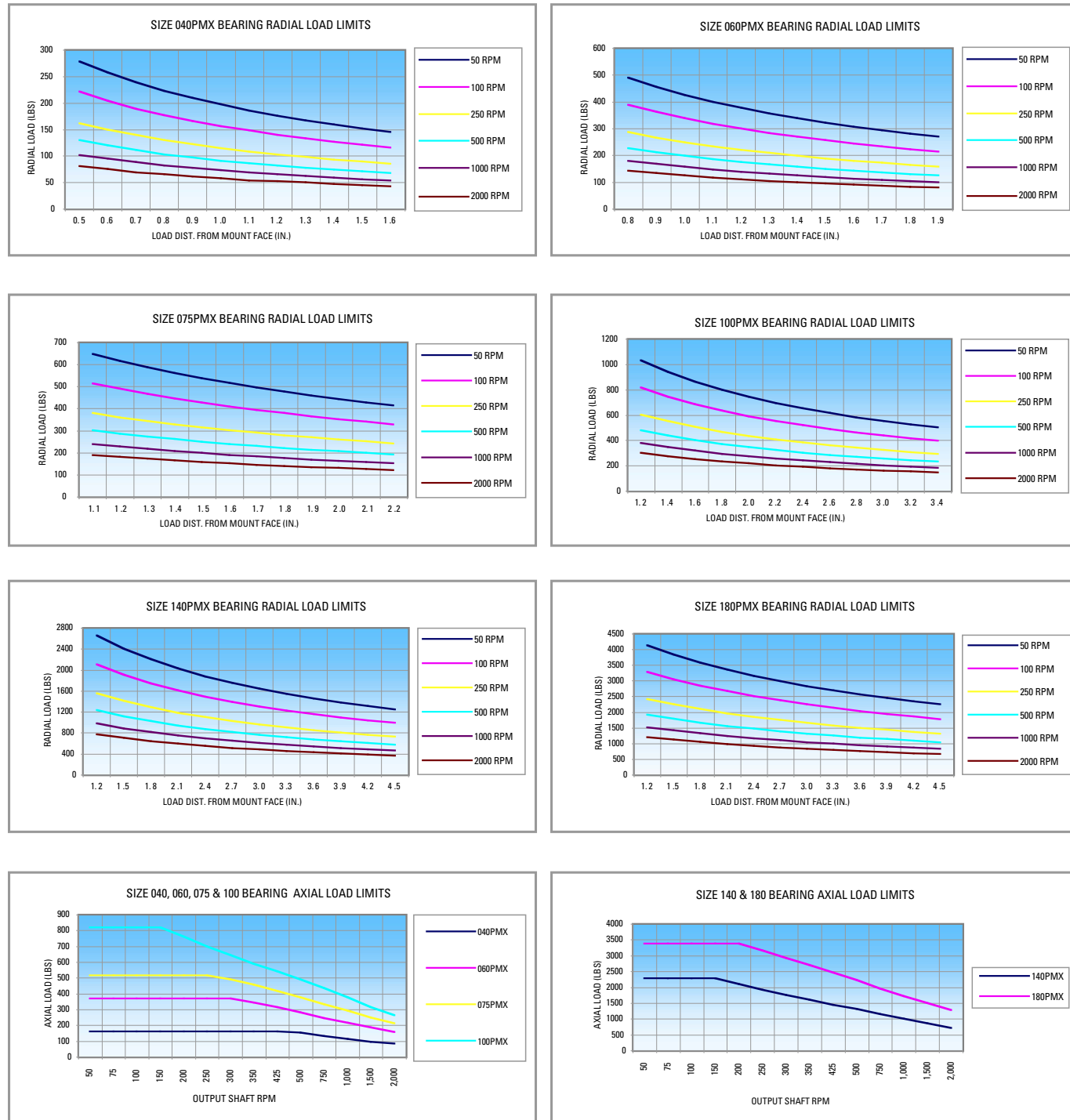

## PRIME & PARAGON

These graphs display the allowable radial load (lbs.) at a given distance (in.) from the mount face based on an  $L_{10}$  life of 10,000 hours.

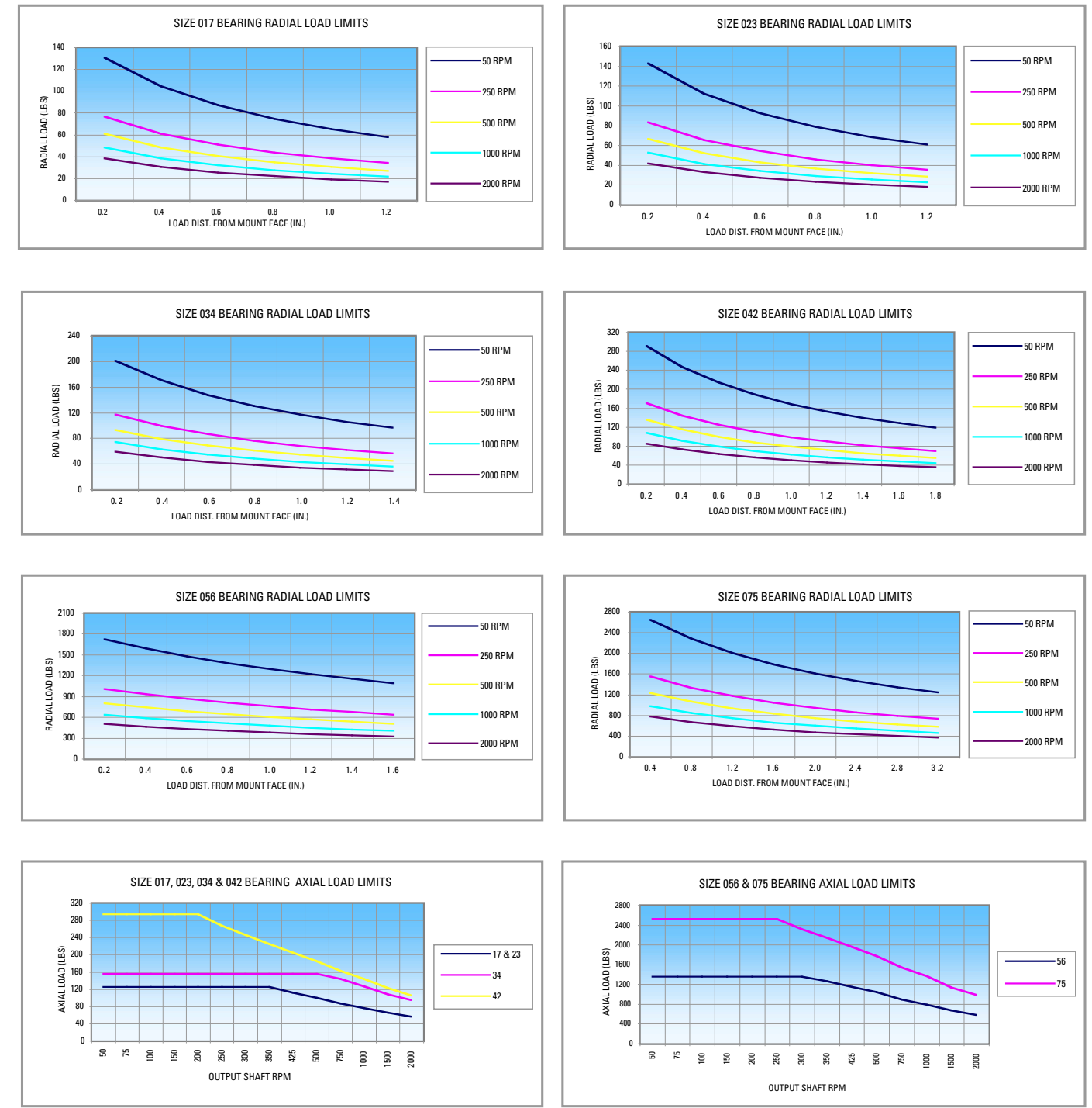

# SI SERIES: SPUR GEARHEADS

## NEMA DIMENSIONS PRECISION GEARHEADS

### CONSTRUCTION FEATURES

- One-piece gear cluster
- High-quality spur gearhead
- Input pinion with balanced clamp collar
- Quick installation
- High reliability design
- High strength steels
- High shaft loading capacity
- Viton O-Rings sealed at each joint
- Sealed ball bearings
- High efficiency design
- All gears are heat treated
- NEMA mounting standards
- 2 year warranty



# SI SERIES: SPUR GEARHEADS

## NEMA DIMENSIONS PRECISION GEARHEADS

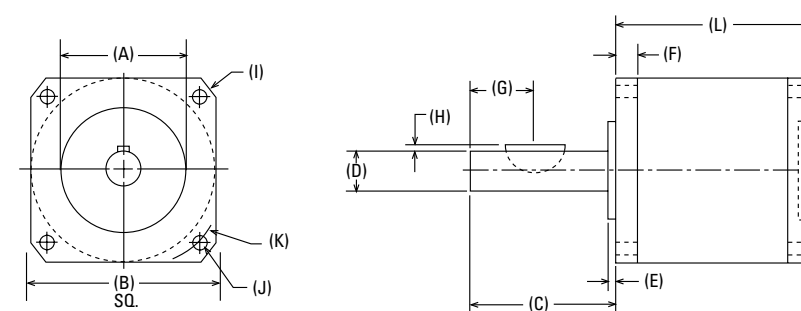

PART NUMBER	A PILOT DIAMETER (in.)	B SQUARE FLANGE (in.)	C SHAFT LENGTH (in.)	D SHAFT DIAMETER (in.)	E PILOT LENGTH (in.)	F FLANGE THICKNESS (in.)	G KEY LOCATION (in.)
023SIX	1.498/1.500	2.25	1.00	.3745/.3750	0.062	0.188	0.38
034SIX	2.873/2.875	3.25	1.25	.4995/.5000	0.062	0.375	0.56
042SIX	2.185/2.187	4.20	1.50	.6245/.6250	0.062	0.500	0.50
056SIX	4.498/4.500	5.75	2.00	.9995/1.0000	0.125	1.000	0.63
PART NUMBER	H KEY HEIGHT (in.)	I HOUSING DIAMETER (in.)	J BOLT HOLE DIAMETER (in.)	K BOLT HOLE CIRCLE (in.)	KEY WIDTH/ WOODRUFF KEY (in.)	RADIAL SHAFT LOADING (LBS.)	AXIAL SHAFT LOADING (LBS.)
023SIX	.041	2.95	0.205	2.625	0.094 / #303	75	75
034SIX	.054	4.38	0.220	3.875	0.125 / #404	100	125
042SIX	.068	5.51	0.280	4.950	0.156 / #505	150	150
056SIX	.109	7.87	0.410	7.000	0.250 / #808	200	300
PART NUMBER	L GEARHEAD LENGTH (in.)	BACKLASH STD/LOW (ARC-MINUTES)	CONTINUOUS TORQUE MAX. (IN LBS.)	MOMENTARY TORQUE MAX. (IN LBS.)	GEARHEAD WEIGHT (LBS.)	MAX. INERTIA REFLECTED TO INPUT (OZ. IN. SEC <sup>2</sup> )	PINION GEAR INERTIA (OZ. IN. SEC <sup>2</sup> )
023SIX	2.25	20/10	20	30	1.5	7.15E-04	7.59E-04
034SIX	3.00	20/10	60	90	3.5	5.35E-04	1.52E-03
042SIX	3.75	20/10	200	300	6.5	4.33E-03	7.59E-03
056SIX	4.50	20/10	350	500	15.5	6.05E-03	4.57E-02

AVAILABLE RATIOS AND SHAFT ROTATION*					SPECIFICATIONS		
SIZE 023	3:1	SAME	SIZE 034	3:1	Input RPM: 4000 Max.		
	5:1	SAME		5:1		Minimum Efficiency: 90%	
	10:1	SAME		10:1			
	15:1	OPPOSITE		15:1			Operating Temperature Range -40°F to +255°F
	20:1	OPPOSITE		20:1			
	30:1	OPPOSITE		30:1			
50:1	OPPOSITE	50:1	Note: Size 056 Requires a Mounting Adapter				
100:1	SAME	100:1					
SIZE 042	3:1	SAME		SIZE 056	3:1	Motor Mounting Hardware Supplied	
	5:1	SAME			5:1		
	10:1	SAME			10:1		
	15:1	OPPOSITE			15:1		
	20:1	OPPOSITE	25:1				
	30:1	SAME	40:1				
50:1	OPPOSITE						
100:1	SAME						

\*Rotation references the gearhead output shaft direction with respect to motor shaft direction.

ALL SPECIFICATIONS SUBJECT TO CHANGE.



# RC/DC SERIES: PRIME™ PLANETARY RIGHT ANGLE GEARHEADS

SINGLE, DOUBLE, TRIPLE STAGE-SINGLE OR DOUBLE SHAFT  
PRECISION HIGH PERFORMANCE GEARHEADS

## CONSTRUCTION FEATURES

- True planetary design
- Tapered roller bearings
- Low backlash design
- Input pinion with balanced clamp collar
- Quick installation
- Strong, caged roller bearings
- High reliability design
- High strength steels
- High shaft loading capacity
- Viton O-Rings sealed at each joint
- Case hardened spiral bevel gears
- Sealed ball bearings
- High efficiency design
- All gears are heat treated
- NEMA mounting standards
- 5 year warranty

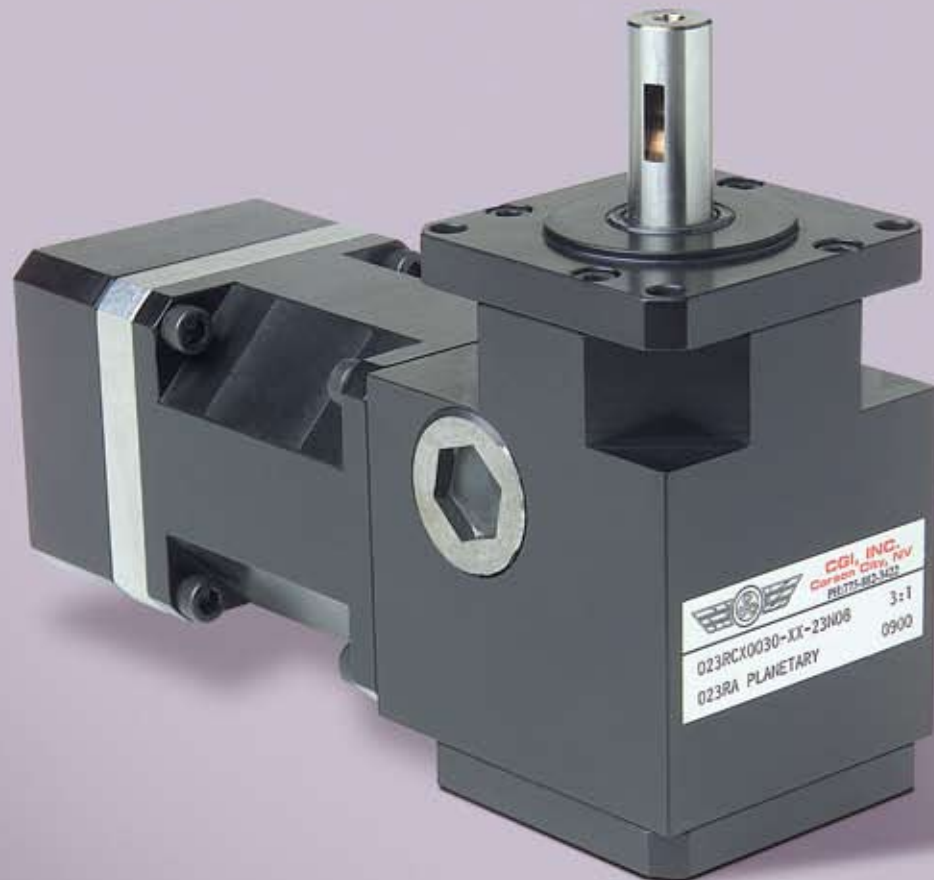

# RC/DC SERIES: PRIME™ PLANETARY RIGHT ANGLE GEARHEADS

SINGLE, DOUBLE, TRIPLE STAGE-SINGLE OR DOUBLE SHAFT  
PRECISION HIGH PERFORMANCE GEARHEADS

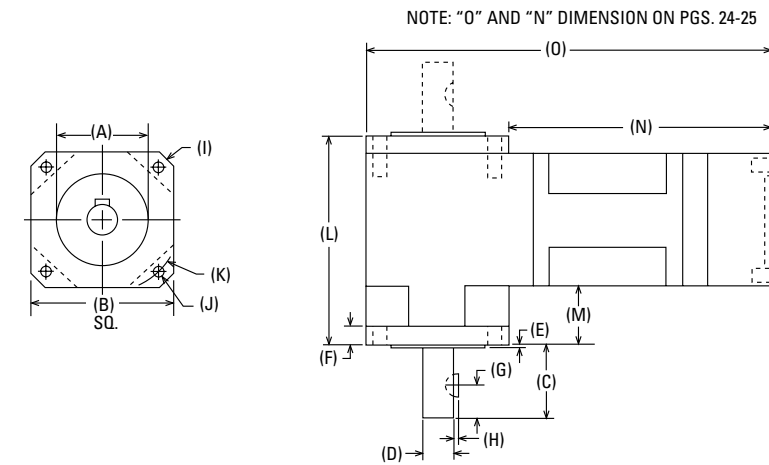

PART NUMBER	A PILOT DIAMETER (in.)	B SQUARE FLANGE (in.)	C SHAFT LENGTH (in.)	D SHAFT DIAMETER (in.)	E PILOT LENGTH (in.)	F FLANGE THICKNESS (in.)	G KEY LOCATION (in.)	H KEY HEIGHT (in.)
017RCX/017DCX	.864/.866	1.65	1.25	.3745/.3750	0.062	0.250	0.38	0.041
023RCX/023DCX	1.498/1.500	2.25	1.25	.4995/.5000	0.062	0.312	0.56	0.054
034RCX/034DCX	2.873/2.875	3.25	1.50	.7495/.7500	0.062	0.500	0.56	0.082
042RCX/042DCX	2.185/2.187	4.20	2.00	.9995/1.0000	0.062	0.500	0.63	0.109
056RCX/056DCX	4.498/4.500	5.75	2.50	1.4995/1.5000	0.093	0.750	0.94	0.163
075RCX/075DCX	5.998/6.000	7.48	3.50	1.9995/2.0000	0.187	0.875	3.00 Lg	0.157
PART NUMBER	I HOUSING DIAMETER (in.)	J BOLT HOLE DIAMETER (in.)	K BOLT HOLE CIRCLE (in.)	L RIGHT ANGLE WIDTH (in.)	M OVERHANG WIDTH (in.)	KEY WIDTH/ WOODRUFF KEY (in.)	RADIAL SHAFT LOADING (LBS.)	AXIAL SHAFT LOADING (LBS.)
017RCX/017DCX	2.05	0.125	1.725	2.72	0.82	0.094 / #303	400	400
023RCX/023DCX	2.95	0.205	2.625	3.55	0.99	0.125 / #404	600	600
034RCX/034DCX	4.38	0.220	3.875	5.14	1.38	0.187 / #606	900	900
042RCX/042DCX	5.51	0.280	4.950	5.89	1.18	0.250 / #808	1400	1400
056RCX/056DCX	7.87	0.410	7.000	8.79	2.28	0.375 / #1212	2200	2200
075RCX/075DCX	9.64	0.560	8.465	11.30	2.95	3/8" x 5/8" RECT.	3200	3200

AVAILABLE RATIOS	EFFICIENCY	SPECIFICATIONS
SINGLE STAGE : 3:1 / 4:1 / 5:1 / 5.5:1 / 7:1 / 10:1	85%	Input RPM: 6500 Max.
DOUBLE STAGE: 15:1/16:1/20:1/22:1/25:1/28:1/30:1/40:1/49:1/50:1/55:1/70:1/100:1	80%	Operating Temperature Range -40°F to +255°F
TRIPLE STAGE: 160:1 / 280:1 / 400:1 / 550:1 / 700:1 OTHER RATIOS AVAILABLE	75%	Motor Mounting Hardware Supplied

PRECISION,  
INSIDE AND OUT.



ALL SPECIFICATIONS SUBJECT TO CHANGE.

# RC/DC SERIES: PRIME™ PLANETARY RIGHT ANGLE GEARHEADS

## SINGLE, DOUBLE, TRIPLE STAGE-SINGLE OR DOUBLE SHAFT

MODEL	RATIO	TORQUE RATING		INERTIA		BACKLASH	GEARHEAD	N	O
		T <sub>c</sub> IN LBS.	T <sub>PEAK</sub> IN LBS.	INPUT PINION OZ IN SEC <sup>2</sup>	GEARHEAD OZ IN SEC <sup>2</sup>	STD/ LOW ARC MINUTES	WEIGHT LBS.	LENGTH TO FLANGE	GEARHEAD LENGTH
017RCX	3:1	167	261	2.163E-04	4.153E-04	11 / 8	2.8	3.30	4.97
017RCX	4:1	158	248	1.352E-04	2.478E-04	11 / 8	2.8	3.30	4.97
017RCX	5:1	148	231	1.203E-04	1.720E-04	11 / 8	2.8	3.30	4.97
017RCX	5.5:1	143	223	1.174E-04	1.341E-04	11 / 8	2.8	3.30	4.97
017RCX	7:1	119	158	1.143E-04	8.344E-05	11 / 8	2.8	3.30	4.97
017RCX	10:1	56	84	1.132E-04	4.113E-05	11 / 8	2.8	3.30	4.97
017RCX	15:1	178	277	1.203E-04	1.142E-04	15 / 10	3.4	3.84	5.51
017RCX	16:1	169	264	1.352E-04	1.088E-04	15 / 10	3.4	3.84	5.51
017RCX	20:1	170	266	1.203E-04	7.664E-05	15 / 10	3.4	3.84	5.51
017RCX	22:1	171	267	1.174E-04	6.056E-05	15 / 10	3.4	3.84	5.51
017RCX	25:1	159	247	1.203E-04	4.931E-05	15 / 10	3.4	3.84	5.51
017RCX	28:1	172	269	1.143E-04	3.806E-05	15 / 10	3.4	3.84	5.51
017RCX	30:1	183	285	1.132E-04	3.487E-05	15 / 10	3.4	3.84	5.51
017RCX	40:1	174	272	1.132E-04	1.889E-05	15 / 10	3.4	3.84	5.51
017RCX	49:1	127	199	1.143E-04	3.525E-05	15 / 10	3.4	3.84	5.51
017RCX	50:1	161	251	1.132E-04	3.236E-05	15 / 10	3.4	3.84	5.51
017RCX	55:1	156	243	1.132E-04	1.791E-05	15 / 10	3.4	3.84	5.51
017RCX	70:1	128	201	1.132E-04	1.751E-05	15 / 10	3.4	3.84	5.51
017RCX	100:1	52	77	1.132E-04	1.719E-05	15 / 10	3.4	3.84	5.51
017RCX	160:1	181	283	1.132E-04	1.821E-05	19 / 12	4.0	4.46	6.11
017RCX	280:1	183	286	1.132E-04	1.735E-05	19 / 12	4.0	4.46	6.11
017RCX	400:1	185	286	1.132E-04	1.769E-05	19 / 12	4.0	4.46	6.11
017RCX	550:1	165	257	1.132E-04	1.767E-05	19 / 12	4.0	4.46	6.11
017RCX	700:1	136	212	1.132E-04	1.766E-05	19 / 12	4.0	4.46	6.11
023RCX	3:1	380	594	1.194E-03	1.539E-03	11 / 8	4.0	4.23	6.49
023RCX	4:1	360	562	9.502E-04	9.035E-04	11 / 8	4.0	4.23	6.49
023RCX	5:1	331	518	9.044E-04	6.264E-04	11 / 8	4.0	4.23	6.49
023RCX	5.5:1	317	496	8.969E-04	4.878E-04	11 / 8	4.0	4.23	6.49
023RCX	7:1	263	411	8.880E-04	3.034E-04	11 / 8	4.0	4.23	6.49
023RCX	10:1	119	179	8.846E-04	1.495E-04	11 / 8	4.0	4.23	6.49
023RCX	15:1	396	619	9.044E-04	3.634E-04	15 / 10	5.0	5.05	7.32
023RCX	16:1	376	587	9.502E-04	3.461E-04	15 / 10	5.0	5.05	7.32
023RCX	20:1	378	591	9.044E-04	2.440E-04	15 / 10	5.0	5.05	7.32
023RCX	22:1	380	594	8.969E-04	1.930E-04	15 / 10	5.0	5.05	7.32
023RCX	25:1	347	543	9.044E-04	1.572E-04	15 / 10	5.0	5.05	7.32
023RCX	28:1	384	600	8.880E-04	1.214E-04	15 / 10	5.0	5.05	7.32
023RCX	30:1	408	639	8.846E-04	1.112E-04	15 / 10	5.0	5.05	7.32
023RCX	40:1	388	607	8.846E-04	6.027E-05	15 / 10	5.0	5.05	7.32
023RCX	49:1	286	447	8.880E-04	1.117E-04	15 / 10	5.0	5.05	7.32
023RCX	50:1	361	564	8.846E-04	1.026E-04	15 / 10	5.0	5.05	7.32
023RCX	55:1	347	542	8.846E-04	5.690E-05	15 / 10	5.0	5.05	7.32
023RCX	70:1	288	450	8.846E-04	5.551E-05	15 / 10	5.0	5.05	7.32
023RCX	100:1	110	164	8.846E-04	5.438E-05	15 / 10	5.0	5.05	7.32
023RCX	160:1	404	631	8.846E-04	5.760E-05	19 / 12	6.0	5.85	8.10
023RCX	280:1	409	640	8.846E-04	5.461E-05	19 / 12	6.0	5.85	8.10
023RCX	400:1	406	608	8.846E-04	5.591E-05	19 / 12	6.0	5.85	8.10
023RCX	550:1	368	575	8.846E-04	5.584E-05	19 / 12	6.0	5.85	8.10
023RCX	700:1	303	473	8.846E-04	5.581E-05	19 / 12	6.0	5.85	8.10
034RCX	3:1	1285	2008	4.901E-03	1.176E-02	11 / 8	12.5	5.91	9.16
034RCX	4:1	1219	1905	2.522E-03	6.818E-03	11 / 8	12.5	5.91	9.16
034RCX	5:1	1148	1795	2.115E-03	4.735E-03	11 / 8	12.5	5.91	9.16
034RCX	5.5:1	1113	1740	2.040E-03	3.693E-03	11 / 8	12.5	5.91	9.16
034RCX	7:1	935	1461	1.955E-03	2.300E-03	11 / 8	12.5	5.91	9.16
034RCX	10:1	552	828	1.923E-03	1.134E-03	11 / 8	12.5	5.91	9.16
034RCX	15:1	1381	2158	2.115E-03	3.091E-03	15 / 10	13.5	7.04	10.29
034RCX	16:1	1315	2055	2.522E-03	2.944E-03	15 / 10	13.5	7.04	10.29
034RCX	20:1	1324	2069	2.115E-03	2.077E-03	15 / 10	13.5	7.04	10.29
034RCX	22:1	1333	2083	2.040E-03	1.644E-03	15 / 10	13.5	7.04	10.29
034RCX	25:1	1244	1945	2.115E-03	1.340E-03	15 / 10	13.5	7.04	10.29
034RCX	28:1	1346	2103	1.955E-03	1.035E-03	15 / 10	13.5	7.04	10.29
034RCX	30:1	1430	2235	1.923E-03	9.482E-04	15 / 10	13.5	7.04	10.29
034RCX	40:1	1364	2132	1.923E-03	5.139E-04	15 / 10	13.5	7.04	10.29
034RCX	49:1	1015	1587	1.955E-03	9.545E-04	15 / 10	13.5	7.04	10.29
034RCX	50:1	1267	1980	1.923E-03	8.764E-04	15 / 10	13.5	7.04	10.29
034RCX	55:1	1232	1925	1.923E-03	4.861E-04	15 / 10	13.5	7.04	10.29
034RCX	70:1	1027	1605	1.923E-03	4.747E-04	15 / 10	13.5	7.04	10.29
034RCX	100:1	507	761	1.923E-03	4.654E-04	15 / 10	13.5	7.04	10.29
034RCX	160:1	1424	2226	1.923E-03	4.930E-04	19 / 12	14.5	8.26	11.51
034RCX	280:1	1445	2258	1.923E-03	4.676E-04	19 / 12	14.5	8.26	11.51
034RCX	400:1	1458	2278	1.923E-03	4.781E-04	19 / 12	14.5	8.26	11.51
034RCX	550:1	1311	2048	1.923E-03	4.775E-04	19 / 12	14.5	8.26	11.51
034RCX	700:1	1090	1703	1.923E-03	4.772E-04	19 / 12	14.5	8.26	11.51

ALL SPECIFICATIONS SUBJECT TO CHANGE.

# RC/DC SERIES: PRIME™ PLANETARY RIGHT ANGLE GEARHEADS

## SINGLE, DOUBLE, TRIPLE STAGE-SINGLE OR DOUBLE SHAFT

MODEL	RATIO	TORQUE RATING		INERTIA		BACKLASH	GEARHEAD	N	O
		T <sub>c</sub> IN LBS.	T <sub>PEAK</sub> IN LBS.	INPUT PINION OZ IN SEC <sup>2</sup>	GEARHEAD OZ IN SEC <sup>2</sup>	STD/ LOW ARC MINUTES	WEIGHT LBS.	LENGTH TO FLANGE	GEARHEAD LENGTH
042RCX	3:1	2301	3597	1.680E-02	2.667E-02	11 / 8	28.5	7.18	11.39
042RCX	4:1	2195	3430	1.032E-02	1.626E-02	11 / 8	28.5	7.18	11.39
042RCX	5:1	2079	3249	9.201E-03	1.137E-02	11 / 8	28.5	7.18	11.39
042RCX	5.5:1	2021	3159	8.997E-03	8.931E-03	11 / 8	28.5	7.18	11.39
042RCX	7:1	1711	2673	8.766E-03	5.588E-03	11 / 8	28.5	7.18	11.39
042RCX	10:1	1122	1684	8.680E-03	2.765E-03	11 / 8	28.5	7.18	11.39
042RCX	15:1	2485	3884	9.201E-03	1.174E-02	15 / 10	35.0	8.81	13.02
042RCX	16:1	2379	3717	1.032E-02	1.118E-02	15 / 10	35.0	8.81	13.02
042RCX	20:1	2397	3745	9.201E-03	7.888E-03	15 / 10	35.0	8.81	13.02
042RCX	22:1	2414	3772	8.997E-03	6.242E-03	15 / 10	35.0	8.81	13.02
042RCX	25:1	2263	3536	9.201E-03	5.085E-03	15 / 10	35.0	8.81	13.02
042RCX	28:1	2438	3811	8.766E-03	3.928E-03	15 / 10	35.0	8.81	13.02
042RCX	30:1	2579	4032	8.680E-03	3.599E-03	15 / 10	35.0	8.81	13.02
042RCX	40:1	2473	3865	8.680E-03	1.951E-03	15 / 10	35.0	8.81	13.02
042RCX	49:1	1867	2918	8.766E-03	3.724E-03	15 / 10	35.0	8.81	13.02
042RCX	50:1	2308	3606	8.680E-03	3.417E-03	15 / 10	35.0	8.81	13.02
042RCX	55:1	2250	3516	8.680E-03	1.880E-03	15 / 10	35.0	8.81	13.02
042RCX	70:1	1890	2953	8.680E-03	1.851E-03	15 / 10	35.0	8.81	13.02
042RCX	100:1	1031	1547	8.680E-03	1.827E-03	15 / 10	35.0	8.81	13.02
042RCX	160:1	2587	4044	8.680E-03	1.934E-03	19 / 12	36.0	10.37	14.57
042RCX	280:1	2627	4105	8.680E-03	1.845E-03	19 / 12	36.0	10.37	14.57
042RCX	400:1	2651	4142	8.680E-03	1.884E-03	19 / 12	36.0	10.37	14.57
042RCX	550:1	2400	3750	8.680E-03	1.882E-03	19 / 12	36.0	10.37	14.57
042RCX	700:1	2009	3140	8.680E-03	1.881E-03	19 / 12	36.0	10.37	14.57
056RCX	3:1	5169	8078	5.794E-02	9.725E-02	11 / 8	56.0	10.13	15.86
056RCX	4:1	4946	7730	3.123E-02	5.977E-02	11 / 8	56.0	10.13	15.86
056RCX	5:1	4693	7335	2.647E-02	4.189E-02	11 / 8	56.0	10.13	15.86
056RCX	5.5:1	4567	7137	2.564E-02	3.295E-02	11 / 8	56.0	10.13	15.86
056RCX	7:1	3898	6076	2.470E-02	2.065E-02	11 / 8	56.0	10.13	15.86
056RCX	10:1	2767	4150	2.435E-02	1.022E-02	11 / 8	56.0	10.13	15.86
056RCX	15:1	5619	8781	2.647E-02	4.970E-02	15 / 10	71.0	12.27	18.03
056RCX	16:1	5396	8433	3.123E-02	4.733E-02	15 / 10	71.0	12.27	18.03
056RCX	20:1	5439	8500	2.647E-02	3.336E-02	15 / 10	71.0	12.27	18.03
056RCX	22:1	5482	8567	2.564E-02	2.637E-02	15 / 10	71.0	12.27	18.03
056RCX	25:1	5143	8038	2.647E-02	2.148E-02	15 / 10	71.0	12.27	18.03
056RCX	28:1	5542	8661	2.470E-02	1.658E-02	15 / 10	71.0	12.27	18.03
056RCX	30:1								

# RN/DN SERIES: PARAGON™ PLANETARY RIGHT ANGLE GEARHEADS

SINGLE, DOUBLE STAGE-SINGLE OR DOUBLE SHAFT  
PRECISION GEARHEADS

## CONSTRUCTION FEATURES

- True planetary design
- Tapered roller bearings
- Low backlash design
- Input pinion with balanced clamp collar
- Quick installation
- Strong, caged roller bearings
- High reliability design
- High strength steels
- High shaft loading capacity
- Case hardened spiral bevel gears
- Sealed ball bearings
- High efficiency design
- All gears are heat treated
- NEMA mounting standards
- 2 year warranty



# RN/DN SERIES: PARAGON™ PLANETARY RIGHT ANGLE GEARHEADS

SINGLE, DOUBLE STAGE-SINGLE OR DOUBLE SHAFT  
PRECISION GEARHEADS

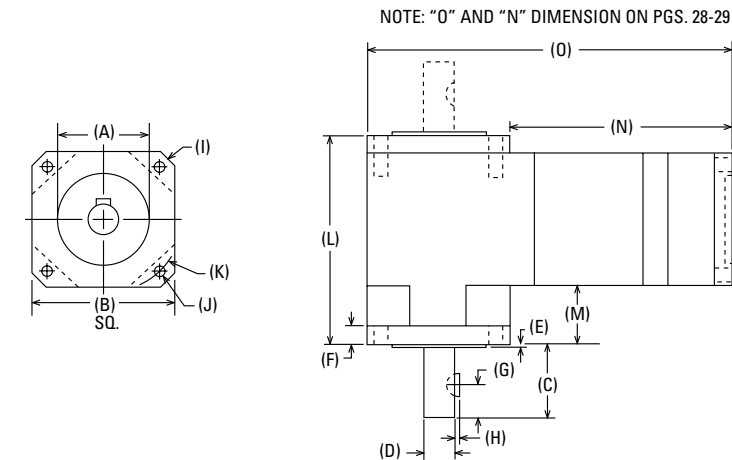

PART NUMBER	A PILOT DIAMETER (in.)	B SQUARE FLANGE (in.)	C SHAFT LENGTH (in.)	D SHAFT DIAMETER (in.)	E PILOT LENGTH (in.)	F FLANGE THICKNESS (in.)	G KEY LOCATION (in.)	H KEY HEIGHT (in.)
017RNX/017DNX	864/.866	1.65	1.25	.3745/.3750	0.062	0.250	0.38	0.041
023RNX/023DNX	1.498/1.500	2.25	1.25	.4995/.5000	0.062	0.312	0.56	0.054
034RNX/034DNX	2.873/2.875	3.25	1.50	.7495/.7500	0.062	0.500	0.56	0.082
042RNX/042DNX	2.185/2.187	4.20	2.00	.9995/1.0000	0.062	0.500	0.63	0.109
056RNX/056DNX	4.498/4.500	5.75	2.50	1.4995/1.5000	0.093	0.750	0.94	0.163
075RNX/075DNX	5.998/6.000	7.48	3.50	1.9995/2.0000	0.187	0.875	3.00 Lg	0.157
PART NUMBER	I HOUSING DIAMETER (in.)	J BOLT HOLE DIAMETER (in.)	K BOLT HOLE CIRCLE (in.)	L RIGHT ANGLE WIDTH (in.)	M OVERHANG WIDTH (in.)	KEY WIDTH/ WOODRUFF KEY (in.)	RADIAL SHAFT LOADING (LBS.)	AXIAL SHAFT LOADING (LBS.)
017RNX/017DNX	2.05	0.125	1.725	2.72	0.82	0.094 / #303	400	400
023RNX/023DNX	2.95	0.205	2.625	3.55	0.99	0.125 / #404	600	600
034RNX/034DNX	4.38	0.220	3.875	5.14	1.38	0.187 / #606	900	900
042RNX/042DNX	5.51	0.280	4.950	5.89	1.18	0.250 / #808	1400	1400
056RNX/056DNX	7.87	0.410	7.000	8.79	2.28	0.375 / #1212	2200	2200
075RNX/075DNX	9.64	0.560	8.465	11.30	2.95	3/8"x 5/8" RECT.	3200	3200

AVAILABLE RATIOS	EFFICIENCY	SPECIFICATIONS
SINGLE STAGE : 3:1 / 4:1 / 5.5:1 / 7:1 / 10:1	85%	Input RPM: 5000 Max.
DOUBLE STAGE: 16:1 / 22:1 / 28:1 / 40:1 / 49:1 / 55:1 / 70:1 / 100:1	80%	Operating Temperature Range -40°F to +255°F Motor Mounting Hardware Supplied



**PRODUCTS WITH VISION.  
FOR ENGINEERS...BY ENGINEERS.**

The fountains at the Bellagio Casino in Las Vegas, Nevada are powered by CGI, INC. precision gearheads.

ALL SPECIFICATIONS SUBJECT TO CHANGE.



# RN/DN SERIES: PARAGON™ PLANETARY RIGHT ANGLE GEARHEADS

## SINGLE, DOUBLE STAGE-SINGLE OR DOUBLE SHAFT

# RN/DN SERIES: PARAGON™ PLANETARY RIGHT ANGLE GEARHEADS

## SINGLE, DOUBLE STAGE-SINGLE OR DOUBLE SHAFT

ALL SPECIFICATIONS SUBJECT TO CHANGE.

MODEL	RATIO	TORQUE RATING		INERTIA		BACKLASH	GEARHEAD	N	O
		T <sub>c</sub> IN LBS.	T <sub>PEAK</sub> IN LBS.	INPUT PINION OZ IN SEC <sup>2</sup>	GEARHEAD OZ IN SEC <sup>2</sup>	STD/ LOW ARC MINUTES	WEIGHT LBS.	LENGTH TO FLANGE	GEARHEAD LENGTH
017RNX	3:1	125	174	2.163E-04	1.669E-04	14 / 11	2.8	3.30	4.97
017RNX	4:1	119	165	1.352E-04	1.053E-04	14 / 11	2.8	3.30	4.97
017RNX	5.5:1	107	149	1.174E-04	5.870E-05	14 / 11	2.8	3.30	4.97
017RNX	7:1	89	124	1.143E-04	3.692E-05	14 / 11	2.8	3.30	4.97
017RNX	10:1	56	84	1.132E-04	1.833E-05	14 / 11	2.8	3.30	4.97
017RNX	16:1	127	176	1.352E-04	1.045E-04	18 / 13	3.4	3.97	5.62
017RNX	22:1	128	178	1.174E-04	5.830E-05	18 / 13	3.4	3.97	5.62
017RNX	28:1	129	179	1.143E-04	3.667E-05	18 / 13	3.4	3.97	5.62
017RNX	40:1	131	181	1.132E-04	1.821E-05	18 / 13	3.4	3.97	5.62
017RNX	49:1	95	132	1.143E-04	3.479E-05	18 / 13	3.4	3.97	5.62
017RNX	55:1	117	162	1.132E-04	1.755E-05	18 / 13	3.4	3.97	5.62
017RNX	70:1	96	134	1.132E-04	1.729E-05	18 / 13	3.4	3.97	5.62
017RNX	100:1	52	77	1.132E-04	1.708E-05	18 / 13	3.4	3.97	5.62
023RNX	3:1	285	396	1.194E-03	4.866E-04	14 / 11	4.2	4.51	6.78
023RNX	4:1	264	366	9.502E-04	3.113E-04	14 / 11	4.2	4.51	6.78
023RNX	5.5:1	238	330	8.969E-04	1.746E-04	14 / 11	4.2	4.51	6.78
023RNX	7:1	197	274	8.880E-04	1.100E-04	14 / 11	4.2	4.51	6.78
023RNX	10:1	119	179	8.846E-04	5.471E-05	14 / 11	4.2	4.51	6.78
023RNX	16:1	282	391	9.502E-04	3.287E-04	18 / 13	5.2	5.41	7.68
023RNX	22:1	285	396	8.969E-04	1.838E-04	18 / 13	5.2	5.41	7.68
023RNX	28:1	288	400	8.880E-04	1.157E-04	18 / 13	5.2	5.41	7.68
023RNX	40:1	291	405	8.846E-04	5.749E-05	18 / 13	5.2	5.41	7.68
023RNX	49:1	213	295	8.880E-04	1.098E-04	18 / 13	5.2	5.41	7.68
023RNX	55:1	260	362	8.846E-04	5.543E-05	18 / 13	5.2	5.41	7.68
023RNX	70:1	215	298	8.846E-04	5.460E-05	18 / 13	5.2	5.41	7.68
023RNX	100:1	110	164	8.846E-04	5.393E-05	18 / 13	5.2	5.41	7.68
034RNX	3:1	964	1339	4.901E-03	4.672E-03	14 / 11	12.4	6.27	9.53
034RNX	4:1	914	1270	2.522E-03	2.833E-03	14 / 11	12.4	6.27	9.53
034RNX	5.5:1	835	1160	2.040E-03	1.585E-03	14 / 11	12.4	6.27	9.53
034RNX	7:1	701	934	1.955E-03	9.983E-04	14 / 11	12.4	6.27	9.53
034RNX	10:1	507	704	1.923E-03	4.961E-04	14 / 11	12.4	6.27	9.53
034RNX	16:1	986	1370	2.522E-03	2.824E-03	18 / 13	13.4	7.54	10.80
034RNX	22:1	1000	1389	2.040E-03	1.580E-03	18 / 13	13.4	7.54	10.80
034RNX	28:1	1009	1402	1.955E-03	9.952E-04	18 / 13	13.4	7.54	10.80
034RNX	40:1	1023	1421	1.923E-03	4.946E-04	18 / 13	13.4	7.54	10.80
034RNX	49:1	762	1058	1.955E-03	9.417E-04	18 / 13	13.4	7.54	10.80
034RNX	55:1	924	1283	1.923E-03	4.759E-04	18 / 13	13.4	7.54	10.80
034RNX	70:1	770	1070	1.923E-03	4.684E-04	18 / 13	13.4	7.54	10.80
034RNX	100:1	507	761	1.923E-03	4.623E-04	18 / 13	13.4	7.54	10.80

ALL SPECIFICATIONS SUBJECT TO CHANGE.

MODEL	RATIO	TORQUE RATING		INERTIA		BACKLASH	GEARHEAD	N	O
		T <sub>c</sub> IN LBS.	T <sub>PEAK</sub> IN LBS.	INPUT PINION OZ IN SEC <sup>2</sup>	GEARHEAD OZ IN SEC <sup>2</sup>	STD/ LOW ARC MINUTES	WEIGHT LBS.	LENGTH TO FLANGE	GEARHEAD LENGTH
042RNX	3:1	1726	2398	1.680E-02	1.641E-02	14 / 11	29.0	7.64	11.85
042RNX	4:1	1646	2287	1.032E-02	1.049E-02	14 / 11	29.0	7.64	11.85
042RNX	5.5:1	1516	2106	8.997E-03	5.878E-03	14 / 11	29.0	7.64	11.85
042RNX	7:1	1283	1782	8.766E-03	3.704E-03	14 / 11	29.0	7.64	11.85
042RNX	10:1	936	1300	8.680E-03	1.841E-03	14 / 11	29.0	7.64	11.85
042RNX	16:1	1784	2478	1.032E-02	1.101E-02	18 / 13	35.0	9.24	13.45
042RNX	22:1	1810	2515	8.997E-03	6.156E-03	18 / 13	35.0	9.24	13.45
042RNX	28:1	1829	2540	8.766E-03	3.875E-03	18 / 13	35.0	9.24	13.45
042RNX	40:1	1855	2577	8.680E-03	1.925E-03	18 / 13	35.0	9.24	13.45
042RNX	49:1	1400	1945	8.766E-03	3.706E-03	18 / 13	35.0	9.24	13.45
042RNX	55:1	1688	2344	8.680E-03	1.866E-03	18 / 13	35.0	9.24	13.45
042RNX	70:1	1417	1969	8.680E-03	1.843E-03	18 / 13	35.0	9.24	13.45
042RNX	100:1	1024	1423	8.680E-03	1.823E-03	18 / 13	35.0	9.24	13.45
056RNX	3:1	3877	5385	5.794E-02	7.141E-02	14 / 11	56.0	10.90	16.66
056RNX	4:1	3710	5153	3.123E-02	4.524E-02	14 / 11	56.0	10.90	16.66
056RNX	5.5:1	3425	4758	2.564E-02	2.527E-02	14 / 11	56.0	10.90	16.66
056RNX	7:1	2916	4051	2.470E-02	1.590E-02	14 / 11	56.0	10.90	16.66
056RNX	10:1	2143	2977	2.435E-02	7.899E-03	14 / 11	56.0	10.90	16.66
056RNX	16:1	4047	5622	3.123E-02	4.702E-02	18 / 13	71.0	13.03	18.79
056RNX	22:1	4111	5711	2.564E-02	2.621E-02	18 / 13	71.0	13.03	18.79
056RNX	28:1	4157	5774	2.470E-02	1.648E-02	18 / 13	71.0	13.03	18.79
056RNX	40:1	4220	5862	2.435E-02	8.184E-03	18 / 13	71.0	13.03	18.79
056RNX	49:1	3204	4451	2.470E-02	1.576E-02	18 / 13	71.0	13.03	18.79
056RNX	55:1	3845	5341	2.435E-02	7.932E-03	18 / 13	71.0	13.03	18.79
056RNX	70:1	3246	4509	2.435E-02	7.830E-03	18 / 13	71.0	13.03	18.79
056RNX	100:1	2361	3279	2.435E-02	7.746E-03	18 / 13	71.0	13.03	18.79
075RNX	3:1	10005	36975	1.936E-01	2.930E-01	14 / 11	132.0	14.71	22.21
075RNX	4:1	9535	33245	6.554E-02	1.889E-01	14 / 11	132.0	14.71	22.21
075RNX	5.5:1	9574	33300	4.015E-02	1.062E-01	14 / 11	132.0	14.71	22.21
075RNX	7:1	8107	11261	3.574E-02	6.702E-02	14 / 11	132.0	14.71	22.21
075RNX	10:1	5959	8277	3.410E-02	3.335E-02	14 / 11	132.0	14.71	22.21
075RNX	16:1	11474	15938	6.554E-02	1.928E-01	18 / 13	210.0	17.61	25.09
075RNX	22:1	11671	161212	4.015E-02	1.083E-01	18 / 13	210.0	17.61	25.09
075RNX	28:1	11810	16405	3.574E-02	6.831E-02	18 / 13	210.0	17.61	25.09
075RNX	40:1	12005	16676	3.410E-02	3.398E-02	18 / 13	210.0	17.61	25.09
075RNX	49:1	8976	12469	3.574E-02	6.523E-02	18 / 13	210.0	17.61	25.09
075RNX	55:1	10848	15069	3.410E-02	3.291E-02	18 / 13	210.0	17.61	25.09
075RNX	70:1	9100	12641	3.410E-02	3.247E-02	18 / 13	210.0	17.61	25.09
075RNX	100:1	6447	9184	3.410E-02	3.212E-02	18 / 13	210.0	17.61	25.09

**NOTES:** Other ratios are also available, consult factory.  
T<sub>c</sub>: Output torque is rated at 3000 RPM, and a minimum life of 10,000 hours.  
Bearing load ratings are based on a minimum life of 10,000 hours.  
Torque specifications for the RNX and DNX are the same.

# RS/DS SERIES: SPUR RIGHT ANGLE GEARHEADS

## NEMA DIMENSIONS-SINGLE OR DOUBLE SHAFT PRECISION GEARHEADS

### CONSTRUCTION FEATURES

- One-piece gear cluster
- Tapered roller bearings
- High quality spur gearhead
- Input pinion with balanced clamp collar
- Quick installation
- High reliability design
- High strength steels
- High shaft loading capacity
- Viton O-Ring sealed at each joint
- Sealed ball bearings
- High efficiency design
- All gears are heat treated
- NEMA mounting standards
- 2 year warranty



# RS/DS SERIES: SPUR RIGHT ANGLE GEARHEADS

## NEMA DIMENSIONS-SINGLE OR DOUBLE SHAFT PRECISION GEARHEADS

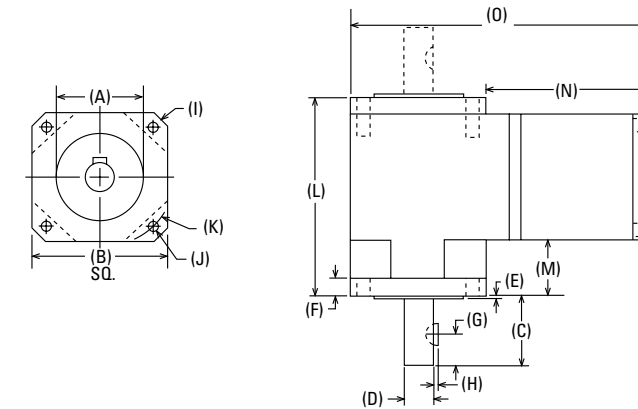

PART NUMBER	A PILOT DIAMETER (in.)	B SQUARE FLANGE (in.)	C SHAFT LENGTH (in.)	D SHAFT DIAMETER (in.)	E PILOT LENGTH (in.)	F FLANGE THICKNESS (in.)	G KEY LOCATION (in.)	H KEY HEIGHT (in.)
023RSX/023DSX	1.498/1.500	2.25	1.25	.4995/.5000	0.062	0.312	0.56	0.054
034RSX/034DSX	2.873/2.875	3.25	1.50	.7495/.7500	0.062	0.312	0.56	0.082
042RSX/042DSX	2.185/2.187	4.20	2.00	.9995/1.0000	0.062	0.500	0.63	0.109
056RSX/056DSX	4.498/4.500	5.75	2.50	1.4995/1.5000	0.093	0.750	0.94	0.163
PART NUMBER	I HOUSING DIAMETER (in.)	J BOLT HOLE DIAMETER (in.)	K BOLT HOLE CIRCLE (in.)	L RIGHT ANGLE WIDTH (in.)	M OVERHANG WIDTH (in.)	KEY WIDTH/ WOODRUFF KEY (in.)	RADIAL SHAFT LOADING (LBS.)	AXIAL SHAFT LOADING (LBS.)
023RSX/023DSX	2.95	0.205	2.625	3.55	0.99	0.125 / #404	300	300
034RSX/034DSX	4.38	0.220	3.875	5.14	1.38	0.187 / #606	500	500
042RSX/042DSX	5.51	0.280	4.950	5.89	1.18	0.250 / #808	700	700
056RSX/056DSX	7.87	0.410	7.000	8.79	2.28	0.375 / #1212	900	900
PART NUMBER	N LENGTH TO FLANGE (in.)	O GEARHEAD LENGTH (in.)	BACKLASH STD/LOW (ARC-MINUTES)	CONTINUOUS TORQUE MAX. (IN LBS.)	MOMENTARY TORQUE MAX. (IN LBS.)	GEARHEAD WEIGHT (LBS.)	MAX. INERTIA REFLECTED TO INPUT (OZ. IN. SEC <sup>2</sup> )	PINION GEAR INERTIA (OZ. IN. SEC <sup>2</sup> )
023RSX/023DSX	2.67	4.92	25/15	20	30	4.0	2.58 x 10 <sup>-5</sup>	7.59 x 10 <sup>-4</sup>
034RSX/034DSX	3.49	6.74	25/15	60	90	9.0	2.09 x 10 <sup>-4</sup>	1.52 x 10 <sup>-3</sup>
042RSX/042DSX	4.01	8.21	25/15	200	300	24.0	6.69 x 10 <sup>-4</sup>	7.59 x 10 <sup>-3</sup>
056RSX/056DSX	5.43	11.23	25/15	350	500	44.0	1.73 x 10 <sup>-3</sup>	4.57 x 10 <sup>-2</sup>

AVAILABLE RATIOS AND SHAFT ROTATION*						SPECIFICATIONS	
SIZE 023	3:1	SAME	SIZE 034	3:1	SAME	Input RPM: 4000 Max.	
	5:1	SAME		5:1	SAME	Minimum Efficiency: 90%	
	10:1	SAME		10:1	SAME	Operating Temperature Range -40°F to +255°F	
	15:1	OPPOSITE		15:1	SAME	Note: Size 056 Requires a Mounting Adapter	
	20:1	OPPOSITE		20:1	OPPOSITE	Motor Mounting Hardware Supplied	
	30:1	OPPOSITE		30:1	OPPOSITE		
	50:1	OPPOSITE		50:1	SAME		
	100:1	SAME		100:1	SAME		
SIZE 042	3:1	SAME	SIZE 056	3:1	SAME		
	5:1	SAME		5:1	SAME		
	10:1	SAME		10:1	OPPOSITE		
	15:1	OPPOSITE		15:1	OPPOSITE		
	20:1	OPPOSITE		25:1	OPPOSITE		
	30:1	SAME		40:1	SAME		
	50:1	OPPOSITE					
	100:1	SAME					

ALL SPECIFICATIONS SUBJECT TO CHANGE.

\*Rotation references the gearhead output shaft direction with respect to motor shaft direction.

# SP SERIES: LIGHT DUTY OFFSET GEARMOTORS

SIZES 017 AND 023-RATIOS 5, 10, 18:1

## CONSTRUCTION FEATURES

- One-piece gear cluster
- Cost-effective, light duty spur gearmotors
- Composite bushings throughout gearhead
- Gears are high strength steel and precision hobbled
- Output shaft is heat treated stainless steel
- High temperature, molded composite housing
- Supplied with a 17 or 23 frame step motor
- Standard industry dimensions
- 1 year warranty



# SP SERIES: LIGHT DUTY OFFSET GEARMOTORS

SIZES 017 AND 023-RATIOS 5, 10, 18:1

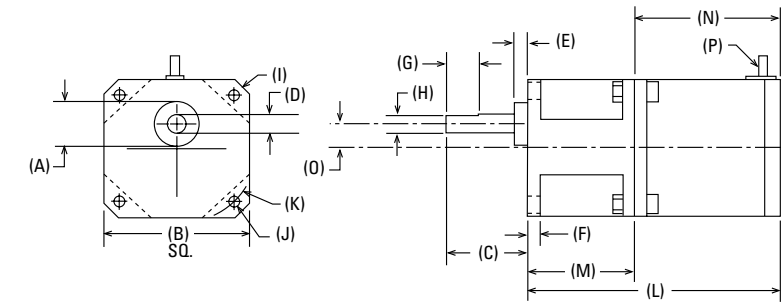

PART NUMBER	A PILOT DIAMETER (in.)	B SQUARE FLANGE (in.)	C SHAFT LENGTH (in.)	D SHAFT DIAMETER (in.)	E PILOT LENGTH (in.)	F FLANGE THICKNESS (in.)	O FLAT LENGTH (in.)	H DIMENSION OVER FLAT (in.)
017SPX 023SPX	.708 / .710	1.65 2.25	0.79 1.26	.2495 / .2500 .3120 / .3125	0.12 0.20	0.19 0.19	0.470 (2X) 0.500 (1X)	0.22 (2X) 0.29 (1X)
PART NUMBER	I HOUSING DIAMETER (in.)	J BOLT HOLE THREAD / DIAMETER	K BOLT HOLE CIRCLE (in.)	L GEARMOTOR LENGTH (in.)	M GEARHEAD LENGTH (in.)	N MOTOR LENGTH (in.)	O OFFSET DIMENSION (in.)	P NUMBER OF LEAD WIRES
017SPX 023SPX	2.05 3.05	M3 x .5 0.205 (in.)	1.725 2.625	2.86 4.7	0.98 1.67	1.88 3.03	0.31 0.39	8 6
PART NUMBER	RATED PHASE CURRENT (AMPS/PHASE)	NOMINAL MOTOR STEP ANGLE	BACKLASH (ARC-MINUTES)	RADIAL SHAFT PLAY (in.)	AXIAL SHAFT PLAY (in.)	GEARHEAD WEIGHT (OZ.)	PHASE RESISTANCE (OHMS +/-10%)	WINDING INDUCTANCE (mH +/-20%)
017SPX 023SPX	1.25 4.70	1.8" STEP 1.8" STEP	45 45	0.002 0.002	0.010 0.010	13 45	3.3@25°C .37@25°C	3.0 0.6
PART NUMBER	INPUT RPM (MAX.)	EFFICIENCY (MIN.) (AMPS/PHASE)	GEARHEAD MAX. CONT. TORQUE (OZ. in.)	SPECIFICATIONS				
017SPX 023SPX	1000 1000	80% 80%	160 320	Gearhead Ambient Operating Temperature Range -40°F to +255°F. Motor is rated to 265°F. Molded Composite Housing (Max. Temp. 420°F). Gears are High-Strength Heat-Treated Steel. Composite Bushings throughout Gearhead. Input/Output shafts turn in the same direction.				

**SIZE 017  
MOTOR P/N  
HT17-075P**

**SIZE 023  
MOTOR P/N  
4023-828P**

### Bipolar Chopper Drive Switching Sequence for CW Rotation Facing Mounting End

Step	A+	A-	B+	B-
0	+	-	+	-
1	-	+	+	-
2	-	+	-	+
3	+	-	-	+
4	+	-	+	-

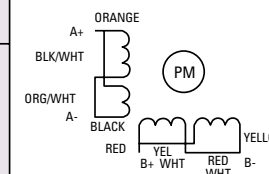

### Bipolar Chopper Drive Switching Sequence for CW Rotation Facing Mounting End

Step	Red	Black	Green	White
0	+	-	+	-
1	-	+	+	-
2	-	+	-	+
3	+	-	-	+
4	+	-	+	-

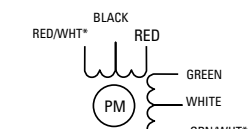

Motor Connection: Center Tap to end

\* These wires are not used; do not connect them or ground them. They must be electrically isolated.

ALL SPECIFICATIONS SUBJECT TO CHANGE.



# For custom gearhead requirements...

## CORE COMPETENCE AT CGI MEANS...CUSTOMS.

CGI has been building to custom gear requirements for over 36 years and we're still going strong. Time and time again customers continue to bring us application requirements that no other manufacturer can do quickly and inexpensively.

The following products on these two pages are only a few of the hundreds of custom gearheads we have built for a wide variety of industries including Fortune 500 companies in the semiconductor, food packaging, military and medical industries. So whether it's something simple as a special shaft or ratio or something more complex, CGI is the only choice. Contact our applications engineering department for more information.

## LINEAR SLIDE

CGI gearheads are easily adapted to any of the commercially available linear slide products on the market. All of our inline or right-angle gearheads can be used to help reduce inertia. Our products match up directly to products manufactured by: Intek, Linear Industries, Daedel, Star Linear, THK, NSK, IKO, Warner, Tol-O-Matic, Macron Dynamics and Industrial Devices.

## CUSTOM SHAFT OPTIONS

CGI gearheads offer increased design flexibility when built with custom shaft options such as dual-output shaft, hollow shaft and even custom input shafts that allows easy mounting to options like brakes, encoders or safety couplings that are used between the motor and the gearhead.

## AEROSPACE AND MEDICAL

CGI has built custom products for the Hubble Telescope project as well as custom components for surgical hand tools for the medical industry. More and more companies rely on CGI to build non-standard products that meet the stringent requirements of these two very important industries.

## SEMICONDUCTOR AND FOOD PACKAGING EQUIPMENT

CGI Prime™ PL Series gearheads can be manufactured with special seals and special grease for both the semiconductor and food packaging equipment industries. The gearheads meet various IP ratings and are usually painted white rather than our standard black anodized.

# ...CGI is your only choice.



FOR THE PAST 36 YEARS

WE'VE BEEN THE ONLY CHOICE



CGI, Inc. is renowned for being able to provide complex precision-machined component parts of high quality and hold tolerances as tight as 2.5 microns. These parts are machined from diverse metals, and involve a variety of hardness, surface treatment, heat-treating and plating requirements. Applications range from nuclear submarines, space vehicles, surgical devices, various semi-conductor manufacturing equipment, robotics and machine tool automation.





## CGI GEARHEADS MOUNT DIRECTLY TO MOTORS MANUFACTURED BY THE FOLLOWING:

### Partial Listing:

Aerotech  
Allen-Bradley  
Anaheim Automation  
Animatics  
Applied Motion Products  
Baldor  
Bodine  
CMC Torque Systems  
Compumotor  
Custom Servo Motors  
Dynetic Systems  
Eastern Air Devices  
Electro-Craft  
Emerson  
Empire Magnetics  
GE Fanuc  
Glentek  
Globe Motors  
Hathaway  
Hurst Manufacturing  
Indramat  
Industrial Devices  
Industrial Indexing  
Infranor  
Inland Motor  
Kollmorgen  
Lin Engineering  
Magmotor  
MCG  
MFM  
Mitsubishi  
Moog  
MyoStat  
Nyden  
Oriental Motor  
Ormec  
Pacific-Scientific  
Panasonic  
Parvex  
Pittman  
PMI  
QuickSilver  
Reliance  
Sanyo-Denki  
SEM  
Siemens  
Superior Electric  
Tamagawa  
Teknic  
Vickers  
Warner  
Yaskawa



Our 48 hour shipping program, raises the bar even higher. It ensures the shipment of select standard size and ratio gearheads in stock within 48 hours. By offering quick delivery, we are able to provide this advantage to customers needing a precise solution, and needing it quickly. The market demand for quick turnaround on standard size and ratio gearboxes has become overwhelming. Sales channels need to be able to react to customers' requests quickly. OEMs often face short development timeframes, especially in prototype applications while end-users, losing time and money in a break-down situation, need to get their replacement gearboxes in a hurry. We do our best to accommodate any rush situation.

### Featured Ratios and Sizes

48 Hour Shipping is available for popular sizes and ratios from our Prime, Primemetric, Paragon, Victory, Raptor, and Raptor EP Series product lines:

**017PLX**



**040PMX**



**023PLX**

**034PLX**

**017PNX**

**023PNX**

**034PNX**



**017VPX**

**023VPX**

**034VPX**



**060RTA**

**075RTA**



**023RTX**

**034RTX**

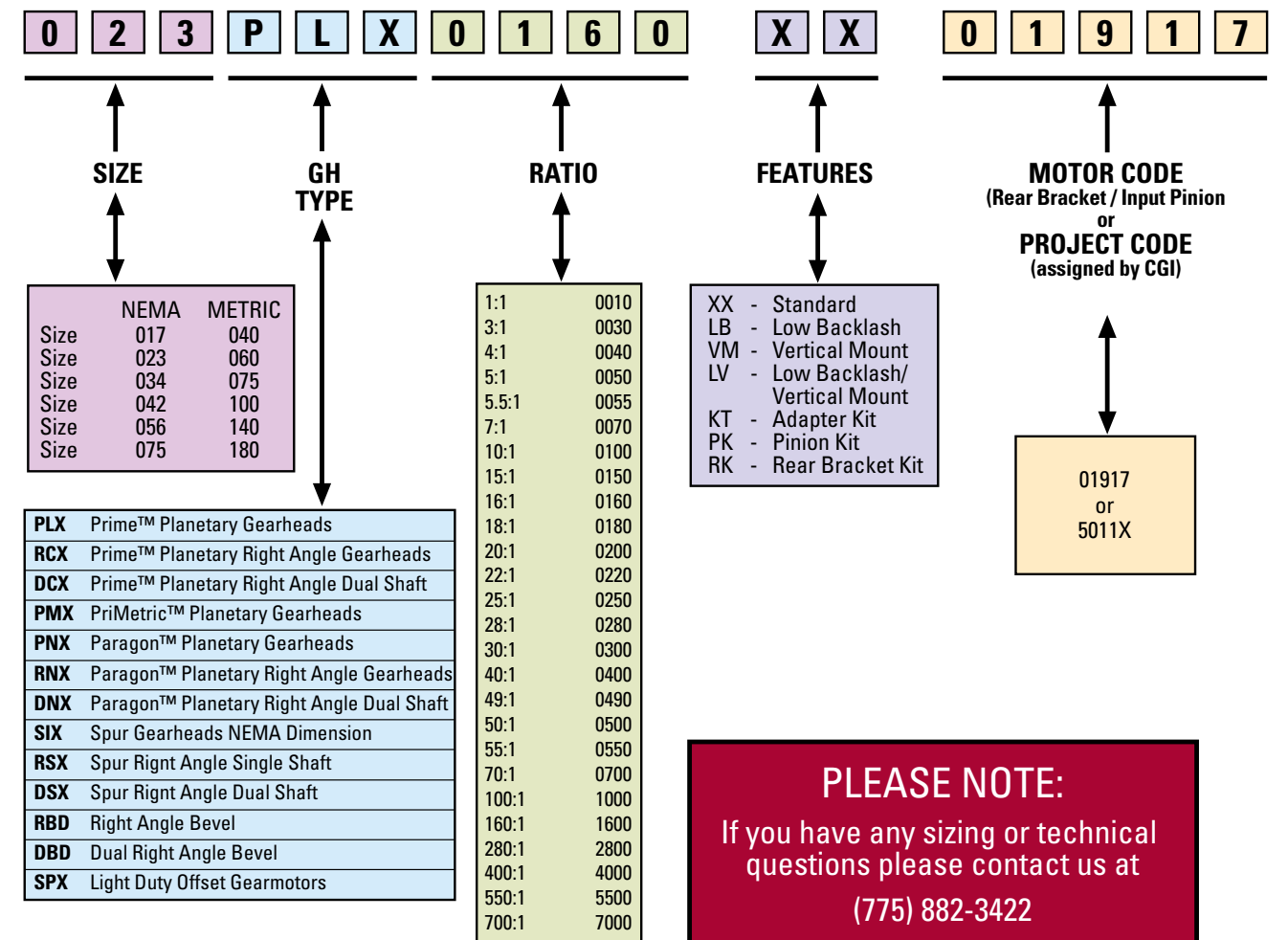

ALL SPECIFICATIONS SUBJECT TO CHANGE.



## INERTIA MATCHING

There are several rules that apply to the acceleration responsiveness of a gearmotor and external load system. (See Inertia Matching Example on page 39.) They are as follows:

### FOR STEP MOTORS (RULE 1 AND 2)

**RULE 1:** A system will respond "very fast" if the "System Inertia" is 1 to 3 times larger than the motor's inertia.

**RULE 2:** A system will respond "acceptably fast" if the "System Inertia" is between 3 and 10 times larger than the motor's inertia.

### FOR SERVO MOTORS (RULE 3 AND 4)

**RULE 3:** A system will respond "very fast" if the "System Inertia" is 1 to 5 times larger than the motor's inertia. Some high performance motor manufacturers state that very fast acceleration response can be obtained with reflected inertia matches as high as 10 times.

**RULE 4:** A system will respond "acceptably fast" if the "System Inertia" is between 6 and 10 times larger than the motor's inertia. Some high performance motor manufacturers state that acceptably fast response can be obtained with reflected inertia matches as high as 20 times.

Once the "System Inertia" is calculated, divide this by the motor's inertia, take the resultant number and see how it compares with the rules above to get a close approximation of the overall system responsiveness that you require.

## RADIAL AND AXIAL BEARING LOAD RATINGS

Our radial and axial bearing load information for each gearhead was calculated based on the dynamic load ratings for our bearing systems. Besides lubrication, bearing life is also affected by running speed (rpm) and applied load (radial or axial). Keeping required hours of bearing operation as a constant, as rpm increases, bearing load capacity decreases and vice versa (note: static loads do not apply). Additionally, for gearhead applications, output shaft bearings are affected by the location of any applied radial load on the output shaft. As constant radial load on the output shaft is placed farther from the gearhead output face, the resultant radial load at the bearings increases.

Note: The radial and axial bearing load limit information is provided for singular load components only (not combined axial and radial loads). When combining the load components, it is safe to combine a maximum of one component with only 10% of maximum of the other component. (i.e. 100% of the maximum radial load limit can be combined with only 10% of the maximum axial load limit and vice versa). Consult CGI, Inc. if the second component (axial/radial) exceeds 10% of the first component's load.

## GEARHEAD / MOTOR MOUNTING

Any motor matching the mounting dimensions as shown below will attach to any of our Inline Spur, Prime™ Planetary, or Paragon™ Planetary gearheads quickly and easily. If the motor you have selected has a different mounting face than shown, an appropriate adapter can be manufactured to meet your motor's exact mounting surface specifications.

All Gearheads come with a complete mounting kit which includes all hardware necessary for direct attachment to the motor along with easy to follow instruction. The Clamp-On Pinion and Balanced Collar simply slip onto the motor-shaft. The clamp is then fastened by two (2) allen head screws. The motor is then slipped into the gearhead and is held in place by four (4) mounting bolts. This process should take a few minutes at most. No matching or additional components are required.

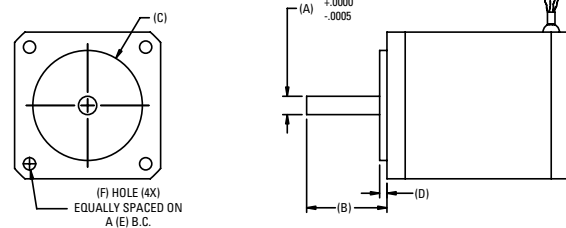

ITEM	DIMENSION	NEMA MOTOR MOUNTING DIMENSIONS (INCHES)					
		17	23	34	42	56	75
A	MOTOR SHAFT DIAMETER	.1968	.250	.375	.625	1.125	1.260
B	MOTOR SHAFT LENGTH*	.945	.810	1.250	1.380	2.375	2.283
C	PILOT DIAMETER	.866	1.500	2.875	2.186	4.500	7.087
D	PILOT LENGTH*	.080	.094	.094	.094	.125	.160
E	MOUNTING BOLT CIRCLE	1.725	2.625	3.875	4.950	7.000	8.464
F	BOLT HOLE SIZE	4-40 UNC	.195	.218	.281	.406	.551

\* These dimensions can be less than value indicated.



## INERTIA MATCHING (continued)

One important consideration when choosing a gearhead for your application is proper inertia matching. When an external load has a large inertia and it must accelerate and decelerate responsively, a gearhead with the

properly calculated inertia match will accomplish the task. A selected gear ratio will effectively reduce the external load inertia at the motor shaft by an inverse of the square of the gear ratio (see formula below).

### INERTIA MATCHING EXAMPLE

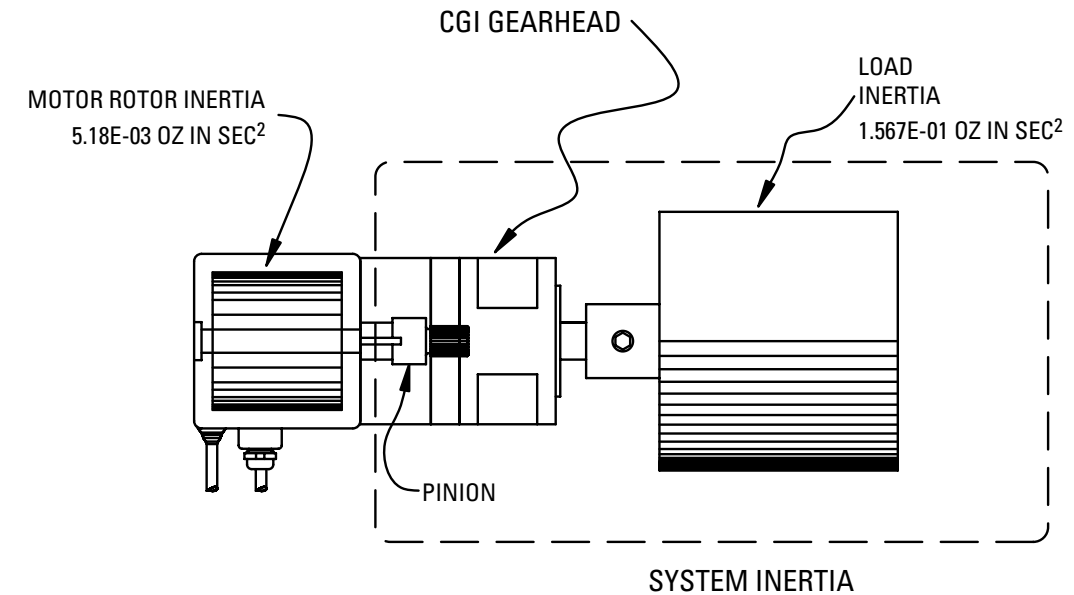

### FORMULA:

$$\text{SYSTEM INERTIA} = \text{GEARHEAD INERTIA} + \text{PINION INERTIA} + \frac{\text{LOAD INERTIA}}{(\text{GEAR RATIO})^2}$$

### GIVEN:

SIZE 23 5.5:1 PRIME GEARHEAD INERTIA = 1.746E-04 OZ IN SEC<sup>2</sup>  
 SIZE 23 5.5:1 PRIME PINION INERTIA = 9.062E-04 OZ IN SEC<sup>2</sup>  
 LOAD INERTIA = 1.567E-01 OZ IN SEC<sup>2</sup>  
 MOTOR ROTOR INERTIA = 5.18E-03 OZ IN SEC<sup>2</sup>

### SOLUTION:

$$\text{SYSTEM INERTIA} = 1.746E-04 \text{ OZ IN SEC}^2 + 9.062E-04 \text{ OZ IN SEC}^2 + \frac{1.567E-01 \text{ OZ IN SEC}^2}{(5.5)^2}$$

$$\text{SYSTEM INERTIA} = 6.26E-03 \text{ OZ IN SEC}^2$$

$$\text{RATIO OF THE SYSTEM INERTIA TO (:) THE MOTOR ROTOR INERTIA} = (6.26E-03 \text{ OZ IN SEC}^2) : (5.18E-03 \text{ OZ IN SEC}^2)$$

-OR-

1.2 TO 1 (INERTIA MATCH)

(IDEAL INERTIA MATCH OF 1:1 YIELDS A VERY FAST SYSTEM RESPONSE)

### OTHER APPLICATION PARAMETERS TO CONSIDER:

- TORQUE REQUIREMENTS
- SPEED REQUIREMENTS
- RESPONSE REQUIREMENTS
- STIFFNESS REQUIREMENTS
- RESOLUTION REQUIREMENTS

# APPLICATION FLOWCHART

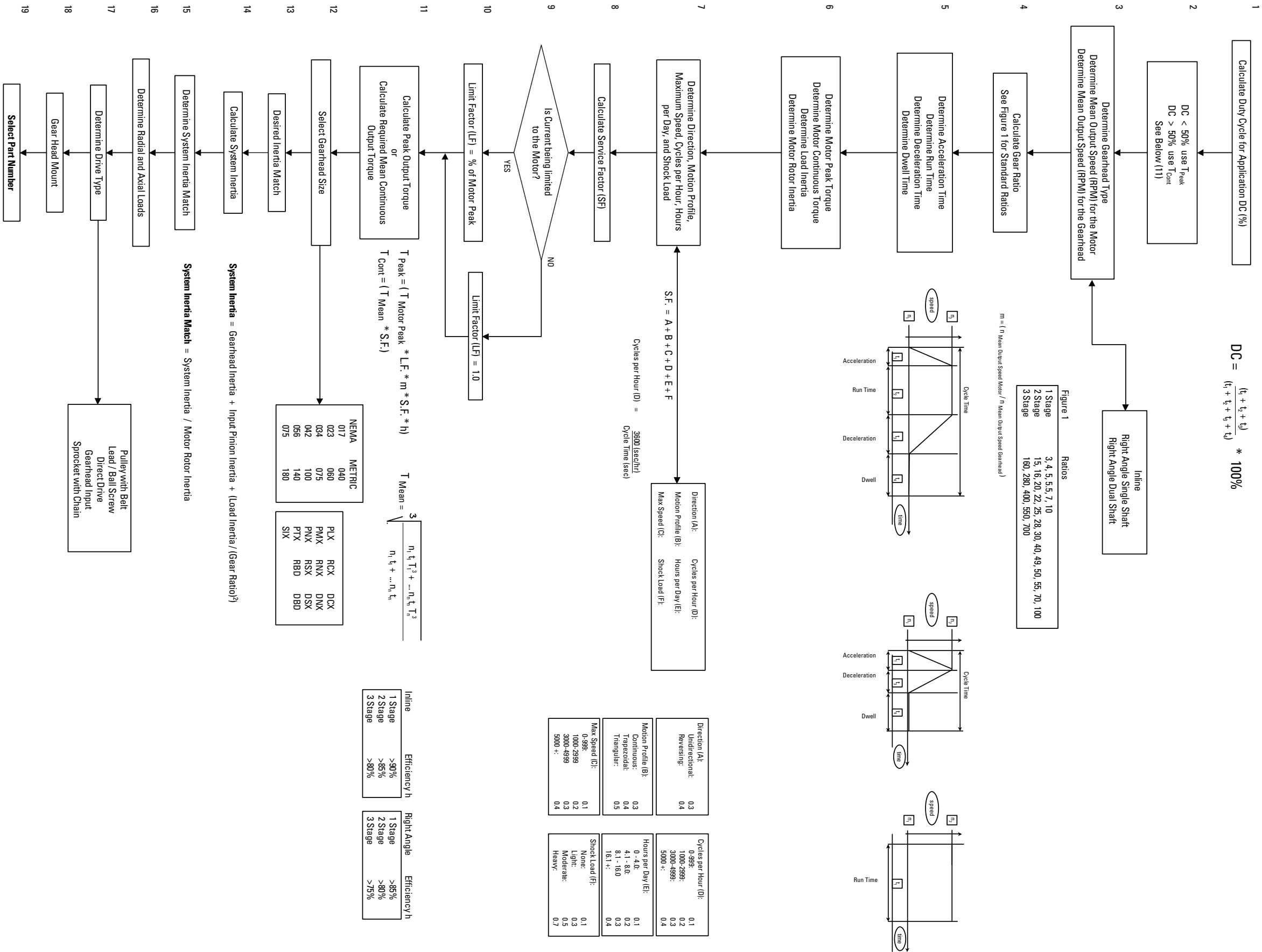

**General Information**

Customer Name: \_\_\_\_\_ Fax #: \_\_\_\_\_ CGI Ship Date: \_\_\_\_\_  
 Buyer Contact: \_\_\_\_\_ Phone #: \_\_\_\_\_ Dock Date: \_\_\_\_\_  
 Technical Contact: \_\_\_\_\_ Phone #: \_\_\_\_\_ Ship Via: \_\_\_\_\_  
 Purchase Order #: \_\_\_\_\_ Your Project #: \_\_\_\_\_ CGI Part #: \_\_\_\_\_  
 Gearhead Type: \_\_\_\_\_ Gearhead Size: \_\_\_\_\_ Ratio: \_\_\_\_\_

**Application Information**

Motor Manufacturer: \_\_\_\_\_  
 Motor Model #: \_\_\_\_\_  
 Motor Size: \_\_\_\_\_  
 Maximum Motor Speed: \_\_\_\_\_  
 Motor Print Attached?  Yes  No  
 NEMA Motor:  Yes  No  Not Sure

*Note: Any specials (non-cataloged gearheads) send motor print*

**Special Requirements**

OP – Output \_\_\_\_\_  
 FB – Front Bracket \_\_\_\_\_  
 RB – Rear Bracket \_\_\_\_\_  
 Material \_\_\_\_\_  
 Other \_\_\_\_\_

What is the external load inertia? (oz. in sec<sup>2</sup>): \_\_\_\_\_  
 Accel time to top speed? (sec.): \_\_\_\_\_  
 Decel Time? (sec.): \_\_\_\_\_ Dwell Time? (sec.): \_\_\_\_\_  
 Continuous Torque Rating of motor (in. lbs.): \_\_\_\_\_  
 Is it mounted?:  Vertically or  Horizontally?  
 Peak Torque Rating of motor (in. lbs.): \_\_\_\_\_  
 Is the current being limited to the motor?  Yes  No  
 If yes, to what peak torque value is it limited? (in. lbs.): \_\_\_\_\_  
 Gearhead output speed for application? (rpm): \_\_\_\_\_  
 Radial load on output shaft of gearhead (lbs.): \_\_\_\_\_  
 Axial load (lbs.): \_\_\_\_\_  
 Briefly describe your application: \_\_\_\_\_  
 \_\_\_\_\_  
 \_\_\_\_\_

Drive Type:  Pulley w/ Belt  Lead / Ball Screw  Direct Drive  Gearhead Input  Sprocket w/ Chain

**Service Factor**

DIRECTION		MOTION PROFILE		MAX SPEED (RPM)		CYCLES / HOUR		HOURS / DAY		SHOCK LOAD	
Unidirectional	.3	Continuous	.3	0-999	.1	0-999	.1	.1 - 4.0	.1	None	.1
Reversing	.4	Trapezoidal	.4	1000-2999	.2	1000-2999	.2	4.1 - 8.0	.2	Light	.3
		Triangular	.5	3000-4999	.3	3000-4999	.3	8.1 - 16.0	.3	Moderate	.5
				5000 +	.4	5000 +	.4	16.1 +	.4	Heavy	.7

Service Factor = Sum of all Elements \_\_\_\_\_ Circle the Numbers Above

Customer Sign Off: \_\_\_\_\_

Sales: \_\_\_\_\_

Engineering: \_\_\_\_\_

# Certificate of Registration

QUALITY MANAGEMENT SYSTEM - ISO 9001:2000

This is to certify that:

CGI Inc.  
 3400 Arrowhead Drive  
 Carson City  
 Nevada  
 89706  
 USA

Holds Certificate No: **FM 66031**

and operates a Quality Management System which complies with the requirements of ISO 9001:2000 for the following scope:

The design, manufacture and distribution of precision power transmission component parts and gear assemblies for motion control and automation applications.

For and on behalf of BSI:

*Todd R. Valle*

President, BSI Management Systems America, Inc.

Originally Registered: 03/14/2002

Latest Issue: 07/30/2008

Expiry Date: 08/14/2011



Page: 1 of 1



This certificate remains the property of BSI and shall be returned immediately upon request. An electronic certificate can be authenticated [online](#). Printed copies can be validated at [www.bsigroup.com/ClientDirectory](http://www.bsigroup.com/ClientDirectory). To be read in conjunction with the scope above or the attached appendix. Americas Headquarters: 12110 Sunset Hills Road, Suite 200, Reston, VA 20190, USA.



# WARRANTY TERMS AND CONDITIONS

CGI, Inc. warrants all standard Gearheads, manufactured to be free of defects in materials and workmanship for the periods shown below, when used within Product Specifications and under Normal Operating Conditions, as determined by CGI, Inc. and within the provisions outlined below.

CGI, Inc. warrants all standard PriMetric and Prime Planetary Gearheads for a five (5) year period from date of purchase.

CGI, Inc. warrants all standard Spur Inline, Power Tube and Paragon Planetary Gearheads for a two (2) year period from date of purchase.

CGI, Inc. warrants all standard Spur Offset Gearheads for a one (1) year period from the date of purchase.

1. CGI, Inc. will repair or replace, at its sole discretion, any of its standard catalog products, which CGI agrees, in writing, are nonconforming. Any claims by Buyer for omissions or shortages in a shipment or that product is nonconforming shall be waived, unless Seller received written notice thereof within thirty (30) days after Buyer's receipt of the shipment, or as authorized by Seller, in writing.
2. All product returned to Seller's facility must have a Return Authorization (RA) Number. Buyer must contact CGI, Inc. before sending product in for evaluation, repair, replacement or modification. Seller assumes no liability for packages returned without proper authorization. The RA number should be clearly marked on the outside of all packages being returned. Product should be properly packaged. CGI, Inc. will not accept responsibility for damage incurred during removal, installation, shipping or handling of returned product.
3. Buyer shall pay costs of transportation for nonconforming product which is returned to Seller's facility, unless prior written authorization is obtained from Seller. Seller shall pay for costs of transportation on warranty repairs or replacements, using standard ground transport, unless agreed to by Seller, in writing.
4. Seller's sole liability (whether based upon breach of contract, negligence, strict product liability or otherwise) is exclusively limited to the repair, replacement or the refund of the purchase price paid for defective product, at the Seller's discretion. Seller shall not be liable for punitive damages, special, consequential, incidental, indirect damages

or lost profits associated with said product. EXCEPT AS OTHERWISE SET FORTH HEREIN, SELLER DISCLAIMS ALL EXPRESS OR IMPLIED WARRANTIES INCLUDING, BUT NOT LIMITED TO, WARRANTIES OF MERCHANTABILITY AND FITNESS FOR A PARTICULAR USE OR PURPOSE.

5. Any CGI, Inc. product which has been damaged due to misuse, abuse, negligence, improper installation or has been modified, dismantled or disassembled by Buyer, in any manner shall void coverage by this warranty. Seller shall not accept returned products under this warranty as a result of life-cycle, reliability testing or processing outside of Normal Operating Conditions, nor custom, nonstandard or any product that has otherwise been modified at the request of or by Buyer, unless previously agreed to in writing by Seller.
6. Buyer agrees that any values of expected life furnished by Seller to Buyer are strictly estimates based on theoretical calculations, load averaging via RMC (root mean cubed) or other industry standard calculation methods. Such estimated values are furnished for Buyer's convenience only and on the express condition that such values do not constitute any representation, warranty or guarantee by Seller whatsoever that such values will be realized in Buyer's application. Any estimated values of expected life, oral or written information, opinions, evaluations, consultations, or cooperation of Seller or any designs, specifications, standards, performance requirements, requirements of third parties or other information of any kind furnished or communicated by Buyer, or its representatives, Buyer specifically agrees that it is Buyer's sole responsibility to select and evaluate the correct product and other items for use in Buyer's application.
7. Seller and Buyer agree that any and all claims, disputes and controversies concerning any product purchased by Buyer, as well as each of the terms set forth herein, shall be construed and interpreted in accordance with the laws of the State of Nevada without resort to conflict of laws principles. The parties further agree that venue with respect to any such claims and/or actions shall be in the state of federal courts having jurisdiction in Carson County, Nevada. Buyer waives any challenges to the jurisdiction of such courts and agrees to submit to the personal jurisdiction thereof.

# PRECISION CONSTRUCTION FEATURES

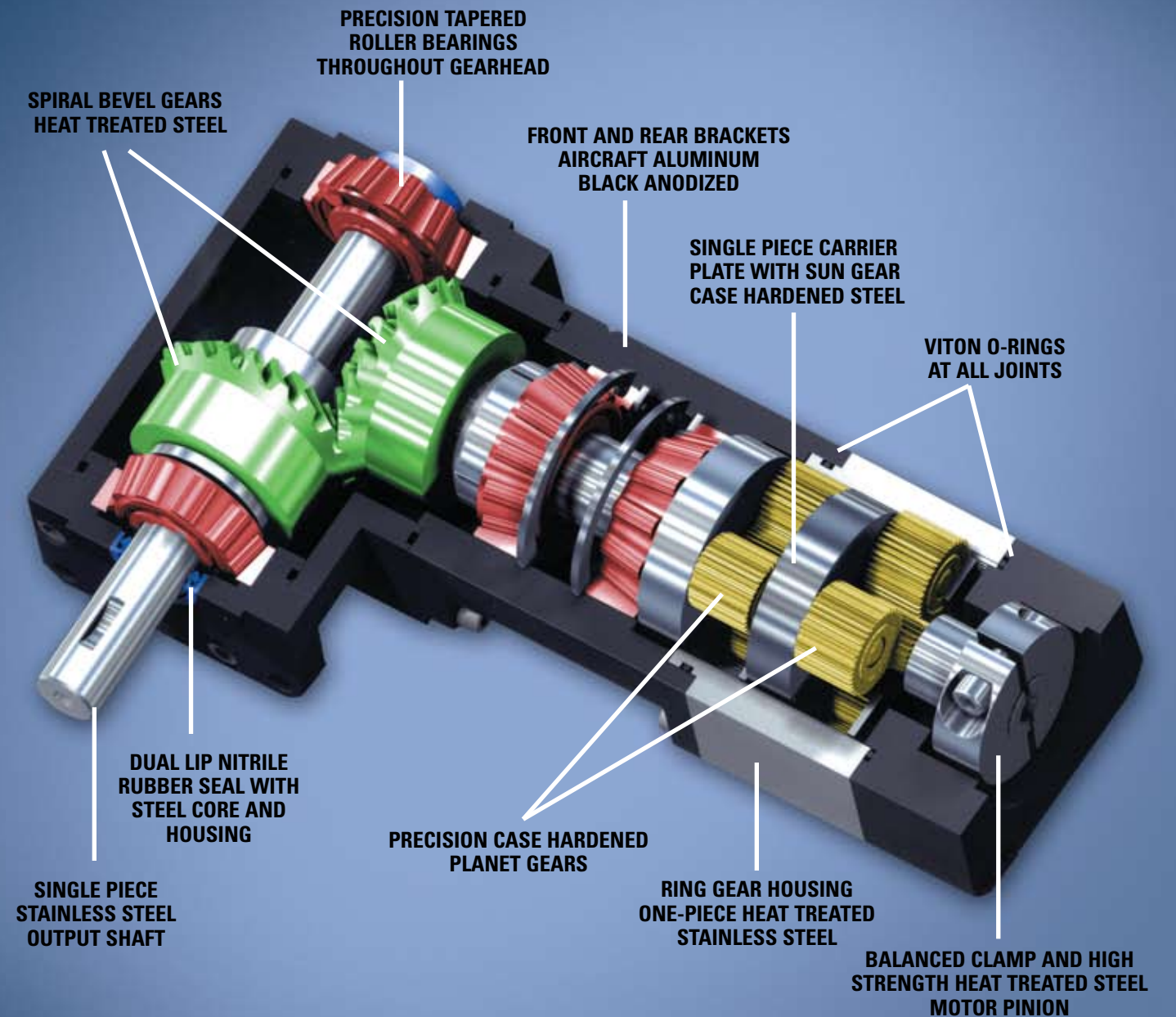

PRIME™ PLANETARY GEARHEAD PICTURED.

# PRIME™



Quality at Every Turn

**DESIGNERS AND MANUFACTURERS OF PRECISION MOTION CONTROL PRODUCTS**

**CGI, INC. • 3400 Arrowhead Drive • Carson City, Nevada 89706  
Tel 775.882.3422 • Fax 775.882.9599 • [www.cgimotion.com](http://www.cgimotion.com)**

REVISION SUMMER 2010