

Fall 2008

# New Product Guide

PREDATOR • RAPTOR • RAPTOR EP • VICTORY



Quality at Every Turn

800.568.GEAR (4327) • [www.cgimotion.com](http://www.cgimotion.com)

Welcome to CGI's newest innovation in motion control gearheads, the result of more than 40 years of gear design and manufacturing experience, as well as proven performance in the field.

Our new Predator and Raptor planetary gearheads utilize a revolutionary optimized gear design, providing world-class performance and torque density, combined with the most popular housing and mounting features. In addition, our well-known Victory planetary gearhead offers an economical, compact and efficient design, while continuing to utilize advanced materials and provide high torque density.

CGI's Engineering and Manufacturing is 100% USA based, and we operate under an ISO 9001:2000 certified quality management system. Customers around the world depend on us for high-quality products, quick customizations, exceptional engineering support, and outstanding service and value—and so can you.



ISO 9001:2000  
FM 66031



American  
Gear Manufacturers  
Association

## Table of Contents

Introduction .....	inside cover
Predator Design Highlights .....	page 3
Predator Planetary Gearhead .....	page 4-5
Raptor Planetary Gearhead .....	page 6-7
Raptor EP Planetary Gearhead .....	page 8-9
Victory Planetary Gearhead .....	page 10-11
Radial and Axial Load Specifications .....	page 12
Selection Chart .....	page 13
Application Data Sheet .....	page 14
Model Number and Ordering Information .....	page 15



Quality at Every Turn

# Design Highlights

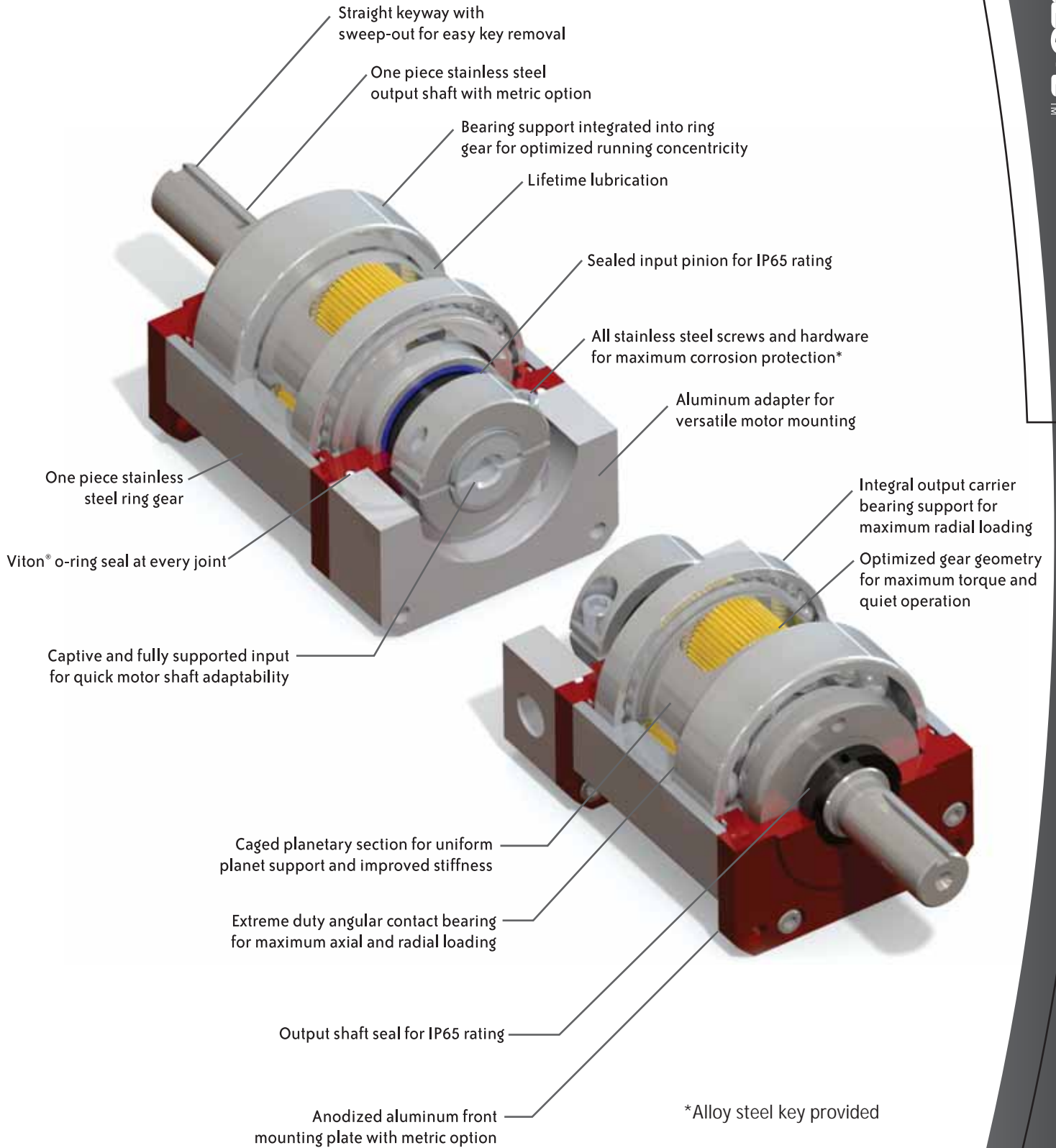



### Design Features

- Single-piece construction utilized throughout
- IP65 sealed with Viton® seals at each joint
- High torque design with optimized gear geometry
- Advanced materials and heat treatments
- High torsional stiffness design
- Mounting in any direction
- Captive, bearing supported input pinion
- Simplified quick installation
- NEMA and Metric configurations standard

### Performance Specifications

023PRX (NEMA) / 060PRX (METRIC)				034PRX (NEMA) / 090PRX (METRIC)			
Ratio	T <sub>NOM</sub> (1) In-lbs (Nm)	T <sub>MAX ACCEL</sub> In-lbs (Nm)	T <sub>E-STOP</sub> (2) In-lbs (Nm)	T <sub>NOM</sub> (1) In-lbs (Nm)	T <sub>MAX ACCEL</sub> In-lbs (Nm)	T <sub>E-STOP</sub> (2) In-lbs (Nm)	
1 STAGE	4:1	420 (48)	530 (60)	1069 (121)	1487 (168)	1874 (212)	3548 (401)
	5:1	360 (41)	455 (51)	1043 (118)	1328 (150)	1674 (189)	3481 (393)
	7:1	250 (28)	315 (36)	964 (109)	895 (101)	1128 (127)	2954 (334)
	10:1	165 (19)	210 (24)	720 (81)	580 (66)	732 (83)	2564 (290)
2 STAGE	16:1	420 (48)	530 (60)	1069 (121)	1487 (168)	1874 (212)	3548 (401)
	20:1	420 (48)	530 (60)	1069 (121)	1487 (168)	1874 (212)	3548 (401)
	25:1	360 (41)	455 (51)	1043 (118)	1328 (150)	1674 (189)	3481 (393)
	28:1	420 (48)	530 (60)	1069 (121)	1487 (168)	1874 (212)	3548 (401)
	35:1	360 (41)	455 (51)	1043 (118)	1328 (150)	1674 (189)	3481 (393)
	40:1	420 (48)	530 (60)	1069 (121)	1487 (168)	1874 (212)	3548 (401)
	50:1	360 (41)	455 (51)	1043 (118)	1328 (150)	1674 (189)	3481 (393)
	70:1	286 (32)	360 (41)	964 (109)	1029 (116)	1297 (146)	2954 (334)
100:1	192 (22)	241 (27)	720 (81)	674 (76)	849 (96)	2564 (290)	
Gearbox Weight (lbs)		1 stage 2.8 lbs / 2 stage 3.8 lbs		1 stage 9.1 lbs / 2 stage 12.7 lbs			
Torsional Stiffness (3)		20 in-lbs/arc-min		80 in-lbs/arc-min			
Input Speed			6500 RPM Maximum				
Backlash (arc-min)			4 (1 stage), 6 (2 stage)				
IP Rating			IP65				
Service Life			>20,000 HOURS				
Efficiency (4)			1 stage >95% 2 stage >90%				
Operating Temperature			-40°F to +250°F				
Shaft Loads			See Tables on Page 12				

1. All torque ratings are based upon 3,000 RPM nominal input speed, and 20,000 hours minimum service life.

2. E-STOP torque rating is limited to 1,000 occurrences.

3. Torsional Stiffness rating varies by type and ratio. Specified rating based on Metric, 5:1 ratio.

4. Efficiency rated at 3,000 RPM input speed, at Nominal Rated Torque.

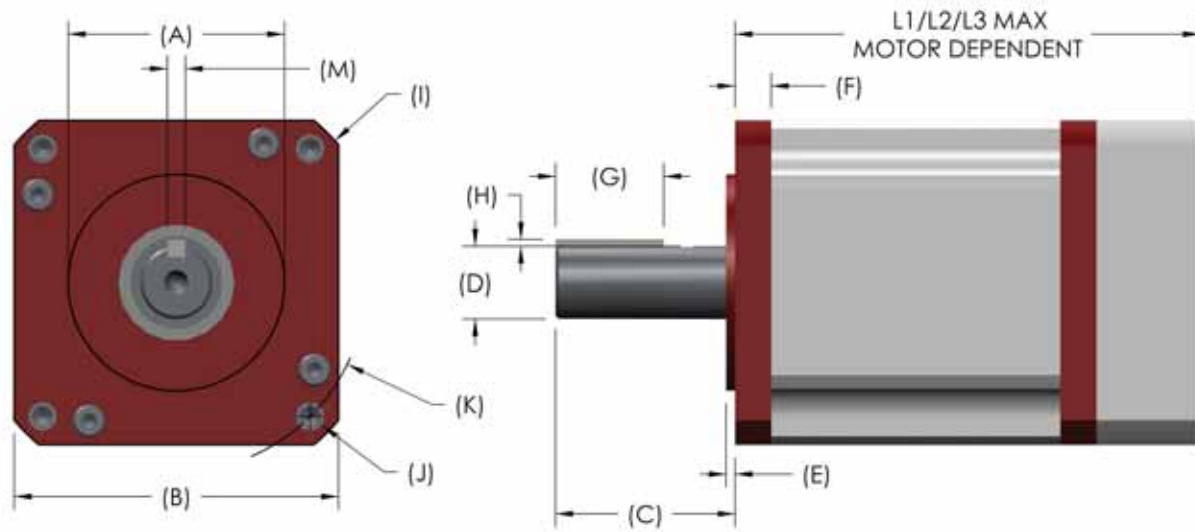

## Gearhead Dimensions

Dimension	Code	023PRX	060PRX	034PRX	090PRX
		Inch (mm)	Metric (in)	Inch (mm)	Metric (in)
Pilot Diameter (+.000/-0.002 in)	A	1.500 (38)	50 (1.969)	2.875 (73)	80 (3.150)
Square Flange	B	2.25 (57)	60 (2.36)	3.45 (87)	90 (3.540)
Shaft Length	C	1.25 (32)	30 (1.18)	1.50 (38)	40 (1.57)
Shaft Diameter (+.0000/-0.0005 in)	D	0.500 (13)	16 (0.6299)	0.75 (19)	22 (0.8661)
Pilot Length	E	0.062 (2)	3 (0.118)	0.062 (2)	3 (0.118)
Flange Thickness	F	0.250 (6.4)	6.4 (0.250)	0.375 (10)	9 (0.375)
Key Length	G	0.75 (19)	20 (0.79)	0.98 (25)	25 (0.98)
Key Width (3)	M	0.125 (3.18)	5 (0.1969)	0.188 (5)	6 (0.2362)
Key Height	H	0.047 (1)	2 (0.079)	0.081 (2)	2.5 (0.098)
Housing Diameter	I	2.95 (75)	80 (3.15)	4.58 (116)	116 (4.58)
Bolt Hole Diameter	J	0.205 (5)	5.6 (0.220)	0.220 (5.6)	6.6 (0.260)
Bolt Circle Diameter	K	2.625 (67)	70 (2.756)	3.875 (98)	100 (3.937)
Gearhead Length (1)	L1	3.23 (82)	82 (3.230)	4.73 (120)	120 (4.730)
	L2	4.38 (111)	111 (4.380)	6.50 (165)	165 (6.500)

## Moment of Inertia Table (2) (oz-in-sec<sup>2</sup>)

Ratio	023PRX	060PRX	034PRX	090PRX
4:1	2.190E-03	2.206E-03	1.554E-02	1.557E-02
5:1	1.887E-03	1.896E-03	1.310E-02	1.312E-02
7:1	1.661E-03	1.666E-03	1.117E-02	1.118E-02
10:1	1.547E-03	1.550E-03	1.018E-02	1.019E-02
16:1	1.852E-03	1.853E-03	1.303E-02	1.303E-02
20:1	1.670E-03	1.671E-03	1.149E-02	1.149E-02
25:1	1.659E-03	1.659E-03	1.139E-02	1.139E-02
28:1	1.551E-03	1.551E-03	1.036E-02	1.035E-02
35:1	1.545E-03	1.545E-03	1.030E-02	1.030E-02
40:1	1.493E-03	1.493E-03	9.778E-03	9.778E-03
50:1	1.490E-03	1.490E-03	9.753E-03	9.753E-03
70:1	1.488E-03	1.488E-03	9.734E-03	9.734E-03
100:1	1.487E-03	1.487E-03	9.724E-03	9.724E-03

(1) Gearhead Length based on NEMA motor mounting.

(2) Gearhead inertia values shown include pinion, clamp and sleeve, and are for standard NEMA mounting.

(3) Key Width tolerance for English keys is: +.001 / -.000 in.  
Key Width tolerance for Metric keys is: +.000 / -.0012 in.

• All specifications are subject to change without prior notice.



Quality at Every Turn



### Design Features

- Improved design for stiffness and loading
- High torque gear geometry
- Advanced materials and heat treatments
- IP65 sealed
- Mounting in any direction
- Captive input pinion
- Simplified quick installation
- NEMA and Metric configurations standard

### Performance Specifications

023RTX (NEMA) / 060RTX (METRIC)				034RTX (NEMA) / 090RTX (METRIC)				
	Ratio	T <sub>NOM</sub> (1) In-lbs (Nm)	T <sub>MAX ACCEL</sub> In-lbs (Nm)	T <sub>E-STOP</sub> (2) In-lbs (Nm)	T <sub>NOM</sub> (1) In-lbs (Nm)	T <sub>MAX ACCEL</sub> In-lbs (Nm)	T <sub>E-STOP</sub> (2) In-lbs (Nm)	
1 STAGE	4:1	395 (45)	468 (53)	947 (107)	1452 (164)	1829 (207)	3473 (392)	
	5:1	340 (38)	400 (45)	926 (105)	1274 (144)	1605 (181)	3316 (375)	
	7:1	231 (26)	280 (32)	861 (97)	863 (98)	1088 (123)	2821 (319)	
	10:1	150 (17)	190 (22)	720 (81)	559 (63)	704 (80)	2456 (277)	
2 STAGE	16:1	395 (45)	468 (53)	947 (107)	1452 (164)	1829 (207)	3473 (392)	
	20:1	395 (45)	468 (53)	947 (107)	1452 (164)	1829 (207)	3473 (392)	
	25:1	340 (38)	400 (45)	926 (105)	1274 (144)	1605 (181)	3316 (375)	
	28:1	395 (45)	468 (53)	947 (107)	1452 (164)	1829 (207)	3473 (392)	
	35:1	340 (38)	400 (45)	926 (105)	1274 (144)	1605 (181)	3316 (375)	
	40:1	395 (45)	468 (53)	947 (107)	1452 (164)	1829 (207)	3473 (392)	
	50:1	340 (38)	400 (45)	926 (105)	1274 (144)	1605 (181)	3316 (375)	
	70:1	265 (30)	320 (36)	861 (97)	993 (112)	1251 (141)	2821 (319)	
3 STAGE (5)	100:1	175 (20)	221 (25)	720 (81)	642 (73)	810 (92)	2456 (277)	
	160:1	395 (45)	468 (53)	947 (107)	1452 (164)	1829 (207)	3473 (392)	
	280:1	395 (45)	468 (53)	947 (107)	1452 (164)	1829 (207)	3473 (392)	
	400:1	395 (45)	468 (53)	947 (107)	1452 (164)	1829 (207)	3473 (392)	
	500:1	340 (38)	400 (45)	926 (105)	1274 (144)	1605 (181)	3316 (375)	
	700:1	265 (30)	320 (36)	861 (97)	993 (112)	1251 (141)	2821 (319)	
Torsional Stiffness (3)				15 in-lbs/arc-min	70 in-lbs/arc-min			
Gearbox Weight (lbs)				1 stage 3.3 lbs / 2 stage 3.9 lbs / 3 stage 4.7 lbs	1 stage 9.6 lbs / 2 stage 13 lbs / 3 stage 16.3 lbs			
Input Speed				6500 RPM Maximum				
Backlash (arc-min)				4 (1 stage), 6 (2 stage), 8 (3 stage)				
IP Rating				IP65				
Service Life				>15,000 HOURS				
Efficiency (4)				1 stage >95% / 2 stage >90% / 3 stage >85%				
Operating Temperature				-40°F to +250°F				
Shaft Loads				See Tables on Page 12				

1. All torque ratings are based upon 3,000 RPM nominal input speed, and 15,000 hours minimum service life.  
 2. E-STOP torque rating is limited to 1,000 occurrences.  
 3. Torsional Stiffness rating varies by type and ratio. Specified rating based on Metric, 5:1 ratio.  
 4. Efficiency rated at 3,000 RPM input speed, at Nominal Rated Torque.  
 5. Other ratios available.

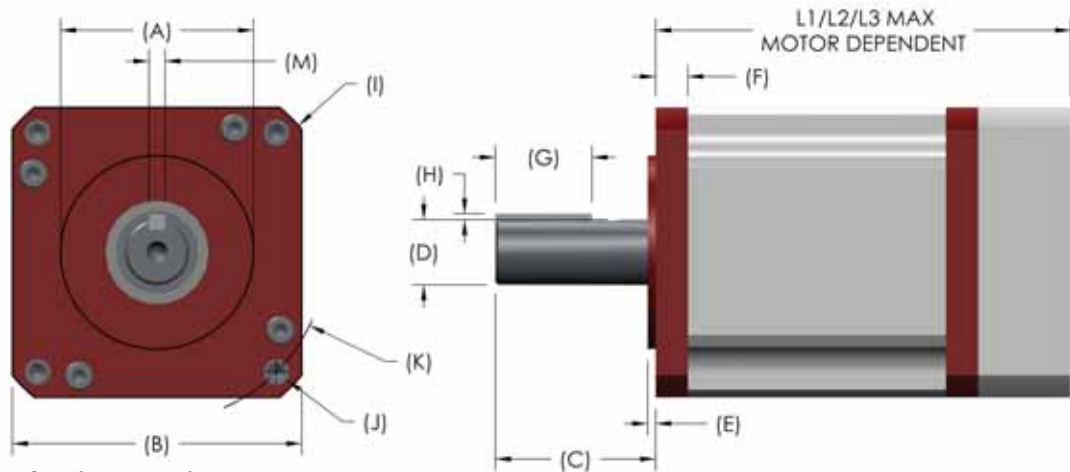

## Gearhead Dimensions

Dimension	Code	023RTX		060RTX		034RTX		090RTX	
		Inch	(mm)	Metric	(in)	Inch	(mm)	Metric	(in)
Pilot Diameter (+.000/-0.002 in)	A	1.500	(38)	50	(1.969)	2.875	(73)	80	(3.150)
Square Flange	B	2.25	(57)	60	(2.36)	3.450	(87)	90	(3.540)
Shaft Length	C	1.25	(32)	30	(1.18)	1.500	(38)	40	(1.57)
Shaft Diameter (+.0000/-0.0005 in)	D	0.500	(12.7)	16	(0.6299)	0.750	(19)	22	(0.8661)
Pilot Length	E	0.062	(2)	3	(0.118)	0.062	(2)	3	(0.118)
Flange Thickness	F	0.250	(6.4)	6.4	(0.250)	0.375	(9.5)	9.5	(0.375)
Key Length	G	0.75	(19)	20	(0.790)	0.980	(25)	25	(0.980)
Key Height	H	0.047	(1.2)	2	(0.079)	0.081	(2.06)	2.5	(0.098)
Key Width (3)	M	0.125	(3.18)	5	(0.1969)	0.188	(5)	6	(0.2362)
Housing Diameter	I	2.95	(75)	80	(3.15)	4.58	(116)	116	(4.58)
Bolt Hole Diameter	J	0.205	(5.2)	5.6	(0.220)	0.220	(5.6)	6.6	(0.260)
Bolt Circle Diameter	K	2.625	(67)	70	(2.756)	3.875	(98)	100	(3.937)
Gearhead Length (1)	L1	3.39	(86)	86	(3.39)	4.82	(122)	122	(4.82)
	L2	4.28	(109)	108	(4.28)	6.23	(158)	158	(6.23)
	L3	5.17	(131)	131	(5.17)	7.63	(193)	194	(7.63)

## Moment of Inertia Table (2) (oz-in-sec<sup>2</sup>)

Ratio	023RTX	060RTX	034RTX	090RTX
4:1	1.861E-03	1.868E-03	1.295E-02	1.297E-02
5:1	1.676E-03	1.680E-03	1.119E-02	1.121E-02
7:1	1.536E-03	1.538E-03	9.808E-03	9.816E-03
10:1	1.464E-03	1.465E-03	9.111E-03	9.115E-03
16:1	1.702E-03	1.702E-03	1.200E-02	1.200E-02
20:1	1.574E-03	1.575E-03	1.059E-02	1.059E-02
25:1	1.567E-03	1.567E-03	1.051E-02	1.052E-02
28:1	1.484E-03	1.485E-03	9.498E-03	9.498E-03
35:1	1.481E-03	1.481E-03	9.462E-03	9.462E-03
40:1	1.439E-03	1.439E-03	8.944E-03	8.944E-03
50:1	1.437E-03	1.437E-03	8.926E-03	8.926E-03
70:1	1.436E-03	1.436E-03	8.912E-03	8.912E-03
100:1	1.435E-03	1.435E-03	8.920E-03	8.920E-03
160:1	1.437E-03	1.437E-03	8.934E-03	8.934E-03
280:1	1.435E-03	1.435E-03	8.909E-03	8.909E-03
400:1	1.435E-03	1.435E-03	8.919E-03	8.919E-03
500:1	1.435E-03	1.435E-03	8.919E-03	8.919E-03
700:1	1.435E-03	1.435E-03	8.918E-03	8.918E-03

(1) Gearhead Length based on NEMA motor mounting.

(2) Gearhead inertia values shown include pinion, clamp and sleeve, and are for standard NEMA mounting.

(3) Key Width tolerance for English keys is: +.001 / -.000 in.  
Key Width tolerance for Metric keys is: +.000 / -.0012 in.

• All specifications are subject to change without prior notice.



Quality at Every Turn



### Design Features

- Metric extended pilot (EP) configuration
- High torque gear geometry
- Advanced materials and heat treatments
- Improved design for stiffness and loading
- Mounting in any direction
- Captive input pinion
- IP65 sealed
- Simplified quick installation

### Performance Specifications

060RTA (METRIC)				075RTA (METRIC)			
	T <sub>NOM</sub> (1)	T <sub>MAX ACCEL</sub>	T <sub>E-STOP</sub> (2)	T <sub>NOM</sub> (1)	T <sub>MAX ACCEL</sub>	T <sub>E-STOP</sub> (2)	
Ratio	In-lbs (Nm)	In-lbs (Nm)	In-lbs (Nm)	In-lbs (Nm)	In-lbs (Nm)	In-lbs (Nm)	
1 STAGE	4:1	395 (45)	468 (53)	947 (107)	1452 (164)	1829 (207)	3473 (392)
	5:1	340 (38)	400 (45)	926 (105)	1274 (144)	1605 (181)	3316 (375)
	7:1	231 (26)	280 (32)	861 (97)	863 (98)	1088 (123)	2821 (319)
	10:1	150 (17)	190 (22)	720 (81)	559 (63)	704 (80)	2456 (277)
2 STAGE	16:1	395 (45)	468 (53)	947 (107)	1452 (164)	1829 (207)	3473 (392)
	20:1	395 (45)	468 (53)	947 (107)	1452 (164)	1829 (207)	3473 (392)
	25:1	340 (38)	400 (45)	926 (105)	1274 (144)	1605 (181)	3316 (375)
	28:1	395 (45)	468 (53)	947 (107)	1452 (164)	1829 (207)	3473 (392)
	35:1	340 (38)	400 (45)	926 (105)	1274 (144)	1605 (181)	3316 (375)
	40:1	395 (45)	468 (53)	947 (107)	1452 (164)	1829 (207)	3473 (392)
	50:1	340 (38)	400 (45)	926 (105)	1274 (144)	1605 (181)	3316 (375)
	70:1	265 (30)	320 (36)	861 (97)	993 (112)	1251 (141)	2821 (319)
100:1	175 (20)	221 (25)	720 (81)	642 (73)	810 (91.5)	2456 (277)	
3 STAGE (5)	160:1	395 (45)	468 (53)	947 (107)	1452 (164)	1829 (207)	3473 (392)
	280:1	395 (45)	468 (53)	947 (107)	1452 (164)	1829 (207)	3473 (392)
	400:1	395 (45)	468 (53)	947 (107)	1452 (164)	1829 (207)	3473 (392)
	500:1	340 (38)	400 (45)	926 (105)	1274 (144)	1605 (181)	3316 (375)
	700:1	265 (30)	320 (36)	861 (97)	993 (112)	1251 (141)	2821 (319)
	Torsional Stiffness (3)	15 in-lbs/arc-min			70 in-lbs/arc-min		
Gearbox Weight (lbs)	1 stage 2.5 lbs / 2 stage 3.5 lbs / 3 stage 4.3 lbs			1 stage 6.9 lbs / 2 stage 10.4 lbs / 3 stage 13.6 lbs			

Input Speed	6500 RPM Maximum
Backlash (arc-min)	4 (1 stage), 6 (2 stage), 8 (3 stage)
IP Rating	IP65
Service Life	>15,000 HOURS
Efficiency (4)	1 stage >95% / 2 stage >90% / 3 stage >85%
Operating Temperature	-40°F to +250°F
Shaft Loads	See Tables on Page 12

1. All torque ratings are based upon 3,000 RPM nominal input speed, and 15,000 hours minimum service life.  
 2. E-STOP torque rating is limited to 1,000 occurrences.  
 3. Torsional Stiffness rating varies by type and ratio. Specified rating based on Metric, 5:1 ratio.  
 4. Efficiency rated at 3,000 RPM input speed, at Nominal Rated Torque.  
 5. Other ratios available.



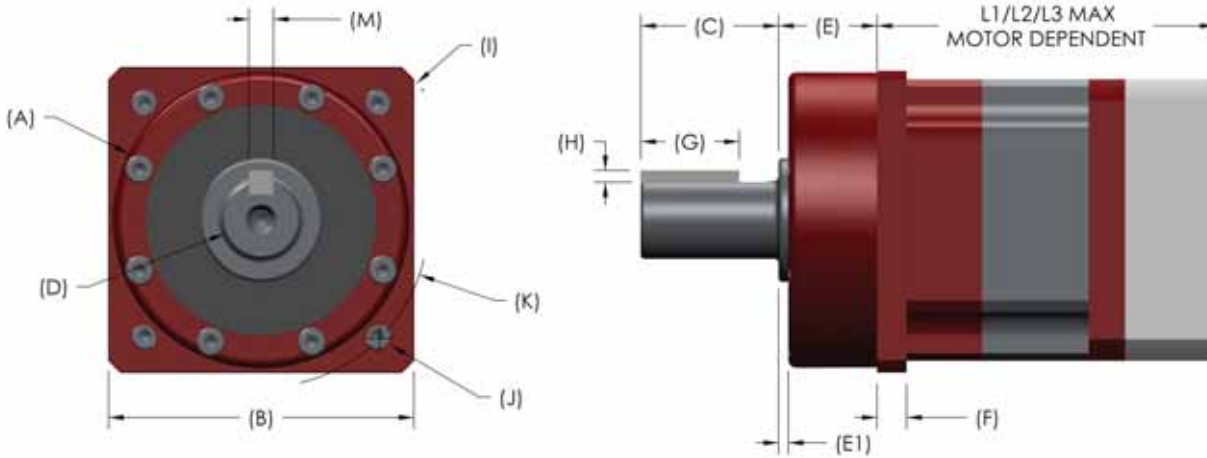

## Gearhead Dimensions

Dimension	Code	060RTA		075RTA	
		Metric	(in)	Metric	(in)
Pilot Diameter (+.000/- .002 in)	A	60	(2.362)	70	(2.756)
Square Flange	B	62	(2.44)	76	(2.99)
Shaft Length	C	28	(1.10)	36	(1.42)
Shaft Diameter (+.0000/- .0005 in)	D	16	(0.6299)	22	(0.8661)
Pilot Length	E	20	(0.787)	20	(0.787)
Step Length	E1	2	(0.079)	2.5	(0.098)
Flange Thickness	F	6	(0.236)	7	(0.276)
Key Length	G	20	(0.79)	25	(0.98)
Key Height	H	2	(0.079)	3	(0.115)
Key Width (3)	M	5	(0.1969)	6	(0.2362)
Housing Diameter	I	84	(3.32)	116	(4.58)
Bolt Hole Diameter	J	5.5	(0.217)	6.6	(0.260)
Bolt Circle Diameter	K	68	(2.677)	85	(3.346)
Gearhead Length (1)	L1	69	(2.70)	114	(4.46)
	L2	91	(3.60)	149	(5.88)
	L3	114	(4.49)	185	(7.28)

## Moment of Inertia Table (2) (oz-in-sec<sup>2</sup>)

Ratio	060RTA	075RTA	Ratio	060RTA	075RTA
4:1	1.886E-03	1.246E-02	40:1	1.439E-03	8.939E-03
5:1	1.692E-03	1.088E-02	50:1	1.437E-03	8.923E-03
7:1	1.544E-03	9.646E-03	70:1	1.436E-03	8.911E-03
10:1	1.468E-03	9.016E-03	100:1	1.435E-03	8.919E-03
16:1	1.703E-03	1.198E-02	160:1	1.437E-03	8.934E-03
20:1	1.575E-03	1.057E-02	280:1	1.435E-03	8.909E-03
25:1	1.568E-03	1.050E-02	400:1	1.435E-03	8.919E-03
28:1	1.485E-03	9.488E-03	500:1	1.435E-03	8.919E-03
35:1	1.481E-03	9.455E-03	700:1	1.435E-03	8.918E-03

(1) Gearhead Length based on NEMA motor mounting.

(2) Gearhead inertia values shown include pinion, clamp and sleeve, and are for standard NEMA mounting.

(3) Key Width tolerance for English keys is: +.001 / -.000 in.  
Key Width tolerance for Metric keys is: +.000 / -.0012 in.

• All specifications are subject to change without prior notice.



Quality at Every Turn



### Design Features

- Economical true planetary design
- High torque gear geometry
- Advanced materials and heat treatments
- Compact and efficient design
- 2-year warranty
- NEMA standard frame sizes
- Quick installation
- High reliability design

### Performance Specifications

		017VPX			023VPX			034VPX		
		T <sub>NOM</sub> (1)	T <sub>MAX ACCEL</sub>	T <sub>E-STOP</sub> (2)	T <sub>NOM</sub> (1)	T <sub>MAX ACCEL</sub>	T <sub>E-STOP</sub> (2)	T <sub>NOM</sub> (1)	T <sub>MAX ACCEL</sub>	T <sub>E-STOP</sub> (2)
Ratio		In-lbs (Nm)	In-lbs (Nm)	In-lbs (Nm)	In-lbs (Nm)	In-lbs (Nm)	In-lbs (Nm)	In-lbs (Nm)	In-lbs (Nm)	In-lbs (Nm)
1 STAGE	4:1	109 (12)	137 (16)	221 (25)	201 (23)	253 (29)	409 (46)	744 (84)	937 (106)	1515 (171)
	5:1	103 (12)	130 (15)	210 (24)	195 (22)	248 (28)	400 (45)	702 (80)	884 (100)	1429 (161)
	7:1	90 (10)	113 (13)	183 (21)	160 (18)	201 (23)	325 (37)	621 (70)	782 (88)	1264 (143)
	10:1	81 (9)	102 (12)	153 (17)	140 (16)	177 (20)	285 (32)	530 (60)	668 (76)	1080 (122)
2 STAGE	15:1	110 (12)	138 (16)	224 (25)	210 (24)	265 (30)	428 (48)	756 (85)	952 (108)	1539 (174)
	20:1	120 (14)	151 (17)	244 (28)	221 (25)	279 (32)	451 (51)	830 (94)	1046 (118)	1690 (191)
	25:1	113 (13)	142 (16)	230 (26)	216 (24)	272 (31)	440 (50)	778 (88)	980 (111)	1585 (179)
	28:1	121 (14)	153 (17)	248 (28)	225 (26)	284 (32)	459 (52)	845 (96)	1065 (120)	1721 (194)
	40:1	124 (14)	156 (18)	252 (29)	229 (26)	289 (33)	467 (53)	861 (97)	1085 (123)	1754 (198)
	50:1	117 (13)	147 (17)	237 (27)	223 (26)	281 (32)	454 (51)	806 (91)	1016 (115)	1642 (186)
	70:1	101 (11)	127 (14)	205 (23)	179 (20)	226 (26)	366 (41)	706 (80)	889 (100)	1437 (162)
	100:1	81 (9)	102 (12)	153 (17)	140 (16)	177 (20)	285 (32)	598 (68)	753 (85)	1217 (138)
Gearbox Weight		1 stage 0.8 lbs / 2 stage 1.1 lbs			1 stage 1.7 lbs / 2 stage 2.2 lbs			1 stage 5.0 lbs / 2 stage 6.0 lbs		
Input Speed		5000 RPM Maximum								
Backlash (arc-min)		12 (1 stage), 16 (2 stage)								
IP Rating		IP54								
Service Life		>10,000 HOURS								
Efficiency (3)		1 stage >90% / 2 stage >85%								
Operating Temperature		-40°F to +250°F								
Shaft Loads		See Tables on Page 12								

1. All torque ratings are based upon 3,000 RPM nominal input speed, and 10,000 hours minimum service life.

2. E-STOP torque rating is limited to 1,000 occurrences.

3. Efficiency rated at 3,000 RPM input speed, at Nominal Rated Torque.

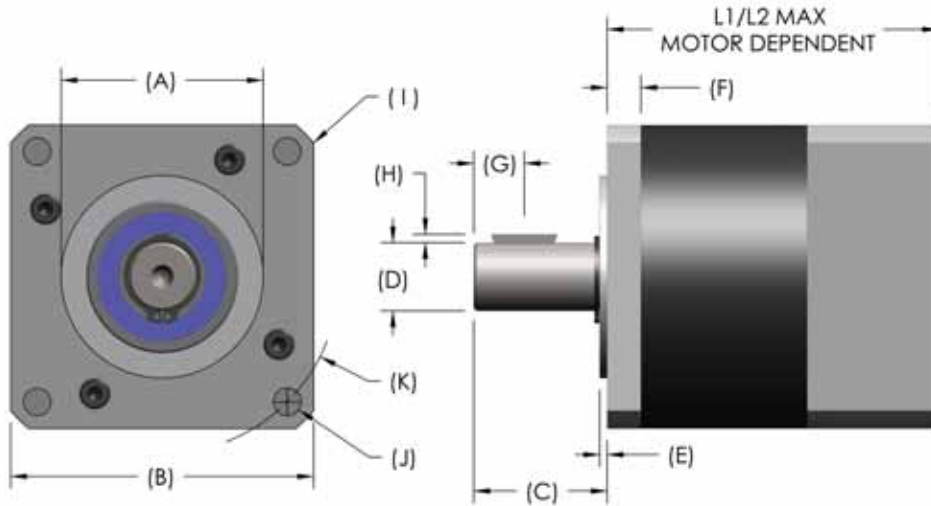

## Gearhead Dimensions

Dimension	Code	017VPX	023VPX	034VPX
		Inch (mm)	Inch (mm)	Inch (mm)
Pilot Diameter (+.000/-0.002 in)	A	0.866 (22)	1.500 (38.1)	2.875 (73)
Square Flange	B	1.70 (43.2)	2.25 (57.2)	3.45 (87.6)
Shaft Length	C	0.75 (19)	1.00 (25.4)	1.25 (31.8)
Shaft Diameter (+.0000/-0.0005 in)	D	0.500 (12.7)	0.500 (12.7)	0.750 (19)
Pilot Length	E	0.060 (1.5)	0.060 (1.5)	0.060 (1.5)
Flange Thickness	F	0.190 (4.8)	0.250 (6.4)	0.312 (7.9)
Key Location	G	0.28 (7.1)	0.38 (9.7)	0.50 (12.7)
Key Height	H	0.062 (1.6)	0.062 (1.6)	0.094 (2.4)
Woodruff Key Size		#404	#404	#606
Housing Diameter	I	2.25 (57)	3.00 (76.2)	4.63 (118)
Bolt Hole Diameter	J	0.125 (31.8)	0.205 (5.2)	0.220 (5.6)
Bolt Circle Diameter	K	1.725 (43.8)	2.625 (66.7)	3.875 (98.4)
Gearhead Length (1)	L1	2.41 (61.2)	2.46 (62.5)	3.33 (85)
	L2	2.96 (75.2)	3.14 (79.8)	4.26 (108)

## Moment of Inertia Table (2) (oz-in-sec<sup>2</sup>)

Ratio	017VPX	023VPX	034VPX
4:1	2.331E-04	1.322E-03	4.594E-03
5:1	1.895E-04	1.202E-03	3.544E-03
7:1	1.566E-04	1.110E-03	2.748E-03
10:1	1.395E-04	1.061E-03	2.332E-03
16:1	3.606E-04	1.755E-03	7.719E-03
20:1	1.896E-04	1.208E-03	3.611E-03
25:1	1.878E-04	1.203E-03	3.569E-03
28:1	1.566E-04	1.113E-03	2.782E-03
40:1	1.396E-04	1.062E-03	2.349E-03
50:1	1.391E-04	1.061E-03	2.338E-03
70:1	1.388E-04	1.060E-03	2.330E-03
100:1	1.386E-04	1.060E-03	2.326E-03

(1) Gearhead Length based on NEMA motor mounting.

(2) Gearhead inertia values shown include pinion, clamp and sleeve, and are for standard NEMA mounting.

• All specifications are subject to change without prior notice.



Quality at Every Turn

# Selection Guide

## Radial and Axial Output Shaft Loading Tables

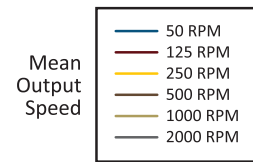

### PREDATOR

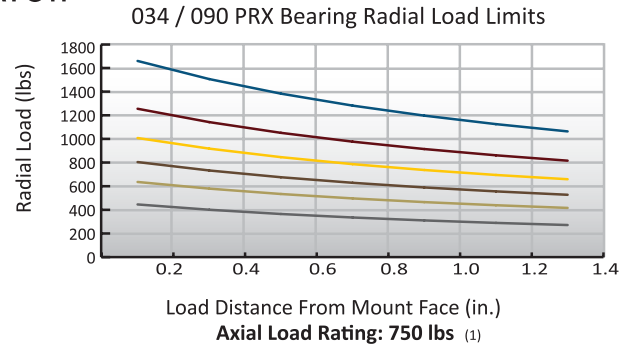
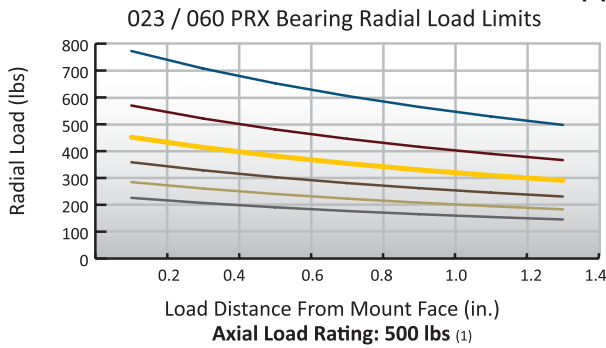

### RAPTOR

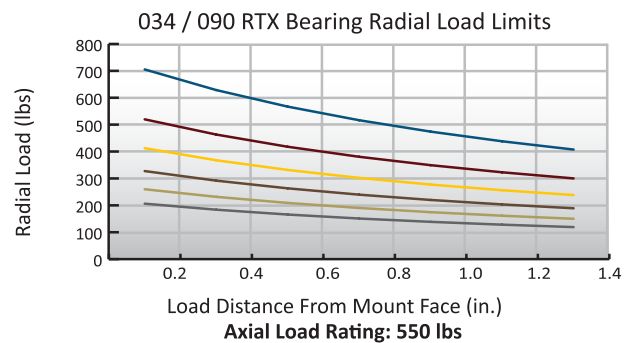
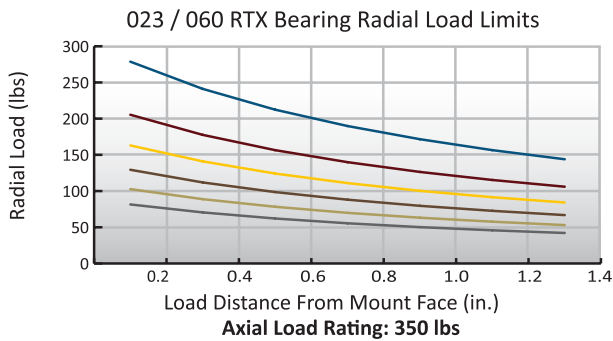

### RAPTOR EP

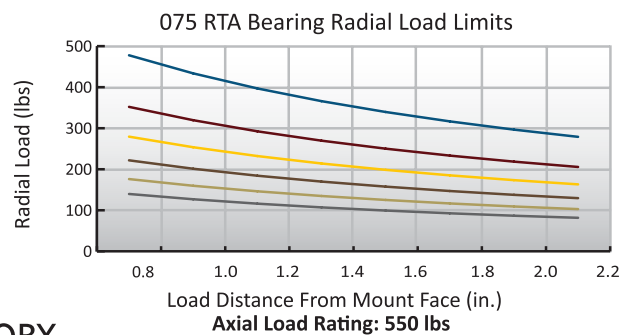
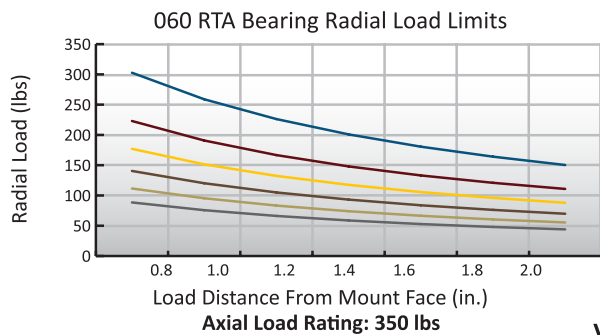

### VICTORY

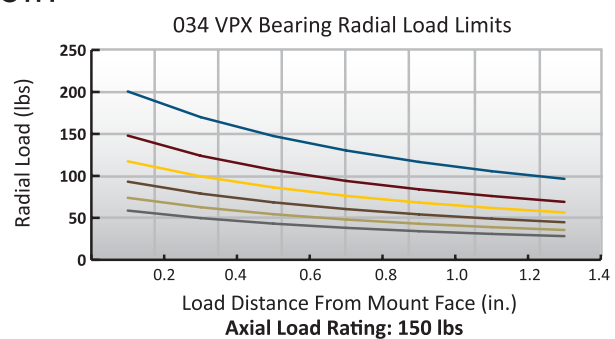
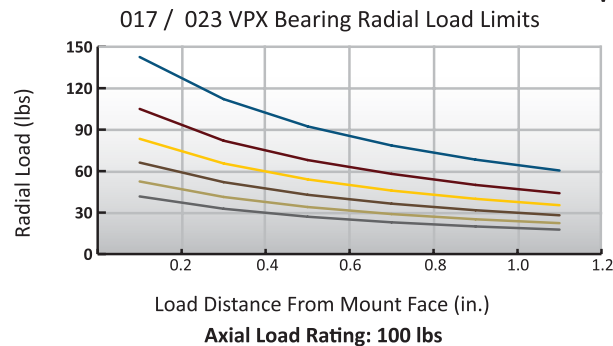

(1) Predator Axial load values shown are for loads into the gearbox face. For loads away from the face, reduce by 50%.

\* The above graphs display the allowable radial load (lbs) at a given distance (inches) from the Gearhead face based on an  $L_{10}$  bearing life of; 20,000 hours (PRX), 15,000 hours (RTX/RTA), 10,000 hours (VPX)

# CGI Product Selection Chart

## Step 1. Determine the Duty Cycle

$$\text{Duty Cycle} = \frac{(t_1 + t_2 + t_3)}{\text{(Cycle Time)}} * 100\%$$

$$t_1 + t_2 + t_3 + t_4 = \text{Cycle Time}$$

## Step 2. Is the Duty Cycle < 60% and the Cycle Time < 20 minutes?

If Yes, then use the Cyclic Operation steps A through C  
If No, then use the Continuous Operation steps D through E

### CYCLIC OPERATION

- A. Select the desired gearhead ratio
- B. Determine the Nominal Torque (TNOM)
  - $T_{NOM} = T_{MEAN} \times S_f$
  - $T_{MEAN}$  = Average Torque = Root Mean Cube of application torques. (see Formula no. 1)
  - $S_f$  = Speed Factor (see Table no. 1)
- C. Determine the Max Acceleration Torque (TMAX)
  - If the application TMAX is unknown, then use this formula to approximate:
  - $T_{MAX} = T_{MOTOR} \times \text{Ratio} \times C_f \times \text{Gearhead Efficiency}$
  - $T_{MOTOR}$  = Motor Peak Torque
  - Ratio = Reduction Ratio (from catalog)
  - $C_f$  = Cycle Factor (see Table no. 2)
  - Gearhead Efficiency (from catalog)

### CONTINUOUS OPERATION

- D. Select the desired gearhead ratio
- E. Determine the Nominal Torque (TNOM)
  - $T_{NOM} = T_{MEAN} \times S_f \times C_f$
  - $T_{MEAN}$  = Average Torque = Root Mean Cube of application torques. (see Formula no. 1)
  - $S_f$  = Speed Factor (see Table no. 1)
  - $C_f$  = Cycle Factor (see Table no. 2)

**Step 3. Determine E-STOP load requirements**  
(torque and inertia reflected on gearhead in case of emergency stop)

**Step 4. Evaluate speed requirement and determine if appropriate gearhead ratio has been selected**

**Step 5. Evaluate Radial and Axial load requirements and compare to catalog ratings**

**Step 6. Compare the above outputs**  
(TNOM, TMAX & TE-STOP) to the gearhead specifications and ratings to select a gearhead. If needed, choose the next size or configuration that meets your specifications

### FORMULA 1

$$T_{MEAN} = \sqrt[3]{\frac{(n1 * t1 * T1^3) + (n2 * t2 * T2^3) + (n3 * t3 * T3^3) + (n4 * t4 * T4^3)}{(n1 * t1) + (n2 * t2) + (n3 * t3) + (n4 * t4)}}$$

### FORMULA 2

$$RPM_{MEAN} = \frac{(n1 * t1) + (n2 * t2) + (n3 * t3)}{t1 + t2 + t3}$$

### SPEED PROFILE



### TORQUE PROFILE

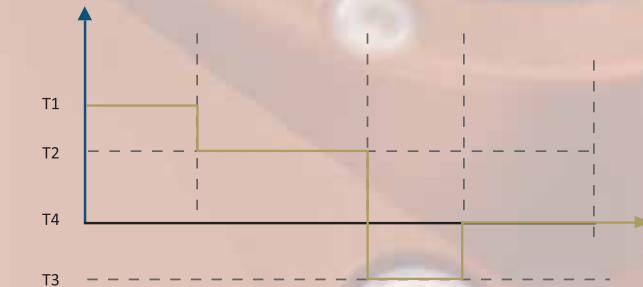

TABLE NO. 1

$S_f$ =	Input RPM (Mean) (Refer to Formula 2)
1.00	0 to 1000
1.15	1000 to 3000
1.30	3000 to 5000
1.50	> 5000

TABLE NO. 2

$C_f$ =	Cycles per Hour
1.00	0 to 1000
1.3	1000 to 2000
1.6	2000 to 3000
1.8	3000 to 5000
2.0	> 5000
2.0	Continuous

### DEFINITIONS

TNOM = Nominal Torque  
TMEAN = Average (RMC) Torque  
TMAX = Maximum Acceleration Torque  
TE-STOP = Emergency Stop Torque  
 $C_f$  = Cycle Factor  
 $S_f$  = Speed Factor  
TMOTOR = Motor Peak Torque

t1 = Acceleration Time  
t2 = Run Time  
t3 = Deceleration Time  
t4 = Dwell / Pause Time

n1 = Average Speed During t1  
n2 = Speed During t2  
n3 = Average Speed During t3  
n4 = Dwell Speed During t4

T1 = Torque During t1  
T2 = Torque During t2  
T3 = Torque During t3  
T4 = Torque During t4

# Selection Guide

## Application Data Sheet

Contact CGI, Inc. Sales Department  
toll free: 800.568.GEAR (4327)  
phone: 775.882.3422  
fax: 775.882.9599  
email: sales@cgimotion.com

### Contact Information

Company Name: \_\_\_\_\_  
Contact: \_\_\_\_\_  
Date: \_\_\_\_\_  
Address: \_\_\_\_\_  
City: \_\_\_\_\_ State: \_\_\_\_\_ Zip Code: \_\_\_\_\_  
Email: \_\_\_\_\_  
Phone: \_\_\_\_\_ Fax: \_\_\_\_\_  
Submitted by: \_\_\_\_\_

### Commercial Information

Project Name: \_\_\_\_\_ Estimated Annual Use: \_\_\_\_\_ Target Price : \_\_\_\_\_  
Application Description: \_\_\_\_\_  
Project Timing: \_\_\_\_\_  
Is this an existing application?  YES  NO Existing Model Data: \_\_\_\_\_

### Technical Data

Gearbox Type:  Inline  Right Angle Orientation:  Horizontal  Vertical  Shaft Up  Shaft Down  
Output Torque (in-lb): CONT \_\_\_\_\_ ACCEL \_\_\_\_\_ E-STOP \_\_\_\_\_  
Input Speed (RPM): \_\_\_\_\_ Output Speed (RPM): \_\_\_\_\_ Ratio: \_\_\_\_\_ Positioning Accuracy (Arc-Min): \_\_\_\_\_  
Rotation of Output:  Bi-Directional  Uni-Directional  
Motor Manufacturer: \_\_\_\_\_ Model: \_\_\_\_\_  
Rated Motor Speed (RPM): \_\_\_\_\_  
Motor Torque Rating (in-lbs): Continuous \_\_\_\_\_ Peak \_\_\_\_\_

### Axis Performance Data

Motion Profile (in seconds): Accel \_\_\_\_\_ Top Speed \_\_\_\_\_ Decel \_\_\_\_\_ At Rest \_\_\_\_\_  
Total Move Time: \_\_\_\_\_ Duty Cycle (% on): \_\_\_\_\_  Continuous  Intermittent  
Load Type:  Soft Ramp  Constant  Cyclic  Load Variable  Shock  Vibration  
What is mounted to the Output Shaft? \_\_\_\_\_ Is there overhung Load?  Yes  No  
Gearbox Max Length: \_\_\_\_\_ Gearbox Max Width : \_\_\_\_\_  
Output Radial Load (lbs): \_\_\_\_\_ Output Axial Load (lbs) : \_\_\_\_\_  
Weight Limit: \_\_\_\_\_ Environmental Requirements: \_\_\_\_\_

### Special Requirements

Describe Mechanical Special Requirements  
(Attach or send sketch if needed) \_\_\_\_\_  
Special Lube: \_\_\_\_\_ Materials: \_\_\_\_\_ Sealing: \_\_\_\_\_

## CGI Model Number Designations

Ordering Example: 023PRX0100-XX-23N08

023 PRX 0100 - XX - 23N08

**Frame Size**  
 017 (NEMA)  
 023 (NEMA)  
 034 (NEMA)  
 060 (METRIC)  
 075 (METRIC)  
 090 (METRIC)

**Model Type**  
 PRX Predator Planetary Gearhead  
 RTX Raptor Planetary Gearhead  
 RTA Raptor EP Planetary Gearhead  
 VPX Victory Planetary Gearhead

**Features**  
 XX (Standard Catalog)  
 VM (Vertical Mount VPX only)  
 KT (Adapter kit)  
 RK (Rear Bracket kit)

**Motor Code**  
 5-digit number (23N08)  
 Provide Motor Model Data  
 at order entry

**Project Code**  
 4-digit number followed by "X"  
 (example – 1234X)  
 Assigned by CGI Engineering

**Standard Ratio Designations**

0040 (4:1)	All Models
0050 (5:1)	All Models
0070 (7:1)	All Models
0100 (10:1)	All Models
0150 (15:1)	VPX only
0160 (16:1)	PRX, RTX, RTA
0200 (20:1)	All Models
0250 (25:1)	All Models
0280 (28:1)	All Models
0350 (35:1)	PRX, RTX, RTA
0400 (40:1)	All Models
0500 (50:1)	All Models
0700 (70:1)	All Models
1000 (100:1)	All Models
1600 (160:1)	RTX, RTA
2800 (280:1)	RTX, RTA
4000 (400:1)	RTX, RTA
5000 (500:1)	RTX, RTA
7000 (700:1)	RTX, RTA

Other ratios available



For more than 40 years, motion control and automation professionals have turned to CGI, Inc. for their precision gear solutions. Our engineering innovation and manufacturing expertise ensure robust solutions for even the most challenging precision gearing applications.

CGI, Inc. manufactures exclusively at our state-of-the-art headquarters in Carson City, Nevada, near beautiful Lake Tahoe. Our team of dedicated and experienced employees is focused on each customer's success by providing unparalleled solutions, service and support.



Quality at Every Turn

3400 Arrowhead Drive • Carson City, Nevada 89706 USA  
toll free: 800.568.GEAR (4327) • phone: 775.882.3422 • fax 775.882.9599  
[www.cgimotion.com](http://www.cgimotion.com)