

FAS Series FootActuate Air Switches

Features

- Long Life Air bulb actuator
- Remotely located air operated Electric Snap Switch
- Supplied with a 10 foot 1/8" ID PVC tubing connecting the foot pedal to the remote airswitch
- Remote switch equipped with a 9/16" U.N.F. bulkhead mount
- Isolating the electrically live snap switch from the floor
- Offers environmental protection from short or shock
- Ratings: 15A 1/2HP 125/250VAC or 20A 1HP/125VAC 2HP/250VAC

Dimensions:

FAS-1-15(15A)
FAS-1-20(20A)

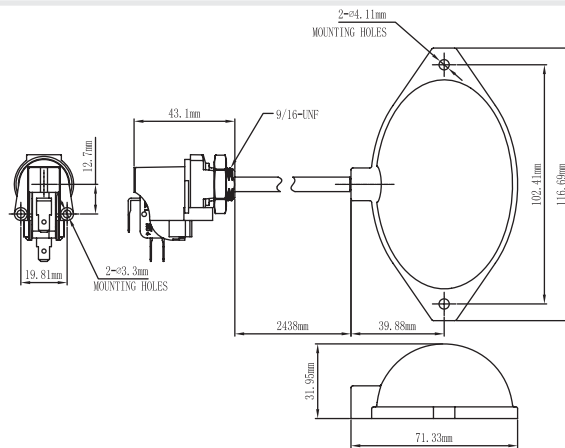

FAS-9-15(15A)
FAS-9-20(20A)

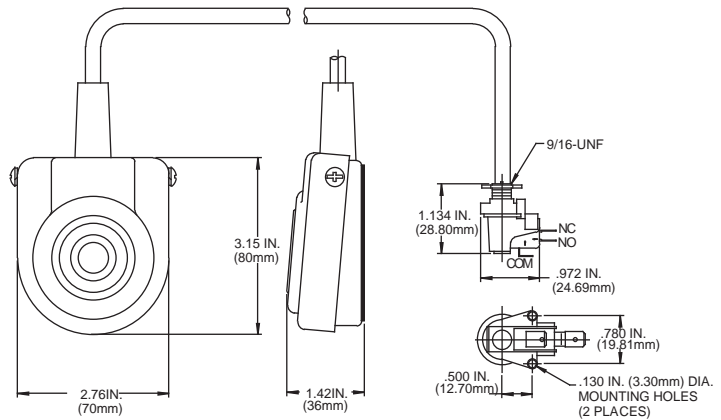

AS-15(15A)
AS-20(20A)

