

## GLOBAL STYLE LIMIT SWITCHES (METAL BODIED EN50047 TYPE)

SN4 SERIES (SINGLE CONDUIT ENTRY)

SN2 SERIES (TWO CONDUIT ENTRIES)



### Features

- Zn/Al die cast body
- Increased wiring space
- Earth grounding surface on same level as switching
- Easily interchangeable contact block
- Fine adjustment of switching point via adjusting screw
- Galvanically separated contacts
- Screw terminals with self-lifting clamps for easy wiring
- Positive Opening of NC contacts
- 4 x 90° actuator positions
- Cable entry available: M 20, PG13.5 and 1/2"NPT
- Conform to EN 50041 standard

### Specifications

Operating Speed	0.05mm-2m/sec
Operating Frequency	Mechanical: 120ops/min Electrical: 30 ops/min
Insulation Resistance	>100MΩ@500V DC
Contact Resistance	<25mΩ
Rated Current/Voltage	10A/600V AC (EN60947-5-1)
	UL/cUL Listed (E216958) AC15 A600 / DC13 Q300
Dielectric Strength	1000VAC for 1 min between current carrying parts 2500VAC for 1 min between non-current carrying parts
Service Life	Mechanically 1.0 x 10 <sup>7</sup> (operations) Electrically 5 x 10 <sup>5</sup> (operations)
Operating Temperature	-25~+80°C (-13~176°F)
Humidity	< 95%RH
Weight	400-450g
Degree of Protection	IP67

### Definitions of Operating Characteristics

- OF Operating Force
- RF Releasing Force
- OT Overtravel
- TT Total Travel
- PT Pretravel
- MD Movement Differential
- OP Operating Position
- PO Travel to Positive Opening



### Selection Guide:

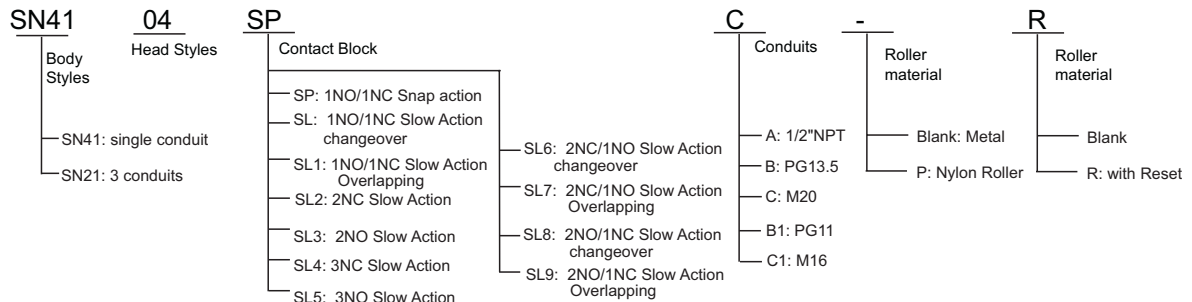

GLOBAL STYLE LIMIT SWITCHES (METAL BODIED EN50047 TYPE)



SN4 series  
(single conduit)

SN2 series  
(Three conduits)

Add suffix:  
A: for 1/2NPT  
B: for PG13.5  
C: for M20

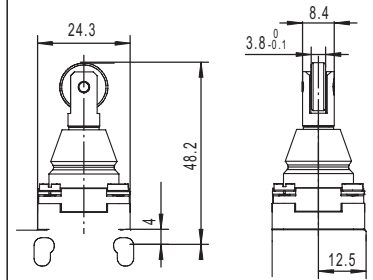
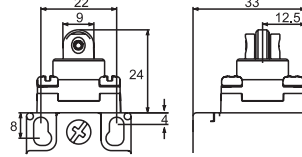
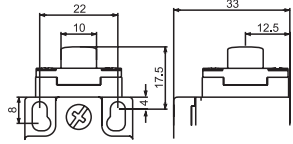

Contact block		Zb	SN4 series		SN2 series		SN2 series	
SP	⊕	snap action	SN4111-SP- SN2111-SP-	1NO+1NC	SN4112-SP- SN2112-SP-	1NO+1NC	SN4112-SP- SN2112-SP-	1NO+1NC
SL	⊕	slow action	SN4111-SL- SN2111-SL-	1NO+1NC BBM	SN4112-SL- SN2112-SL-	1NO+1NC BBM	SN4112-SL- SN2112-SL-	1NO+1NC BBM
SL1	⊕	slow action	SN4111-SL1- SN2111-SL1-	1NO+1NC MBB	SN4112-SL1- SN2112-SL1-	1NO+1NC MBB	SN4112-SL1- SN2112-SL1-	1NO+1NC MBB
SL2	⊕	slow action	SN4111-SL2- SN2111-SL2-	2NC	SN4112-SL2- SN2112-SL2-	2NC	SN4112-SL2- SN2112-SL2-	2NC
SL3		slow action	SN4111-SL3- SN2111-SL3-	2NO	SN4112-SL3- SN2112-SL3-	2NO	SN4112-SL3- SN2112-SL3-	2NO
SL4	⊕	slow action	SN4111-SL4- SN2111-SL4-	3NC	SN4112-SL4- SN2112-SL4-	3NC	SN4112-SL4- SN2112-SL4-	3NC
SL5		slow action	SN4111-SL5- SN2111-SL5-	3NO	SN4112-SL5- SN2112-SL5-	3NO	SN4112-SL5- SN2112-SL5-	3NO
SL6	⊕	slow action	SN4111-SL6- SN2111-SL6-	2NC+1NO BBM	SN4112-SL6- SN2112-SL6-	2NC+1NO BBM	SN4112-SL6- SN2112-SL6-	2NC+1NO BBM
SL7	⊕	slow action	SN4111-SL7- SN2111-SL7-	2NC+1NO MBB	SN4112-SL7- SN2112-SL7-	2NC+1NO MBB	SN4112-SL7- SN2112-SL7-	2NC+1NO MBB
SL8	⊕	slow action	SN4111-SL8- SN2111-SL8-	1NC+2NO BBM	SN4112-SL8- SN2112-SL8-	1NC+2NO BBM	SN4112-SL8- SN2112-SL8-	1NC+2NO BBM
SL9	⊕	slow action	SN4111-SL9- SN2111-SL9-	1NC+2NO MBB	SN4112-SL9- SN2112-SL9-	1NC+2NO MBB	SN4112-SL9- SN2112-SL9-	1NC+2NO MBB

SN4 series  
(single conduit)

SN2 series  
(Three conduits)

Add suffix:  
A: for 1/2NPT  
B: for PG13.5  
C: for M20

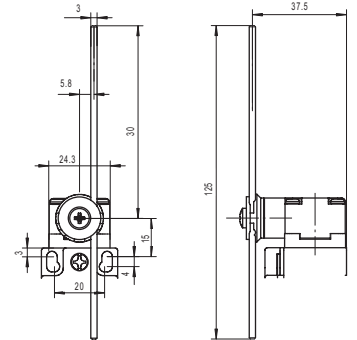
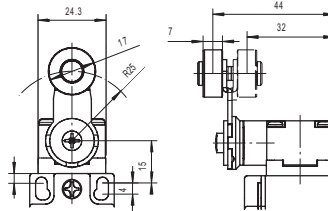
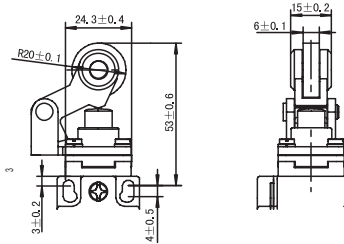

Contact block		Zb	SN4 series		SN2 series		SN2 series	
SP	⊕	snap action	SN4062-SP- SN2062-SP-	1NO+1NC	SN4104-SP- SN2104-SP-	1NO+1NC	SN4107-SP- SN2107-SP-	1NO+1NC
SL	⊕	slow action	SN4062-SL- SN2062-SL-	1NO+1NC BBM	SN4104-SL- SN2104-SL-	1NO+1NC BBM	SN4107-SL- SN2107-SL-	1NO+1NC BBM
SL1	⊕	slow action	SN4062-SL1- SN2062-SL1-	1NO+1NC MBB	SN4104-SL1- SN2104-SL1-	1NO+1NC MBB	SN4107-SL1- SN2107-SL1-	1NO+1NC MBB
SL2	⊕	slow action	SN4062-SL2- SN2062-SL2-	2NC	SN4104-SL2- SN2104-SL2-	2NC	SN4107-SL2- SN2107-SL2-	2NC
SL3		slow action	SN4062-SL3- SN2062-SL3-	2NO	SN4104-SL3- SN2104-SL3-	2NO	SN4107-SL3- SN2107-SL3-	2NO
SL4	⊕	slow action	SN4062-SL4- SN2062-SL4-	3NC	SN4104-SL4- SN2104-SL4-	3NC	SN4107-SL4- SN2107-SL4-	3NC
SL5		slow action	SN4062-SL5- SN2062-SL5-	3NO	SN4104-SL5- SN2104-SL5-	3NO	SN4107-SL5- SN2107-SL5-	3NO
SL6	⊕	slow action	SN4062-SL6- SN2062-SL6-	2NC+1NO BBM	SN4104-SL6- SN2104-SL6-	2NC+1NO BBM	SN4107-SL6- SN2107-SL6-	2NC+1NO BBM
SL7	⊕	slow action	SN4062-SL7- SN2062-SL7-	2NC+1NO MBB	SN4104-SL7- SN2104-SL7-	2NC+1NO MBB	SN4107-SL7- SN2107-SL7-	2NC+1NO MBB
SL8	⊕	slow action	SN4062-SL8- SN2062-SL8-	1NC+2NO BBM	SN4104-SL8- SN2104-SL8-	1NC+2NO BBM	SN4107-SL8- SN2107-SL8-	1NC+2NO BBM
SL9	⊕	slow action	SN4062-SL9- SN2062-SL9-	1NC+2NO MBB	SN4104-SL9- SN2104-SL9-	1NC+2NO MBB	SN4107-SL9- SN2107-SL9-	1NC+2NO MBB

GLOBAL STYLE LIMIT SWITCHES (METAL BODIED EN50047 TYPE)



SN4 series  
(single conduit)

SN2 series  
(Three conduits)

Add suffix:  
A: for 1/2NPT  
B: for PG13.5  
C: for M20

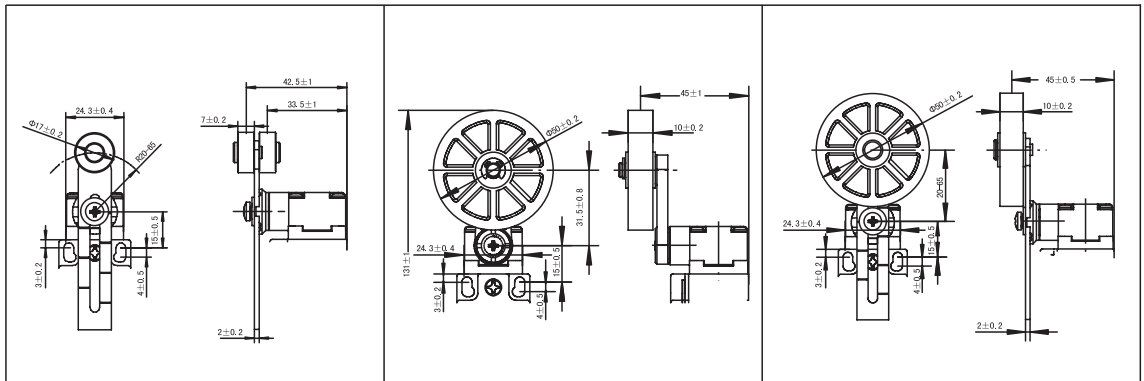

Contact block Zb

SP	⊕	snap action	SN4108-SP- SN2108-SP- _	1NO+1NC	SN4114-SP- SN2114-SP- _	1NO+1NC	SN4118-SP- SN2118-SP- _	1NO+1NC
SL	⊕	slow action	SN4108-SL- SN2108-SL- _	1NO+1NC BBM	SN4114-SL- SN2114-SL- _	1NO+1NC BBM	SN4118-SL- SN2118-SL- _	1NO+1NC BBM
SL1	⊕	slow action	SN4108-SL1- SN2108-SL1- _	1NO+1NC MBB	SN4114-SL1- SN2114-SL1- _	1NO+1NC MBB	SN4118-SL1- SN2118-SL1- _	1NO+1NC MBB
SL2	⊕	slow action	SN4108-SL2- SN2108-SL2- _	2NC	SN4114-SL2- SN2114-SL2- _	2NC	SN4118-SL2- SN2118-SL2- _	2NC
SL3		slow action	SN4108-SL3- SN2108-SL3- _	2NO	SN4114-SL3- SN2114-SL3- _	2NO	SN4118-SL3- SN2118-SL3- _	2NO
SL4	⊕	slow action	SN4108-SL4- SN2108-SL4- _	3NC	SN4114-SL4- SN2114-SL4- _	3NC	SN4118-SL4- SN2118-SL4- _	3NC
SL5		slow action	SN4108-SL5- SN2108-SL5- _	3NO	SN4114-SL5- SN2114-SL5- _	3NO	SN4118-SL5- SN2118-SL5- _	3NO
SL6	⊕	slow action	SN4108-SL6- SN2108-SL6- _	2NC+1NO BBM	SN4114-SL6- SN2114-SL6- _	2NC+1NO BBM	SN4118-SL6- SN2118-SL6- _	2NC+1NO BBM
SL7	⊕	slow action	SN4108-SL7- SN2108-SL7- _	2NC+1NO MBB	SN4114-SL7- SN2114-SL7- _	2NC+1NO MBB	SN4118-SL7- SN2118-SL7- _	2NC+1NO MBB
SL8	⊕	slow action	SN4108-SL8- SN2108-SL8- _	1NC+2NO BBM	SN4114-SL8- SN2114-SL8- _	1NC+2NO BBM	SN4118-SL8- SN2118-SL8- _	1NC+2NO BBM
SL9	⊕	slow action	SN4108-SL9- SN2108-SL9- _	1NC+2NO MBB	SN4114-SL9- SN2114-SL9- _	1NC+2NO MBB	SN4118-SL9- SN2118-SL9- _	1NC+2NO MBB

SN4 series  
(single conduit)

SN2 series  
(Three conduits)

Add suffix:  
A: for 1/2NPT  
B: for PG13.5  
C: for M20

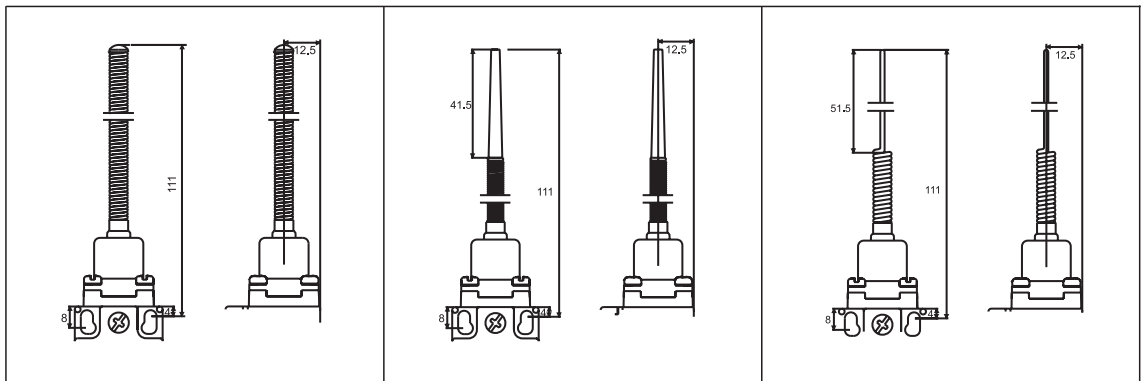

Contact block Zb

SP	⊕	snap action	SN4100-SP- SN4100-SP- _	1NO+1NC	SN4166-SP- SN4166-SP- _	1NO+1NC	SN4169-SP- SN4169-SP- _	1NO+1NC
----	---	-------------	-------------------------------	---------	-------------------------------	---------	-------------------------------	---------

Body Dimension:

SN4:

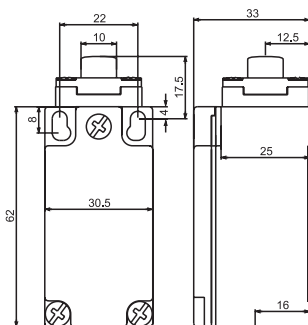

SN2:

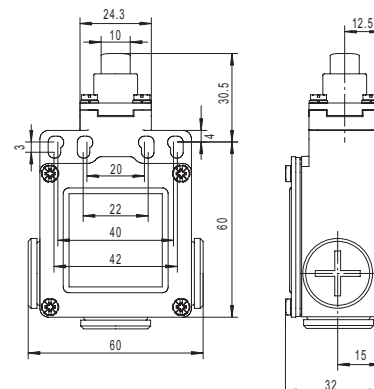

**GLOBAL STYLE LIMIT SWITCHES (METAL BODIED EN50047 TYPE)  
WITH RESET FUNCTION**



SN4-R SERIES (SINGLE CONDUIT ENTRY, WITH RESET)

SN2-R SERIES (TWO CONDUIT ENTRIES)



SN4 series  
(single conduit)

SN2 series  
(Three conduits)

Add suffix:  
A: for 1/2NPT  
B: for PG13.5  
C: for M20

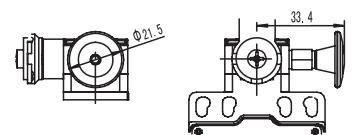
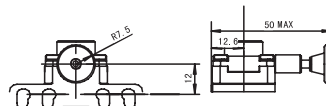
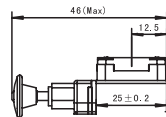

Contact block Zb

SP		snap action	SN41xx-SP-_-R	1NO+1NC	SN21xx-SP-_-R	1NO+1NC	SN41xx-SP-_-R SN21xx-SP-_-R	1NO+1NC
SL		slow action	SN41xx-SL-_-R	1NO+1NCBBM	SN21xx-SL-_-R	1NO+1NCBBM	SN41xx-SL-_-R SN21xx-SL-_-R	1NO+1NC BBM
SL1		slow action	SN41xx-SL1-_-R	1NO+1NCMBB	SN21xx-SL1-_-R	1NO+1NCMBB	SN41xx-SL1-_-R SN21xx-SL1-_-R	1NO+1NC MBB
SL2		slow action	SN41xx-SL2-_-R	2NC	SN21xx-SL2-_-R	2NC	SN41xx-SL2-_-R SN21xx-SL2-_-R	2NC
SL3		slow action	SN41xx-SL3-_-R	2NO	SN21xx-SL3-_-R	2NO	SN41xx-SL3-_-R SN21xx-SL3-_-R	2NO
SL4		slow action	SN41xx-SL4-_-R	3NC	SN21xx-SL4-_-R	3NC	SN41xx-SL4-_-R SN21xx-SL4-_-R	3NC
SL5		slow action	SN41xx-SL5-_-R	3NO	SN21xx-SL5-_-R	3NO	SN41xx-SL5-_-R SN21xx-SL5-_-R	3NO
SL6		slow action	SN41xx-SL6-_-R	2NC+1NOBBM	SN21xx-SL6-_-R	2NC+1NOBBM	SN41xx-SL6-_-R SN21xx-SL6-_-R	2NC+1NO BBM
SL7		slow action	SN41xx-SL7-_-R	2NC+1NOMBB	SN21xx-SL7-_-R	2NC+1NOMBB	SN41xx-SL7-_-R SN21xx-SL7-_-R	2NC+1NO MBB
SL8		slow action	SN41xx-SL8-_-R	1NC+2NOBBM	SN21xx-SL8-_-R	1NC+2NOBBM	SN41xx-SL8-_-R SN21xx-SL8-_-R	1NC+2NO BBM
SL9		slow action	SN41xx-SL9-_-R	1NC+2NOMBB	SN21xx-SL9-_-R	1NC+2NOMBB	SN41xx-SL9-_-R SN21xx-SL9-_-R	1NC+2NO MBB

For 11, 12, 31, 32, 62, 63, 72,73  
00, 66, 69 styles

For 11, 12, 31, 32, 62, 63, 72,73  
00, 66, 69 styles

For 04, 07, 08, 14, 18 styles