

## Simple and Reliable: The manual Clamping Element HK.

The HK series is a manually operated clamping element. By rotating the freely adjustable clamp lever, the contact sections are pressed synchronously against the free surfaces of the section rail guide.

The floating contact sections guarantee symmetric power transmission.

## HK Design

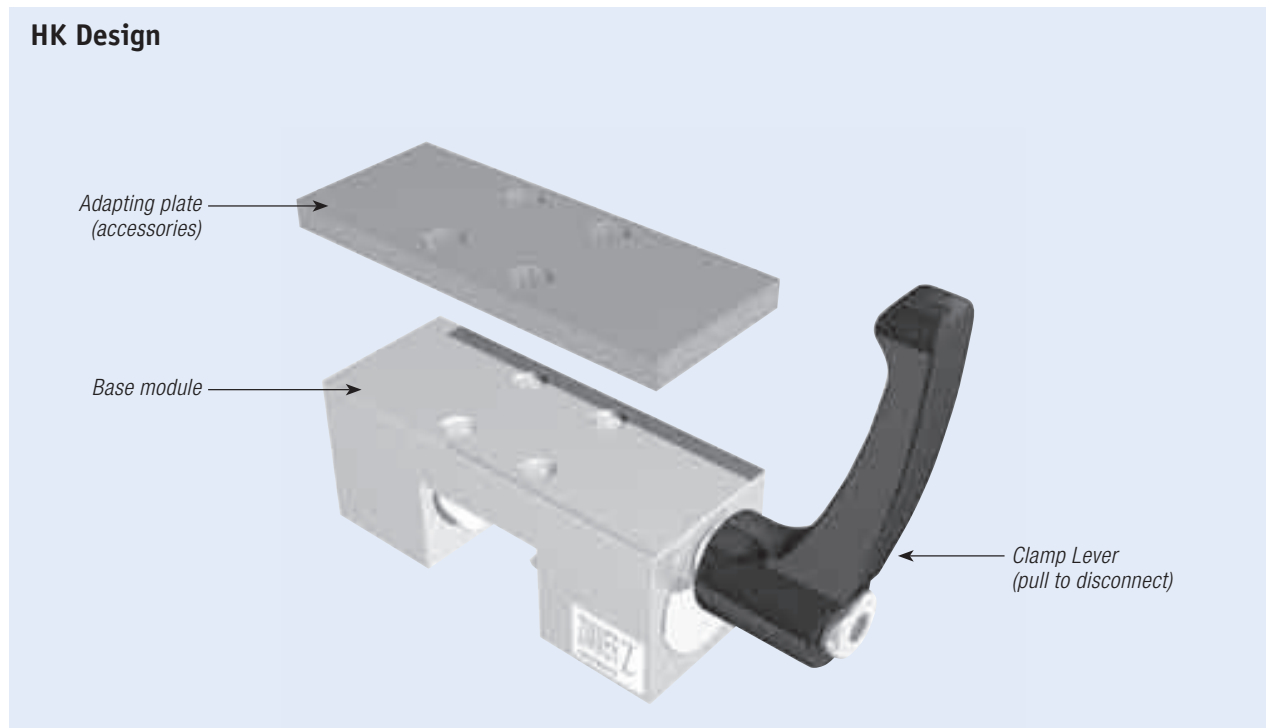

### Special characteristics:

- Simple and safe construction
- Floating supported contact sections
- Exact positioning
- Holding power up to 2,000 N

### Application scenarios for HK:

- Table traverses and carriages
- Adjustment of width and stops
- Positioning of optic instruments and measuring tables

### Variations:

Depending on the height of the carriage, an additional adapting plate must be ordered (see table).

### Operation:

Standard with hand lever. Other operation options available on request, e.g. a DIN 912 screw.

Rail manufacturer



Type of rail	Size	Type of carriage	Item number	Adapting plate <sup>*1</sup> (for height compensation)	Measure D [mm]	Measure table (page 112 and 113) <sup>*2</sup>
SR/SSR	15	SR..TB, SR..SB, SR..W, SR..V, SSR..XWY, SSR..XVY, SSR..XTBY	HK 1501 A		24	3
	20	SR..TB, SR..SB, SR..W, SR..V, SSR..XW, SSR..XV, SSR..XTB	HK 2001 A		28	8
	25	SR..TB, SR..SB, SR..W, SR..V, SSR..XWY, SSR..XVY, SSR..XTBY	HK 2501 A		33	17
	30	SR..TB, SR..SB, SR..W, SR..V, SSR..XW	HK 3001 A		42	28
	35	SR..TB, SR..SB, SR..W, SR..V, SSR..XW	HK 3501 A	PMK 35-4	48	31
	45	SR..TB, SR..W	HK 4501 A		60	43
	55	SR..TB, SR..W	HK 5501 S		68	48
HSR	15	HSR..A, HSR..B	HK 1501 A		24	3
		HSR..R	HK 1501 A	PHK 15-4	28	
	20	HSR..A, HSR..LA, HSR..B, HSR..LB, HSR..R, HSR..LR, HSR..CA, HSR..HA, HSR..CB, HSR..HB	HK 2001 A		30	11
		HSR..R, HSR..LR	HK 2501 A	PHK 25-4	40	21
	25	HSR..A, HSR..LA, HSR..B, HSR..LB, HSR..CA, HSR..HA, HSR..CB, HSR..HB	HK 2501 A		36	21
		HSR..R, HSR..LR	HK 2501 A	PHK 25-4	40	
	30	HSR..A, HSR..LA, HSR..B, HSR..LB, HSR..CA, HSR..HA, HSR..CB, HSR..HB	HK 3001 A		42	28
		HSR..R, HSR..LR	HK 3001 A	PHK 30-3	45	
	35	HSR..A, HSR..LA, HSR..B, HSR..LB, HSR..CA, HSR..HA, HSR..CB, HSR..HB	HK 3501 A		48	35
		HSR..R, HSR..LR	HK 3501 A	PMK 35-7	55	
	45	HSR..A, HSR..LA, HSR..B, HSR..LB, HSR..CA, HSR..HA, HSR..CB, HSR..HB	HK 4501 A		60	43
		HSR..R, HSR..LR	HK 4501 A	PHK 45-10	70	
	55	HSR..A, HSR..LA, HSR..B, HSR..LB, HSR..CA, HSR..HA, HSR..CB, HSR..HB	HK 5501 A		70	62
HSR..R, HSR..LR		HK 5501 A	PHK 55-10	80		
65	HSR..A, HSR..LA, HSR..B, HSR..LB, HSR..R, HSR..LR, HSR..CA, HSR..HA, HSR..CB, HSR..HB	HK 6501 A		90	53	
GSR	15	GSR..T, GSR..V	HK 1501 G		20	58
	20	GSR..T, GSR..V	HK 2001 G		24	59
	25	GSR..T, GSR..V	HK 2501 G		30	60
	30	GSR..T	HK 3001 G		33	57
	35	GSR..T	HK 3501 G		38	61
HRW	17	HRW..CA, HRW..CR	HK 1701 B		17	39
	21	HRW..CA, HRW..CR	HK 2101 B		21	23
	27	HRW..CA, HRW..CR	HK 2701 B		27	24
	35	HRW..CA, HRW..CR	HK 3501 B		35	45
	50	HRW..CA, HRW..CR	HK 5001 B		50	50
	60	HRW..CA	Ⓢ		60	
SHW	17	SHW..CAM, SHW..CRM	HK 1701 B		17	39
	21	SHW..CA, SHW..CR	HK 2101 B		21	23
	27	SHW..CA, SHW..CR	HK 2701 B		27	24
	35	SHW..CA, SHW..CR	HK 3501 B		35	45
	50	SHW..CA, SHW..CR	HK 5001 B		50	50
	60	SHW..CA	Ⓢ		60	
SNR/SNS	25	SNR..R, SNR..LR, SNR..C, SNR..LC, SNS..R, SNS..LR, SNS..C, SNS..LC	HK 2501 N		31	13
		SNR..R, SNR..LR, SNR..C, SNR..LC, SNS..R, SNS..LR, SNS..C, SNS..LC	HK 3001 A		38	25
	35	SNR..R, SNR..LR, SNR..C, SNR..LC, SNS..R, SNS..LR, SNS..C, SNS..LC	HK 3501 A		44	31
		SNR..CH, SNR..LCH, SNS..CH, SNS..LCH	Ⓢ		48	
		SNR..RH, SNR..LRH, SNS..RH, SNS..LRH	Ⓢ		55	
	45	SNR..R, SNR..LR, SNR..C, SNR..LC, SNS..R, SNS..LR, SNS..C, SNS..LC	HK 4501 A		52	40
		SNR..RH, SNR..LRH, SNS..RH, SNS..LRH, SNR..CH, SNR..LCH, SNS..CH, SNS..LCH	Ⓢ		60	
	55	SNR..R, SNR..LR, SNR..C, SNR..LC, SNS..R, SNS..LR, SNS..C, SNS..LC	HK 5501 A		63	46
		SNR..CH, SNR..LCH, SNS..CH, SNS..LCH	Ⓢ		70	
		SNR..RH, SNR..LRH, SNS..RH, SNS..LRH	Ⓢ		80	
	65	SNR..R, SNR..LR, SNR..C, SNR..LC, SNS..R, SNS..LR, SNS..C, SNS..LC	HK 6501 N		75	52

<sup>\*1</sup> Only required for high carriage design

<sup>\*2</sup> Supplements the measure table and datasheet

See page 12 for part number explanation

Type of rail	Size	Type of carriage	Item number	Adapting plate <sup>*1</sup> (for height compensation)	Measure D [mm]	Measure table (page 112 and 113)	
NR / NRS	25	NR / NRS..XR, NR / NRS..XLR, NR / NRS..XA, NR / NRS..XLA, NR / NRS..XB, NR / NRS..XLB	HK 2501 N		31	13	
	30	NR / NRS..R, NR / NRS..LR, NR / NRS..A, NR / NRS..LA, NR / NRS..B, NR / NRS..LB	HK 3001 A		38	25	
	35	NR / NRS..R, NR / NRS..LR, NR / NRS..A, NR / NRS..LA, NR / NRS..B, NR / NRS..LB	HK 3501 A		44	31	
	45	NR / NRS..R, NR / NRS..LR, NR / NRS..A, NR / NRS..LA, NR / NRS..B, NR / NRS..LB	HK 4501 A		52	40	
	55	NR / NRS..R, NR / NRS..LR, NR / NRS..A, NR / NRS..LA, NR / NRS..B, NR / NRS..LB	HK 5501 A		63	46	
	65	NR / NRS..R, NR / NRS..LR, NR / NRS..A, NR / NRS..LA, NR / NRS..B, NR / NRS..LB	HK 6501 N		75	52	
SHS	15	SHS..C, SHS..LC, SHS..V, SHS..LV SHS..R	HK 1501 A HK 1501 A	PHK 15-2 PHK 15-6	24 28	1	
	20	SHS..C, SHS..LC, SHS..V, SHS..LV	HK 2001 A	PHK 20-2	30	8	
	25	SHS..C, SHS..LC, SHS..V, SHS..LV SHS..R, SHS..LR	HK 2501 A HK 2501 A	PHK 25-2 PHK 25-6	36 40	19	
	30	SHS..C, SHS..LC, SHS..V, SHS..LV SHS..R, SHS..LR	HK 3001 A HK 3001 A		42 45	28	
	35	SHS..C, SHS..LC, SHS..V, SHS..LV SHS..R, SHS..LR	HK 3501 A HK 3501 A	PMK 35-4 PMK 35-11	48 55	31	
	45	SHS..C, SHS..LC, SHS..V, SHS..LV SHS..R, SHS..LR	HK 4501 A HK 4501 A		60 70	43	
	55	SHS..C, SHS..LC, SHS..V, SHS..LV SHS..R, SHS..LR	HK 5501 A HK 5501 A		70 80	62	
	65	SHS..C, SHS..LC, SHS..V, SHS..LV	HK 6501 A	PHK 55-10	90	53	
	SRG	15	SRG..A, SRG..V	⊗		24	
		20	SRG..A, SRG..LA, SRG..V, SRG..LV	⊗		30	
		25	SRG..A, SRG..V SRG..A, SRG..LA, SRG..V, SRG..LV	HK 2501 E HK 2501 E		36 40	20
		30	SRG..C, SRG..LC SRG..R, SRG..LR	HK 3001 E HK 3001 E		42 45	27
35		SRG..C, SRG..LC SRG..R, SRG..LR	HK 3501 E HK 3501 E		48 55	33	
45		SRG..C, SRG..LC SRG..R, SRG..LR	HK 4501 E HK 4501 E		60 70	42	
55		SRG..C, SRG..LC SRG..R, SRG..LR	HK 5501 E HK 5501 E		70 80	47	
65		SRG..LC, SRG..LV	HK 6501 E		90	51	
HCR		15	HCR 15A +60/150R HCR 15A +60/300R HCR 15A +60/400R	HK 1501/150 HK 1501/300 HK 1501/400		24	3
		25	HCR 25A +60/500R HCR 25A +60/750R HCR 25A +60/1000R HCR 25A +60/1600R	HK 2501/500 HK 2501/750 HK 2501/1000 HK 2501/1600		36	21
	35	HCR 35A +60/600R HCR 35A +60/800R HCR 35A +60/1000R HCR 35A +60/1300R	HK 3501/600 HK 3501/800 HK 3501/1000 HK 3501/1300		48	35	
	45	HCR 45A +60/800R HCR 45A +60/1000R HCR 45A +60/1200R HCR 45A +60/1600R	⊗ ⊗ ⊗ ⊗				
	65	HCR 65A +60/1000R HCR 65A +60/1500R HCR 65A +45/2000R HCR 65A +45/2500R HCR 65A +30/3000R	⊗ ⊗ ⊗ ⊗ ⊗				

Rail manufacturer



<sup>\*1</sup> Only required for high carriage design  
<sup>\*2</sup> Supplements the measure table and datasheet

See page 12 for part number explanation

HK

Rail manufacturer  
**Rexroth**  
 Bosch Group

Type of rail	Size	Type of carriage	Item number	Adapting plate <sup>*1</sup> (for height compensation)	Measure D [mm]	Measure table <sup>*2</sup> (page 112 and 113)
1605, 1607, 1645, 1647	15	1622, 1623, 1631, 1632, 1651, 1653, 1661, 1662, 1665, 1666	HK 1505 KR		24	2
		1621	HK 1505 KR	PHK 15-4	28	
		1661, 1662, 1665, 1651, 1653, 1666, 1622, 1623	HK 2005 KR		30	10
	25	1661, 1662, 1665, 1651, 1653, 1666, 1622, 1623, 1631, 1632	HK 2505 KR		36	20
		1621, 1624	HK 2505 KR	PHK 25-4	40	
	30	1661, 1662, 1665, 1651, 1653, 1666, 1622, 1623, 1631, 1632	HK 3005 KR		42	27
		1621, 1624	HK 3005 KR	PHK 30-3	45	
	35	1661, 1662, 1665, 1651, 1653, 1666, 1622, 1623, 1631, 1632	HK 3505 KR		48	33
		1621, 1624	HK 3505 KR	PMK 35-7	55	
		1651, 1653, 1622, 1623	HK 4505 KR		60	42
	45	1621, 1624	HK 4505 KR	PHK 45-10	70	
		1651, 1653, 1622, 1623	HK 5505 KR		70	47
	55	1621, 1624	HK 5505 KR	PHK 55-10	80	
		1651, 1653, 1622, 1623,	HK 6505 KR		90	51
	1675, 1677	20	1671	HK 2005 KB		27
25		1671	HK 2505 KB		35	38
35		1671	HK 3505 KB		50	50
1805, 1807	25	1851, 1853	HK 2505 KR		36	20
		1821, 1824	HK 2505 KR	PHK 25-4	40	
	35	1851, 1853	HK 3505 KR		48	33
		1821, 1824	HK 3505 KR	PMK 35-7	55	
	45	1851, 1853	HK 4505 KR		60	42
		1821, 1824	HK 4505 KR	PHK 45-10	70	
	55	1851, 1853	HK 5505 KR		70	47
		1821, 1824	HK 5505 KR	PHK 55-10	80	
65	1853, 1824	HK 6505 KR		90	51	
R2035 R2037	15	R2031, R2032	HK 1505 F		24	54
		R2041, R2042				
	20	R2031, R2032	HK 2005 F		30	55
		R2041, R2042				
	25	R2031, R2032 R2041, R2042	HK 2505 F		36	56

Rail manufacturer



MR	25	MR..A, MR..B	HK 2503 MR		36	20
		MR..C, MR..D, MR..E	HK 2503 MR	PHK 25-4	40	
	35	MR..A, MR..B	HK 3503 MR		48	33
		MR..C, MR..D, MR..E	HK 3503 MR	PMK 35-7	55	
	45	MR..A, MR..B	HK 4503 MR		60	42
		MR..C, MR..D	HK 4503 MR	PHK 45-10	70	
	55	MR..A, MR..B	HK 5503 MR		70	47
		MR..C, MR..D	HK 5503 MR	PHK 55-10	80	
65	MR..B, MR..D	HK 6503 MR		90	51	
BM	15	BM..A, BM..F, BM..K	HK 1503 BM		24	2
		BM..C	HK 1503 BM	PHK 15-4	28	
	20	BM..A, BM..B, BM..C, BM..D, BM..F, BM..G, BM..K	HK 2003 BM		30	10
	25	BM..A, BM..B, BM..F, BM..G	HK 2503 BM		36	20
		BM..C, BM..D, BM..E	HK 2503 BM	PHK 25-4	40	
	30	BM..A, BM..B, BM..F, BM..G	HK 3003 BM		42	27
		BM..C, BM..D, BM..E	HK 3003 BM	PHK 30-3	45	
	35	BM..A, BM..B, BM..F, BM..G	HK 3503 BM		48	33
		BM..C, BM..D, BM..E	HK 3503 BM	PMK 35-7	55	
	45	BM..A, BM..B	HK 4503 BM		60	42
		BM..C, BM..D	HK 4503 BM	PHK 45-10	70	

<sup>\*1</sup> Only required for high carriage design

<sup>\*2</sup> Supplements the measure table and datasheet

See page 12 for part number explanation

Type of rail	Size	Type of carriage	Item number	Adapting plate <sup>*1</sup> (for height compensation)	Measure D [mm] <sup>*2</sup>	Measure table (page 112 and 113)
LWH	15	LWH..B, LWH..SL, LWH..M, LWHT..B, LWHT..SL, LWHT..M	HK 1501 A		24	3
		LWHS..B, LWHS..SL, LWHS..M LWHD..B, LWHD..M, LWHY	HK 1501 A	PHK 15-4	28	
	20	LWH..B, LWH..SL, LWH..M, LWHG, LWHT..B, LWHT..SL, LWHT..M, LWHTG, LWHS..B, LWHS..SL, LWHS..M, LWHS, LWHY	HK 2001 A		30	11
		LWH..B, LWH..SL, LWH..M, LWHG, LWHT..B, LWHT..SL, LWHT..M, LWHTG, LWHS..B, LWHS..SL, LWHS..M, LWHS, LWHD..B, LWHD..M, LWHDG, LWHY	HK 2501 A		36	
	25	LWH..B, LWH..SL, LWH..M, LWHG, LWHT..B, LWHT..SL, LWHT..M, LWHTG, LWHS..B, LWHS..SL, LWHS..M, LWHS, LWHD..B, LWHD..M, LWHDG, LWHY	HK 2501 A	PHK 25-4	40	21
		LWH..B, LWH..SL, LWH..M, LWHG, LWHT..B, LWHT..SL, LWHT..M, LWHTG, LWHS..B, LWHS..SL, LWHS..M, LWHS, LWHD..B, LWHD..M, LWHDG, LWHY	HK 3001 A		42	
	30	LWH..B, LWH..SL, LWH..M, LWHG, LWHT..B, LWHT..SL, LWHT..M, LWHTG, LWHS..B, LWHS..SL, LWHS..M, LWHS, LWHD..B, LWHD..M, LWHDG, LWHY	HK 3001 A	PHK 30-3	45	28
		LWH..B, LWH..M, LWHG, LWHT..B, LWHT..M, LWHTG LWHD..B, LWHD..M, LWHDG, LWHY	HK 3501 A		48	
	35	LWH..B, LWH..M, LWHG, LWHT..B, LWHT..M, LWHTG LWHD..B, LWHD..M, LWHDG, LWHY	HK 3501 A	PMK 35-7	55	35
		LWH..B, LWH..M, LWHG, LWHT..B, LWHT..M, LWHTG LWHD..B, LWHD..M, LWHDG, LWHY	HK 4501 A		60	
45	LWH..B, LWH..M, LWHG, LWHT..B, LWHT..M, LWHTG LWHD..B, LWHD..M, LWHDG, LWHY	HK 4501 A	PHK 45-10	70	43	
	LWH..B, LWHG, LWHT..B, LWHTG LWHD..B, LWHDG, LWHY	HK 5501 A		70		
55	LWH..B, LWHG, LWHT..B, LWHTG LWHD..B, LWHDG, LWHY	HK 5501 A	PHK 55-10	80	62	
	LWH..B, LWHG, LWHT..B, LWHTG LWHD..B, LWHDG, LWHY	HK 6501 A		90		
65	LWH..B, LWHG, LWHT..B, LWHTG, LWHD..B, LWHDG, LWHY	HK 6501 A		90	53	
	LWH..B, LWHG, LWHT..B, LWHTG, LWHD..B, LWHDG, LWHY	HK 6501 A		90		
LWE	15	LWE..Q, LWET..Q, LWES..Q, LWEC, LWEC..SL, LWE, LWE..SL, LWEG, LWEG..SL, LWETC, LWETC..SL, LWET, LWET..SL; LWETG, LWETG..SL, LWESC, LWESC..SL, LWES, LWES..SL, LWESG, LWESG..SL	HK 1501 A		24	3
		LWE..Q, LWET..Q, LWES..Q, LWEC, LWEC..SL, LWE, LWE..SL, LWEG, LWEG..SL, LWETC, LWETC..SL, LWET, LWET..SL; LWETG, LWETG..SL, LWESC, LWESC..SL, LWES, LWES..SL, LWESG, LWESG..SL	HK 2001 A		28	
	20	LWE..Q, LWET..Q, LWES..Q, LWEC, LWEC..SL, LWE, LWE..SL, LWEG, LWEG..SL, LWETC, LWETC..SL, LWET, LWET..SL; LWETG, LWETG..SL, LWESC, LWESC..SL, LWES, LWES..SL, LWESG, LWESG..SL	HK 2001 A		28	8
		LWE..Q, LWET..Q, LWES..Q, LWEC, LWEC..SL, LWE, LWE..SL, LWEG, LWEG..SL, LWETC, LWETC..SL, LWET, LWET..SL; LWETG, LWETG..SL, LWESC, LWESC..SL, LWES, LWES..SL, LWESG, LWESG..SL	HK 2501 A		33	
	25	LWE..Q, LWET..Q, LWES..Q, LWEC, LWEC..SL, LWE, LWE..SL, LWEG, LWEG..SL, LWETC, LWETC..SL, LWET, LWET..SL; LWETG, LWETG..SL, LWESC, LWESC..SL, LWES, LWES..SL, LWESG, LWESG..SL	HK 2501 A		33	17
		LWE..Q, LWET..Q, LWES..Q, LWEC, LWEC..SL, LWE, LWE..SL, LWEG, LWEG..SL, LWETC, LWETC..SL, LWET, LWET..SL; LWETG, LWETG..SL, LWESC, LWESC..SL, LWES, LWES..SL, LWESG, LWESG..SL	HK 3001 A		42	
30	LWE..Q, LWET..Q, LWES..Q, LWEC, LWEC..SL, LWE, LWE..SL, LWEG, LWEG..SL, LWETC, LWETC..SL, LWET, LWET..SL; LWETG, LWETG..SL, LWESC, LWESC..SL, LWES, LWES..SL, LWESG, LWESG..SL	HK 3001 A		42	28	
	LWE..Q, LWET..Q, LWES..Q, LWEC, LWEC..SL, LWE, LWE..SL, LWEG, LWEG..SL, LWETC, LWETC..SL, LWET, LWET..SL; LWETG, LWETG..SL, LWESC, LWESC..SL, LWES, LWES..SL, LWESG, LWESG..SL	HK 3501 A		48		
35	LWE..Q, LWET..Q, LWES..Q, LWEC, LWEC..SL, LWE, LWE..SL, LWEG, LWEG..SL, LWETC, LWETC..SL, LWET, LWET..SL; LWETG, LWETG..SL, LWESC, LWESC..SL, LWES, LWES..SL, LWESG, LWESG..SL	HK 3501 A		48	35	
	LWE..Q, LWET..Q, LWES..Q, LWEC, LWEC..SL, LWE, LWE..SL, LWEG, LWEG..SL, LWETC, LWETC..SL, LWET, LWET..SL; LWETG, LWETG..SL, LWESC, LWESC..SL, LWES, LWES..SL, LWESG, LWESG..SL	HK 4501 A		60		
45	LWE, LWET, LWES	HK 4501 A		60	43	
	LWE, LWET, LWES	HK 4501 A		60		
LRX	15	LRXC, LRX, LRXG, LRXSC, LRXS, LRXSG	HK 1510 B		24	5
		LRXDC, LRXD, LRXDG	HK 1510 B	PHK 15-4/01	28	
	20	LRXC, LRX, LRXG, LRXSC, LRXS, LRXSG	HK 2010 B		30	10
		LRXDC, LRXD, LRXDG	HK 2010 B	PHK 20-4	34	
	25	LRXC, LRX, LRXG, LRXSC, LRXS, LRXSG	☉		36	22
		LRXDC, LRXD, LRXDG	HK 2501 A		40	
	30	LRXC, LRX, LRXG, LRXSC, LRXS, LRXSG	☉		42	29
		LRXDC, LRXD, LRXDG	HK 3001 A		45	
	35	LRXC, LRX, LRXG, LRXDC, LRXD, LRXDG	HK 3501 A		48	35
		LRXC, LRX, LRXG, LRXDC, LRXD, LRXDG	HK 3501 A	PMK 35-7	55	
	45	LRXC, LRX, LRXG, LRXDC, LRXD, LRXDG	HK 4501 A		60	43
		LRXC, LRX, LRXG, LRXDC, LRXD, LRXDG	HK 4501 A	PHK 45-10	70	
	55	LRXC, LRX, LRXG, LRXDC, LRXD, LRXDG	HK 5501 A		70	62
		LRXC, LRX, LRXG, LRXDC, LRXD, LRXDG	HK 5501 A	PHK 55-10	80	
65	LRXC, LRX, LRXG, LRXDC, LRXD, LRXDG	HK 6510 R		90	44	
	LRXC, LRX, LRXG, LRXDC, LRXD, LRXDG	HK 6510 R		90		

Rail manufacturer

**IKO**

LRX: For rail use with cover sheet please contact us!

\*<sup>1</sup> Only required for high carriage design

\*<sup>2</sup> Supplements the measure table and datasheet

See page 12 for part number explanation

HK

Rail manufacturer



Type of rail	Size	Type of carriage	Item number	Adapting plate <sup>*1</sup> (for height compensation)	Measure D [mm]	Measure table (page 112 and 113) <sup>*2</sup>	
TKD (KUJE)	15	KWE	HK 1501 A		24	3	
		KWE..-H	HK 1501 A	PHK 15-4	28		
	20	KWE, KWE..-H	HK 2001 A		30	11	
		KWE	HK 2501 A	PHK 25-4	36	15	
	25	KWE..-H	HK 2501 A	PHK 25-8	40		
		KWE	HK 3001 A	PHK 30-4	42	25	
	30	KWE..-H	HK 3001 A	PHK 30-7	45		
KWE		HK 3501 A	PMK 35-8	48	30		
35	KWE..-H	HK 3501 A	PMK 35-15	55			
	KWE	HK 3501 A					
TKSD (KUJE)	20	KWSE, KWSE..-L, KWSE..-H, KWSE..-HL	HK 2001 A		30	11	
	25	KWSE, KWSE..-L	HK 2501 A		36	21	
		KWSE..-H, KWSE..-HL	HK 2501 A	PHK 25-4	40		
	30	KWSE, KWSE..-L	HK 3001 A		42	28	
		KWSE..-H, KWSE..-HL	HK 3001 A	PHK 30-3	45		
	35	KWSE, KWSE..-L	HK 3501 A		48	35	
		KWSE..-H, KWSE..-HL	HK 3501 A	PMK 35-7	55		
	45	KWSE, KWSE..-L	HK 4501 A		60	43	
		KWSE..-H, KWSE..-HL	HK 4501 A	PHK 45-10	70		
	55	KWSE, KWSE..-L	HK 5501 A		70	62	
		KWSE..-H, KWSE..-HL	HK 5501 A	PHK 55-10	80		
TKVD (KUVE)	15	KWVE..-B, KWVE..-B-EC, KWVE..-E, KWVE..-ES, KWVE..-B-ESC, KWVE..-B-S, KWVE..-B-KT, KWVE..-B-KT-L, KWVE..-B-KT-S, KWVE..-B-KT-SL, KWVE..-B-H, KWVE..-B-KT-H, KWVE..-B-KT-HL	HK 1502 K		24	3	
			HK 1502 K	PHK 15-4	28		
			HK 2002 K		30	12	
	20	KWVE..-B, KWVE..-B-L, KWVE..-B-S, KWVE..-B-SL, KWVE..-B-KT, KWVE..-B-KT-L, KWVE..-B-KT-S, KWVE..-B-KT-SL, KWVE..-B-N, KWVE..-B-NL, KWVE..-B-SN, KWVE..-B-SNL, KWVE..-E, KWVE..-B-EC, KWVE..-ES, KWVE..-B-ESC	HK 2002 K		27	7	
			HK 2002 K		28	9	
			HK 2502 K	PHK 25-4	36	16	
	25	KWVE..-B, KWVE..-B-L, KWVE..-B-S, KWVE..-B-SL, KWVE..-B-KT, KWVE..-B-KT-L, KWVE..-B-KT-S, KWVE..-B-KT-SL, KWVE..-B-N, KWVE..-B-NL, KWVE..-B-SN, KWVE..-B-SNL, KWVE..-E, KWVE..-B-EC, KWVE..-ES, KWVE..-B-ESC, KWVE..-ES-K, KWVE..-ESC-K	HK 2502 K		31	14	
			HK 2502 K		33	18	
			HK 2502 K		40	18	
			HK 2502 K	PHK 25-7	40	18	
			HK 2502 K		40	18	
	30	KWVE..-B, KWVE..-B-EC, KWVE..-B-L, KWVE..-E, KWVE..-ES, KWVE..-B-ESC, KWVE..-B-S, KWVE..-B-SL, KWVE..-B-KT, KWVE..-B-KT-L, KWVE..-B-KT-S, KWVE..-B-KT-SL, KWVE..-B-N, KWVE..-B-NL, KWVE..-B-SN, KWVE..-B-SNL, KWVE..-B-H, KWVE..-B-HL, KWVE..-B-KT-H, KWVE..-B-KT-HL	HK 3002 K		42	28	
			HK 3002 K		38	25	
			HK 3002 K	PHK 30-3	45	28	
			HK 3002 K		45	28	
	35	KWVE..-B, KWVE..-B-EC, KWVE..-B-L, KWVE..-E, KWVE..-ES, KWVE..-B-ESC, KWVE..-B-S, KWVE..-B-SL, KWVE..-B-KT, KWVE..-B-KT-L, KWVE..-B-KT-S, KWVE..-B-KT-SL, KWVE..-B-N, KWVE..-B-NL, KWVE..-B-SN, KWVE..-B-SNL, KWVE..-B-H, KWVE..-B-HL, KWVE..-B-KT-H, KWVE..-B-KT-HL	HK 3502 K	PMK 35-4	48	31	
			HK 3502 K		44		
			HK 3502 K	PMK 35-11	55		
	45	KWVE..-B, KWVE..-B-EC, KWVE..-B-L, KWVE..-E, KWVE..-ES, KWVE..-B-ESC, KWVE..-B-S, KWVE..-B-SL, KWVE..-B-KT, KWVE..-B-KT-L, KWVE..-B-KT-S, KWVE..-B-KT-SL, KWVE..-B-N, KWVE..-B-NL, KWVE..-B-SN, KWVE..-B-SNL, KWVE..-B-H, KWVE..-B-HL, KWVE..-B-KT-H, KWVE..-B-KT-HL	HK 4502 K		60	41	
			HK 4502 K		52	40	
			HK 4502 K	PHK 45-10	70	41	
	55	KWVE..-B, KWVE..-B-L, KWVE..-B-S, KWVE..-B-SL, KWVE..-B-KT, KWVE..-B-KT-L, KWVE..-B-KT-S, KWVE..-B-KT-SL	HK 4502 K		70		
			HK 4502 K		70		
	TKVD..W (KUVE..W)	15	KWVE..-W	HK 1502 KB		21	4
		20	KWVE..-W	HK 2002 KB		27	24
		25	KWVE..-WL, KWVE..-B-KT-W, KWVE..-B-KT-WL	HK 2502 KB		35	37
		30	KWVE..-W	⊙			
35		KWVE..-WL	HK 3502 KB		50	50	

<sup>\*1</sup> Only required for high carriage design

<sup>\*2</sup> Supplements the measure table and datasheet

See page 12 for part number explanation

Type of rail	Size	Type of carriage	Item number	Adapting plate <sup>*1</sup> (for height compensation)	Measure D [mm] <sup>*2</sup>	Measure table (page 112 and 113)
TSX..D (RUE)	25	RWU..-D, RWU..-D-L	HK 2502 R		36	21
		RWU..-D-H, RWU..-D-HL	HK 2502 R	PHK 25-4	40	
	35	RWU..-E, RWU..-E-L, RWU..-E-KT-L	HK 3502 R		48	35
		RWU..-E-H, RWU..-E-HL, RWU..-E-KT-HL	HK 3502 R	PMK 35-7	55	
	45	RWU..-E, RWU..-E-L, RWU..-E-KT-L	HK 4502 R		60	43
		RWU..-E-H, RWU..-E-HL, RWU..-E-KT-HL	HK 4502 R	PHK 45-10	70	
	55	RWU..-E, RWU..-E-L, RWU..-E-KT-L	HK 5502 R		70	47
		RWU..-E-H, RWU..-E-HL, RWU..-E-KT-HL	HK 5502 R	PHK 55-10	80	
	65	RWU..-E, RWU..-E-L	HK 6502 R		90	53
		RWU..-E-H, RWU..-E-HL	HK 6502 R	PHK 65-10	100	

Rail manufacturer



LH	15	LAH..EMZ, LAH..GMZ	HK 1501 A		24	3
		LAH..ANZ, LAH..BNZ	HK 1501 A	PHK 15-4	28	
	20	LAH..EMZ, LAH..GMZ, LAH..ANZ, LAH..BNZ	HK 2001 A		30	11
	25	LAH..EMZ, LAH..GMZ, LAH..ALZ, LAH..BLZ	HK 2501 A		36	21
		LAH..ANZ, LAH..BNZ	HK 2501 A	PHK 25-4	40	
	30	LAH..EMZ, LAH..GMZ, LAH..ALZ, LAH..BLZ	HK 3001 A		42	28
		LAH..ANZ, LAH..BNZ	HK 3001 A	PHK 30-3	45	
	35	LAH..EMZ, LAH..GMZ, LAH..ALZ, LAH..BLZ	HK 3501 A		48	35
		LAH..ANZ, LAH..BNZ	HK 3501 A	PMK 35-7	55	
	45	LAH..EMZ, LAH..GMZ	HK 4501 A		60	43
LAH..ANZ, LAH..BNZ		HK 4501 A	PHK 45-10	70		
55	LAH..EMZ, LAH..GMZ	HK 5501 A		70	62	
	LAH..ANZ, LAH..BNZ	HK 5501 A	PHK 55-10	80		
65	LAH..EMZ, LAH..GMZ, LAH..ANZ, LAH..BNZ	HK 6501 A		90	53	
SH	15	SAH..EMZ, SAH..GMZ	HK 1501 A		24	3
		SAH..ANZ, SAH..BNZ	HK 1501 A	PHK 15-4	28	
	20	SAH..EMZ, SAH..GMZ, SAH..ANZ, SAH..BNZ	HK 2001 A		30	11
	25	SAH..EMZ, SAH..GMZ, SAH..ALZ, SAH..BLZ	HK 2501 A		36	21
		SAH..ANZ, SAH..BNZ	HK 2501 A	PHK 25-4	40	
	30	SAH..EMZ, SAH..GMZ, SAH..ALZ, SAH..BLZ	HK 3001 A		42	28
		SAH..ANZ, SAH..BNZ	HK 3001 A	PHK 30-3	45	
	35	SAH..EMZ, SAH..GMZ, SAH..ALZ, SAH..BLZ	HK 3501 A		48	35
		SAH..ANZ, SAH..BNZ	HK 3501 A	PMK 35-7	55	
	LS	15	LAS..KLZ, LAS..JMZ, LAS..EMZ, LAS..CLZ, LAS..ALZ	HK 1501 A	PHK 15-2	24
20		LAS..KLZ, LAS..JMZ, LAS..EMZ, LAS..CLZ, LAS..ALZ	HK 2001 A		28	8
25		LAS..KLZ, LAS..JMZ, LAS..EMZ, LAS..CLZ, LAS..ALZ	HK 2501 A		33	17
30		LAS..KLZ, LAS..FLZ, LAS..ELZ, LAS..CLZ, LAS..ALZ	HK 3001 A	PHK 30-4	42	25
35		LAS..KLZ, LAS..FLZ, LAS..ELZ, LAS..CLZ, LAS..ALZ	HK 3501 A		48	35
SS	15	SAS..KLZ, SAS..EMZ, SAS..CLZ, SAS..ALZ	HK 1501 A	PHK 15-2	24	1
	20	SAS..KLZ, SAS..EMZ, SAS..CLZ, SAS..ALZ	HK 2001 A		28	8
	25	SAS..KLZ, SAS..EMZ, SAS..CLZ, SAS..ALZ	HK 2501 A		33	17
	30	SAS..KLZ, SAS..EMZ, SAS..CLZ, SAS..ALZ	HK 3001 A	PHK 30-4	42	25
	35	SAS..KLZ, SAS..EMZ, SAS..CLZ, SAS..ALZ	HK 3501 A		48	35
LY	15	LY..EL, LY..FL, LY..AL	HK 1501 A		24	3
		LY..AN	HK 1501 A	PHK 15-4	28	
	20	LY..EL, LY..FL, LY..GL, LY..HL, LY..AL, LY..BL	HK 2001 A		30	11
	25	LY..EL, LY..FL, LY..GL, LY..HL, LY..AL, LY..BL	HK 2501 A		36	21
		LY..AN, LY..BN	HK 2501 A	PHK 25-4	40	
	30	LY..EL, LY..FL, LY..GL, LY..HL, LY..AL, LY..BL	HK 3001 A		42	28
		LY..AN, LY..BN	HK 3001 A		45	29
	35	LY..EL, LY..FL, LY..GL, LY..HL, LY..AL, LY..BL	HK 3501 A		48	35
		LY..AN, LY..BN	HK 3501 A	PMK 35-7	55	
	45	LY..EL, LY..FL, LY..GL, LY..HL, LY..AL, LY..BL	HK 4501 A		60	43
LY..AN, LY..BN		HK 4501 A	PHK 45-10	70		
55	LY..EL, LY..FL, LY..GL, LY..HL, LY..AL, LY..BL	HK 5501 A		70	62	
	LY..AN, LY..BN	HK 5501 A	PHK 55-10	80		
65	LY..EL, LY..FL, LY..GL, LY..HL, LY..AN, LY..BN	HK 6501 A		90	53	

Rail manufacturer



\*1 Only required for high carriage design

\*2 Supplements the measure table and datasheet

See page 12 for part number explanation

HK



Rail manufacturer

**NSK**

Type of rail	Size	Type of carriage	Item number	Adapting plate <sup>*1</sup> (for height compensation)	Measure D [mm] <sup>*2</sup>	Measure table (page 112 and 113)
LA	25	LA..EL, LA..GL, LA..FL, LA..HL	HK 2501 A		36	21
		LA..AN, LA..BN	HK 2501 A	PHK 25-4	40	
	30	LA..EL, LA..GL, LA..FL, LA..HL	HK 3001 A		42	28
		LA..AN, LA..BN	HK 3001 A		45	29
	35	LA..EL, LA..GL, LA..FL, LA..HL, LA..AL, LA..BL	HK 3501 A		48	35
		LA..AN, LA..BN	HK 3501 A	PMK 35-7	55	
	45	LA..EL, LA..GL, LA..FL, LA..HL, LA..AL, LA..BL	HK 4501 A		60	43
		LA..AN, LA..BN	HK 4501 A	PHK 45-10	70	
55	LA..EL, LA..GL, LA..FL, LA..HL, LA..AL, LA..BL	HK 5501 A		70	62	
	LA..AN, LA..BN	HK 5501 A	PHK 55-10	80		
65	LA..EL, LA..GL, LA..FL, LA..HL, LA..AN, LA..BN	HK 6501 A		90	53	
LW	17	LW..ELZ	HK 1701 B		17	39
	21	LW..ELZ	HK 2101 B		21	23
	27	LW..ELZ	HK 2701 B		27	24
	35	LW..ELZ	HK 3501 B		35	45
	50	LW..ELZ	HK 5001 B		50	50
RA	15	RA..AL, RA..BL, RA..EM, RA..GM	⊙		24	
		RA..AN, RA..BN	⊙		28	
	20	RA..EM, RA..GM, RA..AN, RA..BN	⊙		30	
	25	RA..AL, RA..BL, RA..EM, RA..GM	⊙		36	
		RA..AN, RA..BN	⊙		40	
	30	RA..AL, RA..BL, RA..EM, RA..GM	⊙		42	
		RA..AN, RA..BN	⊙		45	
	35	RA..AL, RA..BL, RA..EM, RA..GM	⊙		48	
		RA..AN, RA..BN	⊙		55	
	45	RA..AL, RA..BL, RA..EM, RA..GM	⊙		60	
		RA..AN, RA..BN	⊙		70	
	55	RA..AL, RA..BL, RA..EM, RA..GM	⊙		70	
		RA..AN, RA..BN	⊙		80	
	65	RA..EM, RA..GM, RA..AN, RA..BN	⊙		90	

Rail manufacturer

**ROLLON**

MR	15	MRS, MRS..C, MRT..W, MRT..SW	HK 1501 A		24	3
		MRS..W	HK 1501 A	PHK 15-4	28	
	20	MRT..S, MRT..SC, MRT..W, MRT..SW	HK 2001 A		28	11
		MRS, MRS..L, MRS..C, MRS..LC, MRS..W, MRS..LW	HK 2001 A	PHK 20-2	30	
	25	MRT, MRT..S, MRT..C, MRT..SC, MRT..W, MRT..SW, MRT..LW..	HK 2514 A		33	34
		MRS, MRS..L, MRS..C, MRS..LC	HK 2501 A		36	21
	30	MRS..W, MRS..LW	HK 2501 A	PHK 25-4	40	
		MRS, MRS..L, MRS..C, MRS..LC, MRT..W, MRT..SW, MRT..LW	HK 3001 A		42	28
	35	MRS..W, MRS..LW	HK 3001 A	PHK 30-3	45	
		MRS, MRS..L, MRT..W, MRT..SW, MRT..LW	HK 3501 A		48	35
	45	MRS..W, MRS..LW	HK 3501 A	PMK 35-7	55	
		MRS, MRS..L, MRT..W, MRT..LW	HK 4501 A		60	43
	55	MRS..W, MRS..LW	HK 4501 A	PHK 45-10	70	
		MRT..W, MRT..LW	⊙		68	
	62	MRS, MRS..L	HK 5501 A		70	62
		MRS..W, MRS..LW	HK 5501 A	PHK 55-10	80	

<sup>\*1</sup> Only required for high carriage design

<sup>\*2</sup> Supplements the measure table and datasheet

See page 12 for part number explanation

Type of rail	Size	Type of carriage	Item number	Adapting plate <sup>*1</sup> (for height compensation)	Measure D [mm] <sup>*2</sup>	Measure table (page 112 and 113)
<b>LGR..T</b> <b>LGR..R</b>	15	LGW..CC	HK 1501 A		24	3
		LGH..CA	HK 1501 A	PHK 15-4	28	
	20	LGW..CC, LGW..HC, LGH..CA, LGH..HA	HK 2001 A	PHK 20-4	30	6
		LGW..CC, LGW..HC	HK 2501 A		36	21
	30	LGH..CA, LGH..HA	HK 2501 A	PHK 25-4	40	
		LGW..CC, LGW..HC	HK 3001 A		42	28
	35	LGH..CA, LGH..HA	HK 3001 A	PHK 30-3	45	
		LGW..CC, LGW..HC	HK 3501 A	PMK 35-4	48	31
	45	LGH..CA, LGH..HA	HK 3501 A	PMK 35-10	55	32
		LGW..CC, LGW..HC	HK 4501 A		60	43
	55	LGH..CA, LGH..HA	HK 4501 A	PHK 45-10	70	
LGW..CC, LGW..HC		HK 5501 A		70	62	
65	LGH..CA, LGH..HA	HK 5501 A	PHK 55-10	80		
	LGW..CC, LGW..HC, LGH..CA, LGH..HA	HK 6501 A		90	53	
<b>HGR..T</b> <b>HGR..R</b>	15	HGW..CC	HK 1501 A		24	3
		HGH..CA	HK 1501 A	PHK 15-4	28	
	20	HGW..CC, HGW..HC, HGH..CA, HGH..HA	HK 2001 A	PHK 20-1	30	63
		HGW..CC, HGW..HC	HK 2501 A		36	21
	30	HGH..CA, HGH..HA	HK 2501 A	PHK 25-4	40	
		HGW..CC, HGW..HC	HK 3001 A		42	28
	35	HGH..CA, HGH..HA	HK 3001 A	PHK 30-3	45	
		HGW..CC, HGW..HC	HK 3501 A		48	35
	45	HGH..CA, HGH..HA	HK 3501 A	PMK 35-7	55	
		HGW..CC, HGW..HC	HK 4501 A		60	43
	55	HGH..CA, HGH..HA	HK 4501 A	PHK 45-10	70	
HGW..CC, HGW..HC		HK 5501 A		70	62	
65	HGH..CA, HGH..HA	HK 5501 A	PHK 55-10	80		
	HGW..CC, HGW..HC, HGH..CA, HGH..HA	HK 6501 A		90	53	
<b>EGR..T</b>	15	EGH...SA, EGH...CA, EGW...SC, EGW...CC	HK 1501 A	PHK 15-3	24	36
		EGH...SA, EGH...CA, EGW...SC, EGW...CC	HK 2001 A		28	8
	25	EGH...SA, EGH...CA, EGW...SC, EGW...CC	HK 2501 A	PHK 25-1	33	15
		EGH...SA, EGH...CA, EGW...SC, EGW...CC	HK 3001 A		42	28
<b>RG..T</b>	25	RGW..CC, RGW..HC	⊗		36	
		RGH..CA, RGH..HA	⊗		40	
	30	RGW..CC, RGW..HC	HK 3001 A		42	28
		RGH..CA, RGH..HA	HK 3001 A		45	29
	35	RGW..CC, RGW..HC	HK 3501 A		48	35
		RGH..CA, RGH..HA	HK 3501 A	PMK 35-7	55	
	45	RGW..CC, RGW..HC	⊗		60	
		RGH..CA, RGH..HA	⊗		70	
	55	RGW..CC, RGW..HC	HK 5501 A		70	62
		RGH..CA, RGH..HA	HK 5501 A	PHK 55-10	80	
65	RGW..CC, RGW..HC, RGH..CA, RGH..HA	⊗		90		

Rail manufacturer

**HIWIN**  
Lineartechnologie

<sup>\*1</sup> Only required for high carriage design

<sup>\*2</sup> Supplements the measure table and datasheet

See page 12 for part number explanation

HK

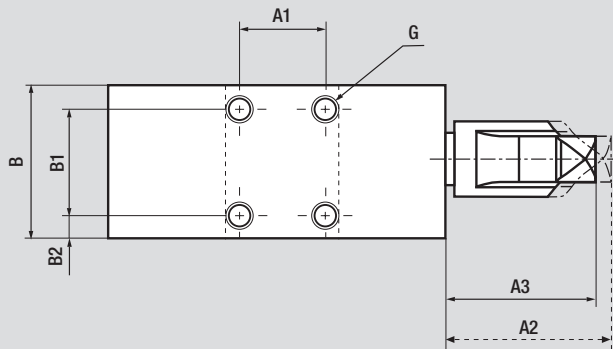
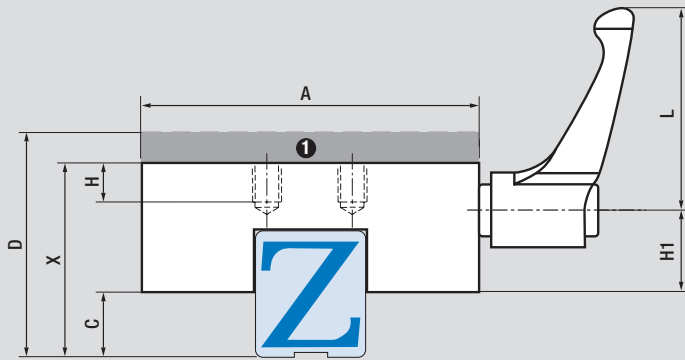

**Note:** Consider measurement C!

❶ Adapting plate ( accessories )

X = measure of function to be complied

D = Dimension of installation-linear guide  
(if necessary with adapting plate accessories)

Measure table	Holding power [N] HK Fastening torque [Nm]	A [mm]	A1 [mm]	A2 [mm]	A3 [mm]	B [mm]	B1 [mm]	B2 [mm]	C [mm]	X [mm]	G	L [mm]	H [mm]	H1 [mm]
1	1200/5	47	17	33,5	30,5	25	17	4	4,5	22	M4	44	5	12,5
2	1200/4	47	17	33,5	30,5	25	17	4	5	24	M4	44	5	14,3
3	1200/5	47	17	33,5	30,5	25	17	4	6,5	24	M4	44	5	12,5
4	1200/5	69	17	33,5	30,5	25	17	4	3,5	21	M4	44	5	12,5
5	1200/7	47	38	33,5	30,5	29	20	4,5	6,5	24	M5	44	6	13,4
6	1200/7	60	15	41,5	38,5	24	15	4,5	6	26	M5	63	6	13
7	1200/4	60	15	33,5	30,5	24	15	4,5	8	27	M5	44	6	12,5
8	1200/7	60	15	41,5	38,5	24	15	4,5	8	28	M5	63	6	13
9	1200/4	60	15	33,5	30,5	24	15	4,5	9	28	M5	44	6	12,5
10	1200/5	60	15	33,5	30,5	24	15	4,5	7	30	M5	44	6	17,5
11	1200/7	60	15	41,5	38,5	24	15	4,5	10	30	M5	63	6	13
12	1200/4	60	15	33,5	30,5	24	15	4,5	11	30	M5	44	5	12,5
13	1200/7	72	20	41,5	38,5	30	20	5	7	31	M6	63	8	15
14	1200/7	70	20	41,5	38,5	30	20	5	8	31	M6	63	6	15,5
15	1200/7	70	20	41,5	38,5	30	20	5	8	32	M6	63	8	15
16	1200/7	70	20	41,5	38,5	30	20	5	9	32	M6	63	6	15,5
17	1200/7	70	20	41,5	38,5	30	20	5	9	33	M6	63	8	15
18	1200/7	70	20	41,5	38,5	30	20	5	10	33	M6	63	6	15,5
19	1200/7	70	20	41,5	38,5	30	20	5	10	34	M6	63	8	15
20	1200/7	70	20	41,5	38,5	30	20	5	7	36	M6	63	7	22,3
21	1200/7	70	20	41,5	38,5	30	20	5	12	36	M6	63	8	15
22	1200/7	70	20	41,5	38,5	30	20	5	16	40	M6	63	8	15
23	1200/4	77	24	33,5	30,5	24	15	4,5	3	21	M5	44	6	12,5
24	1200/4	80	20	33,5	30,5	30	20	5	4	27	M6	44	6	17
25	2000/15	90	22	50,5	46,5	39	22	8,5	8	38	M6	78	8	21,5
26	2000/15	90	22	50,5	46,5	39	22	8,5	8	42	M6	78	8	21,5
27	2000/15	90	22	50,5	46,5	39	22	8,5	9	42	M6	78	8	25
28	2000/15	90	22	50,5	46,5	39	22	8,5	12	42	M6	78	8	21,5
29	2000/15	90	22	50,5	46,5	39	22	8,5	15	45	M6	78	8	21,5
30	2000/15	100	24	50,5	46,5	39	24	7,5	8	40	M8	78	10	21,5
31	2000/15	100	24	50,5	46,5	39	24	7,5	12	44	M8	78	10	21,5
32	2000/15	100	24	50,5	46,5	39	24	7,5	13	45	M8	78	10	21,5
33	2000/15	100	24	50,5	46,5	39	24	7,5	7	48	M8	78	10	31
34	1200/7	70	20	41,5	38,5	30	20	5	11,5	33	M6	63	8	15
35	2000/15	100	24	50,5	46,5	39	24	7,5	16	48	M8	78	10	21,5
36	1200/5	47	17	33,5	30,5	25	17	4	3,5	21	M4	44	5	12,5
37	1200/7	118	20	41,5	38,5	30	20	5	11	35	M6	63	8	13,5
38	1200/7	120	50	41,5	38,5	39	25	7	5	35	M6	63	11	23,2
39	1200/4	60	17	33,5	30,5	25	17	4	2,5	17	M4	44	5	10
40	2000/15	120	26	50,5	46,5	44	26	9	10	52	M10	78	14	26,5
41	2000/15	120	26	50,5	46,5	44	26	9	12	60	M10	78	12,5	35,7
42	2000/15	120	26	50,5	46,5	44	26	9	12	60	M10	78	14	35
43	2000/15	120	26	50,5	46,5	44	26	9	18	60	M10	78	14	26,5
44	2000/18	170	35	61,5	56,5	64	35	14,5	26	90	M16	95	20	38,5
45	2000/15	135	50	50,5	46,5	39	20	9,5	4	35	M8	78	10	20,5
46	2000/22	140	30	61,5	56,5	49	30	9,5	14	63	M14	95	16	31
47	2000/22	140	30	61,5	56,5	49	30	9,5	19	70	M14	95	14	37,5
48	2000/22	140	30	61,5	56,5	49	30	9,5	19	68	M14	95	16	31
49	1200/4	80	15	33,5	30,5	24	15	4,5	4	27	M5	44	10	18,8
50	2000/15	145	60	50,5	46,5	39	20	9,5	11	50	M8	78	11	29,9
51	2000/22	160	35	61,5	56,5	64	35	14,5	24	90	M16	95	20	45,5
52	2000/22	170	35	61,5	56,5	64	35	14,5	15	75	M16	95	21	36
53	2000/22	170	35	61,5	56,5	64	35	14,5	26	90	M16	95	24	36
54	130/3	34	10	33,5	30,5	20	10	5	4,2	24	M3	40	6	12,9
55	250/3	44	12	33,5	30,5	24	12	6	6	30	M4	40	6	16
56	330/3	48	15	33,5	30,5	30	15	7,5	7	36	M5	44	7	19,6
57	2000/15	57	18	50,5	46,5	29	18	5,5	12	33	M6	78	8	13
58	1200/4	32	17	33,5	30,5	25	17	4	7	20	M4	44	5	7,8
59	1200/5	43	15	33,5	30,5	24	15	4,5	8,5	24	M5	44	6	8,8
60	1200/7	47	20	41,5	38,5	30	20	5	11	30	M6	63	7	10
61	2000/15	68	24	50,5	46,5	39	24	7,5	14	38	M8	78	10	15
62	2000/22	140	30	61,5	56,5	49	30	9,5	21	70	M14	95	16	31
63	1200/7	60	15	41,5	38,5	24	15	4,5	9	29	M5	63	6	13
64	2000/15	120	26	50,5	46,5	44	26	9	4	52	M10	78	12,5	35,7

HK