

SmartMotor™ Series	SM23165MT-IP	
Continuous Torque @ 48V	4.17	in-lb
	67	oz-in
	0.47	N-m
Peak Torque	7.78	in-lb
	124	oz-in
	0.88	N-m
Nominal Continuous Power	194	Watt
	0.19	kW
	0.26	HP
No Load Speed	5,000	RPM
Continuous Current @ Nominal Power	4.8	Amps
Voltage Constant	9.08	V/kRPM
Winding Resistance	0.7	ohms
Encoder Resolution	4000	Counts/Rev
Rotor Inertia	0.001	oz-in-sec <sup>2</sup>
	0.706	10 <sup>-5</sup> kg-m <sup>2</sup>
Weight	1.5	lb
	0.68	kg
Shaft Diameter	0.375	in
	9.53	mm
Shaft, Radial Load	15	lb
	6.80	kg
Shaft, Axial Thrust Load	3	lb
	1.36	kg
DeviceNet Version	SM23165MT-IP-DN	
CANopen Version	SM23165MT-IP-C	



### All New Class 5 Features and IP65 rated

- Complete barrier against dust and other harmful particles
- Longer motor life
- Splash protected\* for wet environments unlike drip-proof competitors
- New industry capabilities such as food and beverage manufacturing and packaging, demanding outdoor conditions, and nautical machinery

\* Not submersible

### Animatics SmartMotor SM23165MT (No Options) CAD Drawing

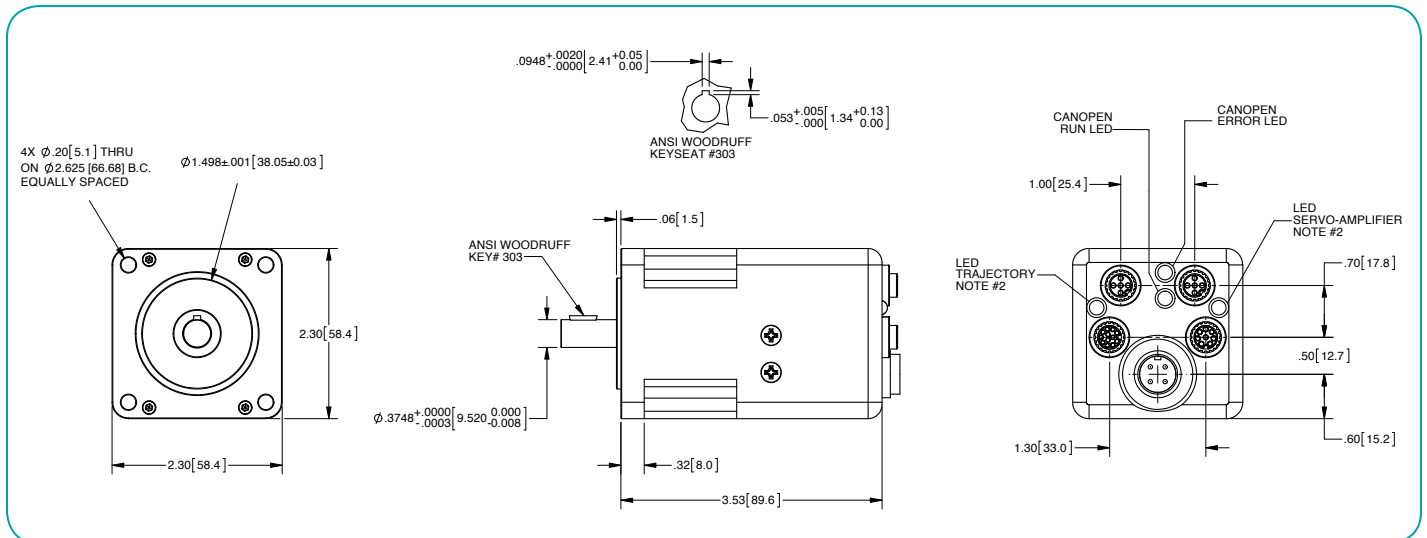

**NOTE: Drive Power and Control Power are Separate Inputs. Control Power is rated to a maximum range of 18 to 32VDC. Drive Power is from 18 to 48VDC max.**



# IP 65 Models

Animatics' new SM23165MT SmartMotor™ with M-style connectors offers the same IP65 ratings with the added convenience of a smaller frame size for more compact applications. The second in a series of harsh environment-rated products from Animatics, the SM23165MT combines the quality and durability of the SmartMotor integrated servo in combination with an IP65 rating adding tremendous value to an already strong product series.



dust tight but it's also protected from ingress of liquid that may occur from any angle, rendering no harmful effects on the electrical enclosure. The SM23165MT-IP can withstand splashing water, oil or food debris as well as rainy conditions. Conditions with high levels of humidity and condensation are no longer a problem. This makes the SM23165MT-IP with the IP65 rating the perfect integrated servo for food and beverage manufacturing and packaging, rugged outdoor conditions, as well as any wet processing environment.



For the IP65 rated SmartMotor, not only is it completely

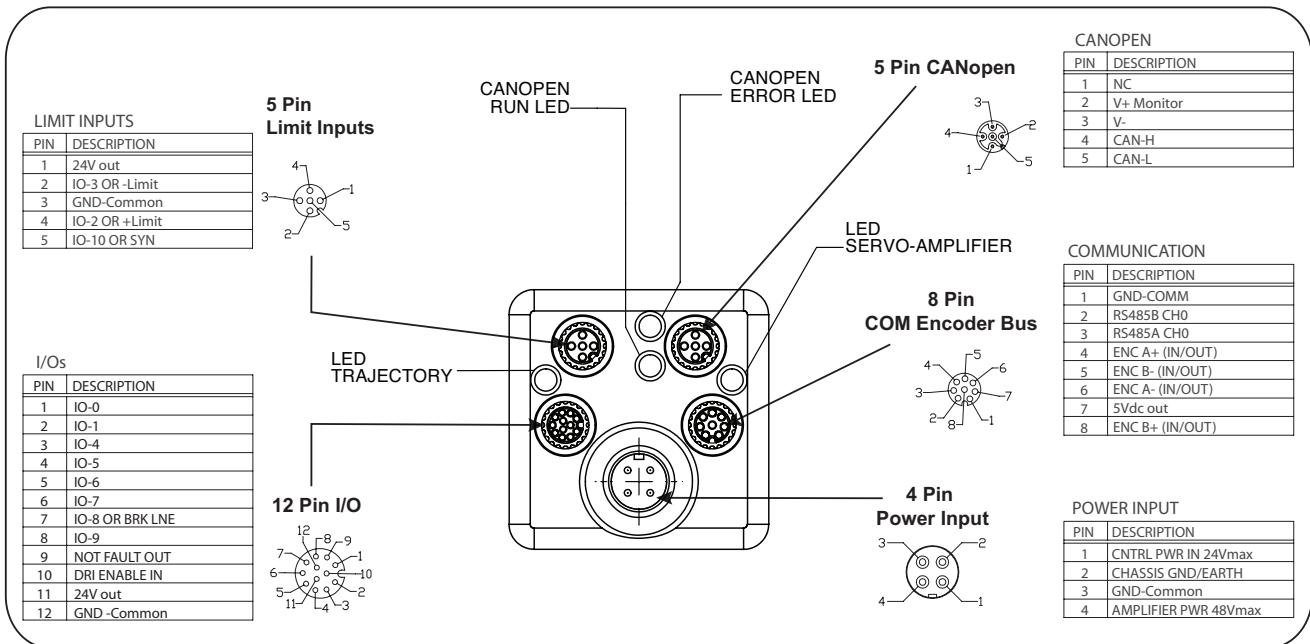

## Torque Curve

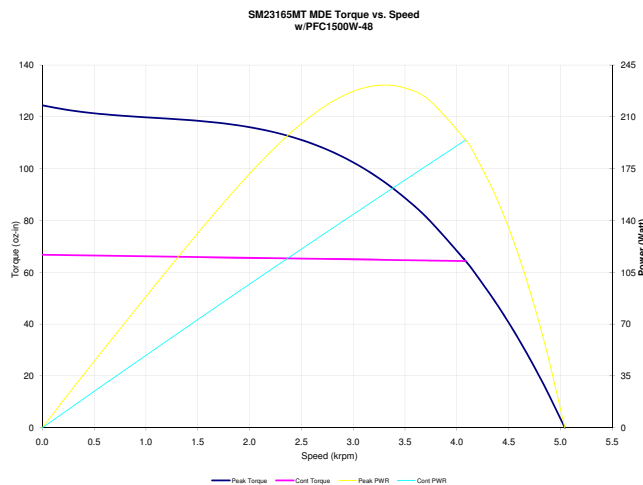

**SM23165MT-IP**  
at 48 VDC  
at rise to 85°C

All torque curves were derived under dynamometer testing at an ambient temperature of 25°C with a heat rise of level shown for continuous curves. These are maximum values obtained for dyno tested torques as shown in the catalog which can be found at [www.animatics.com](http://www.animatics.com).

Consult Factory or your nearest Automation Solution Provider (ASP) for Manual, Software and Accessories.