

OVERVIEW  
MOTOR SPECIFICATIONS  
LINEAR SYSTEMS  
CONNECTIVITY  
PERIPHERALS  
IP 65 MODELS & CONNECTIVITY  
POWER SUPPLIES & SHUNTS  
GEAR HEADS  
SOFTWARE  
APPENDIX

SmartMotor™ Series	SM34165MT-IP	
Continuous Torque @ 48V	12.58	in-lb
	201	oz-in
	1.42	N-m
Peak Torque	21.57	in-lb
	345	oz-in
	2.44	N-m
Nominal Continuous Power	448	Watt
	0.45	kW
	0.60	HP
No Load Speed	5,100	V/kRPM
Continuous Current @ Nominal Power	15.5	Amps
Voltage Constant	8.9	V/kRPM
Winding Resistance	0.06	ohms
Encoder Resolution	8000	Counts/Rev
Rotor Inertia	0.0142	oz-in-sec <sup>2</sup>
	10.031	10 <sup>-5</sup> kg-m <sup>2</sup>
Weight	6.0	lb
	2.72	kg
Shaft Diameter	0.50	in
	12.70	mm
Shaft, Radial Load	30	lb
	13.61	kg
Shaft, Axial Thrust Load	3	lb
	1.36	kg
DeviceNet Version	SM34165MT-IP-DN	
CANopen Version	SM34165MT-IP-C	



IP67  
Rated  
Optional

### All New Class 5 Features and IP65 rated

- Complete barrier against dust and other harmful particles
- Longer motor life
- Splash protected\* for wet environments unlike drip-proof competitors
- New industry capabilities such as food and beverage manufacturing and packaging, demanding outdoor conditions, and nautical machinery

\* Not submersible

### Animatics SmartMotor SM34165MT (No Options) CAD Drawing

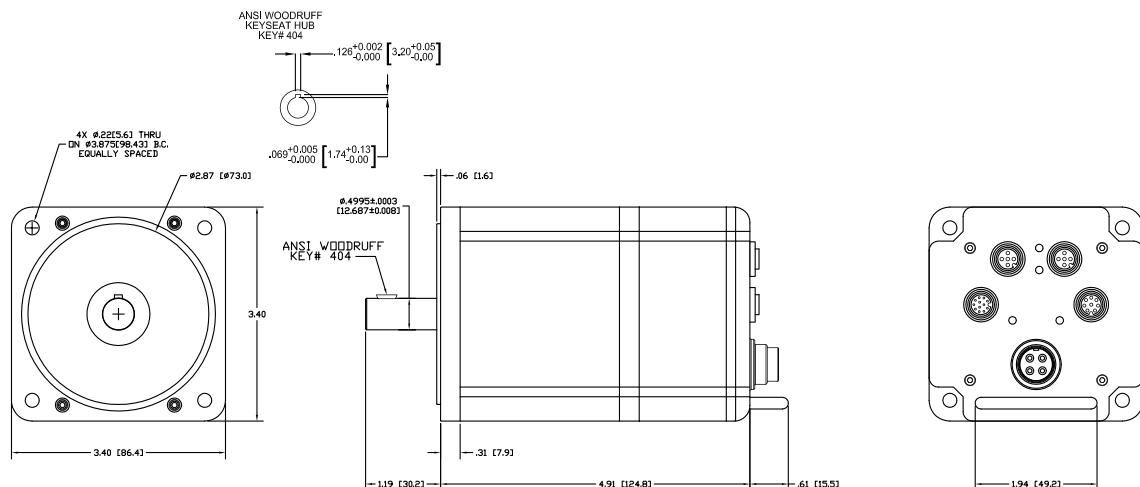

# IP 65 Models

With the release of Animatics' new IP65 rated SM34165MT-IP SmartMotor™, a wealth of new application possibilities have been exposed. This is the first harsh environment-rated product from Animatics, and the quality and durability of the SmartMotor integrated servo in combination with an IP65 rating (and an option for an IP67 rating) has added tremendous value to an already strong product series.



For the IP65 rated SmartMotor, not only is it completely dust tight but it's also protected from ingress of liquid that may occur from any angle, rendering no effect on the electrical enclosure. The SM34165MT-IP can withstand splashing water, oil or food debris as well as rainy conditions. Conditions with high levels of humidity and condensation that normally would deter a SmartMotor are no longer a problem. This makes the SM34165MT-IP with the IP65 rating the perfect integrated servo for food and beverage manufacturing and packaging, rugged outdoor conditions, as well as any wet processing environment.

In addition, the SM34165MT-IP has the option for upgrade to an IP67 rating. These products provide the same level of dust and particulate protection, with the added advantage of being submersible in water or other non-hazardous liquid

up to one meter deep for up to 30 minutes. From naval applications to watercraft to medical research, applications are endless for an IP65 and IP67 SmartMotor.

IP ratings are in accordance with the code defined in international standard IEC 60529. Instead of the vague descriptions of "waterproof", "water-resistant" or "dust-proof", the IP rating system provides a uniform, quantifiable set of standard to which each product is rigorously tested. The IP code refers to the degree of protection for the electrical enclosures on a machine against liquid, solid objects and particulates. The first number following "IP" refers to the level of protection of the hazardous parts and electrical enclosures against solid objects and particulates, and the second digit indicates the level of water resistance. The higher the first digit rating in the IP system, the smaller the foreign object that it is protected against. The SM34165MT is IP65 rated (with the option for IP67) and thus has the highest possible protection from solid matter: it is completely dust-tight. With this rating, any wood, concrete, wheat or grain, plaster or other material processing applications usually resulting in fine byproduct are completely accessible with the SM34165MT-IP.



## Torque Curve

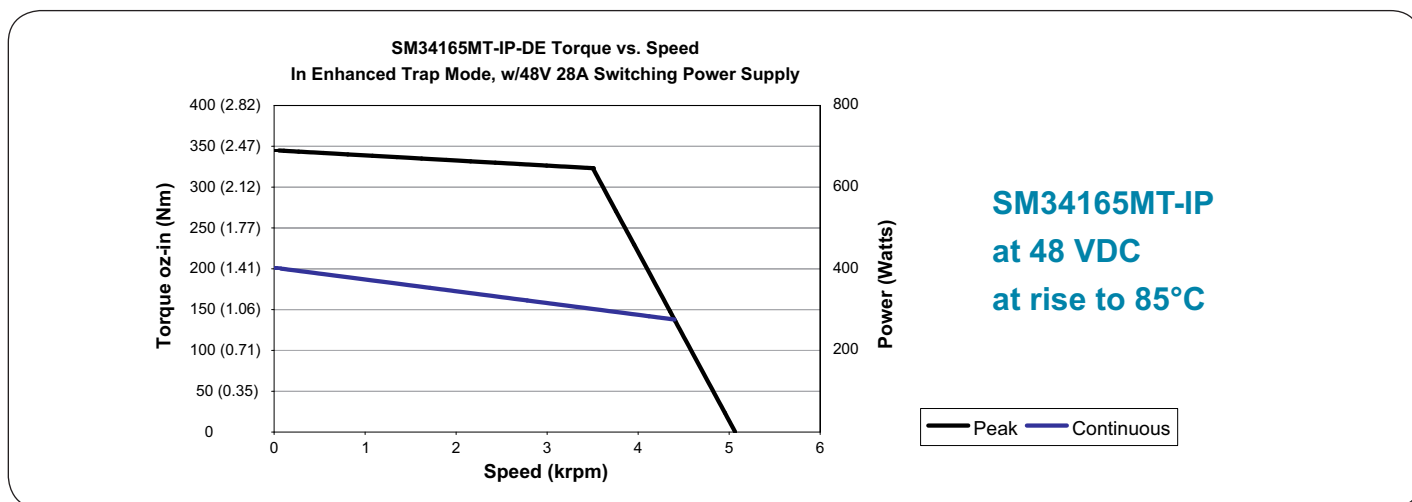

All torque curves were derived under dynamometer testing at an ambient temperature of 25°C with a heat rise of level shown for continuous curves. These are maximum values obtained for dyno tested torques as shown in the catalog which can be found at [www.animatics.com](http://www.animatics.com).

Consult Factory or your nearest Automation Solution Provider (ASP) for Manual, Software and Accessories.

