

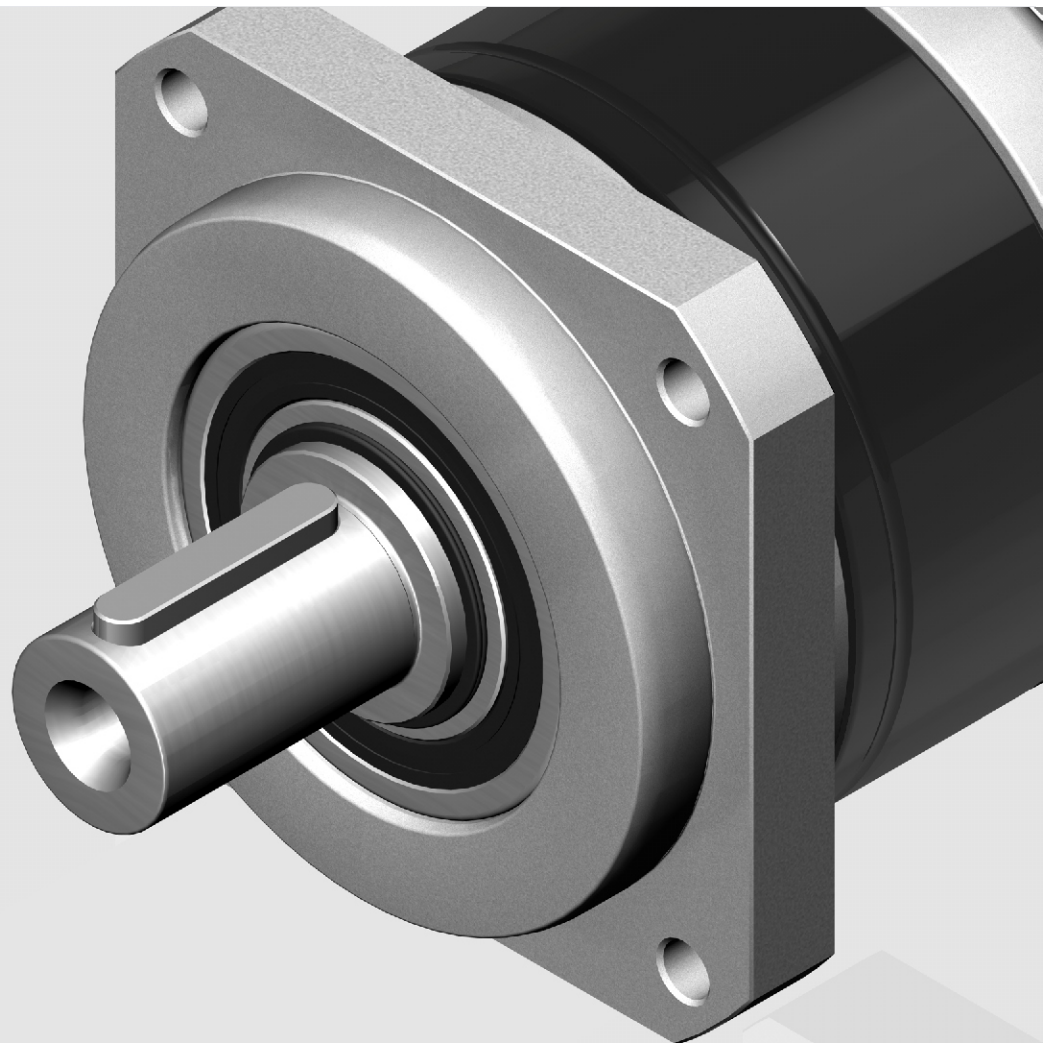

APEX DYNAMICS, INC.

PAII - SERIES
PLANETARY GEARBOX
NEW GENERATION

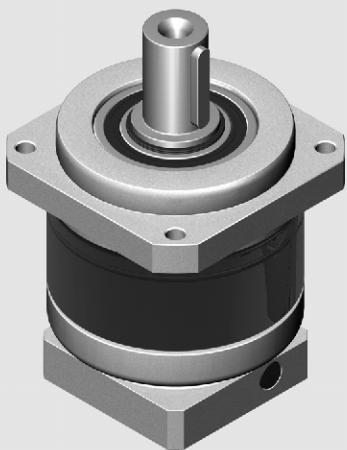

PAII Series

► Features:

Economic
High efficiency
Low noise
Reduced backlash
Optimized Inertia moment
Limited temperature rise
Long service life
Flexible mounting diameters
Minimized size and weight

Your motor's perfect match!!

The brand new APEX PII series. The PII series is an economic high precision planetary gearbox with excellent performance and quality. Our innovative PII series design features minimal size, light weight and high efficiency.

► Ordering Code

PAII090	—	010 — ⁽²⁾	/	MOTOR
				Motor Designation: Manufacture Type And Model
				Ratio⁽¹⁾: 1 stage: 3, 4, 5, 7, 10 2 stage: 15, 16, 20, 25, 30, 35, 40, 50, 70, 100
Gear Size: PSII : PSII A, PSII B, PSII C, PSII D, PSII E				

Ordering Example : PAII 090-010 / SIEMENS 1FT6 041-4AF71
PAII 090-010-S1 / SIEMENS 1FT6 041-4AF71

(1) Other ratios are available, please contact APEX.

(2) For PSII, PEII and PGII series, the output shaft with key (S2) is standard.
For PAII series, the S1 and S2 are both available.

Permitted Radial And Axial Loads On Output Shaft

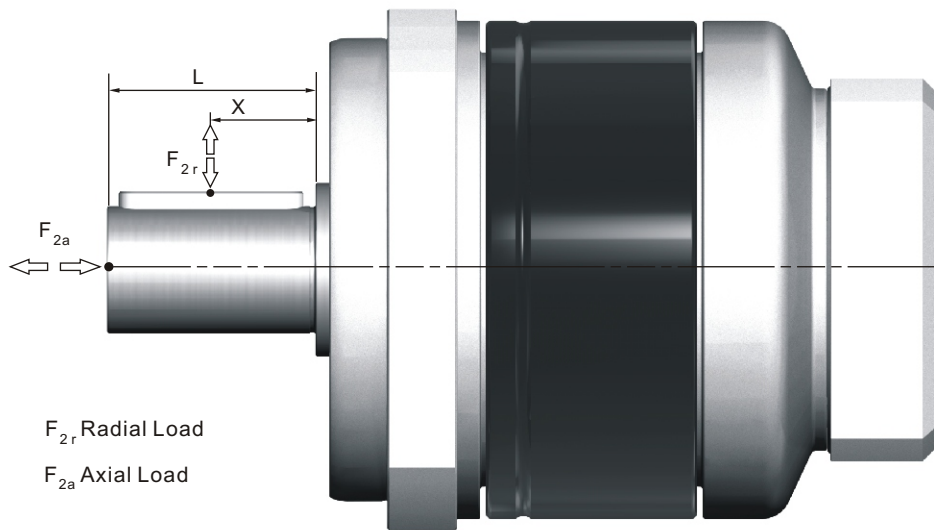

The permitted radial and axial loads on output shaft of the gearbox depend on the design of the gearbox supporting bearings.

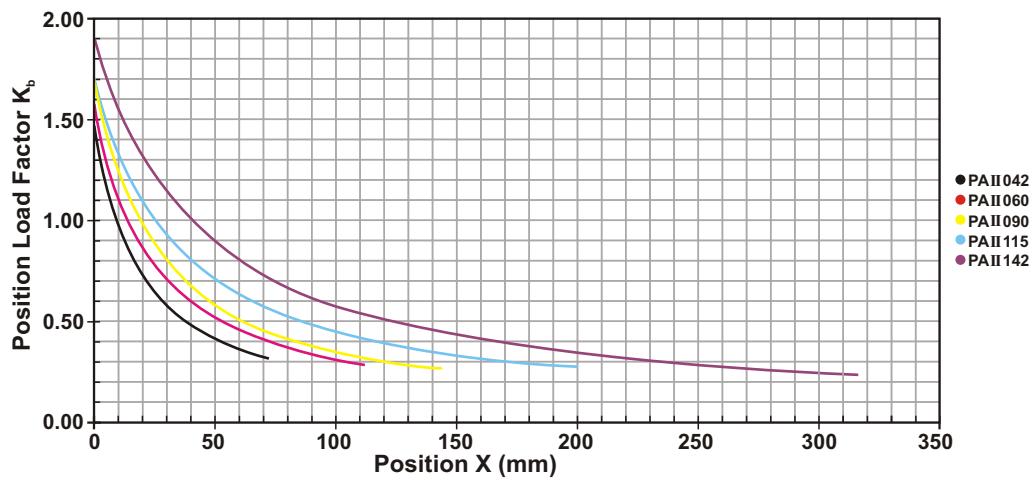

If radial force F_r is not exerted on the center of the output shaft $X < 1/2xL$ or $X > 1/2xL$, the permitted radial and axial loads can be calculated by the position load factor K_b on the above diagram.

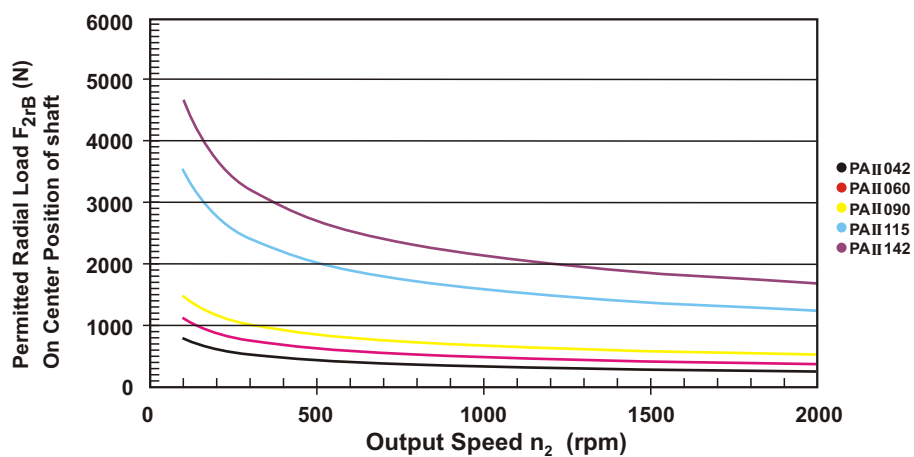

Permitted radial load F_r on center of output shaft $X = 1/2 \times L$ for various output speeds. Values provided are for 20,000 hours^(*) life.

(*) For Continuous Operation(S1), the service life reduced to 50%.

PAII Series Specifications

PAII042		1-stage						2-stage										
		Ratio ^{(1) (2)}						Ratio ^{(1) (2)}										
		3	4	5	7	9	10	15	16	20	25	30	35	40	50	70	81	100
Nominal Output Torque T_{2N}	Nm	4.4	6.1	5.9	5.4	4.7	5.3	4.3	5.9	5.9	6.2	4.3	5.8	5.8	6.1	5.8	5	5.7
Emergency Stop Torque T_{2NOT}	Nm	3 times T_{2N}																
Max. Acceleration Torque T_{2B}	Nm	7.9	11	10.6	9.7	8.5	9.5	7.7	10.6	10.6	11.2	7.7	10.4	10.4	11	10.4	9	10.3
No Load Running Torque ⁽⁸⁾	Nm	0.05						0.05										
Backlash ⁽³⁾	arcmin	≤ 7						≤ 9										
Torsional Rigidity	Nm/arcmin	0.9						0.9										
Nominal Input Speed n_{1N}	rpm	4,500																
Max. Input Speed n_{1B}	rpm	8,000																
Max. Radial Load F_{2rB} ⁽⁴⁾	N	840																
Max. Axial Load F_{2aB} ⁽⁴⁾	N	420																
Service Life ⁽⁷⁾	hr	20,000																
Operating Temperature	°C	0° C~ +90° C																
Lubrication		Synthetic lubrication grease																
Mounting Position		All directions																
Running Noise ^{(6) (8)}	dB(A)	≤ 60						≤ 60										
Efficiency η	%	$\geq 97\%$						$\geq 94\%$										
Weight	kg	$\emptyset^{(5)} \leq 8, 11, 14 = 0.7$						$\emptyset^{(5)} \leq 8, 11, 14 = 0.8$										
Moment of Inertia J_1	kg.cm ²	$\emptyset^{(5)} \leq 8$	0.11	0.10	0.10	0.10	0.10	0.10	0.10	0.10	0.10	0.10	0.10	0.10	0.10	0.10	0.10	0.10
		$\emptyset^{(5)} \leq 11$	0.17	0.16	0.16	0.16	0.16	0.16	0.16	0.16	0.16	0.16	0.16	0.16	0.16	0.16	0.16	0.16
		$\emptyset^{(5)} \leq 14$	0.20	0.20	0.20	0.20	0.20	0.20	0.20	0.20	0.20	0.20	0.20	0.20	0.20	0.20	0.20	0.20

(1) Ratio ($i = N_{in} / N_{out}$).

(2) Other ratios are available, please contact APEX.

(3) Backlash is measured at 2% of Nominal Output Torque T_{2N} .

(4) Applied to the output shaft center at 100 rpm.

(5) \emptyset = Input shaft diameter.

(6) These values are measured at 3000 rpm without load.

(7) For continuous operation, the service life is 10000 hrs.

(8) These values are measured with ratio=10 (1-stage) and ratio=100 (2-stage) at 3000 rpm.

PAII Series Dimension

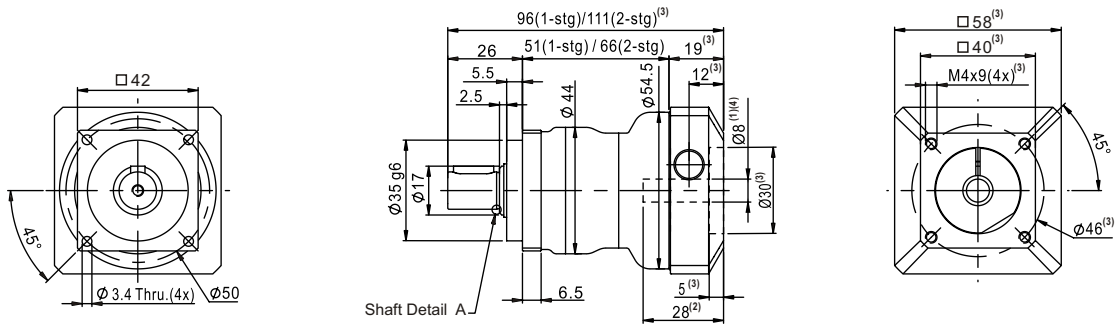

Ø⁽⁵⁾ ≦ 8

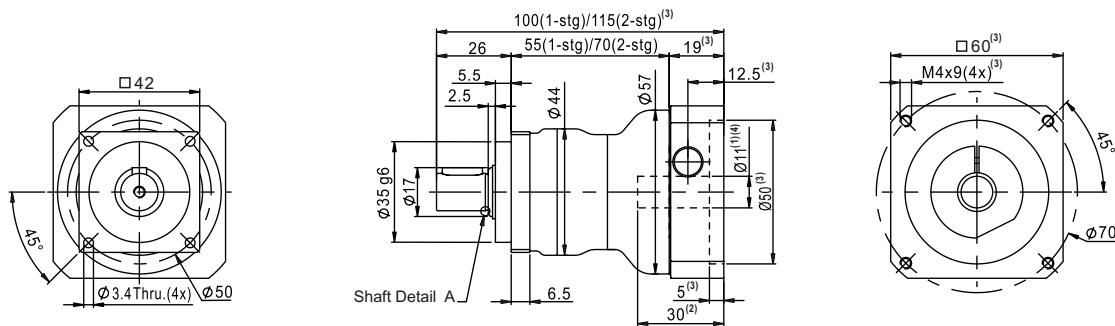

Ø⁽⁵⁾ ≦ 11

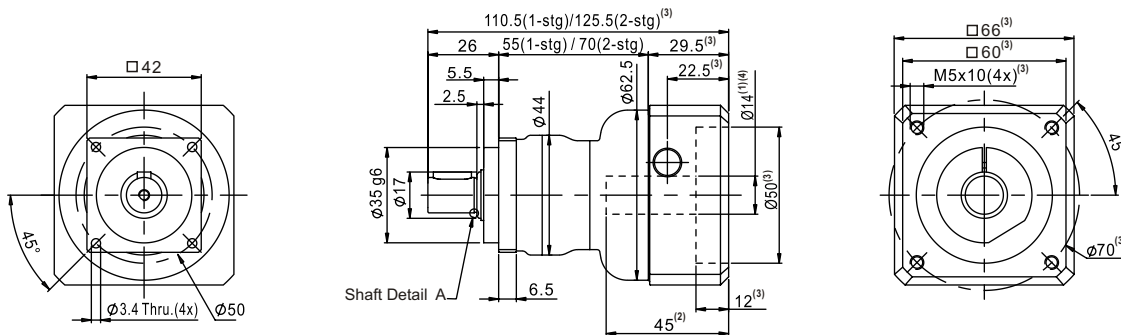

Ø⁽⁵⁾ ≦ 14

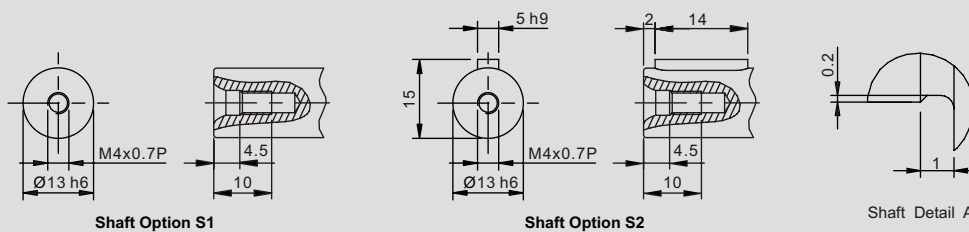

Shaft Detail

- (1) This dimension refers to motor shaft diameter.
- (2) The maximum motor shaft length. For other Motor specific dimensions, please contact APEX.
- (3) Input dimensions vary according to motor flange.
- (4) Please contact APEX, if there is no proper dimension.
- (5) Ø= Input shaft diameter.

PAII Series Specifications

PAII060		1-stage						2-stage												
		Ratio ^{(1) (2)}						Ratio ^{(1) (2)}												
		3	4	5	7	9	10	15	16	20	25	30	35	40	50	70	81	100		
Nominal Output Torque T_{2N}	Nm	15	21	19.5	18	15.3	17.7	14.5	20	20	21	14	19.3	19.2	20	19.6	16.4	18.8		
Emergency Stop Torque T_{2NOT}	Nm	3 times T_{2N}																		
Max. Acceleration Torque T_{2B}	Nm	27	37.8	35.1	32.4	27.5	31.9	26.1	36	36	37.8	25	34.7	34.6	36	35.3	29.5	33.8		
No Load Running Torque ⁽⁶⁾	Nm	0.1						0.1												
Backlash ⁽³⁾	arcmin	≤ 6						≤ 8												
Torsional Rigidity	Nm/arcmin	2.2						2.2												
Nominal Input Speed n_{1N}	rpm	4,000																		
Max. Input Speed n_{1B}	rpm	6,000																		
Max. Radial Load F_{2rB} ⁽⁴⁾	N	1,290																		
Max. Axial Load F_{2aB} ⁽⁴⁾	N	645																		
Service Life ⁽⁷⁾	hr	20,000																		
Operating Temperature	°C	0° C~ +90° C																		
Lubrication		Synthetic lubrication grease																		
Mounting Position		All directions																		
Running Noise ^{(6) (8)}	dB(A)	≤ 62						≤ 62												
Efficiency η	%	$\geq 97\%$						$\geq 94\%$												
Weight	kg	$\emptyset^{(5)} \leq 8, 11, 14 = 1$ $\emptyset^{(5)} \leq 19 = 1.9$						$\emptyset^{(5)} \leq 8, 11, 14 = 1.5$ $\emptyset^{(5)} \leq 19 = 2.2$												
Moment of Inertia J_1	kg.cm ²	$\emptyset^{(5)} \leq 8$	0.13	0.11	0.10	0.10	0.10	0.10	0.10	0.11	0.10	0.10	0.10	0.10	0.10	0.10	0.10	0.10	0.10	
		$\emptyset^{(5)} \leq 11$	0.19	0.17	0.17	0.17	0.17	0.17	0.17	0.17	0.17	0.17	0.17	0.17	0.17	0.17	0.17	0.17	0.17	0.17
		$\emptyset^{(5)} \leq 14$	0.25	0.23	0.22	0.22	0.22	0.22	0.22	0.22	0.23	0.22	0.22	0.22	0.22	0.22	0.22	0.22	0.22	0.22
		$\emptyset^{(5)} \leq 19$	1.54	1.52	1.52	1.51	1.51	1.51	1.52	1.52	1.52	1.52	1.52	1.51	1.52	1.51	1.51	1.51	1.51	1.51

(1) Ratio ($i = N_{in} / N_{out}$).

(2) Other ratios are available, please contact APEX.

(3) Backlash is measured at 2% of Nominal Output Torque T_{2N} .

(4) Applied to the output shaft center at 100 rpm.

(5) \emptyset = Input shaft diameter.

(6) These values are measured at 3000 rpm without load.

(7) For continuous operation, the service life is 10000 hrs.

(8) These values are measured with ratio=10 (1-stage) and ratio=100 (2-stage) at 3000 rpm.

PAII Series Dimension

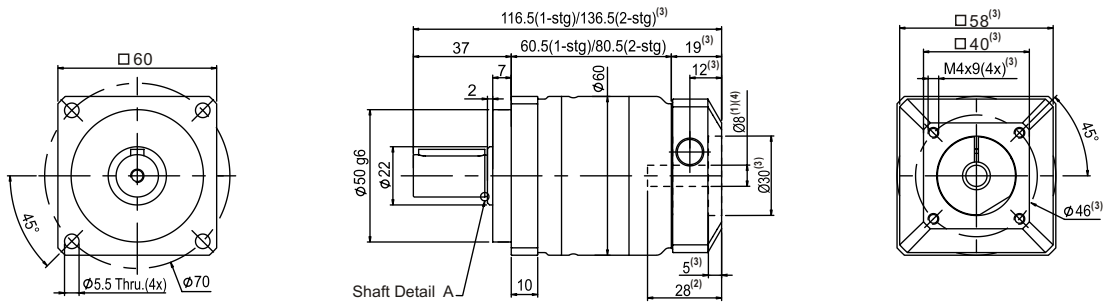

Ø⁽⁵⁾ ≤ 8

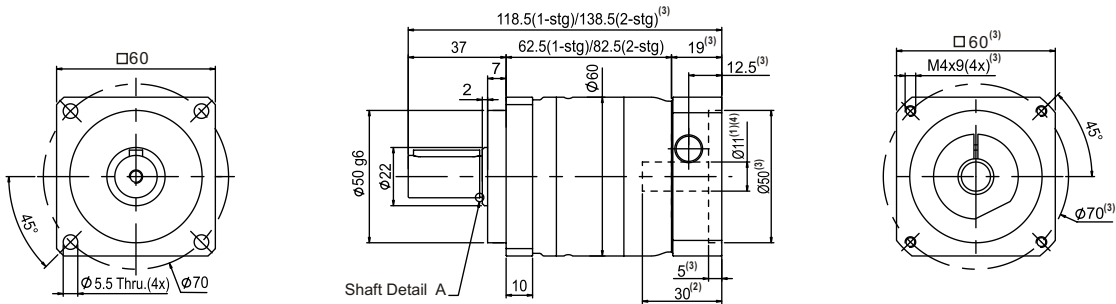

Ø⁽⁵⁾ ≤ 11

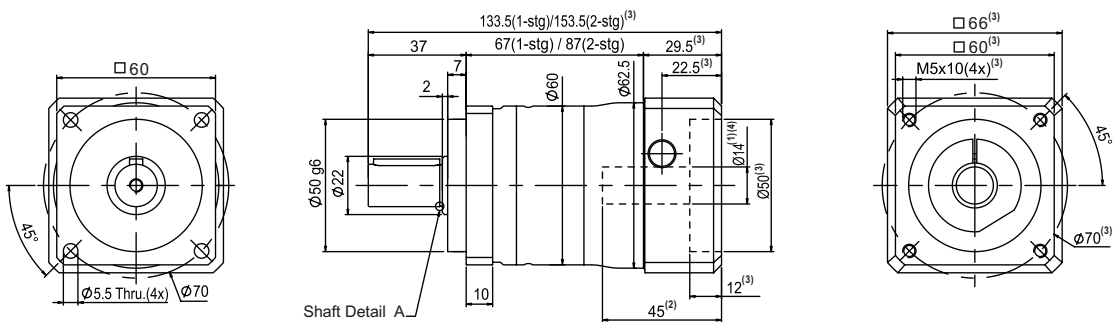

Ø⁽⁵⁾ ≤ 14

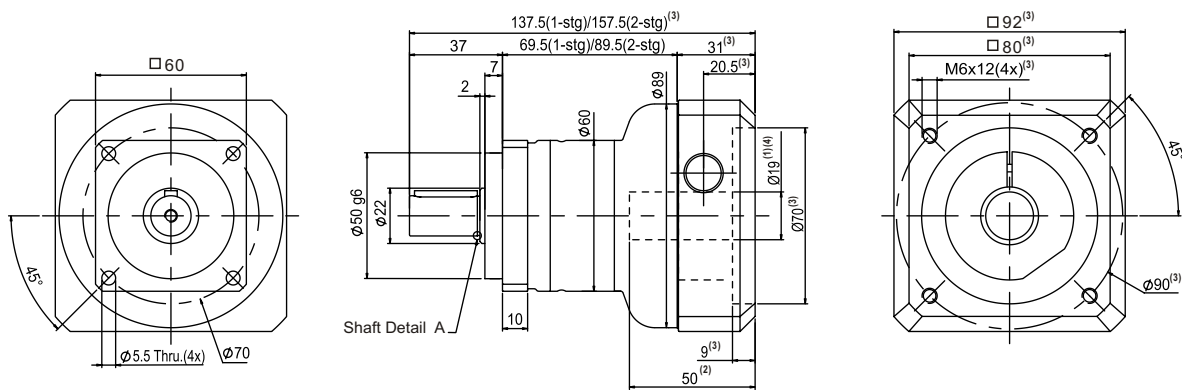

Ø⁽⁵⁾ ≤ 19

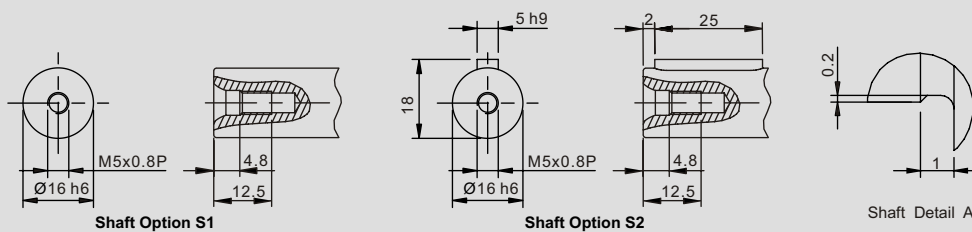

Shaft Detail

- (1) This dimension refers to motor shaft diameter.
- (2) The maximum motor shaft length. For other Motor specific dimensions, please contact APEX.
- (3) Input dimensions vary according to motor flange.
- (4) Please contact APEX, if there is no proper dimension.
- (5) Ø= Input shaft diameter.

PAII Series Specifications

PAII090		1-stage						2-stage											
		Ratio ^{(1) (2)}						Ratio ^{(1) (2)}											
		3	4	5	7	9	10	15	16	20	25	30	35	40	50	70	81	100	
Nominal Output Torque T_{2N}	Nm	33	46	48	49	41	46	32	44	44	46	32	54	43	45	54	41	48	
Emergency Stop Torque T_{2NOT}	Nm	3 times T_{2N}																	
Max. Acceleration Torque T_{2B}	Nm	59.4	82.8	86.4	88.2	73.8	82.8	57.6	79.2	79.2	82.8	57.6	97.2	77.4	81	97.2	73.8	86.4	
No Load Running Torque ⁽⁸⁾	Nm	0.4						0.3											
Backlash ⁽³⁾	arcmin	≤ 5						≤ 7											
Torsional Rigidity	Nm/arcmin	8						8											
Nominal Input Speed n_{1N}	rpm	3,600																	
Max. Input Speed n_{1B}	rpm	6,000																	
Max. Radial Load F_{2rB} ⁽⁴⁾	N	1,510																	
Max. Axial Load F_{2aB} ⁽⁴⁾	N	755																	
Service Life ⁽⁷⁾	hr	20,000																	
Operating Temperature	°C	0° C~ +90° C																	
Lubrication		Synthetic lubrication grease																	
Mounting Position		All directions																	
Running Noise ^{(6) (8)}	dB(A)	≤ 64						≤ 64											
Efficiency η	%	$\geq 97\%$						$\geq 94\%$											
Weight	kg	$\varnothing^{(5)} \leq 14 = 2.5$ $\varnothing^{(5)} \leq 19, 24, 28 = 3.5$						$\varnothing^{(5)} \leq 14 = 3.4$ $\varnothing^{(5)} \leq 19, 24, 28 = 4.4$											
Moment of Inertia J_1	kg.cm ²	$\varnothing^{(5)} \leq 14$	0.38	0.27	0.25	0.24	0.24	0.24	0.25	0.27	0.25	0.25	0.24	0.25	0.24	0.24	0.24	0.24	0.24
		$\varnothing^{(5)} \leq 19$	1.77	1.66	1.64	1.63	1.63	1.63	1.64	1.66	1.64	1.64	1.63	1.64	1.63	1.63	1.63	1.63	1.63
		$\varnothing^{(5)} \leq 24$	2.33	2.22	2.20	2.19	2.19	2.19	2.20	2.22	2.20	2.20	2.19	2.20	2.19	2.19	2.19	2.19	2.19
		$\varnothing^{(5)} \leq 28$	2.86	2.75	2.73	2.72	2.71	2.71	2.73	2.75	2.73	2.73	2.71	2.73	2.71	2.71	2.71	2.71	2.71

(1) Ratio ($i = N_{in} / N_{out}$).
 (2) Other ratios are available, please contact APEX.
 (3) Backlash is measured at 2% of Nominal Output Torque T_{2N} .
 (4) Applied to the output shaft center at 100 rpm.
 (5) \varnothing = Input shaft diameter.
 (6) These values are measured at 3000 rpm without load.
 (7) For continuous operation, the service life is 10000 hrs.
 (8) These values are measured with ratio=10 (1-stage) and ratio=100 (2-stage) at 3000 rpm.

PAII Series Dimension

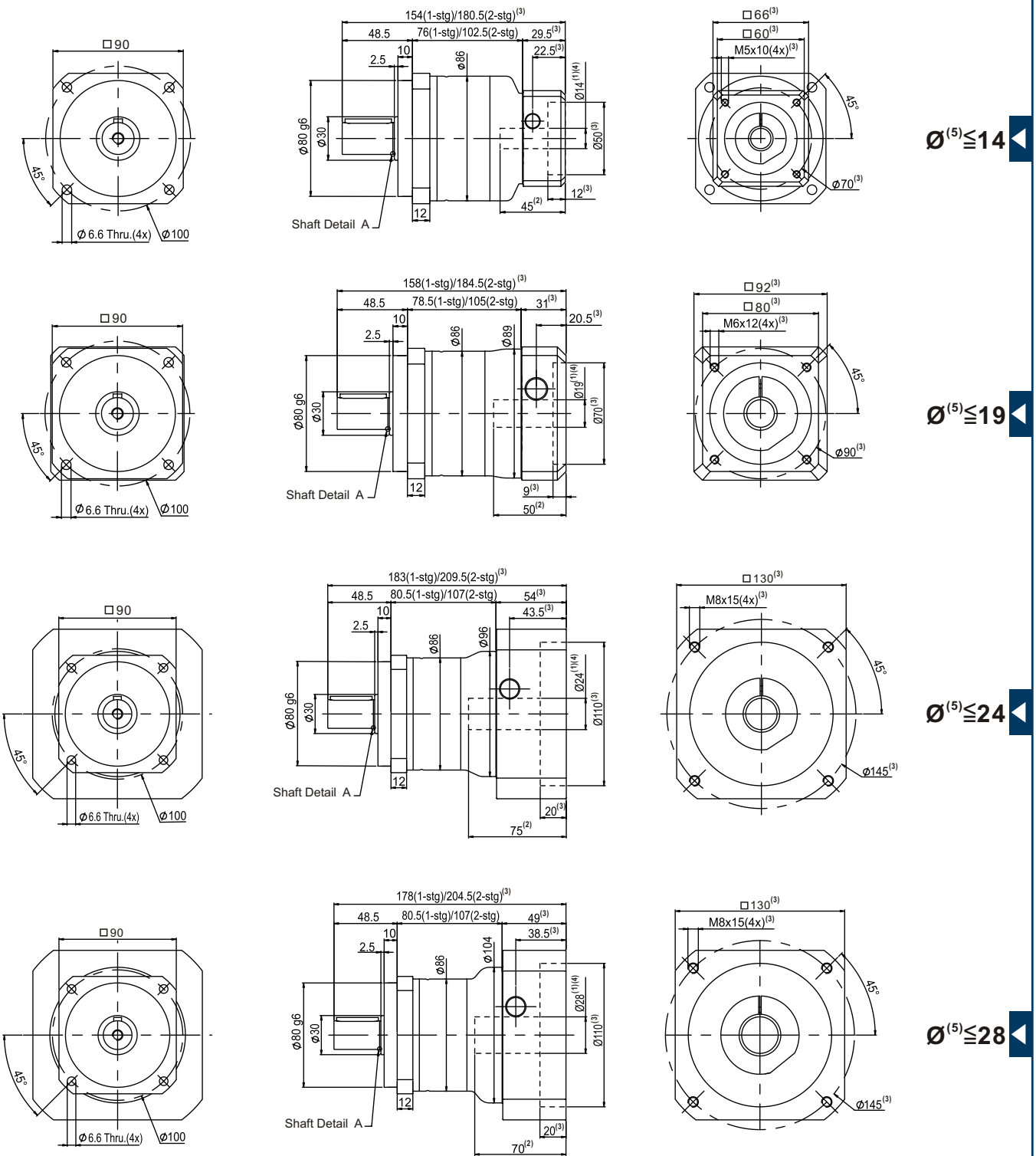

$\phi^{(5)} \leq 14$

$\phi^{(5)} \leq 19$

$\phi^{(5)} \leq 24$

$\phi^{(5)} \leq 28$

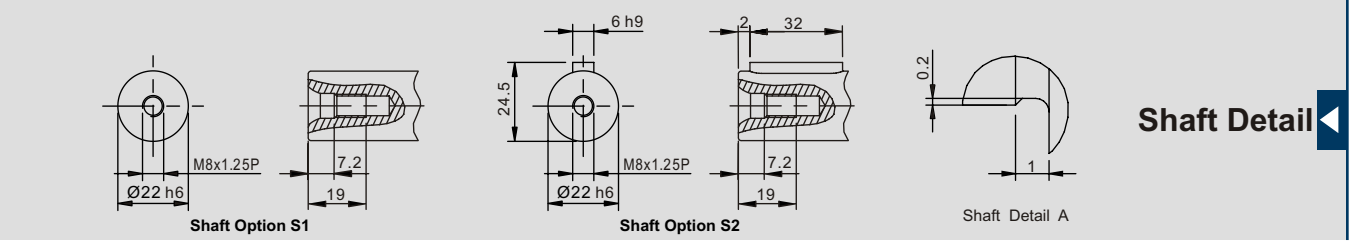

Shaft Detail

- (1) This dimension refers to motor shaft diameter.
- (2) The maximum motor shaft length. For other Motor specific dimensions, please contact APEX.
- (3) Input dimensions vary according to motor flange.
- (4) Please contact APEX, if there is no proper dimension.
- (5) ϕ = Input shaft diameter.

PAII Series Specifications

PAII115		1-stage						2-stage											
		Ratio ^{(1) (2)}						Ratio ^{(1) (2)}											
		3	4	5	7	9	10	15	16	20	25	30	35	40	50	70	81	100	
Nominal Output Torque T _{2N}	Nm	51	72	76	91	66	74	50	70	70	73	50	88	68	71	86	67.5	77	
Emergency Stop Torque T _{2NOT}	Nm	3 times T _{2N}																	
Max. Acceleration Torque T _{2B}	Nm	91.8	130	137	164	119	133	90	126	126	131	90	158	122	128	155	122	139	
No Load Running Torque ⁽⁸⁾	Nm	0.8						0.4											
Backlash ⁽³⁾	arcmin	≤ 5						≤ 7											
Torsional Rigidity	Nm/arcmin	12						12											
Nominal Input Speed n _{1N}	rpm	3,600																	
Max. Input Speed n _{1B}	rpm	4,800																	
Max. Radial Load F _{2rB} ⁽⁴⁾	N	3,780																	
Max. Axial Load F _{2aB} ⁽⁴⁾	N	1,890																	
Service Life ⁽⁷⁾	hr	20,000																	
Operating Temperature	° C	0° C~ +90° C																	
Lubrication		Synthetic lubrication grease																	
Mounting Position		All directions																	
Running Noise ^{(6) (8)}	dB(A)	≤ 66						≤ 66											
Efficiency η	%	≥ 97%						≥ 94%											
Weight	kg	Ø ⁽⁵⁾ ≤ 19, 24, 28= 6.5 Ø ⁽⁵⁾ ≤ 32, 35= 8.1 Ø ⁽⁵⁾ ≤ 38= 12						Ø ⁽⁵⁾ ≤ 19, 24, 28= 8.7 Ø ⁽⁵⁾ ≤ 32, 35= 10.3 Ø ⁽⁵⁾ ≤ 38= 14.2											
Moment of Inertia J ₁	kg.cm ²	Ø ⁽⁵⁾ ≤ 19	2.41	1.96	1.88	1.84	1.83	1.83	1.88	1.96	1.88	1.88	1.83	1.88	1.83	1.83	1.83	1.83	1.83
		Ø ⁽⁵⁾ ≤ 24	3.11	2.66	2.57	2.54	2.53	2.53	2.57	2.66	2.57	2.57	2.53	2.57	2.53	2.53	2.53	2.53	2.53
		Ø ⁽⁵⁾ ≤ 28	3.40	2.96	2.87	2.84	2.83	2.83	2.87	2.96	2.87	2.87	2.83	2.87	2.83	2.83	2.83	2.83	2.83
		Ø ⁽⁵⁾ ≤ 32	8.00	7.55	7.47	7.43	7.42	7.42	7.47	7.55	7.47	7.47	7.42	7.47	7.42	7.42	7.42	7.42	7.42
		Ø ⁽⁵⁾ ≤ 35	10.97	10.52	10.44	10.40	10.39	10.39	10.44	10.52	10.44	10.44	10.39	10.44	10.39	10.39	10.39	10.39	10.39
		Ø ⁽⁵⁾ ≤ 38	14.18	13.73	13.65	13.61	13.60	13.60	13.65	13.73	13.65	13.65	13.60	13.65	13.60	13.60	13.60	13.60	13.60

(1) Ratio (i= N_{in} / N_{out}).
 (2) Other ratios are available, please contact APEX.
 (3) Backlash is measured at 2% of Nominal Output Torque T_{2N}.
 (4) Applied to the output shaft center at 100 rpm.
 (5) Ø = Input shaft diameter.
 (6) These values are measured at 3000 rpm without load.
 (7) For continuous operation, the service life is 10000 hrs.
 (8) These values are measured with ratio=10 (1-stage) and ratio=100 (2-stage) at 3000 rpm.

PAII Series Dimension

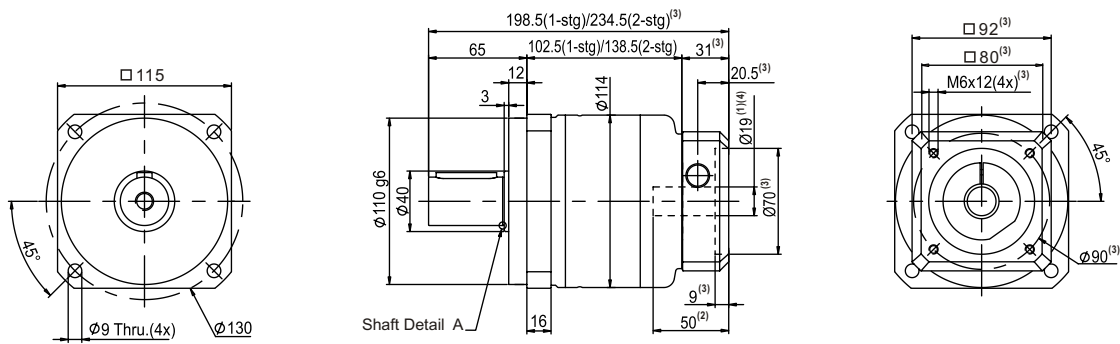

Ø⁽⁵⁾ ≤ 19

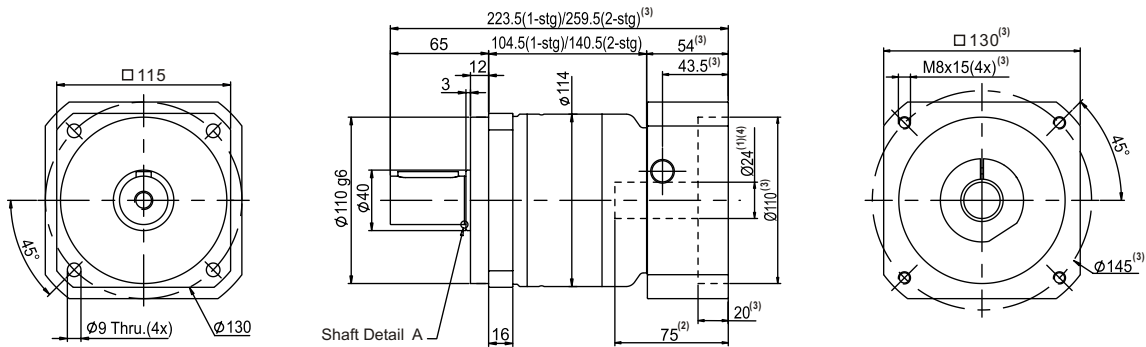

Ø⁽⁵⁾ ≤ 24

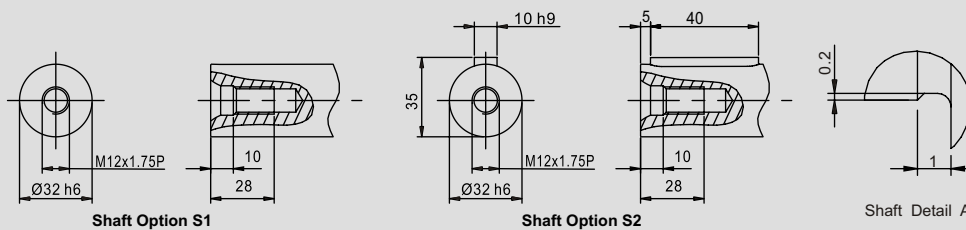

Shaft Detail

- (1) This dimension refers to motor shaft diameter.
- (2) The maximum motor shaft length. For other Motor specific dimensions, please contact APEX.
- (3) Input dimensions vary according to motor flange.
- (4) Please contact APEX, if there is no proper dimension.
- (5) Ø= Input shaft diameter.

PAII Series Dimension

▶ $\varnothing^{(5)} \leq 28$

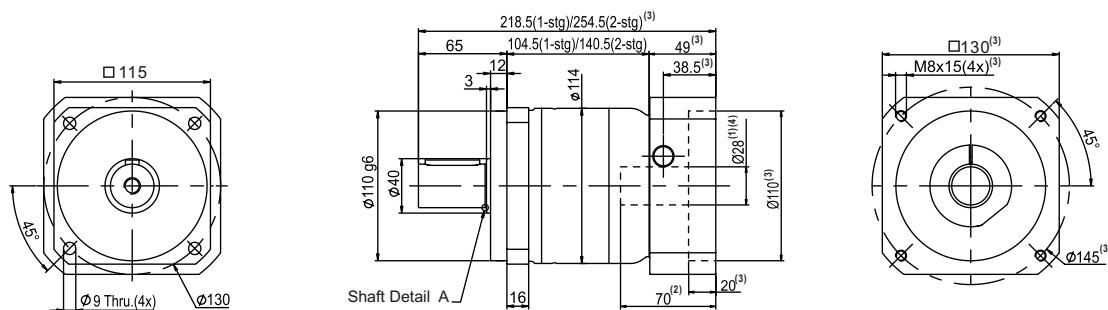

▶ $\varnothing^{(5)} \leq 32$

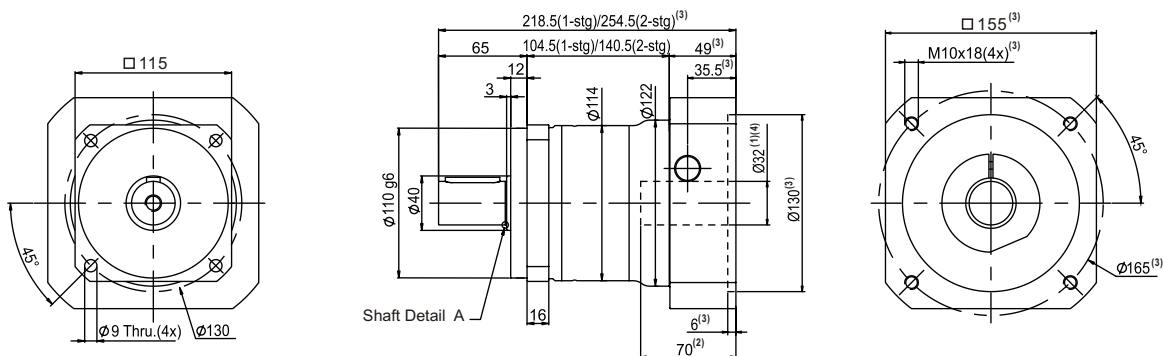

▶ Shaft Detail

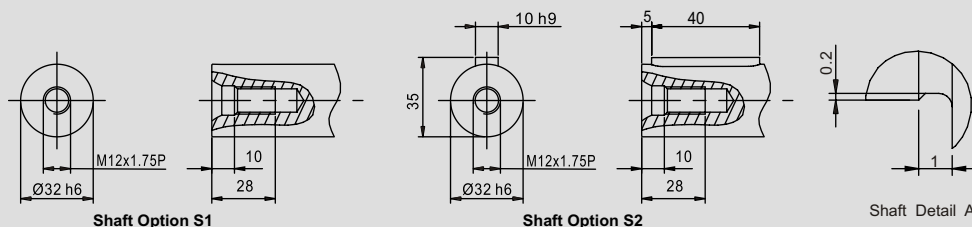

- (1) This dimension refers to motor shaft diameter.
- (2) The maximum motor shaft length. For other Motor specific dimensions, please contact APEX.
- (3) Input dimensions vary according to motor flange.
- (4) Please contact APEX, if there is no proper dimension.
- (5) \varnothing = Input shaft diameter.

PAII Series Dimension

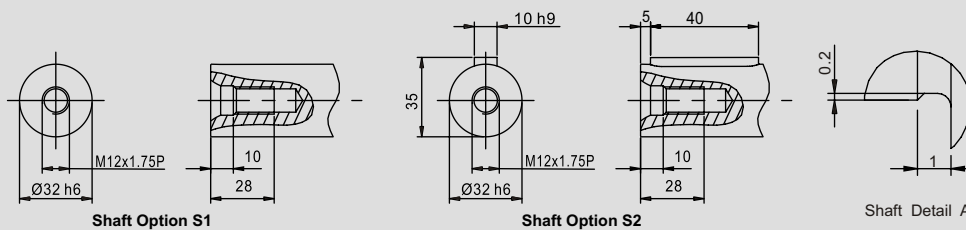
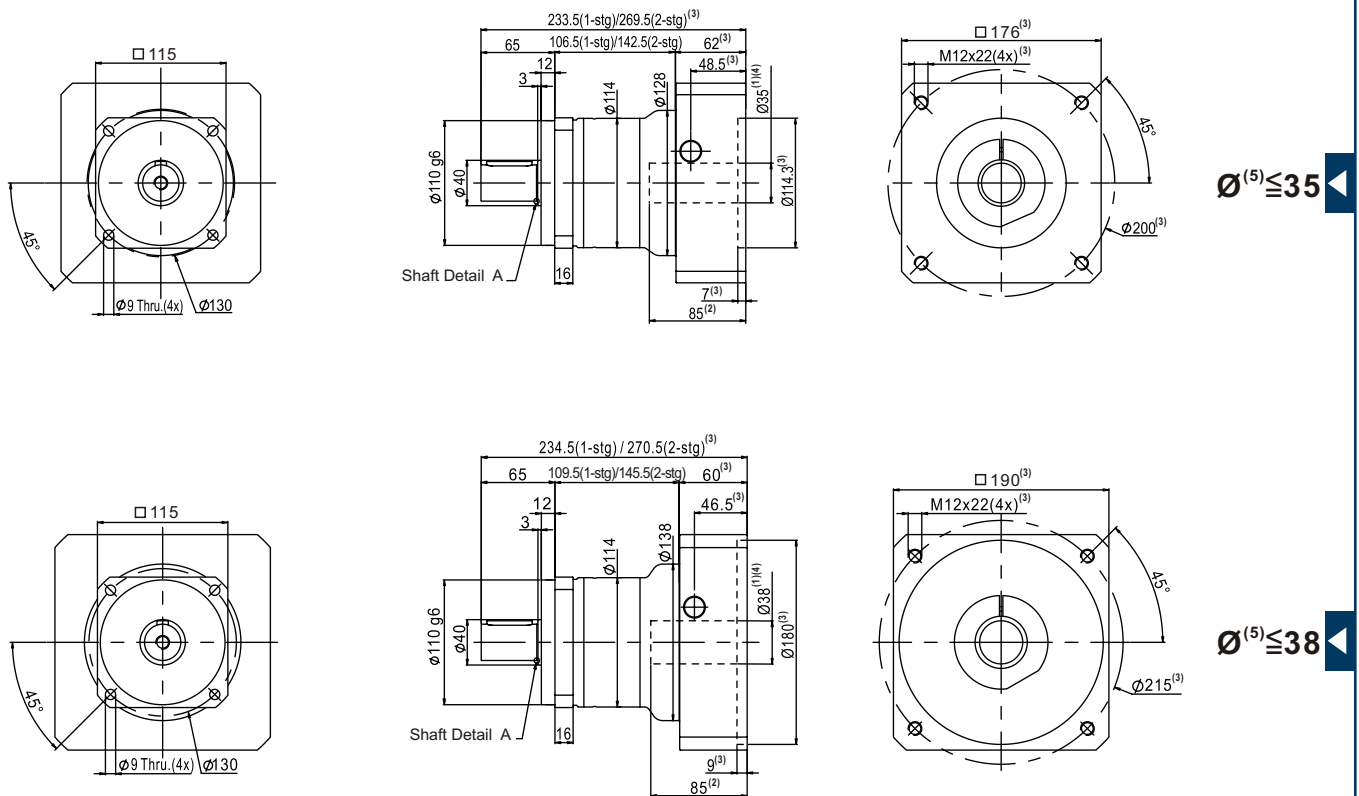

- (1) This dimension refers to motor shaft diameter.
- (2) The maximum motor shaft length. For other Motor specific dimensions, please contact APEX.
- (3) Input dimensions vary according to motor flange.
- (4) Please contact APEX, if there is no proper dimension.
- (5) Ø= Input shaft diameter.

PAII Series Specifications

PAII142		1-stage						2-stage													
		Ratio ^{(1) (2)}						Ratio ^{(1) (2)}													
		3	4	5	7	9	10	15	16	20	25	30	35	40	50	70	81	100			
Nominal Output Torque T_{2N}	Nm	102	143	150	178	126	123	101	140	140	145	99	174	136	140	171	131	128			
Emergency Stop Torque T_{2NOT}	Nm	3 times T_{2N}																			
Max. Acceleration Torque T_{2B}	Nm	184	257	270	320	227	221	182	252	252	261	178	313	245	252	308	235	230			
No Load Running Torque ⁽⁸⁾	Nm	2.5						0.8													
Backlash ⁽³⁾	arcmin	≤ 5						≤ 7													
Torsional Rigidity	Nm/arcmin	16						16													
Nominal Input Speed n_{1N}	rpm	2,500																			
Max. Input Speed n_{1B}	rpm	3,600																			
Max. Radial Load F_{2RB} ⁽⁴⁾	N	4,600																			
Max. Axial Load F_{2aB} ⁽⁴⁾	N	2,300																			
Service Life ⁽⁷⁾	hr	20,000																			
Operating Temperature	°C	0° C~ +90° C																			
Lubrication		Synthetic lubrication grease																			
Mounting Position		All directions																			
Running Noise ^{(6) (8)}	dB(A)	≤ 68						≤ 68													
Efficiency η	%	$\geq 97\%$						$\geq 94\%$													
Weight	kg	$\varnothing^{(5)} \leq 24, 28 = 11.3$ $\varnothing^{(5)} \leq 32, 35 = 12.9$ $\varnothing^{(5)} \leq 38, 42 = 16.8$						$\varnothing^{(5)} \leq 19, 24, 28 = 15.4$ $\varnothing^{(5)} \leq 32, 35 = 17$ $\varnothing^{(5)} \leq 38 = 20.9$													
Moment of Inertia J_1	kg.cm ²	$\varnothing^{(5)} \leq 19$	-	-	-	-	-	-	2.18	2.50	2.18	2.18	2.00	2.18	2.00	2.00	2.00	2.00	2.00		
		$\varnothing^{(5)} \leq 24$	4.80	3.06	2.74	2.60	2.57	2.56	2.74	3.06	2.74	2.74	2.56	2.74	2.56	2.56	2.56	2.56	2.57	2.56	
		$\varnothing^{(5)} \leq 28$	5.22	3.49	3.16	3.02	2.99	2.99	3.16	3.49	3.16	3.16	2.99	3.16	2.99	2.99	2.99	2.99	2.99	2.99	2.99
		$\varnothing^{(5)} \leq 32$	10.74	9.00	8.68	8.53	8.50	8.50	8.68	9.00	8.68	8.68	8.50	8.68	8.50	8.50	8.50	8.50	8.50	8.50	
		$\varnothing^{(5)} \leq 35$	14.14	12.40	12.08	11.93	11.90	11.90	12.08	12.40	12.08	12.08	11.90	12.08	11.90	11.90	11.90	11.90	11.90	11.90	
		$\varnothing^{(7)} \leq 38$	17.20	15.46	15.14	15.00	14.97	14.96	15.14	15.46	15.14	15.14	14.96	15.14	14.96	14.96	14.96	14.96	14.96	14.97	14.96
		$\varnothing^{(7)} \leq 42$	25.85	24.12	23.79	23.65	23.62	23.62	-	-	-	-	-	-	-	-	-	-	-	-	-

(1) Ratio ($i = N_{in} / N_{out}$).

(2) Other ratios are available, please contact APEX.

(3) Backlash is measured at 2% of Nominal Output Torque T_{2N} .

(4) Applied to the output shaft center at 100 rpm.

(5) \varnothing = Input shaft diameter.

(6) These values are measured at 3000 rpm without load.

(7) For continuous operation, the service life is 10000 hrs.

(8) These values are measured with ratio=10 (1-stage) and ratio=100 (2-stage) at 3000 rpm.

PAII Series Dimension

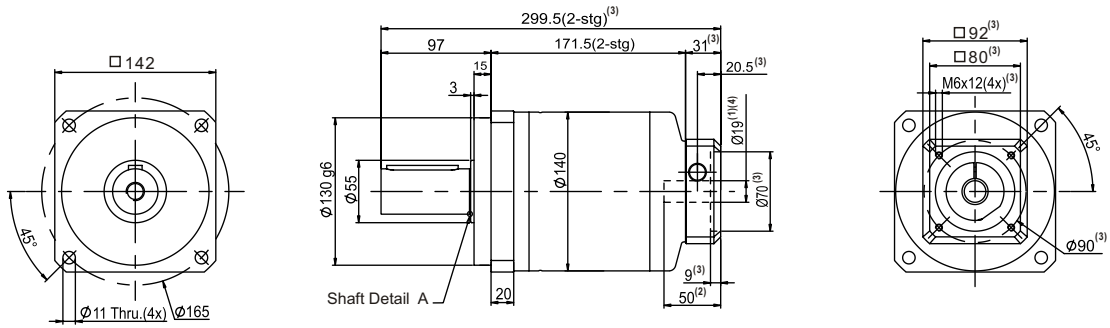

Ø⁽⁵⁾ ≤ 19

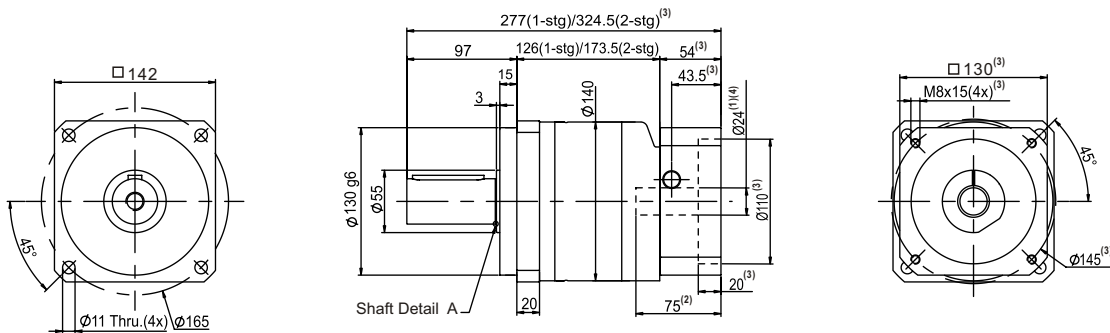

Ø⁽⁵⁾ ≤ 24

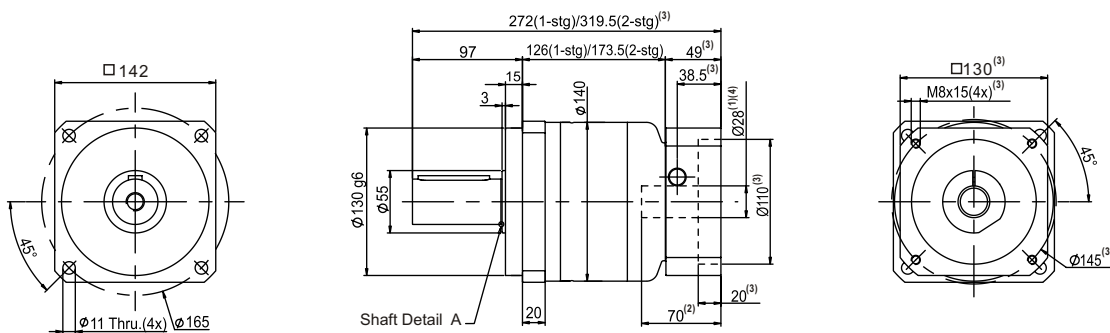

Ø⁽⁵⁾ ≤ 28

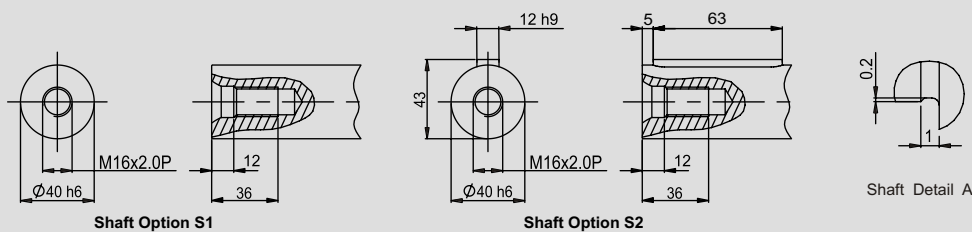

Shaft Detail

- (1) This dimension refers to motor shaft diameter.
- (2) The maximum motor shaft length. For other Motor specific dimensions, please contact APEX.
- (3) Input dimensions vary according to motor flange.
- (4) Please contact APEX, if there is no proper dimension.
- (5) Ø= Input shaft diameter.

PAII Series Dimension

▶ $\varnothing^{(5)} \leq 32$

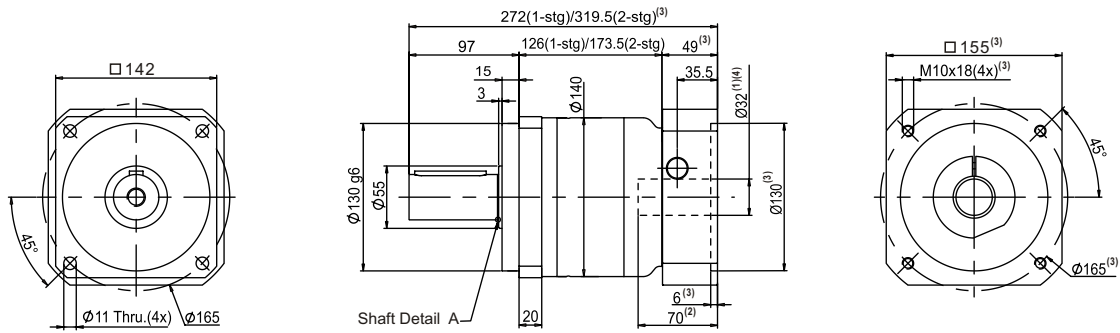

▶ $\varnothing^{(5)} \leq 35$

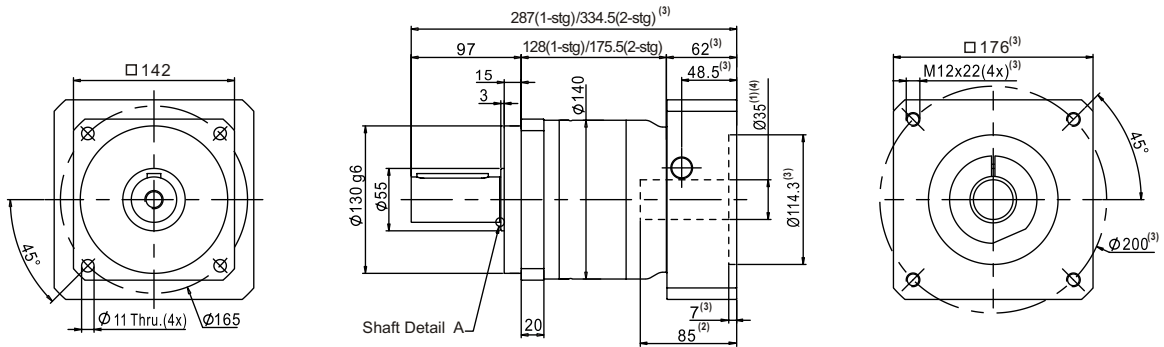

▶ Shaft Detail

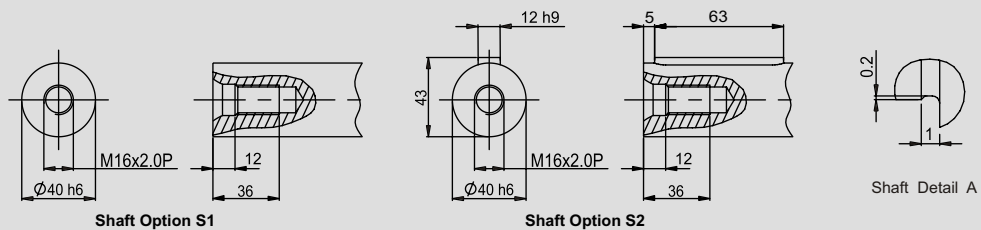

- (1) This dimension refers to motor shaft diameter.
- (2) The maximum motor shaft length. For other Motor specific dimensions, please contact APEX.
- (3) Input dimensions vary according to motor flange.
- (4) Please contact APEX, if there is no proper dimension.
- (5) \varnothing = Input shaft diameter.

PAII Series Dimension

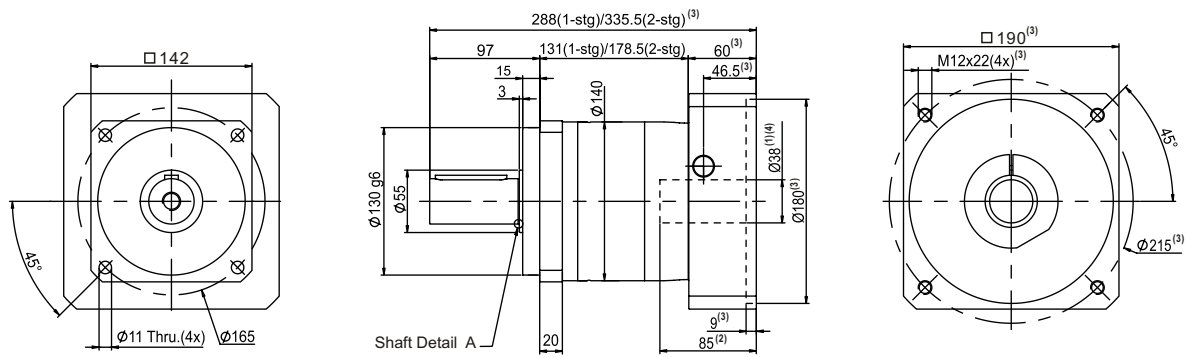

Ø⁽⁵⁾ ≤ 38

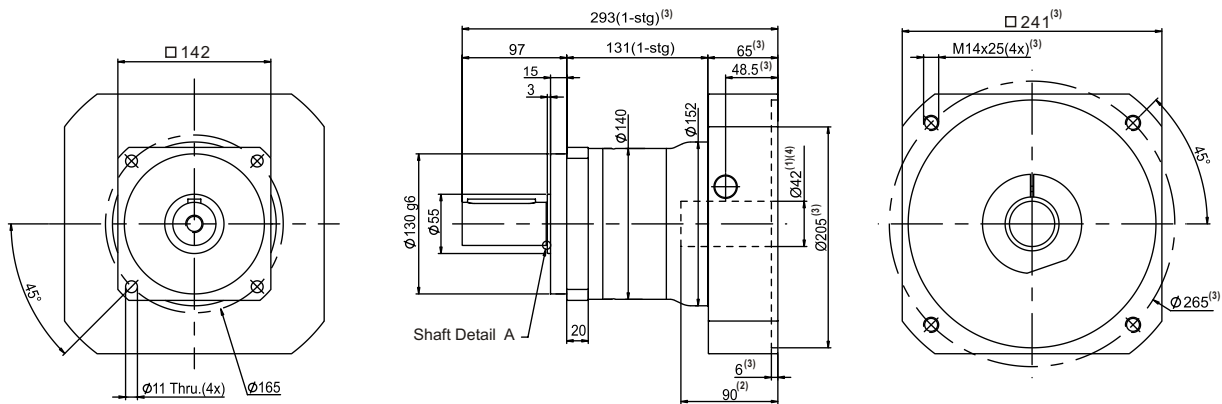

Ø⁽⁵⁾ ≤ 42

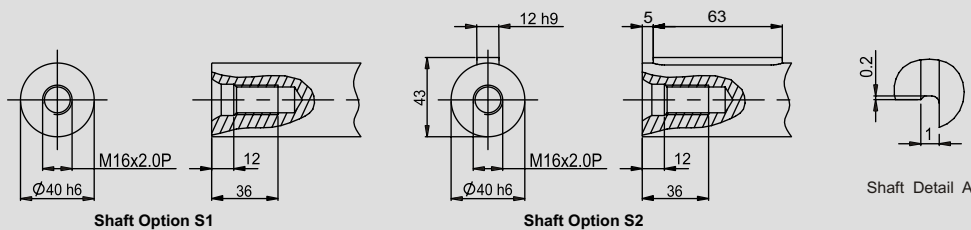

Shaft Detail

- (1) This dimension refers to motor shaft diameter.
- (2) The maximum motor shaft length. For other Motor specific dimensions, please contact APEX.
- (3) Input dimensions vary according to motor flange.
- (4) Please contact APEX, if there is no proper dimension.
- (5) Ø= Input shaft diameter.

Selection of the optimum gearbox

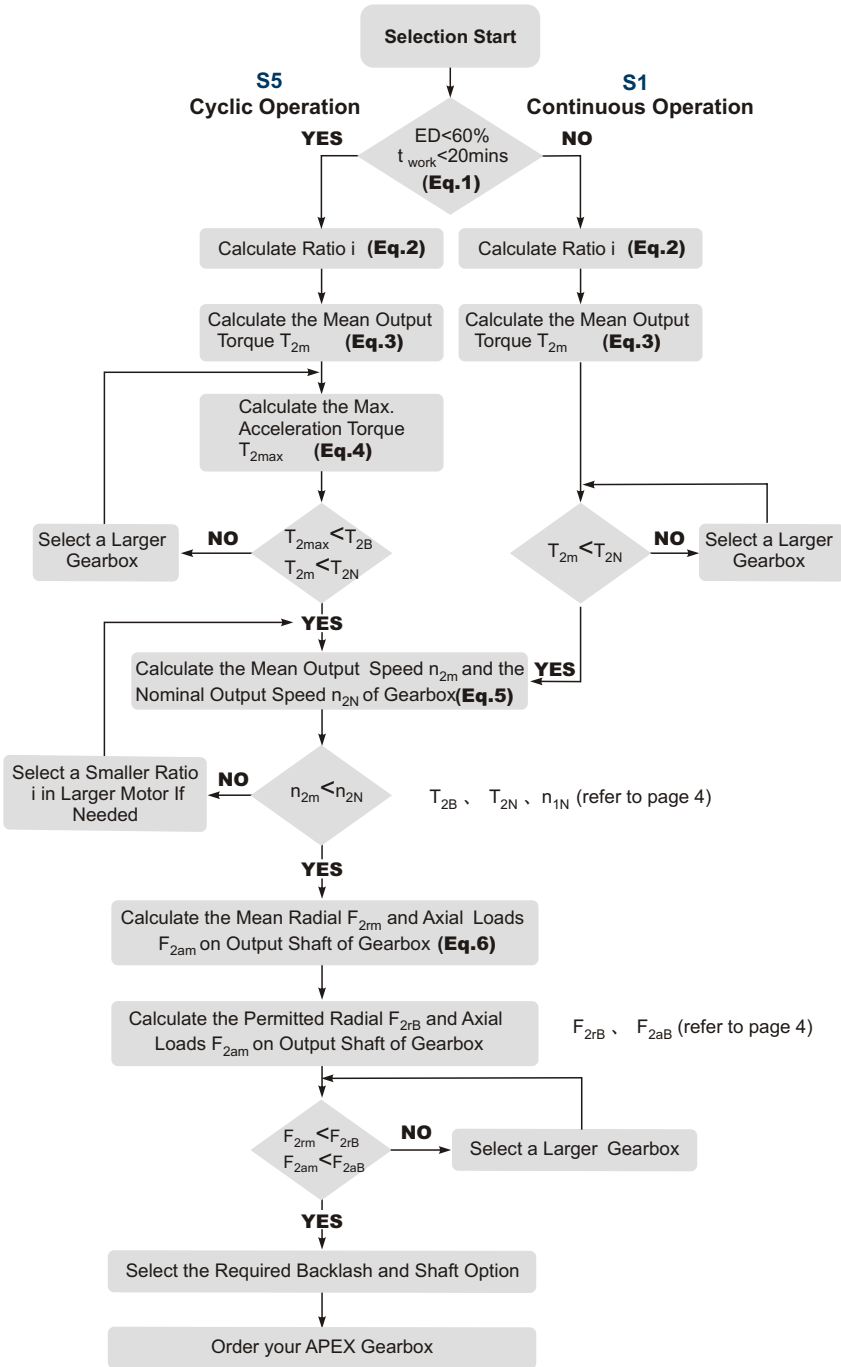

Recommended (for S5 Cycle Operation)

The general design is given for

$$\frac{J_L}{i^2} \leq 4 \times J_m$$

The optimal design is given for

J_L Load Inertia
 J_m Motor Inertia

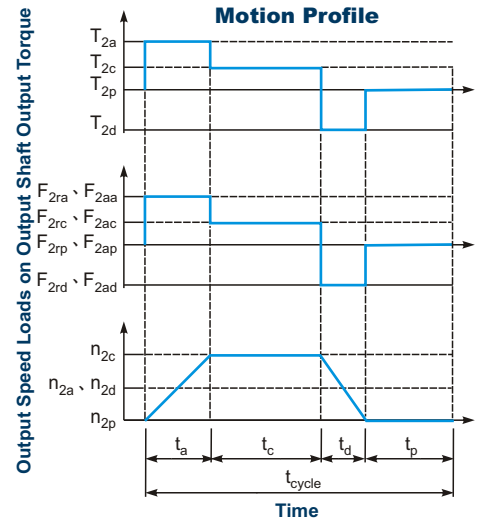

$$1. ED = \frac{t_a + t_c + t_d}{t_{cycle}} \times 100\%, t_{work} = t_a + t_c + t_d$$

Index : a. Acceleration, c. Constant,
 d. Deceleration, p. Pause **(Eq.1)**

$$2. i \cong \frac{n_m}{n_{work}}$$

n_m Output Speed of the Motor
 n_{work} Working Speed **(Eq.2)**

$$3. T_{2m} = 3 \sqrt{\frac{n_{2a} \times t_a \times T_{2a}^3 + n_{2c} \times t_c \times T_{2c}^3 + n_{2d} \times t_d \times T_{2d}^3}{n_{2a} \times t_a + n_{2c} \times t_c + n_{2d} \times t_d}}$$

(Eq.3)

$$4. T_{2max} = T_{mB} \times i \times K_s \times \eta$$

where K_s is

K_s	No. of Cycles / hr
1.0	0 ~ 1,000
1.1	1,000 ~ 1,500
1.3	1,500 ~ 2,000
1.6	2,000 ~ 3,000
1.8	3,000 ~ 5,000

T_{mB} Max. Output Torque of the Motor

$$\eta \text{ Efficiency of the Gearbox} \quad \text{(Eq.4)}$$

$$5. n_{2a} = n_{2d} = \frac{1}{2} \times n_{2c}$$

$$n_{2m} = \frac{n_{2a} \times t_a + n_{2c} \times t_c + n_{2d} \times t_d}{t_a + t_c + t_d}$$

$$n_{2N} = \frac{n_{1N}}{i} \quad \text{(Eq.5)}$$

$$6. F_{2rm} = 3 \sqrt{\frac{n_{2a} \times t_a \times F_{2ra}^3 + n_{2c} \times t_c \times F_{2rc}^3 + n_{2d} \times t_d \times F_{2rd}^3}{n_{2a} \times t_a + n_{2c} \times t_c + n_{2d} \times t_d}}$$

$$F_{2am} = 3 \sqrt{\frac{n_{2a} \times t_a \times F_{2aa}^3 + n_{2c} \times t_c \times F_{2ac}^3 + n_{2d} \times t_d \times F_{2ad}^3}{n_{2a} \times t_a + n_{2c} \times t_c + n_{2d} \times t_d}}$$

(Eq.6)

Glossary

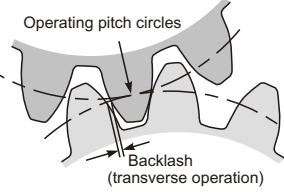
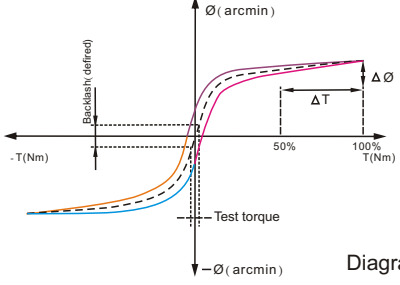
Emergency Stop Torque T_{2NOT}	Nm	The Emergency Stop Torque is the maximum permitted torque at the output of gearbox. This may happen only occasionally and may not exceed 1000 times during the whole service life.
Max. Acceleration Torque T_{2B}	Nm	Under the Cyclic Operation (S5), the Max. Acceleration Torque is the maximum torque which can be transmitted only briefly to the output of gearbox up to 1000 cycles/hr.
No Load Running Torque	Nm	The No Load Running Torque is the min. torque to overcome the internal friction of a gearbox without loading*.
Nominal Input Speed n_{1N}	rpm	The Nominal Input Speed is the permitted input speed of gearbox by the Continuous Operation (S1) while the housing temperature does not exceed 90°C. This value is measured at environment temperature 25°C.
Max. Input Speed n_{1B}	rpm	The Max. Input Speed is the max. permitted input speed of gearbox by the Cyclic operation (S5). This value is measured at environment temperature 25°C and serves as the absolute limit of the gearbox.
Backlash	arcmin	<p>The Backlash is the maximum angular measurement between two teeth of gears when the transverse operation occurs (refer to Diagram 1). The arcmin is the measurement unit for the backlash. One arcmin equals 1/ 60 degree, symbolized as 1'.</p>  <p style="text-align: right;">Diagram 1</p>
Torsional Rigidity	Nm/arcmin	<p>Torsional Rigidity is the quotient ($\Delta T / \Delta \emptyset$) between the applied torque and resulting torsion angle. This value indicates how many torque needed on gearbox to rotate the output shaft for 1 arcmin. The Torsional Rigidity can be determined by Hysteresis Curve.</p> <p>Hysteresis Curve When the input shaft is locked, increase torque at the output slowly up to T_{2B} in both directions and then release the torque gradually. According to the measured torque and torsion angle, a closed curve will be acquired as Diagram 2.</p>  <p style="text-align: right;">Diagram 2</p>
Efficiency η	%	The transmission efficiency of the gears inside a gearbox (without friction).
Operating Temperature	° C	The Operating Temperature indicates the temperature of gearbox housing.
Lubrication		APEX uses synthetic lubrication grease. There are other grease available, please contact APEX.
Running Noise	dB(A)	The Running Noise is measured depends on gearbox size, the ratio and the speed*. Higher speed induces usually higher noise level, while higher ratio induces lower noise level.
Moment of Inertia J_1	kg. cm ²	The Moment of Inertia J1 is a measurement of the effort applied to an object to maintain its momentary condition at rest or rotating.
Breakaway Torque	Nm	The Breakaway Torque is the minimum torque to start the rotation from the input side of gearbox. A smaller size or a higher ratio gearbox requests less Breakaway Torque.
Back Driving Torque	Nm	The Back Driving Torque is the minimum torque to start the rotation from the output side of gearbox. A larger size or a higher ratio gearbox requests greater Back Driving Torque.

* This value is measured at environment temperature 25°C and the input speed 3000 rpm. If the Nominal Input Speed n_{1N} of gearbox is over 3000 rpm, this value is measured by that specific Nominal Input Speed.

© 2013 by APEX DYNAMICS, INC.

In terms of the continuously development of products, the modifications and copy rights of all technical specifications, illustrations and drawings in this catalog are reserved by APEX DYNAMICS, INC. For the newest data and information, please visit APEX website: www.apexdynamics.com.



APEX DYNAMICS, INC.

No. 10, Keyuan 3rd Road, Situn District, Taichung City 407, Taiwan R.O.C

TEL: 886-4-24650219 / FAX: 886-4-24650118

E-Mail: sales@apexdyna.com Website: www.apexdyna.com

APEX-2013-04-PII SERIES-1.0E-2.0V

