

LoPro®

Actuated Linear Guidance System

Built on

DUAL VEE

Motion Technology®

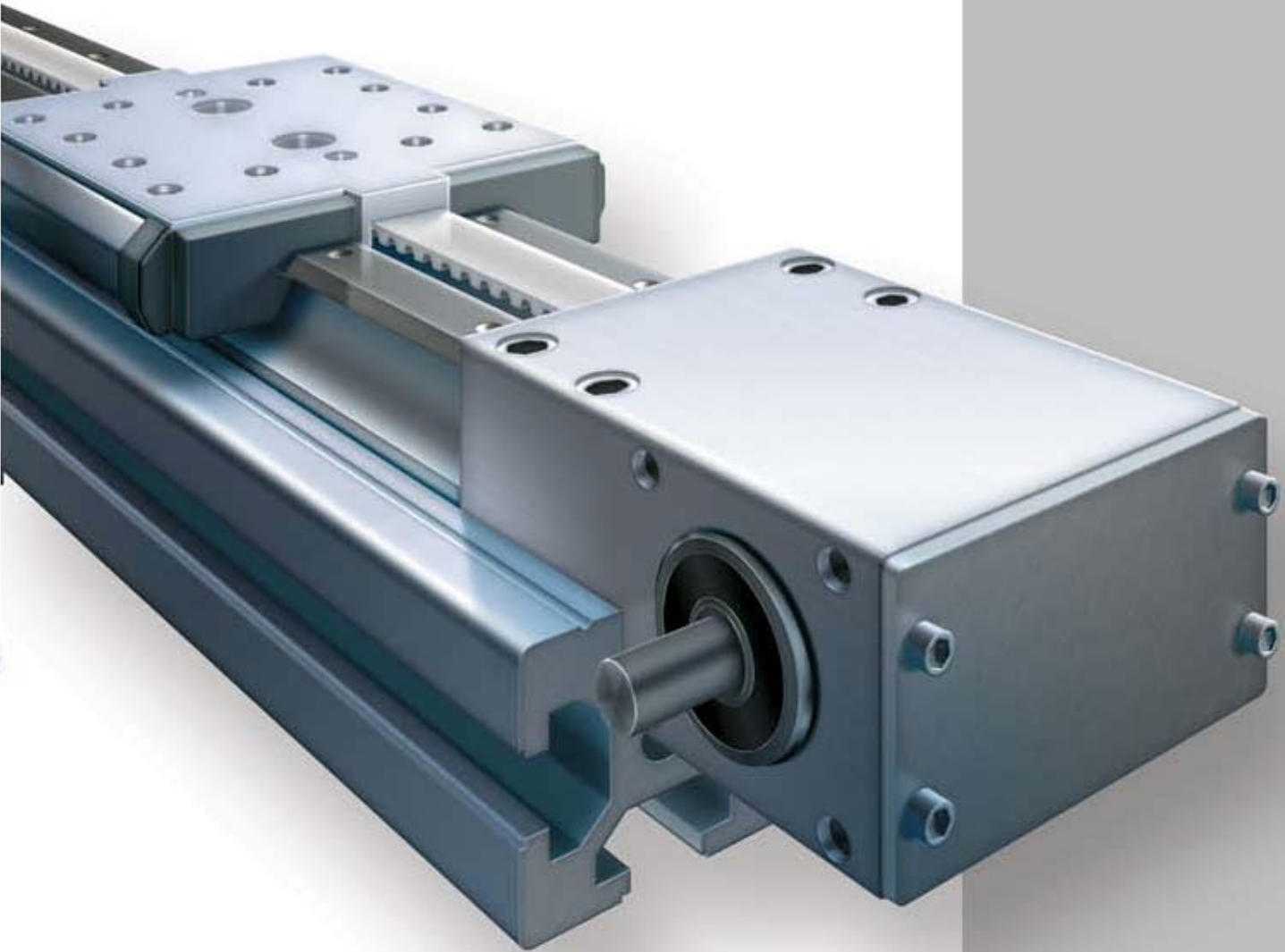

DUALVEE Motion Technology®

Bishop-Wisecarver, manufacturer of the ORIGINAL DualVee® guide wheel, is recognized as the market leader for guide wheel technology. In 1967, Bud Wisecarver patented DualVee Motion Technology® (DMT). Three main components define DMT – the DualVee guide wheel, its mating vee profile track with patented mounting shoulder, and support bushings. DMT is one of the most popular guided motion technologies due to its self-cleaning action and self-aligning track, which result in an overall lower installation cost.

Features and Benefits

DualVee Motion Technology is ideal for a wide array of applications, from the clean room to the sawmill. DualVee's recirculating elements are self-contained and isolated from the environment. Without direct contact with the rail that can subject bearings to contamination, and ultimately, premature failure, DMT excels in dirty and severe environments.

DMT's circular bearing design also allows for faster acceleration and speeds.

- Carbon or stainless steel components
- Speeds up to 5.5 m/s
- Acceleration up to 5 g's
- High accuracy and repeatability
- High temperature and clean room options
- Corrosion resistant versions available
- Ground mounting surfaces not required
- Low noise
- Smooth action
- Long lengths

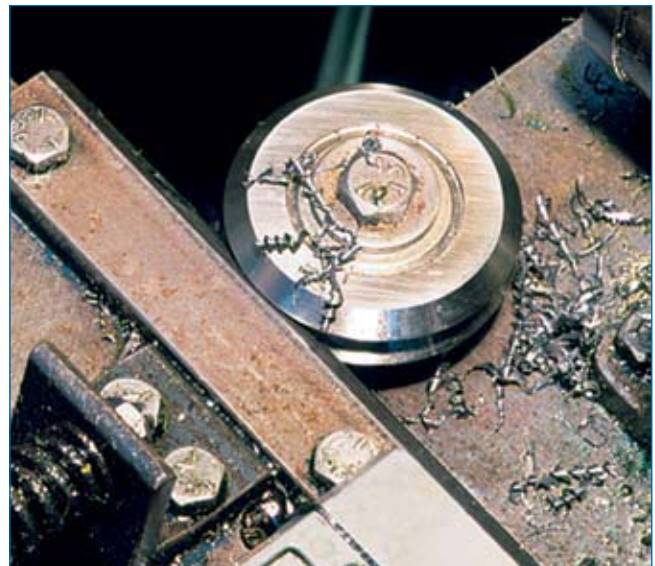
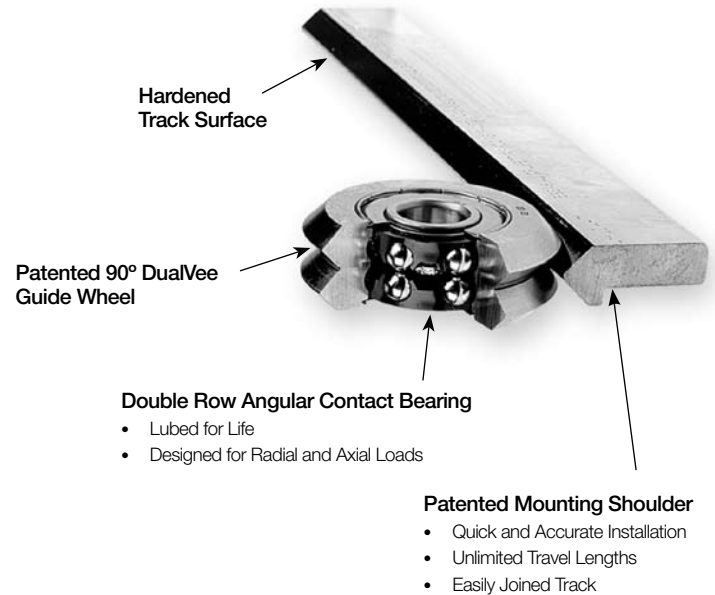

Designed for Dirty and Severe Environments

The patented 90° DualVee design creates a velocity gradient, since the circumference of the wheel is greater at the major diameter, resulting in a constant sweeping action that cleans debris from the track.

Product Overview

LoPro® Linear Motion Systems

LoPro linear motion systems are available in four sizes and in belt, lead screw, ball screw and chain driven configurations, as well as un-driven. LoPro provides a tough, cost effective, low friction, low profile modular solution, built to withstand a wide range of operating environments. LoPro is the system of choice for wood, packaging and textile machinery, as well as the clean room or laboratory.

LoPro has the lowest profile in the industry, accomplished by mounting two lengths of our hardened steel track to a low profile milled aluminum track plate. The veeways are pre-aligned and parallel to within .002in (0.05mm). Track plate is available in single piece lengths up to 10 feet (3m), but are routinely butt-joined with a staggered track arrangement for long custom lengths.

Complete Integrated Package

- Belt, chain, ball screw, lead screw, or un-driven
- 4 wheel plate sizes to accommodate axial loads from 222 lbs to 3,526 lbs (988N to 15,684N)
- Corrosion resistant versions available



Belt Drive
AT style steel reinforced polyurethane belting



Lead Screw
Lead accuracies to .0006 in/in (mm/mm)



Ball Screw
Accurate to .004 in/ft (100 µm/300mm)

Chain Drive
Standard or corrosion resistant ANSI roller chain

Table of Contents

Product Overview	1-3
Application Examples	4
Belt Driven Systems	5-14
Drive Ends	9
Idler Ends	10
Wheel Plate Options	11-12
Support Beams	13
System Ordering Information	14
Chain Driven Systems.....	15-24
Drive Ends	19
Idler Ends.....	20
Wheel Plate Options.....	21-22
Support Beams.....	23
System Ordering Information.....	24
Lead Screw Driven Systems	25-33
Fixed End & Simple End	29
Wheel Plate Options.....	30-31
Support Beams.....	32
System Ordering Information.....	33
Ball Screw Driven Systems.....	34-42
Fixed End & Simple End.....	38
Wheel Plate Options.....	39-40
Support Beams.....	41
System Ordering Information.....	42
Un-driven Systems	43-49
Wheel Plate Options.....	46-47
Support Beams.....	48
System Ordering Information.....	49
Track Plate Assemblies.....	50
Tools and Accessories.....	51-53
Motor Mounts	51
Gantry Brackets	52
Other Tools and Accessories.....	53
Technical Reference.....	54-55
System Mass Calculations	55
Custom Engineered Systems.....	56

Intentionally Omitted

Intentionally Omitted

Application and Design Assistance

888.580.8272 925.439.8272

3D Modeling and CAD Drawings

www.bwc.com

Product Overview

Proven Technology

DMT has been successfully employed in industrial linear motion systems for 40 years.

High Speed

Speeds up to 5.5 m/s, and acceleration up to 5 g's.

Low Profile

Sleek, compact design.

Low Noise/Low Vibration

Reduces noise and vibration substantially over recirculating ball designs.

Long Stroke Lengths

Tracks can be butt-joined to create systems of virtually any length (screw driven system lengths are limited by available screw lengths).

Tolerant of Contamination and Debris

Inherent surface velocity gradient provides a constant sweeping action.

Flexibility and Simplicity

Modular system permits optimized engineered solutions for specific application requirements. Wheel-to-track fit-up makes assembly and field maintenance easy to perform.

System Components

Linear Guide

The linear guide consists of a track plate assembly(ies) and wheel plate assembly(ies), each wheel plate assembly containing four DualVee wheels.



Wiper wheel plate assembly shown consisting of four DualVee wheels, bushings and a carriage plate



Track plate assembly consisting of two or more lengths of induction hardened steel track mounted to an anodized aluminum substrate

Linear Actuator

Belt, chain, lead screw, or ball screw driven.

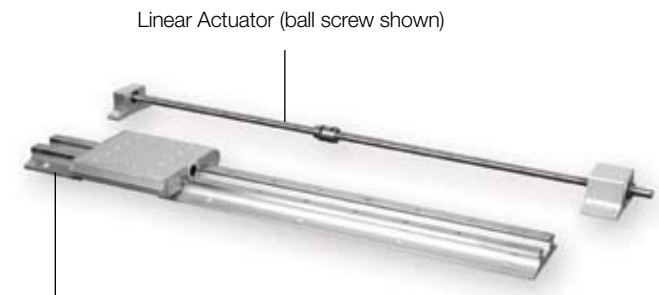

Linear Guide with wheel plate

Drive Ends



Motor Mounts (Optional)



Support Beams

- Aluminum (standard)
- Steel (standard)
- Stainless Steel (custom)

Typical Configurations

Single Axis Linear Motion

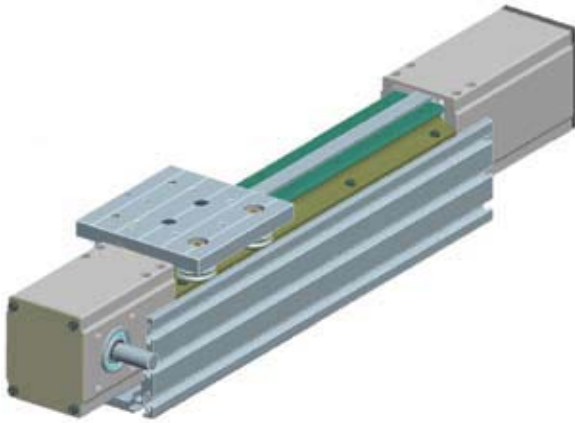

X-Y Gantry Arrangement

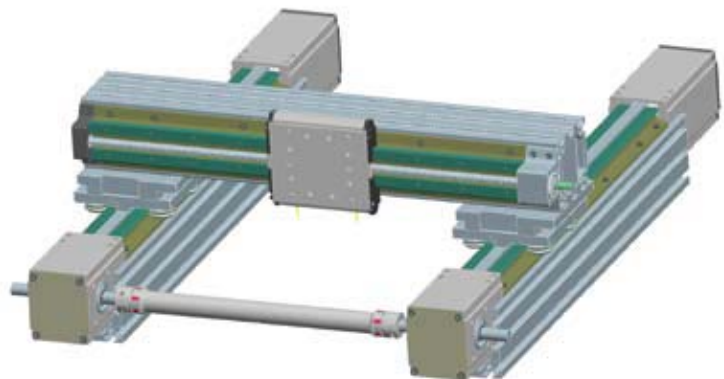

X-Y-Z Multi-Axis Arrangement

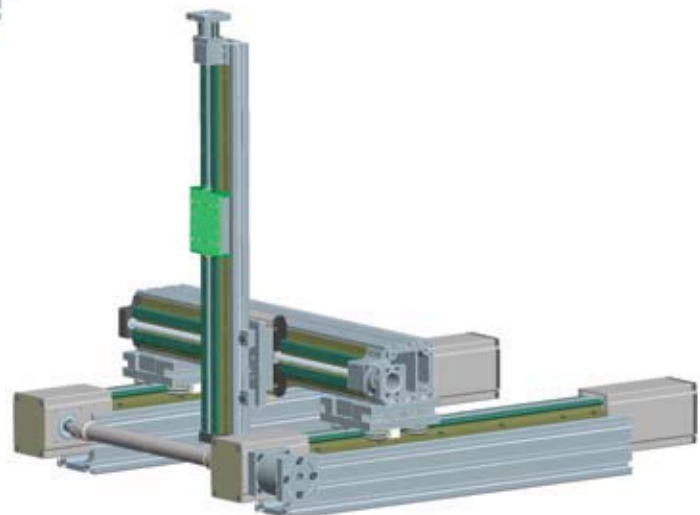
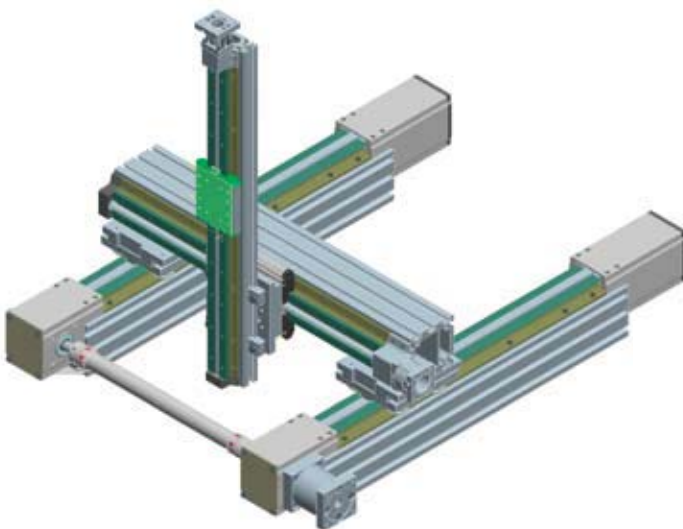

Multi-Industry Applications

DualVee-based linear guides are popular worldwide and used throughout a broad range of industries.

- Machine tool
- Laboratory
- Automotive production
- Industrial automation
- Biomedical
- Inspection equipment
- Material handling equipment
- Textile machinery
- Paper processing and converting
- Semiconductor
- Packaging machinery
- Electronics assembly
- Non-contact machining equipment



Bishop-Wisecarver specializes in long length challenges. Belt and chain driven LoPro linear actuators have been fabricated up to 80 feet.



Automotive assembly plant. LoPro is used to carry an air gun and parts for assembly, minimizing the possibility of workers tripping over long hoses and carrying heavy loads.

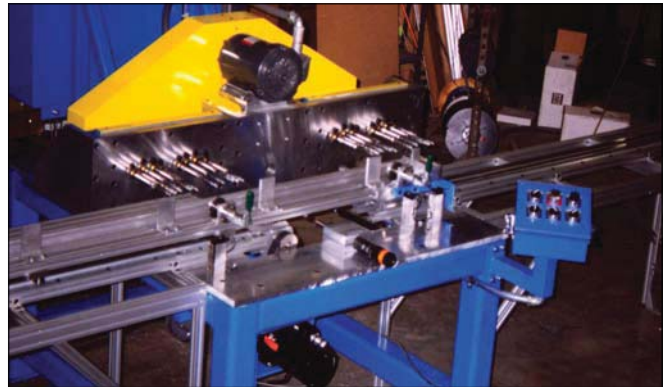

Door frame drilling jig. With LoPro's precise travel and fast acceleration, exact placement of holes for production door frames is easy and repeatable every time.



This "X-Y" Plasma cutter, using a LoPro ball screw driven system, operates in a harsh environment consisting of smoke, abrasive dust, weld splatter, hot sparks and elevated temperatures.



A chain driven LoPro is used on a vinyl fence production machine pushing vinyl fence components into a drill press.

Chain Driven Systems

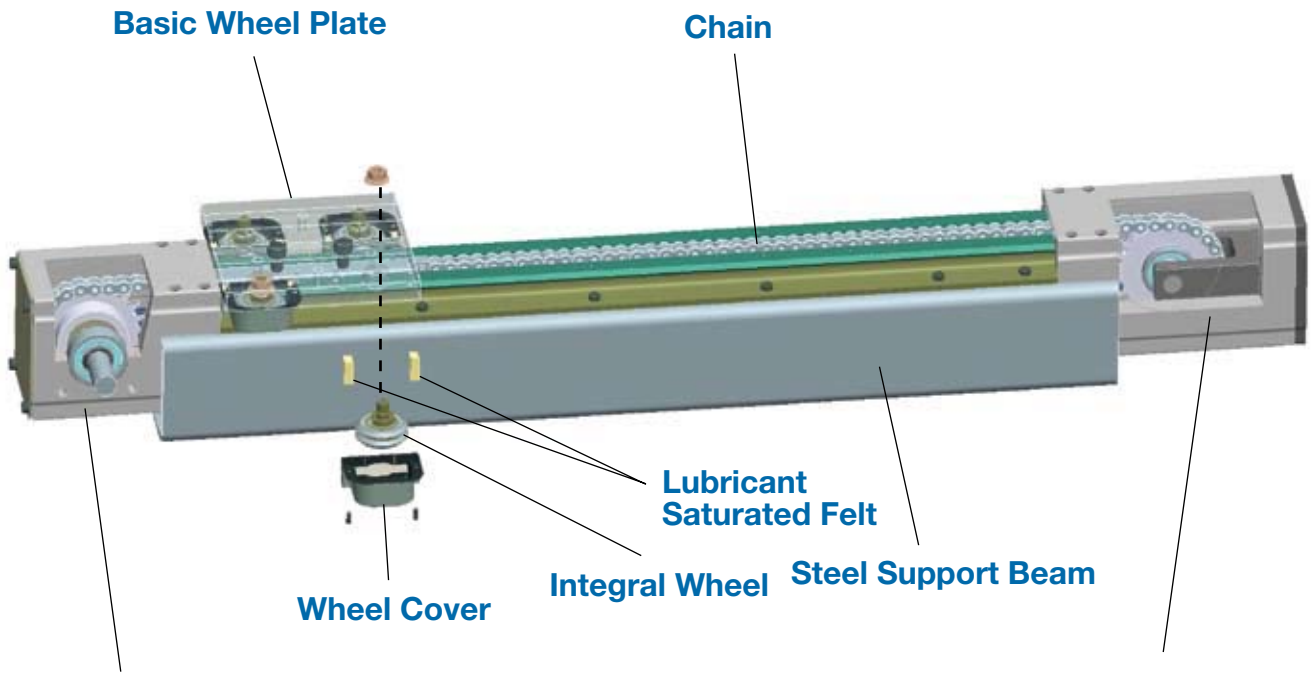

Drive End

Constructed with anodized aluminum housing and hardened stainless steel input drive shaft. Sprocket and shaft are supported by two single row ball bearings.

Idler End with Tensioning Adjustment

Rugged anodized aluminum housing; sprocket is supported by two single row ball bearings. Chain tension adjustment screw is easily accessed on the back plate of the idler end assembly.

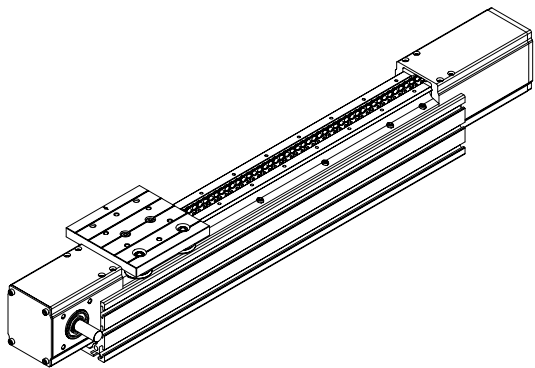

- Basic Wheel Plate
- Aluminum Support Beam

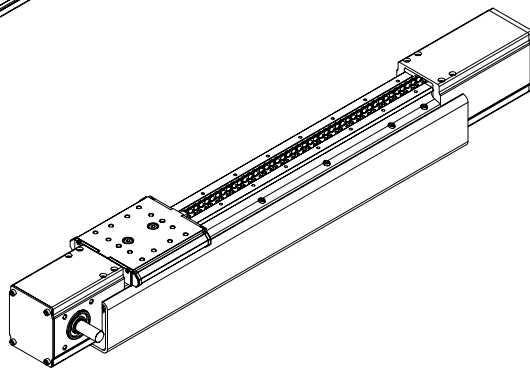

- Wiper Wheel Plate
- Steel Support Beam

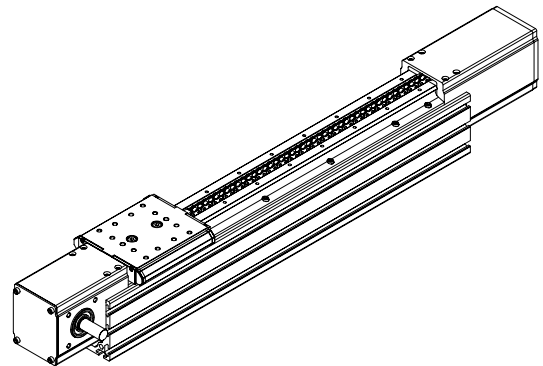

- Wiper Wheel Plate
- Aluminum Support Beam

Chain

Chain Driven Systems

- Complete chain actuated system, ready for installation
- Ideal for vertical hoisting and large load actuation over long lengths
- Standard or corrosion resistant ANSI roller chain
- Accurate to .015 in/ft (0.4mm/300mm)
- Repeatable within .008 in (0.2mm)
- Small and large drive options available on size 2
- Aluminum support beams, steel beams or un-mounted (without beams)
- Basic wheel plate or wiper wheel plate
- Optional NEMA and IEC motor mounts
- Steel or stainless steel drive end sprockets

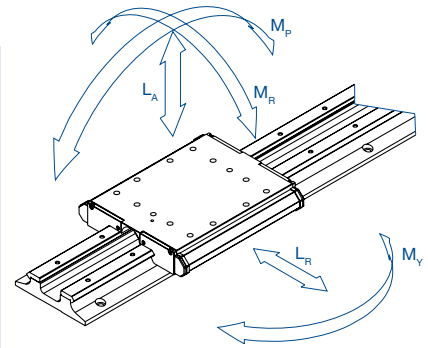

Carriage Assembly Load Capacities										
System Size	Axial Load Capacity L_A		Radial Load Capacity L_R		Pitch Moment Capacity M_P		Yaw Moment Capacity M_Y		Roll Moment Capacity M_R	
	N	lbs	N	lbs	N-m	ft-lbf	N-m	ft-lbf	N-m	ft-lbf
1	988	222	2391	538	26	18.9	62	45.7	27	19.8
2S/2L	2450	551	5194	1168	95	70.3	202	148.9	100	73.8
3	6668	1499	11564	2600	346	254.9	599	442.1	372	274.1
4	15684	3526	19012	4274	1220	899.5	1478	1090.3	1174	865.6

LoPro System Chain Load Capacities										Drive End Sprockets	
System Size	Chain Size Single Strand	Static/Slow Speed Working Load				Working Load at 0.5 m/s				Pitch Diameter	No. of Teeth
		Steel		Stainless Steel		Steel		Stainless Steel			
		N	lbs	N	lbs	N	lbs	N	lbs		
1	25	431	97	347	78	267	60	214	48	24.5mm (.966in)	12
2S	35	1036	233	841	189	618	139	494	111	36.8mm (1.449in)	12
2L	35	1036	233	841	189	645	145	516	116	79.0mm (3.111in)	26
3	40	1975	444	1481	333	1152	259	863	194	93.3mm (3.672in)	23
4	50	3261	733	2322	522	1788	402	1272	286	91.4mm (3.599in)	18

Working load varies with speed. Contact Bishop-Wisecarver for specific application information.

Chain Driven Systems - Wiper Wheel Plate

Beam Mounted

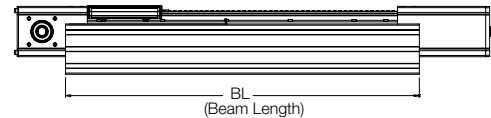
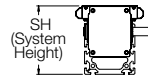
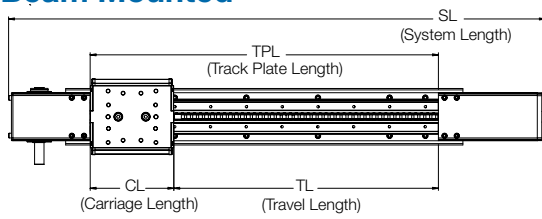

Aluminum Beam

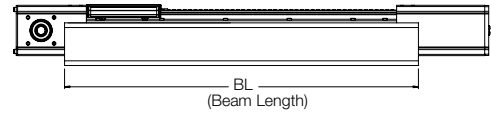
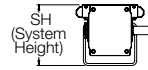

Steel Beam

Un-mounted*

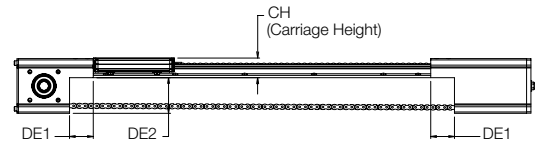
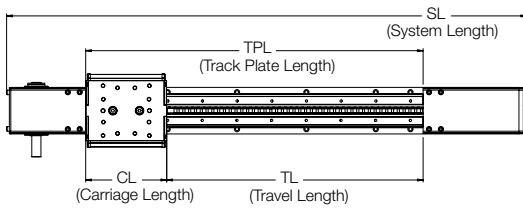

Size	Track Plate Length TPL (=TL+CL)	System Length SL	System Height SH			Beam Length BL	Carriage Height CH
			Aluminum	Steel	Un-mounted	Beam Mounted	Un-mounted
1	TL+94.0mm TL+3.701in	TPL+173.6mm TPL+6.833in	63.0mm 2.482in	61.1mm 2.407in	39.0mm 1.537in	TL+154.0mm TL+6.063in	23.0mm .907in
2S	TL+129.9mm TL+5.114in	TPL+227.6mm TPL+8.960in	73.0mm 2.874in	71.1mm 2.799in	61.0mm 2.401in	TL+209.9mm TL+8.264in	33.0mm 1.299in
2L	TL+129.9mm TL+5.114in	TPL+318.1mm TPL+12.522in	113.0mm 4.449in	109.2mm 4.299in	101.0mm 3.976in	TL+209.9mm TL+8.264in	33.0mm 1.299in
3	TL+177.6mm TL+6.990in	TPL+400.1mm TPL+15.751in	163.0mm 6.417in	144.6mm 5.693in	121.1mm 4.768in	TL+281.6mm TL+11.084in	43.0mm 1.693in
4	TL+243.8mm TL+9.600in	TPL+440.9mm TPL+17.358in	N/A	156.6mm 6.167in	130.0mm 5.120in	TL+351.8mm TL+13.852in	55.0mm 2.167in

Size	Drive End Cutout Width DE1	Drive End Cutout Height DE2	System Inertia J (A + B + C)		
	Un-mounted	Un-mounted	A	B ¹	C ²
1	30.0mm 1.181in	16.0mm .630in	71.7kg•mm ² .245lb•in ²	.0508kg•mm x TL .00441lb•in x TL	188mm ² x M .292in ² x M
2S	40.0mm 1.575in	28.0mm 1.102in	500kg•mm ² 1.71lb•in ²	.280kg•mm x TL .0243lb•in x TL	423mm ² x M .656in ² x M
2L	40.0mm 1.575in	68.0mm 2.677in	3140kg•mm ² 10.7lb•in ²	1.29kg•mm x TL .112lb•in x TL	1950mm ² x M 3.02in ² x M
3	52.0mm 2.047in	78.1mm 3.075in	10100kg•mm ² 34.4lb•in ²	3.40kg•mm x TL .295lb•in x TL	2720mm ² x M 4.21in ² x M
4	54.0mm 2.126in	75.0mm 2.953in	19300kg•mm ² 66.1lb•in ²	5.34kg•mm x TL .463lb•in x TL	2610mm ² x M 4.05in ² x M

*Un-mounted systems are designed for mounting to a customer-supplied mounting surface. System straightness and flatness are determined by mounting surface accuracy. Continuous support along the entire track plate length and under drive end mounting surfaces is required.

1. TL (Travel Length) must be in mm for metric calculation, inches for English calculation.
2. M (Mass of payload on the carriage) must be in kg for metric calculation, lbm for English calculation.

Chain Driven Systems - Basic Wheel Plate

Beam Mounted

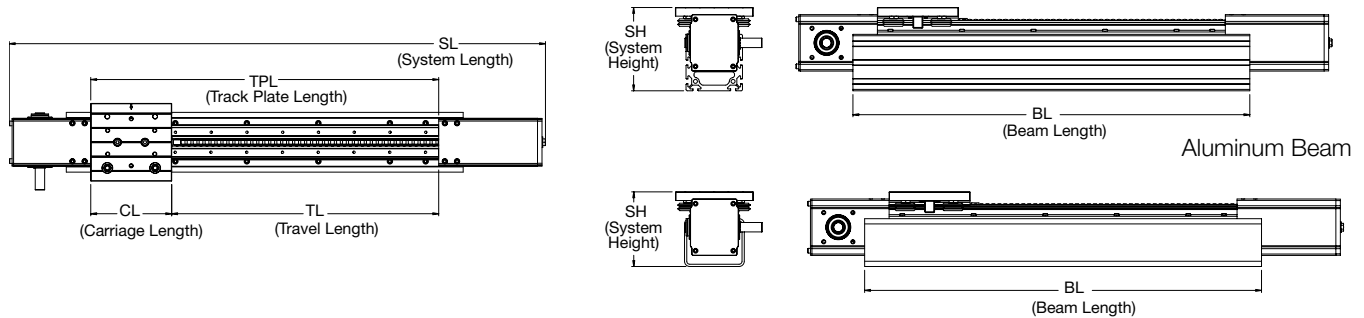

Un-mounted*

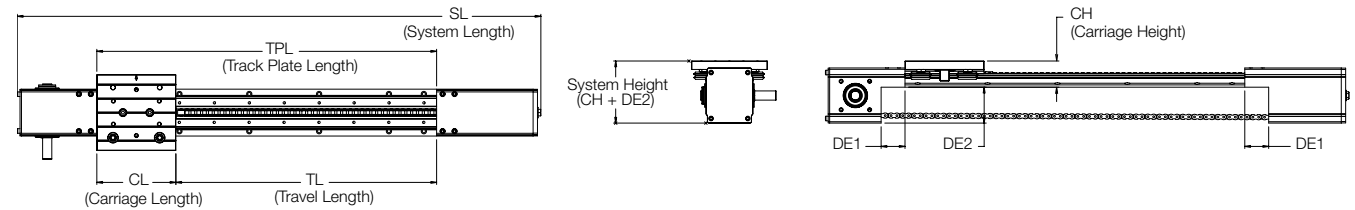

Size	Track Plate Length TPL (=TL+CL)	System Length SL	System Height SH			Beam Length BL	Carriage Height CH
			Aluminum	Steel	Un-mounted	Beam Mounted	Un-mounted
1	TL+90.0mm TL+3.543in	TPL+173.6mm TPL+6.833in	72.1mm 2.840in	70.2mm 2.765in	48.1mm 1.895in	TL+150.0mm TL+5.906in	32.1mm 1.265in
2S	TL+127.0mm TL+5.000in	TPL+227.6mm TPL+8.960in	83.0mm 3.269in	81.1mm 3.194in	71.0mm 2.796in	TL+206.8mm TL+8.140in	43.0mm 1.694in
2L	TL+127.0mm TL+5.000in	TPL+318.1mm TPL+12.522in	123.0mm 4.844in	119.2mm 4.694in	111.0mm 4.371in	TL+206.8mm TL+8.140in	43.0mm 1.694in
3	TL+172.0mm TL+6.772in	TPL+400.1mm TPL+15.751in	177.0mm 6.969in	158.6mm 6.245in	135.1mm 5.320in	TL+276.0mm TL+10.866in	57.0mm 2.244in
4	TL+242.0mm TL+9.528in	TPL+440.9mm TPL+17.358in	N/A	170.6mm 6.718in	144.0mm 5.671in	TL+350.0mm TL+13.780in	69.0mm 2.718in

Size	Drive End Cutout Width DE1	Drive End Cutout Height DE2	System Inertia J (A + B + C)		
	Un-mounted	Un-mounted	A	B ¹	C ²
1	30.0mm 1.181in	16.0mm .630in	93.2kg•mm ² .318lb•in ²	.0508kg•mm x TL .00441lb•in x TL	188mm ² x M .292in ² x M
2S	40.0mm 1.575in	28.0mm 1.102in	591kg•mm ² 2.02lb•in ²	.280kg•mm x TL .0243lb•in x TL	423mm ² x M .656in ² x M
2L	40.0mm 1.575in	68.0mm 2.677in	3560kg•mm ² 12.2lb•in ²	1.29kg•mm x TL .112lb•in x TL	1950mm ² x M 3.02in ² x M
3	52.0mm 2.047in	78.1mm 3.075in	11500kg•mm ² 39.4lb•in ²	3.40kg•mm x TL .295lb•in x TL	2720mm ² x M 4.21in ² x M
4	54.0mm 2.126in	75.0mm 2.953in	21900kg•mm ² 74.9lb•in ²	5.34kg•mm x TL .463lb•in x TL	2610mm ² x M 4.05in ² x M

*Un-mounted systems are designed for mounting to a customer-supplied mounting surface. System straightness and flatness are determined by mounting surface accuracy. Continuous support along the entire track plate length and under drive end mounting surfaces is required.

1. TL (Travel Length) must be in mm for metric calculation, inches for English calculation.
2. M (Mass of payload on the carriage) must be in kg for metric calculation, lbm for English calculation.

Drive Ends for Chain Driven Systems

- Designed for high performance, high cycling linear motion
- Incorporates high quality radial bearings with a high strength aircraft grade aluminum housing
- Drive ends are available with optional relief holes for extremely aggressive environments with high particulate matter. Contact Bishop-Wisecarver for details.

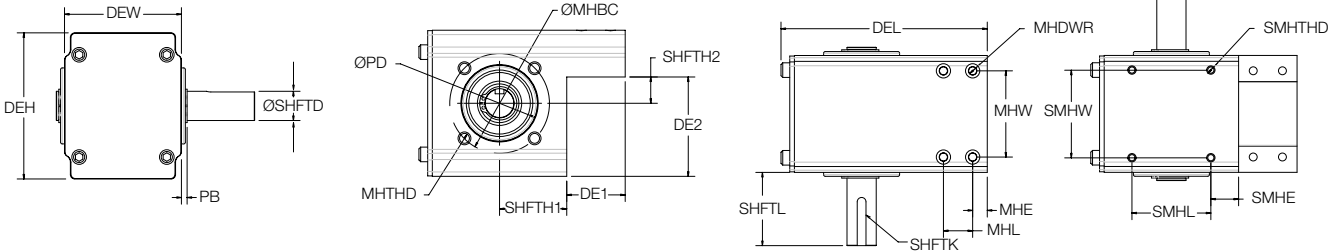
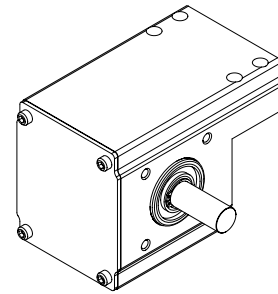

Size	Drive End Length	Drive End Width	Drive End Height	Shaft Length	Shaft Diameter	Shaft Square Key Size	Shaft Locations		Drive End Cutout Width	Drive End Cutout Height	Mounting Hardware
	DEL	DEW	DEH	SHFTL	SHFTD	SHFTK	SHFTH1	SHFTH2	DE1	DE2	MHDWR
1	76.2mm 2.999in	50.0mm 1.969in	38.0mm 1.496in	29.6mm 1.166in	9.0mm .354in	3mm	20.0mm .787in	-3.0mm .118in	30.0mm 1.181in	16.0mm .630in	M3x22mm MIN
2S	95.2mm 3.748in	72.0mm 2.835in	60.0mm 2.362in	36.7mm 1.445in	12.0mm .472in	4mm	24.0mm .945in	-2.0mm .079in	40.0mm 1.575in	28.0mm 1.102in	M5x30mm MIN
2L	141.2mm 5.558in	80.0mm 3.150in	100.0mm 3.937in	50.1mm 1.973in	20.0mm .787in	6mm	46.0mm 1.811in	18.0mm .709in	40.0mm 1.575in	68.0mm 2.677in	M5x35mm MIN
3	173.2mm 6.818in	102.0mm 4.016in	120.0mm 4.724in	50.1mm 1.973in	20.0mm .787in	6mm	56.0mm 2.205in	18.1mm .713in	52.0mm 2.047in	78.1mm 3.075in	M6x45mm MIN
4	183.2mm 7.212in	140.0mm 5.512in	128.0mm 5.039in	50.1mm 1.973in	20.0mm .787in	6mm	59.0mm 2.323in	11.0mm .434in	54.0mm 2.126in	75.0mm 2.953in	M8x55mm MIN

Size	Mounting Holes (Typical)			Motor Mount				Ancillary Mounting Holes			
	Width	Edge Spacing	Length	Pilot Diameter	Pilot Bearing Height	Bolt Circle Diameter	Mounting Hole Thread	Width	Length	Edge Spacing	Thread
	MHW	MHE	MHL	PD	PB	MHBC	MHTHD	SMHW	SMHL	SMHE	SMHTHD
1	40.0mm 1.575in	6.0mm .236in	18.0mm .709in	24.0mm .945in	1.7mm .067in	42.4mm 1.670in	M4x0.7	42.0mm 1.654in	N/A	30.0mm 1.181in	M4x0.7
2S	59.0mm 2.323in	10.0mm .394in	20.0mm .787in	28.0mm 1.102in	1.7mm .067in	50.9mm 2.004in	M5x0.8	60.0mm 2.362in	N/A	30.0mm 1.181in	M5x0.8
2L	59.0mm 2.323in	10.0mm .394in	20.0mm .787in	52.0mm 2.047in	2.7mm .106in	67.9mm 2.673in	M8x1.25	60.0mm 2.362in	54.0mm 2.126in	19.0mm .748in	M5x0.8
3	81.0mm 3.189in	13.0mm .512in	26.0mm 1.024in	52.0mm 2.047in	2.7mm .106in	87.7mm 3.452in	M8x1.25	80.0mm 3.150in	58.0mm 2.283in	27.0mm 1.063in	M6x1.0
4	111.0mm 4.370in	13.5mm .532in	27.0mm 1.063in	52.0mm 2.047in	2.7mm .106in	90.5mm 3.564in	M8x1.25	110.0mm 4.331in	64.0mm 2.520in	27.0mm 1.063in	M8x1.25

Right hand version shown. Dual shaft, left hand, and corrosion resistant versions are also available. Contact Bishop-Wisecarver for details.

Idler Ends for Chain Driven Systems

- Chain adjustment is easily accomplished via rotation of a single, easy-to-access adjustment screw
- High quality radial bearings and high strength aluminum housing provides smooth, accurate linear motion
- Idler ends are available with optional relief holes for extremely aggressive environments with high particulate matter. Contact Bishop-Wisecarver for details.

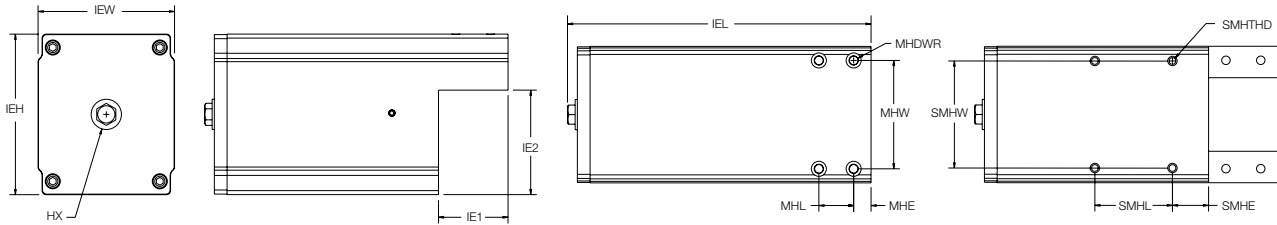
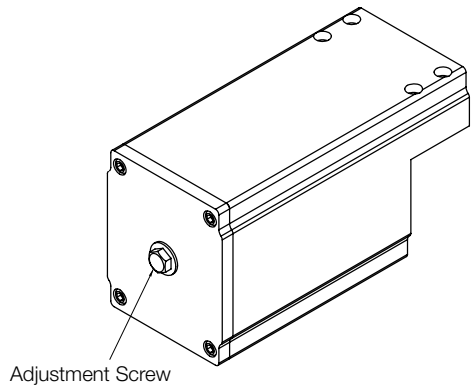

Size	Idler End Length	Bottom View		Idler End Cutout Width	Idler End Cutout Height	Mounting Hardware
		Idler End Width	Idler End Height			
		IEL	IEW			
1	97.4mm 3.834in	50.0mm 1.969in	38.0mm 1.496in	30.0mm 1.181in	16.0mm .630in	M3x22mm MIN
2S	132.4mm 5.212in	72.0mm 2.835in	60.0mm 2.362in	40.0mm 1.575in	28.0mm 1.102in	M5x30mm MIN
2L	176.9mm 6.964in	80.0mm 3.150in	100.0mm 3.937in	40.0mm 1.575in	68.0mm 2.677in	M5x35mm MIN
3	226.9mm 8.933in	102.0mm 4.016in	120.0mm 4.724in	52.0mm 2.047in	78.1mm 3.075in	M6x45mm MIN
4	257.7mm 10.146in	140.0mm 5.512in	128.0mm 5.039in	54.0mm 2.126in	75.0mm 2.953in	M8x55mm MIN

Size	Mounting Holes (Typical)			Hex Head Adj. Screw	Ancillary Mounting Holes			
	Width	Edge Spacing	Length		Width	Length	Edge Spacing	Thread
	MHW	MHE	MHL		SMHW	SMHL	SMHE	SMHTD
1	40.0mm 1.575in	6.0mm .236in	18.0mm .709in	1/4in	42.0mm 1.654in	N/A	30.0mm 1.181in	M4x0.7
2S	59.0mm 2.323in	10.0mm .394in	20.0mm .787in	1/4in	60.0mm 2.362in	N/A	30.0mm 1.181in	M5x0.8
2L	59.0mm 2.323in	10.0mm .394in	20.0mm .787in	5/16in	60.0mm 2.362in	54.0mm 2.126in	19.0mm .748in	M5x0.8
3	81.0mm 3.189in	13.0mm .512in	26.0mm 1.024in	5/16in	80.0mm 3.150in	58.0mm 2.283in	27.0mm 1.063in	M6x1.0
4	111.0mm 4.370in	13.5mm .532in	27.0mm 1.063in	3/8in	110.0mm 4.331in	64.0mm 2.520in	27.0mm 1.063in	M8x1.25

Corrosion resistant versions are also available. Contact Bishop-Wisecarver for details.

Wheel Plate Options for Chain Driven Systems

Wiper Wheel Plate

Size	Part Number	Overall Length	Overall Width	Assembly Height	Wheel Plate Height	Wheel Vee Height	Wheel Spacing Length	Wheel Spacing Width
		A	B	C	D	E	F	G
1	LP1WPADG	94.0mm 3.700in	78.0mm 3.070in	18.5mm .730in	16.5mm .650in	9.5mm .375in	50.8mm 2.00in	53.29mm 2.098in
2	LP2WPADG	129.9mm 5.114in	115.3mm 4.540in	26.4mm 1.041in	23.3mm .916in	14.0mm .551in	76.2mm 3.00in	80.01mm 3.150in
3	LP3WPADG	177.6mm 6.990in	161.3mm 6.350in	35.6mm 1.403in	30.3mm 1.193in	18.0mm .709in	101.6mm 4.00in	109.22mm 4.300in
4	LP4WPADG	243.8mm 9.600in	213.2mm 8.394in	45.7mm 1.798in	39.5mm 1.553in	24.0mm .945in	152.4mm 6.00in	146.66mm 5.774in

For secondary wheel plate assembly, consult factory.

Size	Mounting Hole Length 1	Mounting Hole Length 2	Mounting Hole Width 1	Mounting Hole Width 2	Mounting Hole Thread	Coupler Mounting Hole to Edge	Coupler Mounting Hole Length	Coupler Fastener	Weight in Grams
	H	I	J	K	L	M	N	O	
1	N/A	50.0mm 1.969in	50.0mm 1.969in	25.0mm .984in	M4x0.7	33.7mm 1.325in	26.7mm 1.05in	M5	194
2	30.0mm 1.181in	76.0mm 2.992in	76.0mm 2.992in	38.0mm 1.496in	M6x1.0	42.1mm 1.657in	45.7mm 1.80in	M8	628
3	38.0mm 1.496in	100.0mm 3.937in	100.0mm 3.937in	50.0mm 1.969in	M8x1.25	59.6mm 2.345in	58.4mm 2.30in	M10	1629
4	66.0mm 2.598in	152.0mm 5.984in	152.0mm 5.984in	66.0mm 2.598in	M10x1.5	71.1mm 2.800in	101.6mm 4.00in	M12	3816

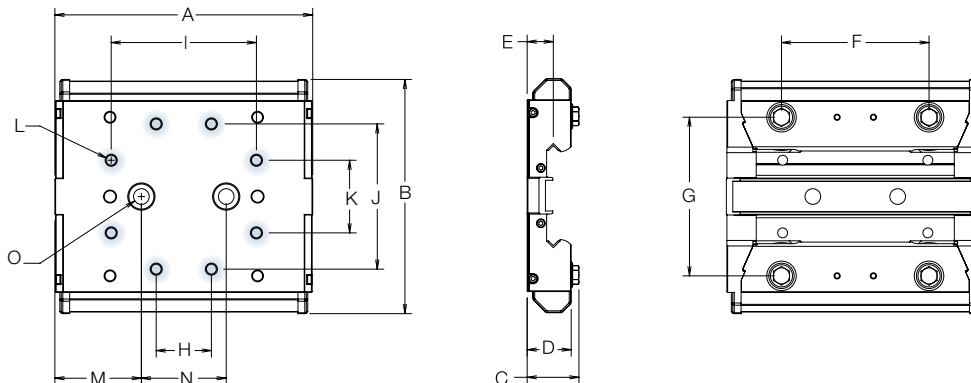

Highlighted holes indicate customer mounting holes

Wheel plate assemblies included with complete systems. See system ordering information, page 24.

Wheel Plate Options for Chain Driven Systems

Basic Wheel Plate

Size	Part Number		Overall Length	Overall Width	Assembly Height	Wheel Plate Height	Wheel Vee Height	Wheel Spacing Length	Wheel Spacing Width
	Track Lubricators	Wheel Covers	A	B	C	D	E	F	G
1	BWP1SWTLBC	BWP1SWWCBC	90.0mm 3.54in	80.0mm 3.15in	23.09mm .909in	11.33mm .446in	18.62mm .733in	50.8mm 2.00in	53.29mm 2.098in
2	BWP2SWTLBC	BWP2SWWCBC	127.0mm 5.00in	116.0mm 4.57in	25.59mm 1.165in	14.40mm .567in	24.03mm .946in	76.2mm 3.00in	80.01mm 3.150in
3	BWP3SWTLBC	BWP3SWWCBC	172.0mm 6.77in	165.0mm 6.50in	39.93mm 1.572in	18.36mm .723in	32.00mm 1.260in	101.6mm 4.00in	109.22mm 4.300in
4	BWP4SWTLBC	BWP4SWWCBC	242.0mm 9.53in	222.0mm 8.74in	47.52mm 1.871in	21.64mm .852in	38.00mm 1.496in	152.4mm 6.00in	146.66mm 5.774in

Size	Mounting Hole Length	Mounting Hole Width 1	Mounting Hole Width 2	Mounting Hole Thread	Coupler Mounting Hole to Edge	Coupler Mounting Hole Length	Coupler Fastener	Weight in Grams ¹
	H	I	J	K	L	M	N	
1	50.0mm 1.969in	50.0mm 1.969in	25.0mm .984in	M4x0.7	31.67mm 1.247in	26.7mm 1.05in	M5	307
2	76.0mm 2.992in	76.0mm 2.992in	38.0mm 1.496in	M6x1.0	40.64mm 1.600in	45.7mm 1.80in	M8	835
3	100.0mm 3.937in	100.0mm 3.937in	50.0mm 1.969in	M8x1.25	56.79mm 2.236in	58.4mm 2.30in	M10	2153
4	152.0mm 5.984in	152.0mm 5.984in	66.0mm 2.598in	M10x1.5	70.21mm 2.764in	101.6mm 4.00in	M12	4765

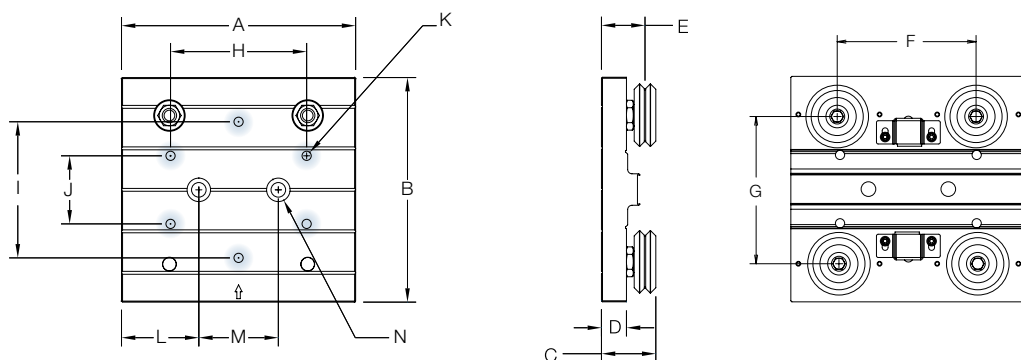

Highlighted holes indicate customer mounting holes. Wheel plate assembly shown with track lubricators.

Wheel plate assemblies included with complete systems. See system ordering information, page 24.

1. Weights shown are for wheel plates with wheel covers and without coupling kits. Basic wheel plates with track lubricators weigh slightly less.

Support Beams for Chain Driven Systems

Aluminum Support Beams

- Designed with industry standard cross section and T-slot (10mm) geometry
- Compatible with HepcoMotion®'s MCS aluminum frame and machine construction system from Bishop-Wisecarver, as well as other industry profile extrusions

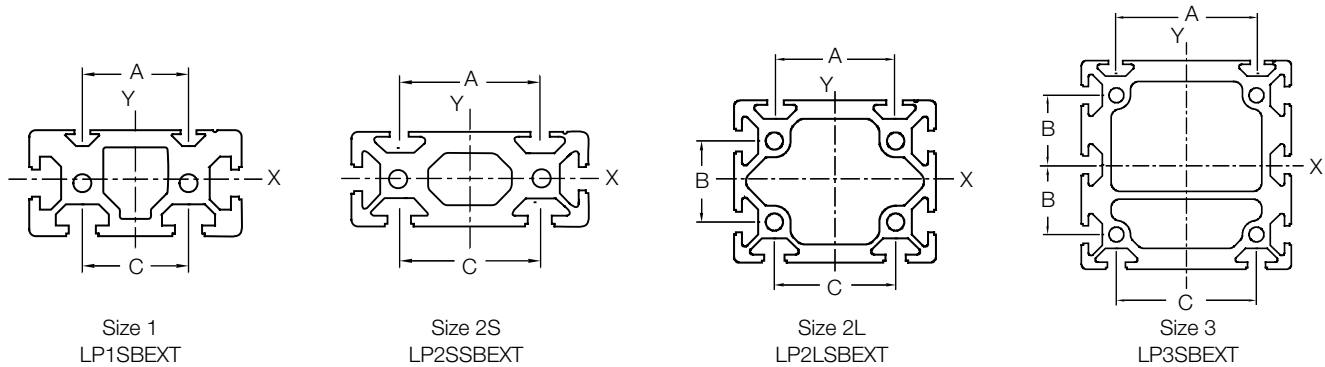

Size	Width	Height	Cross Sectional Area	Moment of Inertia X-Axis	Moment of Inertia Y-Axis	LoPro T-Slot A	LoPro T-Slot B	LoPro T-Slot C	Max Length
1	80.0mm 3.150in	40.0mm 1.575in	1679.9mm ² 2.60in ²	2.772x10 ⁵ mm ⁴ .66in ⁴	1.007x10 ⁶ mm ⁴ 2.42in ⁴	40.0mm 1.575in	N/A	40.0mm 1.575in	5.6m 18.37ft
2S	100.0mm 3.937in	40.0mm 1.575in	2130.1mm ² 3.30in ²	3.512x10 ⁵ mm ⁴ .84in ⁴	1.773x10 ⁶ mm ⁴ 4.26in ⁴	59.0mm 2.322in	N/A	60.0mm 2.362in	5.6m 18.37ft
2L	100.0mm 3.937in	80.0mm 3.150in	2698.3mm ² 4.18in ²	2.142x10 ⁶ mm ⁴ 5.15in ⁴	2.974x10 ⁶ mm ⁴ 7.14in ⁴	59.0mm 2.322in	40.0mm 1.575in	60.0mm 2.362in	5.6m 18.37ft
3	120.0mm 4.724in	120.0mm 4.724in	5146.6mm ² 7.98in ²	8.537x10 ⁶ mm ⁴ 20.51in ⁴	8.490x10 ⁶ mm ⁴ 20.40in ⁴	81.0mm 3.189in	40.0mm 1.575in	80.0mm 3.150in	5.6m 18.37ft

Steel Support Beams

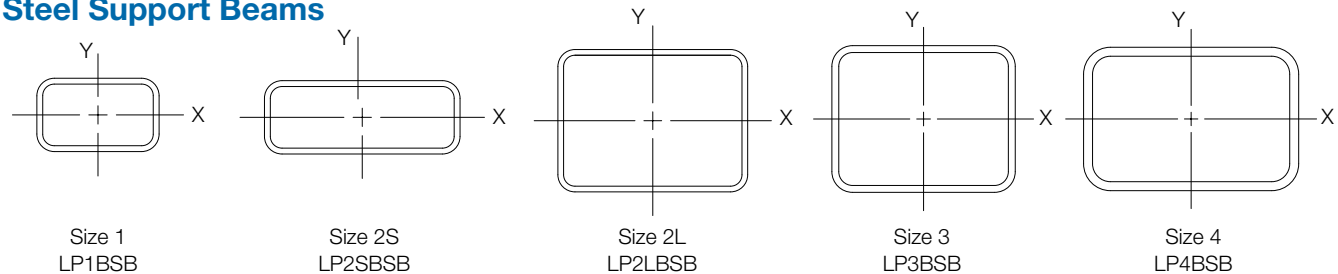

Size	Width	Height	Thickness	Cross Sectional Area	Moment of Inertia X-Axis	Moment of Inertia Y-Axis	Max Length ¹
1	63.5mm 2.50in	38.1mm 1.50in	3.1mm .12in	541.0mm ² .84in ²	1.215x10 ⁵ mm ⁴ .29in ⁴	2.679x10 ⁵ mm ⁴ .64in ⁴	7.3m 24ft
2S	101.6mm 4.00in	38.1mm 1.50in	3.1mm .12in	774.6mm ² 1.20in ²	1.933x10 ⁵ mm ⁴ .46in ⁴	9.045x10 ⁵ mm ⁴ 2.17in ⁴	12.2m 40ft
2L	101.6mm 4.00in	76.2mm 3.00in	3.1mm .12in	1006.8mm ² 1.56in ²	9.468x10 ⁵ mm ⁴ 2.27in ⁴	1.469x10 ⁶ mm ⁴ 3.53in ⁴	7.3m 24ft
3	127.0mm 5.00in	101.6mm 4.00in	4.8mm .19in	1994.1mm ² 3.09in ²	3.216x10 ⁶ mm ⁴ 7.73in ⁴	4.524x10 ⁶ mm ⁴ 10.87in ⁴	14.6m 48ft
4	152.4mm 6.00in	101.6mm 4.00in	6.4mm .25in	2891.4mm ² 4.48in ²	4.702x10 ⁶ mm ⁴ 11.30in ⁴	8.777x10 ⁶ mm ⁴ 21.09in ⁴	14.6m 48ft

Aluminum beams are 6061-T6 aluminum alloy. Steel beams are structural steel tubing ASTM A500 Grade A. Note: drawings are not to scale.

1. Sizes 3 & 4 - up to 48ft lengths stock. Longer lengths available upon request. Contact factory for availability.

Chain

System Ordering Information: Chain Driven Systems

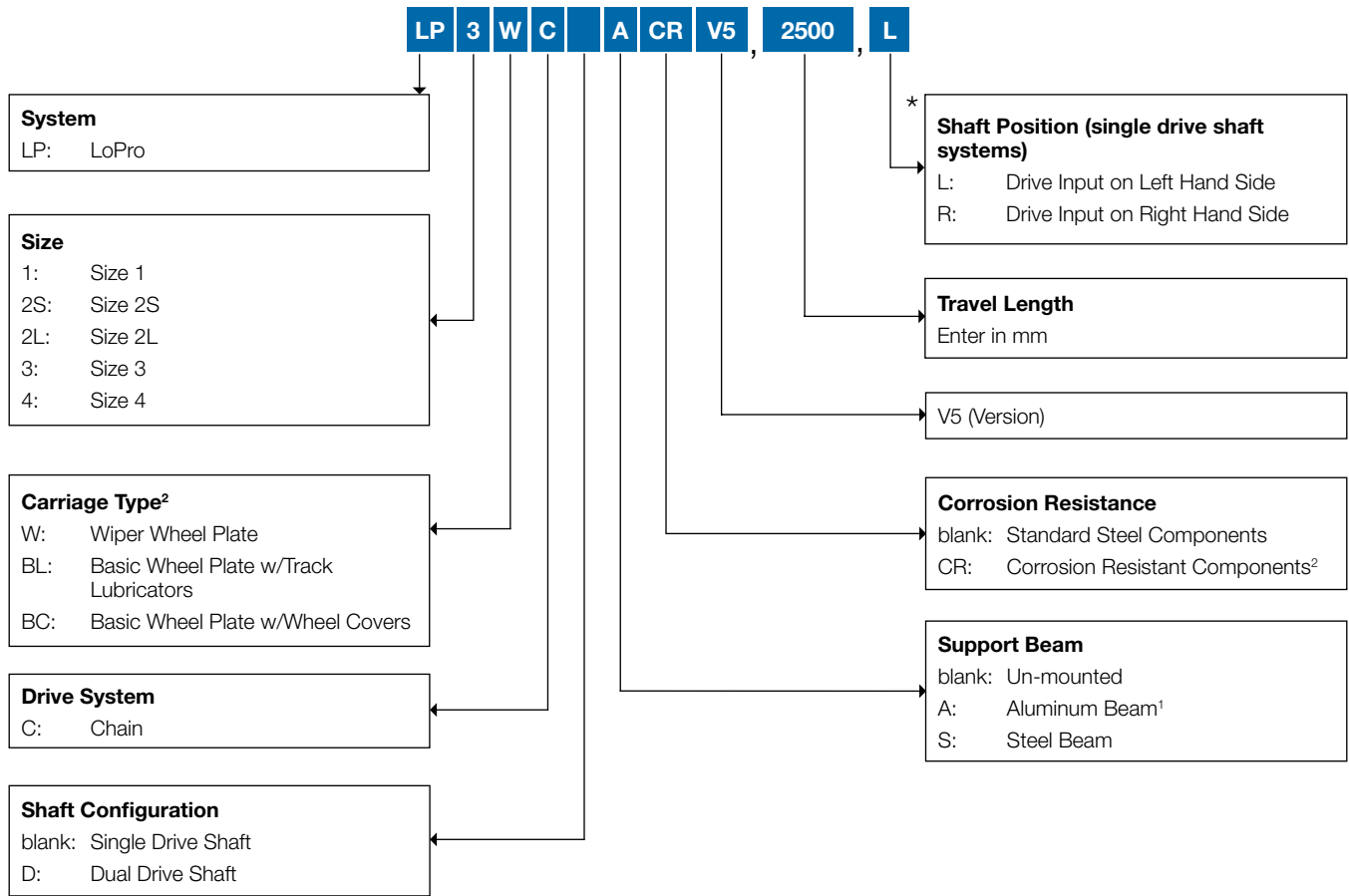

*Shaft Position

Top View (Right Hand Shaft Shown)

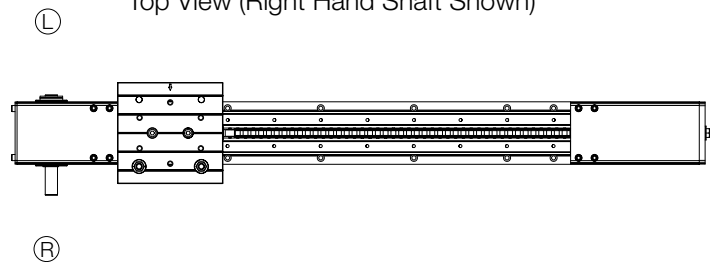

Ordering Examples

Example 1: LP 3 W C (blank) A CR V5, 2500, L = LP3WCACRV5, 2500, L
LoPro Size 3, Wiper Wheel Plate, Chain Driven, Single Shaft, Aluminum Support Beam, Corrosion Resistant, 2500mm Carriage Travel, Shaft Position Left

Example 2: : LP 1 BL C D S (blank) V5, 1000, (blank) = LP1BLCDSV5, 1000
LoPro Size 1, Basic Wheel Plate w/Track Lubricators, Chain Driven, Dual Shaft, Steel Support Beam, Standard Steel Components, 1000mm Carriage Travel

1. Aluminum beam not available on size 4.
2. Corrosion resistant systems are available with wiper wheel plate only. Corrosion resistant systems on stainless steel beams are custom. Contact Bishop-Wisecarver for details.

Track Plate Assemblies

- Provides the lowest profile linear guidance
- Induction hardened, single edge track is available in either carbon steel or stainless steel
- Track plate assemblies are butt-joinable for long stroke requirements
- Lightweight anodized aluminum substrate

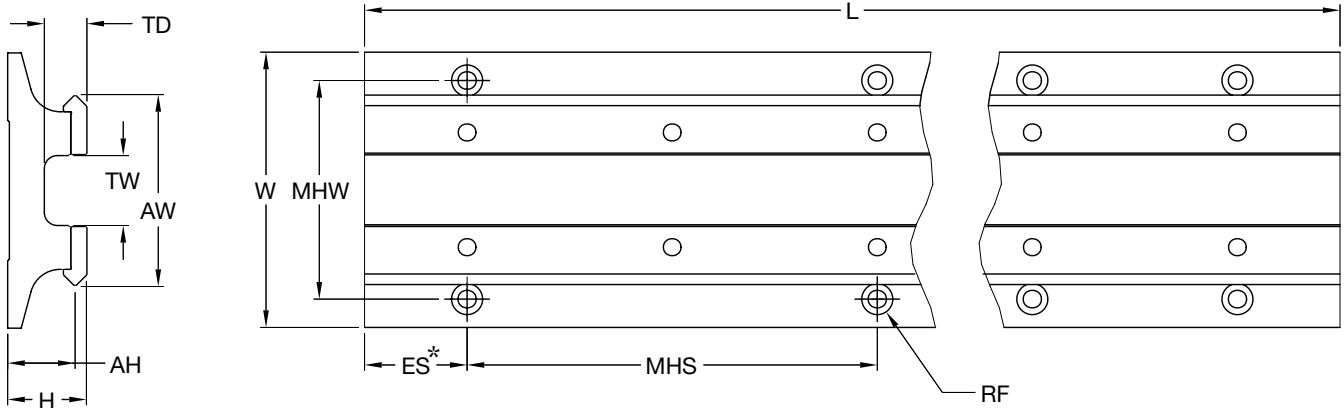
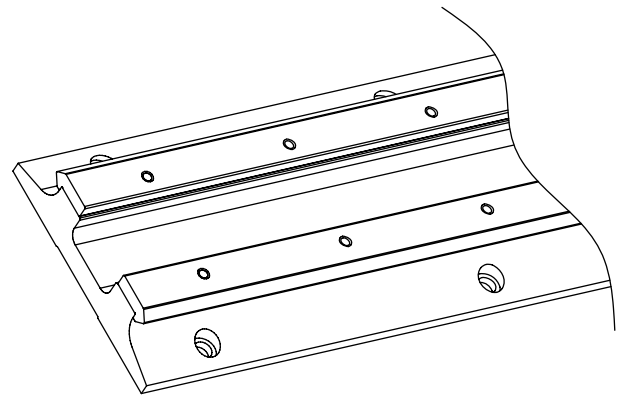

Size	Part Number	Width	Overall Height	Vee Height	Vee Width	Inner Width	Inner Depth	Mounting Hole Width	Mounting Hole Length Space	Mounting Hardware (Low Head Cap Screws)
		W	H	AH	AW	TW	TD	MHW	MHS	RF
1	M1ATP	50.0mm 1.969in	15.9mm .625in	13.5mm .532in	37.4mm 1.473in	12.7mm .500in	9.3mm .365in	40.0mm 1.575in	76.0mm 2.992in	M3
2	M2ATP	72.0mm 2.835in	22.2mm .873in	19.0mm .748in	54.6mm 2.150in	20.3mm .799in	12.9mm .508in	59.0mm 2.323in	126.0mm 4.961in	M5
3	M3ATP	102.0mm 4.016in	29.4mm 1.156in	25.0mm .985in	71.1mm 2.799in	25.9mm 1.020in	15.8mm .622in	81.0mm 3.189in	152.0mm 5.984in	M6
4	M4ATP	140.0mm 5.512in	36.6mm 1.440in	31.0mm 1.222in	95.8mm 3.773in	39.4mm 1.550in	22.9mm .900in	111.0mm 4.370in	178.0mm 7.008in	M8

*ES = End spacing dimension is contingent upon Track Plate Length.

Tools and Accessories

Motor Mounts

- Available to fit **ANY** manufacturer's motor or gearbox
- Supplied as a kit, complete with shaft coupling and mounting hardware
- Two-piece design
- Dual access holes

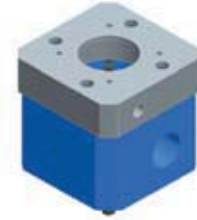

Coupling Options:

Elastomer



- Zero backlash
- Vibration dampening
- Three-piece pluggable design
- Ideal choice where high stiffness is not critical

Bellows



- Zero backlash
- High stiffness (7 to 10 times stiffer than an elastomer coupling)
- High speeds (up to 25,000 rpm)
- Can withstand harsh environments, where glue connections cannot

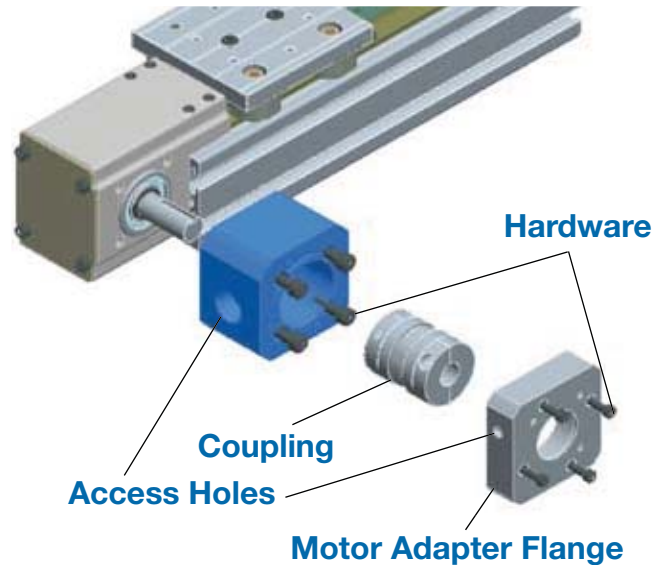

Ordering Information:

LP3BC E 1 K

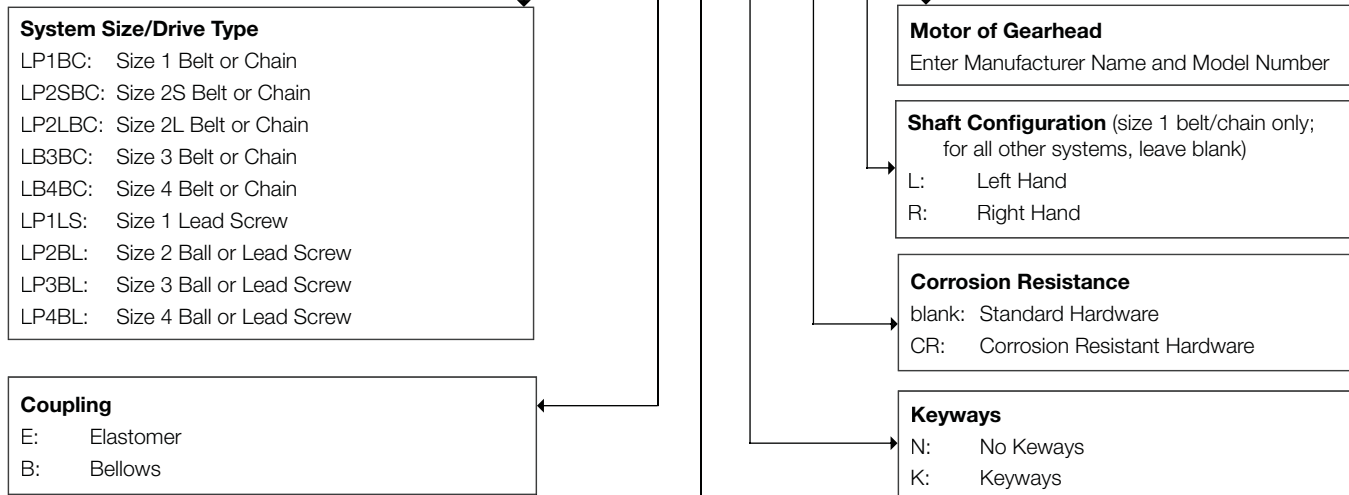

Torque Rating N*m / (Bore Range)					
LP1BC:	Elastomer	Bellows	LP3BC:	Elastomer	Bellows
1:	8 / (8-16mm)	4 / (3-14mm)	1:	60 / (14-29mm)	50 / (15-34mm)
			2:	90 / (.750"-29mm)	--
LP2SBC:	Elastomer	Bellows	LP4BC:	Elastomer	Bellows
1:	8 / (8-16mm)	10 / (8-16mm)	1:	150 / (22-38mm)	100 / (22-38mm)
LP2LBC:	Elastomer	Bellows	LP1LS:	Elastomer	Bellows
1:	30 / (.500"-26mm)	25 / (10-28mm)	1:	5 / (5-8mm)	2 / (3-10mm)
2:	45 / (18-26mm)	--	2:	--	5 / (3-10mm)
			LP4BL:	Elastomer	Bellows
			1:	30 / (.500"-26mm)	40 / (12-28mm)
			2:	45 / (18-26mm)	--

For complete details and dimensions, visit www.bwc.com/products/lopro.html.

Tools and Accessories

Gantry Brackets

A wide variety of gantry brackets are available to form complete LoPro gantry systems. The following compatibility matrix shows which LoPro system sizes can be mated together, and in which orientations.

Additional parts may be required for complete assembly, including mounting plates, carriage screws, and clamp, T-nut or gusset fastening system parts. Please consult Bishop-Wisecarver's applications engineers for additional assistance. In addition, the LoPro gantry system assembly manual is available at www.bwc.com/library_download_documents.php.

Primary Stage System Size	Secondary System Size				
	1	2 ¹ /2S	2L	3	4
1	A, B, C, D	N/A	N/A	N/A	N/A
2	A, B, C, D	A, B, C, D	A, B, C, D	N/A	N/A
3	A, B, C, D	A, B, C, D	A, B, C, D	A, B, C, D	D ³
4	A, B ² , C, D	B ²	B	A, B, C, D	D ³

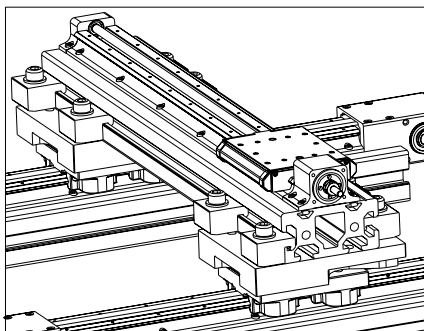

A. X-Y (Horizontal Y Stage)

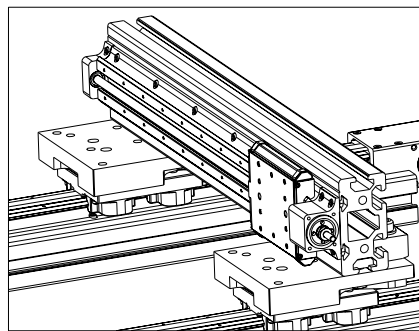

B. X-Y (Perpendicular Y Stage)

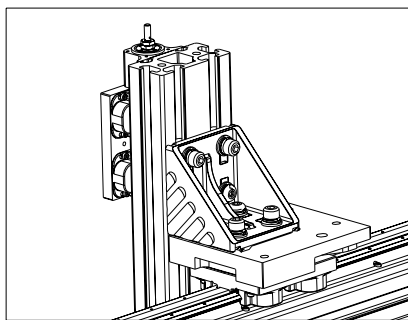

C. X-Z (Z Stage Connected by Support Beam)

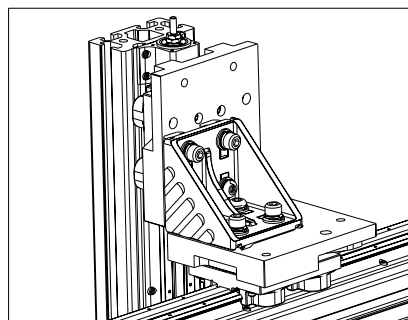

D. X-Z (Z Stage Connected by Carriage)

1. Size 2 lead screw or ball screw system.
2. Size 1 and 2/2S secondary stages can be mounted with T-nuts in the perpendicular orientation on size 4 mounting plates, but cannot have side clamps as reinforcement.
3. Though it is physically possible to connect size 4 systems as secondary stages, this arrangement is not recommended.

Tools and Accessories

Other Accessories

- TURCK Bi 2-Q10S-VN6X inductive proximity sensor – Embeddable rectangular 10mm housing with 2mm sensing range, potted-in cable and 4-wire DC complementary output
- Elastomer line shafts in a variety of lengths and diameters
- Additional custom accessories are available to fit your application needs. Contact our applications engineers for assistance.



Fit-up Wrenches

- Eccentric adjustment mounting tools
- Order bushing wrench and wheel bolt wrench for each wiper wheel plate size (1, 2, 3, and 4)
- For basic wheel plate, use wheel stud wrench and socket wrench to adjust eccentric wheels (socket wrench not supplied)
- Allows for fit-up adjustment between opposing wheels by rotating eccentric bushing

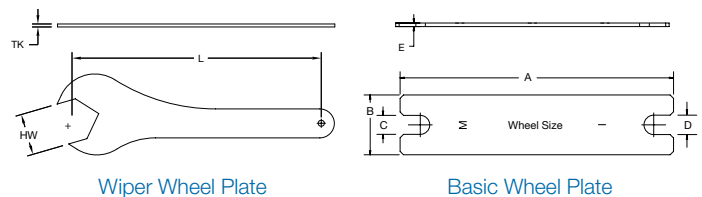

Wiper Wheel Plate

Wrench Type	Size	Part Number	Wrench Size	Length	Thickness
			HW	L	TK
Wheel Bolt	1	1PWRB	5.6mm .220in	101.3mm 3.990in	2.3mm .091in
	2	2PWRB	8.7mm .344in	114.3mm 4.50in	3.0mm .121in
	3	3PWRB	11.2mm .440in	127.0mm 5.00in	3.4mm .140in
	4	4PWRB	12.8mm .503in	138.9mm 5.50in	3.4mm .140in
Eccentric Bushing	1	1PWRX	11.2mm .439in	101.6mm 4.00in	1.8mm .070in
	2	2PWRX	14.3mm .564in	114.3mm 4.50in	2.3mm .090in
	3	3PWRX	19.1mm .752in	129.5mm 5.10in	2.7mm .110in
	4	4PWRX	22.3mm .877in	147.3mm 5.80in	2.7mm .110in

Wheel Stud Wrench

Part #'s	Wheel Size	A	B	C	D	E
WR1MI	1	7.00	1.50	.474-.479	.439-.444	.0747±.0050
WR2MI	2	8.00	1.75	.553-.558	.565-.570	.1046±.0050
WR3MI	3	9.00	2.00	.750-.755	.752-.757	.1345±.0050
WR4MI	4	9.00	2.00	.868-.873	.877-.882	.1345±.0050

Values are in inches. Wrenches are universal for metric and inch.

Technical Reference

Load/Life Relationship

Several factors influence the service life of a LoPro linear motion system. Through research and development spanning over thirty years, Bishop-Wisecarver has devised a simple method to estimate the load/life relationship for a specific DualVee guide mechanism under defined loading conditions. The methodology accounts for the size of the DualVee bearing elements, their relative spacing, and the orientation, location, and magnitude of the load. The formula is based upon clean and well lubricated track conditions; so for applications where lubrication is prohibitive, a derating factor must be applied.

It is important to note that other factors such as maximum velocity, acceleration rates, duty cycle, stroke length, environmental conditions, the presence of shock and vibration, and extreme temperature ranges can all impact service life to varying degrees. As such, the sizing method should be considered only as a guideline for the sizing of DualVee components and assemblies.

Load/Life Equation – Sizing and Selection

The load/life estimation requires a basic understanding of the principles of statics, and the ability to work with free body diagrams. The following life equation is for the purpose of estimating the expected life of the wheel plate and track plate only. System drive components are not accounted for but should also be considered. Drive element load ratings are shown throughout the catalog for each type of system.

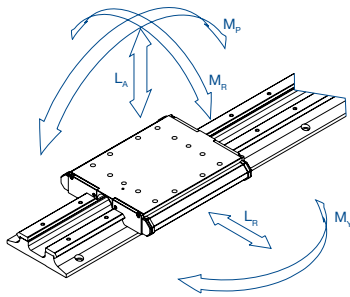

Step 1: Calculate all forces applied to the wheel plate

Any forces applied on the wheel plate need to be considered, including inertial forces, gravitational forces, external forces such as tool pressure, impact loading, and payload. If assistance is required in resolving specific loads into the resultant reaction forces, please contact our Applications Engineering staff for support. It is recommended that the Application Data Sheet on page 57 be submitted beforehand, with as much application information detailed as possible.

Step 2: Calculate the load factor for the wheel plate

$$L_F = \frac{F_R}{F_{R(max)}} + \frac{F_A}{F_{A(max)}} + \frac{M_P}{M_{P(max)}} + \frac{M_Y}{M_{Y(max)}} + \frac{M_R}{M_{R(max)}}$$

Where:

- L_F = Load Factor
- F_R = Applied Radial Load
- F_A = Applied Axial Load
- M_P = Applied Pitch Moment Load
- M_Y = Applied Yaw Moment Load
- M_R = Applied Roll Moment Load

$$L_F \leq 1$$

Carriage Assembly Load Capacities					
System Size	Radial Load Capacity	Axial Load Capacity	Pitch Moment Capacity	Yaw Moment Capacity	Roll Moment Capacity
	$F_{R(max)}$	$F_{A(max)}$	$M_{P(max)}$	$M_{Y(max)}$	$M_{R(max)}$
	N	N	N·m	N·m	N·m
1	2391	988	26	62	27
2/2S/2L	5194	2450	95	202	100
3	11564	6668	346	599	372
4	19012	15684	1220	1478	1174

Step 3: Calculate estimated life with adjustment factor

Due to varying application load and speed parameters and environmental conditions, the appropriate adjustment factor must be applied to the equation on the following page.

Adjustment Factor (A_F)

1.0 – 0.7

0.7 – 0.4

0.4 – 0.1

Application Conditions

Clean, low speed, low shock, low duty

Moderate contaminants, medium duty, medium shock, low to medium vibration, moderate speed

Heavy contamination, high acceleration, high speed, medium to high shock, high vibration, high duty cycle

Oscillating motion resulting in less than one full revolution of the wheel under load can cause accelerated wear on the internal bearing elements. Testing of such systems is recommended to verify compatibility of the design with load/life requirements.

Technical Reference

System Size	Life Constant L_c	
	Inches of Travel Life	Kilometers of Travel Life
1	2.19×10^6	55
2/2S/2L	3.47×10^6	87
3	5.19×10^6	130
4	6.84×10^6	151

$$\text{Life} = \left(\frac{L_c}{(L_f)^3} \right) A_f$$

Where: L_f = Load Factor

L_c = Life Constant

A_f = Adjustment Factor

Accuracy/Repeatability

The accuracy of a LoPro linear system is dependent upon the mounting surface preparation and the technique used to align the track. LoPro systems can achieve straightness and flatness characteristics to within .004in/foot (0.1mm/300mm) when mounting surfaces are adequately prepared. Straight line accuracy of beam mounted LoPro systems are subject to the industry standard straightness and twist tolerances associated with extruded or hot formed sections. As such, the highest straight line precision can be achieved by bolting an unsupported LoPro system to a carefully prepared flat mounting surface. Use of a machined reference edge will help maximize system straightness.

Fit Up Adjustment

The concentric bushings/wheels determine the alignment of the system. They should carry as much of the load as possible. The system should be such that the load is predominantly supported by the wheels radially whenever possible.

Normal adjustment is obtained by rotating the eccentric bushings until all free play is removed from the carriage assembly. When the eccentrics are adjusted and the carriage plate is held firmly in place, one should be able to rotate, by hand, any of the four guide wheels in the system against its mating track. If rotation is not possible, preload on the wheels should be reduced accordingly. Over-tightening of the eccentric adjustment could result in premature bearing failure. Such a condition can exert a force greater than the load rating of the wheel.

Lubrication

Lubrication is the key to maximizing service life in any rolling contact linear bearing design. Internally, DualVee guide wheels are lubricated for life with an extreme pressure, corrosion resistant grease. As such, the main consideration with regards to lubrication is the wheel/track interface. Typically, a light machine oil or an extreme pressure grease does well to minimize wear, stick slip, and corrosion.

LoPro systems are available with two standard wheel plate designs. The wiper wheel plate comes complete with lubricating wiper caps (lubricators consist of an oil saturated felt). The basic wheel plate is available with either wheel covers or track lubricators. Both options include lubrication via oil saturated felt.

Lubrication will maximize the load capacity of an individual bearing element. As such, for any specific loading condition, the presence of lubrication on the guide ways will significantly increase the service life over a non-lubricated configuration under the same loads.

Lubrication will also increase the maximum linear velocity that a guide wheel-based bearing arrangement can travel. In high cycling applications where high speed or acceleration rates are present, lubrication of the wheel/track interface is strongly recommended.

LoPro System Mass Calculation

The following calculations are approximate, and depict the maximum mass (kg) for each size. Exact calculations will vary depending on system configuration.

Beam Mounted

Size	Actuator Type			
	Belt	Chain	Lead Screw	Ball Screw
1	$6.3xL + 1.7$	$6.5xL + 1.8$	$6.4xL + 1.2$	N/A
2	N/A	N/A	$9.8xL + 2.8$	$9.9xL + 2.8$
2S	$9.4xL + 4.1$	$9.9xL + 4.3$	N/A	N/A
2L	$11.3xL + 7.0$	$11.7xL + 7.5$	N/A	N/A
3	$21.9xL + 14.6$	$22.8xL + 15.7$	$23.1xL + 7.7$	$22.4xL + 7.7$
4	$32.6xL + 26.3$	$34.3xL + 27.4$	$25.7xL + 13.6$	$25.9xL + 13.6$

Un-Mounted

Size	Actuator Type			
	Belt	Chain	Lead Screw	Ball Screw
1	$1.7xL + 1.0$	$1.9xL + 1.1$	$1.9xL + 0.6$	N/A
2	N/A	N/A	$3.8xL + 1.6$	$3.8xL + 1.7$
2S	$3.3xL + 2.8$	$3.9xL + 3.1$	N/A	N/A
2L	$3.4xL + 5.3$	$3.9xL + 5.8$	N/A	N/A
3	$6.4xL + 10.3$	$7.3xL + 11.4$	$7.6xL + 4.1$	$6.9xL + 4.1$
4	$10.1xL + 18.3$	$11.7xL + 19.4$	$12.0xL + 9.1$	$12.2xL + 9.1$

L = Carriage Travel Length (m)

Custom Engineered Linear Motion Systems

In addition to the standard line of LoPro linear system products, Bishop-Wisecarver's capabilities extend beyond these standard systems and into the realm of custom engineered products. Custom engineered solutions from Bishop-Wisecarver range from slight modifications made to standard systems to complete ground-up system designs using DualVee components and/or linear guides.

Value added modifications and capabilities include but are not limited to:

- Multi-axis/Gantry Bracketry
- Limit Switches
- Gearboxes
- Elastomer or Bellows Couplings
- Connecting Shafts
- Bellows
- Foot Mounts for Steel Support Beams
- Special Machining
- Track Plating Options
- Custom Wheel Plate Designs
- Custom Design Assistance
- Assembly Services (prior to shipping)

Custom engineered products are typically designed in collaboration with the customer's design team, taking into account the major design parameters including envelope restrictions, material considerations, accuracy, repeatability, thrust requirements, duty cycle, and service life objectives. Non-recurring engineering fees may apply depending on the level of customization involved. Typical projects entail varying levels of prototype sketching, detailing, and prototype design modification as the system specifications are refined. Prior to fabrication, prototype designs are formally detailed and documented for "sign-off" approval by the customer. JIT and Kanban-type arrangements can be accommodated for custom engineered OEM requirements.



This custom LoPro linear guidance system's X-axis uses custom carriage assemblies consisting of eight size 4XL (extra large) DualVee wheels and steel wheel plates rather than the standard size 4, four-wheel aluminum wheel plate assemblies. Each assembly is capable of loads in excess of 7,500 lbs. The Z-axis, with lift capacities of more than 5,000 lbs., features special chain couplers with a leaf chain drive mechanism and solid steel idler sheave with high capacity roller bearings mounted on a steel housing structure.

APPLICATION DATA SHEET

Company: _____
 Contact: _____
 Address: _____

City: _____ State: _____ Zip Code: _____
 Phone: _____ Fax: _____ e-mail: _____

System Orientation: _____	horizontal		vertical	
Load: _____	lbs		N	
Stroke Length: _____	in		m	
Velocity: _____	in/s		m/s	
Accel/Decel: _____	in/s ²		m/s ²	
Linear Accuracy: _____	in/ft		mm/m	
Repeatability: _____	in		mm	
Duty Cycle: _____	in/day		m/day	
Environment: _____	factory	food grade	clean room	other
Temperature: _____	°F		°C	
Additional Forces: _____	lbs		N	

Product/Machine Description: _____

Additional Requirements: _____

Expected Volume: _____ Date Needed: _____

System Sketch

BISHOPWISECARVER®

2104 Martin Way, Pittsburg, CA 94565
 phone: 925.439.8272 fax: 925.439.5931
 info@bwc.com www.bwc.com

Bishop-Wisecarver Corporation: Manufacturer of the original DualVee® guide wheel and industry leader in guided motion technology, and exclusive North and Central American partner and distributor for HepcoMotion products since 1984.

BISHOPWISECARVER®

Bishop-Wisecarver

DualVee® Guide Wheels
LoPro® Linear Motion System
MadeWell® Crown Rollers
MinVee® Linear Slide System
SRX-150 Linear Motion System
UtiliTrak® Linear Motion Guide



HepcoMotion®

DAPDU2 Double Acting Profile Driven Unit
DLS Driven Linear System
DTS Driven Track System
GV3 Linear Guidance and Transmission System
HDCB Heavy Duty Compact Beam
HDCS Heavy Duty Compact Screw
HDLS Heavy Duty Driven Linear System
HDRT Heavy Duty Ring Slides and Track System
HDS Heavy Duty Slide System
MHD Heavy Duty Track Roller Guidance System
MCS Machine Construction System
PDU2 Profile Driven Unit
PRT Precision Ring and Track System
PSD120 Profile Screw Driven Unit
SBD Sealed Belt Drive
Simple-Select®
SL2 Stainless Steel Based Slide System

3D CAD DRAWINGS

Download 3D CAD files for our complete product line at www.bwc.com/3dcad.php.

GOT A TOUGH APPLICATION CHALLENGE?

Ask Bud at www.bwc.com/blog/?cat=11.

PRODUCT ORDERS

Please call Bishop-Wisecarver with your specific application requirements. Our technical staff is available to assist with your custom solution.

Bishop-Wisecarver provides a written one year limited warranty assuring the customer that its products conform to published specifications and are free from defects in material or workmanship.

Complete terms and conditions and warranty information is available at www.bwc.com/about_conditions.vp.html

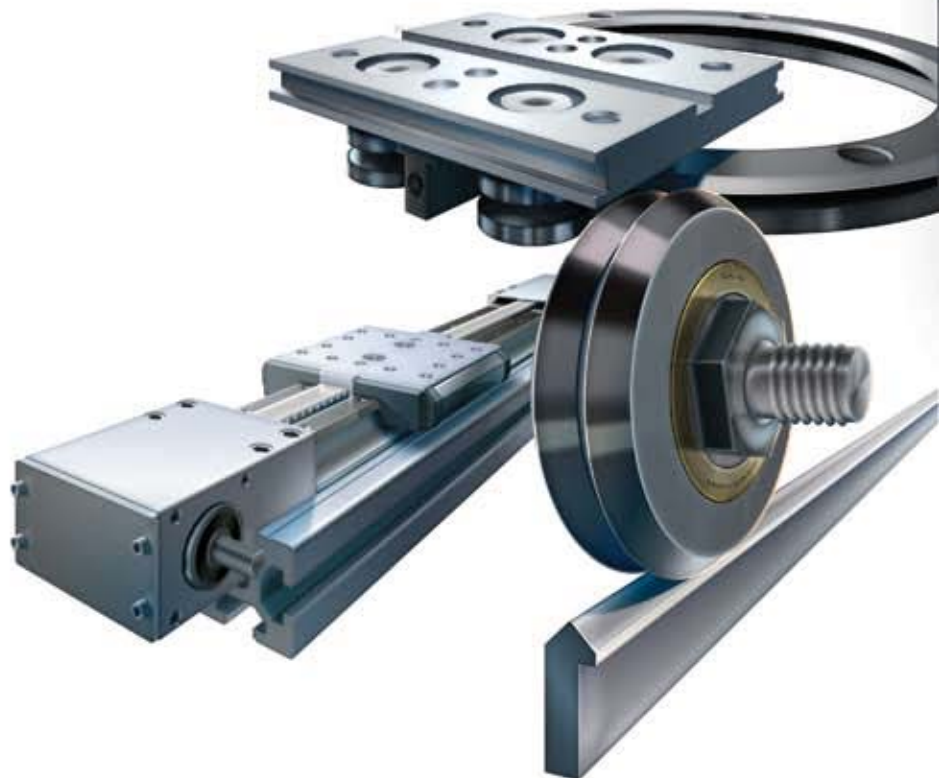

888.580.8272 925.439.8272 www.bwc.com