

AccuDrive Family of Products



Series W



Series P



Model RG



Series E



CONEDRIVE
GEARING SOLUTIONS

ACCUDRIVE PRECISION PRODUCTS

Now you can get design flexibility and lasting performance from our complete family of AccuDrive Precision Products.

Series W Precision Servo Gearhead

Output torque up to 8,500 lb.in.
Motor adapters to fit servo motors.
Center distance from 38 to 89 mm.
Speed range up to 6,000 RPM input.
Sizes available 38, 51, 64, 76 and 89.
Universal Mounting with shaft mount and flange mount standard.
Gear ratios from 5:1 to 60:1, special ratios available.
Standard backlash, low backlash and ZERO backlash available.



Series P In-line Planetary Servo Gearhead

Output torque capacity up to 15,930 lb.in.
Motor adapters to fit servo motors.
Center distance from 70 to 190 mm.
Speed range up to 10,000 RPM input.
Sizes available 70, 90, 115, 142 and 190.
Gear ratios from 3:1 to 40:1 available from stock.
Universal Mounting with shaft mount and flange mount standard.
Three arcminutes backlash or better.



Series E In-line Planetary Servo Gearhead

Output torque capacity up to 7,080 lb.in.
Motor adapters to fit servo motors.
Center distance from 40 to 160 mm.
Speed range up to 10,000 RPM input.
Sizes available 40, 60, 90, 115, 130 and 140.
Gear ratios from 3:1 to 64:1 available from stock.
Universal Mounting with shaft mount and flange mount standard.
Backlash as low as eight arcminutes.



Model RG Right Angle Gearhead

Output torque capacity up to 8,500 lb.in.
Motor sizes (standard), adapters to fit servo motors, NEMA and IEC.
Center distance from 1.5 to 3.5 inches.
Input power ratings up to 27 H.P, speed range up to 4,000 RPM.
Sizes available 15, 20, 25, 30 and 35.
Universal Mounting with shaft mount and flange mount standard in single reduction type.
Gear ratios from 5:1 to 60:1.



ABSOLUTE ZERO Backlash AccuDrive Gearing

Unique design captures both sides of the gear tooth to completely eliminate backlash. Automatically compensates for wear-guaranteed zero backlash for the life of the gearset. Available for single, double and triple reduction types, loose gearing, special designs and the Series W.





Page

When engineers look for a servo rated gear head to deliver reliability or positional accuracy they look to Cone Drive. From true zero backlash now to the new Series S, Cone Drive continues to meet the needs of the servo control market.

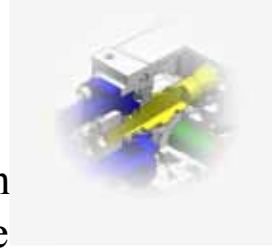

Product Features 2

We are proud to introduce the Series S to our AccuDrive family of servo rated gear heads. The Series S was developed by our customers looking for a highly flexible yet value-priced servo rated gear head without sacrificing performance or durability. The Cone Drive brand is well known for quality and performance, the Series S has been tested and designed to ensure your expectations are met.



Model Number Example 3



Model Number 4 - 9

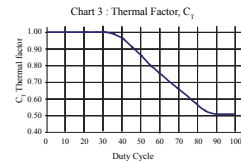

Product Performance 11 - 13

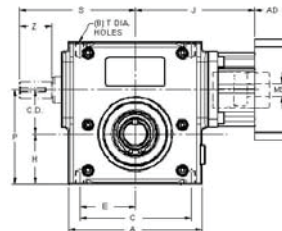

Ratios, Reducer Selection & Drawings 14 - 17



Ratio	Warm Shaft Speed (RPM)					
	500	1000	2000	3000	4000	
5:1	Output Torque, lbf-in	601	1202	1803	2404	3005
	Output Torque, N-m	83.2	166.4	249.6	332.8	416.0
7.5:1	Output Torque, lbf-in	732	1464	2196	2928	3660
	Output Torque, N-m	102.6	205.2	307.8	410.4	513.0
10:1	Output Torque, lbf-in	480	960	1440	1920	2400
	Output Torque, N-m	66.7	133.4	200.1	266.8	333.5
15:1	Output Torque, lbf-in	320	640	960	1280	1600
	Output Torque, N-m	44.4	88.9	133.4	177.8	222.2

Ratings Tables 18 - 23

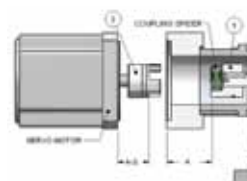

Installation & Operation 24 - 25

Customer Benefits

The Series S is a servo rated speed reducer featuring Conex Gearing and lightweight aluminum construction. Each unit comes filled with synthetic oil and servo motor ready.



Conex Gearing

Cone Drive offers the most advanced worm gearing design with Conex™ technology. The multiple tooth contact means higher load capacity resulting in smaller sizes or increased durability.

Interchangeable

Drops in against most U.S. manufactured worm reducers. Simply changeover to a servo rated reducer for your Category 3 packaging needs.

Aluminum Construction

The all-aluminum construction offers weight savings of up to 30% with improved thermal horsepower over cast iron. The smooth housing design and IP55 rating is ideal for washdown applications.

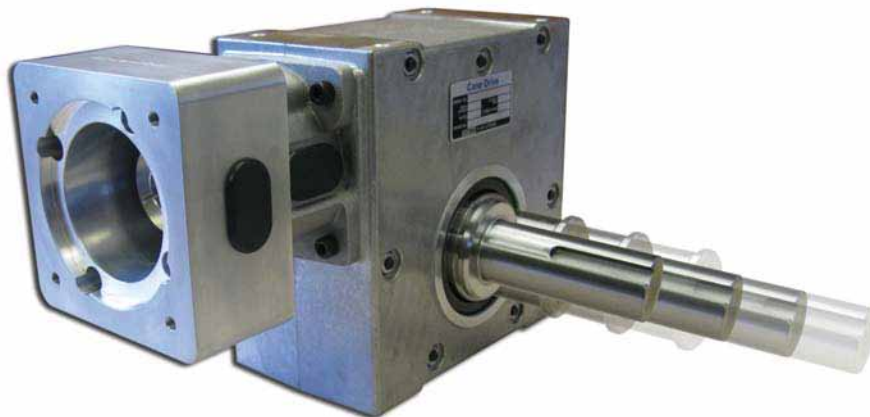

Flexibility

The Series S reduces your costs and lead times with its highly flexible design. Standard with large hollow bores, simply plug-in your output shaft or mount the reducer in any configuration with the vent-free design.

Example Selection:

Speed reducer ratio is 15:1, driven by a servo motor with a continuous rating of 1.5 Nm at 2,000 RPM, peak torque of 3.6 Nm. Motor has a pilot diameter of 80mm, shaft diameter of 16mm, shaft length of 40mm, flange square of 89.4 mm and four 7 mm through holes on a 100 mm bolt circle diameter. Require a double extend solid output with mounting feet.

1	S	
2	0	Positions 2 and 3 represent the reducer size chosen using selection process on pages 12 - 13. Sizes available include S02, S03, S05, S06, S09 and S11.
3	3	
4	0	Position 4 is zero and designates the revision level.
5	1	Positions 5 - 7 are reserved for the ratio. See page 4 for the ratio range. Standard ratios include 5, 7.5, 10, 15, 20, 25, 30, 40, 50, and 60.
6	5	
7	.	
8	S	Position 8 is always the letter "S" and designates the reducer is to fit to a servo motor.
9	B	Position 9 is the unit version, the letter "W" requires no feet and the letter "B" requires feet.
10	S	Position 10 designates when the unit is sold with or without a coupling.
11	P	Position 11 determines the type of output as shown on page 5.
12	A	Position 12 is the motor continuous operation speed.
13	0	Positions 13 and 14 define the installation position of the unit when the unit is mounted as worm (motor) over the output shaft. See page 6.
14	3	
15	M	Positions 15 - 19 represent the servo motor interface dimensions.
16	G	Position 15 is the servo motor flange square and motor shaft length (from the pilot). Position 16 is the motor pilot diameter.
17	K	Position 17 is the motor mounting hole bolt circle diameter.
18	C	Position 18 is the size of the holes in the servo motor flange.
19	J	Position 19 is the motor shaft diameter.
20	-	Position 20 is for special features or white epoxy paint. Use a "-" for no special features.

Pages 4 through 8 describe the letters necessary to build your Series S model number.

Positions 2 & 3: Gear Head Size

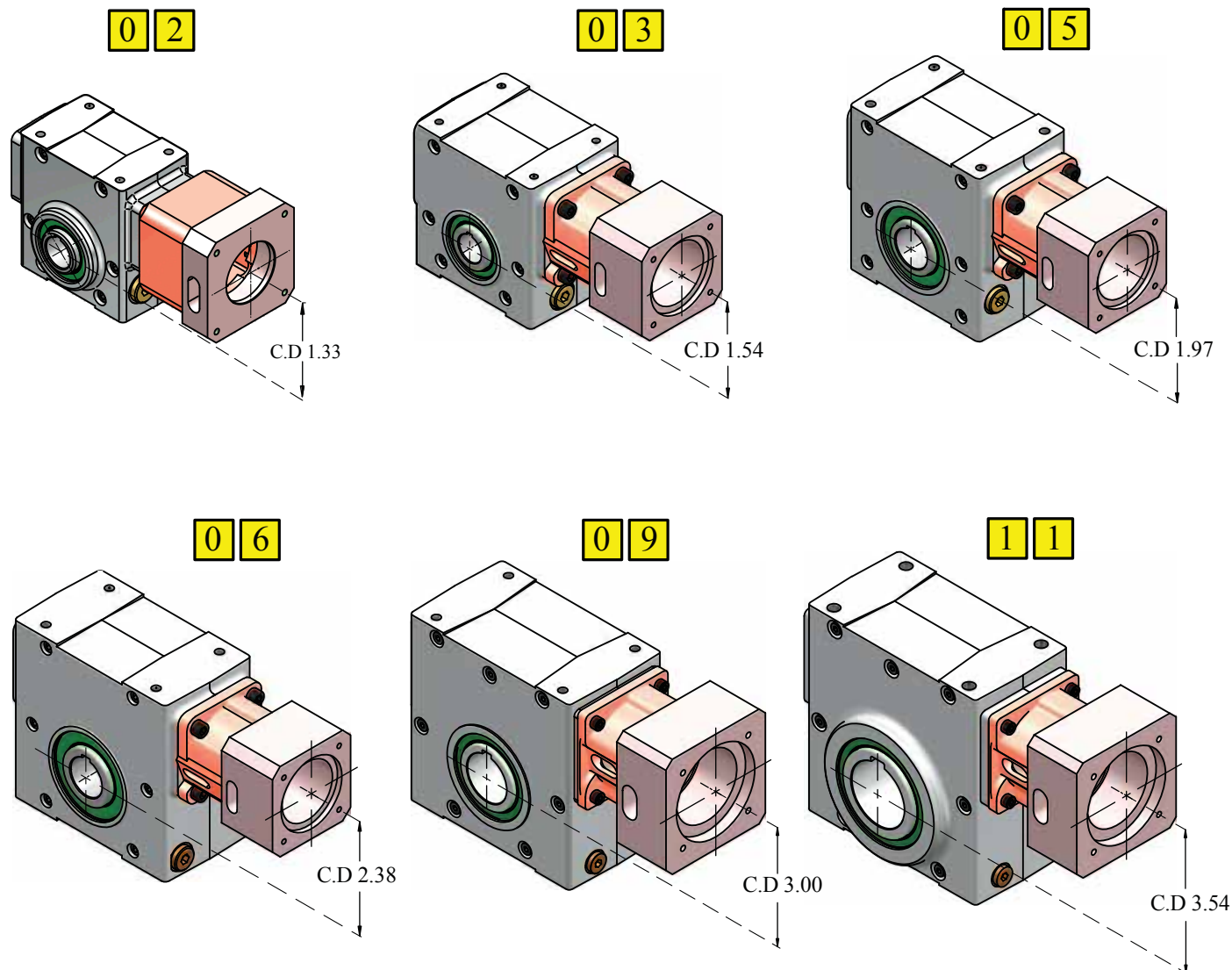

Position 4: Revision Level

0 Revision Level

Position 5, 6 & 7: Gear Head Ratio

Ratio	5:1	7.5:1	10:1	15:1	20:1	25:1	30:1	40:1	50:1	60:1
Column Entry	5 . 0	7 . 5	1 0 .	1 5 .	2 0 .	2 5 .	3 0 .	4 0 .	5 0 .	6 0 .

Position 8: Servo Reducer

S servo reducer

1	2	3	4	5	6	7	8	9	10	11	12	13	14	15	16	17	18	19	20	
S	0	3	0	1	5	.	S													

Position 9: Unit Version

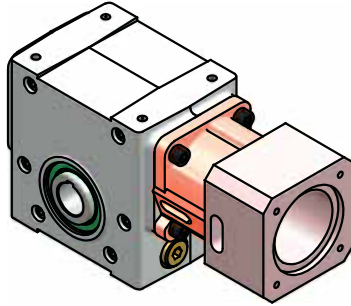

W Standard unit

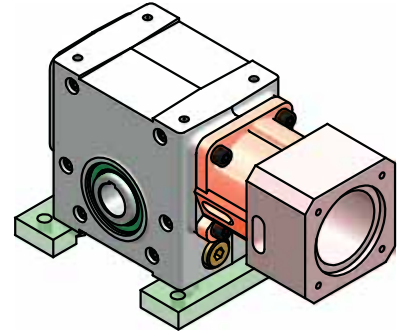

B Unit with Feet

Position 10: Type of Unit

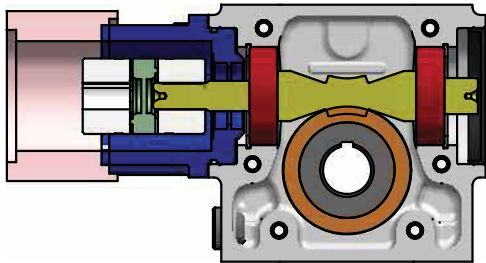

S Unit with Coupling

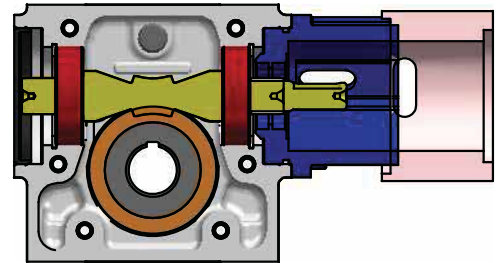

L Unit Less Coupling

Position 11: Output Shaft Options

N Solid Single Extended

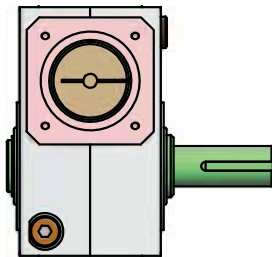

P Solid Double Extended

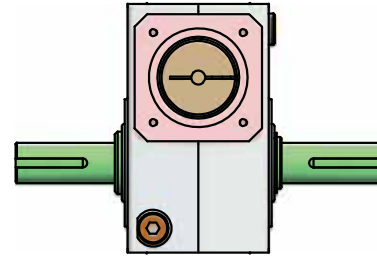

A Hollow

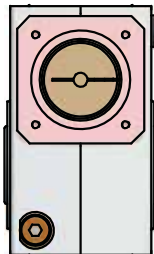

1	2	3	4	5	6	7	8	9	10	11	12	13	14	15	16	17	18	19	20
---	---	---	---	---	---	---	---	---	----	----	----	----	----	----	----	----	----	----	----

S	0	3	0	1	5	.	S	B	S	P										
---	---	---	---	---	---	---	---	----------	----------	----------	--	--	--	--	--	--	--	--	--	--

Position 12: Maximum Input Speed

A	0 - 1000	* S09 & S11 limited to 3,000 RPM
B	1001 - 2000	
C	2001 - 3000	
D	3001 - 4000*	

Position 13 & 14: Assembly Position

Single Extended Input

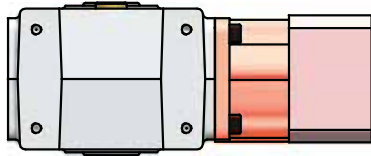

Double Extended Input

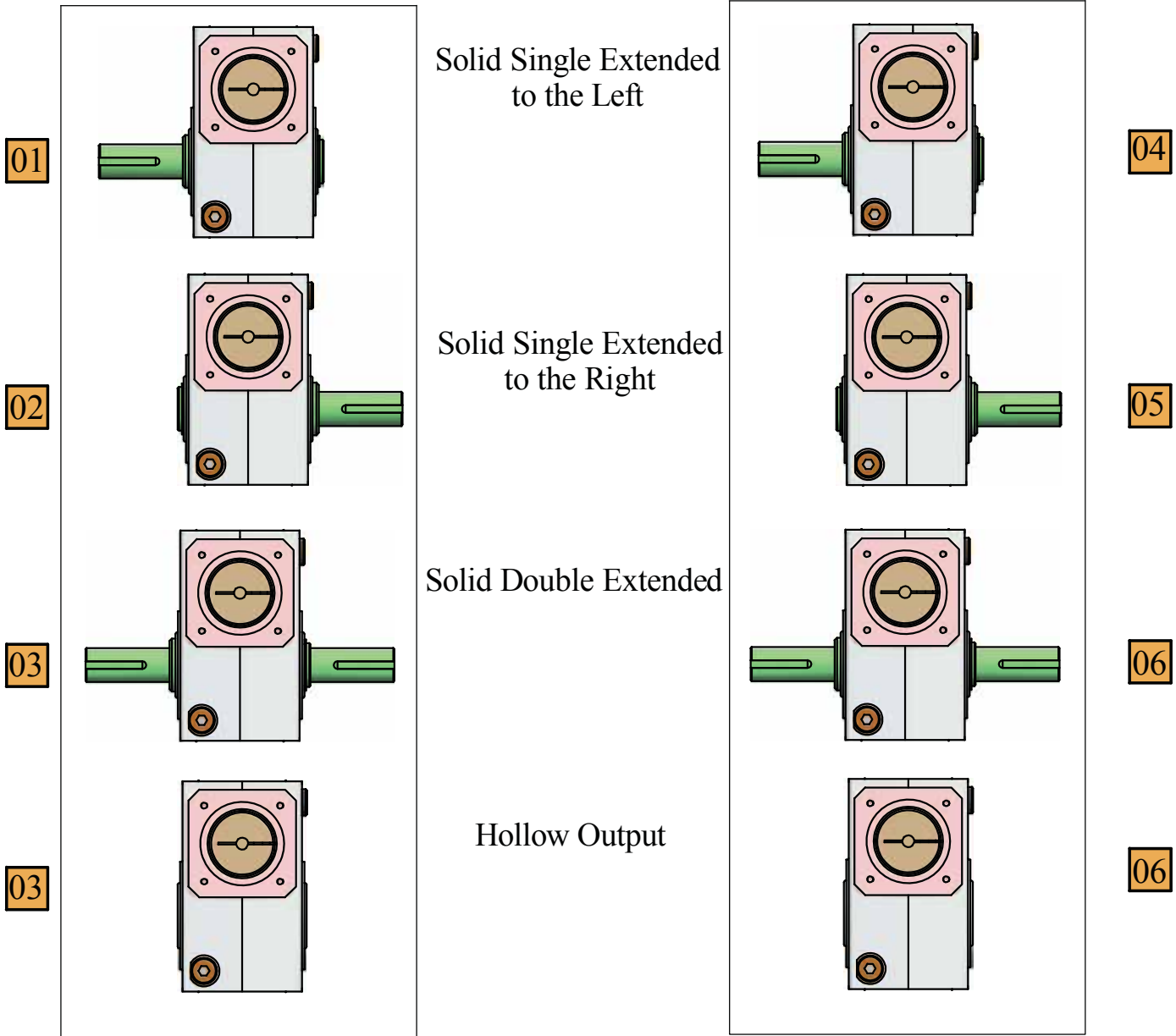
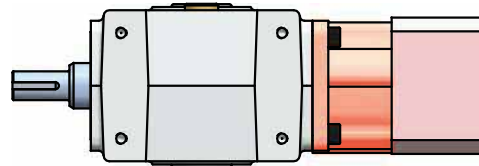

1	2	3	4	5	6	7	8	9	10	11	12	13	14	15	16	17	18	19	20
S	0	3	0	1	5	.	S	B	S	P	A	0	3						

Position 15: Motor Flange Square and Motor Shaft Length

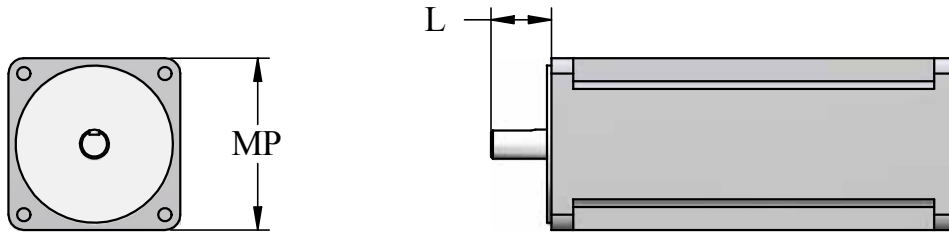

S02

Column 15 Entry	Flange Square (mm)		90			115		
	Dim 'AD' inches (see p.10 and 11)		1.03	1.72	2.31	1.03	1.72	2.31
	Acceptable Motor Shaft Length		22-30	31-49	50-65	22-30	31-49	50-65
	"Unit Size"	S02	B	M	Q	C	D	U

S03, S05 and S06

Column 15 Entry	Flange Square		90			115			130			140	
	Dim 'AD' inches (see p.15 and 16)		1.03	1.72	2.31	1.03	1.72	2.31	1.72	2.03	2.03	2.03	2.62
	Acceptable Motor Shaft Length		22-30	31-49	50-65	22-30	31-49	50-65	40-47	48-55	56-73	48-55	56-73
	"Unit Size"	S03, S05, S06	B	M	Q	C	D	U	E	F	V	G	W

S09 and S11

Column 15 Entry	Flange Square (mm)		115		140		190		
	Dim 'AD' inches (see p.15 and 16)		1.20	1.73	1.93	2.72	1.93	2.32	3.11
	Acceptable Motor Shaft Length		20-32	33-60	38-56	57-80	38-53	54-65	68-85
	"Unit Size"	S09, S11	C	D	G	H	K	S	T

Position 16: Motor Pilot Diameter

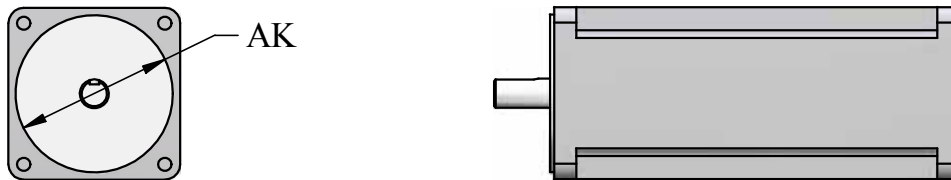

S02, S03, S05 and S06

Column 16 Entry	Motor Pilot Diameter (mm), AK												
	38.15	40	50	55.55	60	70	73.07	80	95	110	114.3	130	
	A	B	C	N	D	E	F	G	H	J	K	L	

S09 and S11

Column 16 Entry	Motor Pilot Diameter (mm), AK					
	80	95	110	114.3	130	180
	G	H	J	K	L	M

1	2	3	4	5	6	7	8	9	10	11	12	13	14	15	16	17	18	19	20
S	0	3	0	1	5	.	S	B	S	P	A	0	3	M	G				

Position 17: Motor Bolt Circle Diameter

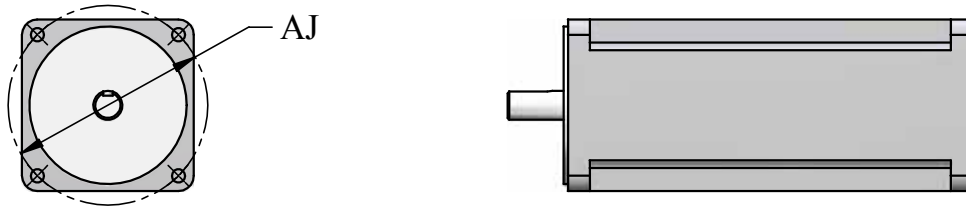

S02, S03, S05 and S06

Column 17 Entry	Bolt Circle Diameter (mm), AJ																
	63	65	66.68	70	75	80	85	90	95	98.43	100	115	125.73	130	145	149	165
	A	B	C	D	E	F	U	G	H	J	K	L	T	M	N	P	Q

S09 and S11

Column 17 Entry	Bolt Circle Diameter (mm), AJ							
	100	115	130	145	149.23	165	200	215
	K	L	M	N	P	Q	R	S

Position 18: Motor Hole Size

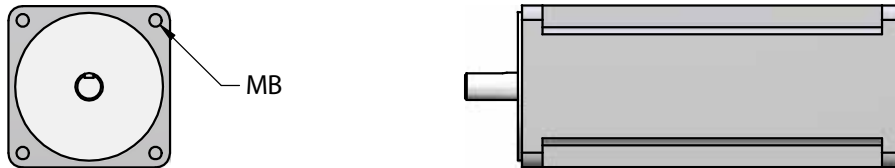

S02, S03, S05 and S06

Column 18 Entry	Motor Flange Thru Hole Size MB	4.5 - 5.2		5.3 - 6.3		6.4 - 8.3		8.4 - 10.3		10.4 - 12.4	12.5 - 15.0
		A		B		C		D		E	F
	Motor Flange Tapped Holes MB	M4	M5	M6	M8	M10	M12	1/4 - 20	3/8 - 16	1/2 - 13	
G		H	J	K	L	M	N	P	Q		

S09 and S11

Column 18 Entry	Motor Flange Thru Hole Size MB	6.4 - 8.3		8.4 - 10.3		10.4 - 12.4		12.5 - 15.0	
		C		D		E		F	
	Motor Flange Tapped Holes MB	M6	M8	M10	M12	1/4 - 20	3/8 - 16	1/2 - 13	
J		K	L	M	N	P	Q		

1 2 3 4 5 6 7 8 9 10 11 12 13 14 15 16 17 18 19 20

S 0 3 0 1 5 . S B S P A 0 3 M G K C

Position 19: Motor Shaft Diameter

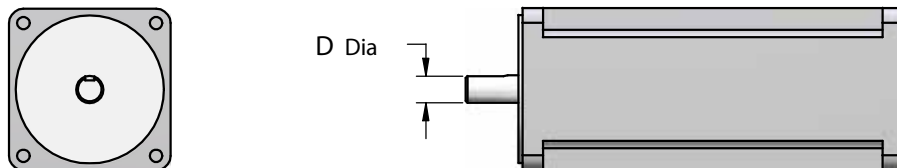

S02, S03, S05 and S06

Column 19 Entry	Motor Shaft Diameter (mm), D													
	9.525	11	12	12.7	14	15.875	16	19	19.05	22*	22.225*	24*	25.4*	28*
B	D	E	F	G	H	J	K	L	M	N	P	Q	R	

*S06 only

S09 and S11

Column 19 Entry	Motor Shaft Diameter (mm), D																
	14	15.875	16	19	19.05	22	22.225	24	25.4	28	28.575	31.75	32	34.925	35	38 *	42 *
G	H	J	K	L	M	N	P	Q	R	S	T	U	V	W	X	Y	

*S11 only

Position 20: Reducer Special Features

-	None
W	White epoxy paint

1	2	3	4	5	6	7	8	9	10	11	12	13	14	15	16	17	18	19	20
S	0	3	0	1	5	.	S	B	S	P	A	0	3	D	C	G	C	J	-

Engineering and Design Data

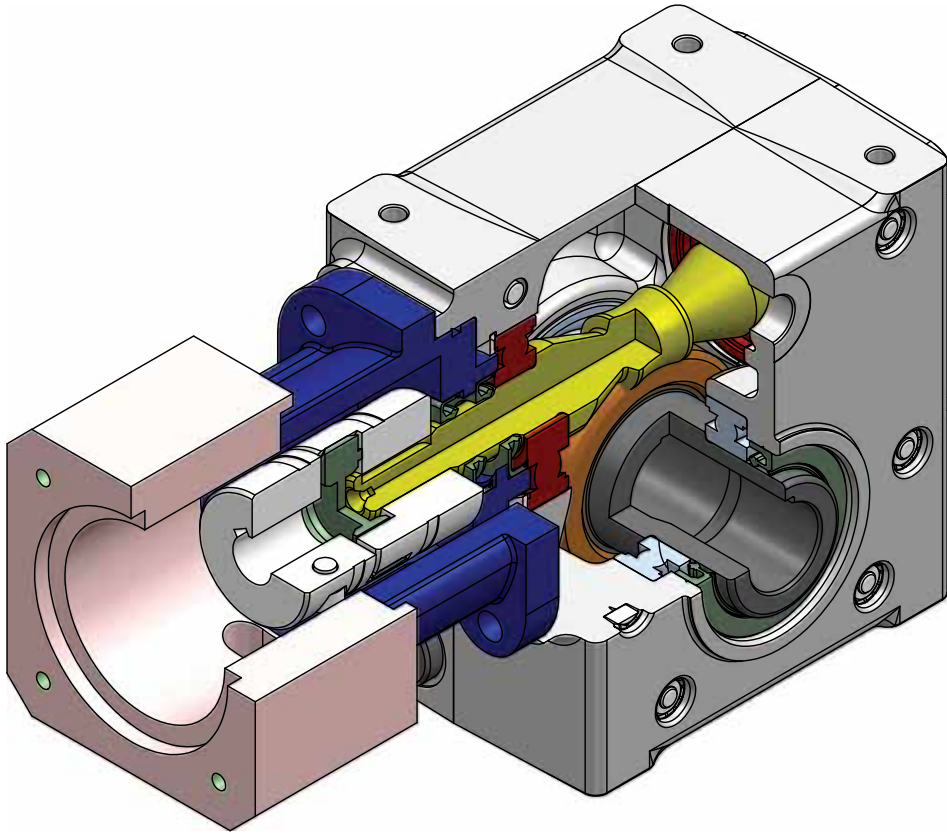

Definitions:

M_G = Ratio

T_w = Torque at the Worm (in-lb)

T_G = Torque at the Output (in-lb)

WK^2 = Inertia (lb-ft²)

n = Rotational Speed (rpm)

η = Efficiency

P = Horsepower (HP)

Horsepower and Torque Calculations :

$$\text{Horsepower} = \frac{(T_G)(n)}{(63000)(M_G)(\eta^*)}$$

$$\text{Output Torque} = \frac{(P)(63000)(M_G)(\eta)}{n}$$

*For Running Horsepower use Running Efficiency,

$$\text{Efficiency} = \frac{(T_G)(n)}{(63000)(P)(M_G)}$$

$$T_G = (T_w)(M_G)(\eta)$$

$$T_w = \frac{(P)(63000)}{n}$$

$$T_w = \frac{T_G}{(M_G)(\eta)}$$

$$\text{Service Factor} = \frac{\text{Reducer Mechanical HP}}{\text{Motor HP}}$$

Based on nominal motor rating

$$\text{Service Factor} = \frac{\text{Reducer Output Torque}}{\text{Required Output Torque}}$$

Based on load

Reducer Quick Select Charts

2,000 RPM Motor Speed

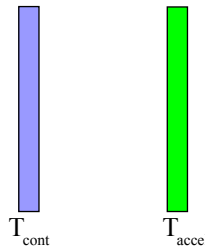
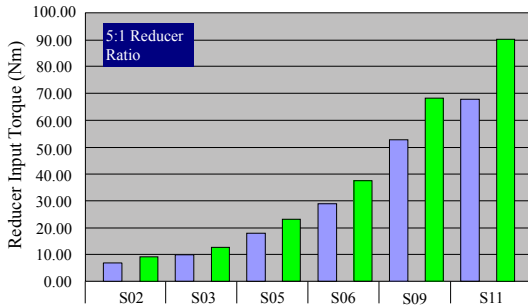

T_{cont} is the reducer's continuous torque rating at 2,000 RPM motor speed

T_{accel} is the reducer's acceleration torque rating at 2,000 RPM motor speed

These charts may be used to quickly select a reducer size and ratio using 2,000 rpm motor speed. Compare the reducer input torque against the servo motor rating. A more thorough evaluation should be made to confirm your selection.

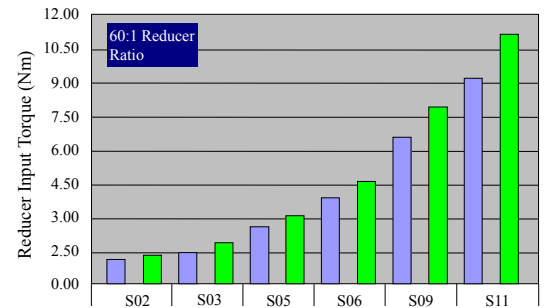
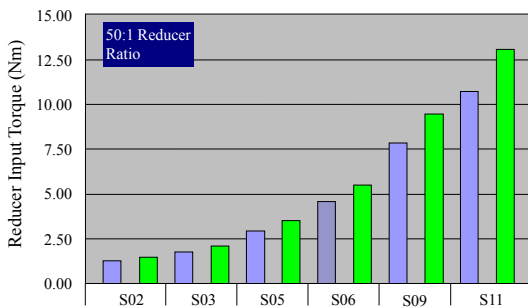
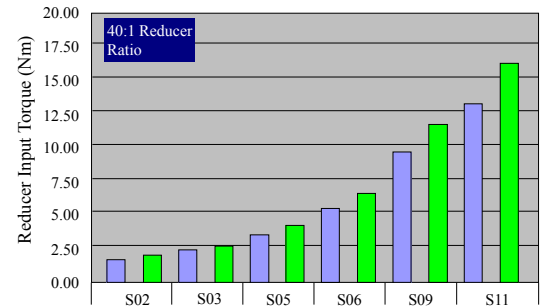
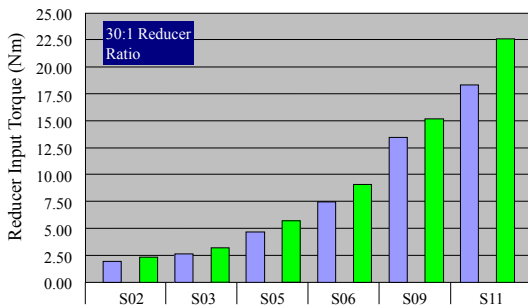
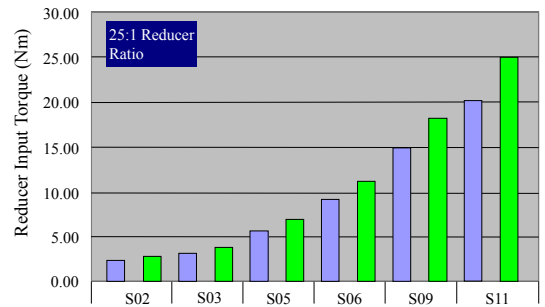
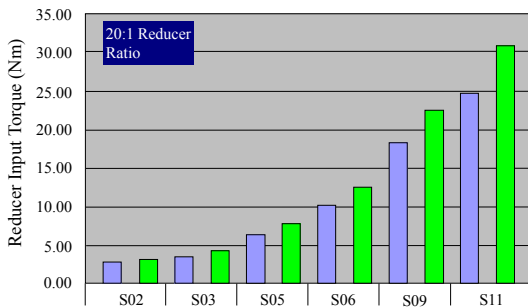
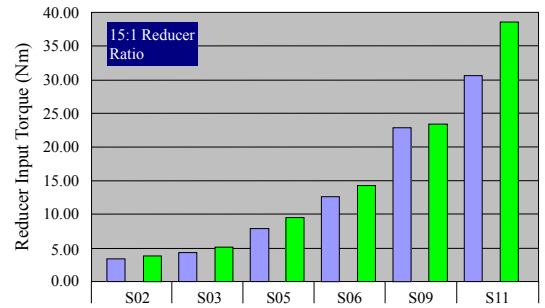
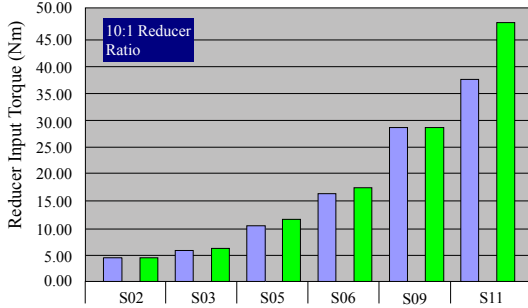
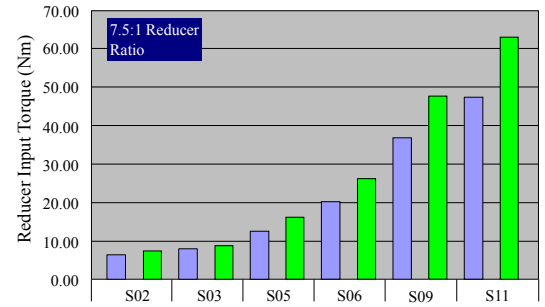

	Ratios		Size					
			S02	S03	S05	S06	S09	S11
Output Torque $T_{\text{accel}}^{(1)}$	5	lb. in.	333	491	927	1523	2805	4297
		Nm	37.6	55.5	104.8	172.1	316.9	485.5
	7.5	lb. in.	357	522	987	1615	2944	4480
		Nm	40.3	58.9	111.6	182.5	332.6	506.2
Motor Speed: 2000 RPM	10	lb. in.	295	455	882	1366	2294	4226
		Nm	33.3	51.4	99.7	154.3	259.2	477.4
	15	lb. in.	370	543	1058	1643	2761	5110
		Nm	41.8	61.4	119.5	185.7	311.9	577.3
	20	lb. in.	376	559	1091	1829	3418	5285
		Nm	42.5	63.1	123.2	206.6	386.2	597.1
	25	lb. in.	420	596	1172	1972	3331	5133
		Nm	47.5	67.4	132.4	222.8	376.4	580.0
	30 ⁽³⁾	lb. in.	396	576	1122	1880	3266	5435
		Nm	44.7	65.1	126.7	212.4	369.0	614.1
	40 ⁽³⁾	lb. in.	347	515	1005	1686	3152	4874
		Nm	39.2	58.2	113.6	190.5	356.1	550.7
	50 ⁽³⁾	lb. in.	339	501	964	1600	2962	4552
		Nm	38.3	56.6	108.9	180.8	334.7	514.3
	60 ⁽³⁾	lb. in.	314	465	903	1507	2807	4329
		Nm	35.5	52.6	102.0	170.3	317.2	489.1

		Size					
		S02	S03	S05	S06	S09	S11
Emergency Stop		(2 - Times T_{RUN})					
Maximum Radial Load ⁽²⁾ (2000 RPM motor speed)	lbs.	400	475	975	1100	1550	2200
	N	1780	2110	4330	4890	6890	9780
Weight Hollow Shaft Unit Oil Filled	lbs.	7	12	16	22	44	65
	kg	3.2	5.4	7.3	10	20	29.5
Operating Temperature	°F	(-13 to + 200)					
	°C	(-25 to + 93)					
Degree of Protection		IP 55					
Lubrication		Factory filled with 7s synthetic oil					
Mounting Position		any					

Key

- 1) These values are based on an input speed of 2000 rpm. For all input speeds and continuous run output torque ratings, see pages 18 - 23 for expanded rating tables.
- 2) Distance at the center of output keyway.
- 3) Ratios 30:1 and above can be self-locking. It is important to review the input torque applied during stopping and reversing. This is of particular importance when unrestrained high inertia loads are involved. Please contact our sales department to review your application.

	Ratios		Size					
			S02	S03	S05	S06	S09	S11
Moment of Inertia ⁽¹⁾ J_{gear}	5	lb. in. s ² 10 ⁻⁴	3.18	6.62	16.18	23.11	109.44	224.31
		kgcm ²	0.36	0.75	1.83	2.61	12.36	25.34
	7.5	lb. in. s ² 10 ⁻⁴	2.90	5.69	13.73	17.84	93.05	175.47
		kgcm ²	0.33	0.64	1.55	2.02	10.51	19.83
	10	lb. in. s ² 10 ⁻⁴	2.80	5.36	12.87	15.99	87.32	158.38
		kgcm ²	0.32	0.61	1.45	1.81	9.87	17.89
	15	lb. in. s ² 10 ⁻⁴	2.73	5.13	12.26	14.67	83.22	146.17
		kgcm ²	0.31	0.58	1.39	1.66	9.40	16.51
	20	lb. in. s ² 10 ⁻⁴	2.71	5.05	12.05	14.21	81.79	141.90
		kgcm ²	0.31	0.57	1.36	1.61	9.24	16.03
	25	lb. in. s ² 10 ⁻⁴	2.69	5.01	11.95	14.0	81.12	139.92
		kgcm ²	0.30	0.57	1.35	1.58	9.17	15.81
	30	lb. in. s ² 10 ⁻⁴	2.69	4.99	11.89	13.88	80.76	138.84
		kgcm ²	0.30	0.56	1.34	1.57	9.13	15.69
	40	lb. in. s ² 10 ⁻⁴	2.68	4.97	11.84	13.77	80.41	137.78
		kgcm ²	0.30	0.56	1.34	1.56	9.08	15.57
	50	lb. in. s ² 10 ⁻⁴	2.68	4.96	11.82	13.71	80.24	137.28
		kgcm ²	0.30	0.56	1.34	1.55	9.07	15.51
	60	lb. in. s ² 10 ⁻⁴	2.68	4.95	11.80	13.68	80.15	137.01
		kgcm ²	0.30	0.56	1.33	1.55	9.06	15.48

		Size					
		S02	S03	S05	S06	S09	S11
Nominal Backlash ⁽²⁾	arcmin.	41	30	23	20	15	12
Torsional Rigidity	lb. in./min	8.6	17	27	50	137	251
	Nm./min	1.0	1.9	3.1	5.6	15.5	28.4
Max. cyclic input speed ⁽³⁾	rpm	4000	4000	4000	4000	3000	3000
Max. continuous input speed ⁽⁴⁾	rpm	3000	3000	3000	3000	2000	2000

Key

- 1) The moment of inertia refers to the input shaft and includes coupling.
- 2) Please consider our Model RG or Series W products if lower backlash values are necessary. Please note these are nominal values and may vary.
- 3) Maximum input speed allowed for short acceleration cycles.
- 4) Maximum input speed allowed for duty cycles of 50% or greater.

Conversion Table

Metric	Inch
1 mm	0.0394 in.
1 N	0.225 lb
1 kg	2.205 lb.
1 Nm	8.85 in.lb.
1 kgcm ²	8.85 x 10 ⁻⁴ lb.in.s ²

Reducer Selection

$T_{1 \text{ acc motor}}$ is the maximum input torque experienced during acceleration or deceleration.

Step 2 assumes that the maximum output torque occurs during acceleration.

If there is a peak during operation that exceeds the acceleration output torque, that output torque value should be used here instead of the value calculated from $T_{1 \text{ acc motor}}$.

T_{accel} is based on the peak motor speed used in your application.

T_2 can be calculated as an average torque for continuous application. For complex torque profiles a weighted average, such as a root mean cubed, should be used (see equation 2 for example).

T_{run} based on average running speed in your application.

Step 7 is for reducers that are shaded in the ratings table only. These reducers have a thermal capacity that is lower than the mechanical limit of the reducer.

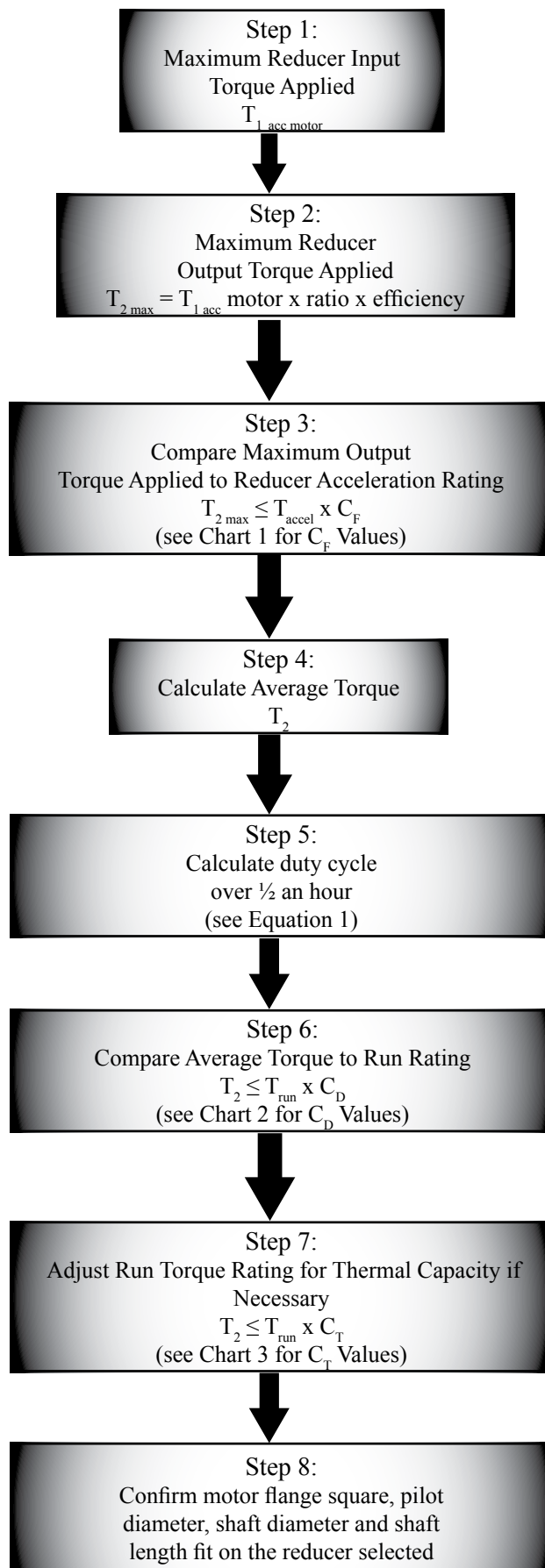

Reducer Selection

Chart 1 : Cycle Factor, C_F

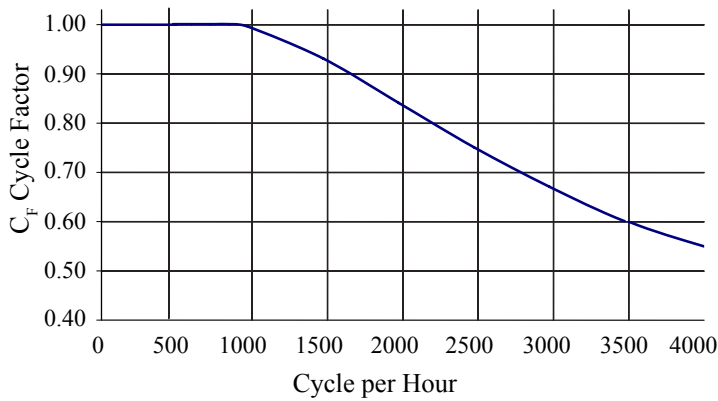

Chart 2 : Time Factor, C_D

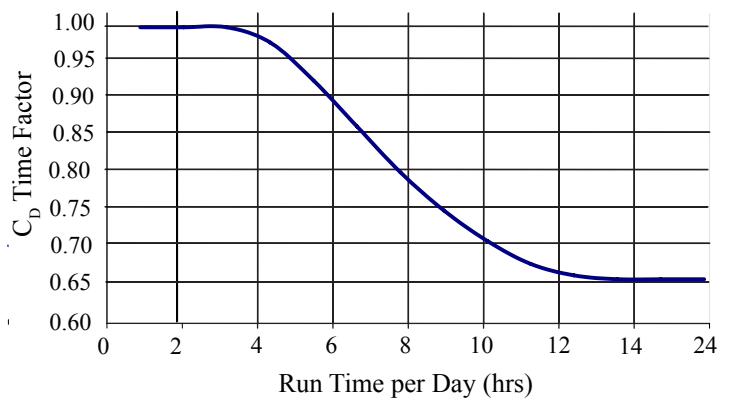
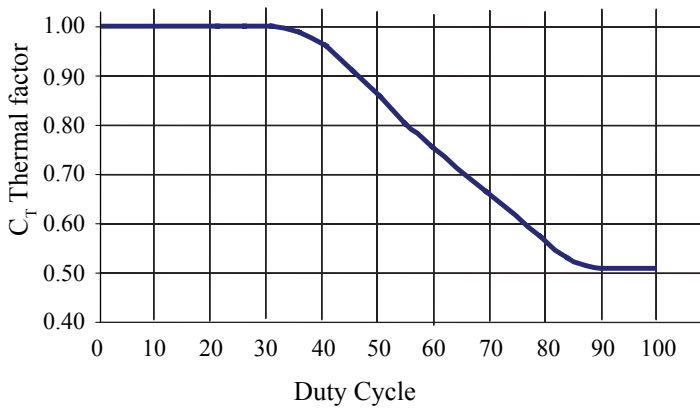
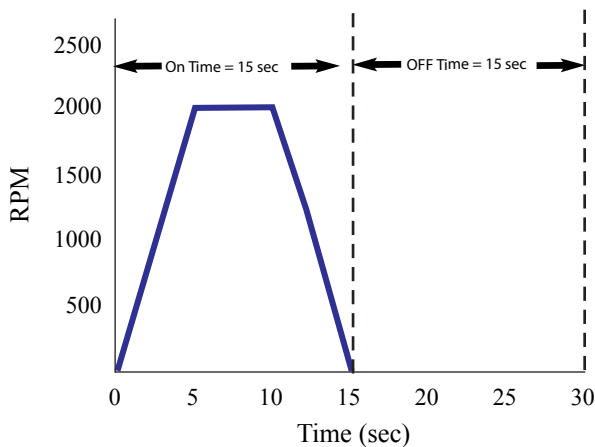

Chart 3 : Thermal Factor, C_T



Example



$$\text{Duty cycle \%} = (15)/(15 + 15) \times 100 = 50\%$$

$$T_{1 \text{ acc motor}} = 450 \text{ lb.in.}$$

$$T_2 = (300 \times 2.5 + 250 \times 2.5) / (2.5 + 2.5)$$

Equation 1

$$\text{Duty Cycle} = \frac{\text{On Time}}{\text{On Time} + \text{Off Time}} \times 100$$

Where n = speed,
t = time and
T = torque for each cycle segment

Equation 2

$$T_2 = \sqrt[3]{\frac{(n_1 \cdot t_1 \cdot T_1^3 + \dots + n_n \cdot t_n \cdot T_n^3)}{n_1 \cdot t_1 + \dots + n_n \cdot t_n}}$$

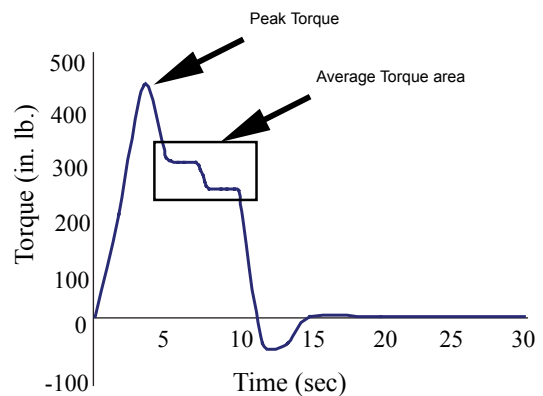

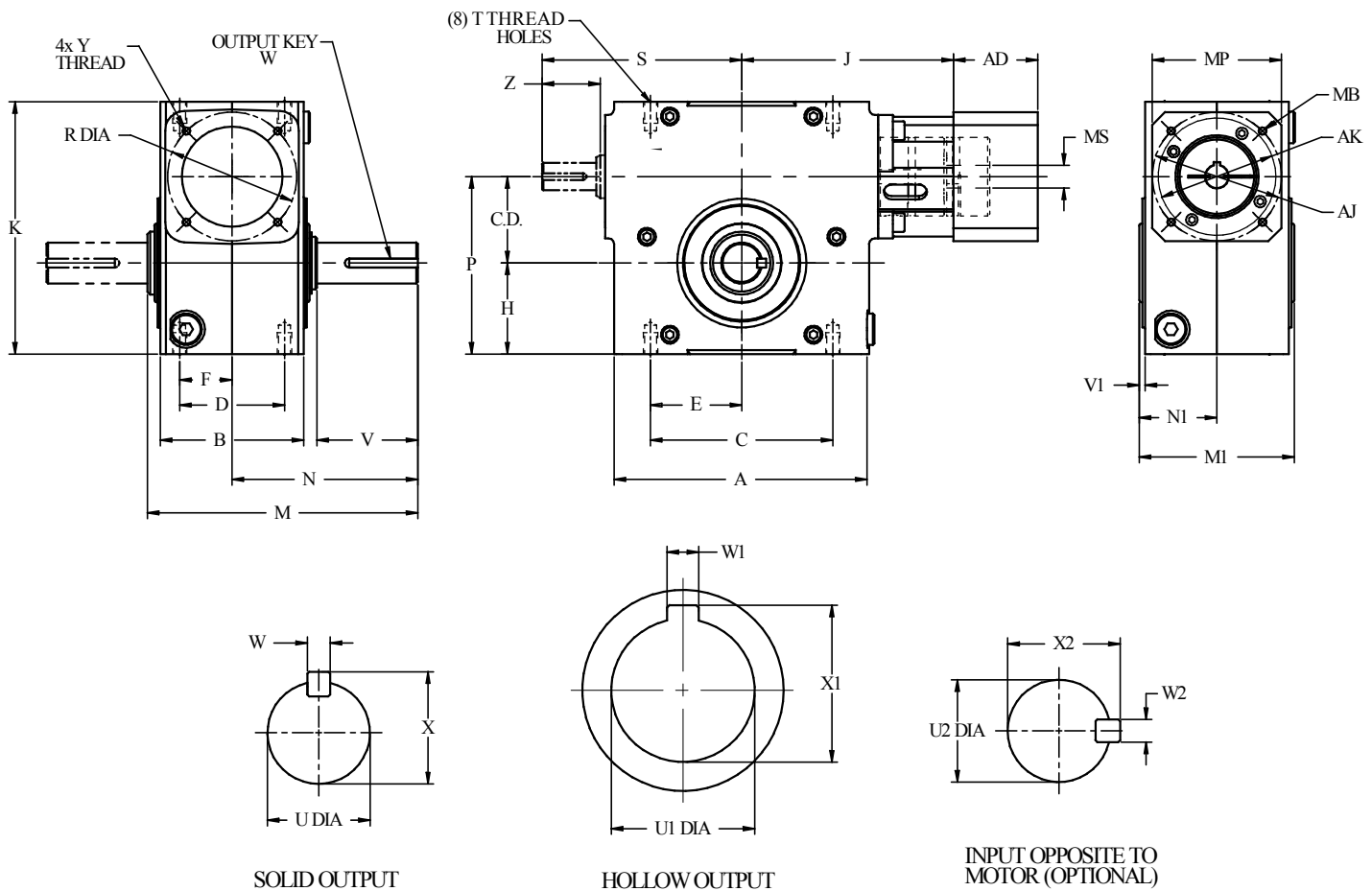

Case Size	C.D.	A	B	C	D	E	F	H	J
S02	1.33	4.33	2.76	3.25	2.00	1.63	1.00	1.72	4.95
S03	1.54	5.23	3.94	4.19	2.75	2.10	1.38	1.91	4.94
S05	1.97	6.00	3.94	5.00	2.88	2.50	1.44	2.28	5.37
S06	2.38	7.00	3.94	5.00	2.88	2.50	1.44	2.50	5.80
S09	3.00	9.00	5.12	7.00	4.00	3.50	2.00	3.25	7.25
S11	3.54	9.50	5.12	7.50	4.00	3.75	2.00	3.39	7.76

Case Size	K	M	M1	N	N1	P	R	S	T Thread
S02	4.66	6.10	3.85	4.00	1.93	3.05	2.51	4.22	M8
S03	5.35	6.61	4.25	4.31	2.12	3.45	3.56	4.93	M8
S05	6.38	7.00	4.21	4.69	2.11	4.25	3.56	5.20	M10
S06	6.93	7.41	4.25	5.09	2.13	4.88	3.56	5.47	M10
S09	8.88	9.70	5.43	6.75	2.72	6.25	5.01	7.63	M12
S11	9.84	11.34	6.65	7.75	3.33	6.93	5.01	8.35	M16

Case Size	SOLID OUTPUT				HOLLOW OUTPUT SHAFT					
	V	W	Y	Z	U (±.0005)	X	U1 (±.0005)	V1	W1	X1
S02	1.88	3/16 SQ x 1.00	M8	1.31	0.7495	0.828	1.0005	0.12	0.251	1.088
S03	1.99	3/16 SQ x 1.13	M8	1.48	0.7495	0.828	1.0005	0.08	0.251	1.088
S05	2.39	1/4 SQ x 1.50	M8	1.48	1.1245	1.232	1.4380	0.08	0.376	1.550
S06	2.77	1/4 SQ x 1.88	M8	1.48	1.1245	1.232	1.4380	0.08	0.376	1.550
S09	3.80	3/8 SQ x 2.00	M8	2.69	1.4995	1.658	2.1880	0.08	0.501	2.359
S11	4.15	1/2 SQ x 2.63	M8	2.95	1.8745	2.087	2.9380	0.10	0.751	3.151

Case Size	OPTIONAL INPUT SHAFT			SERVO MOTOR DIMENSIONS						WT (LBS)
	U2 (±.0005)	W2	X2	AD	AJ	AK	MB	MP	MS	
S02	0.6245	3/16 SQ x 1.0	0.703	MOTOR PLATE DIMENSIONS ARE MADE TO FIT YOUR SERVO MOTOR. REFER TO PAGE 7 & 8 FOR AVAILABLE DIMENSIONS						9
S03	0.7495	3/16 SQ x 1.13	0.828							14
S05	0.7495	3/16 SQ x 1.13	0.828							19
S06	0.7495	3/16 SQ x 1.13	0.828							25
S09	1.1870	1/4 SQ x 2.25	1.296							52
S11	1.1870	1/4 SQ x 2.63	1.296							82

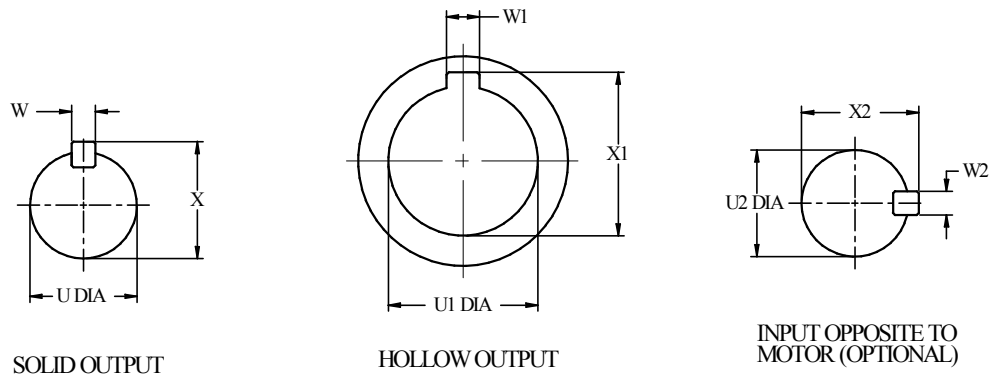
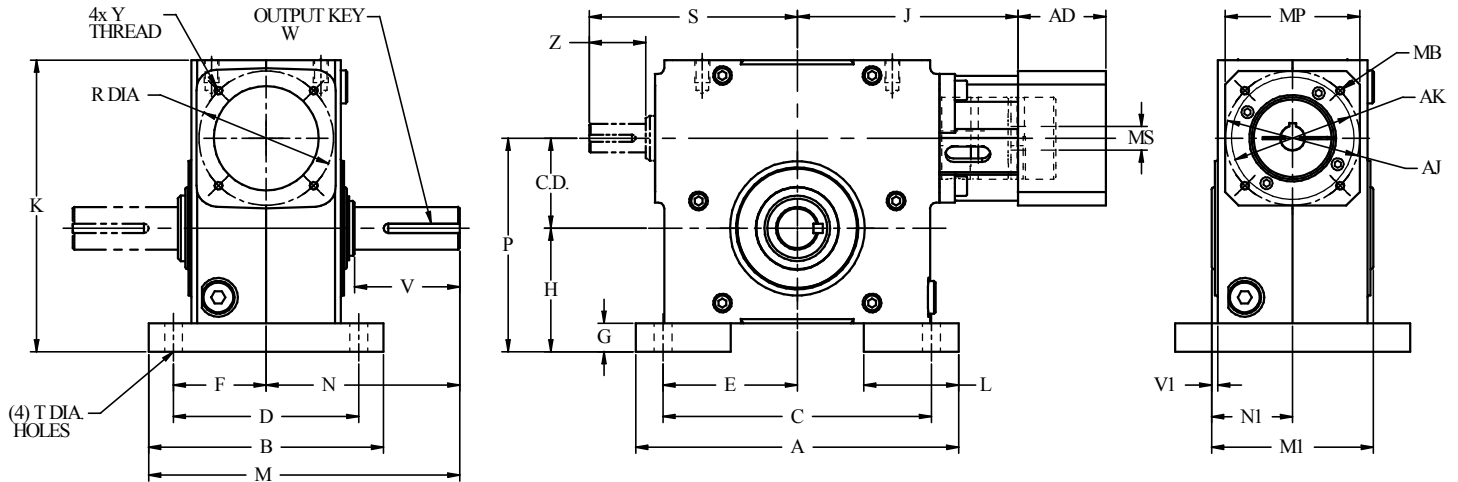

Case Size	C.D.	A	B	C	D	E	F	G	H	J
S02	1.33	5.38	4.19	4.38	3.31	2.19	1.66	0.53	2.25	4.95
S03	1.54	6.44	5.44	5.25	4.31	2.63	2.16	0.59	2.50	4.94
S05	1.97	7.75	5.94	6.38	4.69	3.19	2.35	0.72	3.00	5.37
S06	2.38	8.50	6.19	7.06	4.88	3.53	2.44	0.75	3.25	5.80
S09	3.00	10.00	7.50	8.44	5.88	4.22	2.94	0.75	4.00	7.25
S11	3.54	11.08	7.71	9.50	6.12	4.75	3.06	1.61	5.00	7.76

Case Size	K	L	M	M1	N	N1	P	R	S	T Dia.
S02	5.19	1.50	6.10	3.85	4.00	1.93	3.58	2.51	4.22	M8
S03	5.94	1.50	7.03	4.25	4.31	2.12	4.04	3.56	4.93	M8
S05	7.10	2.00	7.66	4.21	4.69	2.11	4.97	3.56	5.20	M10
S06	7.68	2.50	8.18	4.25	5.09	2.13	5.63	3.56	5.47	M10
S09	9.63	2.00	10.50	5.43	6.75	2.72	7.00	5.01	7.63	M12
S11	11.45	2.50	11.61	6.65	7.75	3.33	8.54	5.01	8.35	M16

Case Size	SOLID OUTPUT			HOLLOW OUTPUT SHAFT						
	V	W	Y	Z	U (±.0005)	X	U1 (±.0005)	V1	W1	X1
S02	1.88	3/16 SQ x 1.00	M8	1.31	0.7495	0.828	1.0005	0.12	0.251	1.088
S03	1.99	3/16 SQ x 1.13	M8	1.48	0.7495	0.828	1.0005	0.08	0.251	1.088
S05	2.39	1/4 SQ x 1.50	M8	1.48	1.1245	1.232	1.4380	0.08	0.376	1.550
S06	2.77	1/4 SQ x 1.88	M8	1.48	1.1245	1.232	1.4380	0.08	0.376	1.550
S09	3.80	3/8 SQ x 2.00	M8	2.69	1.4995	1.658	2.1880	0.08	0.501	2.359
S11	4.15	1/2 SQ x 2.63	M8	2.95	1.8745	2.087	2.9380	0.10	0.751	3.151

Case Size	OPTIONAL INPUT SHAFT			SERVO MOTOR DIMENSIONS						WT (LBS)
	U2 (±.0005)	W2	X2	AD	AJ	AK	MB	MP	MS	
S02	0.6245	3/16 SQ x 1.0	0.703	MOTOR PLATE DIMENSIONS ARE MADE TO FIT YOUR SERVO MOTOR. REFER TO PAGE 7 & 8 FOR AVAILABLE DIMENSIONS.						10
S03	0.7495	3/16 SQ x 1.13	0.828							15
S05	0.7495	3/16 SQ x 1.13	0.828							20
S06	0.7495	3/16 SQ x 1.13	0.828							27
S09	1.1870	1/4 SQ x 2.25	1.296							54
S11	1.1870	1/4 SQ x 2.63	1.296							88

Size S02

Servo Gearhead Expanded Rating Table

Ratio		Worm Shaft Speed. RPM									
		500		1000		2000		3000		4000	
		lb. in.	Nm	lb. in.	Nm	lb. in.	Nm	lb. in.	Nm	lb. in.	Nm
5:1	Output Torque T_{accel}	444	50.2	415	46.9	333	37.6	288	32.6	259	29.3
	Output Torque T_{run}	416	47.0	334	37.7	259	29.3	219	24.7	193	21.8
	Efficiency %	88		89		87		85		83	
7.5	Output Torque T_{accel}	527	59.5	438	49.5	357	40.3	312	35.3	281	31.7
	Output Torque T_{run}	439	49.6	358	40.4	283	32.0	243	27.4	215	24.2
	Efficiency %	80		82		86		85		84	
10:1	Output Torque T_{accel}	309	35.0	309	35.0	295	33.3	317	35.8	293	33.1
	Output Torque T_{run}	309	35.0	309	35.0	294	33.3	254	28.7	228	25.7
	Efficiency %	83		84		82		80		78	
15:1	Output Torque T_{accel}	368	41.6	368	41.6	370	41.8	347	39.2	310	35.0
	Output Torque T_{run}	368	41.6	368	41.6	312	35.2	272	30.8	245	27.7
	Efficiency %	78		79		77		75		73	
20:1	Output Torque T_{accel}	532	60.1	451	50.9	376	42.5	335	37.9	305	34.5
	Output Torque T_{run}	452	51.1	377	42.5	309	34.9	271	30.6	244	27.6
	Efficiency %	72		74		72		70		67	
25:1	Output Torque T_{accel}	463	52.3	441	49.8	420	47.5	376	42.5	326	36.9
	Output Torque T_{run}	463	52.3	442	47.6	347	39.2	306	34.6	263	29.7
	Efficiency %	68		70		68		66		63	
30:1	Output Torque T_{accel}	428	48.4	432	48.8	396	44.7	347	39.3	318	35.9
	Output Torque T_{run}	428	48.4	392	44.3	321	36.3	284	32.1	258	29.2
	Efficiency %	65		66		65		62		59	
40:1	Output Torque T_{accel}	479	54.1	410	46.3	347	39.2	312	35.2	286	32.3
	Output Torque T_{run}	411	46.4	348	39.3	289	32.6	257	29.0	234	26.4
	Efficiency %	57		58		56		53		50	
50:1	Output Torque T_{accel}	465	52.6	400	45.2	339	38.3	306	34.5	282	31.8
	Output Torque T_{run}	401	45.3	340	38.4	284	32.1	253	28.6	232	26.2
	Efficiency %	51		52		50		47		44	
60:1	Output Torque T_{accel}	392	44.3	369	41.7	314	35.5	284	32.0	261	29.5
	Output Torque T_{run}	370	41.8	315	35.6	264	29.8	236	26.6	216	24.4
	Efficiency %	45		46		44		41		38	

Applications where the duty cycle is 50% or greater require the shaded area value to be corrected by the appropriate Thermal Factor, C_T . See chart on page 15.

Size S03

Servo Gearhead Expanded Rating Table

Ratio		Worm Shaft Speed. RPM									
		500		1000		2000		3000		4000	
		lb. in.	Nm	lb. in.	Nm	lb. in.	Nm	lb. in.	Nm	lb. in.	Nm
5:1	Output Torque T_{accel}	681	77.0	612	69.2	491	55.5	425	48.1	381	43.0
	Output Torque T_{run}	612	69.2	491	55.5	381	43.0	322	36.3	282	31.8
	Efficiency %	89		89		88		86		85	
7.5	Output Torque T_{accel}	772	87.2	641	72.5	522	58.9	456	51.6	412	46.6
	Output Torque T_{run}	641	72.5	522	58.9	412	46.6	353	39.9	313	35.4
	Efficiency %	86		87		86		84		82	
10:1	Output Torque T_{accel}	455	51.4	455	51.4	455	51.4	454	51.3	427	48.2
	Output Torque T_{run}	455	51.4	455	51.4	427	48.2	369	41.7	330	37.3
	Efficiency %	84		85		84		82		80	
15:1	Output Torque T_{accel}	543	61.4	543	61.4	543	61.4	503	56.8	459	51.9
	Output Torque T_{run}	543	61.4	543	61.4	459	51.9	401	45.3	362	40.9
	Efficiency %	79		81		80		78		76	
20:1	Output Torque T_{accel}	791	89.3	670	75.7	559	63.1	498	56.3	457	51.6
	Output Torque T_{run}	670	75.7	559	63.1	457	51.6	401	45.3	364	41.1
	Efficiency %	74		76		75		73		71	
25:1	Output Torque T_{accel}	687	77.6	687	77.6	596	67.4	533	60.2	490	55.4
	Output Torque T_{run}	687	77.6	596	67.4	490	55.4	432	48.8	393	44.4
	Efficiency %	70		72		71		69		67	
30:1	Output Torque T_{accel}	633	71.6	633	71.6	576	65.1	516	58.3	476	53.7
	Output Torque T_{run}	633	71.6	576	65.1	476	53.7	421	47.5	384	43.4
	Efficiency %	67		69		68		66		63	
40:1	Output Torque T_{accel}	712	80.4	610	68.9	515	58.2	463	52.3	428	48.3
	Output Torque T_{run}	610	68.9	515	58.2	428	48.3	380	42.9	348	39.3
	Efficiency %	59		61		60		57		55	
50:1	Output Torque T_{accel}	688	77.8	591	66.8	501	56.6	452	51.0	418	47.2
	Output Torque T_{run}	591	66.8	501	56.6	418	47.2	373	42.1	342	38.6
	Efficiency %	53		55		54		51		49	
60:1	Output Torque T_{accel}	588	66.4	548	61.9	465	52.6	420	47.5	389	44.0
	Output Torque T_{run}	548	61.9	465	52.6	389	44.0	348	39.3	320	36.1
	Efficiency %	48		50		48		46		43	

Applications where the duty cycle is 50% or greater require the shaded area value to be corrected by the appropriate Thermal Factor, C_T . See chart on page 15.

Size S05

Servo Gearhead Expanded Rating Table

Ratio		Worm Shaft Speed. RPM									
		500		1000		2000		3000		4000	
		lb. in.	Nm	lb. in.	Nm	lb. in.	Nm	lb. in.	Nm	lb. in.	Nm
5:1	Output Torque T_{accel}	1342	151.6	1158	130.8	927	104.8	802	90.7	718	81.1
	Output Torque T_{run}	1158	130.8	927	104.8	718	81.1	605	68.4	530	59.9
	Efficiency %	91		91		91		90		88	
7.5	Output Torque T_{accel}	1464	165.4	1216	137.4	987	111.6	863	97.5	779	88.0
	Output Torque T_{run}	1216	137.4	987	111.6	779	88.0	667	75.4	591	66.8
	Efficiency %	88		89		89		88		87	
10:1	Output Torque T_{accel}	882	99.7	882	99.7	882	99.7	873	98.7	793	89.5
	Output Torque T_{run}	882	99.7	882	99.7	793	89.5	684	77.3	612	69.1
	Efficiency %	86		88		87		86		85	
15:1	Output Torque T_{accel}	1058	119.5	1058	119.5	1058	119.5	965	109.0	881	99.5
	Output Torque T_{run}	1058	119.5	1058	119.5	881	99.5	768	86.8	693	78.2
	Efficiency %	82		84		84		83		82	
20:1	Output Torque T_{accel}	1546	174.7	1310	148.0	1091	123.2	971	109.7	890	100.6
	Output Torque T_{run}	1310	148.0	1091	123.2	890	100.6	781	88.2	707	79.9
	Efficiency %	78		80		80		79		78	
25:1	Output Torque T_{accel}	1315	148.6	1315	148.6	1172	132.4	1047	118.2	962	108.6
	Output Torque T_{run}	1315	148.6	1172	132.4	962	108.6	847	95.7	770	87.0
	Efficiency %	74		76		77		76		75	
30:1	Output Torque T_{accel}	1236	139.6	1236	139.6	1122	126.7	1004	113.5	925	104.5
	Output Torque T_{run}	1236	139.6	1122	126.7	925	104.5	818	92.4	745	84.2
	Efficiency %	71		74		74		73		72	
40:1	Output Torque T_{accel}	1393	157.3	1191	134.6	1005	113.6	903	102.0	834	94.2
	Output Torque T_{run}	1191	134.6	1005	113.6	834	94.2	740	83.6	677	76.5
	Efficiency %	64		67		67		66		65	
50:1	Output Torque T_{accel}	1327	149.9	1138	128.6	964	108.9	868	98.0	803	90.7
	Output Torque T_{run}	1138	128.6	964	108.9	803	90.7	715	80.8	655	74.0
	Efficiency %	58		61		62		60		59	
60:1	Output Torque T_{accel}	1237	139.7	1063	120.1	903	102.0	814	92.0	754	85.2
	Output Torque T_{run}	1063	120.1	903	102.0	754	85.2	673	76.1	618	69.9
	Efficiency %	53		56		56		55		54	

Applications where the duty cycle is 50% or greater require the shaded area value to be corrected by the appropriate Thermal Factor, C_T . See chart on page 15.

Size S06

Servo Gearhead Expanded Rating Table

Ratio		Worm Shaft Speed. RPM									
		500		1000		2000		3000		4000	
		lb. in.	Nm	lb. in.	Nm	lb. in.	Nm	lb. in.	Nm	lb. in.	Nm
5:1	Output Torque T_{accel}	2312	261.2	1904	215.1	1523	172.1	1317	148.8	1178	133.1
	Output Torque T_{run}	1904	215.1	1523	172.1	1178	133.1	992	112.1	868	98.1
	Efficiency %	92		92		92		91		90	
7.5	Output Torque T_{accel}	2400	271.2	1991	224.9	1615	182.5	1411	159.4	1273	143.9
	Output Torque T_{run}	1991	224.9	1615	182.5	1273	143.9	1089	123.0	965	109.0
	Efficiency %	90		91		91		90		89	
10:1	Output Torque T_{accel}	1366	154.3	1366	154.3	1366	154.3	1368	154.6	1282	144.8
	Output Torque T_{run}	1366	154.3	1366	154.3	1282	144.8	1106	125.0	988	111.6
	Efficiency %	88		89		89		89		88	
15:1	Output Torque T_{accel}	1643	185.7	1643	185.7	1643	185.7	1600	180.7	1460	165.0
	Output Torque T_{run}	1643	185.7	1643	185.7	1460	165.0	1273	143.8	1147	129.6
	Efficiency %	84		86		87		86		85	
20:1	Output Torque T_{accel}	2598	293.5	2198	248.3	1829	206.6	1627	183.9	1491	168.4
	Output Torque T_{run}	2198	248.3	1829	206.6	1491	168.4	1307	147.7	1183	133.7
	Efficiency %	80		82		83		83		82	
25:1	Output Torque T_{accel}	2074	234.4	2074	234.4	1972	222.8	1760	198.8	1616	182.6
	Output Torque T_{run}	2074	234.4	1972	222.8	1616	182.6	1423	160.8	1292	146.0
	Efficiency %	76		79		80		80		80	
30:1	Output Torque T_{accel}	1923	217.3	1923	217.3	1880	212.4	1682	190.1	1548	174.9
	Output Torque T_{run}	1923	217.3	1880	212.4	1548	174.9	1368	154.5	1246	140.7
	Efficiency %	73		77		78		78		77	
40:1	Output Torque T_{accel}	2340	264.4	2000	226.0	1686	190.5	1514	171.0	1397	157.8
	Output Torque T_{run}	2000	226.0	1686	190.5	1397	157.8	1239	140.0	1133	128.0
	Efficiency %	67		70		72		71		70	
50:1	Output Torque T_{accel}	2207	249.4	1892	213.8	1600	180.8	1440	162.7	1331	150.4
	Output Torque T_{run}	1892	213.8	1600	180.8	1331	150.4	1185	133.9	1086	122.6
	Efficiency %	61		65		66		66		65	
60:1	Output Torque T_{accel}	2069	233.8	1778	200.9	1507	170.3	1359	153.6	1258	142.2
	Output Torque T_{run}	1778	200.9	1507	170.3	1258	142.2	1122	126.8	1030	116.4
	Efficiency %	56		60		62		61		60	

Applications where the duty cycle is 50% or greater require the shaded area value to be corrected by the appropriate Thermal Factor, C_T . See chart on page 15.

Size S09

Servo Gearhead Expanded Rating Table

Ratio		Worm Shaft Speed. RPM							
		500		1000		2000		3000	
		lb. in.	Nm	lb. in.	Nm	lb. in.	Nm	lb. in.	Nm
5:1	Output Torque T_{accel}	4124	465.9	3511	396.7	2805	316.9	2423	273.8
	Output Torque T_{run}	3511	396.7	2805	316.9	2166	244.7	1823	205.9
	Efficiency %	92		93		93		93	
7.5	Output Torque T_{accel}	4385	495.5	3633	410.5	2944	332.6	2569	290.3
	Output Torque T_{run}	3633	410.5	2944	332.6	2317	261.8	1979	223.6
	Efficiency %	91		92		92		92	
10:1	Output Torque T_{accel}	2288	258.5	2288	258.5	2294	259.2	2293	259.1
	Output Torque T_{run}	2288	258.5	2288	258.5	2294	259.2	1989	224.7
	Efficiency %	89		91		91		91	
15:1	Output Torque T_{accel}	2761	311.9	2761	311.9	2761	311.9	2770	312.9
	Output Torque T_{run}	2761	311.9	2761	311.9	2698	304.9	2350	265.5
	Efficiency %	86		88		89		89	
20:1	Output Torque T_{accel}	4868	550.0	4114	464.8	3418	386.2	3039	343.3
	Output Torque T_{run}	4114	464.8	3418	386.2	2782	314.3	2437	275.3
	Efficiency %	82		84		86		86	
25:1	Output Torque T_{accel}	4708	531.9	3992	451.0	3331	376.4	2971	335.6
	Output Torque T_{run}	3992	451.0	3331	376.4	2726	308.0	2398	270.9
	Efficiency %	78		81		83		83	
30:1	Output Torque T_{accel}	3266	369.0	3266	369.0	3266	369.0	3142	355.0
	Output Torque T_{run}	3266	369.0	3266	369.0	2889	326.5	2550	288.1
	Efficiency %	76		79		81		81	
40:1	Output Torque T_{accel}	4385	495.4	3744	423.0	3152	356.1	2827	319.4
	Output Torque T_{run}	3744	423.0	3152	356.1	2607	294.6	2311	261.1
	Efficiency %	70		74		76		76	
50:1	Output Torque T_{accel}	4096	462.8	3507	396.2	2962	334.7	2663	300.9
	Output Torque T_{run}	3507	396.2	2962	334.7	2461	278.0	2188	247.2
	Efficiency %	64		68		71		71	
60:1	Output Torque T_{accel}	3863	436.5	3315	374.6	2807	317.2	2529	285.7
	Output Torque T_{run}	3315	374.6	2807	317.2	2340	264.3	2085	235.6
	Efficiency %	60		64		66		67	

Applications where the duty cycle is 50% or greater require the shaded area value to be corrected by the appropriate Thermal Factor, C_T . See chart on page 15.

Size S11

Servo Gearhead Expanded Rating Table

Ratio		Worm Shaft Speed. RPM							
		500		1000		2000		3000	
		lb. in.	Nm	lb. in.	Nm	lb. in.	Nm	lb. in.	Nm
5:1	Output Torque T_{accel}	6574	742.7	5384	608.3	4297	485.5	3709	419.1
	Output Torque T_{run}	5384	608.3	4297	485.5	3314	374.4	2786	314.8
	Efficiency %	93		94		94		94	
7.5	Output Torque T_{accel}	6687	755.6	5535	625.4	4480	506.2	3908	441.5
	Output Torque T_{run}	5535	625.4	4480	506.2	3522	397.9	3006	339.7
	Efficiency %	91		93		93		93	
10:1	Output Torque T_{accel}	4226	477.4	4226	477.4	4226	477.4	3855	435.6
	Output Torque T_{run}	4226	477.4	4226	477.4	3494	394.7	3010	340.0
	Efficiency %	90		91		92		92	
15:1	Output Torque T_{accel}	5110	577.3	5110	577.3	5110	577.3	4550	514.1
	Output Torque T_{run}	5110	577.3	5110	577.3	4148	468.7	3610	407.9
	Efficiency %	87		89		90		90	
20:1	Output Torque T_{accel}	7540	851.9	6366	719.3	5285	597.1	4695	530.5
	Output Torque T_{run}	6366	719.3	5285	597.1	4296	485.4	3760	424.9
	Efficiency %	83		86		87		87	
25:1	Output Torque T_{accel}	7267	821.1	6157	695.7	5133	580.0	4574	516.8
	Output Torque T_{run}	6157	695.7	5133	580.0	4196	474.1	3688	416.6
	Efficiency %	80		83		84		85	
30:1	Output Torque T_{accel}	6009	678.9	6009	678.9	5435	614.1	4857	548.8
	Output Torque T_{run}	6009	678.9	5435	614.1	4465	504.5	3938	444.9
	Efficiency %	78		81		83		83	
40:1	Output Torque T_{accel}	6795	767.7	5797	654.9	4874	550.7	4370	493.7
	Output Torque T_{run}	5797	654.9	4874	550.7	4028	455.1	3567	403.0
	Efficiency %	72		75		78		78	
50:1	Output Torque T_{accel}	6306	712.5	5395	609.6	4552	514.3	4090	462.2
	Output Torque T_{run}	5395	609.6	4552	514.3	3777	426.8	3356	379.1
	Efficiency %	66		71		73		74	
60:1	Output Torque T_{accel}	5969	674.4	5118	578.2	4329	489.1	3897	440.3
	Output Torque T_{run}	5118	578.2	4329	489.1	3604	407.2	3209	362.6
	Efficiency %	62		66		69		70	

Applications where the duty cycle is 50% or greater require the shaded area value to be corrected by the appropriate Thermal Factor, C_T . See chart on page 15.

Installation and Operation

Lubrication

Series S Servo Gearheads are factory filled with Mobil SHC634 synthetic lubricant. They are sealed and require no lubrication service throughout the life of the unit. Series S Servo gearheads are built for universal mounting, ready to mount in any position.

Mounting Servo Motor on Gearhead:

1. Clean motor shaft and mating surfaces of the motor and gearhead to ensure they are dust-free.
2. Mount the coupling halves on gearhead shaft and servo motor half following the process described on next page.
3. The tightening torque for the coupling clamping screws is as follows:
 - a. S02 thru S09: 90 lb.in. (10 Nm)
 - b. S11: 220 lb.in. (25 Nm)

Securing Reducer to Machine Base

1. The machine base must be flat within .002” (0.05 mm) over the entire area in contact with the reducer.
2. When bolting the reducer to machine base, tighten foundation bolts to housing observing these torque values:

Reducer size	Bolt Size	Torque lb. - ft.	Torque Nm
S02 (34 mm)	M8	18 - 22	24 - 30
S03 (39 mm)	M8	18 - 22	24 - 30
S05 (50 mm)	M10	37 - 44	50 - 60
S06 (60 mm)	M10	37 - 44	50 - 60
S09 (76 mm)	M12	65 - 77	88 - 105
S11 (90 mm)	M16	161 - 192	218 - 261

3. If a solid output is used, the output shaft of the gearhead should be coupled to the driven shaft with a flexible coupling and the gearhead aligned with the shaft within +/- .001.” Solid or rigid couplings should be avoided. Failure to properly align shafts and the use of solid couplings can result in excessive coupling and bearing wear, shaft deflection and eventual failure of one or more of the components.

Ancillary Components

1. When mounting couplings, pulleys or gears directly to the gearhead, refrain from hammering

the component onto the shaft. If pressing the component onto the shaft, adequately support the gearhead’s shaft in such a manner that prevents the gearhead bearings from supporting the press force, as the force to press on components may fail the bearings or individual components.

2. Sprockets, gears and sheaves should be mounted as close to the gearhead as possible. Belts and chains must be adjusted to the proper tension to keep bearing loading and shaft deflection to a minimum. Too much tension and improper location will lead to excessive overhung load, bearing wear and shaft deflection. For specific information on overhung load capacity, shaft stress and bearing life, please contact Cone Drive.

Start-Up

1. All gearheads require a “run-in” period under load to achieve optimum efficiency. During this initial run-in the gearhead will probably run warmer than normal and draw more current than after the run-in period. Gearheads operating at a very low load or speed will take much longer to run-in.
2. **IMPORTANT:** Normal gearhead operating temperature measured at the oil sump area of the housing should not exceed 200° F (93° C) maximum. If the gearhead operating temperature exceeds these limits, shut down the unit and contact Cone Drive. Excessive oil sump temperature may be indicative of overloading, misalignment, or improper lubrication. Continuous operation of the gearhead with the oil sump temperature above 250° F (120° C) for the synthetic lubricant, will result in failure of the gearhead.

Maintenance

1. Series S gearheads require no periodic maintenance. They are not user-serviceable or repairable.
2. If a gearhead is to be returned, contact Cone Drive for instructions and a Return Material Authorization (RMA) number.
3. Please have model number information from the unit nameplate recorded.

Call Parts & Service Toll Free 888-726-2663

Assembly of Coupling to Reducer and Gearhead

The coupling's three piece design allows the hubs to be installed on each individual shaft and then joined axially.

Procedure:

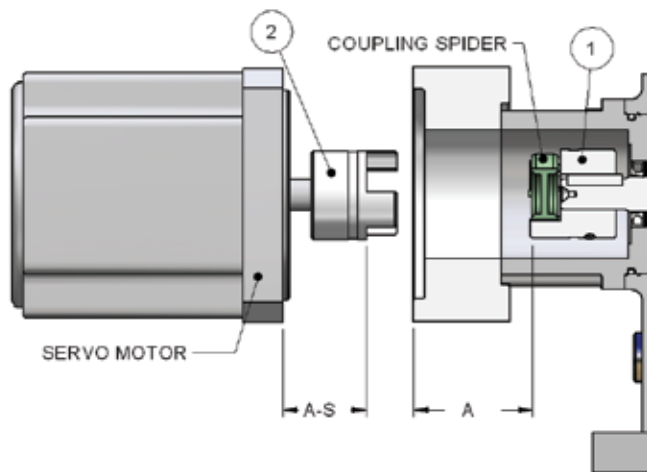

1. The coupling hub #1 will be installed on the gearhead from the factory.
2. Measure "A" dimension from end of coupling to mating face of flange.
3. Subtract "S" (see table below) from "A".
4. Locate coupling hub #2 on motor shaft so that the inside face of the coupling is located "A-S" from the mating motor face, as shown.
5. Tighten the clamp screw to the torque specified below.
6. Measure dimension "R" on the motor shaft. This is the distance that the shaft does not extend through the full-length of the coupling bore. If R is greater than the value shown in table below, reposition the coupling hub #1 on the gearhead outward about half the measured distance. Be sure to tighten the coupling clamp screw to the proper torque.
7. Repeat steps 2 through 5.
8. After positioning, dimension "R" shouldn't exceed the value in the table for either coupling half.
9. Lightly oil the coupling spider and position it on coupling hub #1.
10. Assemble the motor to the gearhead. If required, rotate the shafts through the access slots to aid in alignment.

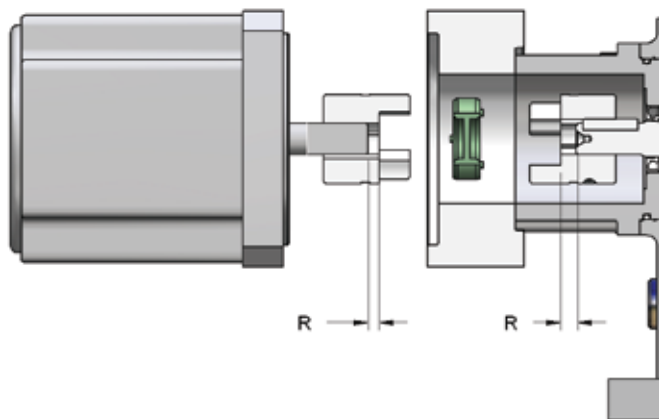

Unit Size	Dimension "S"	Dimension "R"	Coupling Clamp Screw Torque
S02, S03, S05	0.08" (2 mm)	0.31" (8 mm)	93 in lb (10 Nm)
S06, S09	0.08" (2 mm)	0.57" (14.5 mm)	93 in lb (10 Nm)
S11	0.10" (2.5 mm)	0.73" (18.5 mm)	220 in lb (25 Nm)

Call Parts & Service Toll Free 888-726-2663

Notes

Notes



Cone Drive Family of Products



Model HP



AccuDrive



Gearsets



Specials



Cone Drive Operations, Inc
240 E. 12th Street,
Traverse City, MI. 49685

Sales: 1-888-994-2663
Sales Fax: 1-888-907-2663