

**Technical
Up to - 2,500 Hp / 122,000 Lb-ft**

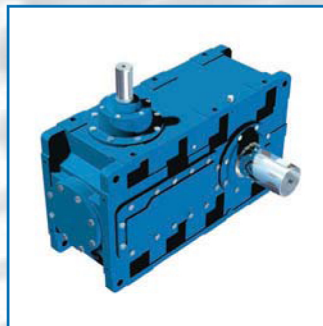

INDUSTRIAL GEARBOX

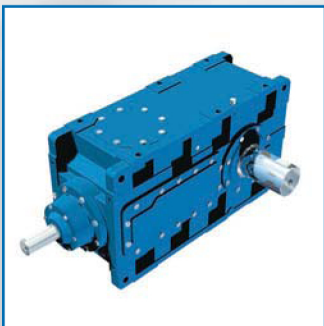

PRODUCTS IN THE RANGE

Serving an entire spectrum of mechanical drive applications from food, energy, mining and metal; to automotive, aerospace and marine propulsion, we are here to make a positive difference to the supply of drive solutions.

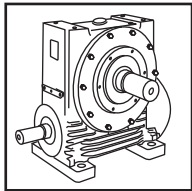

Series A
Worm Gear units and geared motors in single & double reduction types

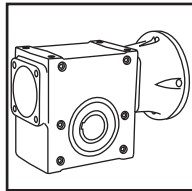

Series B
Conax helical gear geometry right angle gearmotors and reducers

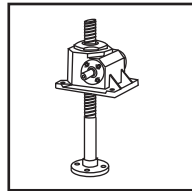

Series BD
Screwjack worm gear unit

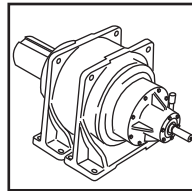

HTP
High torque planetary gear units

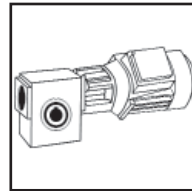

Series BS
Worm gear unit

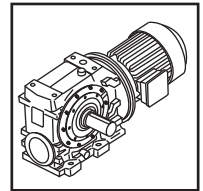

Series C
Right angle drive helical worm geared motors & reducers

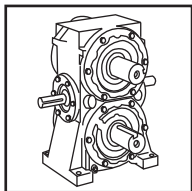

DuoDrive
Dual gears on parallel output shafts

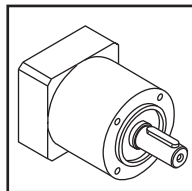

Series E
Economical planetary servo gearboxes

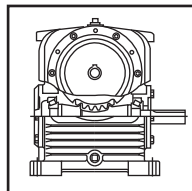

Extruder Drive
Rugged duty reducer takes high screw pressure

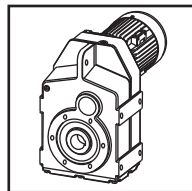

Series F
Parallel angle helical bevel helical geared motors & reducers

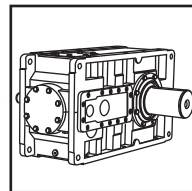

Series G
Helical parallel shaft & bevel helical right angle drive gear units

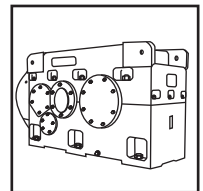

Series H
Large helical parallel shaft & bevel helical right angle drive units

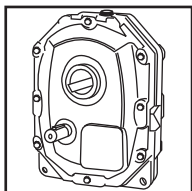

Series J
Shaft mounted helical speed reducers

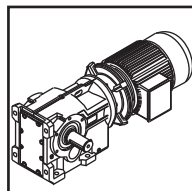

Series K
Right angle helical bevel helical geared motors & reducers

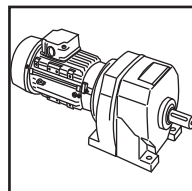

Series M
In-line helical geared motors & reducers

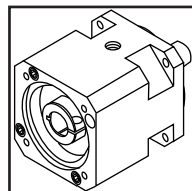

Series P
Precision planetary servo gearboxes

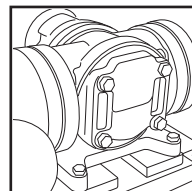

Roloid Gear Pump
Lubrication and fluid transportation pump

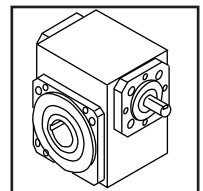

Series W
Precision right angle servo gearboxes

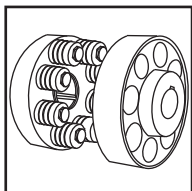

Series X Cone Ring
Pin and bush elastomer coupling

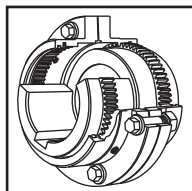

Series X Gear
Torsionally rigid, high torque coupling

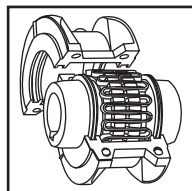

Series X Grid
Double flexing steel grid coupling

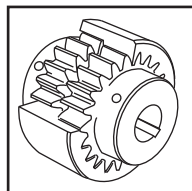

Series X Nylon
Gear coupling with nylon sleeve

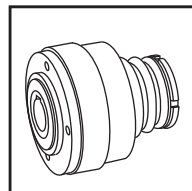

Series X Torque Limiter
Overload protection device



We offer a wide range of repair services and many years experience of repairing demanding and highly critical transmissions in numerous industries.

We can create custom engineered transmission solutions of any size and configuration.

General Description	1
Unit Designations	2
Design Features	3 - 4
Explanation and use of Ratings and Service Factors	5 - 7
Selection Procedure	8 - 9
Unit Handings and Shaft Rotations	10 -11
Installation & Maintenance	13 - 17
Fault Diagnosis	18
Lubrication	19 - 21
Standard Shaft Sealing Arrangements	22
Input Shaft Options	23
Output Shaft Options	24
Output Bore Options	25
REDUCER	
Overhung & Axial Loads on Shafts	28 - 29
Agitator Applications	30 - 31
Parallel Shaft Units	
Moments of Inertia	34
Exact Ratios	35
Mechanical Ratings - Input Power / Output Torque	36 - 39
Thermal Ratings	40
Dimension Sheets - Speed Reducers	41 - 44
Fan Cooling	45
Right Angle Shaft Units	
Moments of Inertia	48
Exact Ratios	49
Mechanical Ratings - Input Power / Output Torque	50 - 53
Thermal Ratings	54
Dimension Sheets - Speed Reducers	55 - 60
Fan Cooling	61
Hollow Output Shaft with Shrink Disc	62
Keyed Sleeves	63
Cooling Coil Connections	64
Backstops	65
Torque Arm	66
MOTORIZED	
Motorized Dimension	68 - 69
Shipping Specification	70

GENERAL DESCRIPTION

Series G

Series G gear units are available in parallel shaft helical units and right angle shaft bevel/helical units in double, triple and quadruple reduction gear stages.

The modular design and construction of the Series G offers many engineering and performance benefits including a high degree of interchangeability of parts and sub assemblies. This in turn provides considerable economies of production while maintaining the highest standard of component integrity.

Adding to the range of power transmission geared motors this product takes advantage of our many years of accumulated design expertise together with the use of high quality materials and components. The end result is a series of speed reducing gear units offering high load carrying capacities, increased efficiency, quiet running and reliability.

The Range Includes

- 8 sizes of units with a ratio coverage of 6.3:1 to 315:1.
- Parallel shaft helical units and Right angle bevel/helical units.

Design Features Include

- Profile ground helical gears / hard finished spiral bevel gears.
- High level of surface finish for quiet running.
- Units can be offered in horizontal mounting positions or alternatively vertical mounting.
- Specially designed units are available for heavy duty agitator applications.
- All units are also available with a hollow bore for output shaft mounting. Output bores are connected by a shrink disc or can be supplied with a keyed sleeve.
- Backstops can be fitted to all Series G units when required to operate in non-reversing drives.

As improvements in design are being made continually this specification is not to be regarded as binding in detail and drawings and capacities are subject to alteration without notice. Certified drawings will be sent on request.

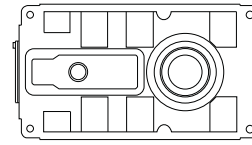

Parallel shaft unit

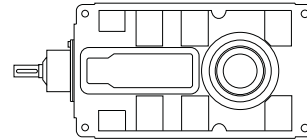

Right angle shaft unit

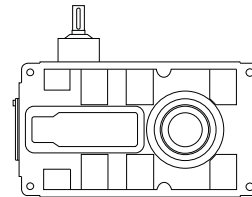

Type 'J' right angle shaft unit

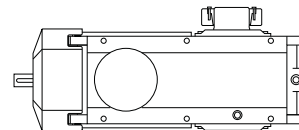

Right angle shaft unit with mechanical fan and hollow output shaft with shrink disc

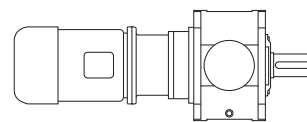

Parallel shaft unit with a lantern housing coupling and motor

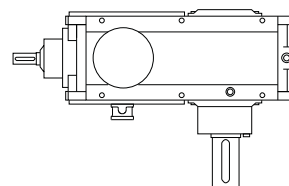

Right angle heavy duty agitator unit

UNIT DESIGNATIONS

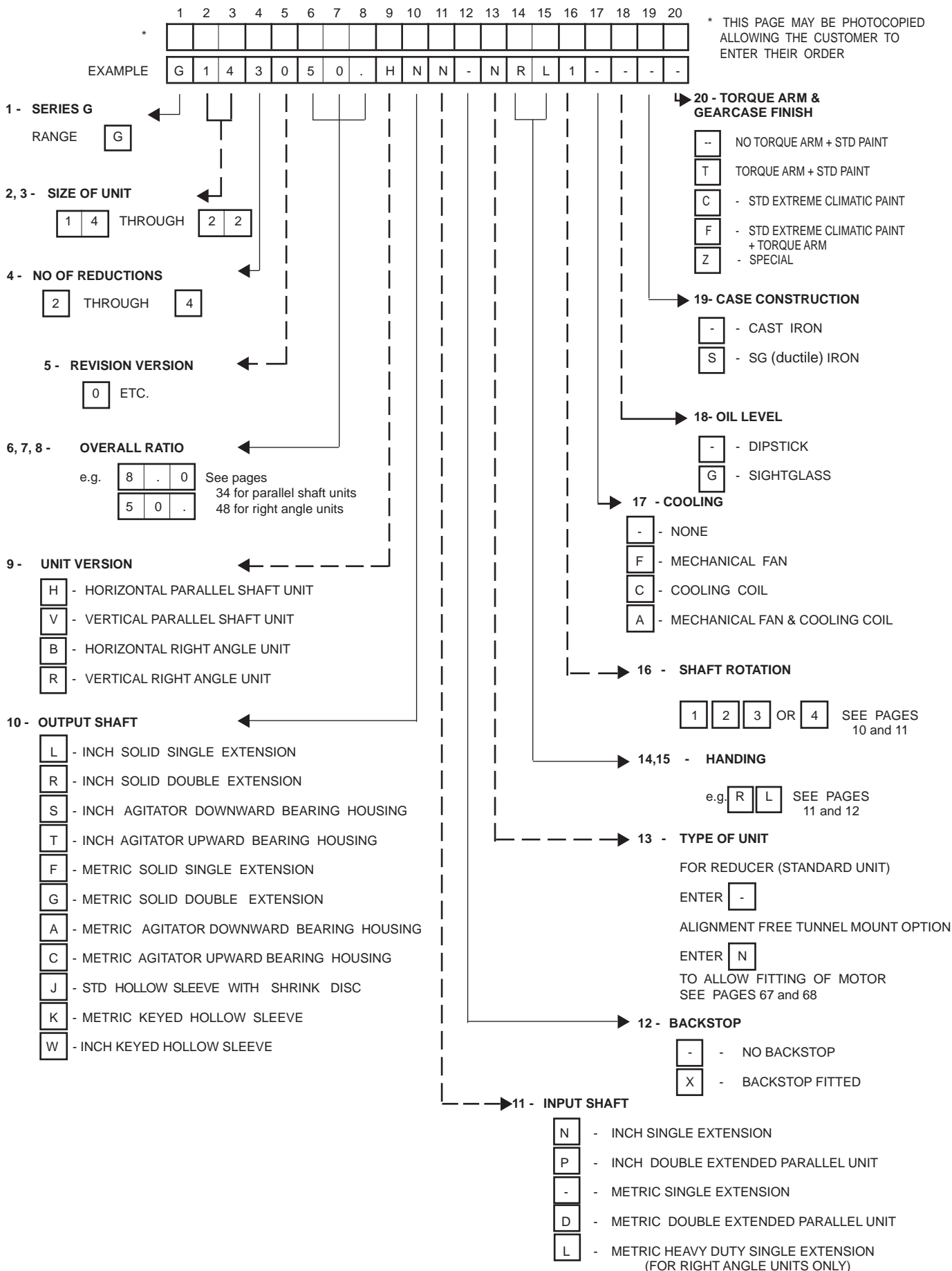

DESIGN FEATURES

Shaft Mounted Units

Shaft mounted units can be mounted on the driven machine shaft extension and connected to the foundation by a torque arm, supplied as an optional extra.

Additionally, unit feet are available for mounting on a baseplate with motor and coupling, the complete assembly being mounted on the driven machine shaft extension and connected to the foundation by a torque arm.

Shaft mounted units are fitted with a 'shrink disc' device to provide positive clamping on the driven machine shaft extension.

Shaft mounted units with keyed sleeves may also be supplied for fitting on to a keyed shaft.

Motorized Gear Units

Gear units are available as standard assemblies comprising IEC standard metric (B5) flanged and NEMA C-Face motors directly mounted on the gearcase input shaft housings by adaptors. Motor and gear unit shafts are connected by flexible couplings.

Baseplates

Standard baseplates can be supplied for units with parallel or right angle shafts. Assemblies comprise of gear units and foot mounted motors correctly aligned in manufacture and connected by our couplings. Coupling guards are fitted.

Baseplates for right angle shaft gear units are designed for use with either foot or shaft mounted arrangements, and provision is made for attaching torque arms where required.

Designs provide ample stiffness to prevent distortion under load. Full details are available from our Application Engineers.

Backstops

Externally mounted Backstops can be fitted to all Series G gear units, when required to operate in non-reversing drives. They are located on the helical pinion shaft and have adequate capacities to deal with full rated torques. All backstops are centrifugal lift off type. Changing the direction of locking rotation is a simple operation. If required, a torque limiting backstop with controllable tension release can be fitted to all units (consult our Application Engineers).

Preservation / Protection

Series G gear units are shipped without oil.

Prior to shipping they are test run with a rust preventative oil giving adequate protection to internal parts for a period of six months covering normal transport and covered storage.

Shaft extensions and hollow output shafts are protected with a rust inhibitor which is protection against sea water and suitable for under-cover storage up to 12 months.

Note: Where gear units are to operate in abnormal conditions, or where they are to stand for long periods without running, e.g. in plant installation, we must be notified so that suitable protective arrangements can be made.

DESIGN FEATURES

Gears

High quality alloy case hardening materials provide long life wear resistance and fatigue strength.

Profile ground single helical gears and hard finished spiral bevel gears ensure high standards of accuracy, Surface finish and quiet running characteristics. Helical gears are fitted in parallel shaft units. Units with shafts at right angles incorporate spiral bevel and helical gears.

Gearcases

Standard gearcases are of rigid cast iron construction with modern styling, special cases can be supplied as SG (ductile) iron or fabricated steel.

Horizontal split case design for ease of maintenance.

Gearcase design using finite element analysis to give high strength to weight ratio.

Inspection cover provided for viewing gear contacts.

Oil level dipstick, ventilator and drain plugs are installed.

With an option to install an oil level sight glass.

Gearcase Finish

Gearcase housings are shot blasted prior to painting.

Standard Paint System - Alkyd enamel.

Optional Paint System for Extreme Climatic and Environmental Conditions - Two part epoxy.

Both paint systems are resistant to dilute acids and alkalis, oils and solvents, sea water and temperatures up to 280°F.

External Dimensions

Shaft extensions are to inch or metric dimensions. Fasteners are metric.

Lubrication

Lubrication in most instances is by the transfer of oil by gears dipping in the sumps of gear unit bases. Where high pitch line speeds could cause churning of the lubricant. Spray lubrication is necessary where shown and complete systems can be supplied when required.

The unit oil grade and change period will be stamped on the nameplate. The change period will be 6 months for mineral oil based lubricants and 18 months for synthetic oil based lubricants. These figures assume a sump temperature of 230°F. Oil change periods can be extended for lower sump temperatures see installation and maintenance leaflet.

Units are provided with a dipstick, ventilator and drain plugs.

Cooling

Depending on the application standard gear units are cooled by:-

Normal heat dissipation by convection from external surfaces.

Mechanical fan fitted to high speed shaft.

Cooling water coil fitted in gear unit base.

Fan and cooling coil.

Separate oil cooler incorporated in forced lubrication system.

As improvements in design are being made continually this specification is not to be regarded as binding in detail and drawings and capacities are subject to alteration without notice. Certified drawings will be sent on request.

SERIES G

EXPLANATION AND USE OF RATINGS AND ASSOCIATED RATING FACTORS

Gear unit selection is made by comparing actual loads with catalog ratings. Gear ratings are based upon DIN standards. Catalog ratings are based on a standard set of loading conditions, whereas actual load conditions vary according to type of application. Service Factors are therefore used to calculate an equivalent load to compare with catalog ratings. i.e. Equivalent Load = Actual Load x Service Factor

Mechanical and Thermal Service Factor must be considered:- Mechanical Service Factors Fm and Fs
Thermal Service Factors Ft, Fd, Fh and Fv

Mechanical ratings and service factors Fm and Fs

Mechanical ratings measure capacity in terms of life and/or strength, assuming 10 hr/day continuous running under uniform load conditions.

Catalog ratings allow 100% overload at starting, braking or momentarily during operation up to 10 times per day.

The unit selected must therefore have a catalog rating at least equal to half maximum overload.

Mechanical Service Factor Fm (Table 1) is used to modify the actual load according to daily operating time, and type of loading. Required mechanical power rating P(mech) = absorbed power x Fm

Load characteristics for a wide range of applications are detailed in Table 3 opposite, which are used in deciding the appropriate Service Factor Fm from Table 1.

If loading can be calculated, or accurately assessed, actual loads should be used instead modifying using Fm.

For units subject to torque reversal or frequent stop/start overloads in excess of 10 times per day, the following check should be made

$$\text{gear unit input power capacity (Hp)} \geq \frac{T_m \times F_s \times n}{2 \times 63000}$$

Where Tm = motor starting torque (In-lb) or rating of torque limiting device, fluid coupling etc.

n = input speed (rev/min)

Fs = number of starts factor (See table 2)

For applications where high inertia loads are involved e.g. crane travel drives, slewing motion etc., or when units are to operate in extremely dusty or moist/humid atmospheres, unit selection should be referred to our Application Engineers.

Table 1. Mechanical Service Factor (Fm)

Prime Mover	Duration of service hours per day	Load classification-driven machine		
		Uniform	Moderate Shock	Heavy Shock
Electric motor, stream turbine or hydraulic motor	Under 3	1.00	1.00	1.50
	3 to 10	1.00	1.25	1.75
	Over 10	1.25	1.50	2.00
Multi-cylinder internal combustion engine	Under 3	1.00	1.25	1.75
	3 to 10	1.25	1.50	2.00
	Over 10	1.50	1.75	2.25
Single cylinder internal combustion engine	Under 3	1.25	1.50	2.00
	3 to 10	1.50	1.75	2.25
	Over 10	1.75	2.00	2.50

Table 2. Number of Starts Factor (Fs)

Start / Stops per hour (1)	Up to 1	5	10	40	60	≥200
Unidirectional	1.0	1.03	1.06	1.10	1.15	1.20
Reversing	1.4	1.45	1.50	1.55	1.60	1.70

Note: (1) Intermediate values are obtained by linear interpolation

SERIES G

EXPLANATION AND USE OF RATINGS AND ASSOCIATED RATING FACTORS

Thermal ratings and service factors

The Thermal ratings are a measure of the gear units ability to dissipate heat. If they are exceeded the lubricant may overheat and breakdown, resulting in gear failure.

Thermal ratings are given on page 40 for parallel shaft units and page 54 for right angle shaft units. The following choices are available:

- i) No additional cooling
- ii) Unit fitted with fan cooling
- iii) Unit fitted with water cooling coil
- iv) Unit fitted with cooling coil and fan

Catalog thermal limitations are based on the unit operating continuously in an environment with an ambient temperature equal to 77°F and in a horizontal mounting position. The thermal rating is affected by ambient temperature, duration of running per hour, altitude and operating area. To account for these varying conditions, the service factors given in tables 4, 5, 6 and 7 should be applied as follows:-

$$P_{\text{therm}} = \frac{\text{Absorbed Power}}{F_t \times F_d \times F_h \times F_v}$$

- P_{therm} = Required thermal rating (Hp)
- F_t = Service factor for ambient temperature (see Table 4)
- F_d = Service factor for intermittent duty (see Table 5)
- F_h = Thermal service factor for altitude (see Table 6)
- F_v = Thermal service factor for air velocity correction (operating area) (see Table 7)

Table 4. Ambient Temperature Adjustment Factor (Ft)

Unit Type	Ambient Temperature °F (°C)							
	-4°F (-20°C)	14°F (-10°C)	32°F (0°C)	60°F (15°C)	77°F (25°C)	86°F (30°C)	95°F (35°C)	112°F (45°C)
All Units	1.65	1.50	1.35	1.14	1.00	0.93	0.86	0.71

Table 5. Intermittent Duty Factor (Fd)

Unit Output Speed (rev/min)	% Running time per hour				
	100	80	60	40	20
0 to 10	1.00	1.18	1.45	1.72	2.38
>10 to 25	1.00	1.16	1.39	1.64	2.22
>25 to 50	1.00	1.14	1.31	1.54	2.00
>50 to 100	1.00	1.08	1.19	1.33	1.64
>100 to 150	1.00	1.04	1.08	1.19	1.41
>150 to 200	1.00	1.00	1.00	1.06	1.23
>200	1.00	1.00	1.00	1.00	1.00

Table 6. Altitude Adjustment Factor (Fh)

Altitude (m) (ft)	Factor Fh
Sea Level	1.0
500 (1640')	0.97
1000 (3280')	0.93
1500 (4921')	0.90
2000 (6562')	0.87
3000 (9843')	0.81
4000 (13123')	0.75
5000 (16404')	0.70

Table 7. Ambient Air Velocity Correction Factor (Fv)

Use FV = 1.0 For Units with Fan Cooling

Operating Area	If Vv is not known use this value for Fv	Air Velocity Vv m/sec (mph)	Factor Fv If Vv is known use this formula for Fv
Small confined space (no Fan)	0.86	0 - 1.4 (0 - 3 mph)	$F_v = 0.1 V_v + 0.86$
Large indoor space (& fan cooled)	1.0	> 1.4 - < 6 (3 - 14 mph)	$F_v = 0.2 V_v + 0.72$
Sheltered outdoor space (no fan)	1.3	> 2 - < 6 (5 - 14 mph)	$F_v = 0.17 V_v + 0.9$
Outdoor space (no fan)	1.5	> 2 (5mph)	$F_v = 0.17 V_v + 0.9$ (max Fv = 1.92)

General

When checking thermal capacities of units, use actual load required to be transmitted, not rating of prime mover.

SERIES G

EXPLANATION AND USE OF RATINGS

AND ASSOCIATED RATING FACTORS

Table 3

U = Uniform load

M = Moderate shock load

H = Heavy shock load

† = Refer to Application Engineering

Driven Machine	type of load	Driven Machine	type of load	Driven Machine	type of load
Cranes		Cranes		Cranes	
main hoists	+	log haul-incline	H	log haul	H
bridge travel	†	log haul-well type	H	presses	M
trolley travel	†	log turning device	H	pulp machine reel	M
		main log conveyor	H	stock chest	M
		off bearing rolls	M	suction roll	M
Crusher		planer feed chains	M	washers and thickeners	M
ore	H	planer floor chains	M	winders	M
stone	H	planer tilting hoist	M		
sugar	H	re-saw merry-go-round		Printing presses	†
		conveyor	M		
Dredges		roll cases	H	Pullers	
cable reels	M	slab conveyor	H	barge haul	H
conveyors	M	small waste			
cutter head drives	H	conveyor-belt	U	Pumps	
jig drives	H	small waste		centrifugal	U
maneuvering winches	M	conveyor-chain	M	proportioning	M
pumps	M	sorting table	M	reciprocating	
screen drive	H	tipple hoist conveyor	M	single acting; 3 or	
stackers	M	tipple hoist drive	M	more cylinders	M
utility winches	M	transfer conveyors	M	double acting; 2 or	
		transfer rolls	M	more cylinders	M
Dry dock cranes		tray drive	M	single acting; 1 or 2	
main hoist	+	trimmer feed	M	cylinders	†
auxiliary hoist	†	waste conveyor	M	double acting; single	
boom, luffing	†			cylinder	†
rotating, swing or slew	†	Machine tools		rotary	
tracking, drive wheels	†	bending roll	M	gear type	U
		punch press-gear driven	H	lobe, vane	U
		notching press- belt			
Elevators		driven	†	Rubber and plastics	
bucket-uniform load	U	plate planers	H	industries	
bucket-heavy load	M	tapping machine	H	crackers	H
bucket-continuous	U	other machine tools		laboratory equipment	M
centrifugal discharge	U	main drives	M	mixed mills	H
escalators	U	auxiliary drives	U	refiners	M
freight	M			rubber calenders	M
gravity discharge	U	Metal mills		rubber mill-2 on line	M
man lifts	†	draw bench carriage		rubber mill-3 on line	M
passenger	†	and main drive	M	sheeter	M
		pinch, dryer and		tire building machines	†
Fans		scrubber rolls-reversing	†	tire and tube press	
centrifugal	U	slitters	M	openers	†
cooling towers		table conveyors		tubers and strainers	M
induced draft	+	non-reversing		warming mills	M
forced draft	†	group drives	M		
induced draft	M	individual drives	H	Sand muller	M
large, mine, etc	M	reversing			
large, industrial	M	wire drawing and		Sewage disposal	
light, small diameter	U	flattening machine	M	equipment	
		wire winding machine	M	bar screens	U
Feeders				chemical feeders	U
apron	M	Mill-rotary type		collectors	U
belt	M	ball	H	dewatering screws	M
disc	U	cement kilns	H	scum breakers	M
reciprocating	H	dryers and coolers	H	slow or rapid mixers	M
screw	M	kilns, other than cement	H	thickeners	M
		pebble	H	vacuum filters	M
Food industry		rod			
beef slicer	M	Mixers		Screens	
cereal cooker	U	concrete mixers		air washing	U
dough mixer	M	-continuous	M	rotary-stone or gravel	M
meat grinders	M	concrete mixers		travelling water intake	U
		-intermittent	M		
Generators-not		constant density	U	Slab pushers	M
welding	U	variable density	M		
		Oil industry		Steering gear	†
Hammer mills	H	chillers	M		
		oil well pumping	†	Stokers	U
Hoists		paraffin filter press	M		
heavy duty	H	rotary kilns	M	Sugar industry	
medium duty	M			cane knives	M
skip hoist	M	Paper mills		crushers	M
		agitators, (mixers)	M	mills	M
Laundry washers		barker-auxiliaries-			
reversing	M	hydraulic	M	Textile industry	
		barker-mechanical	†	batchers	M
Laundry tumblers	M	barking drum	H	calenders	M
		beater and pulper	M	cards	M
Line shafts		bleacher	U	dry cans	M
driving processing		calenders	M	dryers	M
equipment	M	calenders-super	H	dyeing machinery	M
light	U	converting machine,		knitting machines	†
other line shafts	U	except cutters, platers	M	looms	M
		conveyors	U	mangles	M
Lumber industry		couch	M	nappers	M
barkers-hydraulic-		cutters-plates	H	pads	M
mechanical	M	cylinders	M	range drives	†
burner conveyor	M	dryers	M	slashers	M
chain saw and drag saw	H	felt stretcher	M	soapers	M
chain transfer	H	felt whipper	H	spinners	M
craneway transfer	H	jordans	M	tenter frames	M
de-barking drum	H			washers	M
edger feed	M			winders	M
gang feed	M				
green chain	M			Windlass	†
live rolls	H				
log shaker	H				

SELECTION PROCEDURE

EXAMPLE APPLICATION DETAILS

Absorbed power of driven machine = 120 HP
 Output speed of gearbox or Input speed of machine = 81 rev/min
 Application = Uniformly loaded belt conveyor operating in a large indoor space
 Duration of service (hours per day) = 24hrs
 Motor speed = 3 phase electric motor, 4 pole, 1750 rev/min
 Mounting position = Horizontal, Right Angle Shaft
 Ambient temperature = 86°F (30°C)
 Running time (%) = 100%
 Altitude = Sea Level

1 DETERMINE RATIO OF GEARBOX REQUIRED

$$\frac{\text{Motor speed}}{\text{Gearbox output speed}} = \frac{1750}{81} = 21.605$$

Refer to exact ratios (page 49) for nearest nominal ratio = 22

3 DETERMINE REQUIRED MECHANICAL OUTPUT TORQUE CAPACITY OF GEARBOX

Required mechanical = Absorbed power x Fm rating (P_{mech})

$$P_{mech} = 120 \times 1.25 = 150 \text{ HP}$$

2 DETERMINE MECHANICAL SERVICE FACTOR (F_m)

Refer to Load Classification by Application, table 3, page 7

Application = Uniformly loaded belt conveyor

Conveyors-uniformly loaded or fed

apron	U	U = Uniform load
assembly	U	
belt	U	
bucket	U	
chain	U	

Refer to mechanical service factor (F_m), table 1, page 5

Duration of service (hours per day) = 24hrs

Prime mover	Duration of service-hrs per day	Load classification-drive	
		Uniform	Moderate Shock
Electric motor, steam turbine or hydraulic motor	Under 3	1.00	1.00
	3 to 10	1.00	1.25
	Over 10	1.25	1.50

Therefore mechanical service factor (F_m) = 1.25

4 DETERMINE SIZE OF GEAR BOX REQUIRED

Unit input power capacity ≥ P_{mech}

Refer to ratings tables, Input speed = 1750rev/min, therefore refer to page 49.

NOMINAL RATIO	NOMINAL OUTPUT SPEED REV / MIN	CAPACITY	RIGHT ANGLE UNIT - SIZE			
			G14	G15	G16	G17
22.	79.5	Input Power - HP	112	166	282	393
		Output Torque - lb-in	84956	123894	212389	312389

Mechanical input power capacity must be equal or more than required mechanical input power capacity of the gear box (P_{mech}). Required mechanical input power = 150 HP. At a 22:1 ratio, nominal output speed 79.5 a G15 unit has a mechanical input power capacity of 166 HP. Therefore the unit is acceptable.

If the unit is subject to torque reversal or frequent stop /starts the input power capacity must be checked in accordance with the formulae on page 5.

5 DETERMINE EXACT RATIO OF GEARBOX

Refer to exact ratios table, page 48

Nominal Ratio Column Entry	14	15	16	17
6 7 8				
2 2 .	21.775	21.541	21.756	22.894
Exact ratio =	21.541			

Go to point 6 page 9

SELECTION PROCEDURE

6 DETERMINE THERMAL SERVICE FACTOR (Ft)

Refer to table 4, page 6
Ambient temperature = 86°F (30°C)

Ambient temperature °C	-4 (-20°C)	-14 (10 °C)	32 (0 °C)	60 (15 °C)	77 (25 °C)	86 (30 °C)
Factor Ft	1.57	1.43	1.29	1.14	1.00	0.93

Ft = 0.93

7 DETERMINE THERMAL SERVICE FACTOR (Fd)

Refer to table 5, page 6
Unit running time per hour = 100%
Nominal output speed (rev/min) = 80

Unit Output Speed (rev/min)	% Running time per hour	
	100	80
>10 to 25	1.0	1.16
>25 to 50	1.0	1.14
>50 to 100	1.0	1.08

Fd = 1.0

8 DETERMINE ALTITUDE ADJUSTMENT THERMAL SERVICE FACTOR (Fh)

Refer to table 6, page 6

Altitude (m)	Factor Fh
Sea Level	1.0
500	0.97
1000	0.93

Fh = 1.0

9 DETERMINE AMBIENT AIR VELOCITY FACTOR (Fv)

Use Fv = 1.0 For Units with Fan Cooling

Operating Area	If Vv is not known use this value for Fv	Air Velocity Vv m/sec	Factor Fv If Vv is known use this formula for Fv
Small confined space	0.86	0 - 1.4	$Fv = 0.1 Vv + 0.86$
Large indoor space	1.0	> 1.4 - < 6	$Fv = 0.2 Vv + 0.72$

Fv = 1.0

10 CALCULATE REQUIRED THERMAL RATING Ptherm

$$P_{therm} = \frac{\text{Absorbed Power (Hp)}}{F_t \times F_d \times F_h \times F_v}$$

$$P_{therm} = \frac{120}{0.93 \times 1.0 \times 1.0 \times 1.0}$$

$$P_{therm} = 129 \text{ HP}$$

11 CHECK THERMAL CAPACITY

See Page 54

Thermal Rating \geq Ptherm

Thermal Ratings HP

Right Angle Shaft Units - Triple Reduction

Type of Cooling	Input Speed (rev/min)	Ratio	G1430	G1530	G1630
No Additional Cooling	875	12:1	82	86	141
		25:1	64	71	120
		56:1	41	49	86
Fan Cooling	1750	12:1	240	243	386
		25:1	206	216	350
		56:1	149	167	282
	1450	12:1	212	215	347
		25:1	181	190	314
		56:1	129	145	250
	1160	12:1	185	188	308
		25:1	157	165	277
		56:1	111	125	219
	875	12:1	163	167	277
		25:1	137	146	248
		56:1	96	109	194
Cooling Coil	1750	12:1	233	242	377
		25:1	199	215	342
		56:1	142	165	275

Ptherm = 129 HP
therefore unit requires cooling.

Thermal rating for the nearest fan cooled G15 unit is

25:1 ratio = 216 HP.

Thermal capacity is therefore acceptable.

12 CHECK OVERHUNG LOADS

If sprocket, gear, etc is mounted on the input or output shaft then refer to Overhung loads procedure, pages 28 - 29

13 CHECK COUPLING HUB CAPACITIES

NOTE: It is advisable that all selections are verified by our Application Engineers.

If any of the following conditions occur then our Application Engineers must be consulted:-

- a) Inertia of the Driven Machine (Referred to motor speed) >1.0
Inertia of Gear Unit plus Motor
- b) Ambient temperature is above 122°F (50°C)

SERIES G

UNIT HANDINGS & SHAFT ROTATIONS

PARALLEL SHAFT UNITS

Column 14 Entry - Output Shaft Positions

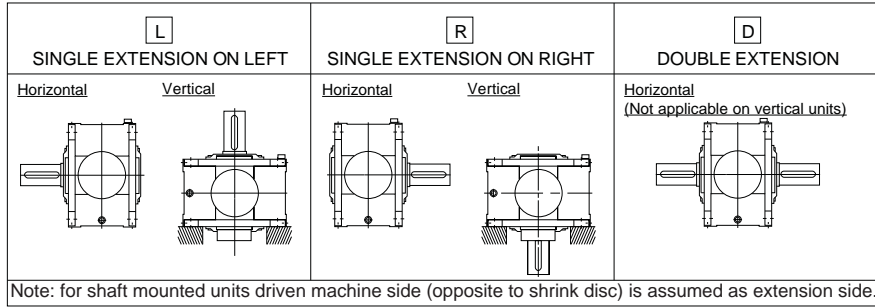

Column 16 Entry - Shaft Rotations

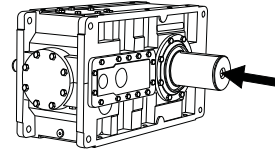

Rotation directions are defined as viewed from output shaft end** (This side if double extended or keyed hollow sleeve)

** Driven machine side for shaft mounted units, opposite side to shrink disc.

Rotation		Parallel Shaft	
Outputshaft	Inputshaft	2 Stage & 4 Stage	3 Stage
Clockwise	Clockwise	1 (std)	n/a
Anticlockwise	Anticlockwise	2	n/a
Clockwise	Anticlockwise	n/a	1 (std)
Anticlockwise	Clockwise	n/a	2

All units are rotation reversible, except when fitted with a backstop (anti-runback device).

(std) if no rotation is entered rotation will be assumed as standard build.

Column 15 Entry - Input Shaft Positions

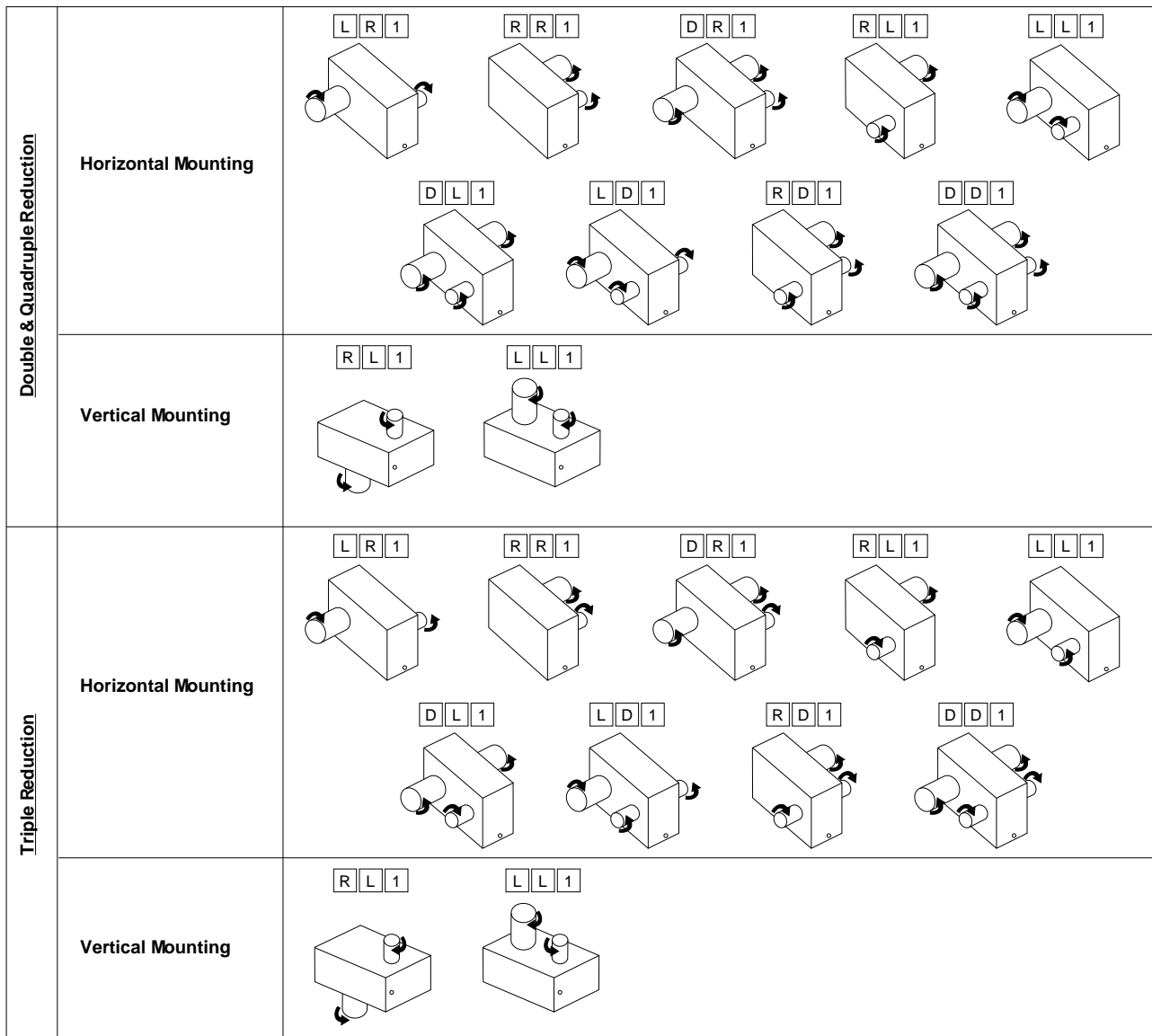
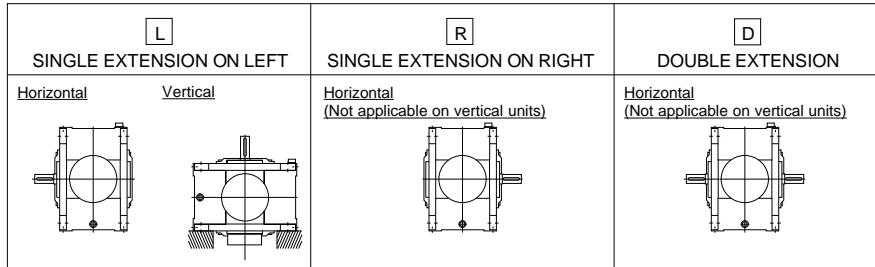

Note: parallel shaft unit handings **R R** or **L L** are subject to a reduction in external overhung load capacities

SERIES G

UNIT HANDINGS & SHAFT ROTATIONS

RIGHT ANGLE SHAFT UNITS

Column 14 Entry - Output Shaft Positions

L	R	D
SINGLE EXTENSION ON LEFT	SINGLE EXTENSION ON RIGHT	DOUBLE EXTENSION
Horizontal Vertical	Horizontal Vertical	Horizontal (Not applicable on vertical units)
Note: for shaft mounted units driven machine side (opposite to shrink disc) is assumed as extension side.		

Column 16 Entry - Shaft Rotations

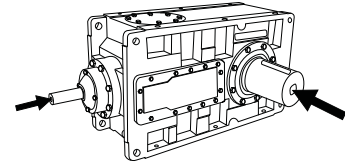

Rotation directions are defined as viewed from output shaft end** (This side if double extended or keyed hollow sleeve)

** Driven machine side for shaft mounted units, opposite side to shrink disc.

Column 15 Entry - Input Shaft Positions

B	J
STANDARD RIGHT ANGLE EXTENSION	RIGHT ANGLE UNIT TYPE J
Horizontal Vertical	Horizontal Vertical
Only available for ratios: G14, G16, G18 - Ratios 22 to 63 G15, G17, G19, G22 - Ratios 28 to 80 G21 - Ratios 25 - 71	

Rotation		Right Angle Shafts
Outputshaft	Inputshaft	3 Stage & 4 Stage
Clockwise	Clockwise	1 (std)
Anticlockwise	Anticlockwise	2
Clockwise	Anticlockwise	3 *
Anticlockwise	Clockwise	4 *

All units are rotation reversible, except when fitted with a backstop (anti-runback device).

(std) if no rotation is entered rotation will be assumed as standard build.

Right Angle Shafts - Triple & Quadruple Reduction	L B 1	R B 1	D B 1
Vertical Mounting	R B 1	L B 1	
Type J Shafts - Triple Reduction	L J 1	R J 1	D J 1
Vertical Mounting	R J 1	L J 1	

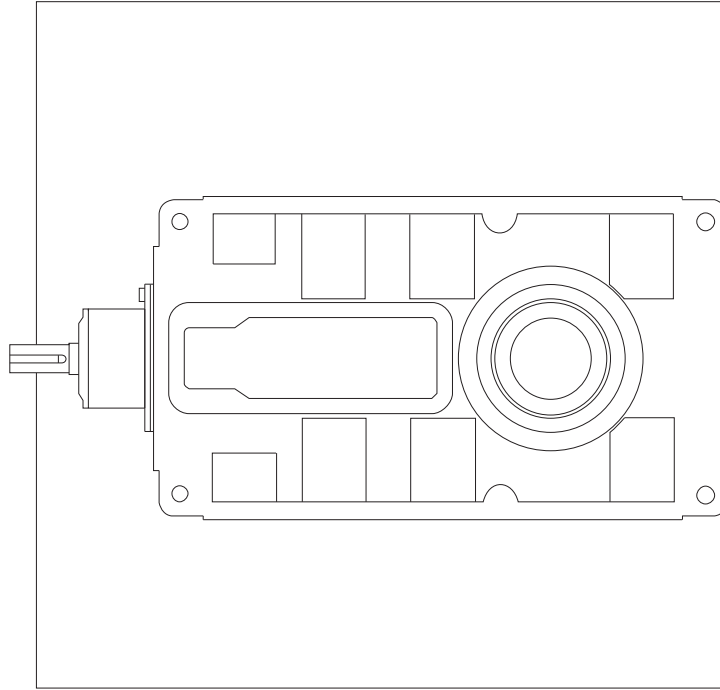

**INSTALLATION,
MAINTENANCE,
LUBRICATION**

SERIES G

INSTALLATION & MAINTENANCE

General

The following instructions will help you achieve a satisfactory installation of your Series G unit, ensuring the best possible conditions for a long and trouble free operation.

WARNING: The customer shall be responsible for the proper use of articles supplied by the company, particularly the rotating shafts between their driving and driven members, and their guarding for safety, and the company shall not be responsible for any injury or damage sustained as a result of the improper use of the articles supplied.



Attention is hereby drawn to the danger of using exposed lights in proximity to openings in gearboxes and gear units supplied by the company, and the company shall not be liable for any claim for injury or damage arising from any action in contravention of this warning.

WARNING: All units and couplings are shipped without oil or grease, on installing the unit fill with recommended lubricant to correct level.

1.0 FITTING OF COMPONENTS TO EITHER THE UNIT INPUT OR OUTPUT SHAFT

The input or output shaft extension diameter tolerance is + 0 to - 0.0005 inches for shafts up to 1.5 inches diameter and +0 to -0.001 for shafts larger than 1.5 inches diameter. The fitted component should be machined to ensure a proper fit.

- Items (such as gears, sprockets, couplings etc) should not be hammered onto these shafts since this would damage the shaft support bearings.
- The item should be pushed onto the shaft using a screw jack device fitted into the threaded hole provided in the end of the shaft.
- Items being fitted maybe heated to 176/212°F (80/100°C) to aid assembly further.

THREADED HOLE DETAILS

UNIT SIZE	TYPE OF UNIT	INPUT SHAFT	OUTPUT SHAFT
14 & 15	Parallel 2 Stage	5/8" UNF x 1.25 deep	1" UNF x 2 deep
	Parallel 3 & 4 Stage	1/2" UNF x 1 deep	
	Right Angle 3 Stage	5/8" UNF x 1.25 deep	
16 & 17	Parallel 2 Stage	3/4" UNF x 1.62 deep	1.25" UNF x 2.5 deep
	Parallel 3 & 4 Stage	5/8" UNF x 1.25 deep	
	Right Angle 3 Stage	5/8" UNF x 1.25 deep	
	Right Angle 4 Stage	5/8" UNF x 1.25 deep	
18 & 19	Parallel 2 Stage	1" UNF x 2 deep	1.5" UNF x 3 deep
	Parallel 3 & 4 Stage	3/4" UNF x 1.62 deep	
	Right Angle 3 Stage	3/4" UNF x 1.62 deep	
	Right Angle 4 Stage	5/8" UNF x 1.25 deep	
21 & 22	Parallel 2 Stage	1" UNF x 2 deep	1.5" UNF x 3 deep
	Parallel 3 & 4 Stage	3/4" UNF x 1.62 deep	
	Right Angle 3 Stage	1" UNF x 2 deep	
	Right Angle 4 Stage	3/4" UNF x 1.62 deep	

2.0 WEATHER PROTECTION OF UNIT

All Series G units are provided with protection against normal weather conditions. Where units are to operate in extreme conditions, or where they are to stand for long periods without running, e.g. during plant construction, we should be notified when ordering so that arrangements for adequate protection can be made.

INSTALLATION & MAINTENANCE

3.0 INSTALLATION

All units are shipped less oil, for the customer to fill on site once installed. Care should be taken to ensure the correct type and quantity of lubricant for the chosen mounting position is used. Ensure that the breather/filling plug, dipstick and drain plugs are installed in the correct position

- Page 19 gives approximate lubricant quantities for each mounting position
- Pages 19 and 20 show a list of lubricants approved for use in the gear unit.
- See appropriate dimension page for positions of breather/filling plug, dipstick and drain plugs

3.1 LIFTING

Only the lifting points identified on the gearbox or bedplate must be used for lifting operations during installation.

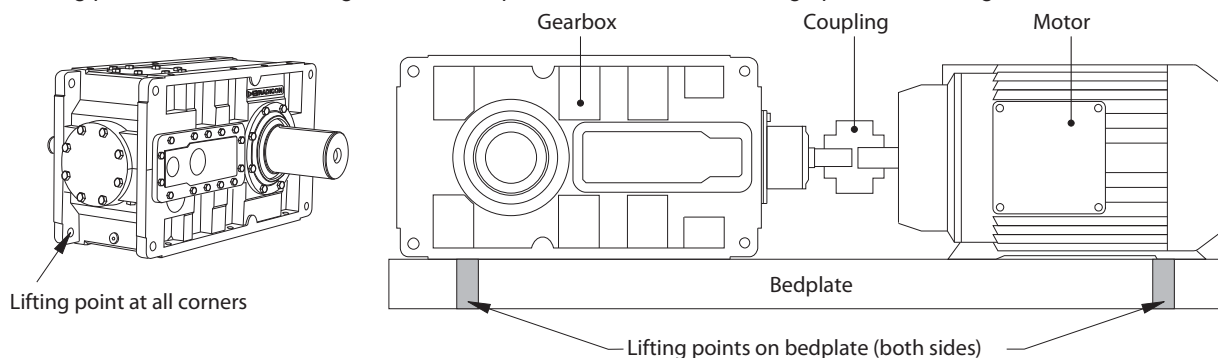

Gearbox Only

The gearbox can be lifted using any of the eight lifting points.

Note:

Gearbox on Bedplate

The lifting points on the bedplate must be used to lift the whole drive assembly. Do NOT use the lifting points on the gearbox to lift the bedplate assembly.

Failure to use these lifting points could result in personal injury/or damage to the product and surrounding equipment

3.2 GENERAL

Drives must be installed on rigid, flat and vibration free beds. Align the driving and driven units carefully to avoid any increased loads on the shafts and bearings due to misalignment.

The unit should be fixed by means of bolts to ISO grade 8.8 minimum or equivalent and torque tightened to:

Screw Size	Tightening Torque
1/2" (M12)	750 lb-ins (85 Nm)
5/8" (M16)	1770 lb-ins (200 Nm)
3/4" (M20)	3100 lb-ins (350 Nm)
1" (M20)	5400 lb-ins (610 Nm)
1 1/4" (M30)	10,800 lb-ins (1220 Nm)
1 1/2" (M36)	19,030 lb-ins (2150 Nm)
1 3/4" (M42)	30,600 lb-ins (3460 Nm)

3.3 GUARDS

The customer must ensure that any exposed rotating shafts and couplings, guards must be fitted in accordance with the relevant state and local safety regulations.

3.4 CONNECTING ELECTRIC MOTOR

Connection of the electric motor to the mains supply should be made by a qualified person. The current rating of the motor will be identified on the motor plate, and correct sizing of the cables to electrical regulations is essential.

INSTALLATION & MAINTENANCE

3.5 FOOT-MOUNTED UNITS

The following procedure is recommended for all foot mounted units. Foot mounted units are supplied either as free standing units, or if required, mounted on a standard baseplate with a foot mounted motor correctly aligned and connected by a flexible coupling.

- a) Clean shaft extensions and breather when fitted.
- b) Secure unit, or baseplate if fitted to a rigid foundation using heavy duty bolts to ISO grade 8.8 minimum or equivalent.
- c) Ensure baseplate is not distorted Note: Units not supplied on baseplates should if possible be mounted on the same bedplate as the prime mover.
- d) Align unit

Note: It is important to ensure when aligning unit on baseplate that all machined mounting points are supported over their full area. If steel shims are used these should be placed either side of the foundation bolt as close as possible. During the final bolting ensure the unit or baseplate is not distorted this will cause strains in the gear case resulting in errors of alignment of shafts and gearing.

- e) For units mounted on bedplates after alignment select any two diagonally opposite feet, drill ream and dowel in position.
- f) Fit guards in accordance with current local, state and federal regulations.
- g) Check motor wiring for correct direction of rotation this is important when a backstop device is fitted.
- h) Fill gear unit with oil as detailed on page 18 - 20.

3.6 SHAFT MOUNTED UNITS

The following procedure is recommended for all shaft and foot/shaft mounted units.

- a) Clean shaft extensions, driven machine shaft, gear unit bore and breather when fitted.
- b) Locate in position, ensuring it is as close as possible to the bearing on the driven machine.
- c) Secure unit onto the shaft. For units using a shrink disc device refer to section 3.6.1
- d) Fit torque arm to the side of the unit adjacent to the driven machine where possible, as detailed below. Note: Unless specified otherwise, the torque arm will be supplied loose.
- e) Anchor case to a secure point by means of the torque arm.
- f) Fit guards in accordance with current local, state and federal regulations.
- g) Check motor wiring for correct direction of rotation, this is important when a backstop device is fitted.
- h) Fill gear unit with oil as detailed on page 18 - 20.

Figure 1

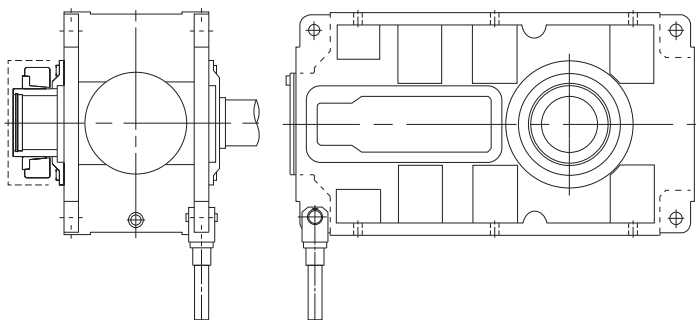
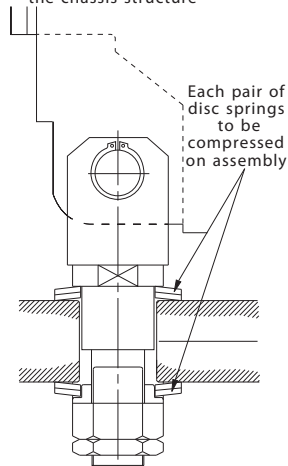

Figure 2

The torque arm must be flexibly mounted to the chassis structure



INSTALLATION & MAINTENANCE

3.6.1 SHAFT MOUNTED UNITS USING A SHRINK DISC DEVICE

The gear unit is fitted with a 'shrink disc' device located on the hollow output shaft to provide a positive outer locking connection between gear unit and driven shaft. The 'shrink disc' is a friction device without keys, which exerts an external clamping force on the hollow output shaft, thus establishing a mechanical shrink fit between the gear unit hollow shaft and driven shaft. 'Shrink disc' capacities have ample margins in dealing with transmitted torques and external loading imposed on gear units.

The 'shrink disc' consists of a locking collar, a tapered inner ring and locking screws. By tightening the locking screws, the locking collar and tapered inner ring are pulled together, exerting radial forces on the inner ring, thus creating a positive friction connection between hollow shaft and driven shaft (see figure 2).

As the tapered surfaces of locking collar and inner ring are lubricated with Molykote 321R or similar and the taper angle is not self locking, locking collar will not seize on the inner ring and can be released easily when removal is necessary.

When the 'shrink disc' is clamped in position the high contact pressures between tapered surfaces and screw heads and their seatings ensure hermetic sealing and eliminate the possibility of fretting corrosion.

INSTALLATION

'Shrink discs' are supplied with shaft mounted units. The following procedures should be followed when fitting or removing units from the driven shaft.

- 1 Release locking screws gradually and in succession. Initially a quarter of a turn on each screw will avoid tilting and jamming - do not remove locking bolts completely.
- 2 Remove 'shrink disc' - from gear unit hollow shaft.
- 3 Clean and degrease locating diameters of gear unit hollow shaft, driven shaft and 'shrink disc' locating diameter on hollow shaft extension.
- 4 Draw the gear unit onto the driven shaft (see figure 3)
- 5 Grease tapered surfaces of outer ring and inner ring with Molykote 321R or similar.
- 6 Fit 'shrink disc' on gear unit hollow shaft to position shown in figure 1 page 61.
- 7 Tighten all locking screws gradually and in succession. Do not tighten in a diametrically opposite sequence. Several passes are required until all screws are tightened until the inner and outer ring faces are in-line and the torque figures T_a shown in the table on page 61 are achieved.
- 8 Fit protective cover

Note: When the hollow output shaft is to operate in a vertical position it is essential that the shaft of the driven machine is provided with a shoulder. When the thrust load is not taken by the shoulder on the driven shaft, a thrust plate, as shown on page 61, must be fitted.

It is recommended that customers' shafts at the non-clamped end of the sleeve should be coated with Molykote 321R or equivalent.

REMOVAL

- 1 Removal procedure is similar to the reverse of installation.
- 2 Remove any rust and dirt from gear unit hollow shaft.
- 3 Withdraw gear unit from driven shaft (see figure 4)

Note: 'Shrink disc' should be removed and cleaned thoroughly, and Molykote 321R or similar applied to the tapered surfaces of inner ring and locking collar before re-use.

Note: Protective covers are supplied with all 'shrink discs'. Assembly or removal kits and thrust plates are not provided.

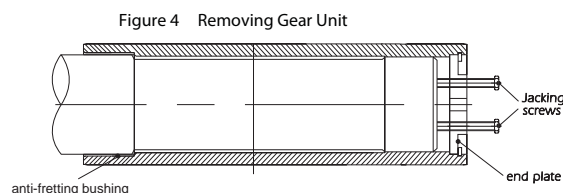
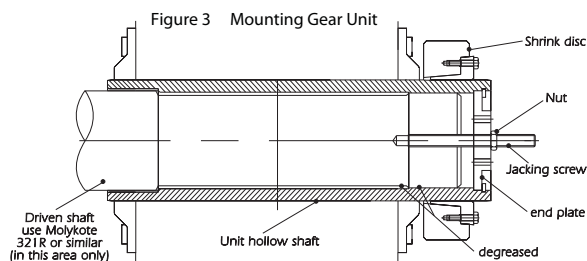
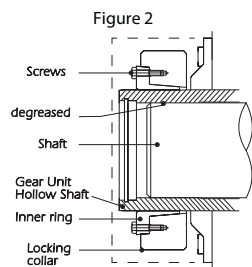

INSTALLATION & MAINTENANCE

3.7 OIL / GREASE CHANGES

On all sizes regular oil changes are essential and the following factors should be used to determine the frequency at which these are carried out.

- | | |
|---|--|
| a. Oil temperature - unit operating under load. | c. Environment - humidity, dust, etc. |
| b. Type of oil. | d. Operating conditions - shock, loading, etc. |

At elevated temperatures the effective life of the oil is very much reduced. This is most pronounced with oils containing fatty and E.P. additives. To prevent damage to the unit through lubricant breakdown the oil should be renewed as detailed in the following table:

UNIT OPERATING TEMPERATURE °F	RENEWAL PERIOD	
	MINERAL OIL	SYNTHETIC OIL
167 (75°C) OR LESS	17000 HOURS or 3 YEARS	26000 HOURS or 3 YEARS
176 (80°C)	12000 HOURS or 3 YEARS	26000 HOURS or 3 YEARS
185 (85°C)	8500 HOURS or 3 YEARS	21000 HOURS or 3 YEARS
194 (90°C)	6000 HOURS or 2 YEARS	15000 HOURS or 3 YEARS
203 (95°C)	4200 HOURS or 17 MONTHS	10500 HOURS or 3 YEARS
212 (100°C)	3000 HOURS or 12 MONTHS	7500 HOURS or 2.5 YEARS
NB: INITIAL FILL OF OIL SHOULD BE CHANGED IN A NEW GEAR UNIT AFTER 1000 HOURS OPERATION OR ONE YEAR OR HALF THE ABOVE LIFE WHICHEVER IS THE SOONEST		

3.7 OIL / GREASE CHANGES

On all sizes regular oil changes are essential and the following factors should be used to determine the frequency at which these are carried out.

Note:

Figures quoted are for oil temperatures when the unit has attained normal running temperature when operating under load. These figures are based on normal running but where conditions are particularly severe it may be necessary to change the oil more frequently. When changing lubricant, if same lubricant is not used then unit must be flushed out and filled only with one type of lubricant.

The procedure for changing an oil should be to drain the oil preferably when hot and after circulation. If the gear unit is to be flushed, the unit should be filled to the appropriate level with an oil of the same viscosity grade and type as the lubricating oil and run before the flushing oil is drained. This procedure should be followed especially if the type of oil is being changed. The unit should be filled with the approved oil to the level marked on the dipstick. Re-check the oil level after a short period of running and top up as necessary. On certain units the output shaft bearings are grease lubricated, these should be re-greased at 2000 to 3000 hour intervals unless otherwise instructed.

3.8 ROUTINE MAINTENANCE

Periodically check that the fixing bolts are properly tightened and that everything is correctly aligned.

Once a week the oil level should be checked and lubricant added if required. Carry out oil changes in accordance with the Table above. On certain units the output shaft bearings are grease lubricated, these should be re-greased at 2000 to 3000 hour intervals unless otherwise instructed.

3.9 CLEANING

With the drive stationary periodically clean any dirt or dust from the gear unit and the electric motor cooling fins and fan guard to aid cooling.

3.10 GENERAL SAFETY

Potential hazards which can be encountered during installation, maintenance and operation of drives is covered in greater detail in the Series G installation and maintenance booklet.

Any further information or clarification required may be obtained by contacting our Application Engineers.

FAULT DIAGNOSIS

TABLE 6 FAULT DIAGNOSIS

Symptom	Possible Causes	Remedy
Output shaft does not rotate, even though the motor is running or the input shaft is rotating.	Drive between shafts interrupted in the gear unit.	Return the gear unit / geared motor for repair.
Unusual, regular running noise	<ul style="list-style-type: none"> a) A meshing or grinding sound : damage to bearings b) A knocking sound : irregularity in gearing 	<ul style="list-style-type: none"> a) Check oil (See Maintenance) b) Contact our Application Engineers or your local Sales Office
Unusual, irregular running noise	Foreign matter present in the oil	<ul style="list-style-type: none"> a) Check oil (See Maintenance) b) Stop the unit, contact our Application Engineers or your local Sales Office
Oil leaking ¹ <ul style="list-style-type: none"> • from gear unit cover • from motor flange • from gear unit flange • from output end oil seal 	<ul style="list-style-type: none"> a) Defective gasket on gear unit cover b) Defective gasket c) Gear unit not ventilated 	<ul style="list-style-type: none"> a) Retighten screws on gear unit cover and observe gear unit. If still oil leaks contact our Application Engineers or your local Sales Office. b) Contact our Application Engineers or your local Sales Office. c) Vent the gear unit.
Oil leaking from the ventilator	<ul style="list-style-type: none"> a) Gear unit over filled with oil b) Gear unit installed in an incorrect mounting position c) Frequent cold starts (oil foaming) and/or high oil level 	<ul style="list-style-type: none"> a) Correct the oil level (See Lubrication) b) Correct the mounting position and check oil level (See Lubrication) c) Check the oil level (See Lubrication)

1) It is normal for small amounts of oil / grease to leak out of the oil seal during the running in period (24 hours running time)

When contacting our sales office please have the following information available:

- Nameplate data (complete)
- Type and extent of the problem encountered
- The time and the circumstances the problem occurred
- A possible cause

Any further information or clarification required may be obtained by contacting Our sales office, please see contact details at the back of this booklet.

All Series G units are shipped without oil (a warning label is attached), and therefore filled by the client. The grade and type of oil will be stamped on the nameplate in accordance with either of the types of oil from tables 2 and 3. Recommended oils are listed in the Approved Lubrication section. The oil change period shall be determined from clause 3.7 on page 17.

The approximate quantity of oil required is given in Table 1, but the unit should always be filled to the level marked on the dipstick or any other level indicator fitted (sight glass etc). Warning: Do not overfill the unit as this can cause leakage and overheating.

Where possible run the unit without load for a short time to circulate the lubricant thoroughly, then stop the unit and re-check the oil level after allowing the unit to stand for 10 minutes and if necessary top up to the correct mark on the dipstick or any other level indicator fitted (sight glass etc).

In addition where bearings are grease packed, the greases approved are NLGI grade 2 and recommended greases are listed in the Approved Lubrication section.

TABLE 1 LUBRICANT QUANTITY (Gallons)

Unit Type		UNIT SIZE							
		14	15	16	17	18	19	21	22
Parallel Shaft 2 Stage	Horizontal	5.81	5.28	12.42	11.10	24.30	25.10	47.55	42.53
	Vertical	4.76	4.76	10.57	9.77	21.13	22.45	36.98	39.62
Parallel Shaft 3 Stage	Horizontal	5.55	5.02	12.15	10.83	24.04	24.83	48.87	46.23
	Vertical	4.76	4.76	10.57	9.77	21.13	22.45	36.98	40.95
Parallel Shaft 4 Stage	Horizontal	5.55	5.02	12.15	10.83	24.04	24.83	48.87	46.23
	Vertical	4.76	4.76	10.57	9.77	21.13	22.45	36.98	40.95
Right Angle 3 Stage	Horizontal	5.55	5.02	12.42	11.10	24.30	25.10	48.87	46.23
	Vertical	5.28	5.28	11.36	10.30	22.98	24.30	36.98	44.91
Right Angle 4 Stage	Horizontal	-	-	12.68	11.36	24.83	25.36	50.19	46.23
	Vertical	-	-	11.89	10.30	23.51	23.51	36.98	48.87

TABLE 2 OIL GRADES

EP Mineral Oil (type E)

LUBRICANT	AMBIENT TEMPERATURE RANGE		
	23°F to 68°F (-5°C to 20°C)	32°F to 95°F (0°C to 35°C)	60°F to 122°F (20°C to 50°C)
Oil Grade	5E (VG 220)	6E (VG 320)	7E (VG 460)

TABLE 3 OIL GRADES

Polyalphaolefin based Synthetic (type H)

LUBRICANT	AMBIENT TEMPERATURE RANGE	
	-22°F to 95°F (-30°C to 35°C)	68°F to 122°F (20°C to 50°C)
Oil Grade	5H (VG 220)	6H (VG 320)

TABLE 4 APPROVED BEARING GREASES

SUPPLIER	DESIGNATION	ALLOWABLE OPERATING TEMPERATURE RANGE °F	
		ABOVE	TO
BP Oil International Limited	Energrease LS-EP	-22 (-30°C)	266 (130°C)
Caltex	Multifak EP	32 (0°C)	248 (120°C)
Castrol International	LMX Grease	-40 (-40°C)	302 (150°C)
	Spheerol AP	-22 (-30°C)	230 (110°C)
	Spheerol EPL	50 (10°C)	248 (120°C)
Klüber Lubrication	Klüberlub BE 41-542	-4 (-20°C)	284 (140°C)
Mobil Oil Company Limited	Mobilgrease XHP	-5 (15°C)	302 (150°C)
	Mobilith SHC	-4 (-20°C)	356 (180°C)
Omega Manufacturing Division	Omega 85	-40 (-40°C)	446 (230°C)
Optimol Ölwerke GmbH	Longtime PD	-49 (-45°C)	284 (140°C)
Shell Oils	Albida RL	-4 (-20°C)	302 (150°C)
	Alvania EP B	-4 (-20°C)	248 (120°C)
	Nerita HV	-22 (-30°C)	266 (130°C)
Texaco Limited	Multifak All Purpose EP	-22 (-30°C)	284 (140°C)

Notes: All the above greases are NLGI grade 2. Contact our application engineers if the unit is operating outside the range - 22°F to 122°F (-30°C - 50°C)

TABLE 4 APPROVED LUBRICANTS

Type E Mineral oil containing industrial EP additives. These have a high load carrying capacity.

SUPPLIER	LUBRICANT RANGE	See notes page 27	GRADE NUMBERS		
			5E	6E	7E
			23°F to 68°F (-5°C to 20°C)	32°F to 95°F (0°C to 35°C)	68°F to 122°F (20°C to 50°C)
Ampol Limited	Gearlube SP		SP220 (-1)	SP320 (-1)	SP460 (-1)
Batoyle Freedom Group	Remus		220 (-2)	320 (-2)	460 (-2)
Boxer Services Limited	Indus	e	220 (-10)	320 (-10)	460 (-10)
BP Oil International Limited	Energol GR-XF	c,e	220 (-16)	320 (-13)	460 (-1)
	Energol GR-XP	e	220 (-15)	320 (-10)	460 (-7)
Caltex	Meropa		220 (-4)	320 (-4)	460 (-4)
	RPM Borate EP Lubricant		220 (-7)	320 (-4)	460 (-7)
Carl Bechem GmbH	Berugear GS BM		220 (-20)	320 (-13)	460 (-10)
	Staroil G		220 (-13)	320 (-13)	460 (-10)
Castrol International	Alpha Max	c,e	220 (-19)	320 (-13)	460 (-10)
	Alpha SP	e	220 (-16)	320 (-16)	460 (-1)
Chevron International Oil Company Limited	Gear Comp EP (USA ver)		220 (-16)	320 (-13)	460 (-10)
	Gear CompEP (Eastern ver)		220 (-13)	320 (-13)	460 (-13)
	Ultra Gear		220 (-10)	320 (-7)	460 (-7)
Eko-Elda (Greece)	Gearlub		220 (-13)	320 (-10)	460 (-1)
Engen Petroleum Limited	Gengear		220 (-13)	320 (-10)	460 (-1)
Esso	Spartan EP	c	220 (-16)	320 (-13)	460 (-7)
Esso/Exxon	Spartan EP	h	220 (-12)	320 (-12)	460 (-4)
Fina	Giran		220 (-13)	320 (-10)	460 (-10)
Fuchs Lubricants (UK) Plc	Powergear			P/Gear (-16)	M460 (-4)
	Renogear V		220EP (-13)	320EP (-4)	460EP (-4)
	Renogear WE		220 (-7)	320 (-4)	400 (-4)
Fuchs Mineraloelwerke GmbH	Renolin CLPF Super	e	6 (-13)	8 (-10)	10 (-10)
Klüber Lubrication	Klüberoil GEM1		220 (-5)	320 (-5)	460 (-5)
Kuwait Petroleum International	Q8 Goya		220 (-16)	320 (-13)	460 (-10)
Lubrication Engineers Inc	Almasol Vari-Purpose Gear		607 (-18)	605 (-13)	608 (-10)
Mobil Oil Company Limited	Mobil gear 600 Series		630 (-13)	632 (-13)	634 (-1)
	Mobil gear XMP	c	220 (-19)	320 (-13)	460 (-7)
Omega Manufacturing Division	Omega 690	e		85w/140 (-15)	
Optimol Ölwerke GmbH	Optigear BM		220 (-11)	320 (-10)	460 (-7)
	Optigear		220 (-18)	320 (-9)	460 (-7)
Pertamina (Indonesia)	Masri	e	220 (-4)	320 (-4)	460 (-4)
Petro-Canada	Ultima EP	e	220 (-22)	320 (-16)	460 (-10)
Petromin Lubricating Oil Co.	Gear Lube EP	e	EP220 (-1)	EP320 (0)	EP460 (0)
Rocol	Sapphire Hi-Torque	e	220 (-13)	320 (-13)	460 (-13)
Sasol Oil (Pty) Limited	Cobalt	e	220 (-4)	320 (-1)	460 (-4)
	Hemat	e	220 (-10)	320 (-7)	460 (-4)
Shell Oils	Omala		220 (-4)	320 (-4)	460 (-4)
	Omala F	c	220 (-13)	320 (-10)	460 (-4)
Texaco Limited	Meropa	c	220 (-11)	320 (-11)	460 (-5)
	Meropa WM	c	220 (-19)	320 (-16)	460 (-10)
Total	Carter EP		220 (-7)	320 (-7)	460 (-4)
Tribol GmbH	Molub-Alloy Gear Oil		90 (-18)	690 (-16)	140 (-13)
	Tribol 1100		220 (-20)	320 (-18)	460 (-16)

DANGER

Numbers in brackets indicate recommended minimum operating temperature in °C

THE UNIT MUST NOT RUN BELOW THIS TEMPERATURE

TABLE 5 APPROVED LUBRICANTS

Type H Polyalphaolefin based synthetic lubricants with Anti-Wear or EP additives. These have a medium to high load carrying capacity.

SUPPLIER	LUBRICANT RANGE	See Notes	GRADE NUMBERS	
			5H	6H
			-22°F to 95°F (-30°C to 35°C)	68°F to 122°F (20°C to 50°C)
Batoyle Freedom Group	Titan		220 (-31)	320 (-28)
Boxer Services Limited	Silkgear		220 (-35)	320 (-35)
BP Oil International Limited	Enersyn EPX	e		320 (-28)
Caltex	Pinnacle EP		220 (-43)	320 (-43)
Carl Bechem GmbH	Berusynth GP		220 (-38)	320 (-35)
Castrol International	Alphasyn EP	c	220 (-37)	320 (-31)
	Alphasyn T		220 (-31)	320 (-28)
Chevron International Oil Co	Tegra		220 (-46)	320 (-33)
Esso/Exxon	Spartan Synthetic EP	e	220 (-46)	320 (-43)
Fina	Giran P		220 (-30)	320 (-25)
Fuchs Lubricants (UK) Plc	Renogear SG		220 (-32)	320 (-30)
Fuchs Mineraloelwerke GmbH	Renolin Unisyn CLP		220 (-37)	320 (-34)
Klüber Lubrication	Klübersynth GEM 4		220 (-35)	320 (-35)
Kuwait Petroleum International	Q8 EL Greco		220 (-22)	320 (-19)
Lubrication Engineers Inc	Synolec Gear Lubricant		9920 (-40)	
Mobil Oil Company Limited	Mobilgear SHC		220 (-40)	320 (-37)
	Mobilgear SHC XMP	c	220 (-40)	320 (-33)
Optimol Ölwerke GmbH	Optigear Synthetic A		220 (-31)	320 (-31)
Petro-Canada	Super Gear Fluid	e	220 (-43)	320 (-37)
Shell Oils	Omala HD	c	220 (-43)	320 (-40)
Texaco Limited	Pinnacle EP		220 (-43)	320 (-33)
	Pinnacle WM	c	220 (-43)	320 (-43)
Total	Carter EP/HT		220 (-34)	320 (-31)
Tribol GmbH	Tribol 1510		220 (-36)	320 (-33)

NOTES:

- c) These lubricants have been tested for micro-pitting (FZG Type C), test results are available.
- e) These lubricants contain additives which may adversely affect silvered or white metal components; consult oil supplier.
- h) Minimum operating temperatures of these lubricants are based on worst case values, lower operating temperatures may be available, please check with local supplier.

DANGER

Numbers in brackets indicate recommended minimum operating temperature in °C

THE UNIT MUST NOT RUN BELOW THIS TEMPERATURE

SERIES G STANDARD SHAFT SEALING ARRANGEMENTS

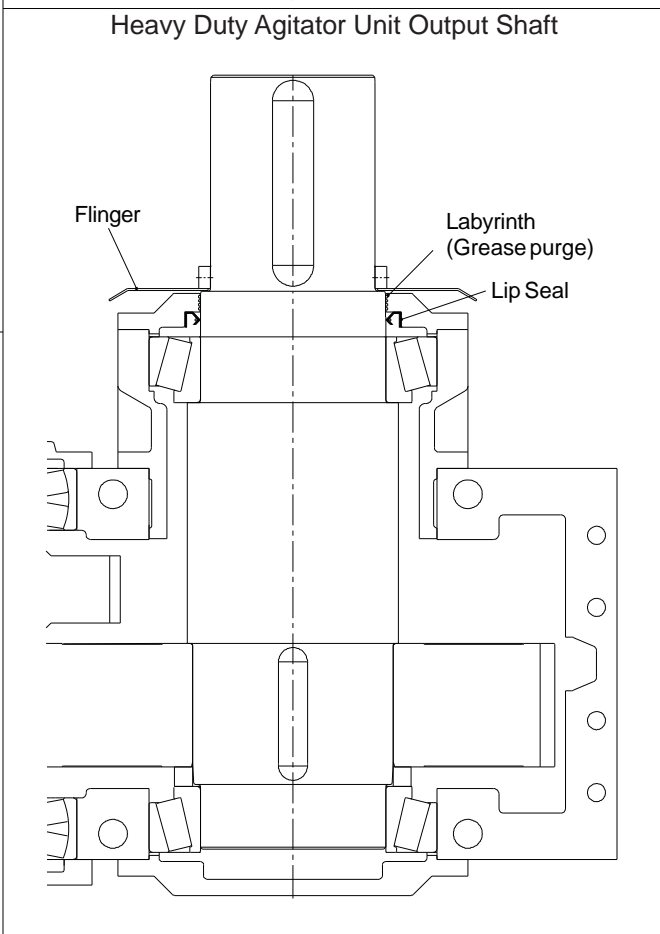
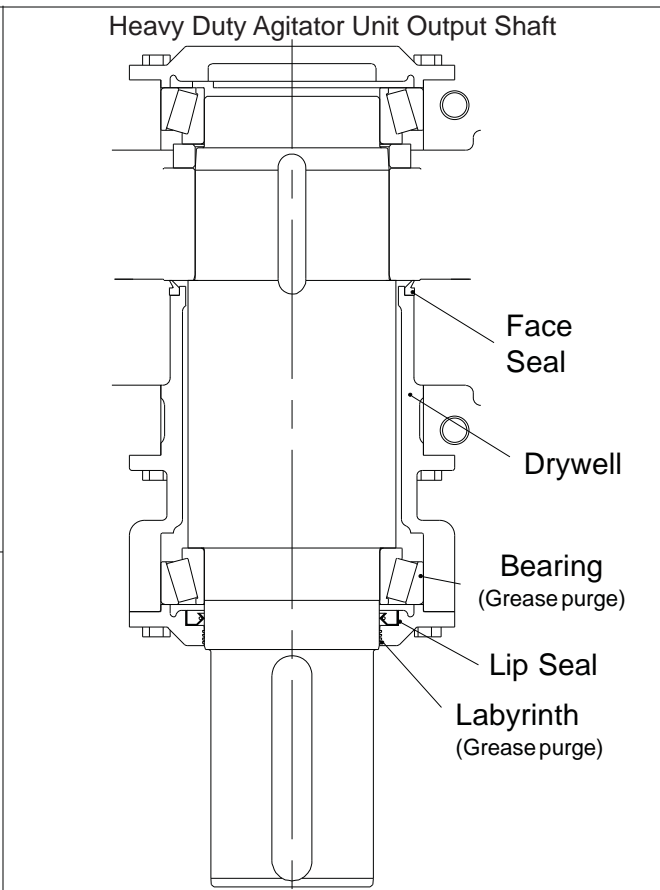
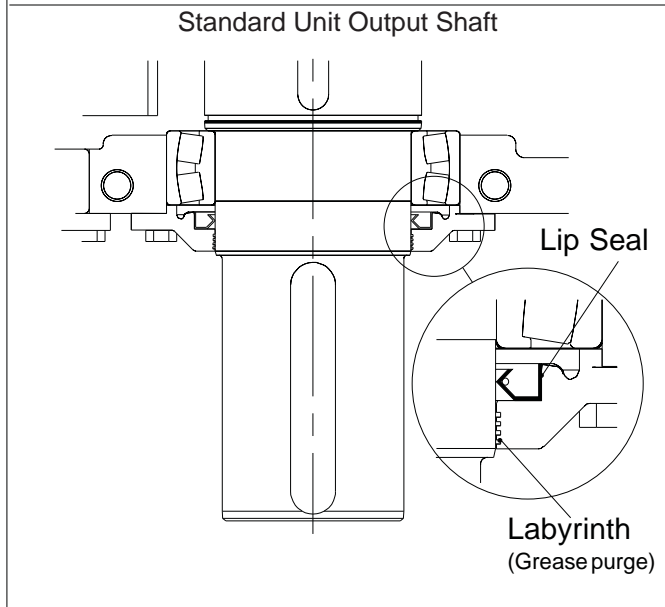
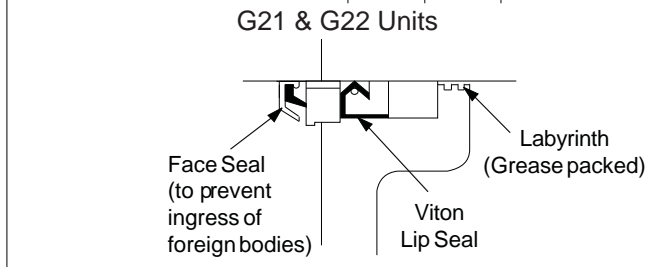
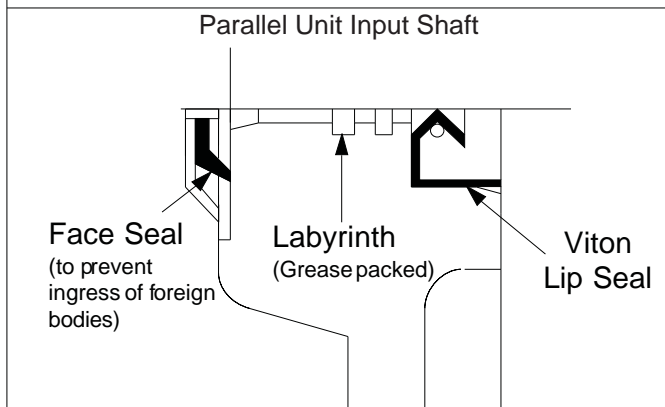
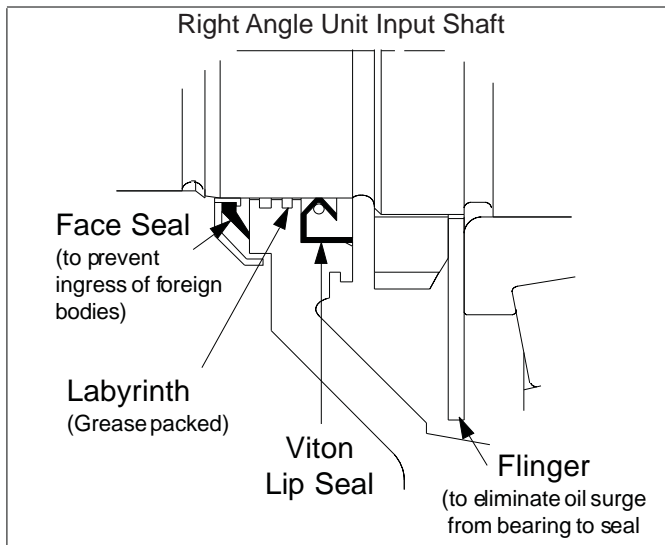

INPUT SHAFT OPTIONS

INPUT SHAFT OPTIONS

* Inch shaft has an open ended keyway, therefore no 'C' dimension is required.

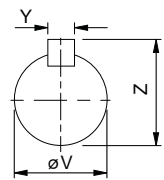
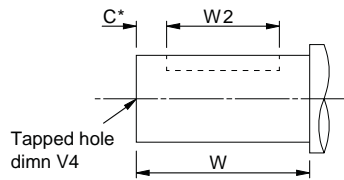

Column 11 Entry

	Inch	Metric
Single	<input type="text" value="N"/>	<input type="text" value="-"/>
Double	<input type="text" value="P"/>	<input type="text" value="D"/>

Parallel Shaft Units

SIZE OF UNIT	TYPE OF INPUT SHAFT	NO OF REDUCTIONS	DIMENSIONS IN INCHES (Metric Shaft in mm)						
			C*	øV	V4	W	W2	Y	Z
14 AND 15	Inch	2 Stage	-	1.8750" 1.8740"	5/8" UNF x 1.25 deep	5.31"	4.13"	0.500"	2.10"
		3 and 4 Stage	-	1.3750" 1.3745"	1/2" UNF x 1 deep	3.74"	3.00"	0.3125"	1.51"
16 AND 17	Inch	2 Stage	-	2.2500" 2.2490"	3/4" UNF x 1.62 deep	5.71"	4.13"	0.500"	2.47"
		3 and 4 Stage	-	1.7500" 1.7490"	5/8" UNF x 1.25 deep	4.53"	4.13"	0.375"	1.92"
18 AND 19	Inch	2 Stage	-	3.2500" 3.2490"	1" UNF x 2 deep	7.48"	5.88"	0.750"	3.58"
		3 and 4 Stage	-	2.2500" 2.2490"	3/4" UNF x 1.62 deep	5.71"	4.13"	0.500"	2.47"
21 AND 22	Inch	2 Stage	-	4.2500" 4.2490"	1" UNF x 2 deep	8.27"	7.5"	1.000"	4.69"
		3 and 4 Stage	-	3.0000" 2.9990"	3/4" UNF x 1.62 deep	7.48"	6.50"	0.750"	3.33"

14 AND 15	Metric	2 Stage	3	50.018 50.002	M16 x 36	138	130	14	53.5
		3 and 4 Stage	3	35.018 35.002	M12 x 25	99	90	10	38
16 AND 17	Metric	2 Stage	3	60.03 60.011	M20 x 43	148	140	18	64
		3 and 4 Stage	3	45.018 45.002	M16 x 36	118	110	14	48.5
18 AND 19	Metric	2 Stage	3	85.035 85.013	M24 x 52	190	180	22	90
		3 and 4 Stage	3	60.03 60.011	M20 x 43	150	140	18	64
21 AND 22	Metric	2 Stage	3	110.035 110.013	M30 x 63	210	200	28	116
		3 and 4 Stage	3	80.03 80.011	M20 x 43	190	180	22	85

Right Angle Shaft Units

SIZE OF UNIT	TYPE OF INPUT SHAFT	NO OF REDUCTIONS	DIMENSIONS IN INCHES (Metric Shaft in mm)						
			C*	øV	V4	W	W2	Y	Z
14 AND 15	Inch	3 Stage	-	1.5000" 1.4995"	5/8" UNF x 1.25 deep	3.94"	3.44"	0.375"	1.66"
16 AND 17	Inch	3 Stage	-	1.8750" 1.8740"	5/8" UNF x 1.25 deep	5.51"	4.13"	0.500"	2.10"
		4 Stage	-	1.5000" 1.4995"	5/8" UNF x 1.25 deep	3.94"	3.44"	0.375"	1.66"
18 AND 19	Inch	3 Stage	-	3.0000" 2.9990"	3/4" UNF x 1.62 deep	6.30"	5.25"	0.750"	3.33"
		4 Stage	-	1.8750" 1.8740"	5/8" UNF x 1.25 deep	5.51"	4.13"	0.500"	2.10"
21 AND 22	Inch	3 Stage	-	4.0000" 3.9990"	1" UNF x 2 deep	8.27"	7.5"	1.00"	4.44"
		4 Stage	-	3.0000" 2.9990"	3/4" UNF x 1.62 deep	6.30"	5.25"	0.750"	3.33"

14 AND 15	Metric	3 Stage	3	38.018 38.002	M12 x 32	100	90	10	41
16 AND 17	Metric	3 Stage	3	50.018 50.002	M16 x 36	140	130	14	53.5
		4 Stage	3	38.018 38.002	M12 x 32	100	90	10	41
18 AND 19	Metric	3 Stage	3	75.03 75.011	M20 x 43	160	150	20	79.5
		4 Stage	3	50.018 50.002	M16 x 36	140	130	14	53.5
21 AND 22	Metric	3 Stage	3	100.035 100.013	M24 x 52	210	200	28	106
		4 Stage	3	75.03 75.011	M20 x 43	160	150	20	79.5

OUTPUT SHAFT OPTIONS

OUTPUT SHAFT OPTIONS

* Inch shaft has an open ended keyway, therefore no 'C' dimension is required.

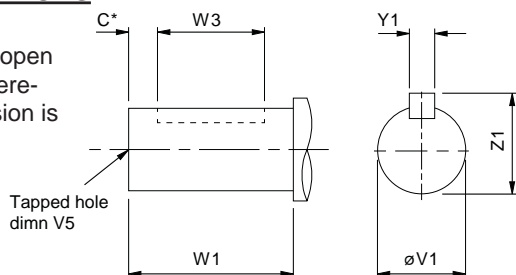

Column 10 Entry

Inch

Single L

Double R

Agitator S

or T

Column 10 Entry

Metric

Single F

Double G

Agitator A

or C

SIZE OF UNIT	TYPE OF OUTPUT SHAFT	DIMENSIONS IN MM (Inch Shaft in Inches)						
		C*	ØV1	V5	W1	W3	Y1	Z1
14	Inch Single	-	4.500"	1" UNF x 2" deep	7.09"	6.50"	1.00"	4.94"
	Inch Double							
	Inch Agitator							
15	Inch Single	-	5.000"	1" UNF x 2" deep	7.48"	7.13"	1.25"	5.55"
	Inch Double							
	Inch Agitator							
16	Inch Single	-	6.000"	1.25" UNF x 2.5" deep	9.06"	8.75"	1.50"	6.66"
	Inch Double							
	Inch Agitator							
17	Inch Single	-	6.750"	1.25" UNF x 2.5" deep	9.84"	9.38"	1.75"	7.39"
	Inch Double							
	Inch Agitator							
18	Inch Single	-	7.500"	1.5" UNF x 3 deep	11.81"	11.38"	1.75"	8.15"
	Inch Double							
	Inch Agitator							
19	Inch Single	-	8.250"	1.5" UNF x 3 deep	13.78"	13.00"	2.00"	8.88"
	Inch Double							
	Inch Agitator							
21	Inch Single	-	8.500"	1.5" UNF x 3 deep	13.78"	13.00"	2.00"	9.13"
	Inch Double							
	Inch Agitator							
22	Inch Single	-	9.250"	1.5" UNF x 3 deep	14.96"	14.25"	2.5"	9.95"
	Inch Double							
	Inch Agitator							

14	Metric Single	5	110.035	M30 x 3.5 63 deep	180	170	28	116
	Metric Double							
	Metric Agitator							
15	Metric Single	5	130.04	M30 x 3.5 63 deep	190	180	32	137
	Metric Double							
	Metric Agitator							
16	Metric Single	5	145.04	M42 x 4.5 81 deep	230	220	36	153
	Metric Double							
	Metric Agitator							
17	Metric Single	5	170.04	M42 x 4.5 81 deep	250	240	40	179
	Metric Double							
	Metric Agitator							
18	Metric Single	5	190.046	M42 x 4.5 81 deep	300	290	45	200
	Metric Double							
	Metric Agitator							
19	Metric Single	5	210.046	M42 x 4.5 81 deep	350	340	50	221
	Metric Double							
	Metric Agitator							
21	Metric Single	5	220.046	M42 x 4.5 81 deep	350	340	50	231
	Metric Double							
	Metric Agitator							
22	Metric Single	5	240.046	M42 x 4.5 81 deep	380	340	56	252
	Metric Double							
	Metric Agitator							

OUTPUT BORE OPTIONS

OUTPUT BORE OPTIONS

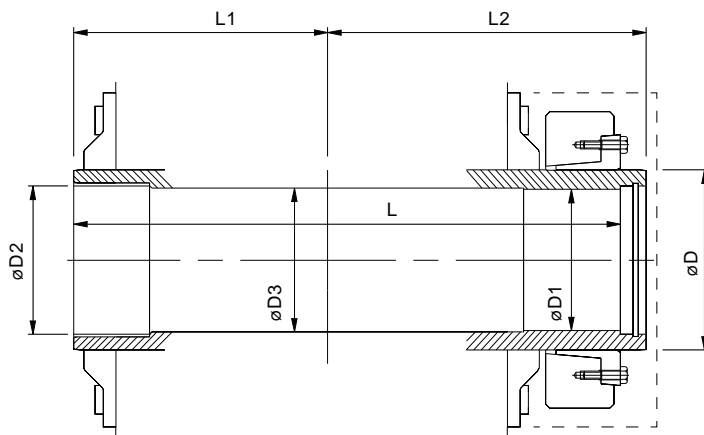

Column 10 Entry *

With Shrink Disc J

SIZE OF UNIT	TYPE OF OUTPUT BORE	DIMENSIONS IN INCHES						
		ØD	ØD1	ØD2	ØD3	L	L1	L2
14	Standard with Shrink Disc	4.72	3.742	3.940	3.78	16.34	7.09	10.04
			3.740	3.937				
15	Standard with Shrink Disc	5.51	4.332	4.531	4.37	16.54	7.09	10.24
			4.331	4.528				
16	Standard with Shrink Disc	6.30	4.923	5.122	4.96	20.98	9.06	12.80
			4.921	5.118				
17	Standard with Shrink Disc	7.09	5.710	5.909	5.79	21.57	9.06	13.39
			5.709	5.906				
18	Standard with Shrink Disc	7.87	6.301	6.697	6.38	27.09	11.81	16.14
			6.299	6.693				
19	Standard with Shrink Disc	8.66	6.694	7.091	6.77	27.87	11.81	16.93
			6.693	7.087				
21	Standard with Shrink Disc	10.24	8.270	8.665	8.35	32.44	13.78	19.69
			8.268	8.661				
22	Standard with Shrink Disc	11.02	9.057	9.453	9.13	33.03	13.78	20.28
			9.055	9.449				

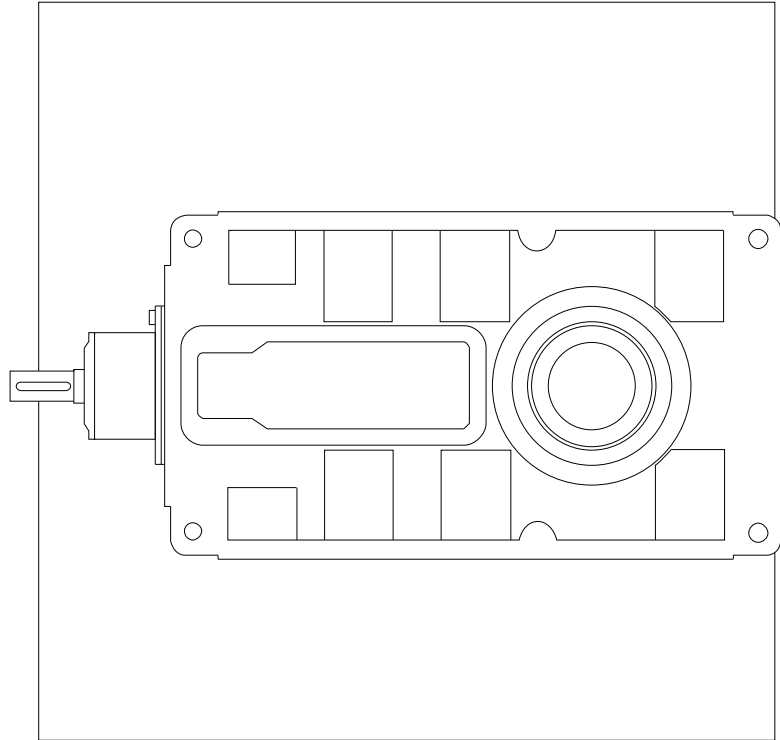

REDUCER
SERIES G

SERIES G OVERHUNG & AXIAL LOADS ON SHAFTS

Maximum permissible overhung loads

When a sprocket, gear etc. is mounted on the shaft a calculation, as below, must be made to determine the overhung load on the shaft, and the results compared to the maximum permissible overhung loads tabulated. Overhung loads can be reduced by increasing the diameter of the sprocket, gear, etc. If the maximum permissible overhung load is exceeded, the sprocket, gear, etc. should be mounted on a separate shaft, flexibly coupled and supported in its own bearings, or the gear unit shaft should be extended to run in an outboard bearing. Alternatively, a larger gear is often a less expensive solution.

Permissible overhung loads vary according to the direction of rotation. The values tabulated are for the most unfavourable direction with the unit transmitting full rated power and the load P applied midway along the shaft extension. Hence they can sometimes be increased for a more favourable direction of rotation, or if the power transmitted is less than the rated capacity of the gear unit, or if the load is applied nearer to the gear unit case. Refer to our Application Engineers for further details. In any event, the sprocket, gear etc. should be positioned as close as possible to the gear unit case in order to reduce bearing loads and shaft stresses, and to prolong life.

All units will accept 100% momentary overload on stated capacities.

Overhung load (lb's)

$$P = \frac{Hp \times 126\,000 \times K}{N \times D}$$

where

- P = equivalent overhung load (lb's)
 Hp = power transmitted by the shaft (Hp)
 N = speed of shaft (rev/min)
 D = pitch diameter of sprocket, etc. (in)
 K = factor

Overhung member K (factor)

Chain sprocket*	1.00
Spur or helical pinion	1.25
Vee belt sheave	1.50
Flat belt pulley	2.00

* If multistrand chain drives are equally loaded and the outer strand is further than dimension A output or B input, refer to our Application Engineers.

Note: 1 lb = 0.4536 kg = 4.4484 newtons.

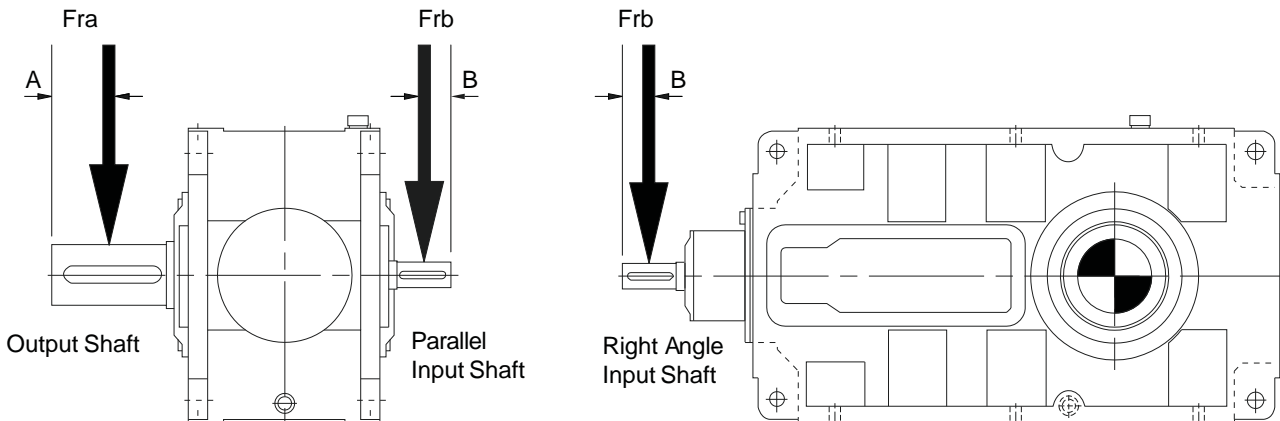

Output Shaft - Distance 'A'

(midway along the shaft extension)

Size of unit	Dimension A (Inches)
G14	3.55"
G15	3.74"
G16	4.53"
G17	4.92"
G18	5.91"
G19	6.89"
G21	6.89"
G22	7.48"

Input Shaft - Distance 'B'

(midway along the shaft extension)

Size of unit	Parallel Shaft Unit		Right Angle Shaft Unit	
	2 Stage	3 & 4 Stage	3 Stage	4 Stage
G14 and G15	2.66	1.87	1.97	-
G16 and G17	2.86	2.27	2.76	1.97
G18 and G19	3.74	2.86	3.15	2.76
G21 and G22	4.13	3.74	4.13	3.15

Axial Thrust Capacities (lb's)

Permissible axial thrust capacities vary according to the direction of rotation and the direction of thrust, towards or away from the unit. The values tabulated are for the most unfavourable direction and hence can sometimes be increased. Similarly they can sometimes be increased if the power transmitted is less than the rated capacity of the gear unit.

Thrust capacities tabulated refer to output shaft, and are calculated without any overhung loads being applied. In cases where combined axial thrusts and overhung loads are to be applied, refer to our Application Engineers.

SERIES G

OVERHUNG & AXIAL LOADS ON SHAFTS

OVERHUNG LOADS (Fra) ON OUTPUT SHAFT (lb-force)

Parallel Shaft Units Handings: LR, RL, DL and DR
Right Angle Shaft Units All handings with preferred shaft rotations

Shaft Speed (Rev/min)	Unit Size							
	14	15	16	17	18	19	21	22
< 240	5620	8990	9670	18430	19110	26080	29230	35970
< 180	6070	9670	10340	18430	19560	26080	29230	35970
< 130	6520	10570	11020	18430	20230	26080	29230	35970
< 90	7190	11240	11240	18430	21360	26080	29230	35970
< 45	7640	12360	12360	18430	24730	26080	44290	44290
< 20	6740	12360	12360	18430	26080	26080	61820	61820

OVERHUNG LOADS (Fra) ON OUTPUT SHAFT (lb-force)

Parallel Shaft Units Handings: LL and RR
Right Angle Shaft Units All handings with non-preferred shaft rotations

Shaft Speed (Rev/min)	Unit Size							
	14	15	16	17	18	19	21	22
< 240	5620	7190	6290	13490	13490	17980	17980	17980
< 180	6070	7870	6520	13490	13710	17980	17980	17980
< 130	6520	8320	6970	13490	14160	17980	17980	17980
< 90	7190	8990	6970	13490	15290	17980	17980	17980
< 45	7640	10120	6970	13490	17980	17980	29230	29230
< 20	6970	10120	6970	13490	17980	17980	56200	56200

AXIAL THRUST ON OUTPUT SHAFT (lb-force)

Shaft Speed (Rev/min)	Unit Size							
	14	15	16	17	18	19	21	22
< 240	1120	1910	1800	5620	3600	5850	5850	8090
< 180	1150	1930	1910	5620	3820	6070	6070	8090
< 130	1190	2230	2140	6070	4050	6740	6070	8090
< 90	1390	2700	2250	6520	4270	7640	6070	8090
< 45	2470	4500	3370	8990	8090	10120	8320	8320
< 20	4270	7190	5620	14610	14610	14610	17980	19560

OVERHUNG LOADS (Frb) ON INPUT SHAFT (lb-force)

Unit Type		Unit Size							
		14	15	16	17	18	19	21	22
Parallel Shaft	2 Stage	3370	3370	4950	4950	8770	8770	15740	15740
	3 and 4 Stage	1550	1550	2050	2050	3600	3600	5620	5620
Right Angle	2 Stage	2470	2470	3600	3600	9220	9220	12590	12590
	3 and 4 Stage	-	-	2470	2470	3600	3600	9220	9220

SERIES G AGITATOR APPLICATIONS BENDING MOMENT CAPACITY

To calculate the Bending Moment on the gearbox output shaft using the method recommended in The Engineering Equipment Users' Association Handbook No. 9:-

$$\text{Bending Moment (lb.in)} = \frac{\text{Absorbed Power (hp)} \times 63000 \times L}{\text{Shaft Speed} \times 0.75 R}$$

The above information is given for guidance. When more precise bending moment values are available they should be used.

Check the Bending Moment Capacity of the Gearbox
Agitator units are suitable for supporting a paddle directly coupled to the gearbox output shaft and for accepting the bending moments and axial thrusts generated from the forces at the paddle. Agitator type units have an extended bearing span and taper bearings to accept higher loads than the standard unit.

Check the Bending Moment Capacity limited by shaft stress, using Table 2.

Check the Bending Moment Capacity limited by bearing life, using Table 3.

Note: Bearing Capacities are based on 10,000 hours, L10 life.
For other bearing lives multiply the values in Table 3 by the factors in Table 1.

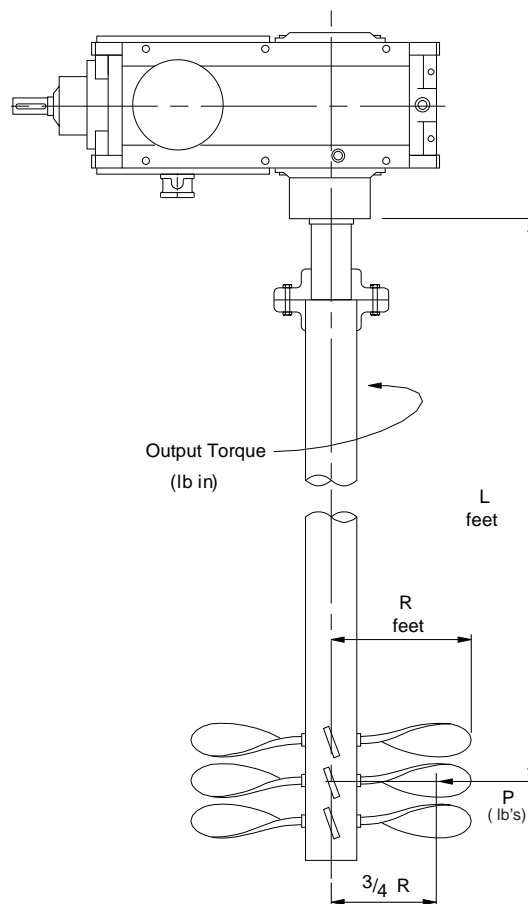

Table 1 Bearing Life Factors (F_B)

Factor	Required Life (hours)				
	5000	10000	25000	50000	100000
	1.23	1	0.76	0.62	0.50
For intermediate values					
$F_B = \left(\frac{10000}{\text{Required Life (hours)}} \right)^{0.3}$					

Table 2 Bending Moment Capacity (lb-force)

Allowable Bending Moment at output shaft lower bearing, limited by SHAFT STRESS

Unit Type	Unit Size							
	14	15	16	17	18	19	21	22
Agitator Units	99130	153120	214190	330130	442540	601850	902780	**

Table 3 Bending Moment Capacity (lb-force)

Allowable Bending Moment on output shaft bearings, limited by BEARING LIFE (10,000 hrs L10)*

Unit Type	Output Speed rev/min	Unit Size							
		14	15	16	17	18	19	21	22
Agitator Units	< 240	52220	96470	101780	227460	238090	325710	354030	**
	< 180	65500	114170	128340	266410	298270	398280	469090	
	< 130	93820	148690	187640	344290	431920	539900	743460	
	< 90	101780	162850	202680	377040	469090	601850	805420	
	< 45	146920	223040	294730	486790	646110	787720	1177150	
	< 20	213300	291190	413330	628400	858520	1035540	1557730	

* For other lives multiply values by the factors in table 1

** Consult Application Engineering

SERIES G AGITATOR APPLICATIONS AXIAL THRUST LOADS

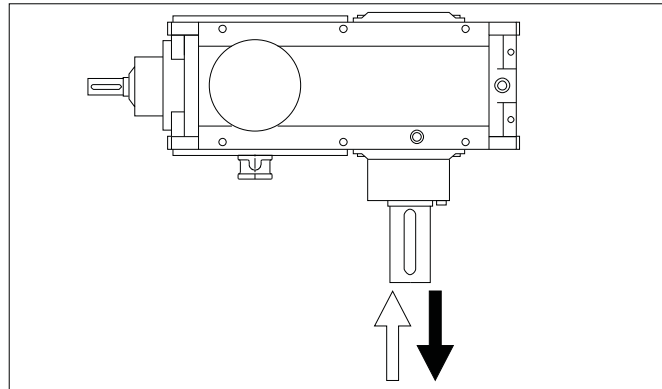

Table 4 Axial thrust capacity (lb-force)

Allowable thrust on output shaft, limited by COVER BOLT STRESS

Unit Type	Unit Size							
	14	15	16	17	18	19	21	22
Agitator Units	6740	8990	12360	14610	14610	14610	33720	**

Note: The values in table 4 are calculated for the most adverse direction of rotation. For the opposite rotation they can be increased. Consult our Application Engineers for an analysis where necessary.

Table 5 Axial thrust capacity (lb-force)

Allowable thrust on output shaft, limited by BEARING LIFE (10,000 hrs L10)*

Direction Of Thrust	Unit Type	Output Speed rev/min	Unit Size							
			14	15	16	17	18	19	21	22
↑	Agitator Units	< 240	3150	5850	5170	11470	8990	12360	12590	**
		< 180	3150	6070	5400	11690	9220	12590	13040	
		< 130	3370	5850	5620	11690	9220	12810	13040	
		< 90	3600	6740	6290	12810	10340	14160	14840	
		< 45	5850	9670	10120	18210	16860	21810	24730	
		< 20	8990	14160	15740	26080	25850	32820	39340	
↓	Agitator Units	< 240	2250	4950	3820	9890	6970	10120	8990	**
		< 180	2470	5170	4050	10120	7190	10120	9220	
		< 130	2470	5400	4050	10340	7190	10570	9220	
		< 90	2920	5620	4720	11240	8320	11910	11240	
		< 45	5170	8770	8540	16640	14610	19330	20910	
		< 20	8090	12590	14390	24730	23830	30350	35300	

* For other lives multiply values by the factors in table 1 page 30.

** Consult Application Engineering

Note: Values are based on the most unfavourable directions of rotation. Higher values may be permitted after analysis by our Application Engineers.

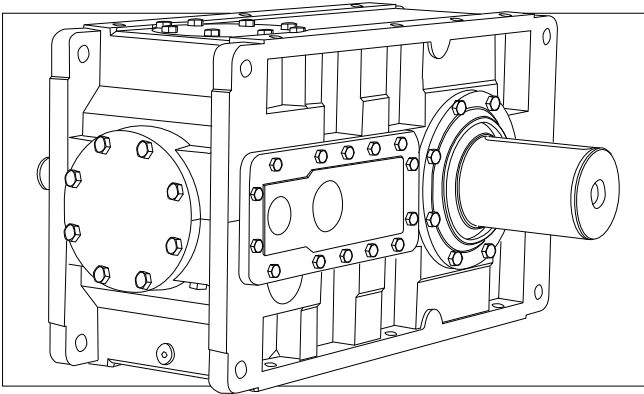

PARALLEL SHAFT UNITS

<u>Contents</u>	<u>Page No</u>
Moments of Inertia _____	34
Exact Ratios _____	35
Mechanical Ratings - Input Power / Output Torque _____	36 - 39
Thermal Ratings _____	40
Dimension Sheets - Speed Reducers _____	41 - 45

SERIES G

MOMENTS OF INERTIA

PARALLEL SHAFT UNITS

MOMENTS OF INERTIA (lb in²) Referred to Input Shaft

PARALLEL SHAFT UNITS - without fans

NOMINAL RATIO COLUMN ENTRY	PARALLEL SHAFT UNITS - SIZE								
	G14	G15	G16	G17	G18	G19	G21	G22	
6.3	140	-	486	-	2281	-	-	-	DOUBLE REDUCTION
7.1	115	-	451	-	1970	-	7866	-	
8.0	101	166	390	604	1589	2722	6840	8615	
9.0	87	135	333	554	1371	2346	5985	7490	
10.	78	118	286	479	1277	1878	5198	6430	
11.	68	103	239	398	1105	1602	4412	5609	
12.	58	89	200	337	855	1474	3865	4754	
14.	50	75	166	282	799	1260	3280	4104	
16.	43	65	152	236	665	978	2753	3488	
18.	36	56	142	193	592	893	2562	2900	
20.	34	46	130	173	569	735	2267	2688	TRIPLE REDUCTION
22.	31	39	120	157	523	653	2097	2363	
25.	29	36	109	144	460	619	1932	2175	
28.	27	33	101	130	446	564	1801	1994	
32.	25	30	100	118	410	489	1688	1847	
36.	15	28	51	108	209	470	1630	1724	
40.	13	26	48	106	203	428	819	1659	
45.	13	15	45	56	192	224	776	845	
50.	12	14	43	51	176	215	735	797	
56.	12	13	41	48	173	202	701	749	
63.	11	13	40	46	162	183	674	715	QUADRUPLE REDUCTION
71.	11	12	38	43	149	178	658	681	
80.	11	12	37	42	147	168	571	667	
90.	10	11	37	39	142	152	556	624	
100	10	11	31	38	125	149	547	58	
112	10	11	31	38	123	145	445	599	
125	10	10	31	32	120	125	438	496	
140	6	10	19	31	86	123	434	486	
160	6	10	18	31	77	121	287	482	
180	6	6	18	21	75	86	250	328	
200	6	6	18	18	75	77	246	287	
225	-	6	-	18	-	75	245	286	
250	-	6	-	18	-	75	-	284	

PARALLEL SHAFT UNITS - with fans

If fan cooling is required the inertia of the fan must be added to the table above.

MOMENTS OF INERTIA of fans (lb in²)

	G14/G15	G16/G17	G18/G19	G21
DOUBLE REDUCTION	97	253	808	1676
TRIPLE REDUCTION	N/A	97	253	808

GD² (lb in²) = 4 x Moment of Inertia (lb in²)

SERIES G EXACT RATIOS PARALLEL SHAFT UNITS

EXACT RATIOS - PARALLEL SHAFT UNITS

Double Reduction

Nominal Ratio Column Entry	UNIT - SIZE							
	G14	G15	G16	G17	G18	G19	G21	G22
6 7 8								
6 . 3	6.1	-	6.528	-	6.324	-	-	-
7 . 1	7.029	-	7.06	-	6.986	-	7.36	-
8 . 0	7.752	7.7	7.729	8.393	8.016	7.93	8.153	8.221
9 . 0	8.578	8.873	8.82	9.078	8.935	8.76	9.221	9.106
1 0 .	9.531	9.785	9.929	9.938	9.765	10.051	10.104	10.293
1 1 .	10.643	10.828	11.063	11.34	10.957	11.204	11.324	11.285
1 2 .	11.957	12.031	12.641	12.766	12.797	12.245	12.765	12.647
1 4 .	13.534	13.435	14.36	14.223	14.092	13.739	14.494	14.257
1 6 .	15.462	15.094	15.504	16.253	15.982	16.047	16.608	16.188
1 8 .	-	17.084	-	18.463	-	17.671	17.851	18.549
2 0 .	-	19.517	-	19.934	-	20.04	-	19.938

Triple Reduction

Nominal Ratio Column Entry	UNIT - SIZE							
	G14	G15	G16	G17	G18	G19	G21	G22
6 7 8								
1 8 .	17.401	-	17.934	-	17.539	-	-	-
2 0 .	19.335	-	20.19	-	19.168	-	20.569	-
2 2 .	21.591	21.966	22.494	23.058	21.507	21.994	23.051	22.973
2 5 .	24.256	24.406	25.704	25.958	25.12	24.036	25.985	25.746
2 8 .	27.455	27.254	29.199	28.921	27.662	26.969	29.506	29.023
3 2 .	31.365	30.619	31.525	33.048	31.371	31.499	33.809	32.955
3 6 .	34.721	34.657	35.77	37.542	35.182	34.688	36.34	37.761
4 0 .	38.579	39.592	40.269	40.532	38.45	39.339	41.011	40.587
4 5 .	43.08	43.828	44.865	45.99	43.141	44.117	45.96	45.804
5 0 .	48.399	48.698	51.268	51.774	50.388	48.215	51.81	51.332
5 6 .	54.782	54.379	58.239	57.683	55.488	54.098	58.829	57.865
6 3 .	62.583	61.094	62.877	65.916	62.928	63.185	67.408	65.705
7 1 .	-	69.151	-	74.879	-	69.58	72.455	75.287
8 0 .	-	78.999	-	80.842	-	78.909	-	80.924

Quadruple Reduction

Nominal Ratio Column Entry	UNIT - SIZE							
	G14	G15	G16	G17	G18	G19	G21	G22
6 7 8								
7 1 .	70.494	-	71.59	-	73.105	-	-	-
8 0 .	78.327	-	81.324	-	80.504	-	79.169	-
9 0 .	87.465	88.984	87.8	92.044	91.298	91.671	90.715	88.423
1 0 0	98.265	98.872	104.001	104.559	102.455	100.949	97.506	101.318
1 1 2	111.224	110.407	118.142	112.886	112.825	114.485	115.479	108.903
1 2 5	127.063	124.039	127.55	133.716	127.953	128.475	132.32	128.977
1 4 0	136.419	140.398	140.233	151.897	140.825	141.479	142.226	147.786
1 6 0	153.263	160.392	166.109	163.993	158.034	160.449	159.476	158.85
1 8 0	173.476	172.201	188.694	180.299	174.029	176.59	188.872	178.116
2 0 0	198.181	193.464	203.721	213.568	197.364	198.17	216.416	210.948
2 2 5	-	218.978	-	242.607	-	218.227	232.618	241.712
2 5 0	-	250.163	-	261.927	-	247.488	-	259.808

SERIES G

PARALLEL SHAFT UNIT MECHANICAL RATINGS AT 1750 RPM INPUT

Nominal Ratio Column Entry	Nominal Output Speed RPM	Mechanical Capacity	PARALLEL SHAFT UNITS - SIZE								
			G14	G15	G16	G17	G18	G19	G21	G22	
6.3	278	Input power - HP	386	-	739	-	1676	-	-	-	
		Output torque - lb-in	82566	-	169027	-	374336	-	-	-	
7.1	246	Input power - HP	349	-	716	-	1569	-	3017	-	
		Output torque - lb-in	85664	-	176991	-	388496	-	787611	-	
8.0	219	Input power - HP	325	390	666	739	1421	1676	3017	3017	
		Output torque - lb-in	87876	105310	180531	217699	401770	469027	867257	878761	
9.0	194	Input power - HP	300	351	618	716	1322	1569	3017	3017	
		Output torque - lb-in	90265	108850	191150	228319	415929	486726	973451	973451	
10	175	Input power - HP	276	327	569	666	1274	1421	2883	3017	
		Output torque - lb-in	92035	112389	197345	231858	438053	504425	1026549	1097345	
11	159	Input power - HP	251	304	519	618	1173	1322	2655	2883	
		Output torque - lb-in	92920	115044	200885	245133	451327	522124	1053097	1150442	
12	146	Input power - HP	227	279	493	569	1021	1274	2434	2655	
		Output torque - lb-in	94690	116814	216814	253982	457522	549558	1088496	1185841	
14	125	Input power - HP	202	253	421	519	971	1173	2186	2441	
		Output torque - lb-in	95575	118584	210619	258407	478761	566372	1106195	1230088	
16	109	Input power - HP	181	228	396	499	869	1021	1971	2186	
		Output torque - lb-in	97345	120354	214159	282301	484956	574336	1150442	1247788	
18	97.2	Input power - HP	156	205	319	421	764	971	1824	2025	
		Output torque - lb-in	93805	120354	198230	270796	466372	600885	1150442	1318584	
20	87.5	Input power - HP	145	182	307	396	764	869	1589	1918	
		Output torque - lb-in	97345	123894	214159	275221	508850	608850	1150442	1345133	
22	79.5	Input power - HP	131	156	282	319	687	764	1421	1609	
		Output torque - lb-in	97345	117699	218584	254867	512389	584956	1150442	1300885	
25	70.0	Input power - HP	118	143	256	319	597	764	1262	1582	
		Output torque - lb-in	97345	121239	226549	286726	518584	638938	1150442	1424779	
28	62.5	Input power - HP	105	130	225	308	543	687	1113	1408	
		Output torque - lb-in	97345	122124	226549	308850	518584	679646	1150442	1424779	
32	54.7	Input power - HP	92.8	116	209	274	479	642	974	1242	
		Output torque - lb-in	97345	123009	226549	311504	518584	700000	1150442	1424779	
36	48.6	Input power - HP	80.2	104	184	241	409	583	907	1086	
		Output torque - lb-in	97345	123894	226549	312389	518584	700000	1150442	1424779	
40	43.8	Input power - HP	73.0	91.7	164	224	392	515	805	1012	
		Output torque - lb-in	97345	123894	226549	313274	518584	700885	1150442	1424779	
45	38.9	Input power - HP	66.0	79.3	148	192	350	409	719	898	
		Output torque - lb-in	97345	119469	226549	304425	518584	620354	1150442	1424779	
50	35.0	Input power - HP	59.3	72.0	129	173	299	409	638	803	
		Output torque - lb-in	96460	121239	226549	307080	518584	677876	1150442	1424779	
56	31.3	Input power - HP	52.8	65.2	113	156	272	377	563	713	
		Output torque - lb-in	97345	122124	226549	308850	518584	700885	1150442	1424779	
63	27.8	Input power - HP	46.7	58.5	105	138	240	323	492	630	
		Output torque - lb-in	97345	123894	226549	311504	518584	700885	1150442	1424779	
71	24.6	Input power - HP	39.4	52.2	93.1	121	184	294	459	551	
		Output torque - lb-in	94690	123894	226549	312389	455752	700885	1150442	1424779	
80	21.9	Input power - HP	35.8	46.1	82.1	113	173	259	422	512	
		Output torque - lb-in	95575	123894	226549	313274	471681	700885	1150442	1424779	
90	19.4	Input power - HP	32.3	38.5	76.0	94.5	158	205	369	472	
		Output torque - lb-in	96460	117699	226549	296460	492035	640708	1150442	1433628	
100	17.5	Input power - HP	29.1	34.6	64.2	84.1	145	193	343	413	
		Output torque - lb-in	97345	118584	226549	299115	504425	665487	1150442	1433628	
112	15.6	Input power - HP	25.9	31.1	56.6	79.1	135	178	291	385	
		Output torque - lb-in	97345	120354	226549	303540	518584	693805	1150442	1433628	
125	14.0	Input power - HP	22.9	27.6	52.6	66.6	120	161	255	326	
		Output torque - lb-in	97345	122124	226549	302655	518584	701770	1150442	1433628	
140	12.5	Input power - HP	20.8	24.5	47.7	58.7	109	146	237	284	
		Output torque - lb-in	97345	123894	226549	302655	518584	701770	1150442	1433628	
160	10.9	Input power - HP	18.6	21.5	40.4	54.6	97.0	129	212	266	
		Output torque - lb-in	97345	123894	226549	303540	518584	701770	1150442	1433628	
180	9.72	Input power - HP	16.6	20.0	35.5	49.6	88.1	117	178	237	
		Output torque - lb-in	97345	123894	226549	303540	518584	701770	1150442	1433628	
200	8.75	Input power - HP	14.6	17.7	33.0	41.8	77.8	105	156	200	
		Output torque - lb-in	97345	123894	226549	302655	518584	701770	1150442	1433628	
225	7.78	Input power - HP	-	15.7	-	36.7	-	95.1	145	174	
		Output torque - lb-in	-	123894	-	302655	-	701770	1150442	1433628	
250	7.00	Input power - HP	-	13.8	-	34.2	-	83.9	-	162	
		Output torque - lb-in	-	123894	-	302655	-	701770	-	1433628	

DOUBLE REDUCTION

TRIPLE REDUCTION

QUADRUPLE REDUCTION

Bold Text: Forced lubrication System Required

SERIES G

PARALLEL SHAFT UNIT MECHANICAL RATINGS AT 1450 RPM INPUT

Nominal Ratio Column Entry	Nominal Output Speed RPM	Mechanical Capacity	PARALLEL SHAFT UNITS - SIZE								
			G14	G15	G16	G17	G18	G19	G21	G22	
6.3	230	Input power - HP	339	-	648	-	1462	-	-	-	DOUBLE REDUCTION
		Output torque - lb-in	87345	-	178761	-	395575	-	-	-	
7.1	204	Input power - HP	306	-	628	-	1381	-	2494	-	
		Output torque - lb-in	90265	-	187611	-	410619	-	787611	-	
8.0	181	Input power - HP	282	342	583	648	1247	1462	2494	2494	
		Output torque - lb-in	92035	111504	191150	230088	424779	496460	867257	878761	
9.0	161	Input power - HP	257	308	542	628	1160	1381	2494	2494	
		Output torque - lb-in	92920	115929	201770	240708	439823	515044	973451	973451	
10	145	Input power - HP	235	286	499	583	1117	1247	2494	2494	
		Output torque - lb-in	93805	117699	208850	245133	462832	532743	1079646	1097345	
11	132	Input power - HP	213	260	455	542	1029	1160	2360	2494	
		Output torque - lb-in	95575	119469	212389	259292	476991	551327	1141593	1203540	
12	121	Input power - HP	192	237	420	499	894	1117	2105	2333	
		Output torque - lb-in	96460	120354	223009	269027	484071	580531	1150442	1256637	
14	104	Input power - HP	173	215	369	455	852	1029	1851	2132	
		Output torque - lb-in	97345	122124	223009	272566	506195	598230	1150442	1300885	
16	90.6	Input power - HP	154	193	347	429	762	894	1623	1918	
		Output torque - lb-in	97345	123009	226549	293805	513274	607080	1150442	1318584	
18	80.6	Input power - HP	130	173	280	369	671	852	1515	1743	
		Output torque - lb-in	93805	123894	209735	286726	492920	635398	1150442	1371681	
20	72.5	Input power - HP	120	153	270	347	646	762	1320	1636	
		Output torque - lb-in	97345	123894	226549	291150	518584	643363	1150442	1380531	
22	65.9	Input power - HP	109	130	241	280	577	671	1179	1395	
		Output torque - lb-in	97345	118584	226549	269027	518584	619469	1150442	1345133	
25	58.0	Input power - HP	97.6	119	212	280	495	671	1046	1314	
		Output torque - lb-in	97345	121239	226549	303540	518584	675221	1150442	1424779	
28	51.8	Input power - HP	87.0	107	186	256	449	602	924	1168	
		Output torque - lb-in	97345	122124	226549	308850	518584	679646	1150442	1424779	
32	45.3	Input power - HP	76.8	96.4	173	227	397	532	807	1031	
		Output torque - lb-in	97345	123009	226549	311504	518584	700000	1150442	1424779	
36	40.3	Input power - HP	66.4	86.0	153	200	355	484	752	901	
		Output torque - lb-in	97345	123894	226549	312389	518584	700000	1150442	1424779	
40	36.3	Input power - HP	60.3	75.9	135	186	325	428	668	841	
		Output torque - lb-in	97345	123894	226549	313274	518584	700885	1150442	1424779	
45	32.2	Input power - HP	54.6	65.6	122	160	290	358	597	747	
		Output torque - lb-in	97345	119469	226549	304425	518584	656637	1150442	1424779	
50	29.0	Input power - HP	49.1	59.7	107	143	248	350	530	666	
		Output torque - lb-in	97345	121239	226549	307080	518584	700885	1150442	1424779	
56	25.9	Input power - HP	43.7	53.9	94	129	225	312	468	593	
		Output torque - lb-in	97345	122124	226549	308850	518584	700885	1150442	1424779	
63	23.0	Input power - HP	38.6	48.4	87	114	198	268	408	523	
		Output torque - lb-in	97345	123894	226549	311504	518584	700885	1150442	1424779	
71	20.4	Input power - HP	32.6	43.2	77	101	161	243	380	457	
		Output torque - lb-in	94690	123894	226549	312389	482301	700885	1150442	1424779	
80	18.1	Input power - HP	29.6	38.2	68	93.6	152	215	350	425	
		Output torque - lb-in	95575	123894	226549	313274	499115	700885	1150442	1433628	
90	16.1	Input power - HP	26.8	31.9	63	79.9	138	180	306	392	
		Output torque - lb-in	96460	117699	226549	302655	518584	677876	1150442	1433628	
100	14.5	Input power - HP	24.0	28.7	53	70.4	124	169	286	343	
		Output torque - lb-in	97345	118584	226549	302655	518584	701770	1150442	1433628	
112	12.9	Input power - HP	21.5	25.7	47	65.4	112	149	241	319	
		Output torque - lb-in	97345	120354	226549	302655	518584	701770	1150442	1433628	
125	11.6	Input power - HP	18.9	22.9	43	55.2	99.2	133	211	270	
		Output torque - lb-in	97345	122124	226549	302655	518584	701770	1150442	1433628	
140	10.4	Input power - HP	17.2	20.2	39	48.7	90.0	121	196	236	
		Output torque - lb-in	97345	123894	226549	302655	518584	701770	1150442	1433628	
160	9.06	Input power - HP	15.4	17.8	33	45.2	80.3	107	176	220	
		Output torque - lb-in	97345	123894	226549	302655	518584	701770	1150442	1433628	
180	8.06	Input power - HP	13.8	16.5	29	41.0	73.0	97.1	148	196	
		Output torque - lb-in	97345	123894	226549	302655	518584	701770	1150442	1433628	
200	7.25	Input power - HP	12.2	14.8	27	34.6	64.4	86.6	129	166	
		Output torque - lb-in	97345	123894	226549	302655	518584	701770	1150442	1433628	
225	6.44	Input power - HP	-	13.0	-	30.4	-	78.7	120	145	
		Output torque - lb-in	-	123894	-	302655	-	701770	1150442	1433628	
250	5.80	Input power - HP	-	11.4	-	28.3	-	69.5	-	135	
		Output torque - lb-in	-	123894	-	302655	-	701770	-	1433628	

SERIES G

PARALLEL SHAFT UNIT MECHANICAL RATINGS AT 1160 RPM INPUT

Nominal Ratio Column Entry	Nominal Output Speed RPM	Mechanical Capacity	PARALLEL SHAFT UNITS - SIZE								
			G14	G15	G16	G17	G18	G19	G21	G22	
6.3	184	Input power - HP	287	-	554	-	1257	-	-	-	DOUBLE REDUCTION
		Output torque - lb-in	92035	-	191150	-	422124	-	-	-	
7.1	163	Input power - HP	253	-	536	-	1181	-	1998	-	
		Output torque - lb-in	93805	-	200000	-	438053	-	787611	-	
8.0	145	Input power - HP	232	283	499	554	1067	1257	1998	1998	
		Output torque - lb-in	94690	115044	203540	246018	453097	529204	867257	877876	
9.0	129	Input power - HP	212	251	463	536	992	1181	1998	1998	
		Output torque - lb-in	96460	117699	215929	257522	469027	549558	973451	973451	
10	116	Input power - HP	193	229	426	499	956	1067	1998	1998	
		Output torque - lb-in	97345	118584	223009	261947	493805	569027	1079646	1097345	
11	105	Input power - HP	174	209	388	463	880	992	1891	1998	
		Output torque - lb-in	97345	119469	226549	276991	509735	588496	1141593	1203540	
12	96.7	Input power - HP	157	190	341	426	764	956	1690	1998	
		Output torque - lb-in	97345	121239	226549	286726	516814	619469	1150442	1345133	
14	82.9	Input power - HP	139	173	299	389	697	880	1489	1810	
		Output torque - lb-in	97345	122124	226549	292035	518584	639823	1150442	1371681	
16	72.5	Input power - HP	123	154	278	354	617	764	1301	1596	
		Output torque - lb-in	97345	123009	226549	303540	518584	647788	1150442	1371681	
18	64.4	Input power - HP	104	138	240	315	566	728	1207	1435	
		Output torque - lb-in	94690	123894	223894	306195	518584	678761	1150442	1407080	
20	58.0	Input power - HP	96.1	122	216	298	518	652	1057	1354	
		Output torque - lb-in	97345	123894	226549	311504	518584	686726	1150442	1424779	
22	52.7	Input power - HP	86.9	104	193	240	463	570	944	1161	
		Output torque - lb-in	97345	119469	226549	288496	518584	655752	1150442	1407080	
25	46.4	Input power - HP	78.0	94.9	169	227	396	558	838	1054	
		Output torque - lb-in	97345	121239	226549	307080	518584	700000	1150442	1424779	
28	41.4	Input power - HP	69.6	85.8	149	205	359	498	740	936	
		Output torque - lb-in	97345	122124	226549	308850	518584	700000	1150442	1424779	
32	36.3	Input power - HP	61.6	77.1	138	181	318	426	646	826	
		Output torque - lb-in	97345	123009	226549	311504	518584	700885	1150442	1424779	
36	32.2	Input power - HP	53.1	68.8	122	160	284	388	602	723	
		Output torque - lb-in	97345	123894	226549	312389	518584	700885	1150442	1424779	
40	29.0	Input power - HP	48.3	60.7	108	149	260	342	535	673	
		Output torque - lb-in	97345	123894	226549	313274	518584	700885	1150442	1424779	
45	25.8	Input power - HP	43.7	52.4	97.4	127	232	306	479	599	
		Output torque - lb-in	97345	119469	226549	304425	518584	700885	1150442	1424779	
50	23.2	Input power - HP	39.3	47.7	85.4	114	198	280	425	535	
		Output torque - lb-in	97345	121239	226549	307080	518584	700885	1150442	1424779	
56	20.7	Input power - HP	35.0	43.2	75.2	103	181	249	374	475	
		Output torque - lb-in	97345	122124	226549	308850	518584	700885	1150442	1433628	
63	18.4	Input power - HP	30.8	38.8	69.7	91.1	160	215	327	418	
		Output torque - lb-in	97345	123894	226549	311504	518584	701770	1150442	1433628	
71	16.3	Input power - HP	26.0	34.6	61.7	80.5	138	194	304	366	
		Output torque - lb-in	94690	123894	226549	312389	515929	701770	1150442	1433628	
80	14.5	Input power - HP	23.7	30.6	54.3	74.8	126	172	280	341	
		Output torque - lb-in	95575	123894	226549	313274	518584	701770	1150442	1433628	
90	12.9	Input power - HP	21.5	25.5	50.4	64.0	111	149	245	314	
		Output torque - lb-in	96460	117699	226549	302655	518584	701770	1150442	1433628	
100	11.6	Input power - HP	19.2	22.9	42.5	56.5	98.8	135	228	275	
		Output torque - lb-in	97345	118584	226549	303540	518584	701770	1150442	1433628	
112	10.4	Input power - HP	17.2	20.5	37.5	52.4	89.8	120	193	256	
		Output torque - lb-in	97345	120354	226549	303540	518584	701770	1150442	1433628	
125	9.28	Input power - HP	15.2	18.4	34.7	44.1	79.4	107	169	216	
		Output torque - lb-in	97345	122124	226549	302655	518584	701770	1150442	1433628	
140	8.29	Input power - HP	13.8	16.2	31.6	38.9	72.0	97.0	157	189	
		Output torque - lb-in	97345	123894	226549	302655	518584	701770	1150442	1433628	
160	7.25	Input power - HP	12.3	14.2	26.7	36.2	64.2	85.6	139	176	
		Output torque - lb-in	97345	123894	226549	303540	518584	701770	1150442	1433628	
180	6.44	Input power - HP	11.0	13.1	23.5	32.9	58.3	77.6	119	157	
		Output torque - lb-in	97345	123894	226549	303540	518584	701770	1150442	1433628	
200	5.80	Input power - HP	9.79	11.8	21.9	27.6	51.5	69.3	104	133	
		Output torque - lb-in	97345	123894	226549	302655	518584	701770	1150442	1433628	
225	5.16	Input power - HP	-	10.5	-	24.4	-	62.9	96.4	116	
		Output torque - lb-in	-	123894	-	302655	-	701770	1150442	1433628	
250	4.64	Input power - HP	-	9.12	-	22.7	-	55.5	-	108	
		Output torque - lb-in	-	123894	-	302655	-	701770	-	1433628	

SERIES G

PARALLEL SHAFT UNIT MECHANICAL RATINGS AT 875 RPM INPUT

Nominal Ratio Column Entry	Nominal Output Speed RPM	Mechanical Capacity	PARALLEL SHAFT UNITS - SIZE								
			G14	G15	G16	G17	G18	G19	G21	G22	
6.3	139	Input power - HP	216	-	430	-	1002	-	-	-	DOUBLE REDUCTION
		Output torque - lb-in	92035	-	197345	-	446018	-	-	-	
7.1	123	Input power - HP	191	-	428	-	942	-	1509	-	
		Output torque - lb-in	93805	-	211504	-	462832	-	787611	-	
8.0	109	Input power - HP	175	214	398	430	852	1002	1509	1515	
		Output torque - lb-in	95575	115044	215929	253097	479646	559292	867257	876991	
9.0	97.2	Input power - HP	160	189	367	428	792	942	1509	1515	
		Output torque - lb-in	96460	117699	225664	272566	496460	580531	973451	973451	
10	87.5	Input power - HP	145	174	326	398	757	852	1509	1515	
		Output torque - lb-in	97345	118584	226549	276991	518584	601770	1079646	1097345	
11	79.5	Input power - HP	132	158	293	370	676	792	1435	1515	
		Output torque - lb-in	97345	119469	226549	293805	518584	623009	114159	1203540	
12	72.9	Input power - HP	118	144	257	341	579	763	1274	1515	
		Output torque - lb-in	97345	121239	226549	303540	518584	655752	1150442	1345133	
14	62.5	Input power - HP	105	130	226	310	527	703	1126	1421	
		Output torque - lb-in	97345	122124	226549	308850	518584	676106	1150442	1424779	
16	54.7	Input power - HP	93.0	117	210	275	466	611	979	1250	
		Output torque - lb-in	97345	123009	226549	311504	518584	685841	1150442	1424779	
18	48.6	Input power - HP	79.1	104	182	242	428	567	912	1097	
		Output torque - lb-in	95575	123894	226549	312389	518584	700000	1150442	1424779	
20	43.8	Input power - HP	72.5	91.9	163	226	391	501	798	1022	
		Output torque - lb-in	97345	123894	226549	313274	518584	700000	1150442	1424779	
22	39.8	Input power - HP	65.5	78.7	145	191	348	430	713	892	
		Output torque - lb-in	97345	119469	226549	304425	518584	654867	1150442	1424779	
25	35.0	Input power - HP	58.9	71.6	128	171	299	422	634	797	
		Output torque - lb-in	97345	121239	226549	307080	1965	700885	1150442	1424779	
28	31.3	Input power - HP	52.6	64.8	113	154	271	375	559	708	
		Output torque - lb-in	97345	122124	226549	308850	518584	700885	1150442	1424779	
32	27.3	Input power - HP	46.3	58.2	105	137	240	323	488	625	
		Output torque - lb-in	97345	123009	226549	311504	518584	700000	1150442	1424779	
36	24.3	Input power - HP	40.1	51.8	92.0	121	214	293	455	547	
		Output torque - lb-in	96460	123894	226549	312389	518584	700000	1150442	1424779	
40	21.9	Input power - HP	36.4	45.8	81.8	112	196	259	404	508	
		Output torque - lb-in	97345	123894	226549	313274	518584	700885	1150442	1424779	
45	19.4	Input power - HP	33.0	39.6	73.5	95.9	175	231	361	452	
		Output torque - lb-in	97345	119469	226549	304425	518584	656637	1150442	1433628	
50	17.5	Input power - HP	29.6	35.9	64.4	86.2	150	211	320	404	
		Output torque - lb-in	97345	121239	226549	307080	518584	700885	1150442	1433628	
56	15.6	Input power - HP	26.4	32.5	56.7	77.7	136	188	283	358	
		Output torque - lb-in	97345	122124	226549	308850	518584	700885	1150442	1433628	
63	13.9	Input power - HP	23.3	29.2	52.6	68.7	120	161	247	316	
		Output torque - lb-in	97345	123894	226549	311504	518584	700885	1150442	1433628	
71	12.3	Input power - HP	19.7	26.0	46.4	60.6	104	147	229	276	
		Output torque - lb-in	94690	123894	226549	312389	518584	700885	1150442	1433628	
80	10.9	Input power - HP	17.8	23.0	40.9	56.5	94.7	130	212	257	
		Output torque - lb-in	95575	123894	226549	313274	518584	700885	1150442	1433628	
90	9.72	Input power - HP	16.1	19.2	38.0	48.3	83.6	112	185	237	
		Output torque - lb-in	96460	117699	226549	302655	518584	701770	1150442	1433628	
100	8.75	Input power - HP	14.5	17.4	32.1	42.4	74.6	102	173	208	
		Output torque - lb-in	97345	118584	226549	302655	518584	701770	1150442	1433628	
112	7.81	Input power - HP	13.0	15.5	28.2	39.5	67.7	90.2	146	193	
		Output torque - lb-in	97345	120354	226549	303540	518584	701770	1150442	1433628	
125	7.00	Input power - HP	11.4	13.8	26.3	33.2	59.8	80.4	127	164	
		Output torque - lb-in	97345	122124	226549	302655	518584	701770	1150442	1433628	
140	6.25	Input power - HP	10.4	12.2	23.8	29.3	54.3	73.1	119	142	
		Output torque - lb-in	97345	123894	226549	302655	518584	701770	1150442	1433628	
160	5.47	Input power - HP	9.29	10.8	20.2	27.3	48.4	64.5	106	133	
		Output torque - lb-in	97345	123894	226549	303540	518584	701770	1150442	1433628	
180	4.86	Input power - HP	8.31	9.90	17.7	24.8	44.0	58.5	89.3	118	
		Output torque - lb-in	97345	123894	226549	303540	518584	701770	1150442	1433628	
200	4.38	Input power - HP	7.33	8.92	16.5	20.9	38.9	52.2	78.0	100	
		Output torque - lb-in	94690	123894	226549	302655	518584	701770	1150442	1433628	
225	3.89	Input power - HP	-	7.82	-	18.3	-	47.4	72.7	87.4	
		Output torque - lb-in	-	123894	-	302655	-	701770	1150442	1433628	
250	3.50	Input power - HP	-	6.84	-	17.1	-	41.9	-	81.4	
		Output torque - lb-in	-	123894	-	303540	-	701770	-	1433628	

SERIES G

PARALLEL SHAFT UNIT

THERMAL RATINGS

Thermal Ratings HP

These thermal ratings assume the gear unit is in constant use working in an ambient temperature of 77°F (25°C)* installed in a large indoor space at sea level.

These ratings must be adjusted for alternative operating and environment conditions refer to Thermal ratings and service factors on page 6. Ratings are for reference purposes. Contact Application Engineering to confirm suitability for your application.

*maximum bulk oil temperature 203°F (95°C)

Parallel Shaft Units - Double Reduction

Type of Cooling	Input Speed (rev/min)	Ratio	G1420	G1520	G1620	G1720	G1820	G1920	G2120	G2220
No Additional Cooling	1750	8:1	110	123	185	176	291	221	263	278
		16:1	84	98	153	149	241	218	236	252
	1450	8:1	109	121	191	182	306	246	314	332
		16:1	84	98	159	156	256	244	285	304
	1160	8:1	109	120	195	188	320	269	357	377
		16:1	85	97	164	162	270	266	327	348
960	8:1	108	119	199	192	328	283	385	406	
	16:1	85	97	168	166	278	280	353	376	
Fan Cooling	1750	8:1	198	202	320	309	501	467	556	588
		16:1	162	170	280	274	432	463	518	552
	1450	8:1	175	179	292	280	453	424	520	550
		16:1	142	150	253	247	390	421	484	516
	1160	8:1	153	157	264	251	406	383	486	514
		16:1	123	131	227	221	348	380	451	481
960	8:1	137	142	244	231	374	354	462	488	
	16:1	110	118	209	202	320	352	427	456	
Cooling Coil	1750	8:1	300	319	498	507	876	748	783	821
		16:1	256	281	451	466	789	744	741	782
	1450	8:1	294	312	498	505	873	750	804	842
		16:1	252	276	451	464	788	746	762	804
	1160	8:1	289	307	498	502	871	752	823	863
		16:1	248	271	451	463	786	748	781	824
960	8:1	285	303	497	501	869	754	835	877	
	16:1	245	268	451	462	786	750	794	838	
Fan and Cooling Coil	1750	8:1	355	366	578	582	1000	889	956	1002
		16:1	309	326	528	539	908	885	911	961
	1450	8:1	335	347	557	559	960	854	928	974
		16:1	291	309	508	518	872	849	884	934
	1160	8:1	315	329	537	537	923	819	901	946
		16:1	273	293	489	498	837	815	858	907
960	8:1	302	317	523	523	897	796	883	927	
	16:1	261	281	476	483	813	792	840	888	

Parallel Shaft Units - Triple Reduction

Type of Cooling	Input Speed (rev/min)	Ratio	G1430	G1530	G1630	G1730	G1830	G1930	G2130	G2230
No Additional Cooling	1750	22:1	78	83	123	119	197	169	183	194
		56:1	52	60	91	93	146	130	155	167
	1450	22:1	75	81	124	122	202	186	215	228
		56:1	52	59	92	96	153	147	185	199
	1160	22:1	73	78	124	124	208	200	242	256
		56:1	52	58	94	99	160	161	211	226
960	22:1	72	77	124	126	211	209	259	274	
	56:1	51	58	95	101	164	170	228	244	
Fan Cooling	1750	22:1	-	-	238	242	411	444	514	537
		56:1	-	-	191	204	334	378	471	497
	1450	22:1	-	-	211	216	365	397	471	493
		56:1	-	-	169	181	295	336	430	454
	1160	22:1	-	-	186	190	320	351	428	448
		56:1	-	-	147	159	257	296	389	411
960	22:1	-	-	168	173	289	319	397	417	
	56:1	-	-	132	143	231	268	360	381	
Cooling Coil	1750	22:1	210	219	336	344	578	574	534	562
		56:1	166	182	283	301	489	502	491	521
	1450	22:1	203	212	331	340	570	571	545	573
		56:1	161	177	280	298	484	501	502	532
	1160	22:1	197	206	326	336	563	569	555	584
		56:1	157	172	276	295	479	501	512	543
960	22:1	193	202	323	333	558	568	561	591	
	56:1	155	169	274	293	476	500	519	551	

Parallel Shafts - Quadruple Reduction

Type of Cooling	Input Speed (rev/min)	Ratio	G1440	G1540	G1640	G1740	G1840	G1940	G2140	G2240
No Additional Cooling	1750	100:1	48	56	84	87	138	137	156	173
		200:1	35	40	61	68	108	109	123	139
	1450	100:1	47	54	84	88	142	146	180	198
		200:1	35	40	62	70	113	119	147	163
	1160	100:1	46	52	84	88	146	154	200	218
		200:1	35	39	63	71	117	127	166	183
960	100:1	46	52	84	89	148	158	213	231	
	200:1	34	39	63	72	120	132	178	196	

SERIES G DIMENSIONS HORIZONTAL PARALLEL SHAFTS DOUBLE REDUCTION

G

		2	0			H
--	--	---	---	--	--	---

Double Reduction Parallel Shaft Units Horizontal

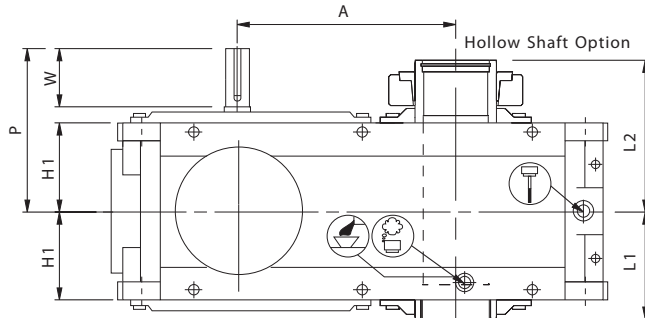
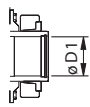
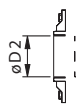
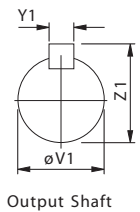
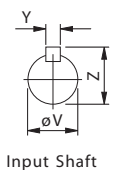
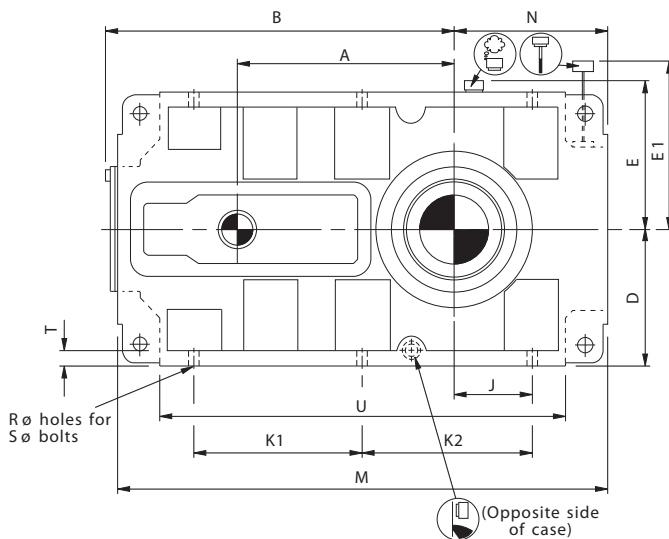
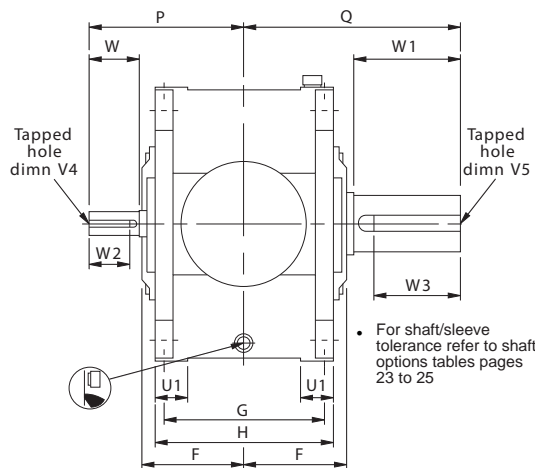

* Maximum bolt length

Unit Size	A	B	D	E	E1	F	G	H	H1	J	K1	K2	M	N	P	Q	R	S	T	U	U1
G14	12.80	21.81	9.06	9.84	14.57	6.97	10.43	11.81	5.91	6.69	11.22	32.28	11.61	12.40	14.17	0.73	6 x M16 x 60*	0.98	26.93	2.17	
G15	14.37	23.39	9.06	9.84	14.57	6.97	10.43	11.81	5.91	5.12	11.22	32.28	10.04	12.40	14.57	0.73	6 x M16 x 60*	0.98	26.93	2.17	
G16	16.93	28.66	11.81	13.19	20.28	8.86	12.99	14.96	7.48	8.86	15.16	41.73	14.57	14.57	18.11	1.10	6 x M24 x 80*	1.18	35.35	2.76	
G17	19.09	30.83	11.81	13.19	20.28	8.86	12.99	14.96	7.48	6.69	15.16	41.73	12.40	14.57	18.90	1.10	6 x M24 x 80*	1.18	35.35	2.76	
G18	22.44	37.52	15.16	16.54	27.95	11.42	17.32	19.69	9.84	6.02	20.47	13.78	48.82	13.31	18.90	23.62	1.30	6 x M30 x 100*	1.46	40.79	3.54
G19	25.00	40.08	15.16	16.54	27.95	11.42	17.32	19.69	9.84	8.66	19.69	54.09	16.02	18.90	25.59	1.30	6 x M30 x 100*	1.57	46.06	3.54	
G21	30.12	48.82	18.31	19.96	29.53	13.39	20.87	23.62	11.81	8.86	27.36	18.90	65.16	18.31	22.05	27.56	1.54	6 x M36 x 100*	1.97	54.33	4.72
G22	31.69	50.39	18.31	19.96	29.53	13.39	20.87	23.62	11.81	9.65	29.33	19.29	67.52	19.09	22.05	28.74	1.54	6 x M36 x 100*	1.97	56.69	4.72

Unit Size	Input Shaft						Output Shaft						Output Bore			
	V	V4	W	W2	Y	Z	V1	V5	W1	W3	Y1	Z1	D1	D2	L1	L2
G14	1.875	5/8 UNF x 1.25	5.31	4.13	0.500	2.10	4.500	1 UNF x 2	7.09	6.50	1.00	4.94	3.74	3.94	7.09	10.04
G15	1.875	5/8 UNF x 1.25	5.31	4.13	0.500	2.10	5.000	1 UNF x 2	7.48	7.13	1.25	5.55	4.33	4.53	7.09	10.24
G16	2.250	3/4 UNF x 1.62	5.71	4.13	0.500	2.47	6.000	1.25 UNF x 2.5	9.06	8.75	1.50	6.66	4.92	5.12	9.06	12.80
G17	2.250	3/4 UNF x 1.62	5.71	4.13	0.500	2.47	6.750	1.25 UNF x 2.5	9.84	9.38	1.75	7.39	5.71	5.91	9.06	13.39
G18	3.250	1 UNF x 2	7.48	5.88	0.750	3.58	7.500	1.5 UNF x 3	11.81	11.38	1.75	8.15	6.30	6.69	11.81	16.14
G19	3.250	1 UNF x 2	7.48	5.88	0.750	3.58	8.250	1.5 UNF x 3	13.78	13.00	2.00	8.88	6.69	7.09	11.81	16.93
G21	4.250	1 UNF x 2	8.27	7.50	1.000	4.69	8.500	1.5 UNF x 3	13.78	13.00	2.00	9.13	8.27	8.66	13.78	19.69
G22	4.250	1 UNF x 2	8.27	7.5	1.000	4.69	9.250	1.5 UNF x 3	14.96	14.25	2.50	9.95	9.06	9.45	13.78	20.28

SERIES G

DIMENSIONS VERTICAL PARALLEL

SHAFTS DOUBLE REDUCTION

G 2 0 V

Double Reduction Parallel Shaft Units Vertical

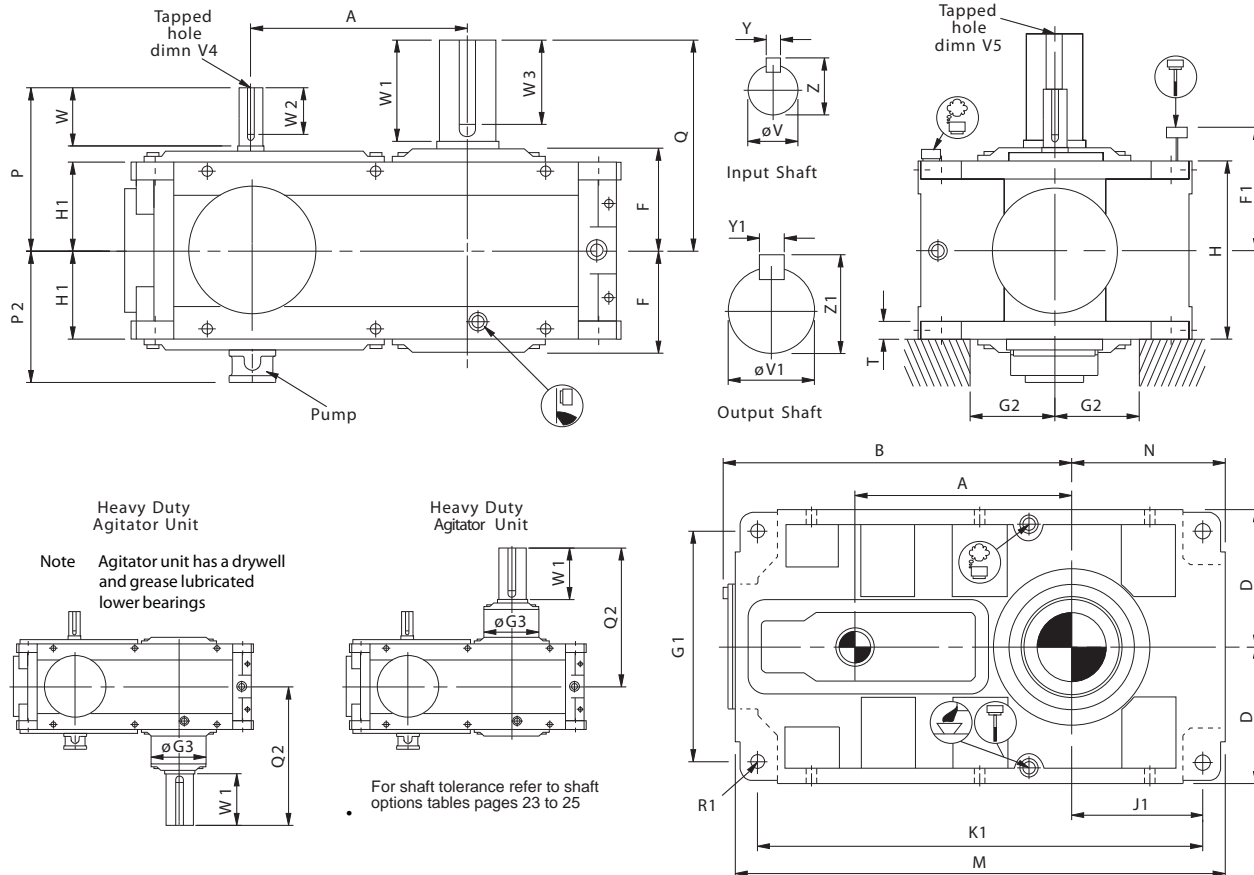

Unit Size	A	B	D	F	F1	G1	G2	G3	H	H1	J1	K1	M	N	P	P2	Q	Q2	R1	T
G14	12.80	21.81	9.06	6.97	15.35	15.35	5.31	9.06	11.81	5.91	10.24	29.53	32.28	11.61	12.40	9.29	14.17	18.70	4 X Ø 24	1.18
G15	14.37	23.39	9.06	6.97	15.35	15.35	5.31	10.24	11.81	5.91	8.66	29.53	32.28	10.04	12.40	9.29	14.57	19.49	4 X Ø 24	1.18
G16	16.93	28.66	11.81	8.86	20.28	19.92	6.89	11.81	14.96	7.48	12.80	38.19	41.73	14.57	14.57	11.22	18.11	23.43	4 X Ø 33	1.77
G17	19.09	30.83	11.81	8.86	20.28	19.92	6.89	13.39	14.96	7.48	10.63	38.19	41.73	12.40	14.57	11.22	18.90	24.21	4 X Ø 33	1.77
G18	22.44	37.52	15.16	11.42	27.56	25.83	8.07	14.57	19.69	9.84	11.06	44.33	48.82	13.31	18.90	13.58	23.62	29.92	4 X Ø 40	2.17
G19	25.00	40.08	15.16	11.42	27.56	25.83	8.07	15.75	19.69	9.84	13.78	49.61	54.09	16.02	18.90	13.58	25.59	32.09	4 X Ø 40	2.17
G21	30.12	48.82	18.31	13.39	29.53	31.10	10.04	19.69	23.62	11.81	15.55	59.65	65.16	18.31	22.05	15.75	27.56	36.42	4 X Ø 48	2.76
G22	31.69	50.39	18.31	13.39	29.53	31.10	10.43	*	23.62	11.81	16.34	62.01	67.52	19.09	22.05	15.75	28.74	*	4 X Ø 48	2.76

Unit Size	Input Shaft						Output Shaft					
	V	V4	W	W2	Y	Z	V1	V5	W1	W3	Y1	Z1
G14	1.875	5/8 UNF x 1.25	5.31	4.13	0.500	2.10	4.500	1 UNF x 2	7.09	6.50	1.00	4.94
G15	1.875	5/8 UNF x 1.25	5.31	4.13	0.500	2.10	5.000	1 UNF x 2	7.48	7.13	1.25	5.55
G16	2.250	3/4 UNF x 1.62	5.71	4.13	0.500	2.47	6.000	1.25 UNF x 2.5	9.06	8.75	1.50	6.66
G17	2.250	3/4 UNF x 1.62	5.71	4.13	0.500	2.47	6.750	1.25 UNF x 2.5	9.84	9.38	1.75	7.39
G18	3.250	1 UNF x 2	7.48	5.88	0.750	3.58	7.500	1.5 UNF x 3	11.81	11.38	1.75	8.15
G19	3.250	1 UNF x 2	7.48	5.88	0.750	3.58	8.250	1.5 UNF x 3	13.78	13.00	2.00	8.88
G21	4.250	1 UNF x 2	8.27	7.50	1.000	4.69	8.500	1.5 UNF x 3	13.78	13.00	2.00	9.13
G22	4.250	1 UNF x 2	8.27	7.50	1.000	4.69	9.250	1.5 UNF x 3	14.96	14.25	2.50	9.95

SERIES G

DIMENSIONS HORIZONTAL PARALLEL SHAFTS TRIPLE & QUADRUPLE REDUCTION

G		3	0		H
		4			

Triple and Quadruple Reduction Parallel Shaft Units Horizontal

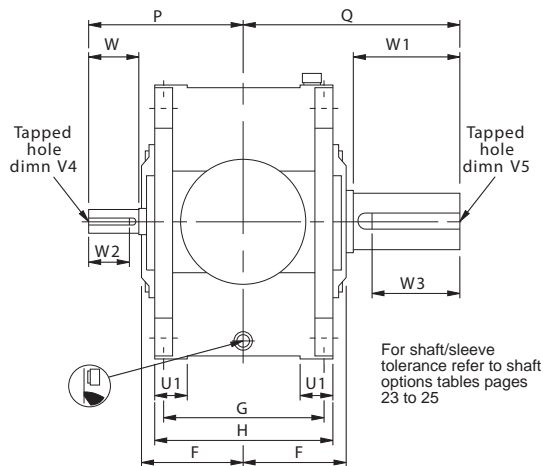

For shaft/sleeve tolerance refer to shaft options tables pages 23 to 25

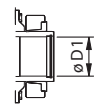
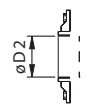
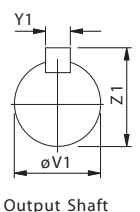
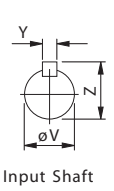

Output Bore

* Maximum bolt length

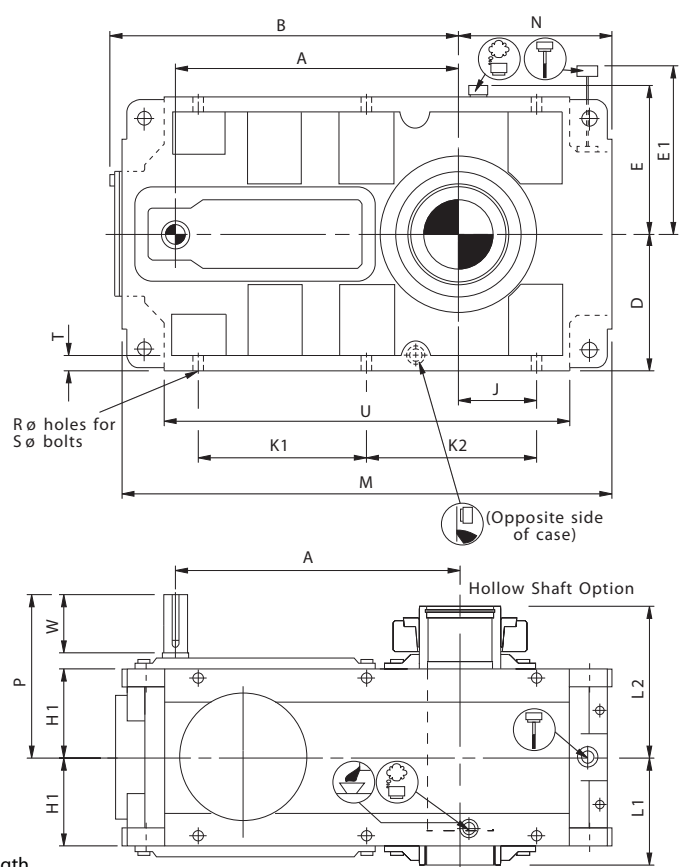

Unit Size	A	B	D	E	E1	F	G	H	H1	J	K1	K2	M	N	P	Q	R	S	T	U	U1
G14	17.13	21.81	9.06	9.84	14.57	6.97	10.43	11.81	5.91	6.69	11.22		32.28	11.61	10.83	14.17	0.73	6 X m16 X 60*	0.98	26.93	2.17
G15	18.70	23.39	9.06	9.84	14.57	6.97	10.43	11.81	5.91	5.12	11.22		32.28	10.04	10.83	14.57	0.73	6 X m16 X 60*	0.98	26.93	2.17
G16	22.44	28.66	11.81	13.19	20.28	8.86	12.99	14.96	7.48	8.86	15.16		41.73	14.57	13.39	18.11	1.10	6 X m24 X 80*	1.18	35.35	2.76
G17	24.61	30.83	11.81	13.19	20.28	8.86	12.99	14.96	7.48	6.69	15.16		41.73	12.40	13.39	18.90	1.10	6 X m24 X 80*	1.18	35.35	2.76
G18	29.72	37.52	15.16	16.54	27.95	11.42	17.32	19.69	9.84	6.02	20.47	13.78	48.82	13.31	17.32	23.62	1.30	6 X m30 X 100*	1.46	40.79	3.54
G19	32.28	40.08	15.16	16.54	27.95	11.42	17.32	19.69	9.84	8.66	19.69		54.09	16.02	17.32	25.59	1.30	6 X m30 X 100*	1.57	46.06	3.54
G21	39.76	48.82	18.31	19.96	29.53	13.39	20.87	23.62	11.81	8.86	27.36	18.90	65.16	18.31	21.26	27.56	1.54	6 X m36 X 100*	1.97	54.33	4.72
G22	41.34	50.39	18.31	19.96	29.53	13.39	20.87	23.62	11.81	9.65	29.33	19.29	67.52	19.09	21.26	28.74	1.54	6 X m36 X 100*	1.97	56.69	4.72

Unit Size	Input Shaft						Output Shaft						Output Bore			
	V	V4	W	W2	Y	Z	V1	V5	W1	W3	Y1	Z1	D1	D2	L1	L2
G14	1.375	1/2 UNF x 1	3.74	3.00	0.313	1.51	4.500	1 UNF x 2	7.09	6.50	1.00	4.94	3.74	3.94	7.09	10.04
G15	1.375	1/2 UNF x 1	3.74	3.00	0.313	1.51	5.000	1 UNF x 2	7.48	7.13	1.25	5.55	4.33	4.53	7.09	10.24
G16	1.750	5/8 UNF x 1.25	4.53	4.13	0.375	1.92	6.000	1.25 UNF x 2.5	9.06	8.75	1.50	6.66	4.92	5.12	9.06	12.80
G17	1.750	5/8 UNF x 1.25	4.53	4.13	0.375	1.92	6.750	1.25 UNF x 2.5	9.84	9.38	1.75	7.39	5.71	5.91	9.06	13.39
G18	2.250	3/4 UNF x 1.62	5.71	4.13	0.500	2.47	7.500	1.5 UNF x 3	11.81	11.38	1.75	8.15	6.30	6.69	11.81	16.14
G19	2.250	3/4 UNF x 1.62	5.71	4.13	0.500	2.47	8.250	1.5 UNF x 3	13.78	13.00	2.00	8.88	6.69	7.09	11.81	16.93
G21	3.000	3/4 UNF x 1.62	7.48	6.50	0.750	3.33	8.500	1.5 UNF x 3	13.78	13.00	2.00	9.13	8.27	8.66	13.78	19.69
G22	3.000	3/4 UNF x 1.62	7.48	6.50	0.750	3.33	9.250	1.5 UNF x 3	14.26	14.25	2.50	9.95	9.06	9.45	13.78	20.28

SERIES G

DIMENSIONS VERTICAL PARALLEL

SHAFTS TRIPLE & QUADRUPLE REDUCTION

Triple and Quadruple Reduction Parallel Shaft Units Horizontal

G		3	0			V
		4				

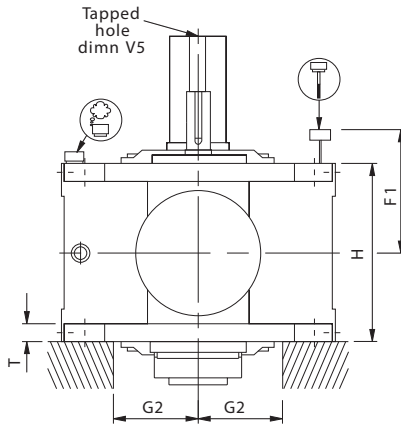
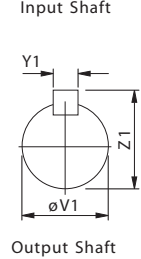
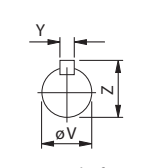
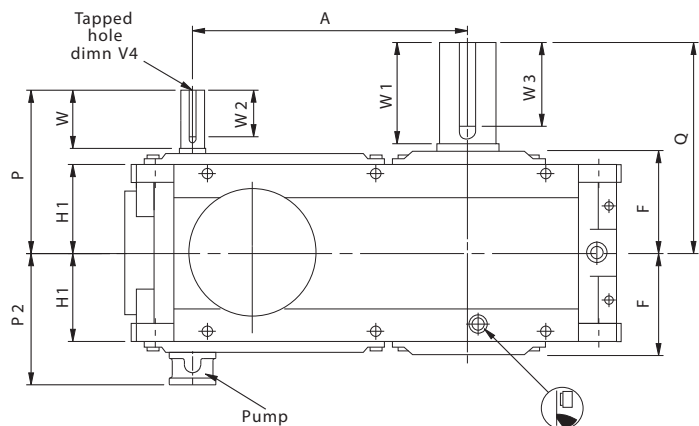

Heavy Duty Agitator Unit
 Note Agitator unit has a drywell and grease lubricated lower bearings

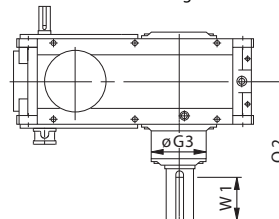

Heavy Duty Agitator Unit

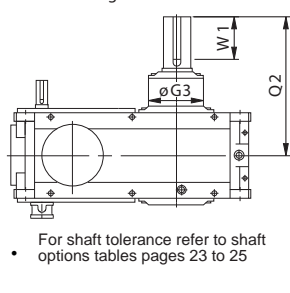

• For shaft tolerance refer to shaft options tables pages 23 to 25

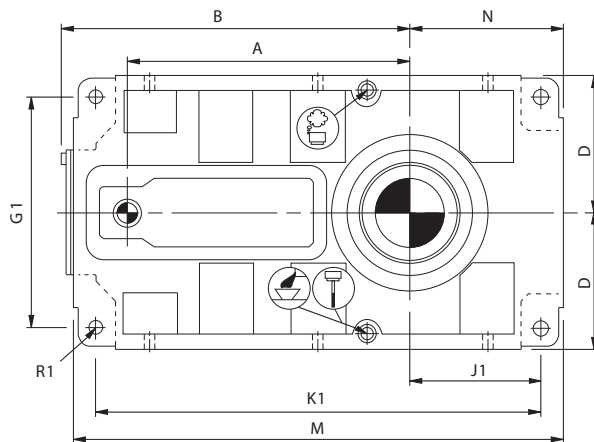

Unit Size	A	B	D	F	F1	G1	G2 min	G3	H	H1	J1	K1	M	N	P	P2	Q	Q2	R1	T
G14	17.13	21.81	9.06	6.97	15.35	15.35	5.31	9.06	11.81	5.91	10.24	29.53	32.28	11.61	10.83	9.29	14.17	18.70	4 X ϕ 24	1.18
G15	18.70	23.39	9.06	6.97	15.35	15.35	5.31	10.24	11.81	5.91	8.66	29.53	32.28	10.04	10.83	9.29	14.57	19.49	4 X ϕ 24	1.18
G16	22.44	28.66	11.81	8.86	20.28	19.92	6.89	11.81	14.96	7.48	12.80	38.19	41.73	14.57	13.39	11.22	18.11	23.43	4 X ϕ 33	1.77
G17	24.61	30.83	11.81	8.86	20.28	19.92	6.89	13.39	14.96	7.48	10.63	38.19	41.73	12.40	13.39	11.22	18.90	24.21	4 X ϕ 33	1.77
G18	29.72	37.52	15.16	11.42	27.56	25.83	8.07	14.57	19.69	9.84	11.06	44.33	48.82	13.31	17.32	13.58	23.62	29.92	4 X ϕ 40	2.17
G19	32.28	40.08	15.16	11.42	27.56	25.83	8.07	15.75	19.69	9.84	13.78	49.61	54.09	16.02	17.32	13.58	25.59	32.09	4 X ϕ 40	2.17
G21	39.76	48.82	18.31	13.39	29.53	31.10	10.04	19.69	23.62	11.81	15.55	59.65	65.16	18.31	21.26	15.75	27.56	36.42	4 X ϕ 48	2.76
G22	41.34	50.39	18.31	13.39	29.53	31.10	10.43	*	23.62	11.81	16.34	62.01	67.52	19.09	21.26	15.75	28.74	*	4 X ϕ 48	2.76

Unit Size	Input Shaft						Output Shaft					
	V	V4	W	W2	Y	Z	V1	V5	W1	W3	Y1	Z1
G14	1.375	5/8 UNF x 1.25	5.31	4.13	0.500	2.10	4.500	1 UNF x 2	7.09	6.50	1.00	4.94
G15	1.375	5/8 UNF x 1.25	5.31	4.13	0.500	2.10	5.000	1 UNF x 2	7.48	7.13	1.25	5.55
G16	1.750	3/4 UNF x 1.62	5.71	4.13	0.500	2.47	6.000	1.25 UNF x 2.5	9.06	8.75	1.50	6.66
G17	1.750	3/4 UNF x 1.62	5.71	4.13	0.500	2.47	6.750	1.25 UNF x 2.5	9.84	9.38	1.75	7.39
G18	2.250	1 UNF x 2	7.48	5.88	0.750	3.58	7.500	1.5 UNF x 3	11.81	11.38	1.75	8.15
G19	2.250	1 UNF x 2	7.48	5.88	0.750	3.58	8.250	1.5 UNF x 3	13.78	13.00	2.00	8.88
G21	3.000	1 UNF x 2	8.27	7.50	1.000	4.69	8.500	1.5 UNF x 3	13.78	13.00	2.00	9.13
G22	3.000	1 UNF x 2	8.27	7.50	1.000	4.69	9.250	1.5 UNF x 3	14.96	14.25	2.50	9.95

SERIES G

FAN COOLING DIMENSIONS

PARALLEL SHAFTS

Parallel Shaft Units with Mechanical Fans

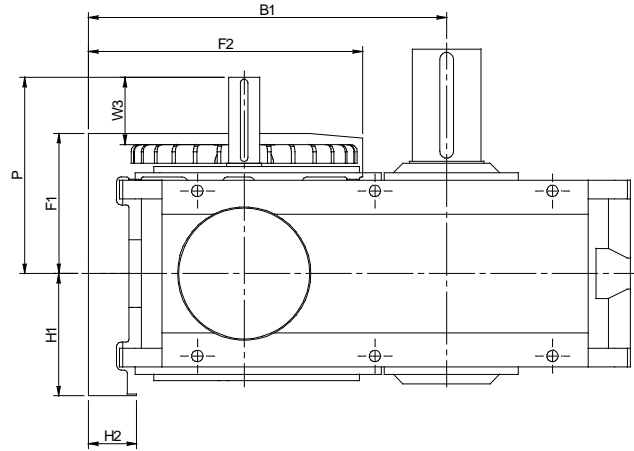
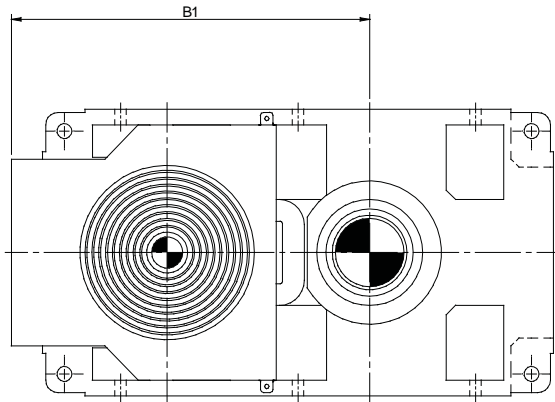

Double Reduction

Unit Size	B1	F1	F2	H1	H2	P	W3 (Useable shaft extension)
G14	23.03	8.86	17.80	7.87	2.48	12.40	4.25
G15	24.61	8.86	17.80	7.87	2.48	12.40	4.25
G16	30.16	11.06	22.87	9.65	3.35	14.57	4.25
G17	32.32	11.06	22.87	9.65	3.35	14.57	4.25
G18	39.57	14.21	29.84	11.97	4.33	18.90	5.31
G19	42.13	14.21	29.84	11.97	4.33	18.90	5.31
G21	52.48	16.85	37.83	14.09	6.10	22.05	6.10
G22	54.06	16.85	37.83	14.09	6.10	22.05	6.10

Triple and Quadruple Reduction

Unit Size	B1	F1	F2	H1	H2	P	W3 (Useable shaft extension)
G14	Not Available						
G15	Not Available						
G16	30.16	10.55	18.54	9.65	3.35	13.39	3.07
G17	32.32	10.55	18.54	9.65	3.35	13.39	3.07
G18	39.57	13.78	24.53	11.97	4.33	17.32	4.33
G19	42.13	13.78	24.53	11.97	4.33	17.32	4.33
G21	52.48	16.85	31.61	14.09	6.10	21.26	5.31
G22	54.06	16.85	31.61	14.09	6.10	21.26	5.31

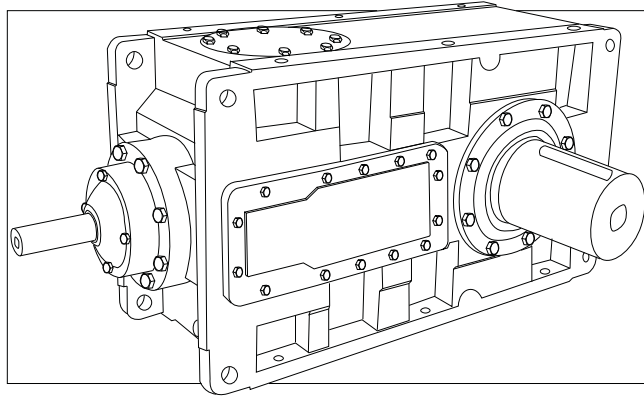

RIGHT ANGLE UNITS

<u>Contents</u>	<u>Page No</u>
Moments of Inertia _____	48
Exact Ratios _____	49
Mechanical Ratings - Input Power / Output Torque _____	50 - 53
Thermal Ratings _____	54
Dimension Sheets - Speed Reducers _____	55 - 61

SERIES G

MOMENTS OF INERTIA

RIGHT ANGLE SHAFTS

MOMENTS OF INERTIA (lb - in²) Referred to Input Shaft

RIGHT ANGLE UNITS - without fans

NOMINAL RATIO COLUMN ENTRY	RIGHT ANGLE SHAFT UNITS - SIZE											
	6	7	8	G14	G15	G16	G17	G18		G19	G21	G22
8.0				209	-	718	-	-	-	-	-	
9.0				193	-	705	-	-	10671	-	-	
10.				185	-	664	-	-	9918	10808	10808	
11.				176	-	626	-	-	9234	10055	10055	
12.				169	193	595	722	3482	8687	9371	9371	
14.				162	185	568	670	3300	8174	8824	8824	
16.				157	176	540	329	3218	7730	8311	8311	
18.				152	168	518	595	3078	7319	7832	7832	
20.				149	161	515	561	2893	6977	7422	7422	
22.				39	156	294	534	2846	6498	7080	7080	
25.				38	150	286	528	2740	2702	6909	6909	
28.				36	41	279	304	677	2589	2760	2760	
32.				34	39	272	294	657	2483	2638	2638	
36.				33	38	267	286	624	2398	2521	2521	
40.				32	36	265	277	580	2326	2428	2428	
45.				17	34	214	270	568	2288	2346	2346	
50.				15	32	210	268	544	1040	2305	2305	
56.				15	17	209	215	284	1006	1053	1053	
63.				14	15	207	212	265	978	1019	1019	
71.				-	15	149	210	260	964	988	988	
80.				-	14	149	209	250	2565	971	971	
90.				-	-	38	150	523	2538	2712	2712	
100				-	-	36	149	516	551	2702	2702	
112				-	-	36	38	287	540	612	612	
125				-	-	32	37	286	537	602	602	
140				-	-	32	36	282	499	599	599	
160				-	-	32	33	268	496	537	537	
180				-	-	16	32	267	493	530	530	
200				-	-	14	32	265	248	528	528	
225				-	-	14	16	215	233	274	274	
250				-	-	14	14	209	229	246	246	
280				-	-	-	14	209	229	245	245	
315				-	-	-	14	209	-	243	243	

TRIPLE REDUCTION

QUADRUPLE REDUCTION

RIGHT ANGLE UNITS - with fans

If fan cooling is required the inertia of the fan must be added to the table above.

MOMENTS OF INERTIA of fans (lb - in²)

	G14/G15	G16/G17	G18/G19	G21
TRIPLE REDUCTION	33	86	276	573

GD^2 (lb in²) = 4 x Moment of Inertia (lb - in²)

SERIES G EXACT RATIOS RIGHT ANGLE SHAFTS

EXACT RATIOS - RIGHT ANGLE UNITS

Triple Reduction

Nominal Ratio Column Entry 6 7 8	RIGHT ANGLE SHAFT UNITS - SIZE							
	G14	G15	G16	G17	G18	G19	G21	G22
8.0	7.691	-	8.095	-	7.842	-	-	-
9.0	8.863	-	8.755	-	8.663	-	9.127	-
10.	9.774	-	9.584	-	9.939	-	10.11	10.194
11.	10.816	-	10.937	-	11.08	-	11.434	11.291
12.	12.018	12.338	12.312	12.323	12.109	12.464	12.529	12.77
14.	13.42	13.653	13.718	14.062	13.586	13.893	14.041	13.993
16.	15.077	15.17	15.675	15.83	15.868	15.184	15.828	15.682
18.	17.065	16.94	17.807	17.637	17.474	17.037	17.973	17.678
20.	19.495	19.031	19.225	20.154	19.817	19.898	20.594	20.073
22.	21.775	21.541	21.756	22.894	22.636	21.912	22.136	23.001
25.	24.195	24.609	24.492	24.718	24.738	24.85	25.597	24.723
28.	27.017	27.487	27.288	27.972	27.757	28.384	28.686	28.589
32.	30.353	30.541	31.182	31.49	32.419	31.021	32.337	32.039
36.	34.356	34.104	35.422	35.084	35.7	34.806	36.718	36.117
40.	39.249	38.315	38.243	40.091	40.487	40.652	42.073	41.01
45.	41.605	43.368	43.244	45.543	42.83	44.767	45.223	46.991
50.	46.743	49.544	49.417	49.17	50.024	50.769	52.335	50.509
56.	52.907	52.518	56.136	55.6	55.087	53.708	59.426	58.452
63.	60.442	59.003	60.606	63.536	62.474	62.729	68.092	66.372
71.	-	66.784	-	72.174	-	69.078	73.19	76.051
80.	-	76.295	-	77.922	-	78.34	-	81.745

Quadruple Reduction

Nominal Ratio Column Entry 6 7 8	RIGHT ANGLE SHAFT UNITS - SIZE							
	G14	G15	G16	G17	G18	G19	G21	G22
71.	-	-	73.432	-	68.805	-	-	-
80.	-	-	79.28	-	78.03	-	83.586	-
90.	-	-	89.584	94.412	88.634	86.279	89.844	93.356
100	-	-	101.765	101.931	97.661	97.847	102.173	100.345
112	-	-	109.869	115.18	110.755	111.207	117.073	114.115
125	-	-	130.142	130.84	124.29	122.463	125.838	130.757
140	-	-	147.837	141.26	136.87	138.883	149.034	140.546
160	-	-	159.611	167.326	155.221	155.855	170.768	166.453
180	-	-	169.192	190.077	175.521	171.63	183.552	190.728
200	-	-	200.412	205.214	196.97	194.643	194.176	205.007
225	-	-	227.661	217.533	216.906	220.098	229.968	216.872
250	-	-	245.792	257.672	245.99	246.994	263.505	256.847
280	-	-	-	292.708	-	271.994	283.223	294.304
315	-	-	-	316.018	-	308.463	-	316.338

SERIES G

RIGHT ANGLE SHAFT MECHANICAL RATINGS AT 1750 RPM INPUT

Nominal Ratio Column Entry	Nominal Output Speed RPM	Mechanical Capacity	RIGHT ANGLE SHAFT UNITS - SIZE								
			G14	G15	G16	G17	G18	G19	G21	G22	
8.0	219	Input power - HP	263	-	559	-	1240	-	-	-	TRIPLE REDUCTION
		Output torque -lb-in	70088	-	157522	-	341593	-	-	-	
9.0	194	Input power - HP	263	-	559	-	1240	-	2447	-	
		Output torque -lb-in	80796	-	170796	-	376991	-	783186	-	
10	175	Input power - HP	263	-	559	-	1240	-	2447	2447	
		Output torque -lb-in	89381	-	186726	-	432743	-	867257	878761	
11	159	Input power - HP	255	-	559	-	1240	-	2447	2447	
		Output torque -lb-in	95575	-	212389	-	481416	-	982301	973451	
12	146	Input power - HP	232	263	527	559	1224	1240	2426	2447	
		Output torque -lb-in	97345	112389	225664	239823	518584	542478	1061947	1097345	
14	125	Input power - HP	211	253	475	559	1093	1240	2293	2414	
		Output torque -lb-in	97345	120354	225664	273451	518584	603540	1123894	1194690	
16	109	Input power - HP	189	229	416	542	937	1240	2069	2280	
		Output torque -lb-in	97345	121239	225664	298230	518584	659292	1150442	1256637	
18	97.2	Input power - HP	169	208	366	503	852	1157	1825	2092	
		Output torque -lb-in	97345	122124	226549	307965	518584	688496	1150442	1300885	
20	87.5	Input power - HP	149	186	339	436	752	1006	1596	1891	
		Output torque -lb-in	97345	123894	226549	304425	518584	699115	1150442	1327434	
22	79.5	Input power - HP	112	166	282	393	632	915	1487	1743	
		Output torque -lb-in	84956	123894	212389	312389	496460	699115	1150442	1398230	
25	70.0	Input power - HP	112	148	267	366	603	809	1262	1636	
		Output torque -lb-in	93805	123894	226549	313274	518584	699115	1123894	1415929	
28	62.5	Input power - HP	117	112	240	282	539	632	1149	1255	
		Output torque -lb-in	97345	106195	226549	274336	518584	623894	1150442	1256637	
32	54.7	Input power - HP	94.1	112	211	282	461	613	1021	1208	
		Output torque -lb-in	97345	118584	226549	307080	518584	660177	1150442	1353982	
36	48.6	Input power - HP	83.9	103	185	253	420	579	900	1132	
		Output torque -lb-in	97345	122124	226549	309735	518584	699115	1150442	1424779	
40	43.8	Input power - HP	74.0	92.9	172	224	370	498	787	999	
		Output torque -lb-in	97345	123894	226549	311504	518584	700885	1150442	1424779	
45	38.9	Input power - HP	67.3	82.9	152	198	350	452	732	874	
		Output torque -lb-in	97345	123894	226549	312389	518584	700885	1150442	1424779	
50	35.0	Input power - HP	61.1	73.1	133	185	300	398	634	814	
		Output torque -lb-in	97345	123894	226549	313274	518584	700885	1150442	1424779	
56	31.3	Input power - HP	54.6	67.3	117	158	272	355	561	658	
		Output torque -lb-in	97345	123894	226549	305310	518584	660177	1150442	1327434	
63	27.8	Input power - HP	48.1	60.5	109	142	241	323	489	624	
		Output torque -lb-in	97345	123894	226549	311504	518584	700885	1150442	1424779	
71	24.6	Input power - HP	-	53.9	90.7	125	221	294	456	544	
		Output torque -lb-in	-	123894	226549	312389	518584	700885	1150442	1424779	
80	21.9	Input power - HP	-	47.6	84.1	117	194	260	402	507	
		Output torque -lb-in	-	123894	226549	313274	518584	700885	1150442	1424779	
90	19.4	Input power - HP	-	-	74.3	97.0	169	223	373	448	
		Output torque -lb-in	-	-	226549	313274	455752	655752	1150442	1433628	
100	17.5	Input power - HP	-	-	65.4	90.2	156	211	327	417	
		Output torque -lb-in	-	-	226549	313274	471681	701770	1150442	1433628	
112	15.6	Input power - HP	-	-	60.6	78.2	137	169	286	366	
		Output torque -lb-in	-	-	226549	307080	492035	640708	1150442	1433628	
125	14.0	Input power - HP	-	-	51.2	70.0	123	168	267	320	
		Output torque -lb-in	-	-	226549	313274	504425	701770	1150442	1433628	
140	12.5	Input power - HP	-	-	45.2	65.2	111	149	225	298	
		Output torque -lb-in	-	-	226549	313274	518584	701770	1150442	1433628	
160	10.9	Input power - HP	-	-	41.8	54.7	98.3	132	197	252	
		Output torque -lb-in	-	-	226549	311504	518584	701770	1150442	1433628	
180	9.72	Input power - HP	-	-	35.8	48.3	86.9	120	184	220	
		Output torque -lb-in	-	-	226549	312389	518584	701770	1150442	1433628	
200	8.75	Input power - HP	-	-	31.6	44.9	77.5	106	173	205	
		Output torque -lb-in	-	-	226549	313274	518584	701770	1150442	1433628	
225	7.78	Input power - HP	-	-	29.4	35.8	70.4	93.7	146	194	
		Output torque -lb-in	-	-	226549	265487	518584	701770	1150442	1433628	
250	7.00	Input power - HP	-	-	27.2	31.6	62.1	83.5	128	164	
		Output torque -lb-in	-	-	226549	278761	518584	701770	1150442	1433628	
280	6.25	Input power - HP	-	-	-	31.4	-	75.9	119	143	
		Output torque -lb-in	-	-	-	312389	-	701770	1150442	1433628	
315	5.56	Input power - HP	-	-	-	29.2	-	67.1	-	133	
		Output torque -lb-in	-	-	-	313274	-	701770	-	1433628	

TRIPLE REDUCTION

QUADRUPLE REDUCTION

Bold Text: Forced lubrication System Required

SERIES G

RIGHT ANGLE SHAFT MECHANICAL RATINGS AT 1450 RPM INPUT

Nominal Ratio Column Entry	Nominal Output Speed RPM	Mechanical Capacity	RIGHT ANGLE SHAFT UNITS - SIZE								
			G14	G15	G16	G17	G18	G19	G21	G22	
8.0	181	Input power - HP	231	-	489	-	1029	-	-	-	
		Output torque -lb-in	74336	-	167257	-	341593	-	-	-	
9.0	161	Input power - HP	223	-	489	-	1029	-	2012	-	
		Output torque -lb-in	83186	-	180531	-	376991	-	778761	-	
10	145	Input power - HP	217	-	489	-	1029	-	2012	2012	
		Output torque -lb-in	89381	-	197345	-	431858	-	858407	874336	
11	132	Input power - HP	211	-	489	-	1029	-	2012	2012	
		Output torque -lb-in	95575	-	224779	-	480531	-	973451	964602	
12	121	Input power - HP	193	217	439	500	1015	1029	2012	2012	
		Output torque -lb-in	97345	112389	225664	259292	518584	541593	1061947	1097345	
14	104	Input power - HP	174	209	393	489	907	1029	1920	2012	
		Output torque -lb-in	97345	119469	226549	289381	518584	602655	1141593	1194690	
16	90.6	Input power - HP	157	190	345	463	778	1029	1707	1998	
		Output torque -lb-in	97345	121239	226549	307080	518584	658407	1150442	1327434	
18	80.6	Input power - HP	139	172	304	417	707	974	1506	1837	
		Output torque -lb-in	97345	122124	226549	308850	518584	699115	1150442	1371681	
20	72.5	Input power - HP	123	154	282	369	625	835	1318	1649	
		Output torque -lb-in	97345	123894	226549	311504	518584	699115	1150442	1398230	
22	65.9	Input power - HP	92.8	138	248	326	546	760	1227	1475	
		Output torque -lb-in	84513	123894	209735	312389	517699	699115	1150442	1424779	
25	58.0	Input power - HP	92.8	122	221	303	500	672	1041	1368	
		Output torque -lb-in	94690	123894	226549	313274	518584	700000	1123894	1424779	
28	51.8	Input power - HP	86.8	92.8	198	248	447	546	947	1041	
		Output torque -lb-in	97345	106195	226549	289381	518584	648673	1150442	1247788	
32	45.3	Input power - HP	77.9	92.8	174	233	384	526	841	1002	
		Output torque -lb-in	97345	118584	226549	307080	518584	682301	1150442	1353982	
36	40.3	Input power - HP	69.5	85.7	153	211	347	481	743	940	
		Output torque -lb-in	97345	123894	226549	308850	518584	700000	1150442	1424779	
40	36.3	Input power - HP	61.4	77.0	142	186	401	413	649	830	
		Output torque -lb-in	97345	123894	226549	311504	518584	700885	1150442	1424779	
45	32.2	Input power - HP	55.8	68.7	126	165	290	374	605	725	
		Output torque -lb-in	97345	123894	226549	312389	518584	692035	1150442	1424779	
50	29.0	Input power - HP	50.7	60.6	110	153	248	331	524	676	
		Output torque -lb-in	97345	123894	226549	313274	518584	700885	1150442	1424779	
56	25.9	Input power - HP	45.2	55.8	97.1	133	227	295	463	546	
		Output torque -lb-in	97345	123894	226549	309735	518584	663717	1150442	1327434	
63	23.0	Input power - HP	40.0	50.0	90.0	118	200	268	404	516	
		Output torque -lb-in	97345	123894	226549	311504	518584	700885	1150442	1424779	
71	20.4	Input power - HP	-	44.7	75.1	104	182	244	375	452	
		Output torque -lb-in	-	123894	226549	311504	518584	700885	1150442	1433628	
80	18.1	Input power - HP	-	39.4	69.6	96.7	161	215	333	420	
		Output torque -lb-in	-	123894	226549	312389	518584	701770	1150442	1433628	
90	16.1	Input power - HP	-	-	61.6	80.3	142	194	310	371	
		Output torque -lb-in	-	-	226549	312389	482301	693805	1150442	1433628	
100	14.5	Input power - HP	-	-	54.2	74.8	129	174	271	346	
		Output torque -lb-in	-	-	226549	313274	499115	701770	1150442	1433628	
112	12.9	Input power - HP	-	-	50.3	65.7	114	143	237	304	
		Output torque -lb-in	-	-	226549	311504	518584	657522	1150442	1433628	
125	11.6	Input power - HP	-	-	42.5	57.9	102	139	221	266	
		Output torque -lb-in	-	-	226549	312389	518584	701770	1150442	1433628	
140	10.4	Input power - HP	-	-	37.4	53.9	92.3	123	186	247	
		Output torque -lb-in	-	-	226549	313274	518584	701770	1150442	1433628	
160	9.06	Input power - HP	-	-	34.7	45.3	81.4	110	164	209	
		Output torque -lb-in	-	-	226549	311504	518584	701770	1150442	1433628	
180	8.06	Input power - HP	-	-	29.6	40.0	72.0	100	152	182	
		Output torque -lb-in	-	-	226549	312389	518584	701770	1150442	1433628	
200	7.25	Input power - HP	-	-	26.3	37.3	64.2	87.8	143	170	
		Output torque -lb-in	-	-	226549	313274	518584	701770	1150442	1433628	
225	6.44	Input power - HP	-	-	24.3	29.6	58.3	77.6	121	161	
		Output torque -lb-in	-	-	226549	265487	518584	701770	1150442	1433628	
250	5.80	Input power - HP	-	-	22.5	26.3	51.5	69.2	106	135	
		Output torque -lb-in	-	-	226549	278761	518584	701770	1150442	1433628	
280	5.18	Input power - HP	-	-	-	26.0	-	62.9	98.6	119	
		Output torque -lb-in	-	-	-	312389	-	701770	1150442	1433628	
315	4.60	Input power - HP	-	-	-	24.1	-	55.5	-	110	
		Output torque -lb-in	-	-	-	313274	-	701770	-	1433628	

TRIPLE REDUCTION

QUADRUPLE REDUCTION

Bold Text: Forced lubrication System Required

SERIES G

RIGHT ANGLE SHAFT MECHANICAL RATINGS AT 1160 RPM INPUT

Nominal Ratio Column Entry	Nominal Output Speed RPM	Mechanical Capacity	RIGHT ANGLE SHAFT UNITS - SIZE								
			G14	G15	G16	G17	G18	G19	G21	G22	
8.0	145	Input power - HP	185	-	401	-	822	-	-	-	
		Output torque -lb-in	74779	-	170796	-	340708	-	-	-	
9.0	129	Input power - HP	178	-	401	-	822	-	1609	-	
		Output torque -lb-in	83009	-	184071	-	376106	-	778761	-	
10	116	Input power - HP	174	-	401	-	822	-	1609	1609	
		Output torque -lb-in	89381	-	200885	-	430973	-	858407	872566	
11	105	Input power - HP	169	-	394	-	822	-	1609	1609	
		Output torque -lb-in	95575	-	226549	-	479646	-	973451	964602	
12	96.7	Input power - HP	154	174	351	401	814	822	1609	1609	
		Output torque -lb-in	97345	112389	226549	259292	518584	540708	1061947	1088496	
14	82.9	Input power - HP	139	168	315	398	725	822	1539	1609	
		Output torque -lb-in	97345	119469	226549	293805	518584	601770	1141593	1194690	
16	72.5	Input power - HP	125	153	276	370	622	822	1368	1609	
		Output torque -lb-in	97345	121239	226549	307080	516814	657522	1150442	1336283	
18	64.4	Input power - HP	112	138	244	334	566	782	1207	1529	
		Output torque -lb-in	97345	122124	226549	309735	518584	699115	1150442	1424779	
20	58.0	Input power - HP	98.6	121	225	295	500	671	1055	1341	
		Output torque -lb-in	97345	123894	226549	311504	518584	700000	1150442	1424779	
22	52.7	Input power - HP	74.2	110	198	261	437	609	983	1177	
		Output torque -lb-in	84513	123894	223894	312389	518584	700000	1150442	1424779	
25	46.4	Input power - HP	74.2	97.4	177	243	401	538	833	1097	
		Output torque -lb-in	93805	123894	226549	313274	518584	700000	1123894	1424779	
28	41.4	Input power - HP	69.5	74.2	160	198	358	437	759	833	
		Output torque -lb-in	97345	106195	226549	292035	518584	648673	1150442	1247788	
32	36.3	Input power - HP	62.4	74.2	139	186	306	421	675	802	
		Output torque -lb-in	97345	118584	226549	307080	518584	682301	1150442	1345133	
36	32.2	Input power - HP	55.7	68.5	123	169	279	385	595	754	
		Output torque -lb-in	97345	122124	226549	309735	518584	700885	1150442	1424779	
40	29.0	Input power - HP	49.1	61.6	114	149	245	330	520	665	
		Output torque -lb-in	97345	123894	226549	311504	518584	700885	1150442	1424779	
45	25.8	Input power - HP	44.7	54.8	101	131	232	300	484	582	
		Output torque -lb-in	97345	123894	226549	312389	518584	700885	1150442	1424779	
50	23.2	Input power - HP	40.5	48.5	88.2	122	198	264	420	542	
		Output torque -lb-in	97345	123894	226549	313274	518584	700885	1150442	1424779	
56	20.7	Input power - HP	36.2	44.5	77.6	106	181	236	370	436	
		Output torque -lb-in	97345	123894	226549	309735	518584	663717	1150442	1327434	
63	18.4	Input power - HP	31.9	40.1	72.0	94.1	160	215	323	413	
		Output torque -lb-in	97345	123894	226549	311504	518584	700885	1150442	1433628	
71	16.3	Input power - HP	-	35.7	60.1	83.1	146	194	300	361	
		Output torque -lb-in	-	123894	226549	312389	518584	700885	1150442	1433628	
80	14.5	Input power - HP	-	31.5	55.7	77.4	129	172	266	337	
		Output torque -lb-in	-	123894	226549	313274	518584	701770	1150442	1433628	
90	12.9	Input power - HP	-	-	49.2	64.2	114	158	248	298	
		Output torque -lb-in	-	-	226549	312389	515929	701770	1150442	1433628	
100	11.6	Input power - HP	-	-	43.3	59.8	103	139	217	278	
		Output torque -lb-in	-	-	226549	313274	518584	701770	1150442	1433628	
112	10.4	Input power - HP	-	-	40.2	52.6	91.1	119	189	243	
		Output torque -lb-in	-	-	226549	311504	518584	681416	1150442	1433628	
125	9.28	Input power - HP	-	-	33.9	46.4	81.3	111	177	212	
		Output torque -lb-in	-	-	226549	312389	518584	701770	1150442	1433628	
140	8.29	Input power - HP	-	-	29.9	43.2	73.8	98.3	149	197	
		Output torque -lb-in	-	-	226549	313274	518584	701770	1150442	1433628	
160	7.25	Input power - HP	-	-	27.8	36.2	65.2	87.6	130	168	
		Output torque -lb-in	-	-	226549	311504	518584	701770	1150442	1433628	
180	6.44	Input power - HP	-	-	23.7	32.0	57.5	79.5	121	146	
		Output torque -lb-in	-	-	207965	312389	518584	701770	1150442	1433628	
200	5.80	Input power - HP	-	-	21.1	29.8	51.4	70.3	115	135	
		Output torque -lb-in	-	-	216814	313274	518584	701770	1150442	1433628	
225	5.16	Input power - HP	-	-	19.4	23.7	46.7	62.1	97.0	128	
		Output torque -lb-in	-	-	226549	265487	518584	701770	1150442	1433628	
250	4.64	Input power - HP	-	-	18.0	21.1	41.2	55.4	84.6	109	
		Output torque -lb-in	-	-	226549	278761	518584	701770	1150442	1433628	
280	4.14	Input power - HP	-	-	-	20.8	-	50.3	78.9	94.8	
		Output torque -lb-in	-	-	-	312389	-	701770	1150442	1433628	
315	3.68	Input power - HP	-	-	-	19.4	-	44.4	-	88.4	
		Output torque -lb-in	-	-	-	313274	-	701770	-	1433628	

TRIPLE REDUCTION

QUADRUPLE REDUCTION

SERIES G

RIGHT ANGLE SHAFT MECHANICAL RATINGS AT 875 RPM INPUT

Nominal Ratio Column Entry	Nominal Output Speed RPM	Mechanical Capacity	RIGHT ANGLE SHAFT UNITS - SIZE								
			G14	G15	G16	G17	G18	G19	G21	G22	
8.0	109	Input power - HP	139	-	302	-	620	-	-	-	
		Output torque -lb-in	74779	-	169912	-	339823	-	-	-	
9.0	97.2	Input power - HP	134	-	302	-	620	-	1216	-	
		Output torque -lb-in	83009	-	184071	-	375221	-	778761	-	
10	87.5	Input power - HP	131	-	302	-	620	-	1216	1218	
		Output torque -lb-in	89381	-	200885	-	430088	-	858407	870796	
11	79.5	Input power - HP	127	-	298	-	620	-	1216	1218	
		Output torque -lb-in	95575	-	226549	-	479646	-	973451	964602	
12	72.9	Input power - HP	116	131	266	302	614	620	1216	1218	
		Output torque -lb-in	97345	112389	226549	258407	518584	539823	1061947	1088496	
14	62.5	Input power - HP	105	126	239	300	547	620	1161	1218	
		Output torque -lb-in	97345	119469	226549	293805	518584	601770	1141593	1194690	
16	54.7	Input power - HP	94.5	115	209	280	471	620	1033	1218	
		Output torque -lb-in	97345	121239	226549	307080	518584	656637	1150442	1336283	
18	48.6	Input power - HP	84.2	104	184	252	428	589	912	1153	
		Output torque -lb-in	97345	122124	226549	308850	518584	700000	1150442	1424779	
20	43.8	Input power - HP	74.3	93.2	170	223	378	506	797	1018	
		Output torque -lb-in	97345	123894	226549	311504	518584	700000	1150442	1424779	
22	39.8	Input power - HP	55.9	83.1	149	197	329	460	742	890	
		Output torque -lb-in	84513	123894	226549	312389	518584	700000	1150442	1424779	
25	35.0	Input power - HP	55.9	73.5	133	184	302	406	628	830	
		Output torque -lb-in	94690	123894	226549	313274	518584	700885	1115044	1424779	
28	31.3	Input power - HP	52.3	55.9	120	149	270	329	573	629	
		Output torque -lb-in	97345	106195	226549	292035	518584	650442	1150442	1247788	
32	27.3	Input power - HP	47.1	55.9	105	141	231	318	510	605	
		Output torque -lb-in	97345	118584	226549	307080	518584	682301	1150442	1345133	
36	24.3	Input power - HP	42.0	51.8	92.7	127	211	291	449	570	
		Output torque -lb-in	97345	123894	226549	308850	518584	700885	1150442	1424779	
40	21.9	Input power - HP	37.0	46.4	85.8	112	186	249	393	503	
		Output torque -lb-in	97345	123894	226549	311504	518584	700885	1150442	1424779	
45	19.4	Input power - HP	33.7	41.4	75.9	99.1	174	227	366	440	
		Output torque -lb-in	97345	123894	226549	312389	518584	700885	1150442	1433628	
50	17.5	Input power - HP	30.6	36.6	66.5	92.3	150	200	316	409	
		Output torque -lb-in	97345	123894	226549	313274	518584	701770	1150442	1433628	
56	15.6	Input power - HP	27.2	33.7	58.7	80.3	137	177	279	329	
		Output torque -lb-in	97345	123894	226549	309735	518584	663717	1150442	1327434	
63	13.9	Input power - HP	24.1	30.2	54.3	71.1	120	161	244	312	
		Output torque -lb-in	97345	123894	226549	311504	518584	700885	1150442	1433628	
71	12.3	Input power - HP	-	27.0	45.3	62.8	110	146	227	272	
		Output torque -lb-in	-	123894	226549	312389	518584	701770	1150442	1433628	
80	10.9	Input power - HP	-	23.9	42.1	58.3	97.5	130	201	253	
		Output torque -lb-in	-	123894	226549	313274	518584	70177	1150442	1433628	
90	9.72	Input power - HP	-	-	37.1	48.5	85.7	119	186	224	
		Output torque -lb-in	-	-	226549	312389	518584	701770	1150442	1433628	
100	8.75	Input power - HP	-	-	32.7	45.1	77.9	105	164	209	
		Output torque -lb-in	-	-	226549	313274	518584	701770	1150442	1433628	
112	7.81	Input power - HP	-	-	30.3	39.6	68.7	92.4	143	184	
		Output torque -lb-in	-	-	226549	312389	518584	701770	1150442	1433628	
125	7.00	Input power - HP	-	-	25.6	35.0	61.3	83.9	133	160	
		Output torque -lb-in	-	-	226549	312389	518584	701770	1150442	1433628	
140	6.25	Input power - HP	-	-	22.7	32.5	55.7	74.0	113	149	
		Output torque -lb-in	-	-	226549	313274	518584	701770	1150442	1433628	
160	5.47	Input power - HP	-	-	20.9	27.4	49.1	66.1	98.3	126	
		Output torque -lb-in	-	-	226549	313274	518584	701770	1150442	1433628	
180	4.86	Input power - HP	-	-	17.8	24.1	43.4	60.1	91.6	110	
		Output torque -lb-in	-	-	207965	313274	518584	701770	1150442	1433628	
200	4.38	Input power - HP	-	-	15.8	22.5	38.8	53.1	86.5	103	
		Output torque -lb-in	-	-	216814	313274	518584	701770	1150442	1433628	
225	3.89	Input power - HP	-	-	14.6	17.8	35.3	46.8	73.1	96.8	
		Output torque -lb-in	-	-	227434	265487	518584	701770	1150442	1433628	
250	3.50	Input power - HP	-	-	13.5	15.8	31.1	41.8	63.8	81.9	
		Output torque -lb-in	-	-	227434	278761	518584	701770	1150442	1433628	
280	3.13	Input power - HP	-	-	-	15.7	-	38.0	59.4	72.5	
		Output torque -lb-in	-	-	-	313274	-	701770	1150442	1451327	
315	2.78	Input power - HP	-	-	-	16.0	-	33.5	-	67.6	
		Output torque -lb-in	-	-	-	313274	-	701770	-	1451327	

TRIPLE REDUCTION

QUADRUPLE REDUCTION

SERIES G

RIGHT ANGLE SHAFT

THERMAL RATINGS

Thermal Ratings HP

These thermal ratings assume the gear unit is in constant use working in an ambient temperature of 77°F (25°C)* installed in a large indoor space at sea level.

These ratings must be adjusted for alternative operating and environment conditions refer to Thermal ratings and service factors on page 6. Ratings are for reference purposes. Contact Application Engineering to confirm suitability for your application.

*maximum bulk oil temperature 203°F (95°C)

Right Angle Shaft Units - Triple Reduction

Type of Cooling	Input Speed (rev/min)	Ratio	G1430	G1530	G1630	G1730	G1830	G1930	G2130	G2230
No Additional Cooling	1750	12:1	89	96	143	136	223	196	236	250
		25:1	67	77	119	116	186	166	207	222
		56:1	41	50	82	84	130	119	156	173
	1450	12:1	86	93	143	139	230	215	279	295
		25:1	66	75	120	120	194	185	248	265
		56:1	41	50	84	88	138	136	192	212
	1160	12:1	84	89	143	141	236	231	315	331
		25:1	66	73	121	122	201	201	283	301
		56:1	42	50	86	91	145	151	224	244
	875	12:1	82	86	141	140	236	238	333	349
		25:1	64	71	120	123	202	208	300	319
		56:1	41	49	86	92	148	158	240	262
Fan Cooling	1750	12:1	240	243	386	382	650	725	1024	1053
		25:1	206	216	350	354	592	674	968	1003
		56:1	149	167	282	296	479	568	850	897
	1450	12:1	212	215	347	345	584	655	933	962
		25:1	181	190	314	318	530	606	880	915
		56:1	129	145	250	264	425	508	768	813
	1160	12:1	185	188	308	307	520	586	843	871
		25:1	157	165	277	282	469	540	792	825
		56:1	111	125	219	232	373	449	687	729
	875	12:1	163	167	277	277	467	529	767	794
		25:1	137	146	248	253	420	486	719	751
		56:1	96	109	194	207	332	401	620	660
Cooling Coil	1750	12:1	233	242	377	379	634	642	743	768
		25:1	199	215	342	350	576	592	692	722
		56:1	142	165	275	293	465	492	588	627
	1450	12:1	226	234	371	374	626	640	755	780
		25:1	194	209	337	346	570	591	705	736
		56:1	140	162	272	291	462	493	602	642
	1160	12:1	219	227	365	369	619	638	765	792
		25:1	189	203	332	342	564	590	716	748
		56:1	137	158	269	288	459	495	616	655
	875	12:1	212	220	356	361	605	627	761	788
		25:1	183	196	324	335	552	581	713	745
		56:1	133	153	263	283	451	489	615	654
Fan and Cooling Coil	1750	12:1	333	338	535	535	913	988	1297	1330
		25:1	296	309	497	505	849	932	1238	1278
		56:1	227	252	420	441	719	815	1110	1164
	1450	12:1	309	314	503	504	858	929	1218	1251
		25:1	274	287	466	475	797	875	1161	1201
		56:1	209	233	392	413	672	762	1038	1090
	1160	12:1	286	291	471	474	804	871	1141	1173
		25:1	252	265	436	446	745	819	1085	1124
		56:1	192	214	364	386	626	710	966	1017
	875	12:1	266	272	442	446	755	818	1070	1102
		25:1	234	246	409	419	699	768	1017	1055
		56:1	177	199	341	362	586	664	903	952

Right Angle Shafts - Quadruple Reduction

Type of Cooling	Input Speed (rev/min)	Ratio	G1440	G1540	G1640	G1740	G1840	G1940	G2140	G2240
No Additional Cooling	1750	100:1	-	-	83	82	111	100	123	125
		250:1	-	-	60	61	85	79	97	102
	1450	100:1	-	-	82	82	115	109	146	148
		250:1	-	-	60	63	89	88	117	123
	1160	100:1	-	-	82	82	119	118	165	167
		250:1	-	-	61	64	93	97	135	140
	875	100:1	-	-	80	82	119	121	175	176
		250:1	-	-	60	64	94	100	144	149

SERIES G

DIMENSIONS HORIZONTAL RIGHT ANGLE SHAFTS TRIPLE REDUCTION

G **B**

Triple Reduction Right Angle Units Horizontal

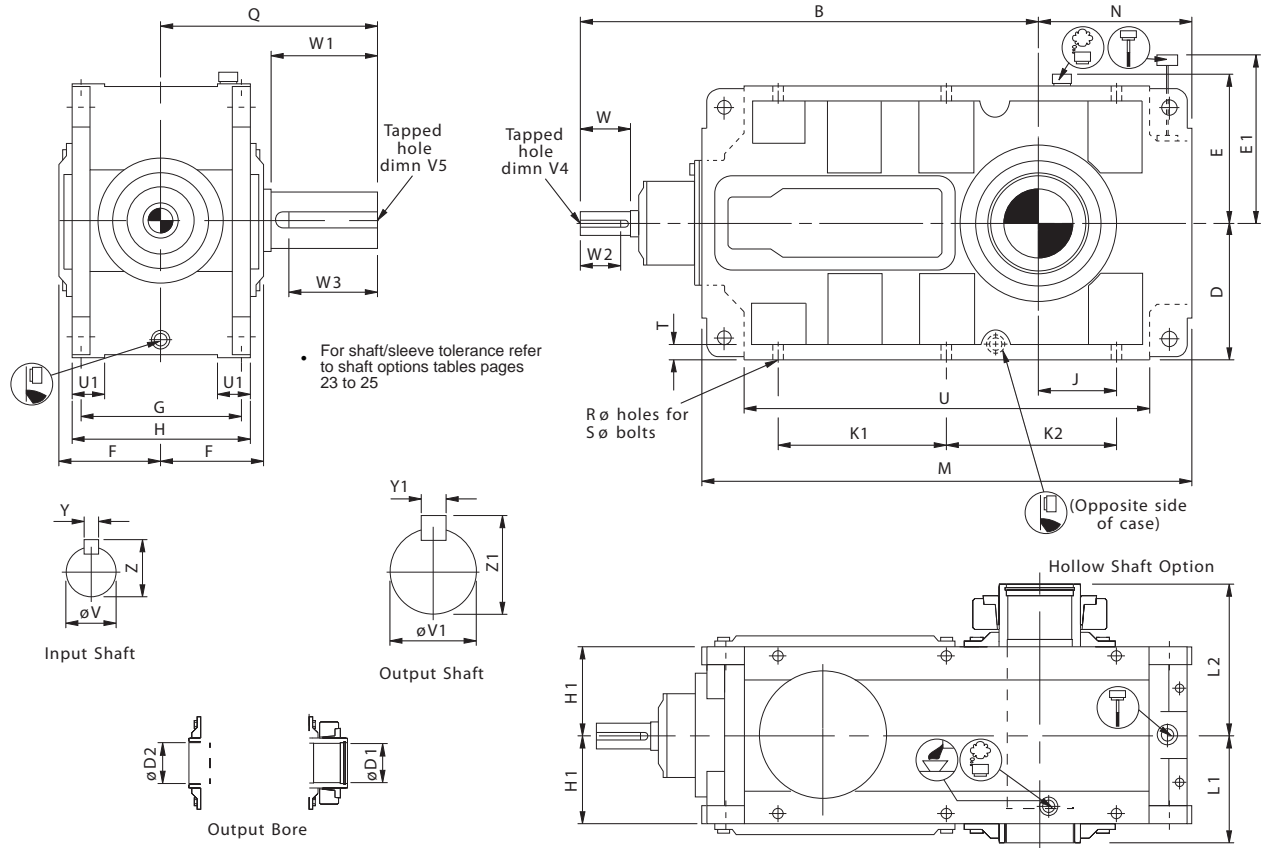

Unit Size	B	D	E	E1	F	G	H	H1	J	K1	K2	M	N	Q	R	S	T	U	U1
G14	28.35	9.06	9.84	14.57	6.97	10.43	11.81	5.91	6.69	11.22		32.28	11.61	14.17	0.73	6 x m16 x 60*	0.98	26.93	2.17
G15	29.92	9.06	9.84	14.57	6.97	10.43	11.81	5.91	5.12	11.22		32.28	10.04	14.57	0.73	6 x m16 x 60*	0.98	26.93	2.17
G16	37.01	11.81	13.19	20.28	8.86	12.99	14.96	7.48	8.86	15.16		41.73	14.57	18.11	1.10	6 X m24 X 80*	1.18	35.35	2.76
G17	39.17	11.81	13.19	20.28	8.86	12.99	14.96	7.48	6.69	15.16		41.73	12.40	18.90	1.10	6 X m24 X 80*	1.18	35.35	2.76
G18	48.03	15.16	16.54	27.95	11.42	17.32	19.69	9.84	6.02	20.47	13.78	48.82	13.31	23.62	1.30	6 x m30 x 100*	1.46	40.79	3.54
G19	50.59	15.16	16.54	27.95	11.42	17.32	19.69	9.84	8.66	19.69		54.09	16.02	25.59	1.30	6 x m30 x 100*	1.57	46.06	3.54
G21	64.17	18.31	19.96	29.53	13.39	20.87	23.62	11.81	8.86	27.36	18.90	65.16	18.31	27.56	1.54	6 x m36 x 100*	1.97	54.33	4.72
G22	65.75	18.31	19.96	29.53	13.39	20.87	23.62	11.81	9.65	29.33	19.29	67.52	19.09	28.74	1.54	6 x m36 x 100*	1.97	56.69	4.72

Unit Size	Input Shaft						Output Shaft						Output Bore			
	V	V4	W	W2	Y	Z	V1	V5	W1	W3	Y1	Z1	D1	D2	L1	L2
G14	1.500	5/8 UNF x 1.25	3.94	3.00	0.313	1.60	4.500	1 UNF x 2	7.09	6.50	1.00	4.94	3.74	3.94	7.09	10.04
G15	1.500	5/8 UNF x 1.25	3.94	3.00	0.313	1.60	5.000	1 UNF x 2	7.48	7.13	1.25	5.55	4.33	4.53	7.09	10.24
G16	1.875	5/8 UNF x 1.25	5.51	4.13	0.500	2.10	6.000	1.25 UNF x 2.5	9.06	8.75	1.50	6.66	4.92	5.12	9.06	12.80
G17	1.875	5/8 UNF x 1.25	5.51	4.13	0.500	2.10	6.750	1.25 UNF x 2.5	9.84	9.38	1.75	7.39	5.71	5.91	9.06	13.39
G18	3.000	3/4 UNF x 1.62	6.30	5.25	0.750	3.33	7.500	1.5 UNF x 3	11.81	11.38	1.75	8.15	6.30	6.69	11.81	16.14
G19	3.000	3/4 UNF x 1.62	6.30	5.25	0.750	3.33	8.250	1.5 UNF x 3	13.78	13.00	2.00	8.88	6.69	7.09	11.81	16.93
G21	4.000	1 UNF x 2	8.27	7.50	1.000	4.44	8.500	1.5 UNF x 3	13.78	13.00	2.00	9.13	8.27	8.66	13.78	19.69
G22	4.000	1 UNF x 2	8.27	7.50	1.000	4.44	9.250	1.5 UNF x 3	14.96	14.25	2.50	9.95	9.06	9.45	13.78	20.28

SERIES G DIMENSIONS VERTICAL RIGHT ANGLE SHAFTS TRIPLE REDUCTION

G **3** **0** **R**

Triple Reduction Right Angle Units Vertical

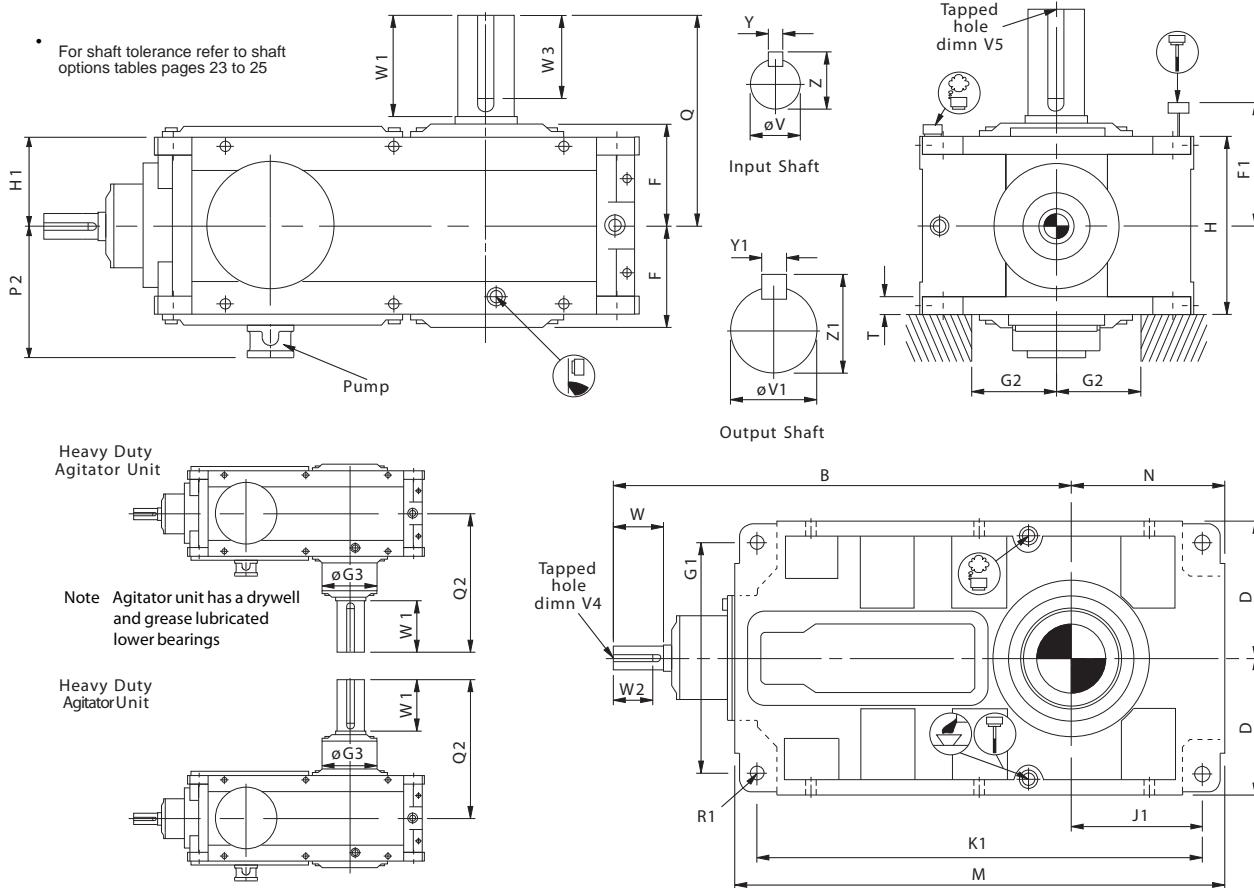

Unit Size	B	D	F	F1	G1	G2 (min)		G3	H	H1	J1	K1	M	N	P2	Q	Q2	R1	T
						No Fan	With Fan												
G14	28.35	9.06	6.97	15.35	15.35	5.31	6.10	9.06	11.81	5.91	10.24	29.53	32.28	11.61	9.29	14.17	18.70	4 x Ø24	1.18
G15	29.92	9.06	6.97	15.35	15.35	5.31	6.10	10.24	11.81	5.91	8.66	29.53	32.28	10.04	9.29	14.57	19.49	4 x Ø24	1.18
G16	37.01	11.81	8.86	20.28	19.92	6.89	8.07	11.81	14.96	7.48	12.80	38.19	41.73	14.57	11.22	18.11	23.43	4 x Ø33	1.77
G17	39.17	11.81	8.86	20.28	19.92	6.89	8.07	13.39	14.96	7.48	10.63	38.19	41.73	12.40	11.22	18.90	24.21	4 x Ø33	1.77
G18	48.03	15.16	11.42	27.56	25.83	8.07	9.65	14.57	19.69	9.84	11.06	44.33	48.82	13.31	13.58	23.62	29.92	4 x Ø40	2.17
G19	50.59	15.16	11.42	27.56	25.83	8.07	9.65	15.75	19.69	9.84	13.78	49.61	54.09	16.02	13.58	25.59	32.09	4 x Ø40	2.17
G21	64.17	18.31	13.39	29.53	31.10	10.04	12.40	19.69	23.62	11.81	15.55	59.65	65.16	18.31	15.75	27.56	36.42	4 x Ø48	2.76
G22	65.75	18.31	13.39	29.53	31.10	10.43	12.40	*	23.62	11.81	16.34	62.01	67.52	19.09	15.75	28.74	*	4 x Ø48	2.76

Unit Size	Input Shaft						Output Shaft					
	V	V4	W	W2	Y	Z	V1	V5	W1	W3	Y1	Z1
G14	1.500	5/8 UNF x 1.25	3.94	3.00	0.313	1.60	4.500	1 UNF x 2	7.09	6.50	1.00	4.94
G15	1.500	5/8 UNF x 1.25	3.94	3.00	0.313	1.60	5.000	1 UNF x 2	7.48	7.13	1.25	5.55
G16	1.875	5/8 UNF x 1.25	5.51	4.13	0.500	2.10	6.000	1.25 UNF x 2.5	9.06	8.75	1.50	6.66
G17	1.875	5/8 UNF x 1.25	5.51	4.13	0.500	2.10	6.750	1.25 UNF x 2.5	9.84	9.38	1.75	7.39
G18	3.000	3/4 UNF x 1.62	6.30	5.25	0.750	3.33	7.500	1.5 UNF x 3	11.81	11.38	1.75	8.15
G19	3.000	3/4 UNF x 1.62	6.30	5.25	0.750	3.33	8.250	1.5 UNF x 3	13.78	13.00	2.00	8.88
G21	4.000	1 UNF x 2	8.27	7.50	1.000	4.44	8.500	1.5 UNF x 3	13.78	13.00	2.00	9.13
G22	4.000	1 UNF x 2	8.27	7.50	1.000	4.44	9.250	1.5 UNF x 3	14.96	14.25	2.50	9.95

SERIES G

DIMENSIONS HORIZONTAL RIGHT ANGLE SHAFTS QUADRUPLE REDUCTION

G **40** **B**

Quadruple Reduction Right Angle Units Horizontal

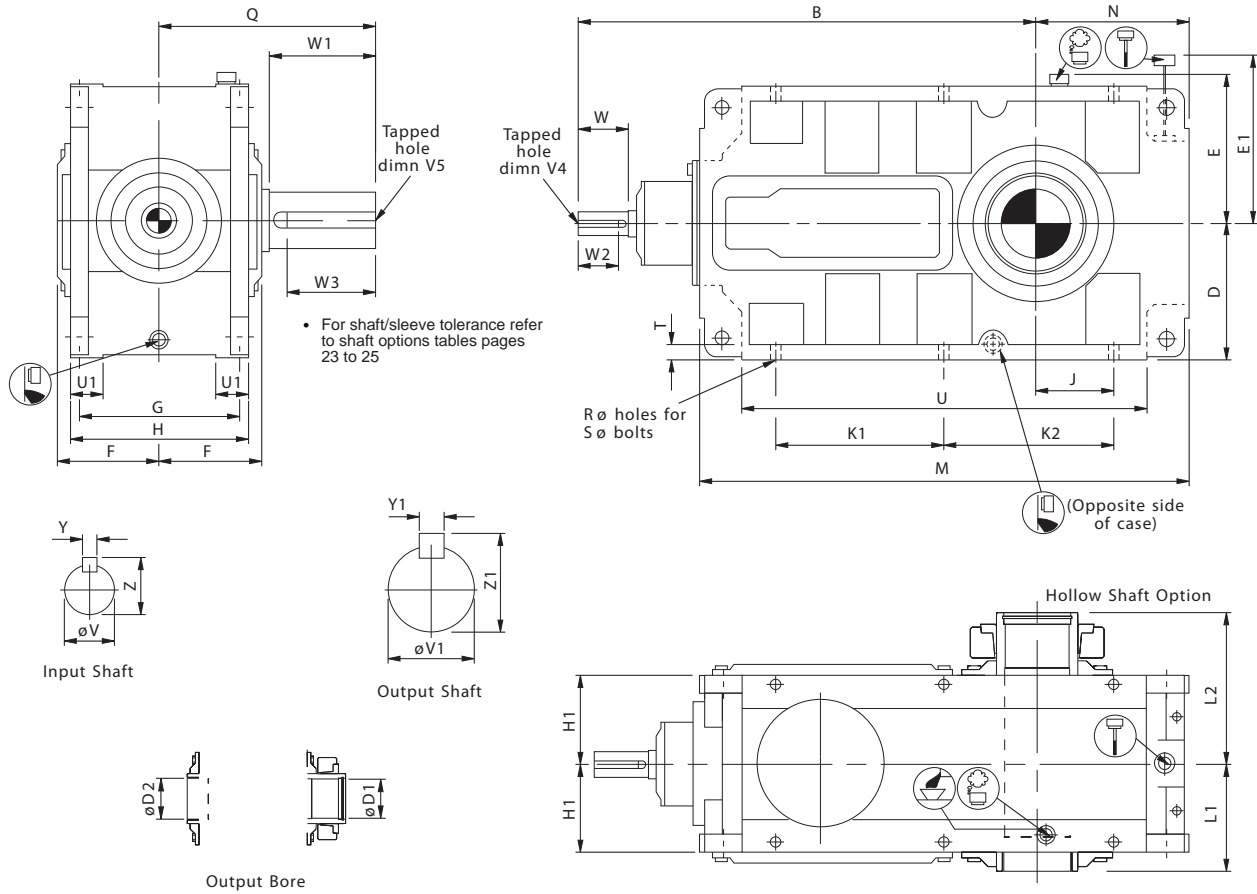

Unit Size	B	D	E	E1	F	G	H	H1	J	K1	K2	M	N	Q	R	S	T	U	U1
G16	37.99	11.81	13.19	20.28	8.86	12.99	14.96	7.48	8.86	15.16	0.00	41.73	14.57	18.11	1.10	6 x M24 x 80*	1.18	35.35	2.76
G17	40.16	11.81	13.19	20.28	8.86	12.99	14.96	7.48	6.69	15.16	0.00	41.73	12.40	18.90	1.10	6 x M24 x 80*	1.18	35.35	2.76
G18	49.80	15.16	16.54	27.95	11.42	17.32	19.69	9.84	6.02	20.47	13.78	48.82	13.31	23.62	1.30	6 x M30 x 100*	1.46	40.79	3.54
G19	52.36	15.16	16.54	27.95	11.42	17.32	19.69	9.84	8.66	19.69	19.69	54.09	16.02	25.59	1.30	6 x M30 x 100*	1.57	46.06	3.54
G21	65.35	18.31	19.96	29.53	13.39	20.87	23.62	11.81	8.86	27.36	18.90	65.16	18.31	27.56	1.54	6 x M36 x 100*	1.97	54.33	4.72
G22	66.93	18.31	19.96	29.53	13.39	20.87	23.62	11.81	9.65	29.33	19.29	67.52	19.09	28.74	1.54	6 x M36 x 100*	1.97	5.51	4.72

Unit Size	Input Shaft						Output Shaft						Output Bore			
	V	V4	W	W2	Y	Z	V1	V5	W1	W3	Y1	Z1	D1	D2	L1	L2
G16	1.500	5/8 UNF x 1.25	3.94	3.00	0.313	1.60	6.000	1.25 UNF x 2.5	9.06	8.75	1.50	6.66	4.92	5.12	9.06	12.80
G17	1.500	5/8 UNF x 1.25	3.94	3.00	0.313	1.60	6.750	1.25 UNF x 2.5	9.84	9.38	1.75	7.39	5.71	5.91	9.06	13.39
G18	1.875	5/8 UNF x 1.25	5.51	4.13	0.500	2.10	7.500	1.5 UNF x 3	11.81	11.38	1.75	8.15	6.30	6.69	11.81	16.14
G19	1.875	5/8 UNF x 1.25	5.51	4.13	0.500	2.10	8.250	1.5 UNF x 3	13.78	13.00	2.00	8.88	6.69	7.09	11.81	16.93
G21	3.000	3/4 UNF x 1.62	6.30	5.25	0.750	3.33	8.500	1.5 UNF x 3	13.78	13.00	2.00	9.13	8.27	8.66	13.78	19.69
G22	3.000	3/4 UNF x 1.62	6.30	5.25	0.750	3.33	9.250	1.5 UNF x 3	14.96	14.25	2.50	9.95	9.06	9.45	13.78	20.28

SERIES G

DIMENSIONS VERTICAL RIGHT ANGLE SHAFTS QUADRUPLE REDUCTION

G | **4 0** | **R**

Quadruple Reduction Right Angle Units Vertical

For shaft tolerance refer to shaft options tables pages 23 to 25

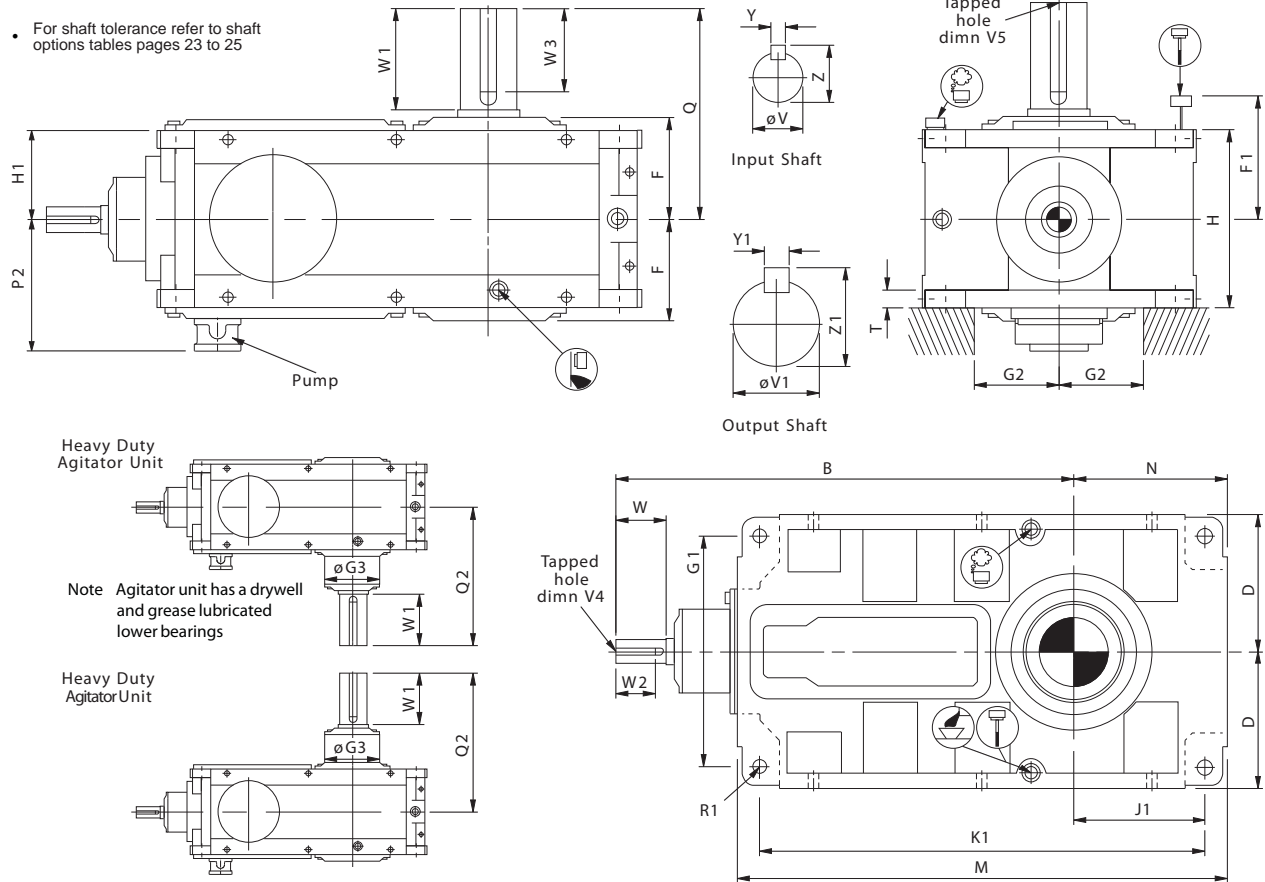

Unit Size	B	D	F	F1	G1	G2 (min)	G3	H	H1	J1	K1	M	N	P2	Q	Q2	R1	T
G16	37.99	11.81	8.86	20.28	19.92	6.89	11.81	14.96	7.48	12.80	38.19	41.73	14.57	11.22	18.11	23.43	4 x Ø33	1.77
G17	40.16	11.81	8.86	20.28	19.92	6.89	13.39	14.96	7.48	10.63	38.19	41.73	12.40	11.22	18.90	24.21	4 x Ø33	1.77
G18	49.80	15.16	11.42	27.56	25.83	8.07	14.57	19.69	9.84	11.06	44.33	48.82	13.31	13.58	23.62	29.92	4 x Ø40	2.17
G19	52.36	15.16	11.42	27.56	25.83	8.07	15.75	19.69	9.84	13.78	49.61	54.09	16.02	13.58	25.59	32.09	4 x Ø40	2.17
G21	65.35	18.31	13.39	29.53	31.10	10.04	19.69	23.62	11.81	15.55	59.65	65.16	18.31	15.75	27.56	36.42	4 x Ø48	2.76
G22	66.93	18.31	13.39	29.53	31.10	10.43	*	23.62	11.81	16.34	62.01	67.52	19.09	15.75	28.74	*	4 x Ø48	2.76

Unit Size	Input Shaft							Output Shaft					
	V	V4	W	W2	Y	Z	V1	V5	W1	W3	Y1	Z1	
G16	1.500	5/8 UNF x 1.25	3.94	3.00	0.313	1.60	6.000	1.25 UNF x 2.5	9.06	8.75	1.50	6.66	
G17	1.500	5/8 UNF x 1.25	3.94	3.00	0.313	1.60	6.750	1.25 UNF x 2.5	9.84	9.38	1.75	7.39	
G18	1.875	5/8 UNF x 1.25	5.51	4.13	0.500	2.10	7.500	1.5 UNF x 3	11.81	11.38	1.75	8.15	
G19	1.875	5/8 UNF x 1.25	5.51	4.13	0.500	2.10	8.250	1.5 UNF x 3	13.78	13.00	2.00	8.88	
G21	3.000	3/4 UNF x 1.62	6.30	5.25	0.750	3.33	8.500	1.5 UNF x 3	13.78	13.00	2.00	9.13	
G22	3.000	3/4 UNF x 1.62	6.30	5.25	0.750	3.33	9.250	1.5 UNF x 3	14.96	14.25	2.50	9.95	

SERIES G

DIMENSIONS HORIZONTAL 'J' TYPE

RIGHT ANGLE SHAFTS TRIPLE REDUCTION

G **3 0** **B**

Triple Reduction 'J' Type Right Angle Units Vertical

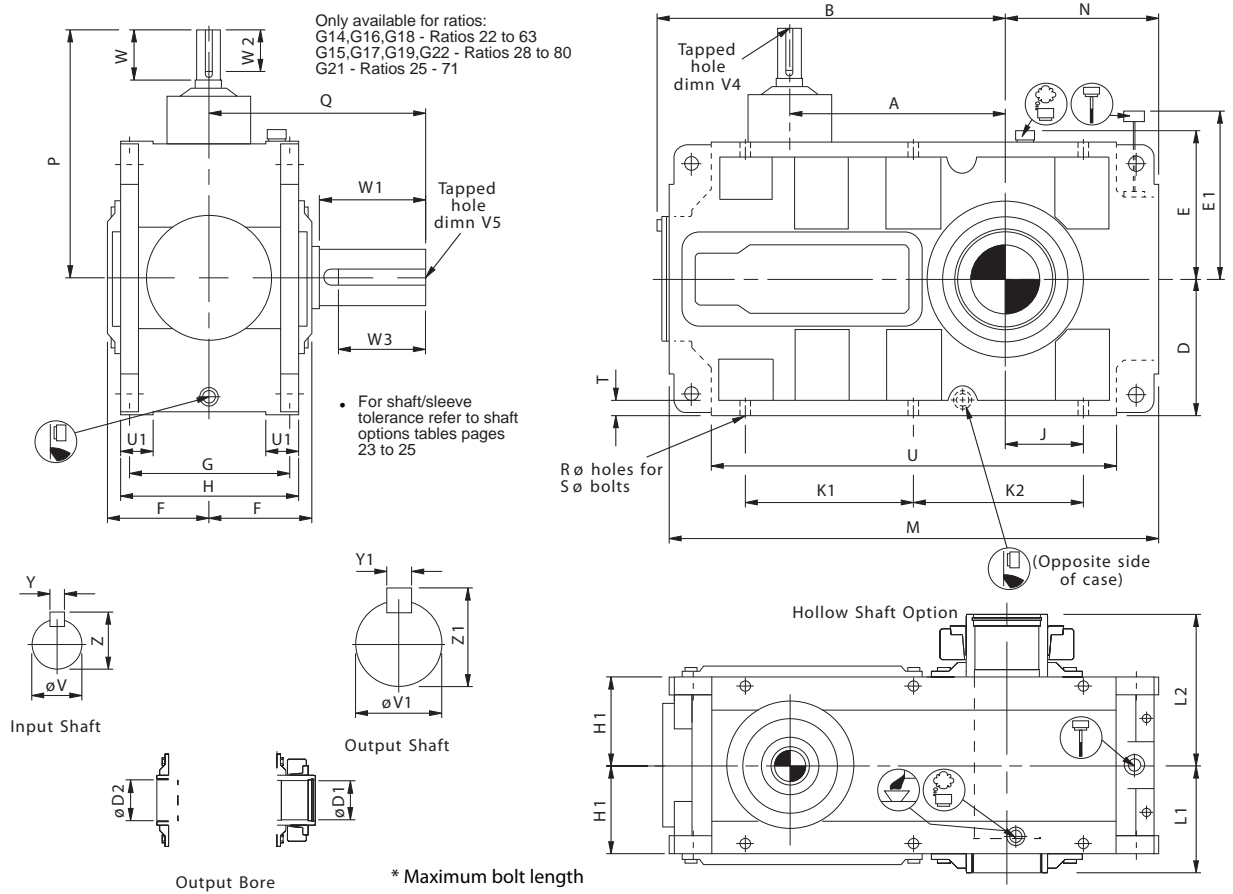

Unit Size	A	B	D	E	E1	F	G	H	H1	J	K1	K2	M	N	P	Q	R	S	T	U	U1
G14	12.80	21.81	9.06	9.84	14.57	6.97	10.43	11.81	5.91	6.69	11.22	0.00	32.28	11.61	15.55	14.17	0.73	6 x m16 x 60*	0.98	26.93	2.17
G15	14.37	23.39	9.06	9.84	14.57	6.97	10.43	11.81	5.91	5.12	11.22	0.00	32.28	10.04	15.55	14.57	0.73	6 x m16 x 60*	0.98	26.93	2.17
G16	16.93	28.66	11.81	13.19	20.28	8.86	12.99	14.96	7.48	8.86	15.16	0.00	41.73	14.57	20.08	18.11	1.10	6 X m24 X 80*	1.18	35.35	2.76
G17	19.09	30.83	11.81	13.19	20.28	8.86	12.99	14.96	7.48	6.69	15.16	0.00	41.73	12.40	20.08	18.90	1.10	6 x m24 x 80*	1.18	35.35	2.76
G18	22.44	37.52	15.16	16.54	27.95	11.42	17.32	19.69	9.84	6.02	20.47	13.78	48.82	13.31	25.59	23.62	1.30	6 x m30 x 100*	1.46	40.79	3.54
G19	25.00	40.08	15.16	16.54	27.95	11.42	17.32	19.69	9.84	8.66	19.69	0.00	54.09	16.02	25.59	25.59	1.30	6 x m30 x 100*	1.57	46.06	3.54
G21	30.12	48.82	18.31	19.96	29.53	13.39	20.87	23.62	11.81	8.86	27.36	18.90	65.16	18.31	34.06	27.56	1.54	6 x m36 x 100*	1.97	54.33	4.72
G22	31.69	50.39	18.31	19.96	29.53	13.39	20.87	23.62	11.81	9.65	29.33	19.29	67.52	19.09	34.06	28.74	1.54	6 x m36 x 100*	1.97	56.69	4.72

Unit Size	Input Shaft						Output Shaft						Output Bore			
	V	V4	W	W2	Y	Z	V1	V5	W1	W3	Y1	Z1	D1	D2	L1	L2
G14	1.500	5/8 UNF x 1.25	3.94	3.00	0.313	1.60	4.500	1 UNF x 2	7.09	6.50	1.00	4.94	3.74	3.94	7.09	10.04
G15	1.500	5/8 UNF x 1.25	3.94	3.00	0.313	1.60	5.000	1 UNF x 2	7.48	7.13	1.25	5.55	4.33	4.53	7.09	10.24
G16	1.875	5/8 UNF x 1.25	5.51	4.13	0.500	2.10	6.000	1.25 UNF x 2.5	9.06	8.75	1.50	6.66	4.92	5.12	9.06	12.80
G17	1.875	5/8 UNF x 1.25	5.51	4.13	0.500	2.10	6.750	1.25 UNF x 2.5	9.84	9.38	1.75	7.39	5.71	5.91	9.06	13.39
G18	3.000	3/4 UNF x 1.62	6.30	5.25	0.750	3.33	7.500	1.5 UNF x 3	11.81	11.38	1.75	8.15	6.30	6.69	11.81	16.14
G19	3.000	3/4 UNF x 1.62	6.30	5.25	0.750	3.33	8.250	1.5 UNF x 3	13.78	13.00	2.00	8.88	6.69	7.09	11.81	16.93
G21	4.000	1 UNF x 2	8.27	7.50	1.000	4.44	8.500	1.5 UNF x 3	13.78	13.00	2.00	9.13	8.27	8.66	13.78	19.69
G22	4.000	1 UNF x 2	8.27	7.50	1.000	4.44	9.250	1.5 UNF x 3	14.96	14.25	2.50	9.95	9.06	9.45	13.78	20.28

SERIES G

DIMENSIONS VERTICAL 'J' TYPE

RIGHT ANGLE SHAFTS TRIPLE REDUCTION

G **3** **0** **R**

Triple Reduction 'J' Type Right Angle Units Vertical

Only available for ratios:
G14, G16, G18 - Ratios 22 to 63
G15, G17, G19, G22 - Ratios 28 to 80
G21 - Ratios 25 - 71

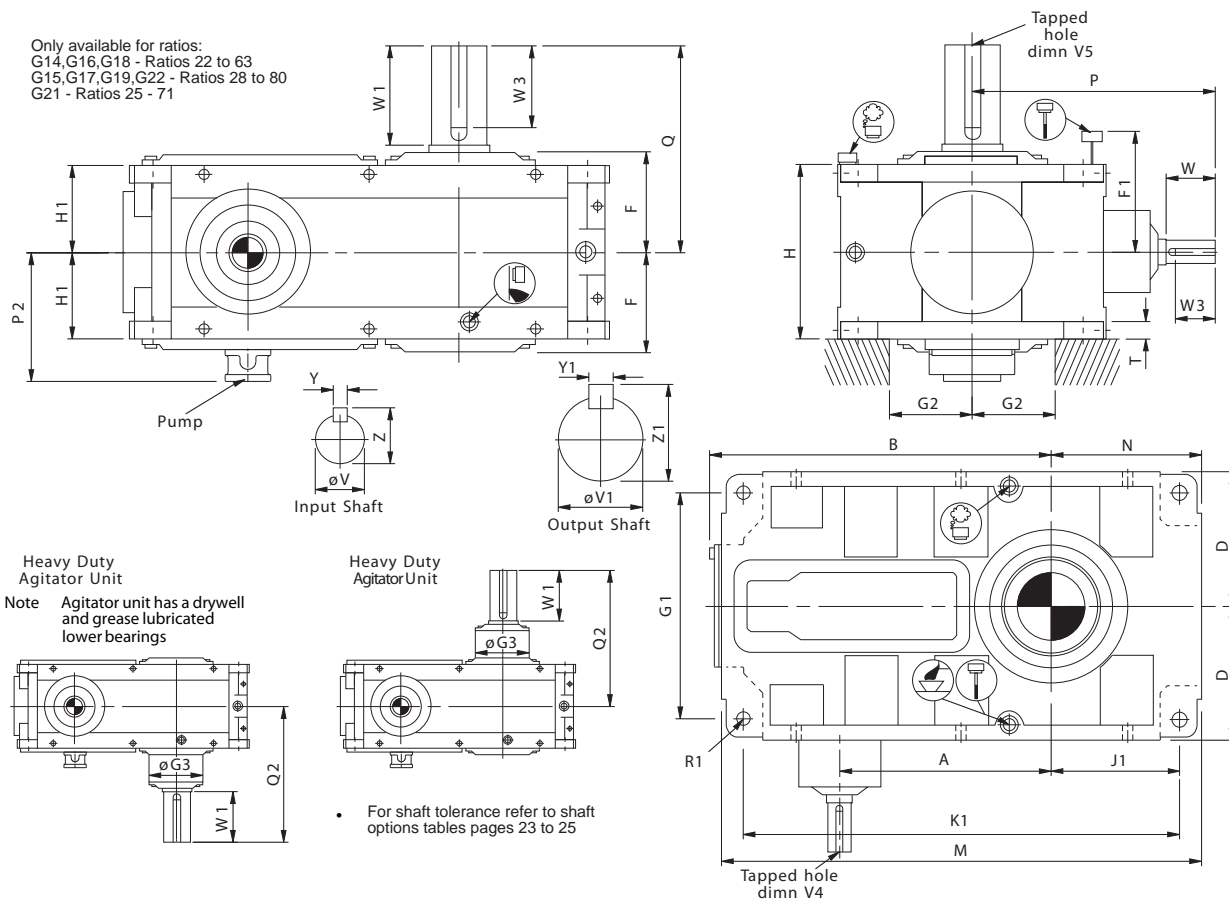

Heavy Duty Agitator Unit
Note Agitator unit has a drywell and grease lubricated lower bearings

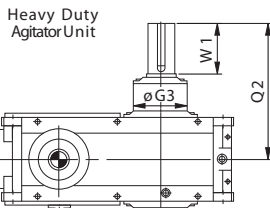

• For shaft tolerance refer to shaft options tables pages 23 to 25

Unit Size	A	B	D	F	F1	G1	G2 (min)	G3	H	H1	J1	K1	M	N	P	P2	Q	Q2	R1	T
G14	12.80	21.81	9.06	6.97	15.35	15.35	5.31	9.06	11.81	5.91	10.24	29.53	32.28	11.61	15.55	9.29	14.17	18.70	4 x Ø24	1.18
G15	14.37	23.39	9.06	6.97	15.35	15.35	5.31	10.24	11.81	5.91	8.66	29.53	32.28	10.04	15.55	9.29	14.57	19.49	4 x Ø24	1.18
G16	16.93	28.66	11.81	8.86	20.28	19.92	6.89	11.81	14.96	7.48	12.80	38.19	41.73	14.57	20.08	11.22	18.11	23.43	4 x Ø33	1.77
G17	19.09	30.83	11.81	8.86	20.28	19.92	6.89	13.39	14.96	7.48	10.63	38.19	41.73	12.40	20.08	11.22	18.90	24.21	4 x Ø33	1.77
G18	22.44	37.52	15.16	11.42	27.56	25.83	8.07	14.57	19.69	9.84	11.06	44.33	48.82	13.31	25.59	13.58	23.62	29.92	4 x Ø40	2.17
G19	25.00	40.08	15.16	11.42	27.56	25.83	8.07	15.75	19.69	9.84	13.78	49.61	54.09	16.02	25.59	13.58	25.59	32.09	4 x Ø40	2.17
G21	30.12	48.81	18.31	13.39	29.53	31.10	10.04	19.69	23.62	11.81	15.55	59.65	65.16	18.31	34.06	15.75	27.56	36.42	4 x Ø48	2.76
G22	31.69	50.39	18.31	13.39	29.53	31.10	10.43	*	23.62	11.81	16.34	62.01	67.52	19.09	34.06	15.75	28.74	*	4 x Ø48	2.76

Unit Size	Input Shaft						Output Shaft					
	V	V4	W	W2	Y	Z	V1	V5	W1	W3	Y1	Z1
G14	1.500	5/8 UNF x 1.25	3.94	3.00	0.313	1.60	4.500	1 UNF x 2	7.09	6.50	1.00	4.94
G15	1.500	5/8 UNF x 1.25	3.94	3.00	0.313	1.60	5.000	1 UNF x 2	7.48	7.13	1.25	5.55
G16	1.875	5/8 UNF x 1.25	5.51	4.13	0.500	2.10	6.000	1.25 UNF x 2.5	9.06	8.75	1.50	6.66
G17	1.875	5/8 UNF x 1.25	5.51	4.13	0.500	2.10	6.750	1.25 UNF x 2.5	9.84	9.38	1.75	7.39
G18	3.000	3/4 UNF x 1.62	6.30	5.25	0.750	3.33	7.500	1.5 UNF x 3	11.81	11.38	1.75	8.15
G19	3.000	3/4 UNF x 1.62	6.30	5.25	0.750	3.33	8.250	1.5 UNF x 3	13.78	13.00	2.00	8.88
G21	4.000	1 UNF x 2	8.27	7.50	1.000	4.44	8.500	1.5 UNF x 3	13.78	13.00	2.00	9.13
G22	4.000	1 UNF x 2	8.27	7.50	1.000	4.44	9.250	1.5 UNF x 3	14.26	14.25	2.50	9.95

SERIES G

FAN COOLING DIMENSIONS

RIGHT ANGLE SHAFTS

Right Angle Shaft Units with Mechanical Fans

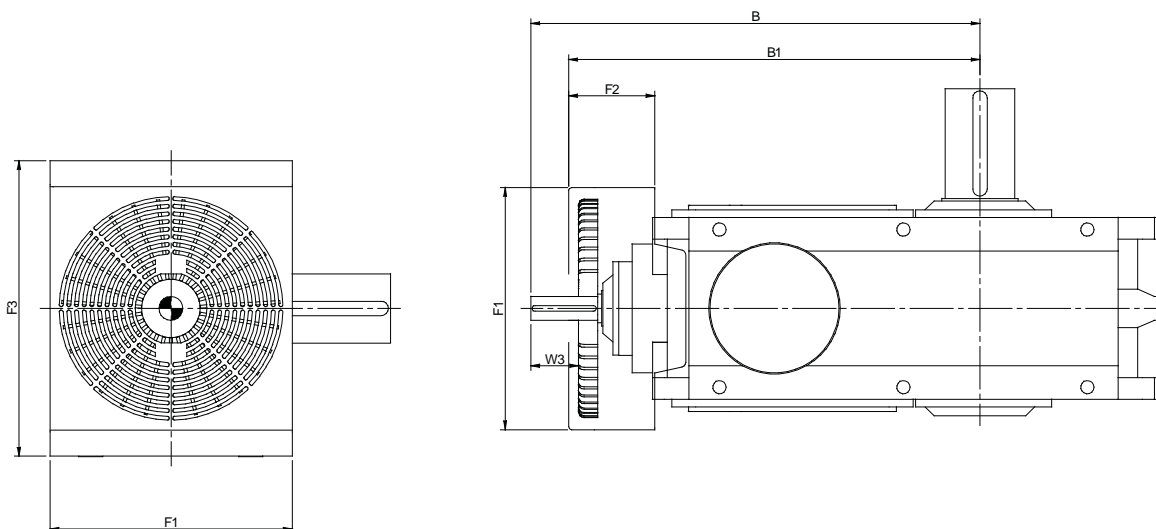

Triple Reduction Only

Unit Size	B	B1	F1	F2	F3	W3 (useable shaft extension)
G14	28.35	26.38	15.24	5.51	18.78	2.76
G15	29.92	27.95	15.24	5.51	18.78	2.76
G16	37.01	33.86	19.96	7.09	24.37	3.94
G17	39.17	36.02	19.96	7.09	24.37	3.94
G18	48.03	44.61	24.61	9.06	31.10	4.13
G19	50.59	47.17	24.61	9.06	31.10	4.13
G21	64.17	58.90	30.00	11.69	37.56	6.10
G22	65.75	60.47	30.00	11.69	37.56	6.10

SERIES G HOLLOW OUTPUT SHAFT WITH SHRINK DISC

The gear unit is fitted with a 'shrink disc' device located on the hollow output shaft to provide a positive outer locking connection between gear unit and driven shaft. The 'shrink disc' is a friction device, without keys, which exerts an external clamping force on the hollow output shaft, thus establishing a mechanical shrink fit between the gear unit hollow shaft and driven shaft. 'Shrink disc' capacities have ample margins in dealing with transmitted torques and external loading imposed on gear units.

WORKING PRINCIPLE

The 'shrink disc' consists of a locking collar, a tapered inner ring and locking screws. By tightening the locking screws, the locking collar and tapered inner ring are pulled together, exerting radial forces on the inner ring, thus creating a positive friction connection between hollow shaft and driven shaft.

As the tapered surfaces of locking collar and inner ring are lubricated with Molykote 321R or similar and the taper angle is not self locking, locking collar will not seize on the inner ring and can be released easily when removal is necessary.

When the shrink disc is clamped in position the high contact pressures between tapered surfaces and screw heads and their seatings ensure hermetic sealing and eliminate the possibility of fretting corrosion.

Unit Size	CUSTOMERS SHAFT								SHRINK DISC						
	ød1	ød2	ød3	ød4	l	l1	l2	K	Type	B	øD	øG	H	M	Torque Ta (lb-ft)
14	3.7402 3.7393	3.9370 3.9361	3.72	4.53	16.26	2.17	1.97	1" UNF x2"	HSD 120-81-95	0.87	4.72	7.76	2.09	M12	90
15	4.3307 4.3087	4.5276 4.5267	4.31	5.12	16.46	2.36	2.36	1" UNF x2"	HSD 140-81-110	0.87	5.51	9.06	2.28	M14	140
16	4.9213 4.9203	5.1181 5.1171	4.90	5.79	20.87	2.76	2.76	1" UNF x2"	HSD 160-81-125	1.10	6.30	11.42	2.68	M16	220
17	5.7087 5.7077	5.9055 5.9045	5.69	6.57	21.46	3.54	3.54	1 1/4" UNF x 2.36"	HSD 180-81-145	1.10	7.09	12.60	3.35	M16	220
18	6.2992 6.2983	6.6929 6.6914	6.28	7.28	26.97	3.54	3.54	1 1/4" UNF x 2.36"	HSD 200-81-160	1.18	7.87	13.39	3.35	M16	220
19	6.6923 6.6914	7.0861 7.0851	6.67	7.68	27.76	4.13	4.13	1 1/4" UNF x 2.36"	HSD 220-81-170	1.18	8.66	14.57	4.06	M20	420
21	8.2671 8.2659	8.6608 8.6596	8.25	8.86	32.28	5.12	4.13	1 1/4" UNF x 2.36"	HSD 260-81-210	1.18	10.24	16.93	4.69	M20	420
22	9.0545 9.0533	9.4482 9.4470	9.04	9.25	32.87	5.71	4.13	1 1/4" UNF x 2.36"	HSD 280-81-230	1.18	11.02	18.11	5.20	M20	420

Unit Size	HOLLOW SHAFT							END PLATE							
	ød1	ød2	ød3	L	L1	L2	L3	C	C1	ød5	ød6	øK1	M crs	P	Circlip
14	3.7415 3.7402	3.940 3.937	3.780	16.339	7.087	10.039	10.866	0.787	0.393 0.385	3.927 3.917	3.07	1.02	2.17	1/2" UNF	D1300-1000
15	4.3321 4.3307	4.531 4.528	4.370	16.535	7.087	10.236	10.866	0.787	0.393 0.385	4.518 4.508	3.54	1.02	2.56	1/2" UNF	D1300-1150
16	4.9228 4.9213	5.122 5.118	4.961	20.984	9.055	12.795	13.701	0.984	0.472 0.464	5.108 5.098	4.06	1.02	2.76	5/8" UNF	D1300-1300
17	5.7102 5.7087	5.909 5.906	5.787	21.575	9.055	13.386	13.701	0.984	0.472 0.464	5.896 5.886	4.72	1.30	3.35	5/8" UNF	D1300-1500
18	6.3008 6.2992	6.697 6.693	6.378	27.087	11.811	16.142	17.402	0.984	0.472 0.464	6.683 6.673	5.31	1.30	3.94	5/8" UNF	D1300-1700
19	6.6945 6.6929	7.091 7.087	6.772	27.874	11.811	16.929	17.402	0.984	0.472 0.464	7.274 7.264	5.91	1.30	4.33	5/8" UNF	D1300-1850
21	8.2695 8.2677	8.665 8.661	8.346	32.441	13.780	19.685	20.079	1.102	0.551 0.543	8.652 8.642	6.69	1.30	5.12	3/4" UNF	D1300-2200
22	9.0569 9.0551	9.452 9.448	9.134	33.031	13.780	20.276	21.063	1.102	0.551 0.543	9.439 9.433	7.48	1.30	5.91	3/4" UNF	D1300-2400

Customers Shaft

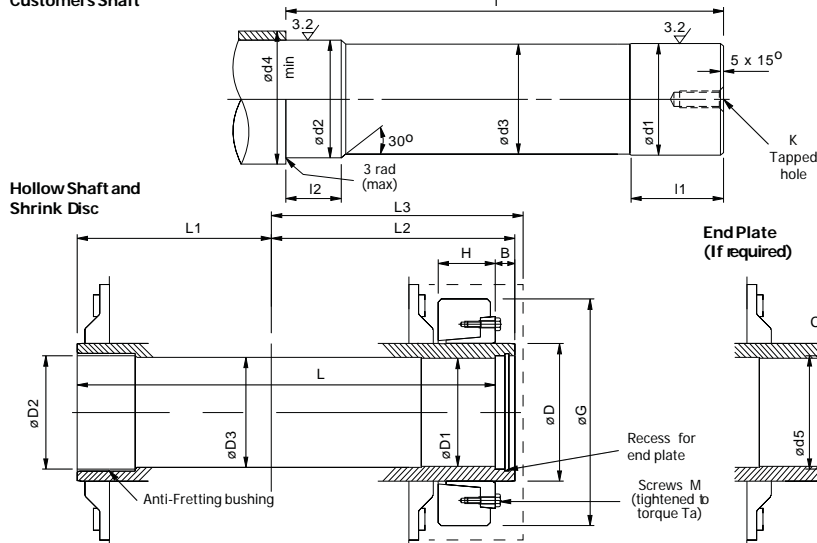

End Plate
(If required)

SERIES G

KEYED SLEEVES

Column 10 Entry

Inch W

Metric K

Consult Application Engineering for dimensions of metric sleeves

Customers Shaft

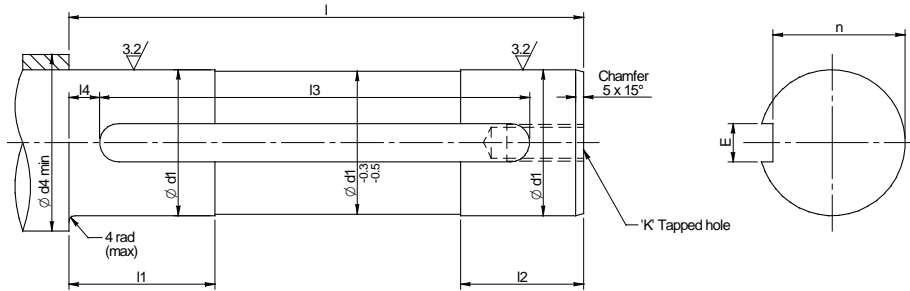

Hollow Shaft

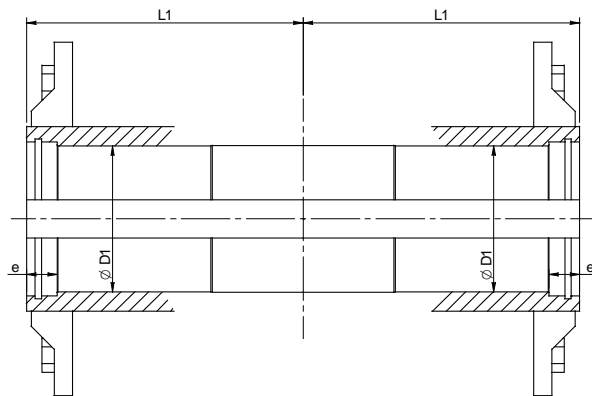

End Plate (if required)

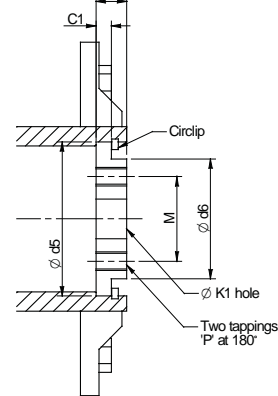

UNIT SIZE	CUSTOMERS SHAFT										
	$\varnothing d_1$	$\varnothing d_4$	l	l_1	l_2	l_3 (min)	l_4	m	n	k	Key Section (not supplied)
14	3.7500" 3.7491"	4.50"	13.19"	3.75"	3.12"	11.00"	0.75"	0.877" 0.875"	3.261" 3.246"	1" UNF 2.00" deep	0.875" square
15	4.3750" 4.3741"	5.12"	13.19"	4.12"	3.50"	11.00"	0.75"	1.002" 1.000"	3.817" 3.802"	1" UNF 2.00" deep	1.00" square
16	5.0000" 4.9990"	5.75"	16.91*	4.75"	3.88"	14.12"	1.00"	1.252" 1.250"	4.296" 4.281"	1" UNF 2.00" deep	1.25" square
17	5.7500" 5.7490"	6.56"	16.91"	5.12"	4.38"	14.12"	1.00"	1.502" 1.500"	4.900" 4.885"	1.1/4" UNF 2.50" deep	1.50" square
18	6.2500" 6.2490"	7.56"	22.44"	5.75"	5.00"	20.50"	1.00"	1.502" 1.500"	5.409" 5.394"	1.1/4" UNF 2.50" deep	1.50" square
19	6.9994" 6.9984"	8.12"	22.44"	6.12"	5.38"	20.50"	1.00"	1.752" 1.750"	6.139" 6.124"	1.1/4" UNF 2.50" deep	1.75" x 1.50"
21	8.2494" 8.2482"	8.88"	26.38"	6.50"	5.75"	24"	1.12"	2.002" 2.000"	7.377" 7.362"	1.1/4" UNF 2.50" deep	2.00" x 1.50"
22	8.9994" 8.9982"	9.84"	26.38"	6.88"	6.12"	24"	1.12"	2.002" 2.000"	8.137" 8.122"	1.1/4" UNF 2.50" deep	2.00" x 1.50"

UNIT SIZE	HOLLOW SHAFT			END PLATE							
	$\varnothing D_1$	e	L_1	C	C_1	$\varnothing d_5$	$\varnothing d_6$	$\varnothing K_1$	M crs	P	Circlip
14	3.7514" 3.7500"	0.750"	7.09"	0.75"	0.375" 0.370"	4.000" 3.990"	3.0"	1.06"	2.12"	1/2" UNF	N1300-0400
15	4.3764" 4.3750"	0.750"	7.09"	0.75"	0.375" 0.370"	4.625" 4.615"	3.5"	1.06"	2.50"	1/2" UNF	N1300-0462
16	5.0016" 5.0000"	0.875"	9.06"	1.00"	0.500" 0.495"	5.250" 5.240"	4.0"	1.06"	2.75"	5/8" UNF	N1300-0500
17	5.7516" 5.7500"	0.875"	9.06"	1.00"	0.500" 0.495"	6.000" 5.990"	4.75"	1.38"	3.38"	5/8" UNF	N1300-0575
18	6.2516" 6.2500"	0.875"	11.81"	1.00"	0.500" 0.495"	6.750" 6.740"	5.31"	1.38"	4.00"	5/8" UNF	N1300-0625
19	7.0016" 7.0000"	0.875"	11.81"	1.00"	0.500" 0.495"	7.250" 7.240"	5.88"	1.38"	4.38"	5/8" UNF	N1300-0700
21	8.2518" 8.2500"	1.000"	13.78"	1.12"	0.563" 0.558"	8.750" 8.740"	6.75"	1.38"	5.12"	3/4" UNF	N1300-0825
22	9.0018" 9.0000"	1.000"	13.78"	1.12"	0.563" 0.558"	9.500" 9.490"	7.50"	1.38"	5.88"	3/4" UNF	N1300-0900

COOLING COIL CONNECTIONS

Cooling coils can be fitted to all unit types and handings.

Cooling coil connections for water inlet and outlet pipes are $\varnothing 0.47''$ ($\varnothing 12\text{ mm}$) on all sizes.

The protruding cooling coil pipe can be connected to customers pipe work via a suitable straight coupling.

Water supply: Cooling coils are suitable for fresh, brackish or sea water with flow in either direction. Connections are therefore interchangeable.

For best performance, the water supply should be at 50°F / 54°F temperature and at a flow rate of 1.3 gallons per minute.

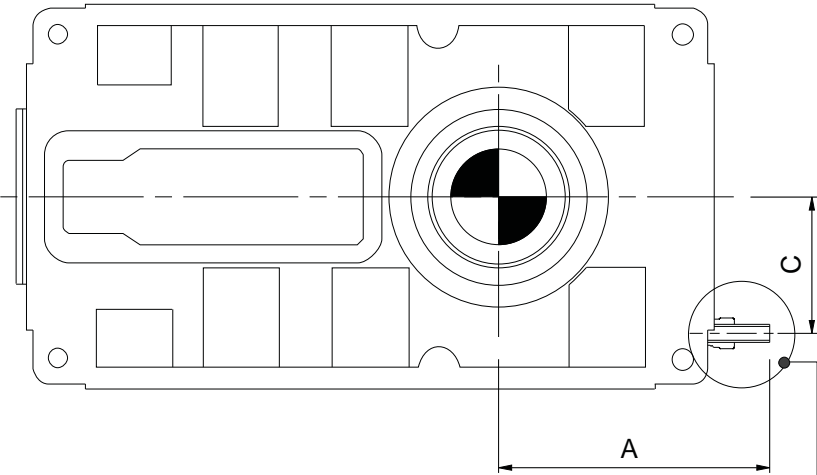
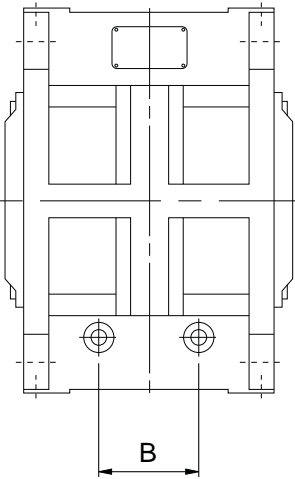

SIZE OF UNIT	A	B	C
14	12.20	4.72	6.42
15	10.63	4.72	6.42
16	14.57	5.91	8.66
17	12.40	5.91	8.66
18	12.40	7.87	11.22
19	15.16	7.87	11.22
21	15.75	7.87	13.98
22	16.54	7.87	13.98

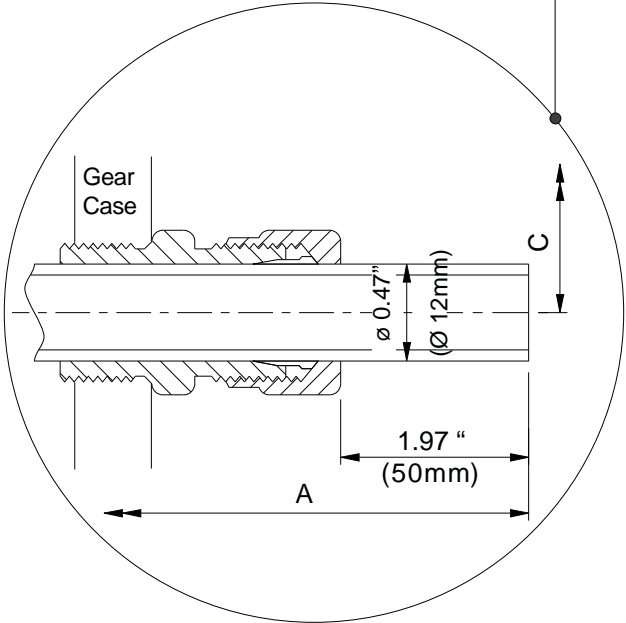

BACKSTOPS

Externally mounted Backstops can be fitted to all Series G gear units, when required to operate in non-reversing drives. They are located on the helical pinion shaft and have adequate capacities to deal with full rated torques. All backstops are centrifugal lift off type. Changing the direction of locking rotation is a simple operation.

Parallel Shaft Units

Column 16 entry, shaft rotation shown

3 Stage

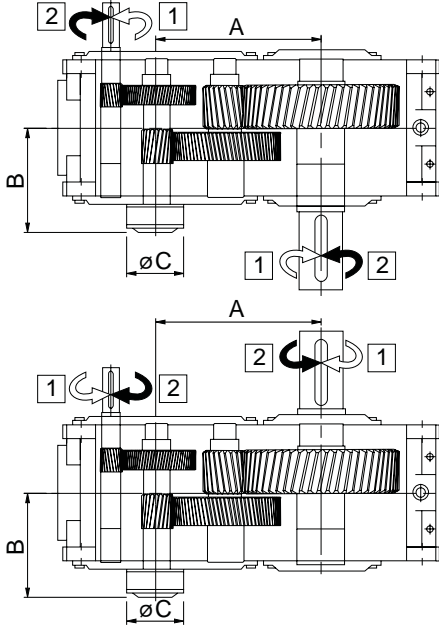

4 Stage

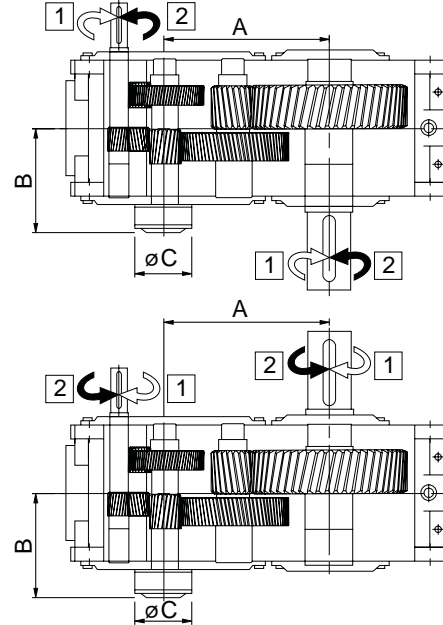

Right Angle Shaft Units

Column 16 entry, shaft rotation shown

For right angle units, if backstop position is required at opposite side of unit to outputshaft, column 16 entry must be 3 or 4 (see page 11)

3 Stage

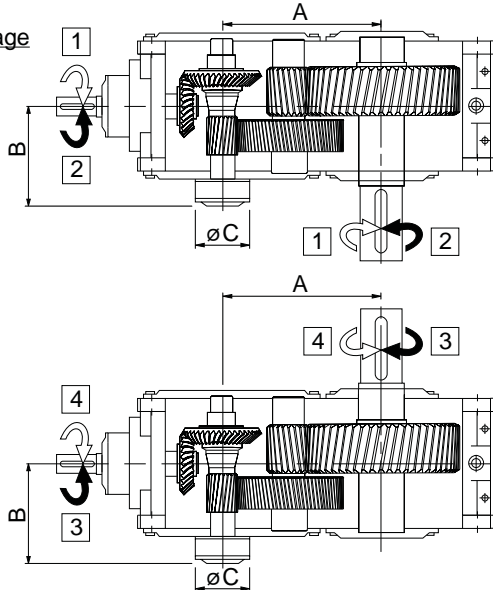

4 Stage

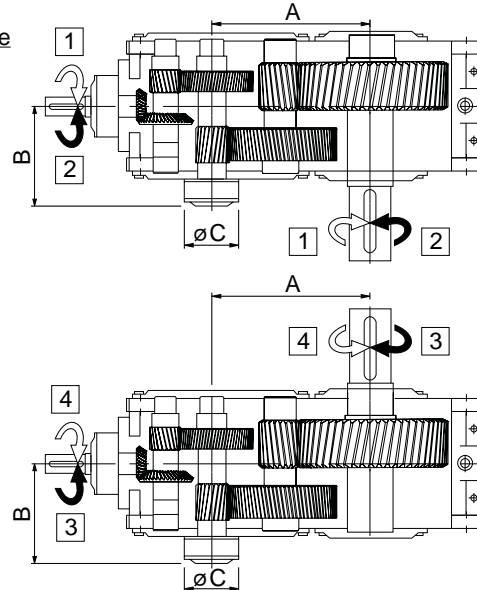

Unit Size	A	B	øC	Backstop
G14	12.80	10.83	6.89	85-40
G15	14.37			
G16	16.93	13.39	8.27	120-50
G17	19.09			
G18	22.44	17.05	11.42	170-63
G19	25.00			
G21	30.12	19.69	12.20	200-63
G22	31.69			

Note: Torque limiting backstops with controllable tension release can be fitted to all Series G units. (For details consult our Application Engineers).

TORQUE ARM

Torque arms are available for all shaft mounted units with parallel or right angle shafts. They are supplied as optional extras and are secured to gear cases as shown below.

Torque arms must be secured to the chassis structure in a flexible mounting as indicated.

Shaft mounted units are designed to operate in the horizontal position. Reference must be made to our Application Engineers, with details, where units are required to operate in an inclined position.

SHAFT MOUNTED UNITS FOR HIGH INERTIA DRIVE

When used on Traverse drives with high inertia driven loads, e.g. crane drives (slewing, long travel and cross travel) bogie drives and selected high inertia load roller table drives, it is recommended that shaft mounted units should be fitted with shock absorbing Torque Arms. Consult our Application Engineers with specific application details.

It is recommended that the torque arm is fitted on the side of the unit adjacent to the driven machine.

The torque arm must be flexibly mounted to the chassis structure

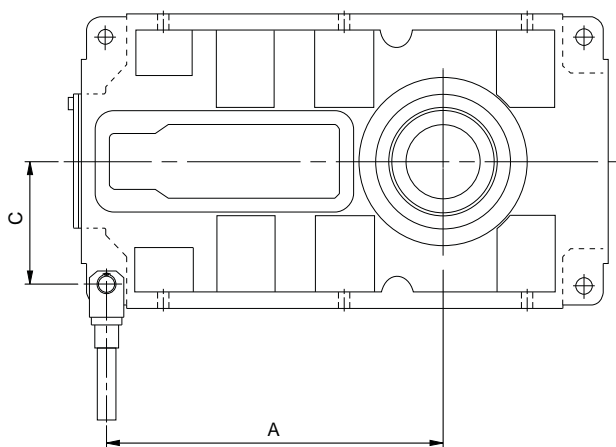
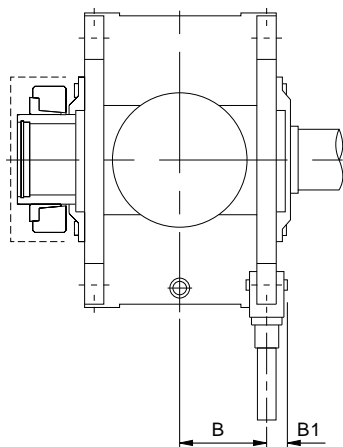
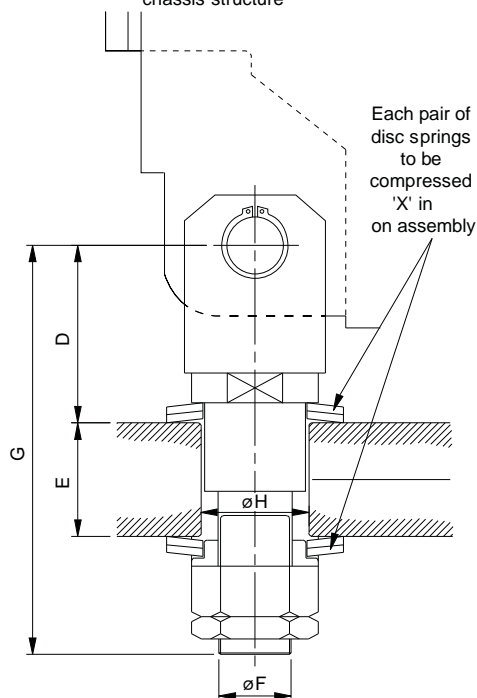

SIZE OF UNIT	A	B	B1	C	D	E		F	G	Disc Spring Ref	X	H
						MIN	MAX					
14	19.29	5.31	2.17	7.68	3.74	1.57	2.36	M30	8.15	80 x 41 x 4	0.04	1.61
15	20.87											
16	25.39	6.57	2.56	9.96	4.92	1.97	2.95	M36	10.31	100 x 51 x 6	0.04	2.05
17	27.56											
18	33.27	8.74	3.15	12.91	5.91	2.76	4.13	M48	13.23	125 x 71 x 6	0.07	2.83
19	35.83											
21 & 22	Contact our Application Engineers											

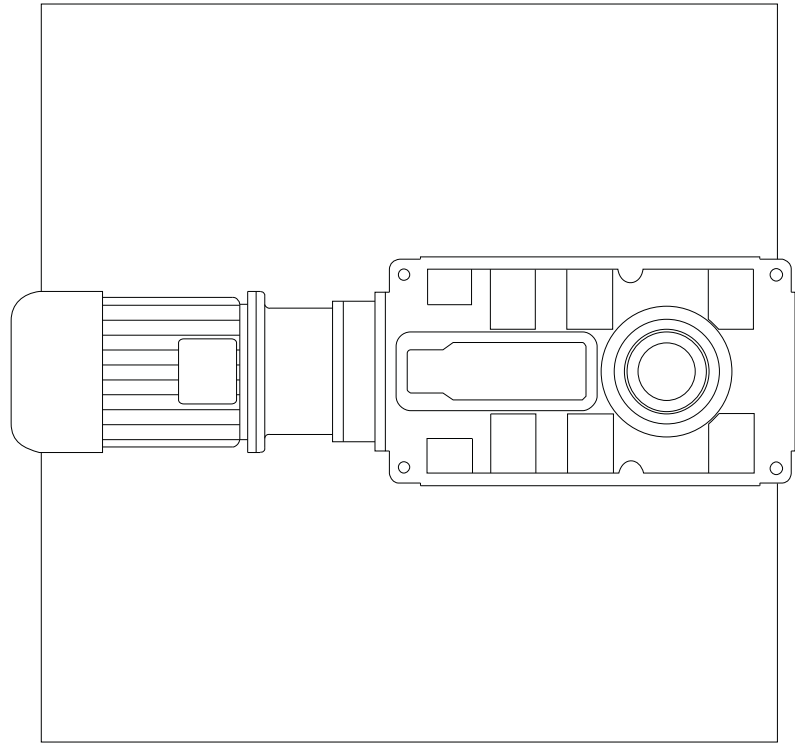

**MOTORIZED
SERIES G**

MOTORIZED DIMENSIONS

Parallel Shaft Units

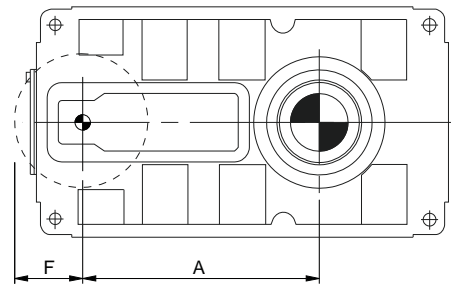
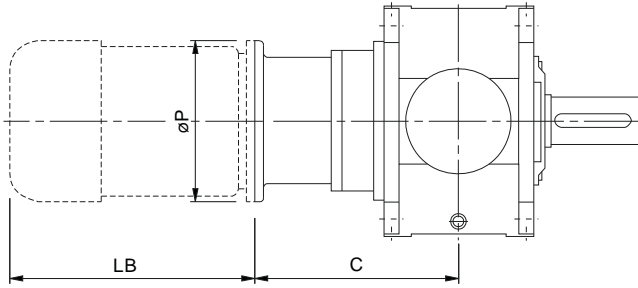

Double Reduction

NEMA Motors						
Unit Size	Motor Size	Column 13 Entry	C	F	LB (max)	ØP
G1420	324TC/326TC	R	17.52	9.02	25.87	13.37
	364TC/365TC	S	18.15	9.02	30.91	13.37
	404TC/405TC	T	19.52	9.02	33.03	13.87
G1520	324TC/326TC	R	17.52	9.02	25.87	13.37
	364TC/365TC	S	18.15	9.02	30.91	13.37
	404TC/405TC	T	19.52	9.02	33.03	13.87
G1620	364TC/365TC	S	20.31	15.08	30.91	13.37
	404TC/405TC	T	21.69	15.08	33.03	13.87
G1720	364TC/365TC	S	20.31	15.08	30.91	13.37
	404TC/405TC	T	21.69	15.08	33.03	13.87

IEC Motors							
Unit Size	Motor Size	Column 13 Entry	A	C	F	LB (max)	ØP
G1420	200	D	12.80	16.85	9.02	25.63	15.75
	225	E	12.80	18.03	9.02	30.94	17.72
	250	F	12.80	18.03	10.83	33.03	21.65
	280	G	12.80	18.03	10.83	37.44	21.65
G1520	200	D	14.37	16.85	9.02	25.63	15.75
	225	E	14.37	18.03	9.02	30.94	17.72
	250	F	14.37	18.03	10.83	33.03	21.65
	280	G	14.37	18.03	10.83	37.44	21.65
G1620	250	F	16.93	20.20	11.73	33.03	21.65
	280	G	16.93	20.20	11.73	37.44	21.65
G1720	250	F	19.09	20.20	11.73	33.03	21.65
	280	G	19.09	20.20	11.73	37.44	21.65

Triple and Quadruple Reduction

NEMA Motors						
Unit Size	Motor Size	Column 13 Entry	C	F	LB (max)	ØP
G1430 / G1440	254TC/256TC	P	14.69	6.69	21.50	10.00
	284TC/286TC	Q	15.32	6.69	23.82	11.25
	324TC/326TC	R	15.94	6.69	25.87	13.37
	364TC/365TC	S	16.57	6.69	30.91	13.37
	404TC/405TC	T	17.94	6.97	33.03	13.87
G1530 / G1540	254TC/256TC	P	14.69	6.69	21.50	10.00
	284TC/286TC	Q	15.32	6.69	23.82	11.25
	324TC/326TC	R	15.94	6.69	25.87	13.37
	364TC/365TC	S	16.57	6.69	30.91	13.37
	404TC/405TC	T	17.94	6.97	33.03	13.87
G1630 / G1640	254TC/256TC	P	17.25	6.69	21.50	10.00
	284TC/286TC	Q	17.88	6.69	23.82	11.25
	324TC/326TC	R	18.50	6.69	25.87	13.37
	364TC/365TC	S	19.13	6.69	30.91	13.37
	404TC/405TC	T	20.50	6.97	33.03	13.87
G1730 / G1740	254TC/256TC	P	17.25	6.69	21.50	10.00
	284TC/286TC	Q	17.88	6.69	23.82	11.25
	324TC/326TC	R	18.50	6.69	25.87	13.37
	364TC/365TC	S	19.13	6.69	30.91	13.37
	404TC/405TC	T	20.50	6.97	33.03	13.87
G1830 / G1840	254TC/256TC	P	21.19	7.80	21.50	10.00
	284TC/286TC	Q	21.81	7.80	23.82	11.25
	324TC/326TC	R	22.44	7.80	25.87	13.37
	364TC/365TC	S	23.07	7.80	30.91	13.37
	404TC/405TC	T	24.44	7.80	33.03	13.87
G1930 / G1940	254TC/256TC	P	21.19	7.80	21.50	10.00
	284TC/286TC	Q	21.81	7.80	23.82	11.25
	324TC/326TC	R	22.44	7.80	25.87	13.37
	364TC/365TC	S	23.07	7.80	30.91	13.37
	404TC/405TC	T	24.44	7.80	33.03	13.87

IEC Motors							
Unit Size	Motor Size	Column 13 Entry	A	C	F	LB (max)	ØP
G1430 / G1440	132	A	17.13	14.09	6.69	16.54	11.81
	160	B	17.13	15.28	6.89	21.26	13.78
	180	C	17.13	15.28	6.89	23.54	13.78
	200	D	17.13	15.28	7.87	25.63	15.75
	225	E	17.13	16.46	8.86	30.94	17.72
	250	F	17.13	16.46	10.83	33.03	21.65
G1530 / G1540	132	A	18.70	14.09	6.69	16.54	11.81
	160	B	18.70	15.28	6.89	21.26	13.78
	180	C	18.70	15.28	6.89	23.54	13.78
	200	D	18.70	15.28	7.87	25.63	15.75
	225	E	18.70	16.46	8.86	30.94	17.72
	250	F	18.70	16.46	10.83	33.03	21.65
G1630 / G1640	132	A	22.44	16.65	6.69	16.54	11.81
	160	B	22.44	17.83	6.89	21.26	13.78
	180	C	22.44	17.83	6.89	23.54	13.78
	200	D	22.44	17.83	7.87	25.63	15.75
	225	E	22.44	19.02	8.86	30.94	17.72
	250	F	22.44	19.02	10.83	33.03	21.65
G1730 / G1740	132	A	24.61	16.65	6.69	16.54	11.81
	160	B	24.61	17.83	6.89	21.26	13.78
	180	C	24.61	17.83	6.89	23.54	13.78
	200	D	24.61	17.83	7.87	25.63	15.75
	225	E	24.61	19.02	8.86	30.94	17.72
	250	F	24.61	19.02	10.83	33.03	21.65
G1830 / G1840	180	C	29.72	21.77	7.80	23.54	13.78
	200	D	29.72	21.77	7.87	25.63	15.75
	225	E	29.72	22.95	8.86	30.94	17.72
	250	F	29.72	22.95	10.83	33.03	21.65
	280	G	29.72	22.95	10.83	37.44	21.65
	G1930 / G1940	180	C	32.28	21.77	7.80	23.54
200		D	32.28	21.77	7.87	25.63	15.75
225		E	32.28	22.95	8.86	30.94	17.72
250		F	32.28	22.95	10.83	33.03	21.65
280		G	32.28	22.95	10.83	37.44	21.65

MOTORIZED DIMENSIONS

Right Angle Shaft Units

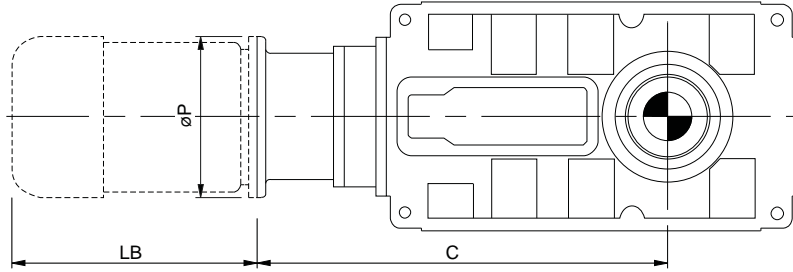

Triple Reduction

NEMA Motors					
Unit Size	Motor Size	Column 13 Entry	C	LB (max)	ØP
G1430	254TC/256TC	P	32.22	21.50	10.00
	284TC/286TC	Q	32.84	23.82	11.25
	324TC/326TC	R	33.46	25.87	13.37
	364TC/365TC	S	34.09	30.91	13.37
	404TC/405TC	T	35.46	33.03	13.87
G1530	254TC/256TC	P	33.79	21.50	10.00
	284TC/286TC	Q	34.41	23.82	11.25
	324TC/326TC	R	35.04	25.87	13.37
	364TC/365TC	S	35.67	30.91	13.37
	404TC/405TC	T	37.04	33.03	13.87
G1630	324TC/326TC	R	42.13	25.87	13.37
	364TC/365TC	S	42.75	30.91	13.37
	404TC/405TC	T	44.13	33.03	13.87
G1730	324TC/326TC	R	44.33	25.87	13.37
	364TC/365TC	S	44.92	30.91	13.37
	404TC/405TC	T	46.29	33.03	13.87
G1830	364TC/365TC	S	53.78	30.91	13.37
	404TC/405TC	T	55.15	33.03	13.87
G1930	364TC/365TC	S	56.33	30.91	13.37
	404TC/405TC	T	57.71	33.03	13.87

IEC Motors					
Unit Size	Motor Size	Column 13 Entry	C	LB (max)	ØP
G1430	132	A	31.61	16.54	11.81
	160	B	32.80	21.26	13.78
	180	C	32.80	23.54	13.78
	200	D	32.80	25.63	15.75
	225	E	33.98	30.94	17.72
	250	F	33.98	33.03	21.65
	280	G	33.98	37.44	21.65
G1530	132	A	33.19	16.54	11.81
	160	B	34.37	21.26	13.78
	180	C	34.37	23.54	13.78
	200	D	34.37	25.63	15.75
	225	E	35.55	30.94	17.72
	250	F	35.55	33.03	21.65
	280	G	35.55	37.44	21.65
G1630	200	D	41.46	25.63	15.75
	225	E	42.64	30.94	17.72
	250	F	42.64	33.03	21.65
	280	G	42.64	37.44	21.65
G1730	200	D	43.62	25.63	15.75
	225	E	44.80	30.94	17.72
	250	F	44.80	33.03	21.65
	280	G	44.80	37.44	21.65
G1830	225	E	53.66	30.94	17.72
	250	F	53.66	33.03	21.65
	280	G	53.66	37.44	21.65
G1930	225	E	56.22	30.94	17.72
	250	F	56.22	33.03	21.65
	280	G	56.22	37.44	21.65

Quadruple Reduction

NEMA Motors					
Unit Size	Motor Size	Column 13 Entry	C	LB (max)	ØP
G1640	254TC/256TC	P	41.86	21.50	10.00
	284TC/286TC	Q	42.48	23.82	11.25
	324TC/326TC	R	43.11	25.87	13.37
	364TC/365TC	S	43.74	30.91	13.37
	404TC/405TC	T	45.11	33.03	13.87
G1740	254TC/256TC	P	44.03	21.50	10.00
	284TC/286TC	Q	44.65	23.82	11.25
	324TC/326TC	R	45.28	25.87	13.37
	364TC/365TC	S	45.90	30.91	13.37
	404TC/405TC	T	47.28	33.03	13.87
G1840	254TC/256TC	P	53.67	21.50	10.00
	284TC/286TC	Q	54.30	23.82	11.25
	324TC/326TC	R	54.96	25.87	13.37
	364TC/365TC	S	55.55	30.91	13.37
	404TC/405TC	T	56.92	33.03	13.87
G1940	254TC/256TC	P	56.25	21.50	10.00
	284TC/286TC	Q	56.85	23.82	11.25
	324TC/326TC	R	57.52	25.87	13.37
	364TC/365TC	S	58.11	30.91	13.37
	404TC/405TC	T	59.48	33.03	13.87

IEC Motors					
Unit Size	Motor Size	Column 13 Entry	C	LB (max)	ØP
G1640	132	A	41.26	16.54	11.81
	160	B	42.44	21.26	13.78
	180	C	42.44	23.54	13.78
	200	D	42.44	25.63	15.75
	225	E	43.62	30.94	17.72
	250	F	43.62	33.03	21.65
G1740	132	A	43.82	16.54	11.81
	160	B	44.61	21.26	13.78
	180	C	44.61	23.54	13.78
	200	D	44.61	25.63	15.75
	225	E	45.79	30.94	17.72
	250	F	45.79	33.03	21.65
G1840	160	B	54.25	21.26	13.78
	180	C	54.25	23.54	13.78
	200	D	54.25	25.63	15.75
	225	E	55.43	30.94	17.72
	250	F	55.43	33.03	21.65
	280	G	55.43	37.44	21.65
G1940	160	B	56.81	21.26	13.78
	180	C	56.81	23.54	13.78
	200	D	56.81	25.63	15.75
	225	E	57.99	30.94	17.72
	250	F	57.99	33.03	21.65
	280	G	57.99	37.44	21.65

SERIES G

SHIPPING SPECIFICATIONS

UNIT MASS (lb's)

Gear Unit	No of Reductions	Output Shaft	Unit Size							
			14	15	16	17	18	19	21	22
Parallel Shaft	2 Stage	Standard	794	915	1743	1996	3375	4136	6949	8030
		Shaft Mount	750	849	1666	1886	3166	3872	6508	7430
		Agitator	882	1004	1853	2162	3596	4401	7390	-
	3 Stage	Standard	827	949	1776	2030	3419	4180	7059	8140
		Shaft Mount	783	882	1699	1919	3210	3916	6618	7540
		Agitator	915	1037	1886	2195	3640	4445	7500	-
	4 Stage	Standard	849	971	1809	2063	3485	4247	7170	8250
		Shaft Mount	805	893	1732	1952	3276	3982	6728	7650
		Agitator	938	1059	1919	2228	3706	4511	7611	-
Right Angle Shaft	3 Stage	Standard	871	993	1853	2074	3618	4379	7390	8471
		Shaft Mount	827	927	1775	1963	3408	4114	6949	7870
		Agitator	960	1081	1963	2239	3838	4644	7831	-
	4 Stage	Standard	-	-	1853	2074	3574	4335	7280	8361
		Shaft Mount	-	-	1775	1555	3364	4070	6839	7760
		Agitator	-	-	1963	1963	3794	4600	7721	-

Mass excludes: lubricant, cooling fans or coil.

UNIT VOLUME (Feet ³)

Gear Unit	No of Reductions	Output Shaft	Unit Size							
			14	15	16	17	18	19	21	22
Parallel Shaft	2 Stage	Standard	9.7	9.9	20.4	20.9	39.6	45.8	73.5	78.0
		Shaft Mount	7.1	7.1	14.8	14.8	28.6	31.6	62.2	65.0
		Agitator	10.9	11.2	22.5	22.9	43.5	50.2	83.0	-
	3 Stage	Standard	9.1	9.3	19.7	20.2	38.2	44.1	72.7	78
		Shaft Mount	6.5	6.5	14.0	14.0	27.2	30.0	60.7	63.60
		Agitator	10.3	10.6	21.8	22.2	42.1	48.6	81.9	-
	4 Stage	Standard	9.1	9.3	19.7	20.2	38.2	44.1	72.7	76.60
		Shaft Mount	6.5	6.5	14.0	14.0	27.2	30.0	60.7	63.6
		Agitator	10.3	10.6	21.8	22.2	42.1	48.6	81.9	-
Right Angle Shaft	3 Stage	Standard	9.3	9.4	20.1	20.7	39.4	45.2	74.9	77.0
		Shaft Mount	7.5	7.6	16.3	16.7	31.4	35.1	61.1	64.0
		Agitator	10.7	11.1	22.8	23.3	44.5	50.9	51.9	-
	4 Stage	Standard	-	-	20.5	21.1	40.5	46.4	75.9	78.0
		Shaft Mount	-	-	16.6	17.1	32.3	36.1	62.2	65.0
		Agitator	-	-	23.2	23.8	45.8	52.2	88.3	-

IMPORTANT

Product Safety Information

General - The following information is important in ensuring safety. It **must** be brought to the attention of personnel involved in the selection of the equipment, those responsible for the design of the machinery in which it is to be incorporated and those involved in its installation, use and maintenance.

The equipment will operate safely provided it is selected, installed, used and maintained properly. As with any power transmission equipment **proper precautions must** be taken as indicated in the following paragraphs, to ensure safety.

Potential Hazards - these are **not** necessarily listed in any order of severity as the degree of danger varies in individual circumstances. It is important therefore that the list is studied in its entirety:-

- 1) Fire/Explosion
 - (a) Oil mists and vapour are generated within gear units. It is therefore dangerous to use naked lights in the proximity of gearbox openings, due to the risk of fire or explosion.
 - (b) In the event of fire or serious overheating (over 300 °C), certain materials (rubber, plastics, etc.) may decompose and produce fumes. Care should be taken to avoid exposure to the fumes, and the remains of burned or overheated plastic/rubber materials should be handled with rubber gloves.
- 2) Guards - Rotating shafts and couplings must be guarded to eliminate the possibility of physical contact or entanglement of clothing. It should be of rigid construction and firmly secured.
- 3) Noise - High speed gearboxes and gearbox driven machinery may produce noise levels which are damaging to the hearing with prolonged exposure. Ear defenders should be provided for personnel in these circumstances. Reference should be made to the Department of Employment Code of Practice for reducing exposure of employed persons to noise.
- 4) Lifting - Where provided (on larger units) only the lifting points or eyebolts must be used for lifting operations (see maintenance manual or general arrangement drawing for lifting point positions). Failure to use the lifting points provided may result in personal injury and/or damage to the product or surrounding equipment. Keep clear of raised equipment.
- 5) Lubricants and Lubrication
 - (a) Prolonged contact with lubricants can be detrimental to the skin. The manufacturer's instruction must be followed when handling lubricants.
 - (b) The lubrication status of the equipment must be checked before commissioning. Read and carry out all instructions on the lubricant plate and in the installation and maintenance literature. Heed all warning tags. Failure to do so could result in mechanical damage and in extreme cases risk of injury to personnel.
- 6) Electrical Equipment - Observe hazard warnings on electrical equipment and isolate power before working on the gearbox or associated equipment, in order to prevent the machinery being started.
- 7) Installation, Maintenance and Storage
 - (a) In the event that equipment is to be held in storage, for a period exceeding 6 months, prior to installation or commissioning, application engineering must be consulted regarding special preservation requirements. Unless otherwise agreed, equipment must be stored in a building protected from extremes of temperature and humidity to prevent deterioration.

The rotating components (gears and shafts) must be turned a few revolutions once a month (to prevent bearings brinelling).
 - (b) External gearbox components may be supplied with preservative materials applied, in the form of a "waxed" tape overwrap or wax film preservative. Gloves should be worn when removing these materials. The former can be removed manually, the latter using white spirit as a solvent.

Preservatives applied to the internal parts of the gear units do not require removal prior to operation.
 - (c) Installation must be performed in accordance with the manufacturer's instructions and be undertaken by suitably qualified personnel.
 - (d) Before working on a gearbox or associated equipment, ensure that the load has been removed from the system to eliminate the possibility of any movement of the machinery and isolate power supply. Where necessary, provide mechanical means to ensure the machinery cannot move or rotate. Ensure removal of such devices after work is complete.
 - (e) Ensure the proper maintenance of gearboxes in operation. Use only the correct tools and approved spare parts for repair and maintenance. Consult the Maintenance Manual before dismantling or performing maintenance work.
- 8) Hot Surfaces and Lubricants
 - (a) During operation, gear units may become sufficiently hot to cause skin burns. Care must be taken to avoid accidental contact.
 - (b) After extended running the lubricant in gear units and lubrication systems may reach temperatures sufficient to cause burns. Allow equipment to cool before servicing or performing adjustments.
- 9) Selection and Design
 - (a) Where gear units provide a backstop facility, ensure that back-up systems are provided if failure of the backstop device would endanger personnel or result in damage.
 - (b) The driving and driven equipment must be correctly selected to ensure that the complete machinery installation will perform satisfactorily, avoiding system critical speeds, system torsional vibration, etc.
 - (c) The equipment must not be operated in an environment or at speeds, powers, torques or with external loads beyond those for which it was designed.
 - (d) As improvements in design are being made continually the contents of this catalogue are not to be regarded as binding in detail, and drawings and capacities are subject to alterations without notice.

The above guidance is based on the current state of knowledge and our best assessment of the potential hazards in the operation of the gear units.

Any further information or clarification required may be obtained by contacting an Application Engineer.

AUSTRALIA

David Brown Gear Industries Ltd
13-19 Franklin Avenue
Bulli, NSW 2516
Australia

Tel: +61 2 4283 0300
Fax: +61 2 4283 0333

CHINA

David Brown Gear Systems Trading (Shanghai) Co. Ltd
No. 218 Xi Zhang South Road, Silver Tower, Suite 1204B Shangai 200021 P.R. China

Tel: +86 21 53966 555
Fax: +86 21 53966 913

DENMARK

Benzler Transmission A/S
Fuglebaevej 3D
DK-2770 Kastrup.
Denmark

Tel: +45 36 34 03 00
Fax: +45 36 77 02 42

EUROPE

Benzler TBA BV
Jachthavenweg 2
NL-5928 NT Venlo

Netherlands & the rest of Europe
Tel: +31 77 324 59 00
Fax: +31 77 324 59 01

Austria
Tel: +43 7 229 618 91
Fax: +43 7 229 618 84

Germany
Tel: 0800 350 40 00
Fax: 0800 350 40 01

FINLAND

Oy Benzler AB
Vanha Talvitie 3C
FI-00580 Helsingfors,
Finland

Tel: +358 9 340 1716
Fax: +358 9 340 1761

FRANCE

Weco Transmissions SA

Tel: +333 8937 0113
Fax: +333 8937 3936

ITALY

David Brown Hydraulics Italia S.R.L.
Via Del Costruttore, 64
41058 - Vignola (MO)
Italy

Tel: +39 059 770 0411
Fax: +39 059 770 0425

SOUTH AFRICA

David Brown Gear Industries Ltd
12 Birmingham Street,
Benoni Industrial
1500
South Africa

Tel: +27 11 748 0000
Fax: +27 11 421 2553

SWEDEN & NORWAY

AB Benzlers
Box 922 (Landskronavagen 1)
251 09 Helsingborg
Sweden

Tel: +46 42 18 68 00
Fax: +46 42 21 88 03

THAILAND

David Brown (Thailand) Ltd
700/43 Moo 6
Amata Nakorn Industrial Estate
Tumbol Klongtumru
Muang,
Chonburi
20000
Thailand

Tel: +66 3845 9044
Fax: +66 3821 3655

UNITED KINGDOM

David Brown Gear Systems Ltd
Park Road
Lockwood, Huddersfield
West Yorkshire. HD4 5DD

Tel: +44 (0) 1484 465 610
Fax: +44 (0) 1484 465 586

USA

Cone Drive
240 East 12th Street
Traverse City
Michigan
49684
USA

Tel: +01 888 994 2663
Fax: +01 888 907 2663



BENZLERS



DAVID BROWN