

DIGITAL SERVO DRIVE  
FOR BRUSHLESS/BRUSH MOTORS

### Feedback Versions

- Analog Sin/Cos
- Quad A/B digital

### Control Modes

- Indexer, Point-to-Point, PVT
- Camming, Gearing, Position, Velocity, Torque

### Command Interface

- CANopen
- ASCII and discrete I/O
- Stepper commands
- $\pm 10V$  position/velocity/torque command
- PWM position\*/velocity/torque command
- Master encoder (Gearing/Camming)

### Communications

- CANopen
- RS-232

### Feedback

- Digital Quad A/B encoder
- Secondary encoder / emulated encoder out
- Brushless resolver (-R versions)
- Analog sin/cos encoder (-S versions)
- Digital Halls

### I/O - Digital

- 9 inputs, 4 outputs

### Dimensions: mm [in]

- 97 x 64 x 33 [3.8 x 2.5 x 1.3]

\* ACJ-R models

CANopen®



Model *	Vdc	Ic	Ip
ACJ-055-09	20-55	3	9
ACJ-055-18	20-55	6	18
ACJ-090-03	20-90	1	3
ACJ-090-09	20-90	3	9
ACJ-090-12	20-90	6	12

\* Note: Add "-S" to part number for Sin/Cos version  
Add "-R" to part number for resolver version

## DESCRIPTION

Accelnet Micro Panel is a compact, DC powered servo drive for position, velocity, and torque control of AC brushless and DC brush motors. It can operate on a distributed control network, as a stand-alone indexing drive, or with external motion controllers. Standard feedback is digital quad A/B encoder and two option versions are available to support brushless resolver (-R), or analog sin/cos encoders (-S).

Indexing mode enables simplified operation with PLC's which use outputs to select and launch indexes and inputs to read back drive status. Additionally, a PLC can send ASCII data that can change motion profiles so that one index can perform various motions as machine requirements change.

The CANopen distributed control architecture is also supported. As a CAN node operating under the CANopen protocol, it supports Profile Position, Profile Velocity, Profile Torque, Interpolated Position, and Homing. Up to 127 drives can operate on a single CAN bus and groups of drives can be linked via the CAN so that they execute motion profiles together.

Operation with external motion controllers is possible in torque (current), velocity, and position modes. Input command signals can be  $\pm 10V$  (torque, velocity, position), PWM/Polarity (torque, velocity), or stepper format (CU/CD or Step/Direction).

## GENERAL SPECIFICATIONS

Test conditions: Load = Wye connected load: 2 mH + 2 Ω line-line. Ambient temperature = 25°C, +HV = HV<sub>max</sub>

MODEL	ACJ-055-09	ACJ-055-18	ACJ-090-03	ACJ-090-09	ACJ-90-12	
<b>OUTPUT POWER</b>						
Peak Current	9 (6.36)	18 (12.73)	3 (2.12)	9 (6.36)	12 (8.5)	Adc (Arms, sinusoidal), ±5%
Peak time	1	1	1	1	1	Sec
Continuous current	3 (2.12)	6 (4.24)	1 (0.71)	3 (2.12)	6 (4.24)	Adc (Arms, sinusoidal), ±5%
Peak Output Power	490	970	270	800	1600	W
Continuous "	163	323	89	267	533	W
Output resistance	0.075	0.075	0.075	0.036	0.075	Rout (Ω)
Maximum Output Voltage	Vout = HV*0.97 - Rout*Iout					
<b>INPUT POWER</b>						
HV <sub>min</sub> to HV <sub>max</sub>	20-55	20-55	20-90	20-90	20-90	+Vdc, Transformer-isolated
I <sub>peak</sub>	9	18	3	9	12	Adc (1 sec) peak
I <sub>cont</sub>	3	6	1	3	6	Adc continuous
Aux HV	20-HVmax +Vdc @ 500 mAdc maximum					
<b>PWM OUTPUTS</b>						
Type	3-phase MOSFET inverter, 15 kHz center-weighted PWM, space-vector modulation					
PWM ripple frequency	30 kHz					
<b>DIGITAL CONTROL</b>						
Digital Control Loops	Current, velocity, position. 100% digital loop control Dual loop position control using secondary encoder input					
Sampling rate (time)	Current loop: 15 kHz (66.7 us) Velocity, position loops: 3 kHz (333 us)					
Commutation	Sinusoidal field-oriented control or trapezoidal from Halls for brushless motors					
Modulation	Center-weighted PWM with space-vector modulation					
Bandwidths	Current loop: 2.5 kHz typical, bandwidth will vary with tuning & load inductance					
HV Compensation	Changes in bus voltage do not affect bandwidth					
Minimum load inductance	200 μH line-line					
<b>COMMAND INPUTS</b>						
CANopen	Profile Position, Interpolated Position, Profile Velocity, Profile Torque, Homing					
Digital position	Step/Direction, CW/CCW			Stepper commands (2 MHz maximum rate)		
	Quad A/B Encoder			20 Mcount/sec (after quadrature), 5 Mline/sec		
Digital position*/velocity/torque	PWM, Polarity			PWM = 0~100%, Polarity = 1/0		
* Resolver models (-R)	PWM			PWM = 50% ±50%, no polarity signal required		
	PWM frequency range			1 kHz minimum, 100 kHz maximum		
	PWM minimum pulse width			220 ns		
Analog torque/velocity/position	±10 Vdc, 5 kΩ differential input impedance					
<b>DIGITAL INPUTS</b>						
Number, type	9, non-isolated. [IN1] dedicated to Drive Enable function, [IN2]~[IN9] are programmable					
All inputs	74HC14 Schmitt trigger operating from +5 Vdc with RC filter on input 10 kΩ to +5 Vdc or ground for all except [IN5] (see below)					
Logic levels	Vin-LO < 1.35 Vdc, Vin-HI > 3.65 Vdc					
Pull-up, pull-down control	All inputs have group selectable connection of input pull-up/down resistor to +5 Vdc, or ground					
Enable [IN1]	1 Dedicated input with 330 μs RC filter for drive enable, 0 to +24 Vdc max					
GP [IN2,3,4]	3 General Purpose inputs with 330 μs RC filter, 0 to +24 Vdc max					
MS [IN5]	1 Medium-Speed input for motor temperature switch, 33 μs RC filter, 4.99 kΩ pullup/pulldown, 0 to +24 Vdc max					
HS [IN6,7,8,9]	4 High-Speed Inputs inputs with 100 ns RC filter, 0 to +5 Vdc max					
<b>DIGITAL OUTPUTS (NOTE 1)</b>						
Number, type	4, non-isolated, programmable					
[OUT1~4],	Current-sinking MOSFET with 1 kΩ pullup to +5 Vdc through diode					
Current rating	300 mAdc max, +30 Vdc max. Functions programmable External flyback diode required if driving inductive loads					
<b>MULTI-MODE ENCODER PORT</b>						
Operation	Operates as an input or output depending on drive Basic Setup					
Signals	Digital: A, /A, B, /B, X, /X					
As Input	26C32 differential line receivers (for operation as an encoder input port)					
As Output	26C31 differential line drivers (for operation as buffered encoder outputs)					
Frequency	20 MHz (post-quadrature)					
<b>RS-232 PORT</b>						
Signals	RxD, TxD, Gnd					
Mode	Full-duplex, serial communication port for drive setup and control, 9,600 to 115,200 baud					
Protocol	Binary or ASCII formats					
<b>CAN PORTS</b>						
Signals	CANH, CANL, Gnd					
Isolation	CAN interface circuit and +5 Vdc supply for CAN is optically isolated from drive circuits					
Format	CAN V2.0b physical layer for high-speed connections compliant					
Data	CANopen Device Profile DSP-402					
Address selection	Programmable to flash memory or determined by digital inputs					

## FEEDBACK

### DIGITAL QUAD A/B ENCODER

Type	Quadrature, differential line driver outputs
Signals	A, /A, B, /B, (X, /X, index signals optional)
Frequency	5 MHz line frequency, 20 MHz quadrature count frequency

### ANALOG ENCODER (-S OPTION)

Type	Sin/cos, differential line driver outputs, 0.5 V <sub>peak-peak</sub> (1.0 V <sub>peak-peak</sub> differential) centered about 2.5 V <sub>dc</sub> typical. Common-mode voltage 0.25 to 3.75 V <sub>dc</sub>
Signals	Sin(+), sin(-), cos(+), cos(-)
Frequency	230 kHz maximum line (cycle) frequency
Interpolation	10 bits/cycle (1024 counts/cycle)

### RESOLVER (-R OPTION)

Type	Brushless, single-speed, 1:1 to 2:1 programmable transformation ratio
Resolution	14 bits (equivalent to a 4096 line quadrature encoder)
Reference frequency	7.5 kHz
Reference voltage	2.8 V <sub>rms</sub> , auto-adjustable by the drive to maximize feedback
Reference maximum current	100 mA
Maximum RPM	10,000+

### ENCODER EMULATION

Resolution	Programmable to 16,384 counts/rev (4096 line encoder equivalent)
Buffered encoder outputs	26C31 differential line driver

### DIGITAL HALLS

Type	Digital, single-ended, 120° electrical phase difference
Signals	U, V, W
Frequency	Consult factory for speeds >10,000 RPM

### ENCODER POWER SUPPLY

Power Supply	+5 V <sub>dc</sub> @ 400 mA to power encoders & Halls
Protection	Current-limited to 750 mA @ 1 V <sub>dc</sub> if overloaded Encoder power developed from +24 V <sub>dc</sub> so position information is not lost when AC mains power is removed

### MOTOR CONNECTIONS

Phase U, V, W	PWM outputs to 3-ph. ungrounded Wye or delta wound brushless motors, or DC brush motors
Hall U, V, W	Digital Hall signals, single-ended
Digital Encoder	Digital quadrature encoder signals, differential (X or Index signal not required) 5 MHz maximum line frequency (20 Mcounts/sec) 26C32 differential line receiver with 121 Ω terminating resistor between complementary inputs
Analog Encoder	Analog sin/cos signals, 1 V <sub>p-p</sub> , differential
Hall & encoder power	+5 V <sub>dc</sub> ±2% @ 400 mA <sub>dc</sub> max
Motemp [IN 5]	Motor overtemperature sensor switch input Programmable to disable drive when motor over-temperature condition occurs
Brake	[OUT1~4] are programmable for motor brake function, external flyback diode required

### STATUS INDICATORS

Drive Status	Bicolor LED, drive status indicated by color, and blinking or non-blinking condition
CAN Status	Bicolor LED, status of CAN bus indicated by color and blink codes to CAN Indicator Specification 303-3

### PROTECTIONS

HV Overvoltage	HV > +56, +91 V <sub>dc</sub>	Drive outputs turn off until +HV < overvoltage (for 55, 90 V <sub>dc</sub> models)
HV Undervoltage	HV < +14 V <sub>dc</sub>	Drive outputs turn off until +HV ≥ +14 V <sub>dc</sub>
Drive over temperature	Heat plate > 70°C	Drive outputs turn off, latching fault
Short circuits		Output to output, output to ground, internal PWM bridge faults
I <sup>2</sup> T Current limiting		Programmable: continuous current, peak current, peak time
Motor over temperature		Digital inputs programmable to detect motor temperature switch
Functions		Fault conditions are programmable as latching or non-latching types

### MECHANICAL & ENVIRONMENTAL

Size	3.83 x 2.47 x 1.29 in. (97.28 x 62.74 x 32.77 mm)
Weight	4.8 oz, 0.14 kg
Ambient temperature	0 to +45 °C operating, -40 to +85 °C storage
Humidity	0 to 95%, non-condensing
Vibration	2 g peak, 10~500 Hz (sine), IEC60068-2-6
Shock	10 g, 10 ms, half-sine pulse, IEC60068-2-27
Contaminants	Pollution degree 2
Environment	IEC68-2: 1990
Cooling	Conduction through heatplate on drive chassis, or convection

### AGENCY CONFORMANCE

EN 55011 : 1998	CISPR 11 (1997) Edition 2/Amendment 2: Limits and Methods of Measurement of Radio Disturbance Characteristics of Industrial, Scientific, and Medical (ISM) Radio Frequency Equipment
EN 61000-6-1 : 2001	Electromagnetic Compatibility Generic Immunity Requirements <i>Following the provisions of EC Directive 89/336/EEC:</i>
EN 61010-1 2nd Ed.: 2001	Safety Requirements for Electrical Equipment for Measurement, Control, and Laboratory use <i>Following the provisions of EC Directive 2006/95/EC:</i>
UL 508C 3rd Ed.: 2002	UL Standard for Safety for Power Conversion Equipment

## CME 2™ SOFTWARE

Amplifier setup is fast and easy using CME 2™ software which communicates with the amplifier over CAN or an RS-232 link. All of the operations needed to configure the amplifier are accessible through this powerful and intuitive program. Auto-phasing of brushless motor Hall sensors and phase wires eliminates “wire and try”. Connections are made once and CME 2™ does the rest thereafter. Encoder wire swapping to establish the direction of positive motion is eliminated.

Motor data can be saved as .ccm files. Amplifier data is saved as .ccx files that contain all amplifier settings plus motor data. This eases system management as files can be cross-referenced to amplifiers. Once an amplifier configuration has been completed systems can be replicated easily with the same setup and performance.

## RS-232 COMMUNICATIONS

The serial-port is three-wire (RxD,TxD, Gnd), full-duplex RS-232 that operates from 9600 to 115,200 Baud. Connections to the RS-232 port are through J5, the Signal connector. The *Accelnet Micro Panel* Serial Cable Kit (ACJ-SK) contains a 9-pin female Sub-D serial port (COM1, COM2, etc.) connector and 2m (6 ft.) cable that is terminated in a J5 cable connector. This provides an easy connection to the amplifier for set-up without wiring to J5.

## AMP STATUS LED

A bi-color LED gives the status of the amplifier by changing color, and either blinking or remaining solid. The possible color and blink combinations are:

- **Green/Solid:** Amplifier OK and enabled. Will run in response to reference inputs or CANopen commands.
- **Green/Slow-Blinking:** Amplifier OK but NOT-enabled. Will run when enabled.
- **Green/Fast-Blinking:** Positive or Negative limit switch active. Amplifier will only move in direction not inhibited by limit switch.
- **Red/Solid:** Transient fault condition. Amplifier will resume operation when fault is removed.
- **Red/Blinking:** Latching fault. Operation will not resume until amp is Reset

Fault conditions:

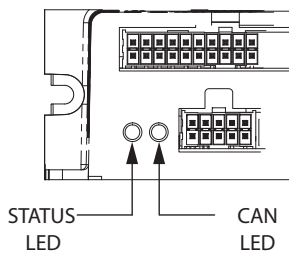

- Over or under-voltage
- Motor over-temperature
- Phasing error (current position is > 60° electrical from Hall angle)
- Short-circuits from output to output
- Short-circuits from output to ground
- Internal short circuits
- Amplifier over-temperature
- Position-mode following error

Faults are programmable to be either transient or latching

## CANOPEN NETWORKING

Based on the CAN V2.0b physical layer, a robust, two-wire communication bus originally designed for automotive use where low-cost and noise-immunity are essential, CANopen adds support for motion-control devices and command synchronization. The result is a highly effective combination of data-rate and low cost for multi-axis motion control systems. Device synchronization enables multiple axes to coordinate moves as if they were driven from a single control card.

## CAN STATUS LED

The CAN status LED operates in accordance with CAN specification 303-3. This is a bi-color LED that uses red and green colors in solid, flashing, and blinking states to indicate conditions on the CAN bus.

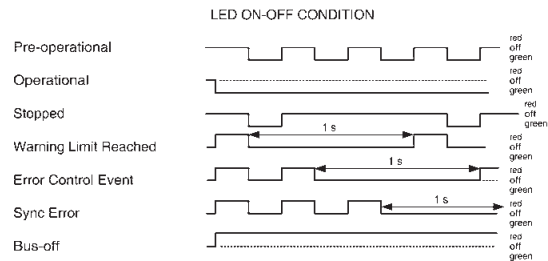

## CAN NODE ADDRESS

The node address of the ACJ can be set using digital inputs or saved in flash memory. The default configuration is to assign inputs [IN6,7,8,9] as CAN address bits. [IN6] is the LSB of a 4-bit address and [IN9] is the MSB. These inputs are programmed as a group to pull-down to ground giving a default node address of 0. Connecting any of these inputs to +5 Vdc gives a logical value of 1.

The CAN address of 0 is reserved for the CAN bus master and cannot be used when the drives are operating on a CAN bus. When set up for ASCII Multi-Drop, however, the master drive must have address 0.

The table below shows some examples of input configurations and the hex and decimal addresses that result. The default address is 0. For CANopen operation this is reserved for the bus controller. For multi-drop ASCII, the drive that takes the serial port cable must be address 0, and the other drives daisy-chaining from that via CAN cables should have non-zero addresses.

3	2	1	0	Address Bits	
[IN9]	[IN8]	[IN7]	[IN6]	Hex	Dec
0	0	0	0	0x0	0
0	0	0	1	0x1	1
0	0	1	0	0x2	2
0	0	1	1	0x3	3
0	1	0	0	0x4	4
0	1	0	1	0x5	5
0	1	1	0	0x6	6
0	1	1	1	0x7	7
1	0	0	0	0x8	8
1	0	0	1	0x9	9
1	0	1	0	0xA	10
1	0	1	1	0xB	11
1	1	0	0	0xC	12
1	1	0	1	0xD	13
1	1	1	0	0xE	14
1	1	1	1	0xF	15

**COMMAND INPUTS IN STAND-ALONE MODE**

The command inputs control the drive to produce an output and are used when the drive is taking current, velocity, or position commands from an external controller in stand-alone mode. The command inputs take digital and analog signals in a variety of formats:

*Current or Velocity Mode*

- ±10V Analog
- PWM/Direction, PWM 50%

*Position Mode*

- ±10V Analog
- CU/CD, Step/Direction
- Master Encoder, A/B Quadrature
- PWM/Direction, PWM 50% (-R models)

For current or velocity control, the PWM/Direction format takes a PWM signal at constant frequency which changes its' duty cycle from 0 to 100% to control current or velocity and a DC level at the Direction input to control polarity. The PWM 50% format takes a single PWM signal that produces 0 output at 50% duty cycle, and maximum positive/negative outputs at 0% or 100%. As a protection against wiring faults, the 0% and 100% inputs can be programmed to produce 0 output. When this is done the max/min duty cycle range is >0% and <100%.

Position-control inputs take signals in popular stepper-motor format or from a digital quadrature encoder. The CU/CD format moves the motor in a positive direction for each pulse received at the count-up input. Negative motion is produced by pulses on the count-down input. The step-direction mode moves the motor an increment of position for every pulse received at the pulse input while the direction of movement is controlled by a DC level on the direction input. Master encoder quadrature signals (A,B) are decoded into four counts per encoder line with the direction derived from the logic-state transitions of the inputs. In position mode the ratio of motor motion per input-count is programmable. Resolver models (-R option) also accept PWM inputs for position control. A ±10V analog command can control current, velocity, or position as well.

**POSITION\*, VELOCITY, OR TORQUE MODE REFERENCE INPUTS (\* IN -R MODELS)**

**PWM/DIRECTION INPUTS**

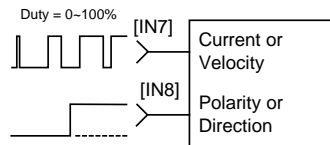

**PWM 50% INPUT**

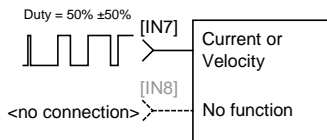

**±10 V ANALOG INPUT**

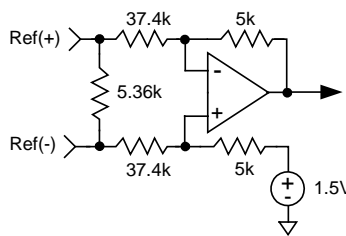

**STEP MOTOR EMULATION INPUTS**

**Pulse/Direction Inputs**

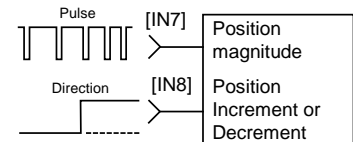

**Count-up/Count-down Inputs**

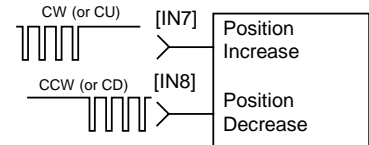

**Quad AB Encoder**

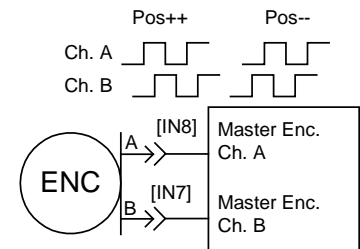

**MULTI-MODE ENCODER PORT**

This port consists of three differential input/output channels. The functions change with the drive's basic setup.

For dual-loop position-mode operation that employs a primary encoder on the motor, and a secondary encoder on the load, the port works as an input receiving the secondary encoder's quad A/B/X signals.

For stand-alone operation with an external motion controller, the signals from the digital encoder on the motor are buffered and made available at the control signal connector for transmission to the controller. This eliminates split-wired motor cables with dual connectors that take the encoder signals to both drive and controller.

As a stand-alone position controller, the port can take differential digital position commands in pulse/direction, CU/CD, or quad A/B format.

Models that take sin/cos feedback will produce emulated quad A/B signals with programmable resolution.

**FUNCTIONAL DIAGRAM OF ONE CHANNEL**

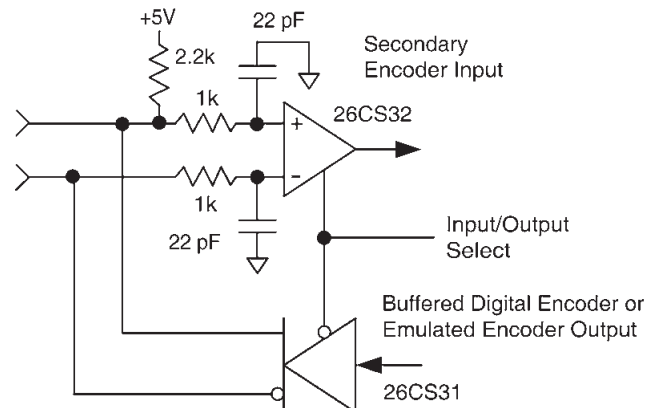



## DIGITAL INPUTS

Accelnet Micro Panel has nine digital inputs, eight of which have programmable functions. Input [IN1] is not programmable and is dedicated to the drive Enable function. This is done to prevent accidental programming of the input in such a way that the controller could not shut it down.

Two types of RC filters are used: GP (general purpose) and HS (high speed). Input functions such as Step/Direction, CU/CD, Quad A/B are wired to inputs having the HS filters, and inputs with the GP filters are used for general purpose logic functions, limit switches, and the motor temperature sensor. Programmable functions of the digital inputs include :

- Positive Limit switch
- Negative Limit switch
- Home switch
- Drive Reset
- PWM current or velocity commands
- CAN address bits
- Step & Direction, or CU/CD step motor position commands
- Quad A/B master encoder position commands
- Motor over-temperature
- Motion Profile Abort

In addition to the active level and function for each programmable input, the input resistors are programmable in three groups to either pull up to +5 Vdc, or down to ground. Grounded inputs with HI active levels interface to PLC's that have PNP outputs that source current from +24 Vdc sources. Inputs pulled up to +5 Vdc work with open-collector, or NPN drivers that sink current to ground.

### GP INPUTS 1,2,3 24 Vdc max

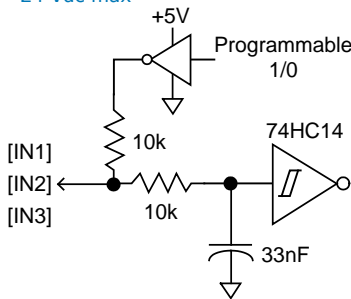

### GP INPUTS 4,5 24 Vdc max

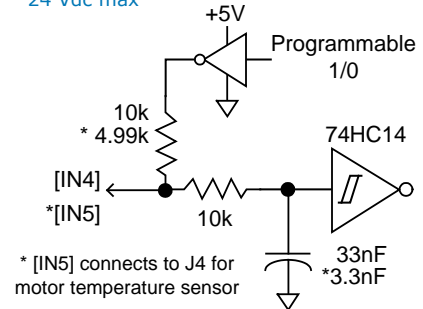

### HS INPUTS 6,7,8,9 5 Vdc max

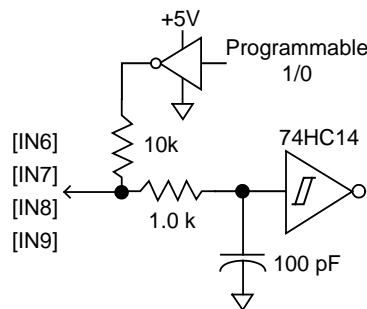

## DIGITAL OUTPUTS

Digital outputs are open-drain MOSFETs with 1 kΩ pull-up resistors to +5 Vdc. These can sink up to 100 mA from external loads operating from power supplies to +30 Vdc. When driving inductive loads such as a motor brake, an external fly-back diode is required. The diode in the output is for driving PLC inputs that are opto-isolated and connected to +24 Vdc. The diode prevents conduction from +24 Vdc through the 1 kΩ resistor to +5 Vdc in the drive. This could turn the input on, giving a false indication of the drive output state.

These outputs are programmable to be on or off when active. Typical functions are drive fault indication or motor brake operation. Other functions are programmable.

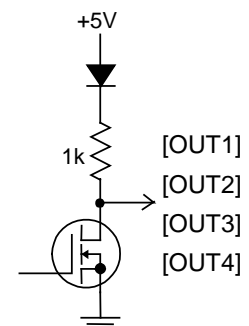

## GROUNDING CONSIDERATIONS

Power and control circuits share a common circuit-ground (HV Gnd on J3-4, and Signal Ground on J2-5, J4-6 & 11, J5-2,9,15,17, and 28). Input logic circuits are referenced to Signal Ground, as are analog Reference inputs, digital outputs, encoder and Hall signals. For this reason, drive Gnd terminals should connect to the users' ground system so that signals between drive and controller are at the same common potential, and to minimize noise. The system ground should, in turn, connect to an earthing conductor at some point so that the whole system is referenced to "earth". The CAN ports are optically isolated from the drive circuits.

Because current flow through conductors produces voltage-drops across them, it is best to connect the drive HV Return to system earth, or circuit-common through the shortest path, and to leave the power-supply floating. In this way, the power supply (-) terminal connects to ground at the drive HV Return terminals, but the voltage drops across the cables will not appear at the drive ground, but at the power supply negative terminal where they will have less effect.

Motor phase currents are balanced, but currents can flow between the PWM outputs, and the motor cable shield. To minimize the effects of these currents on nearby circuits, the cable shield should connect to Gnd (J2-5).

The drive heatplate does not connect to any drive circuits. Cables must be shielded for CE compliance, and the shields should connect to the Frame Ground terminals. When installed, the drive heatplate should connect to the system chassis. This maximizes the shielding effect, and provides a path to ground for noise currents that may occur in the cable shields.

Signals from controller to drive are referenced to +5 Vdc, and other power supplies in user equipment. These power supplies should also connect to system ground and earth at some point so that they are at same potential as the drive circuits.

The final configuration should embody three current-carrying loops. First, the power supply currents flowing into and out of the drive at the +HV and Gnd pins on J3. Second the drive outputs driving currents into and out of the motor phases, and motor shield currents circulating between the U, V, and W outputs and Gnd. And, lastly, logic and signal currents connected to the drive control inputs and outputs.

For CE compliance and operator safety, the drive should be earthed by using external tooth lockwashers under the mounting screws. These will make contact with the aluminum heatplate to connect it to the equipment frame ground.

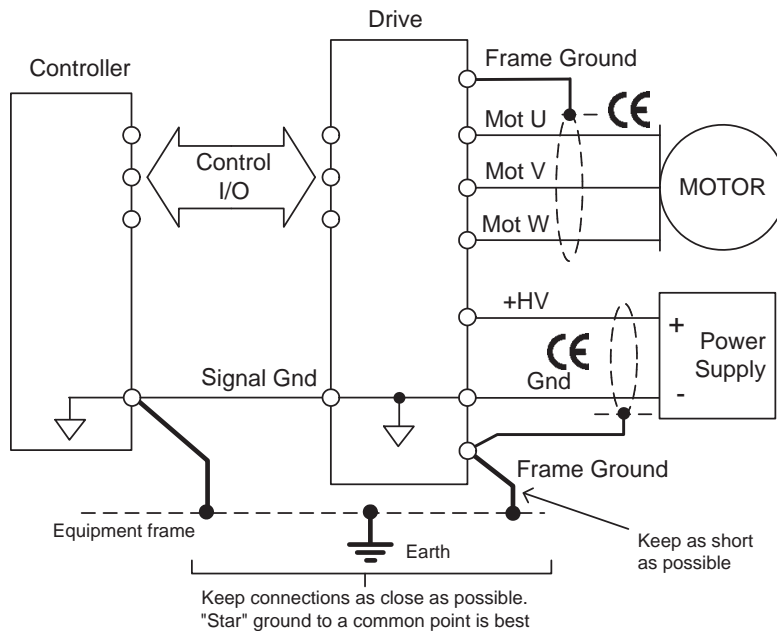

 = Shielded cables required for CE compliance

## POWER SUPPLIES

Accelnet Micro Panel operates typically from transformer-isolated, unregulated DC power supplies. These should be sized such that the maximum output voltage under high-line and no-load conditions does not exceed the drives maximum voltage rating. Power supply rating depends on the power delivered to the load by the drive. In many cases, the continuous power output of the drive is considerably higher than the actual power required by an incremental motion application.

Operation from regulated switching power supplies is possible if a diode is placed between the power supply and drive to prevent regenerative energy from reaching the output of the supply. If this is done, there must be external capacitance between the diode and drive. Distance between this capacitor and the drive should be 1 metre or less.

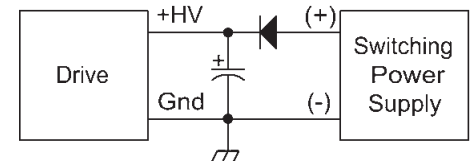

## AUXILIARY HV POWER

Accelnet Micro Panel has an input for AUX HV. This is a voltage that can keep the drive communications and feedback circuits active when the PWM output stage has been disabled by removing the main +HV supply. This can occur during EMO (Emergency Off) conditions where the +HV supply must be removed from the drive and powered-down to ensure operator safety. The AUX HV input operates from any DC voltage that is within the operating voltage range of the drive and powers the DC/DC converter that supplies operating voltages to the drive DSP and control circuits.

When the drive +HV voltage is greater than the AUX-HV voltage it will power the DC/DC converter. Under these conditions the AUX-HV input will draw no current.

## MOUNTING & COOLING

Accelnet Micro Panel has slots for mounting to panels at 0° or 90°. Cooling is by conduction from drive heatplate to mounting surface, or by convection to ambient.

MOTOR CONNECTIONS

Motor connections are of four types: phase, Halls, encoder and thermal sensor. The phase connections carry the drive output currents that drive the motor to produce motion. The Hall signals are three digital signals that give absolute position feedback within an electrical commutation cycle. The encoder signals give incremental position feedback and are used for velocity and position modes, as well as sinusoidal commutation. A thermal sensor that indicates motor overtemperature is used to shut down the drive to protect the motor.

DIGITAL MOTOR ENCODER

The input circuit for the motor encoder signals is a differential line-receiver with R-C filtering on the inputs. A 121 Ω resistor is across each input pair to terminate the signal pairs in the cable characteristic impedance. Encoders with differential outputs are required because they are less susceptible to noise that can be picked on single-ended outputs. For best results, encoder cabling should use twisted pair cable with one pair for each of the encoder outputs: A-/A, B-/B, and X-/X. Shielded twisted-pair is even better for noise rejection.

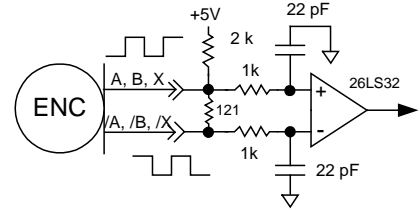

ANALOG MOTOR ENCODER

The input circuit for the motor encoder signals is a differential line-receiver with R-C filtering on the inputs. A 121 Ω resistor is across each input pair to terminate the signal pairs in the cable characteristic impedance. Encoders with differential outputs are required because they are less susceptible to noise that can be picked on single-ended outputs. For best results, encoder cabling should use twisted pair cable with one pair for each of the encoder outputs: A-/A, B-/B, and X-/X. Shielded twisted-pair is even better for noise rejection.

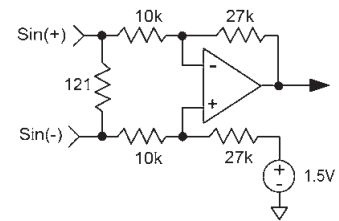

MOTOR HALL SIGNALS

Hall signals are single-ended signals that provide absolute feedback within one electrical cycle of the motor. There are three of them (U, V, & W) and they may be sourced by magnetic sensors in the motor, or by encoders that have Hall tracks as part of the encoder disc. They typically operate at much lower frequencies than the motor encoder signals, and are used for commutation-initialization after startup, and for checking the motor phasing after the drive has switched to sinusoidal commutation.

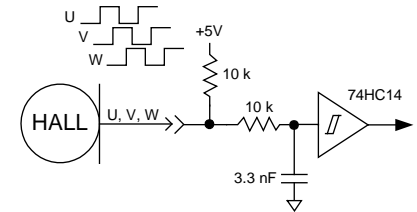

ANALOG HALLS (-S MODELS) + DIGITAL ENCODER

For position feedback with higher resolution than is possible by interpolating analog Halls, a digital incremental encoder is connected to the multi-mode port. The Halls are then used for commutation and the multi-mode port is programmed as a differential input for the Secondary Incremental motor encoder.

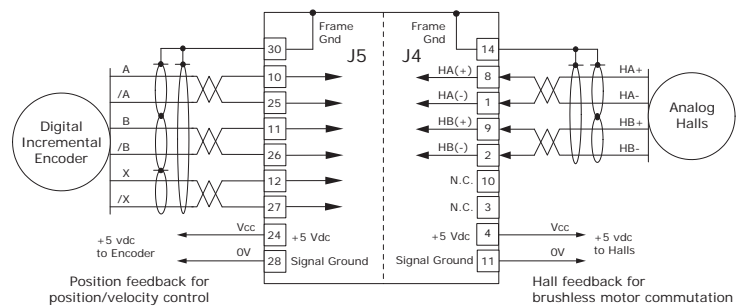

RESOLVER (-R MODELS)

Connections to the resolver should be made with shielded cable that uses three twisted-pairs. Once connected, resolver set up, motor phasing, and other commissioning adjustments are made with CME 2 software. There are no hardware adjustments.

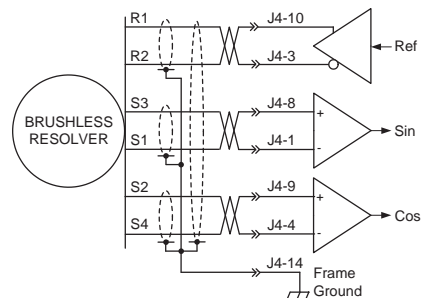

CE = Shielded cables required for CE compliance



## MOTOR PHASE CONNECTIONS

The drive output is a three-phase PWM inverter that converts the DC buss voltage (+HV) into three sinusoidal voltage waveforms that drive the motor phase-coils. Cable should be sized for the continuous current rating of the drive. Motor cabling should use twisted, shielded conductors for CE compliance, and to minimize PWM noise coupling into other circuits. The motor cable shield should connect to motor frame and the drive frame ground terminal (J2-1) for best results.

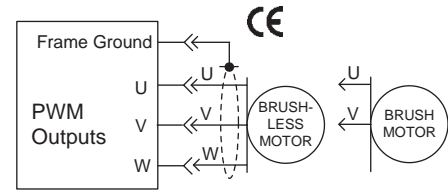

## MOTOR TEMPERATURE SENSOR

Digital input [IN5] is for use with a motor overtemperature switch. The input should be programmed as a pull-up to +5 Vdc if the motor switch is grounded when cold, and open or high-impedance when over-heating.

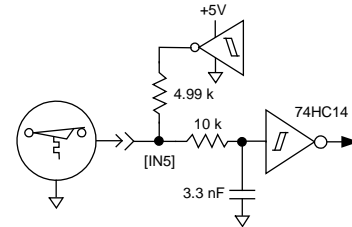

## MOTOR BRAKE

Digital outputs [OUT1,2,3,4] can be programmed to power a motor-mounted brake. These brake the motor when they are in an unpowered state and must have power applied to release. This provides a fail-safe function that prevents motor motion if the system is in an unpowered (uncontrolled) state. Because brakes are inductive loads, an external flyback diode must be used to control the coil voltage when power is removed. The timing of the brake is programmable.

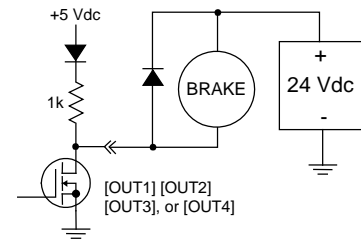

## ACJ-FC-10 FEEDBACK CABLE ASSEMBLY

Color	Pin		Color
Blue	8	1	Black
White	9	2	Black
Orange	10	3	Black
Black	11	4	Red
Brown	12	5	Black
Yellow	13	6	Black
Green	14	7	Black

This cable plugs into amplifier J4 and consists of seven twisted-pairs of AWG 24 wire. Each pair has a black and colored conductor. The chart above shows twisted-pairs in the rows. E.g. one pair goes to pins 1&8, another pair to pins 2&9, etc. Cable termination is flying leads for connection to customer motor feedback encoder.

## ACJ-NC-10 & ACJ-NC-01 CANOPEN CABLE ASSEMBLIES

Color	Pin		Color
N/C	6	1	N/C
N/C	7	2	White/Orange
N/C	8	3	Orange
N/C	9	4	White/Green
N/C	10	5	N/C

These cables connect to amplifier J1 and have 3 conductors of AWG 24 wire that are terminated in contacts that can then be inserted into pins 7~9 of another ACJ-NC-10 to "daisy chain" the CAN signals to multiple amplifiers.

## CONNECTORS & SIGNALS

Conductor ratings for contacts (when used with crimping tools shown below):  
 Samtec CC79L-2024-01-F: AWG 24~20 wire, insulation diameter .035" (0.89mm) - .070" (1.78mm)  
 Molex 39-00-0039: AWG 24~18 wire, insulation diameter .051" (1.30mm) - .122" (3.10mm)

**J4 Cable Connector:**  
 14-position poke/crimp  
 Housing: Samtec IPD1-07-D  
 Contacts(14): Samtec CC79L-2024-01-F  
 Crimping tool: Samtec CAT-HT-179-2024-11  
 Contact Extractor: Samtec CAT-EX-179-01

J4 Feedback			
Signal	Pin	Pin	Signal
Encoder A	8	1	Encoder /A
Encoder B	9	2	Encoder /B
Encoder X	10	3	Encoder /X
Signal Ground	11	4	Encoder +5 Vdc
Hall V	12	5	Hall U
Hall W	13	6	Signal Ground
Frame Ground	14	7	Motemp [IN5]

J5 Signal			
Signal	Pin	Pin	Signal
Analog Ref (-)	16	1	Analog Ref (+)
Signal Ground	17	2	Signal Ground
Programmable Input [IN2]	18	3	Enable Input [IN1]
Programmable Input [IN4]	19	4	Programmable Input [IN3]
Programmable Input [IN7]	20	5	Programmable Input [IN6]
Programmable Input [IN9]	21	6	Programmable Input [IN8]
Programmable Output [OUT2]	22	7	Programmable Output [OUT1]
Programmable Output [OUT4]	23	8	Programmable Output [OUT3]
Encoder +5 Vdc	24	9	Signal Ground
Bi-Mode Encoder /A	25	10	Bi-Mode Encoder A
Bi-Mode Encoder /B	26	11	Bi-Mode Encoder B
Bi-Mode Encoder /X	27	12	Bi-Mode Encoder X
Signal Ground	28	13	Signal Ground
RS-232 TxD	29	14	RS-232 RxD
Frame Ground	30	15	Signal Ground

**J5 Cable Connector:**  
 30-position poke/crimp  
 Housing: Samtec IPD1-15-D  
 Contacts(30): Samtec CC79L-2024-01-F  
 Crimping tool: Samtec CAT-HT-179-2024-11  
 Contact Extractor: Samtec CAT-EX-179-01

**J3 Cable Connector:**  
 4-position poke/crimp  
 Housing: Molex 39-01-4041  
 Contacts: Molex 39-00-0039  
 Crimping Tool: Molex 11-01-0197  
 Extractor Tool: Molex 11-03-0044

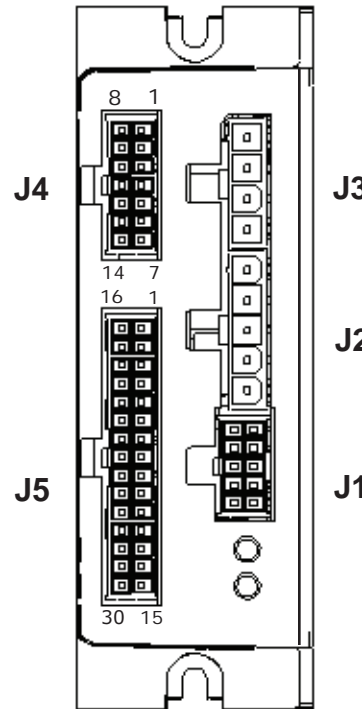

J3 Power	
Pin	Signal
1	Frame Ground
2	Aux HV
3	+HV
4	HV Ground

J2 Motor	
Pin	Signal
1	Frame Ground
2	Motor W
3	Motor V
4	Motor U
5	Signal Ground

**J2 Cable Connector:**  
 5-position poke/crimp  
 Housing: Molex 39-01-4051  
 Contact: Molex 39-00-0039  
 Crimping Tool: Molex 11-01-0197  
 Extractor Tool: Molex 11-03-0044

CAN circuits are isolated from drive circuits

J1 CAN			
Signal	Pin	Pin	Signal
CAN Power	6	1	CAN Power
CANH	7	2	CANH
CANL	8	3	CANL
Signal Ground	9	4	Signal Ground
Frame Ground	10	5	Frame Ground

**J1 Cable Connector:**  
 10-position poke/crimp  
 Housing: Samtec IPD1-05-D  
 Contacts(10): Samtec CC79L-2024-01-F  
 Crimping tool: Samtec CAT-HT-179-2024-11  
 Contact Extractor: Samtec CAT-EX-179-01

## DRIVE CONNECTIONS

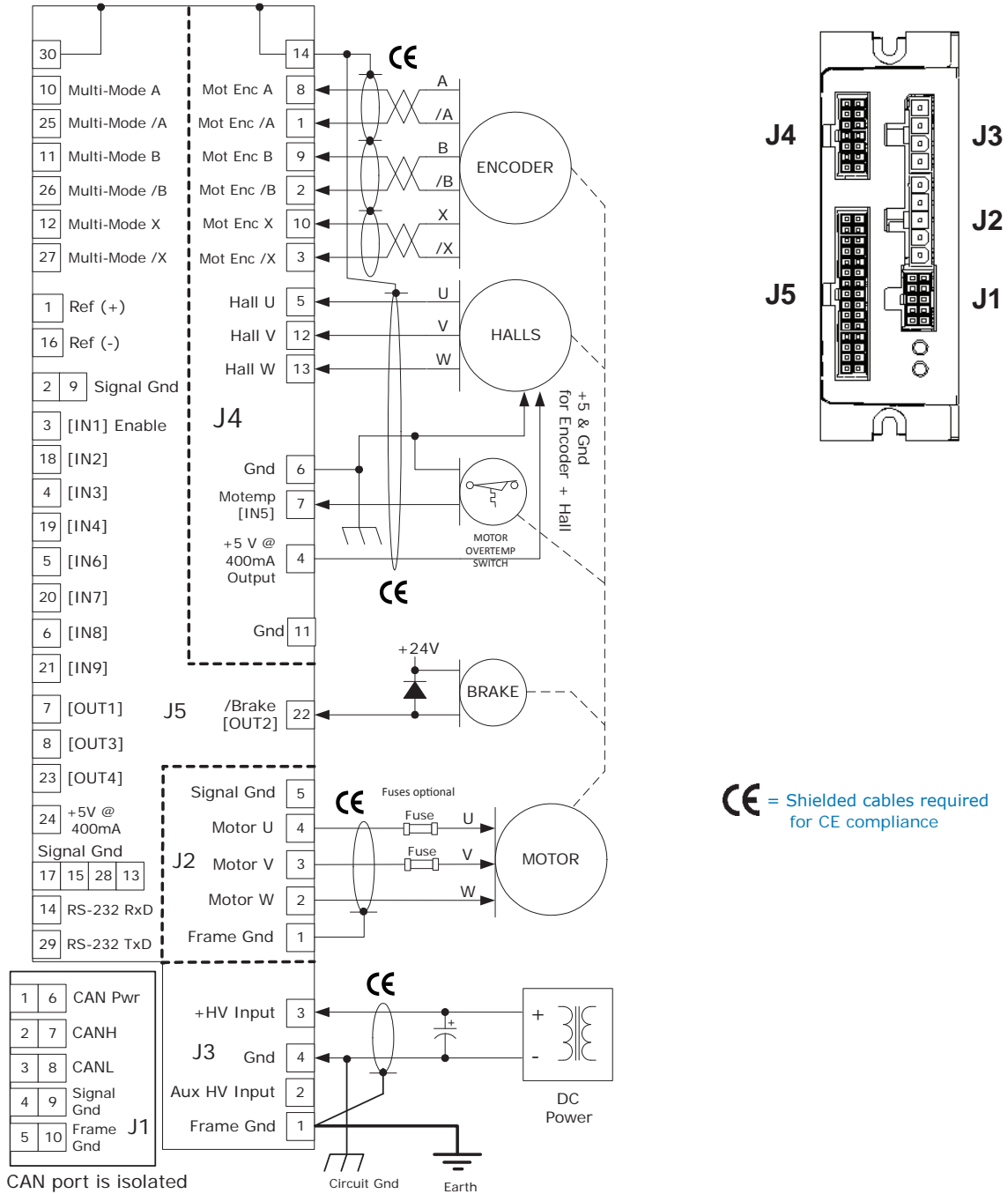

CAN port is isolated

### NOTES

1. The functions of input signals on J4-7 and J5-3,4,5,6,18,19,20, and 21 are programmable.
2. The function of [IN1] on J5-3 is always Drive Enable and is not programmable. The active level of [IN1] is programmable, and resetting the drive with changes on the enable input is programmable.
3. Pins J4-4 and J5-24 connect to the same +5 Vdc @ 400 mAdc power source. Total current drawn from both pins cannot exceed 400 mAdc.
4. Pins 5 & 10 of CAN port on J1 connect to frame ground for cable shield. All other CAN port pins are isolated from drive circuits.

## CONNECTORS & SIGNALS

Conductor ratings for contacts (when used with crimping tools shown below):  
 Samtec CC79L-2024-01-F: AWG 24~20 wire, insulation diameter .035" (0.89mm) - .070" (1.78mm)  
 Molex 39-00-0039: AWG 24~18 wire, insulation diameter .051" (1.30mm) - .122" (3.10mm)

**J4 Cable Connector:**  
 14-position poke/crimp  
 Housing: Samtec IPD1-07-D  
 Contacts(14): Samtec CC79L-2024-01-F  
 Crimping tool: Samtec CAT-HT-179-2024-11  
 Contact Extractor: Samtec CAT-EX-179-01

**J3 Cable Connector:**  
 4-position poke/crimp  
 Housing: Molex 39-01-4041  
 Contacts: Molex 39-00-0039  
 Crimping Tool: Molex 11-01-0197  
 Extractor Tool: Molex 11-03-0044

J4 Feedback			
Signal	Pin	Pin	Signal
Sin(+)	8	1	Sin(-)
Cos(+)	9	2	Cos(-)
Encoder X	10	3	Encoder /X
Signal Ground	11	4	Encoder +5 Vdc
Hall V	12	5	Hall U
Hall W	13	6	Signal Ground
Frame Ground	14	7	Motemp [IN5]

J5 Signal			
Signal	Pin	Pin	Signal
Analog Ref (-)	16	1	Analog Ref (+)
Signal Ground	17	2	Signal Ground
Programmable Input [IN2]	18	3	Enable Input [IN1]
Programmable Input [IN4]	19	4	Programmable Input [IN3]
Programmable Input [IN7]	20	5	Programmable Input [IN6]
Programmable Input [IN9]	21	6	Programmable Input [IN8]
Programmable Output [OUT2]	22	7	Programmable Output [OUT1]
Programmable Output [OUT4]	23	8	Programmable Output [OUT3]
Encoder +5 Vdc	24	9	Signal Ground
Bi-Mode Encoder /A	25	10	Bi-Mode Encoder A
Bi-Mode Encoder /B	26	11	Bi-Mode Encoder B
Bi-Mode Encoder /X	27	12	Bi-Mode Encoder X
Signal Ground	28	13	Signal Ground
RS-232 TxD	29	14	RS-232 RxD
Frame Ground	30	15	Signal Ground

**J5 Cable Connector:**  
 30-position poke/crimp  
 Housing: Samtec IPD1-15-D  
 Contacts(30): Samtec CC79L-2024-01-F  
 Crimping tool: Samtec CAT-HT-179-2024-11  
 Contact Extractor: Samtec CAT-EX-179-01

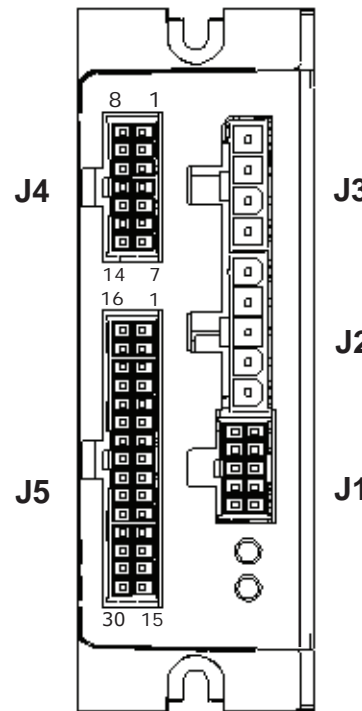

J3 Power	
Pin	Signal
1	Frame Ground
2	Aux HV
3	+HV
4	HV Ground

J2 Motor	
Pin	Signal
1	Frame Ground
2	Motor W
3	Motor V
4	Motor U
5	Signal Ground

**J2 Cable Connector:**  
 5-position poke/crimp  
 Housing: Molex 39-01-4051  
 Contact: Molex 39-00-0039  
 Crimping Tool: Molex 11-01-0197  
 Extractor Tool: Molex 11-03-0044

CAN circuits are isolated from drive circuits

J1 CAN			
Signal	Pin	Pin	Signal
CAN Power	6	1	CAN Power
CANH	7	2	CANH
CANL	8	3	CANL
Signal Ground	9	4	Signal Ground
Frame Ground	10	5	Frame Ground

**J1 Cable Connector:**  
 10-position poke/crimp  
 Housing: Samtec IPD1-05-D  
 Contacts(10): Samtec CC79L-2024-01-F  
 Crimping tool: Samtec CAT-HT-179-2024-11  
 Contact Extractor: Samtec CAT-EX-179-01

## DRIVE CONNECTIONS

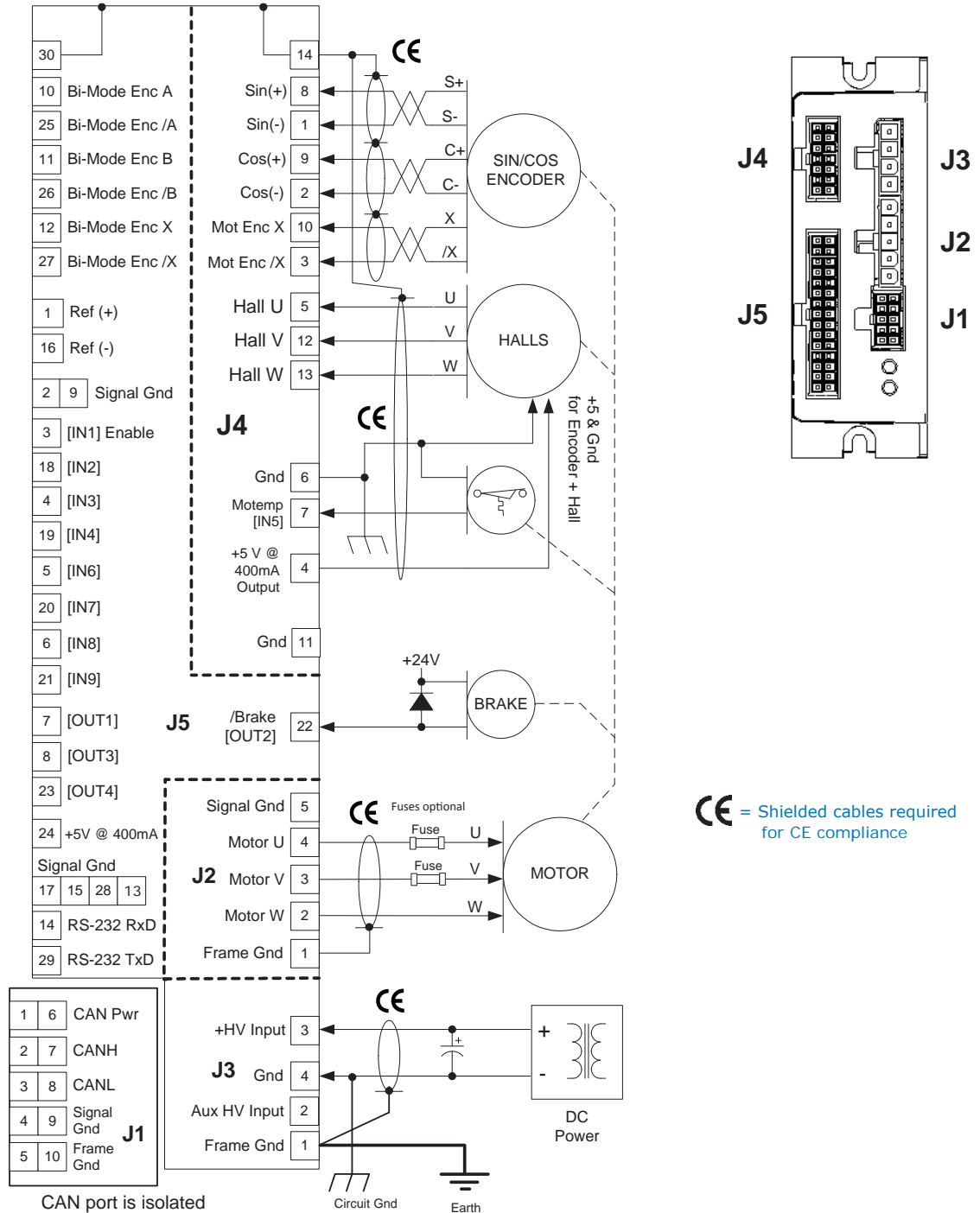

### NOTES

- The functions of input signals on J4-7 and J5-3,4,5,6,18,19,20, and 21 are programmable.
- The function of [IN1] on J5-3 is always Drive Enable and is not programmable. The active level of [IN1] is programmable, and resetting the drive with changes on the enable input is programmable.
- Pins J4-4 and J5-24 connect to the same +5 Vdc @ 400 mAdc power source. Total current drawn from both pins cannot exceed 400 mAdc.
- Pins 5 & 10 of CAN port on J1 connect to frame ground for cable shield. All other CAN port pins are isolated from drive circuits.



## CONNECTORS & SIGNALS

Conductor ratings for contacts (when used with crimping tools shown below):  
 Samtec CC79L-2024-01-F: AWG 24~20 wire, insulation diameter .035" (0.89mm) - .070" (1.78mm)  
 Molex 39-00-0039: AWG 24~18 wire, insulation diameter .051" (1.30mm) - .122" (3.10mm)

**J4 Cable Connector:**  
 14-position poke/crimp  
 Housing: Samtec IPD1-07-D  
 Contacts(14): Samtec CC79L-2024-01-F  
 Crimping tool: Samtec CAT-HT-179-2024-11  
 Contact Extractor: Samtec CAT-EX-179-01

**J3 Cable Connector:**  
 4-position poke/crimp  
 Housing: Molex 39-01-4041  
 Contacts: Molex 39-00-0039  
 Crimping Tool: Molex 11-01-0197  
 Extractor Tool: Molex 11-03-0044

J4 Feedback			
Signal	Pin	Pin	Signal
Sin(+) Input S3	8	1	Sin(-) Input S1
Cos(+) Input S2	9	2	Cos(-) Input S4
Ref(+) Output R1	10	3	Ref(-) Output R2
Signal Ground	11	4	Encoder +5 Vdc
Hall V	12	5	Hall U
Hall W	13	6	Signal Ground
Frame Ground	14	7	Motemp [IN5]

J5 Signal			
Signal	Pin	Pin	Signal
Analog Ref (-)	16	1	Analog Ref (+)
Signal Ground	17	2	Signal Ground
Programmable Input [IN2]	18	3	Enable Input [IN1]
Programmable Input [IN4]	19	4	Programmable Input [IN3]
Programmable Input [IN7]	20	5	Programmable Input [IN6]
Programmable Input [IN9]	21	6	Programmable Input [IN8]
Programmable Output [OUT2]	22	7	Programmable Output [OUT1]
Programmable Output [OUT4]	23	8	Programmable Output [OUT3]
Encoder +5 Vdc	24	9	Signal Ground
Bi-Mode Encoder /A	25	10	Bi-Mode Encoder A
Bi-Mode Encoder /B	26	11	Bi-Mode Encoder B
Bi-Mode Encoder /X	27	12	Bi-Mode Encoder X
Signal Ground	28	13	Signal Ground
RS-232 TxD	29	14	RS-232 RxD
Frame Ground	30	15	Signal Ground

**J5 Cable Connector:**  
 30-position poke/crimp  
 Housing: Samtec IPD1-15-D  
 Contacts(30): Samtec CC79L-2024-01-F  
 Crimping tool: Samtec CAT-HT-179-2024-11  
 Contact Extractor: Samtec CAT-EX-179-01

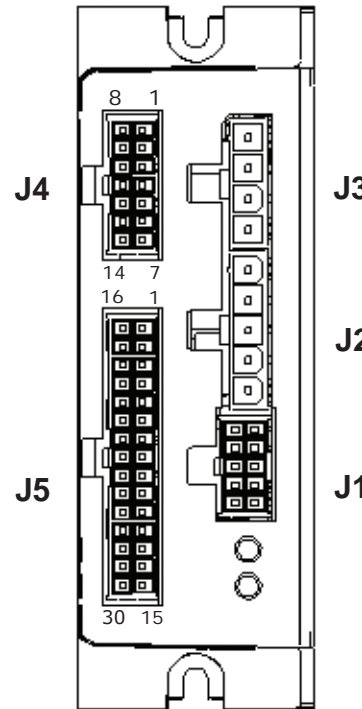

J3 Power	
Pin	Signal
1	Frame Ground
2	Aux HV
3	+HV
4	HV Ground

J2 Motor	
Pin	Signal
1	Frame Ground
2	Motor W
3	Motor V
4	Motor U
5	Signal Ground

**J2 Cable Connector:**  
 5-position poke/crimp  
 Housing: Molex 39-01-4051  
 Contact: Molex 39-00-0039  
 Crimping Tool: Molex 11-01-0197  
 Extractor Tool: Molex 11-03-0044

CAN circuits are isolated from drive circuits

J1 CAN			
Signal	Pin	Pin	Signal
CAN Power	6	1	CAN Power
CANH	7	2	CANH
CANL	8	3	CANL
Signal Ground	9	4	Signal Ground
Frame Ground	10	5	Frame Ground

**J1 Cable Connector:**  
 10-position poke/crimp  
 Housing: Samtec IPD1-05-D  
 Contacts(10): Samtec CC79L-2024-01-F  
 Crimping tool: Samtec CAT-HT-179-2024-11  
 Contact Extractor: Samtec CAT-EX-179-01

## DRIVE CONNECTIONS

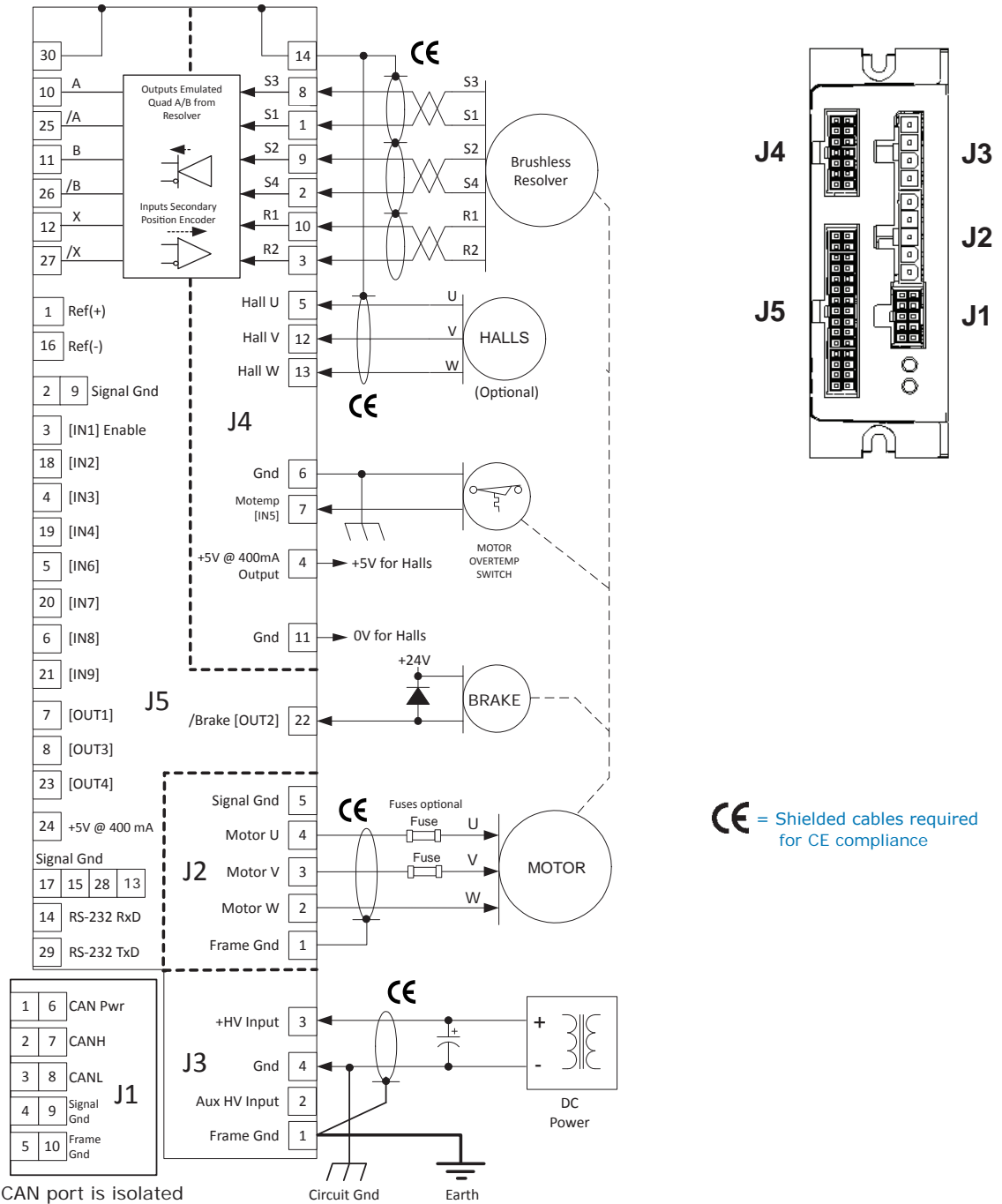

### NOTES

1. The functions of input signals on J4-7 and J5-3,4,5,6,18,19,20, and 21 are programmable.
2. The function of [IN1] on J5-3 is always Drive Enable and is not programmable. The active level of [IN1] is programmable, and resetting the drive with changes on the enable input is programmable.
3. Pins J4-4 and J5-24 connect to the same +5 Vdc @ 400 mAdc power source. Total current drawn from both pins cannot exceed 400 mAdc.
4. Pins 5 & 10 of CAN port on J1 connect to frame ground for cable shield. All other CAN port pins are isolated from drive circuits.

## CABLING FOR COMMUNICATIONS

### RS-232

The Serial Cable Kit (ACJ-SK) is a complete cable assembly that connects a computer serial port (COM1, COM2) to the drive. It is useful for amplifier set up before installation into a system or basic desktop operation. System wiring can be added to the J5 connector leaving the Sub-D connector and cable in place. Or, the J5 plug with system wiring can be removed and the cable-kit J5 plug used which enables operation of the drive while completely isolated from the system.

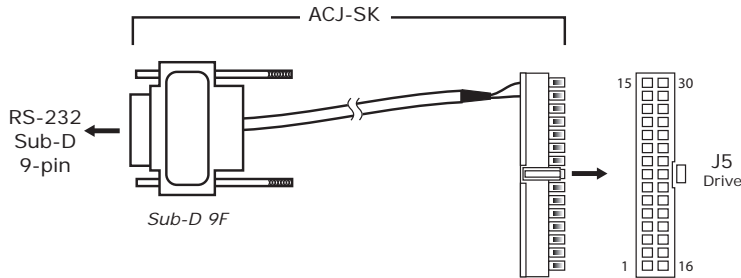

ACJ-SK Connections			
Sub-D 9F	Pin	Pin	Drive J5
RxD	2	29	TxD
TxD	3	14	RxD
Ground	5	15	Ground

*Note: Computers & drives are both DTE devices.  
RxD (Received Data) signals are inputs.  
TxD (Transmitted Data) signals are outputs.*

### CANOPEN

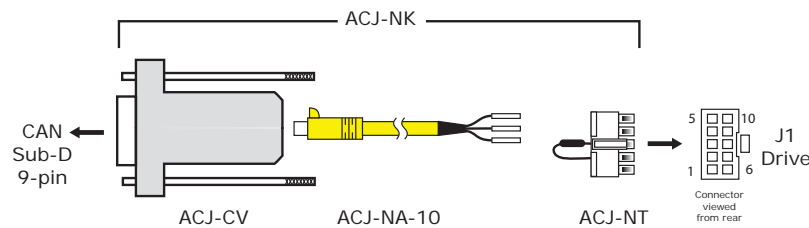

The connector kit for CAN networking (ACJ-NK) provides the parts to connect to a single drive. To use it, the flying leads must be poked into the ACJ-NT (see table for pins). The ACJ-NT comprises the a plug for drive J1 and also a 121 Ω resistor for the CAN bus terminator. The flying leads are left unattached so that the kit can also be used with multiple drives. When this is done, the CAN cables are daisy-chained from drive to drive and the ACJ-NT is only used on the last drive in the chain. The cables used for the daisy-chain are the ACJ-NC-10 or ACJ-NC-01 which have a J1 connector attached to a cable with flying leads and crimps.

ACJ-NK Connections		
Sub-D 9F	Pin	Wire Color
CAN_GND	3	White/Green
CAN_L	2	Orange
CAN_H	7	White/Orange

Note: Sub-D 9F connections comply with CAN CIA DR-303-1

ACJ-NC-01(-10) Connections				
Wire Color	Drive J1 Cable Connector			
	Frame Gnd	5	10	Frame Gnd
White Green	CAN_GND	4	9	CAN_GND
Orange	CAN_L	3	8	CAN_L
White/Orange	CAN_H	2	7	CAN_H
	CAN_V+	1	6	CAN_V+

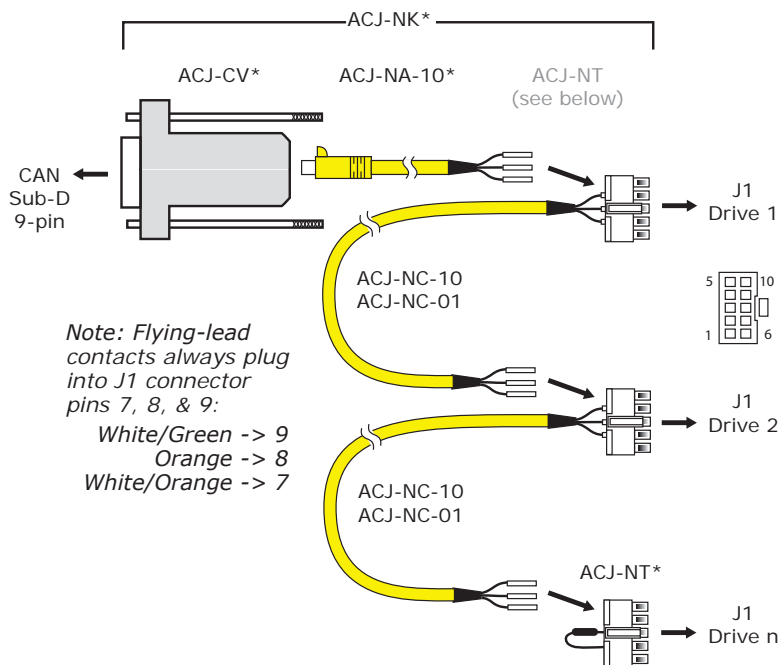

ACJ-NT Connections				
Drive J1 Cable Connector				
Frame Gnd	5	10	Frame Gnd	
CAN_GND	4	9	CAN_GND	
121 Ω Terminator Connects	3	8	CAN_L	
	2	7	CAN_H	
CAN_V+	1	6	CAN_V+	

## CABLING FOR MOTORS

### ACJ-FC-10 FEEDBACK CABLE ASSEMBLY

Color	Pin		Color
Blue	8	1	Black
White	9	2	Black
Orange	10	3	Black
Black	11	4	Red
Brown	12	5	Black
Yellow	13	6	Black
Green	14	7	Black

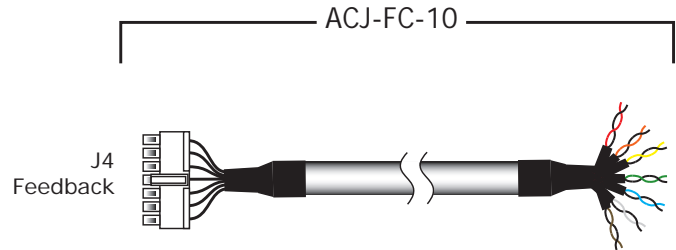

This cable plugs into drive J4 and consists of seven twisted-pairs of AWG 24 wire. Each pair has a black and colored conductor. The chart above shows twisted-pairs in the rows. E.g. one pair goes to pins 1&8, another pair to pins 2&9, etc. Cable termination is flying leads for connection to customer motor feedback encoder.

### ACJ-FC-10 FEEDBACK CABLE QUAD A/B ENCODER CONNECTIONS

Signal	Color	Pin		Color	Signal
Encoder A	Blue	8	1	Black	Encoder /A
Encoder B	White	9	2	Black	Encoder /B
Encoder X	Orange	10	3	Black	Encoder /X
Signal Gnd	Black	11	4	Red	+5 Vdc out
Hall V	Brown	12	5	Black	Hall U
Hall W	Yellow	13	6	Black	Signal Gnd
Frame Gnd	Green	14	7	Black	Motemp [IN5]

### ACJ-FC-10 FEEDBACK CABLE SIN/COS ENCODER CONNECTIONS (-S OPTION)

Signal	Color	Pin		Color	Signal
Sin(+)	Blue	8	1	Black	Sin(-)
Cos(+)	White	9	2	Black	Cos(-)
Encoder X	Orange	10	3	Black	Encoder /X
Signal Gnd	Black	11	4	Red	+5 Vdc out
Hall V	Brown	12	5	Black	Hall U
Hall W	Yellow	13	6	Black	Signal Gnd
Frame Gnd	Green	14	7	Black	Motemp [IN5]

### ACJ-FC-10 FEEDBACK CABLE RESOLVER CONNECTIONS (-R OPTION)

Signal	Color	Pin		Color	Signal
Sin(+) S3	Blue	8	1	Black	Sin(-) S1
Cos(+) S2	White	9	2	Black	Cos(-) S4
Ref(+) R1	Orange	10	3	Black	Ref(-) R2
Signal Gnd	Black	11	4	Red	+5 Vdc out
Hall V	Brown	12	5	Black	Hall U
Hall W	Yellow	13	6	Black	Signal Gnd
Frame Gnd	Green	14	7	Black	Motemp [IN5]

## CABLING FOR COMMUNICATIONS

### MULTI-DROP RS-232

The RS-232 specification does not support multi-drop (multiple device) connections as does RS-485 or CAN. However, it is possible to address multiple CAN-enabled Copley drives from a single RS-232 port. First, an RS-232 connection is made between the computer and drive #1 which must be given a CAN address of 0. Under normal CAN operation, this address is not allowed for CAN nodes. But, in this case, drive #1 will act as a CAN master and so address 0 is allowed. Next, CAN connections are made between drive #1, drive #2, and so on in daisy-chain fashion to the last drive. The last drive in the chain must have the 120 Ω resistor between the CAN\_H and CAN\_L signals to act as a line-terminator. Finally, the CAN addresses of the drives downstream from drive #1 are set to unique numbers, none of which can be 0.

When ASCII data is exchanged over the serial port, the commands are now preceded with the node address of the drive. Drive #1 converts the data into CAN data which is then sent to all of the drives in the chain. It now appears as though all drives in the chain are connected to the single RS-232 port in the computer and for that reason we refer it as *multi-drop* RS-232.

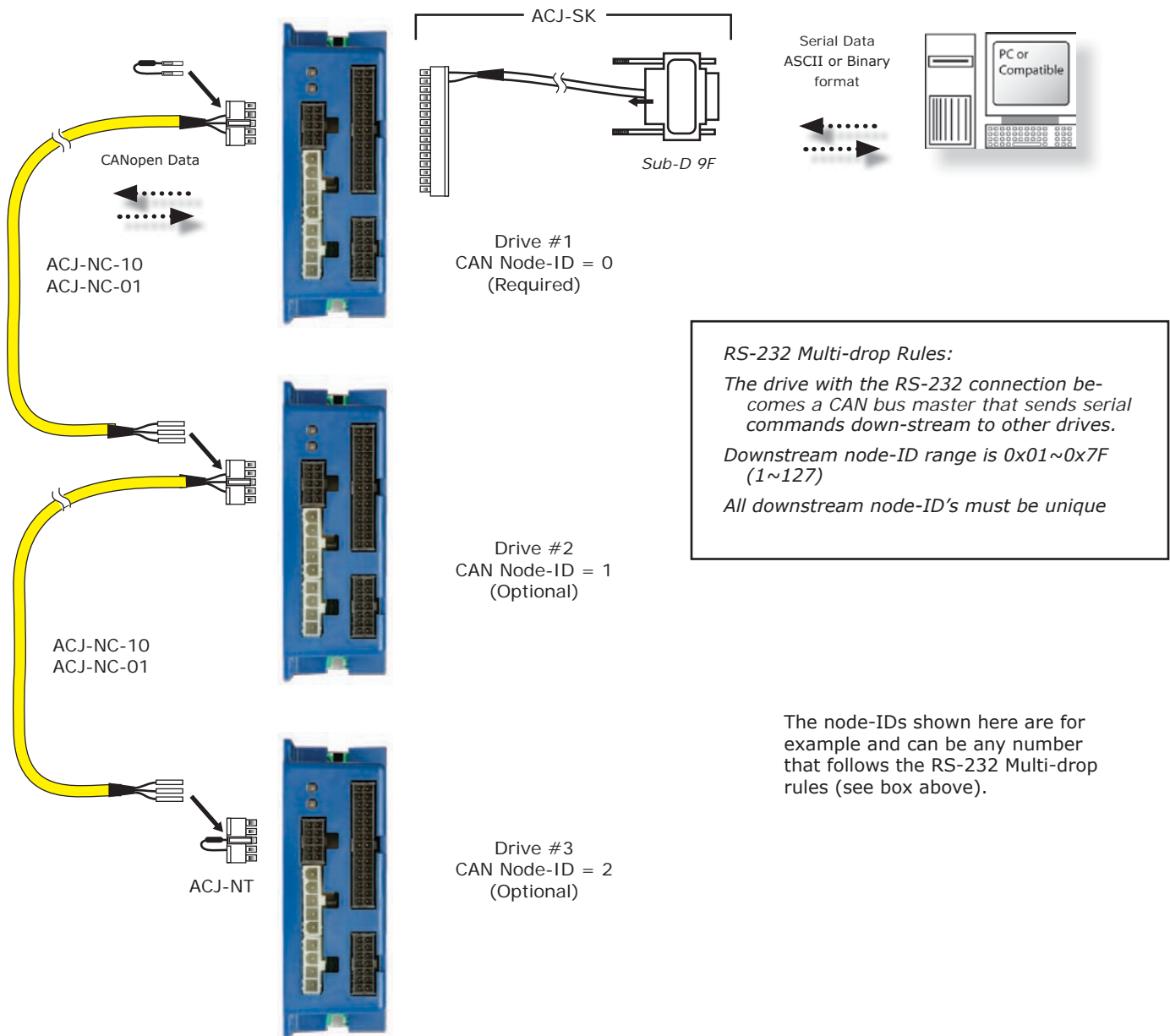

The node-IDs shown here are for example and can be any number that follows the RS-232 Multi-drop rules (see box above).



## SINGLE-DRIVE SETUP FOR CANOPEN POSITION CONTROL

Drive operates as a CAN node. All commands are passed on the CAN bus.  
 CME 2 is used for setup and configuration before installation as CAN node.

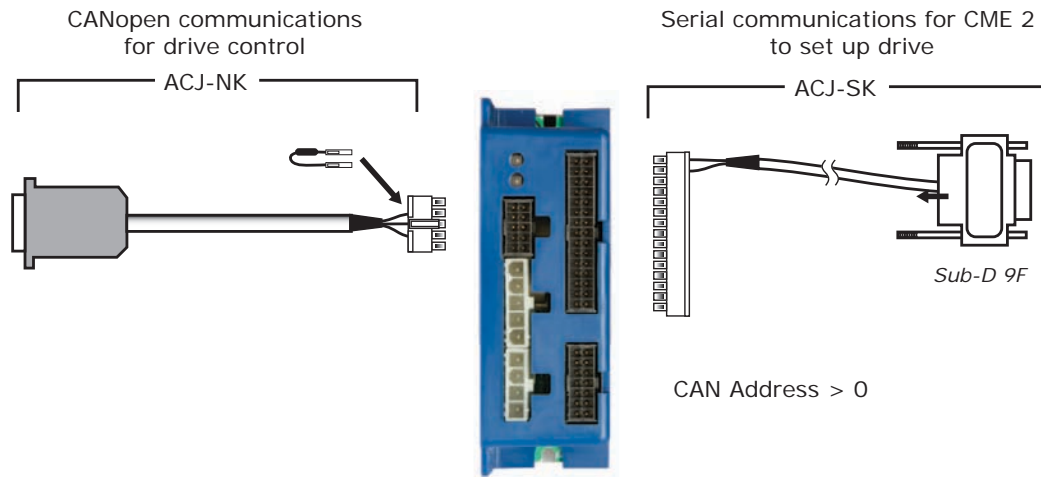

When using CME2, the CAN bus communications should be suspended.

*CANopen Rules:*  
 Node-ID 0 is reserved for bus master  
 Slave node-ID range is 0x01~0x7F (1~127)  
 All slave node-ID's must be unique

## MULTIPLE-DRIVE SETUP FOR CANOPEN CONTROL

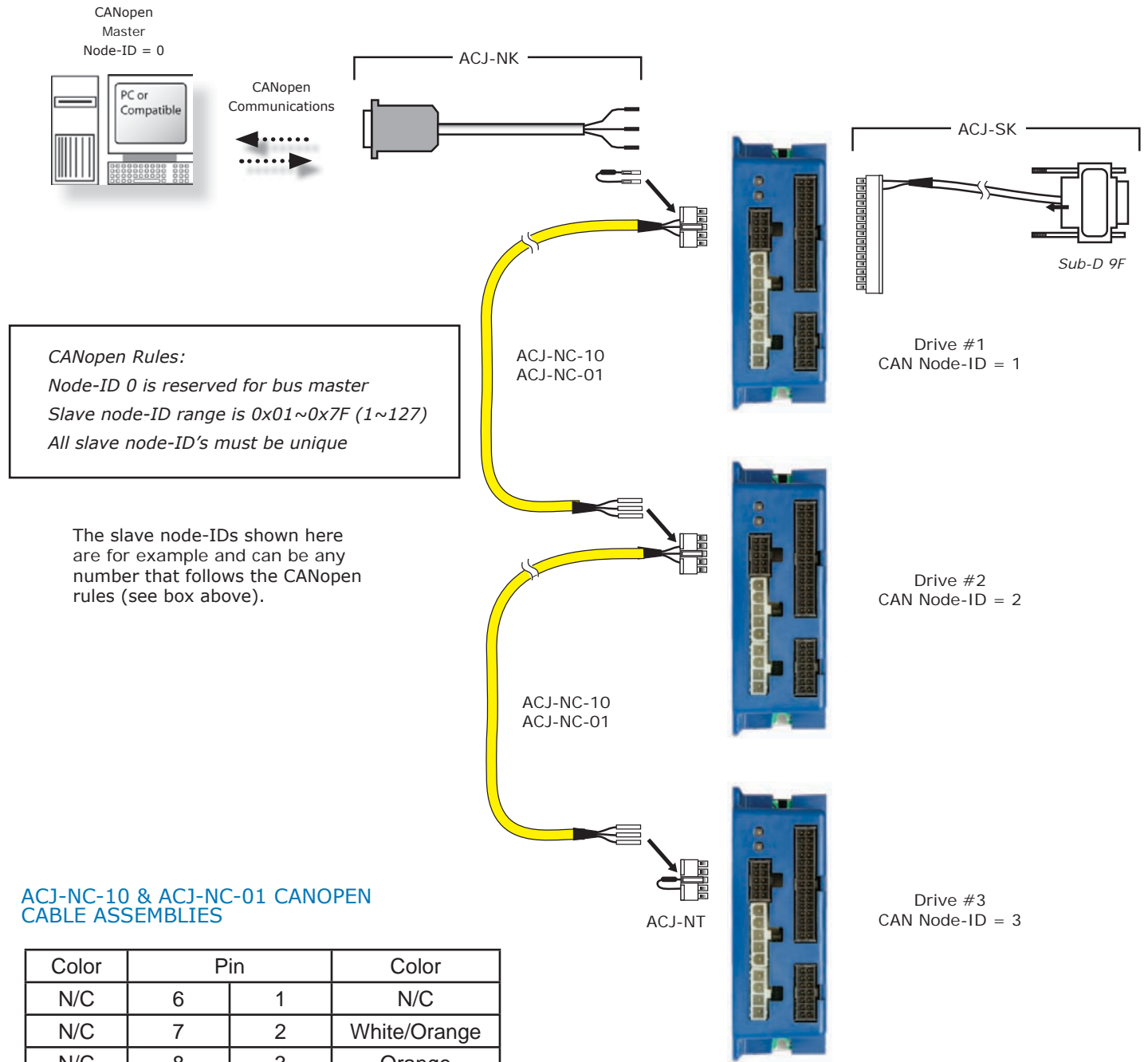

These cables connect to amplifier J1 and have 3 conductors of AWG 24 wire that are terminated in contacts that can then be inserted into pins 7~9 of another ACJ-NC-10 to "daisy chain" the CAN signals to multiple amplifiers.

## STAND-ALONE OPERATION

Drive takes digital position commands in Pulse/Direction, or CW/CCW format from an external controller or quadrature encoder signals from a master-encoder for electronic gearing. Velocity or torque control can be from  $\pm 10V$ , digital PWM signals.

*CME 2* used for setup and configuration.

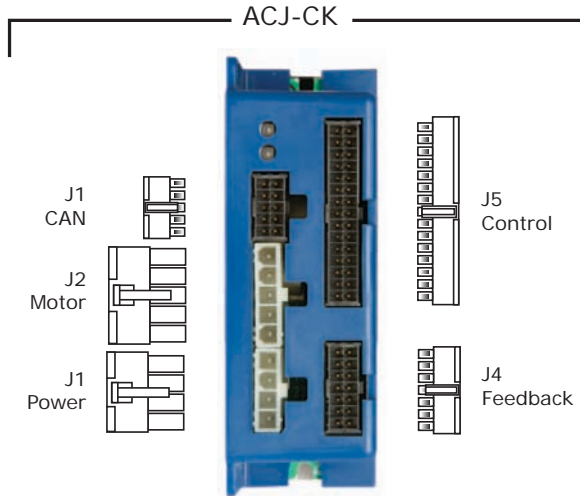

**Notes:**

1. Kit contains connector shells and crimp-contacts for J1 – J5.
2. Crimp-contacts are not shown

## ORDERING GUIDE

This table shows parts to order for the configuration on this page  
 See page 21 for other parts required (motor, +24 Vdc power supply, etc.)

MODEL		DESCRIPTION
ACJ-055-09	ACJ-055-09-S	ACJ Drive 3/9 A, 55 Vdc
ACJ-055-18	ACJ-055-18-S	ACJ Drive 6/18 A, 55 Vdc
ACJ-090-03	ACJ-090-03-S	ACJ Drive 1/3 A, 90 Vdc
ACJ-090-09	ACJ-090-09-S	ACJ Drive 3/9 A, 90 Vdc
ACJ-090-12	ACJ-090-12-S	ACJ Drive 6/12 A, 90 Vdc
ACJ-CK		Connector Kit
ACJ-SK		Serial Cable Kit

## MOUNTING AND COOLING: CONTINUOUS OUTPUT CURRENT VS. MOUNTING AND AMBIENT TEMPERATURE

### VERTICAL MOUNTING ON INFINITE HEATSINK

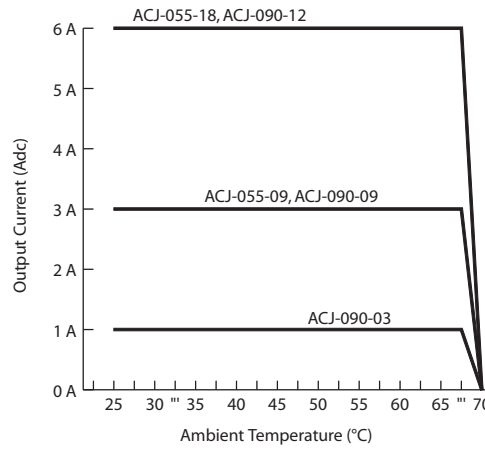
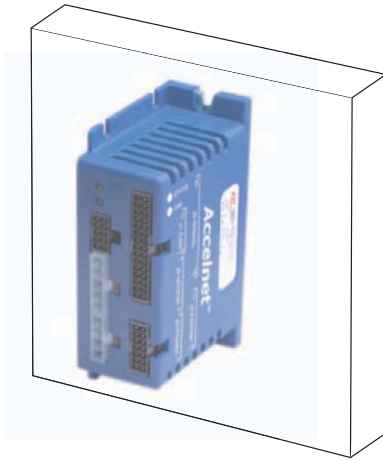

### HORIZONTAL MOUNTING, FAN-COOLED, 400 LFM

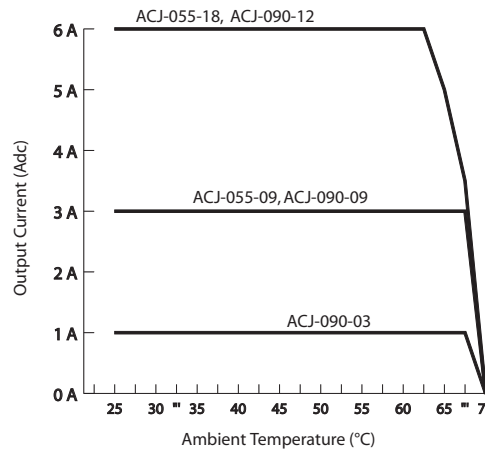
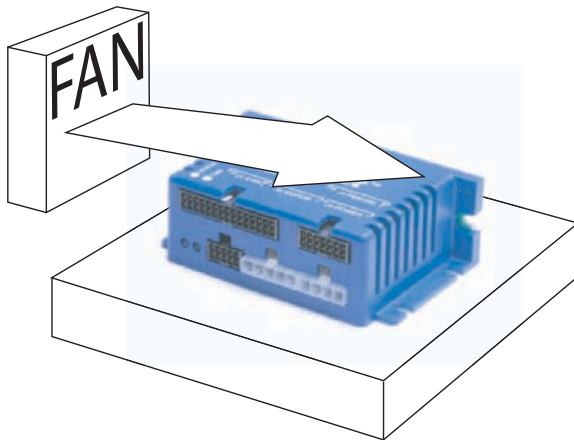

### HORIZONTAL MOUNTING, CONVECTION COOLING

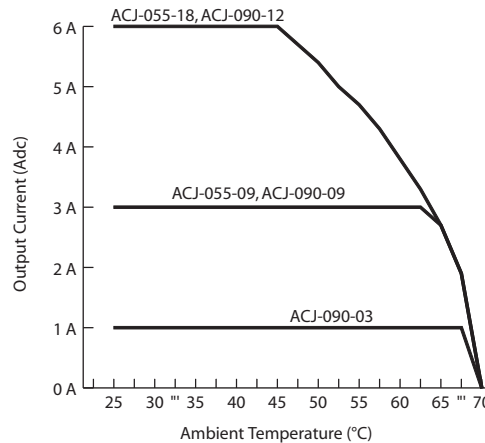
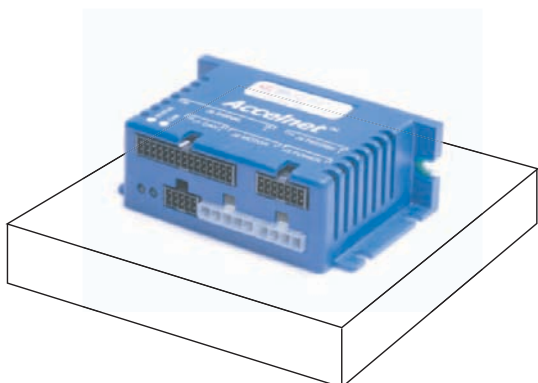

## DIMENSIONS

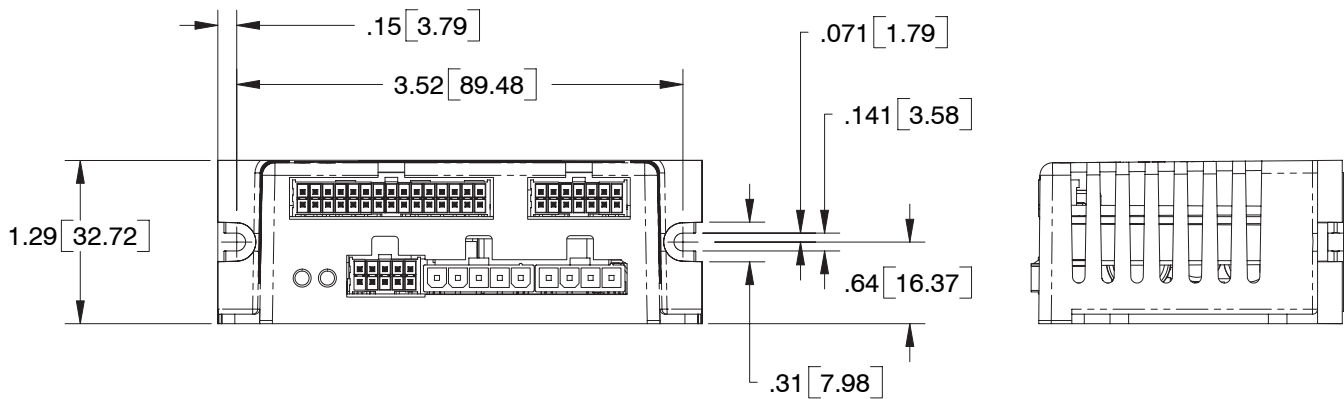
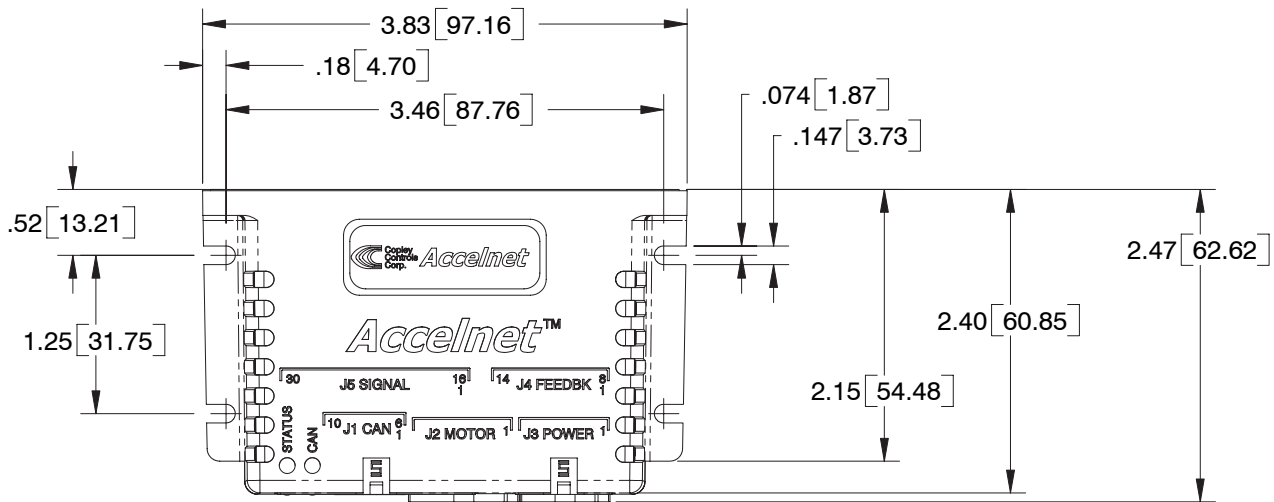

### Notes

1. Dimensions shown in inches[mm].
2. Weight: 4.8 oz (0.14 kg)
3. Recommended mounting hardware is pan-head SEMS screws with internal tooth lock washers, imperial size #4-40 or metric M3 thread.
4. For CE compliance heatplate must be grounded. When mounted with heatplate against the panel, the screws will ground the heatplate to the panel. If mounted with the plastic base against the panel, then a wire must be used to ground the heatplate. If this is terminated in a ring-lug, then this can be attached to the heatplate with a screw and nut of the size recommended above.



## MASTER ORDERING GUIDE

### DRIVES

QUAD A/B MODELS	SIN/COS MODELS	DESCRIPTION
ACJ-055-09	ACJ-055-09-S	Accelnet Micro Panel Servodrive 3/9 Adc @ 55 Vdc
ACJ-055-18	ACJ-055-18-S	Accelnet Micro Panel Servodrive 6/18 Adc @ 55 Vdc
ACJ-090-03	ACJ-090-03-S	Accelnet Micro Panel Servodrive 1/3 Adc @ 90 Vdc
ACJ-090-09	ACJ-090-09-S	Accelnet Micro Panel Servodrive 3/9 Adc @ 90 Vdc
ACJ-090-12	ACJ-090-12-S	Accelnet Micro Panel Servodrive 6/12 Adc @ 90 Vdc

### ACCESSORIES

ORDER NUMBER	Qty	Ref	DESCRIPTION
ACJ-CK Connector kit with poke/crimp connectors (includes next 7 items shown below)			
	1	J1	Connector housing, CAN, 10 position (Samtec)
	1	J2	Connector housing, motor, 5 position (Molex Mini-Fit)
	1	J3	Connector housing, power, 4 position (Molex Mini-Fit)
	1	J4	Connector housing, feedback, 14 position (Samtec)
	1	J5	Connector housing, control, 30 position (Samtec)
	60	J1,J4,J5	Contact, crimp, female, for AWG 24~20 wire (Samtec)
	12	J2,J3	Contact, crimp, female, for AWG 24~20 wire (Molex Mini-Fit)
ACJ-NK Connector kit for CANOpen networking (includes next 3 items shown below)			
ACJ-CV	1	J1	Cable adapter: Sub-D 9 position female to RJ-45 female
ACJ-NA-10	1	J1	CANOpen cable assembly: RJ-45 plug to flying leads with crimps, 10 ft (3 m)
ACJ-NT	1	J1	CANOpen terminator (J1 plug with resistor)
Individual Components			
ACJ-CV		J1	Cable adapter: Sub-D 9 position female to RJ-45 female
ACJ-FC-10		J4	Feedback cable assembly, 10 ft (3 m), with flying leads
ACJ-NA-10		J1	CANOpen cable assembly: RJ-45 plug to flying leads with crimps, 10 ft (3 m)
ACJ-NC-10		J1	CANOpen cable assembly: drive J1 plug to flying leads with crimps , 10 ft (3 m)
ACJ-NC-01		J1	CANOpen cable assembly: drive J1 plug to flying leads with crimps , 1 ft (0.3 m)
ACJ-NT		J1	CANOpen network terminator (J1 plug with resistor)
ACJ-SK		J5	Serial cable kit: Sub-D 9 position female to drive J5 connector, 6 ft (1.8 m)
CME2			CME 2™ CD (CME 2)

#### ORDER EXAMPLE: STAND-ALONE, SIN/COS

Qty	Order No.	Description
1	ACJ-090-09-S	Accelnet Micro Panel
1	ACJ-CK	Connector Kit
1	ACJ-FC-10	Feedback Cable, 10 ft (3m)
1	ACJ-SK	Serial Cable Kit
1	CME2	CME 2 Program CD

#### ORDER EXAMPLE: CAN NETWORKING, QUAD A/B

Qty	Order No.	Description
1	ACJ-090-09	Accelnet Micro Panel
1	ACJ-CK	Connector Kit
1	ACJ-NK	Network Connector Kit
1	ACJ-SK	Serial Cable Kit
1	CME2	CME 2 Program CD
For each additional ACJ drive in a CAN network:		
1	ACJ-NC-10	Drive J1 plug to flying leads, 10 ft (3 m)
	or	
1	ACJ-NC-01	Drive J1 plug to flying leads, 1 ft (0.3 m)

### ROHS COMPLIANCE



Models with the green leaf symbol on the label are RoHS compliant.

Note: Specifications subject to change without notice

Rev 9.01\_tu 11/29/2011