

RUGGEDIZED TRAPEZOIDAL TORQUE AMPLIFIER FOR BRUSHLESS/BRUSH MOTORS

ANALOG INPUTS

- ± 10 Vdc current reference
- Peak, continuous current & peak-time set

ANALOG OUTPUTS

- Current monitor
- Current reference

DIGITAL INPUTS

- Amp Enable
- Fwd/Rev Enable (limit switches)
- Hi/Lo load inductance

DIGITAL OUTPUTS

- Amp OK
- Regen control
- Brake control

FEEDBACK

- Digital Halls from brushless motors

DIMENSIONS

- 53.3 x 45.7 x 15.2 mm
- 2.1 x 1.8 x 0.6 in

DESCRIPTION

R30 is a compact, DC powered analog current amplifier for torque control of DC brush or brushless motors. It operates as a stand-alone driver taking a ± 10 V input from an external controller. Mounting to a PC board with solderless connectors facilitates low-cost, multi-axis designs.

The Amp Enable input interfaces to active LO signals up to 24 Vdc. Another digital input switches the current-loop gain from a high to low for load inductance compensation. Forward and Reverse Enable inputs are provided for limit switches.

A digital output for Amp-OK indicates the amplifier's status. There are two other digital outputs one of which can activate an external regenerative energy dissipator circuit and another for motor brake control.

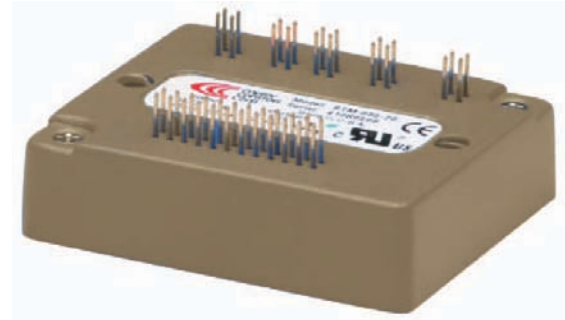

Actual Size

| Model | Vdc | Ic | Ip |
|------------|-------|----|----|
| R30-055-20 | 12~55 | 10 | 20 |
| R30-090-10 | 20~90 | 5 | 10 |

Digital Hall feedback enables trapezoidal drive of DC brushless motors. For driving DC brush motors, these inputs are left unconnected and the motor connected between the U & V outputs.

Protections include I2T current limiting for peak and continuous current as well as peak time. Short circuits between outputs or to ground and amplifier over-temperature produce latching faults.

RUGGEDIZED STANDARDS CONFORMANCE

| | | |
|------------------------|---------------|---------------------------------|
| Ambient Temperature | Non-Operating | -50°C to 85°C |
| | Operating | -40°C to 70°C |
| Thermal Shock | Operating | -40°C to 70°C in 1 minute |
| Relative Humidity | Non-Operating | 95% non-condensing at 60°C |
| | Operating | 95% non-condensing at 60°C |
| Vibration | Operating | 5 Hz to 500 Hz, up to 3.85 grms |
| Altitude | Non-Operating | -400 m to 12,200 m |
| | Operating | -400 m to 5,000 m |
| Shock | Crash Safety | 75 g peak acceleration |
| | Operating | 40 g peak acceleration |
| MIL-STD specifications | MIL-STD- | 461, 704, 810, 1275, 1399 |
| IEC specifications | IEC- | 60068, 60079 |

DEVELOPMENT KIT

A Development Kit is available that provides mounting and easy connectivity for the R30.

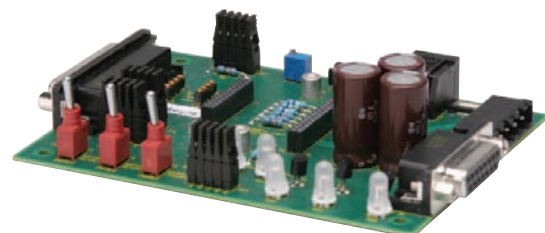

GENERAL SPECIFICATIONS

Test conditions: Load = Wye connected load: 2 mH + 2 Ω line-line. Ambient temperature = 25°C, +HV = HV_{max}

| MODEL | R30-055-20 | R30-090-10 | |
|--|--|------------|---------------------------|
| OUTPUT POWER | | | |
| Peak Current | 20 | 10 | Adc, ±5% |
| Peak time | 1 | 1 | Sec |
| Continuous current | 10 | 5 | Adc, ±5% |
| Peak Output Power | 1045 | 855 | W |
| Continuous Output Power | 523 | 427 | W |
| Output resistance | 0.075 | 0.075 | Rout (Ω) |
| Maximum Output Voltage | Vout = HV*0.97 - Rout*Iout | | |
| INPUT POWER | | | |
| HV _{min} to HV _{max} | +12 to +55 | +20 to +90 | Vdc, Transformer-isolated |
| Ipeak | 20 | 10 | Adc (1 sec) peak |
| Icont | 10 | 5 | Adc continuous (Note 1) |
| PWM OUTPUTS | | | |
| Type | 3-phase MOSFET, 33 kHz | | |
| Commutation | Trapezoidal using digital Hall feedback | | |
| CONTROL | | | |
| Analog Reference Input | ±10 Vdc, 100 kΩ differential input impedance | | |
| Bandwidths | Current loop: 2.5 kHz typical, bandwidth will vary with tuning & load inductance | | |
| Minimum load inductance | 200 μH line-line | | |
| FEEDBACK | | | |
| Digital Halls | 3, non-isolated, for brushless motor commutation 10 kΩ to +5 Vdc pull-up with 33 μs RC filter to 74HC14 Schmitt trigger | | |
| Power | +5 Vdc @ 250 mA max. (J1-21, 22) to power Hall sensors or commutating encoder | | |
| DIGITAL INPUTS | | | |
| Number | 4 | | |
| [IN1] /Enable | Amplifier enable, LO active, HI disables | | |
| /PosEnab, /NegEnab | Forward and reverse direction limit switch/enable inputs: HI will disable output current in direction | | |
| Type | 74HC14 Schmitt trigger operating from +5 Vdc with RC filter on input Vin-LO < 1.35 Vdc, Vin-HI > 3.65 Vdc, input voltage range 0 to +24 Vdc 10 kΩ to +5 Vdc pull-up, 74HC14 Schmitt trigger operating from +5 Vdc with RC filter on input 74HCT, Vil = 0.8 Vdc max, Vih = 2.0 Vdc min, input voltage range 0 to +24 Vdc | | |
| [LoInd] Low Inductance | HI or open: for higher inductance loads, LO or grounded: for lower inductance loads | | |
| ANALOG INPUTS | | | |
| Number | 5 | | |
| Ref(+), Ref(-) | Command input for output current demand, ±10 Vdc | | |
| Peak Current Limit | 0.5 to 4.80 Vdc sets peak current limit from 10~100% of rated peak current | | |
| Continuous Current Limit | 0.5 to 4.87 Vdc sets continuous current limit from 10~100% of rated continuous current | | |
| I2T Limit | 0.5 to 5.00 Vdc sets 10~100% of I2T time | | |
| Balance | ±2.5 Vdc from the 2.5 Vdc quiescent state will adjust output current ±1% of peak rated current | | |
| DIGITAL OUTPUTS | | | |
| Number: type | 3: N-channel MOSFET, open-drain, 30 Vdc max, 100 mA max for [AOK] and [OUT1], 1000 mA for [OUT2] | | |
| [AOK] | Amp OK: active LO when amplifier has no faults and will operate when enabled | | |
| [OUT1] | Configured as external regen switch controller: will be LO to turn on regen switch | | |
| [OUT2] | Brake control (external flyback diode required): will be LO when AOK and is enabled to release brake | | |
| ANALOG OUTPUT | | | |
| Current Monitor | ±3.0 Vdc @ ±Ipeak | | |
| Current Ref | Monitor for current-loop command: ±3.0 Vdc = ±100% of rated peak current | | |

NOTES

1) Heatsink is required for continuous current rating.

MOTOR CONNECTIONS

| | |
|---------------|---|
| Phase U, V, W | PWM outputs to 3-phase ungrounded Wye or delta wound brushless motors, or DC brush motors (U-V) |
| Hall U, V, W | Digital Hall signals, single-ended |
| Hall power | +5 Vdc $\pm 2\%$ @ 250 mAdc max |

PROTECTIONS

| | |
|-----------------------------------|--|
| HV Overvoltage | +HV > HV _{max} , Amplifier outputs turn off until +HV < HV _{max} (See Input Power for HV) |
| HV Undervoltage | R30-090-10: +HV < +20 Vdc, Amplifier outputs turn off until +HV > +20 Vdc R30-055-20: +HV < +12 Vdc, Amplifier outputs turn off until +HV > +12 Vdc |
| Amplifier over temperature | Heat plate > 80°C |
| Short circuits | Output to output, output to ground, internal PWM bridge faults |
| I ² T Current limiting | Programmable: continuous current, peak current, peak time |

MECHANICAL & ENVIRONMENTAL

| | |
|--------------|--|
| Size | 2.1 x 1.8 x 0.6 [53.3 x 45.7 x 15.2] in [mm] |
| Weight | |
| Contaminants | Pollution degree 2 |
| Environment | IEC68-2: 1990 |
| Cooling | Conduction through heatplate on amplifier chassis, or convection |

AMPLIFIER DIMENSIONS

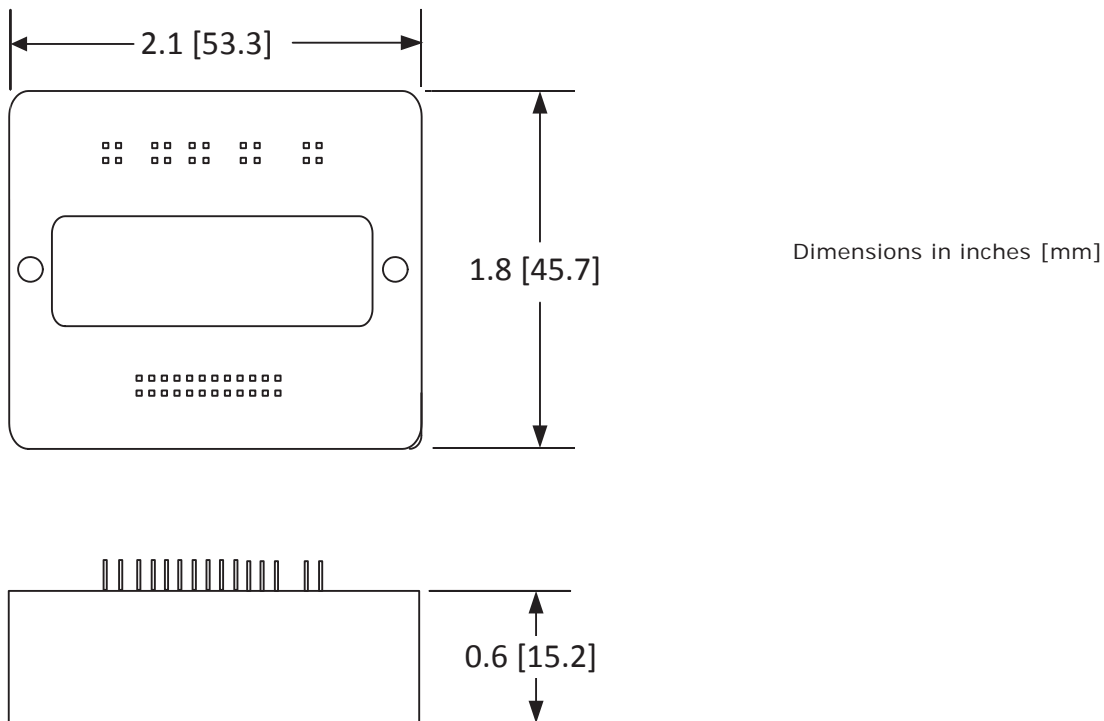

CONTROL INPUTS AND OUTPUTS

ENABLE INPUT

The Enable input [IN1] is LO-active and pulled up to +5V by an internal 10k resistor. This provides fail-safe operation by disabling the amplifier if the Enable input is open, or a wire from the controller should break.

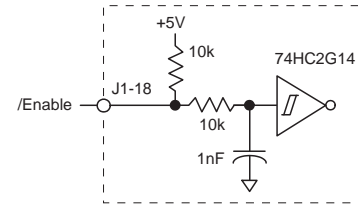

FWD/REV ENABLE INPUTS

Two inputs are provided for limit switches. These should be LO for normal operation, and open or HI to inhibit current of positive or negative polarity.

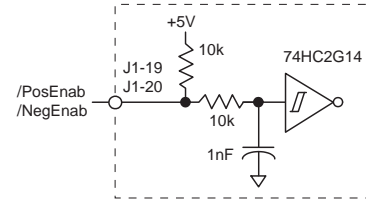

LOAD INDUCTANCE INPUT

The /LowInd input controls the gain of the current error amplifier to compensate the amplifier for lower or higher inductance loads. With the input open, the bandwidth will be ~2.5 kHz for a 2 mH (line-line) load. Grounding the input reduces the gain to 1/10 of the input-open gain for the same bandwidth with 200 μH loads.

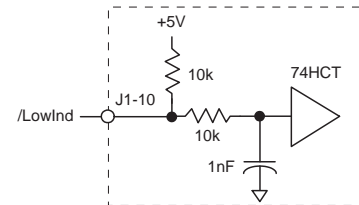

ANALOG REFERENCE INPUT

The amplitude and polarity of the amplifier output current is controlled by a ±10V analog signal from an external controller.

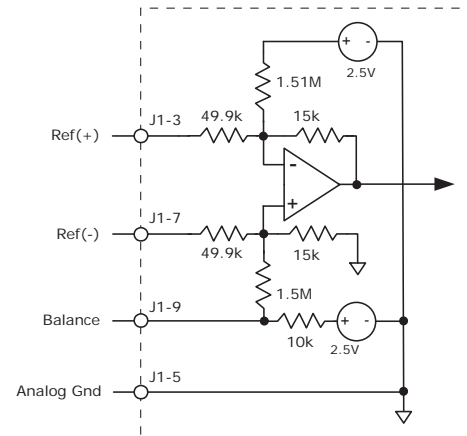

BALANCE INPUT

The output current of the amplifier can be adjusted to 0 Adc by connecting the balance input to a potentiometer with an adjustment range of 0 to +5 Vdc. This will produce an offset adjustment range of ±0.8% of the Ipeak rating of the amplifier. The table below shows the offset adjustment range in mA.

| MODEL | ±IOFFSET (MA) |
|------------|---------------|
| R30-055-20 | 160 |
| R30-090-10 | 80 |

DIGITAL OUTPUTS

Three N-channel MOSFETs sink current from loads connecting to +30 Vdc maximum. Outputs [AOK] and [OUT1] can sink 100 mA maximum. The brake output [OUT2] can sink 1000 mA. An external flyback diode is required with driving inductive loads like a brake, or relays.

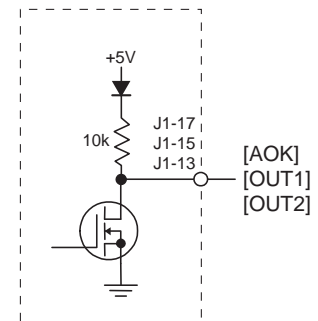

MOTOR CONNECTIONS

Motor connections are of two types for brushless motors: phases and Halls. For brush motors, only the armature connections are needed. The phase or armature connections carry the amplifier output currents that drive the motor to produce motion. The Hall signals are three digital signals used for commutating a brushless motor. When using a brush motor the Hall inputs should be unconnected and the motor armature connections made between the U & V phase outputs.

MOTOR PHASE CONNECTIONS: BRUSHLESS

The amplifier output is a three-phase PWM inverter that converts the DC buss voltage (+HV) into DC voltage waveforms that drive two motor phase-coils at a time (trapezoidal commutation). Cable should be sized for the continuous current rating of the amplifier. Motor cabling should use twisted, shielded conductors for CE compliance, and to minimize PWM noise coupling into other circuits. The motor cable shield should connect to motor frame and the equipment frame ground for best results.

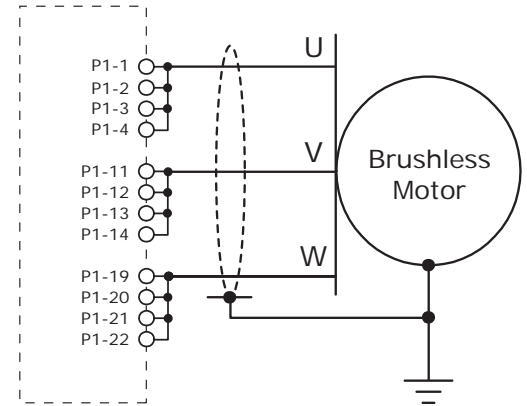

MOTOR PHASE CONNECTIONS: BRUSH

The amplifier output is an H-bridge PWM inverter that converts the DC bus voltage (+HV) into a DC voltage waveform that drives the motor armature. Cable should be sized for the continuous current rating of the amplifier. Motor cabling should use twisted, shielded conductors for CE compliance, and to minimize PWM noise coupling into other circuits. The motor cable shield should connect to motor frame and the equipment frame ground for best results.

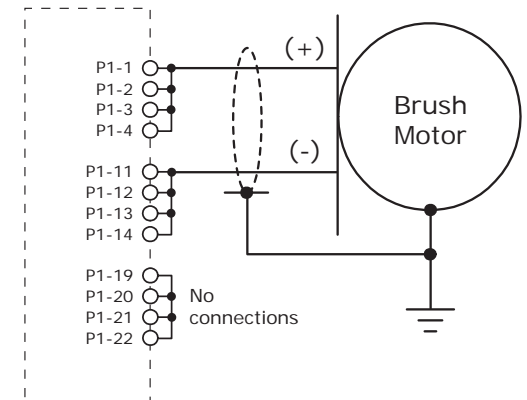

MOTOR HALL SIGNALS

Hall signals are single-ended signals that provide absolute feedback within one electrical cycle of the motor. There are three of them (U, V, & W) and they may be sourced by magnetic sensors in the motor, or by encoders that have Hall tracks as part of the encoder disc. They typically operate at much lower frequencies than the motor encoder signals, and are used for commutation. When driving DC brush motors, the Hall inputs should be left unconnected.

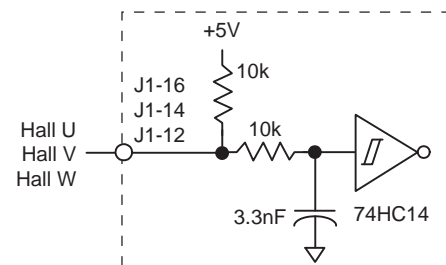

CURRENT LIMIT INPUTS

Two inputs are provided for setting the peak and continuous current limits. The I-Peak and I-Cont inputs each have equivalent circuits shown below. Limits can be set either by applying a voltage (Vset) to the input or by connecting a resistor (Rset) between input and signal ground. The tables below show values for Rset and Vset that give 10~100% of the rated peak and continuous current ratings.

AMPLIFIER MODELS AND RATINGS

| Model | I-Peak | I-Cont | T-Peak | I2T |
|------------|--------|--------|--------|-----|
| R30-055-20 | 20 | 10 | 1 | 400 |
| R30-090-10 | 10 | 5 | | 100 |

PEAK CURRENT LIMIT SETTINGS

| % | Vpeak | Rpeak |
|-----|-------|-------|
| 100 | 4.80 | <OUT> |
| 90 | 4.32 | 86400 |
| 80 | 3.84 | 38400 |
| 70 | 3.36 | 22400 |
| 60 | 2.88 | 14400 |
| 50 | 2.4 | 9600 |
| 40 | 1.92 | 6400 |
| 30 | 1.44 | 4114 |
| 20 | 0.96 | 2400 |
| 10 | 0.48 | 1067 |

EQUIVALENT CIRCUIT

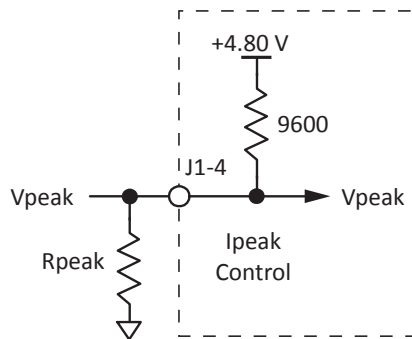

EXAMPLE I-Peak SETTING

If a voltage Vpeak is used to control the peak-limit current, it can be found like this:

$$V_{peak} = \frac{4.80 * PeakLimitCurrent}{AmpPeakCurrent}$$

Example: find Vpeak for a 6 A PeakLimitCurrent using a R30-090-20:

$$V_{peak} = \frac{4.80 * 6}{20} = 1.44 \text{ V}$$

To use a resistor for setting Peak-Limit current, calculate the value as follows:

$$R_{peak} = \frac{9600 * PeakLimitCurrent}{(AmpPeakCurrent - PeakLimitCurrent)}$$

Example: find Rpeak for a 14 A PeakLimitCurrent:

$$R_{peak} = \frac{9600 * 14}{(20 - 14)} = 22,400 \text{ ohms}$$

To use the table, find the % value as follows:

$$\% = \frac{PeakLimitCurrent * 100}{AmpPeak \text{ Current}}$$

CONTINUOUS CURRENT LIMIT SETTINGS

| % | Vcont | Rcont |
|-----|-------|-------|
| 100 | 4.87 | <OUT> |
| 90 | 4.38 | 88189 |
| 80 | 3.90 | 39195 |
| 70 | 3.41 | 22864 |
| 60 | 2.92 | 14698 |
| 50 | 2.44 | 9799 |
| 40 | 1.95 | 6533 |
| 30 | 1.46 | 4199 |
| 20 | 0.97 | 2450 |
| 10 | 0.49 | 1089 |

EQUIVALENT CIRCUIT

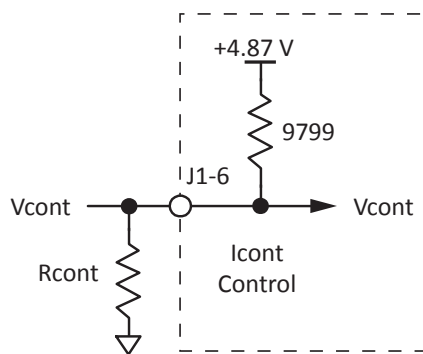

EXAMPLE Icont SETTING

If a voltage Vcont is used to control the peak-limit current, it can be found like this:

$$V_{cont} = \frac{4.80 * ContLimitCurrent}{AmpContCurrent}$$

Example: find Vcont for a 3 A ContLimitCurrent using a R30-090-10:

$$V_{cont} = \frac{4.87 * 3}{5} = 2.92 \text{ V}$$

To use a resistor for setting Cont-Limit current, calculate the value as follows:

$$R_{cont} = \frac{9799 * ContLimitCurrent}{(AmpContCurrent - ContLimitCurrent)}$$

Example: find Rcont for a 2 A ContLimitCurrent:

$$R_{cont} = \frac{9799 * 2}{(5 - 2)} = 6,533 \text{ ohms}$$

To use the table, find the % value as follows:

$$\% = \frac{ContLimitCurrent * 100}{AmpContCurrent}$$

PWM LIMITING INPUT

I2T LIMIT SETTINGS

| % | Vi2t | Ri2t |
|-----|------|-------|
| 100 | 5.0 | <OUT> |
| 90 | 4.50 | 90000 |
| 80 | 4.00 | 40000 |
| 70 | 3.50 | 23333 |
| 60 | 3.00 | 15000 |
| 50 | 2.50 | 10000 |
| 40 | 2.00 | 6667 |
| 30 | 1.50 | 4286 |
| 20 | 1.00 | 2500 |
| 10 | 0.50 | 1111 |

EQUIVALENT CIRCUIT

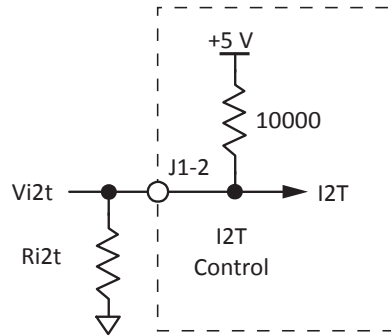

EXAMPLE I2T SETTING

If a voltage V_{peak} is used to control the I2T, it can be found like this:

$$Vi2t = \frac{5.0 * I2TSecs}{AmpI2TLimit}$$

Example: find $Vi2t$ for a 6 A PeakLimitCurrent using a R30-090-20:

$$V_{peak} = \frac{4.80 * 6}{20} = 1.44 \text{ V}$$

To use a resistor for setting Peak-Limit current, calculate the value as follows:

$$R_{peak} = \frac{9600 * PeakLimitCurrent}{(AmpPeakCurrent - PeakLimitCurrent)}$$

Example: find R_{peak} for a 14 A PeakLimitCurrent:

$$R_{peak} = \frac{9600 * 14}{(20 - 14)} = 22,400 \text{ ohms}$$

ABOUT PWM LIMITING

PWM limiting sets a maximum value for the on vs. off time of the outputs of the amplifier. While the peak voltage seen by the load remains about the same as the supply voltage (HV), the average voltage seen by the motor can be limited. A common use of this is to limit the maximum RPM of a motor even though it's operating in torque mode.

PWM LIMIT SETTINGS

| % | Rset (K) | Vset |
|----|----------|------|
| 97 | <OUT> | 4.95 |
| 78 | 42 | 4.00 |
| 70 | 30 | 3.71 |
| 68 | 25 | 3.54 |
| 62 | 20 | 3.3 |
| 57 | 15 | 2.97 |
| 45 | 10 | 2.48 |
| 38 | 7.5 | 2.12 |
| 28 | 5 | 1.65 |
| 25 | 2.5 | 0.99 |
| 25 | 0 | 0 |

EQUIVALENT CIRCUIT

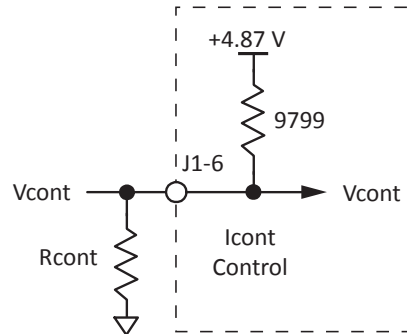

EXAMPLE PWM SETTING

The table shows duty cycles measured with some choices of Rset for the PWM limits.

PC BOARD DESIGN

Printed circuit board layouts for R30 amplifiers should follow some simple rules:

1. Install a low-ESR electrolytic capacitor not more than 12 inches from the drive. PWM amplifiers produce ripple currents in their DC supply conductors. R30 amplifiers do not use internal electrolytic capacitors as these can be easily supplied by the printed circuit board. In order to provide a good, low-impedance path for these currents a low-ESR capacitor should be mounted as close to the drive as possible. 330 μ F is a minimum value, with a voltage rating appropriate to the drive model and power supply.
2. Connect P1 signals (U,V,W outputs, +HV, and +HV Common) in pin-groups for current-sharing. The signals on P1 are all high-current types (with the exception of the +24 Vdc Aux HV supply). To carry these high currents (up to 20 Adc peak)

the pins of P1 must be used in multiples to divide the current and keep the current carrying capacity of the connectors within specification. The diagram on page 9 shows the pin groups that must be inter-connected to act as a single connection point for pc board traces.

3. Follow IPC-2221 rules for conductor thickness and minimum trace width of P1 signals. The width and plating should depend on the model of drive used, the maximum voltage, and maximum current expected to be used for that model. Power supply traces (+HV, +HV Common) should be routed close to each other to minimize the area of the loop enclosed by the drive DC power. Noise emission or effects on nearby circuitry are proportional to the area of this loop, so minimizing it is good layout practice.

Motor signals (U,V,W) should also be routed close together. All the motor currents sum to zero, and while the instantaneous value

in a given phase will change, the sum of currents will be zero. So, keeping these traces as closely placed as possible will again minimize noise radiation due to motor phase currents.

R30 circuit grounds are electrically common, and connect internally. However, the P1 signals carry high currents while the grounds on J1 (signal ground) carry low currents. So, J1 signals should be routed away from, and never parallel to the signals on P1. Encoder signal pairs (A, /A, B, /B, and X, /X) should be routed close together for good transmission-line effect to reduce reflections and noise.

The amplifier heatplate is electrically isolated from all drive circuits. For best noise-immunity it is recommended to connect the standoffs to frame ground and to use metal mounting screws to maintain continuity between heatplate and standoffs.

PC BOARD MOUNTING FOOTPRINT

Top View
Dimensions in inches

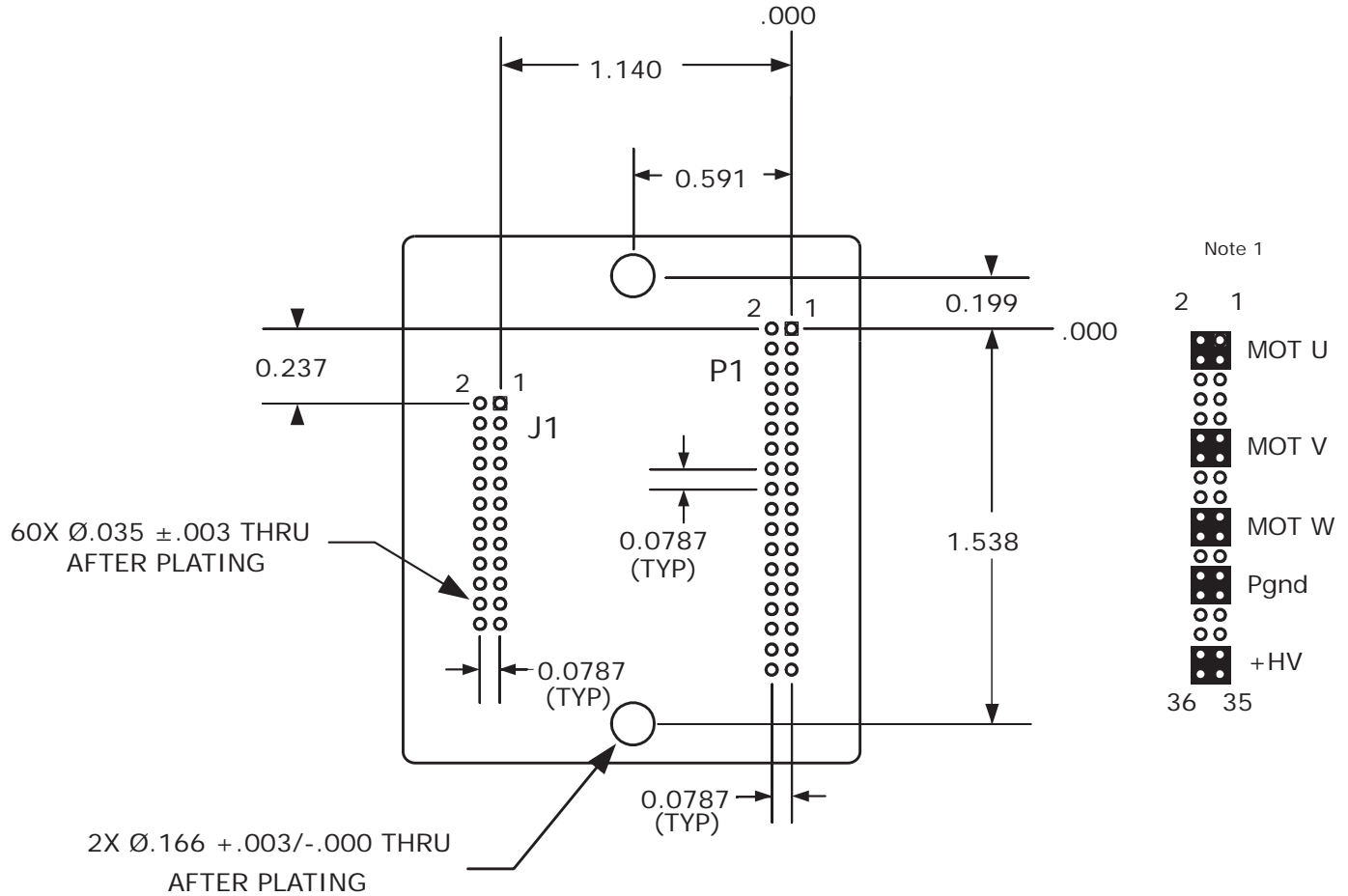

Accelnet Mounting Hardware:

| Qty | Description | Mfgr | Part Number | Remarks |
|-----|--------------|--------|----------------|---------|
| 1 | Socket Strip | Samtec | SQW-112-01-L-D | J1 |
| 1 | Socket Strip | Samtec | SQW-118-01-L-D | P1 |

Notes

1. P1 signals must be connected for current-sharing.
2. To determine copper width and thickness for P1 signals refer to specification IPC-2221. (Association Connecting Electronic Industries, <http://www.ipc.org>)
3. Standoffs should be connected to etches on pc board that connect to frame ground for maximum noise suppression and immunity.

AMPLIFIER PC BOARD CONNECTORS

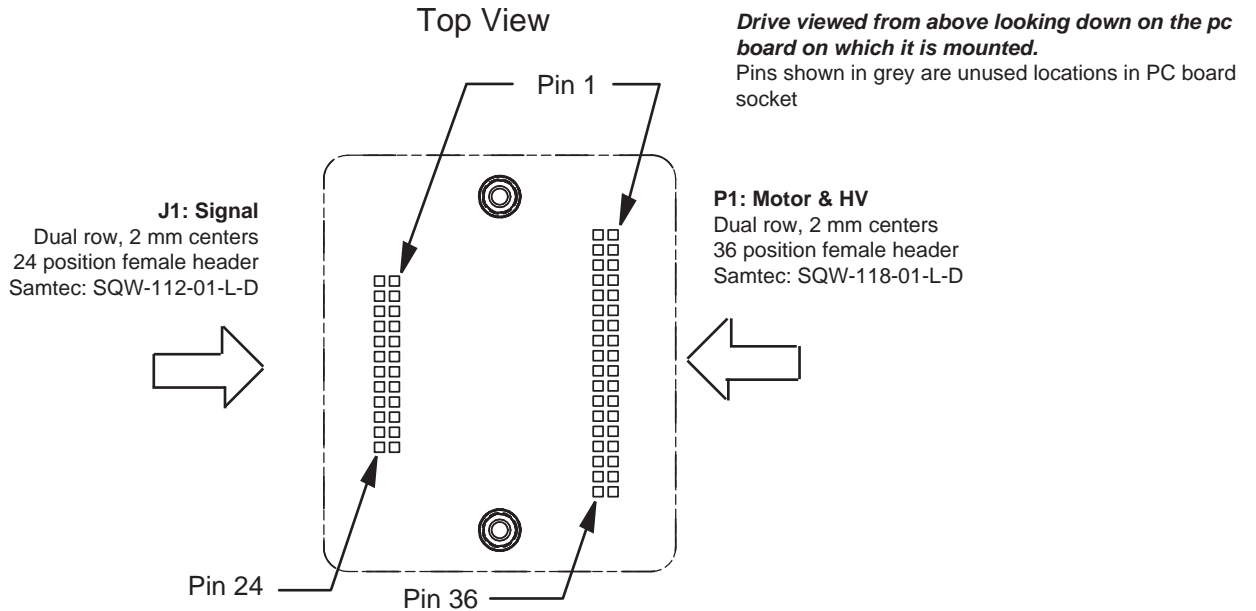

J1 SIGNALS & PINS

| Signal | Pin | Signal | |
|-----------------|-----|--------|-----------------|
| I2T Time | 2 | 1 | Current Ref |
| Peak Curr Limit | 4 | 3 | Ref(+) |
| Cont Curr Limit | 6 | 5 | Agnd |
| PWM Limit | 8 | 7 | Ref(-) |
| /LowInd | 10 | 9 | Balance |
| Hall W | 12 | 11 | Current Monitor |
| Hall V | 14 | 13 | [OUT2] |
| Hall U | 16 | 15 | [OUT1] |
| /Enable | 18 | 17 | [AOK] |
| /NegEnab | 20 | 19 | /PosEnab |
| Hall +5V | 22 | 21 | Hall +5V |
| Pgnd | 24 | 23 | Pgnd |

P1 SIGNALS & PINS

| Signal | Pin | Signal | |
|---------|-----|--------|---------|
| Motor U | 2 | 1 | Motor U |
| Motor U | 4 | 3 | Motor U |
| N/C | 6 | 5 | N/C |
| N/C | 8 | 7 | N/C |
| N/C | 10 | 9 | N/C |
| Motor V | 12 | 11 | Motor V |
| Motor V | 14 | 13 | Motor V |
| N/C | 16 | 15 | N/C |
| N/C | 18 | 17 | N/C |
| Motor W | 20 | 19 | Motor W |
| Motor W | 22 | 21 | Motor W |
| N/C | 24 | 23 | N/C |
| Pgnd | 26 | 25 | Pgnd |
| Pgnd | 28 | 27 | Pgnd |
| N/C | 30 | 29 | N/C |
| N/C | 32 | 31 | N/C |
| +HV | 34 | 33 | +HV |
| +HV | 36 | 35 | +HV |

NOTES

1. Grey-shaded signal are N.C. (No Connection)
2. Signals are grouped for current-sharing on the power connector. When laying out pc board art-works, all pins in groups having the same signal name must be connected.
3. The total current current from J1-21 and J1-22 cannot exceed 250 mA.

AMPLIFIER CONNECTIONS

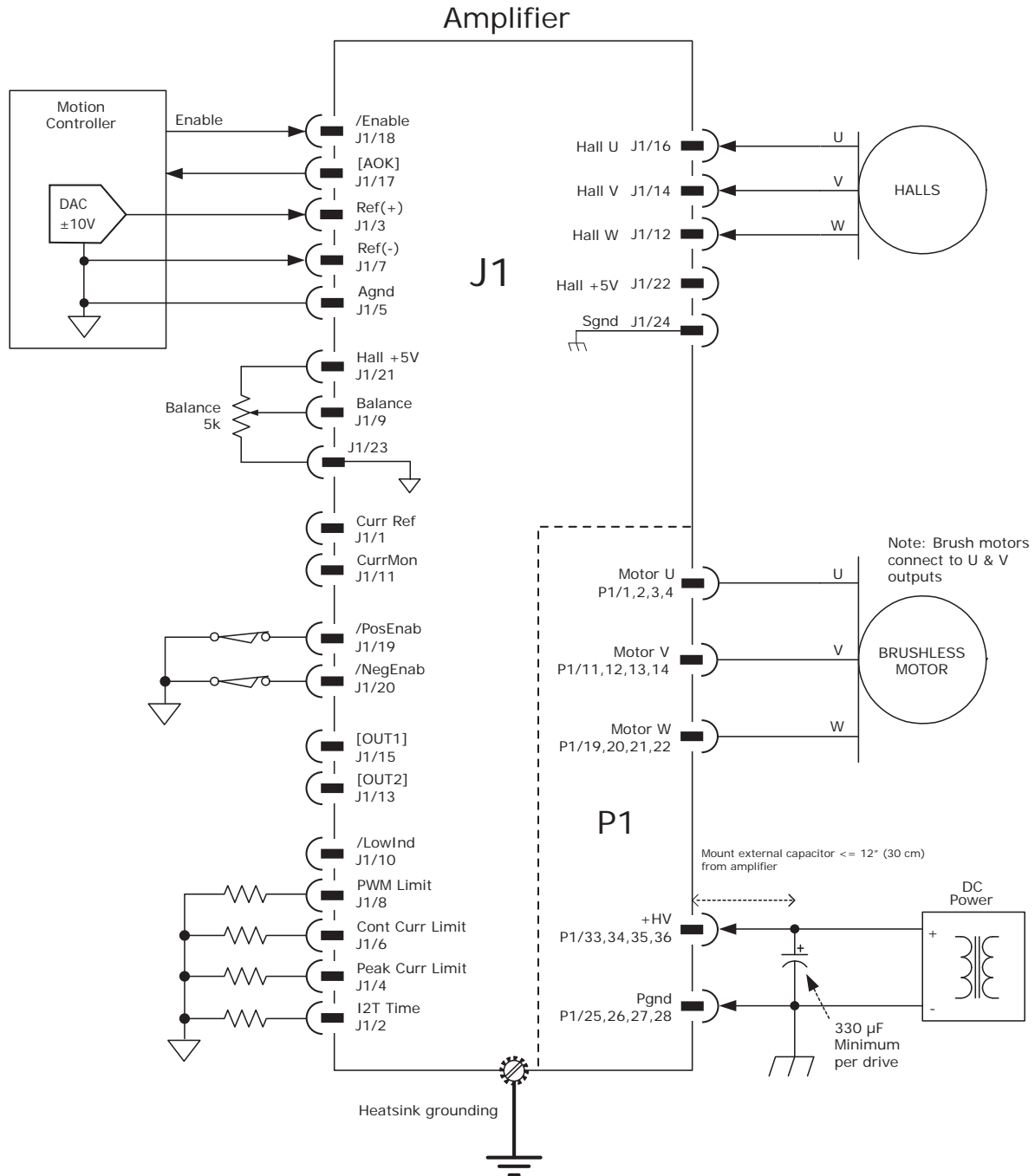

NOTES

1. Total output current from +5V pins (J1-21,22) cannot exceed 250 mA.
2. When Balance potentiometer is used, it should connect to amplifier +5V and ground for best stability.

AMPLIFIER AMBIENT OPERATING TEMPERATURE VS OUTPUT CURRENT AND HV

- 5 = FORCED AIR, 100 LFM, WITH HS
- 4 = FORCED AIR, 20 LFM, WITH HS
- 3 = FORCED AIR, 200 LFM, NO HS
- 2 = CONVECTION, WITH HS
- 1 = CONVECTION, NO HS

Data shown for temperatures below 20C are calculated based on power dissipation and thermal resistance

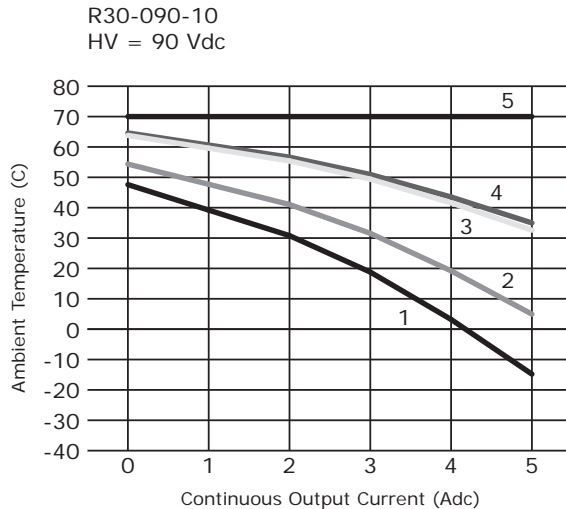
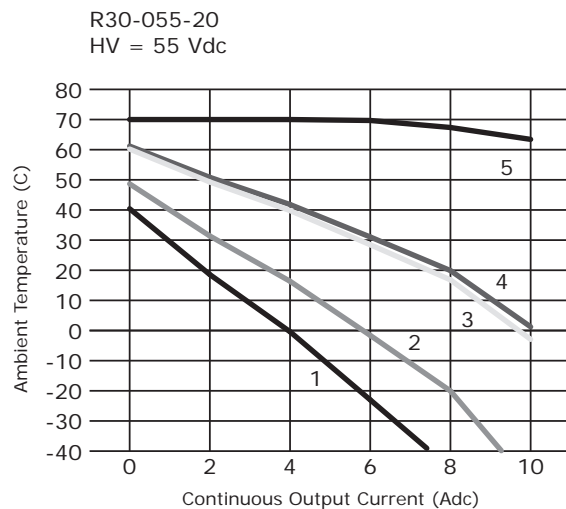
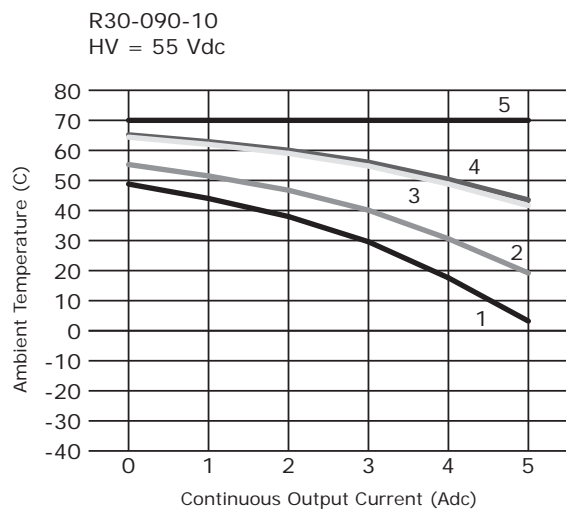
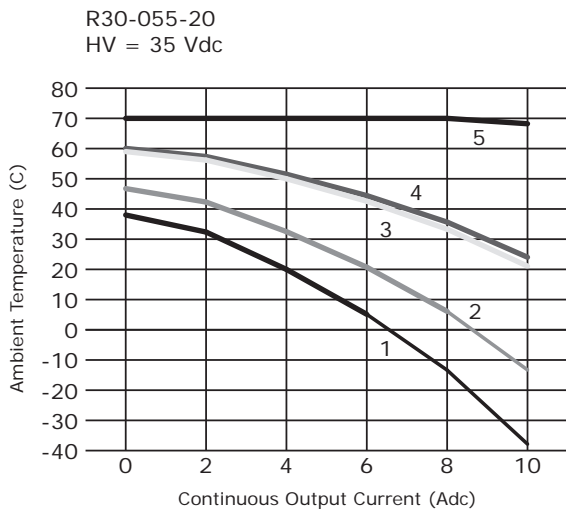
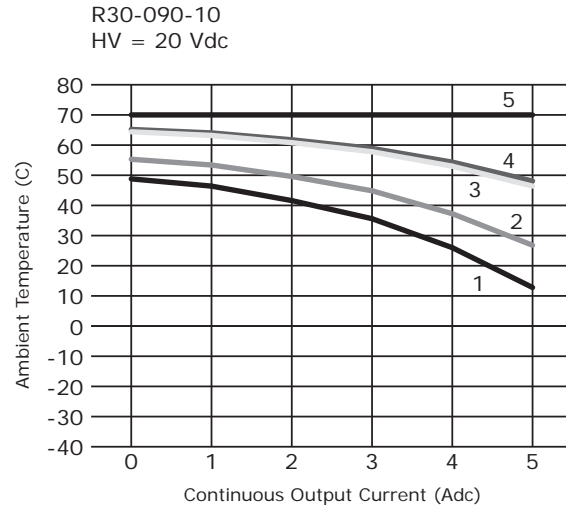
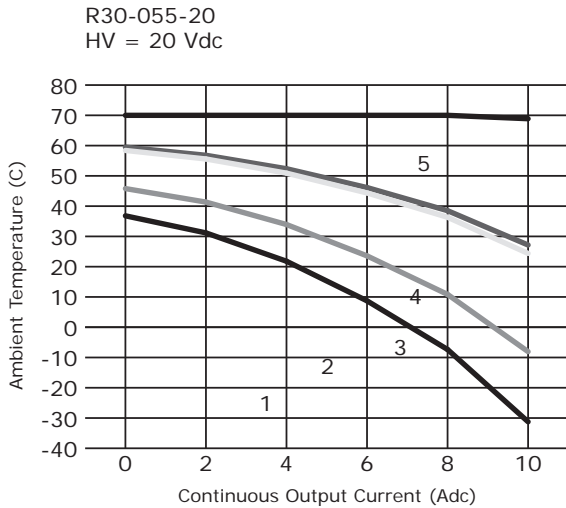

HEATSINK INSTALLATION

If a heatsink is used it is mounted using the same type of screws used to mount the drive without a heatsink but slightly longer. Phase change material (PSM) is used in place of thermal grease. This material comes in sheet form and changes from solid to liquid form as the drive warms up. This forms an excellent thermal path from drive heatplate to heatsink for optimum heat transfer.

STEPS TO INSTALL

1. Remove the PSM (Phase Change Material) from the clear plastic carrier.
2. Place the PSM on the R30 aluminum heatplate taking care to center the PSM holes over the holes in the drive body.
3. Mount the heatsink onto the PSM again taking care to see that the holes in the heatsink, PSM, and drive all line up.
4. Torque the #4-40 mounting screws to 8~10 lb-in (0.9~1.13 N·m).

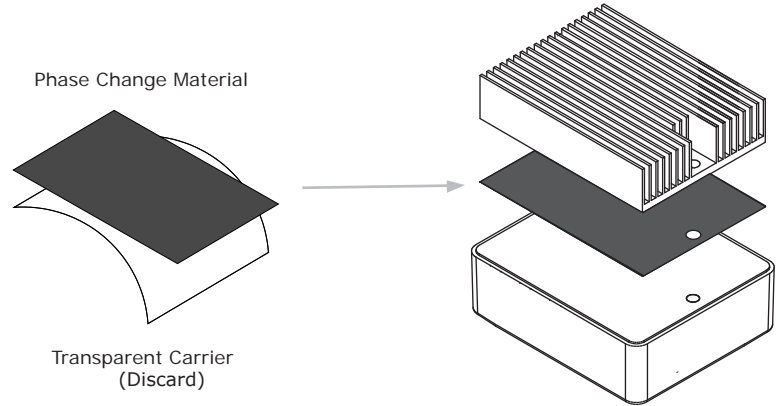

DEVELOPMENT KIT TOP VIEW

The graphic below shows the placement of components and connectors on the Development Kit PC board. The R30 amplifier is not shown, but mounts in the outline that contains connectors J3 & J2.

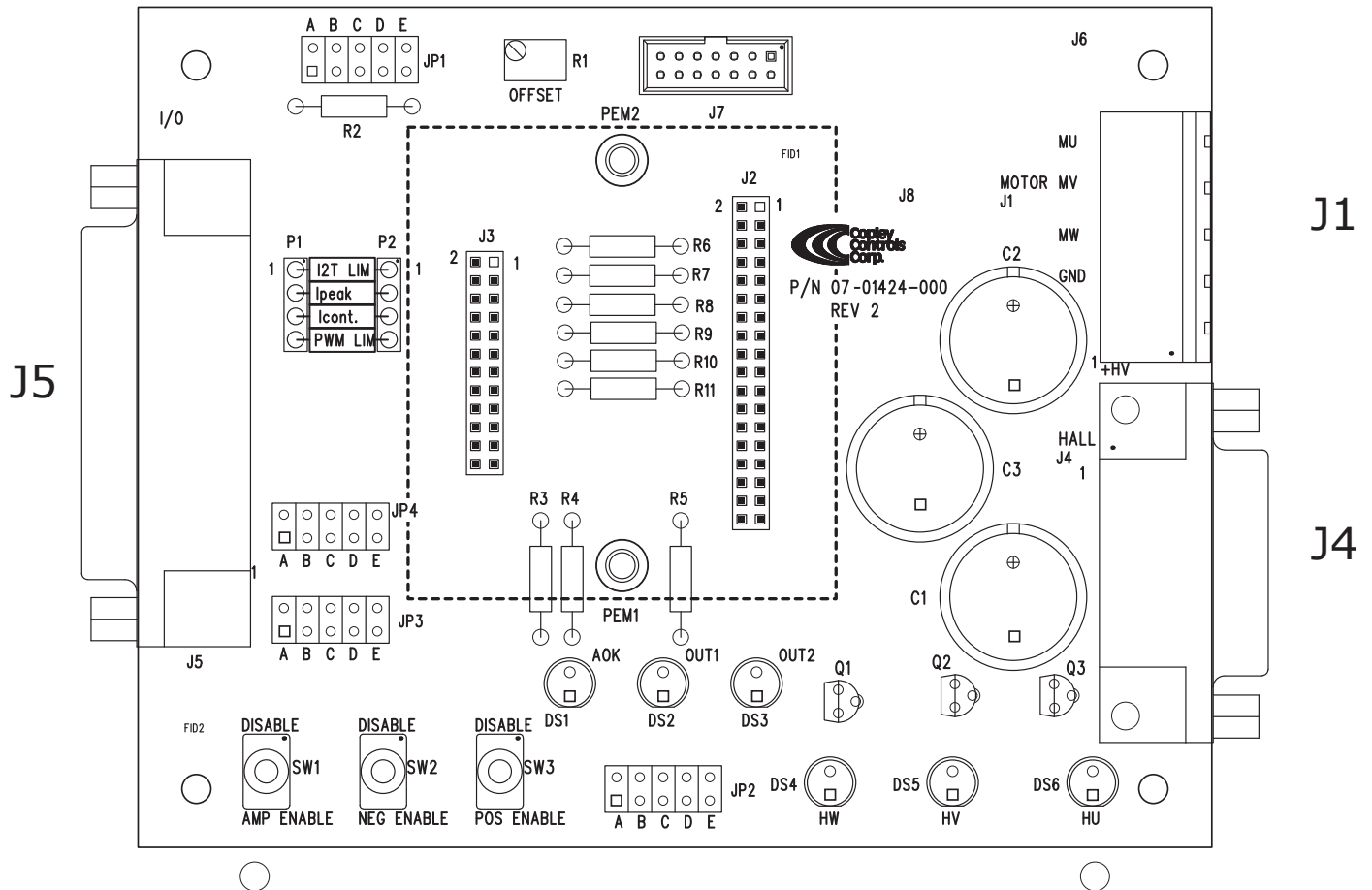

SOCKETED COMPONENTS

| P1/P2 | Remarks |
|-------|---------------------------|
| 1 | I2T Time setting resistor |
| 2 | Ipeak setting resistor |
| 3 | Icont setting resistor |
| 4 | No function |

CONNECTORS

These charts show the pins and signals for the Development Kit connectors.

J1 MOTOR AND HV POWER

| Pin | Signal |
|-----|-----------|
| 5 | Mot U |
| 4 | Mot V |
| 3 | Mot W |
| 2 | HV Gnd |
| 1 | +HV Input |

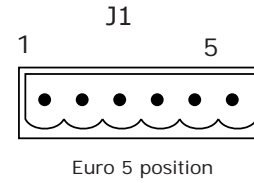

J4 HALLS

| Signal | Pin | Signal |
|--------|------|---------------|
| Sgnd | 1 9 | n.c. |
| Hall U | 2 10 | Sgnd |
| Hall V | 3 11 | +5 Vdc output |
| Hall W | 4 12 | Sgnd |
| Sgnd | 5 13 | n.c. |
| n.c. | 6 14 | n.c. |
| n.c. | 7 15 | n.c. |
| n.c. | 8 | |

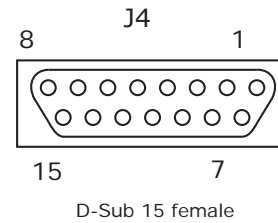

J5 CONTROL

| Signal | Pin | Signal |
|--------------------|-------|-----------------|
| Sgnd | 1 14 | Ref(-) |
| Ref(+) | 2 15 | Sgnd |
| Ext Balance | 3 16 | Sgnd |
| /NegEnab | 4 17 | /PosEnab |
| /Enable | 5 18 | Gain Select |
| [OUT1] | 6 19 | Sgnd |
| Current Cont Limit | 7 20 | n.c. |
| Current Ref | 8 21 | Curr Peak Limit |
| I2T Time | 9 22 | [AOK] |
| Current Monitor | 10 23 | +5 Vdc Output |
| [OUT2] | 11 24 | n.c. |
| Sgnd | 12 25 | n.c. |
| Sgnd | 13 | |

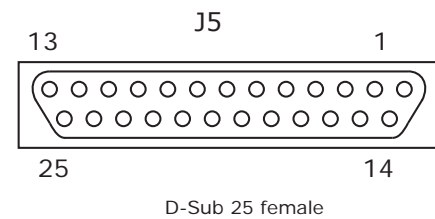

NOTES

1) The combined current from J4-11 and J5-23 cannot exceed 250 mA.

CONNECTIONS

In the diagram below, connectors inside the R30 outline are the amplifier connectors, their signal names, and pin numbers. All connectors and components outside of the R30 are on the Development Kit.

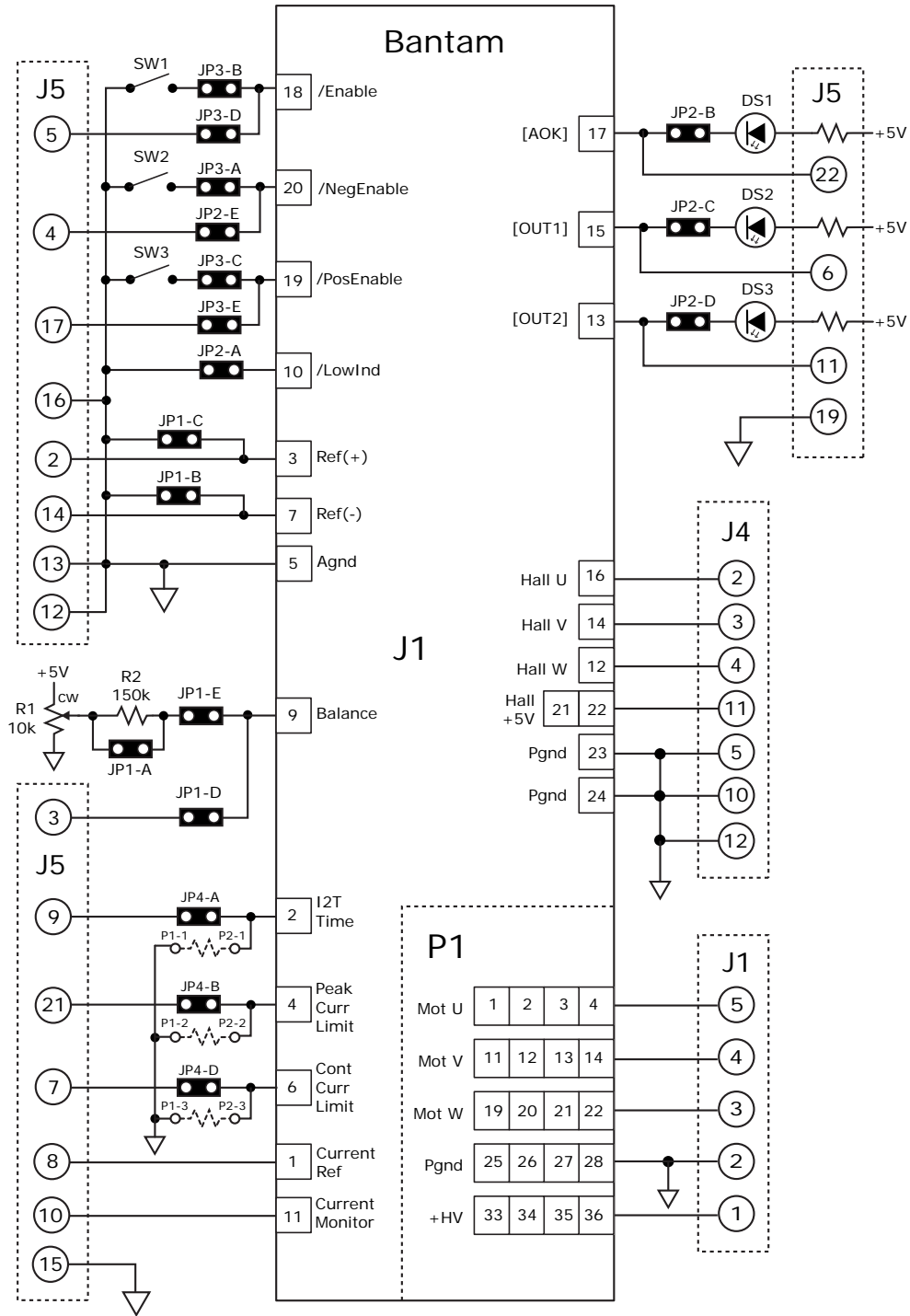

NOTES

1) The combined current from J4-11 and J5-23 cannot exceed 250 mA.

JUMPER FUNCTIONS

The functions shown in the tables below are in effect when the jumper is in place.
 When a jumper is removed, the stated function is disabled.
 J5 connects to an external controller

JP1

| JP1 | Remarks |
|-----|-------------------------------|
| A | Shorts 150k balance scaler |
| B | Ref(-) input is grounded |
| C | Ref(+) input is grounded |
| D | Connects J5-3 to Amp: Balance |
| E | R1 controls Amp: Balance |

JP2

| JP2 | Remarks |
|-----|--------------------------------|
| A | Gain Select to Sgnd |
| B | Amp: [AOK] drives DS1 |
| C | Amp: [OUT1] drives DS2 |
| D | Amp: [OUT2] drives DS3 |
| E | Connects J5-4 to Amp: /NegEnab |

JP3

| JP3 | Remarks |
|-----|---------------------------------|
| A | Connects SW2 to Amp: /NegEnab |
| B | Connects SW1 to Amp: /Enable |
| C | Connects SW3 to Amp: /PosEnab |
| D | Connects J5-5 to Amp: /Enable |
| E | Connects J5-17 to Amp: /PosEnab |

JP4

| JP4 | Remarks |
|-----|---|
| A | Connects J5-9 to Amp: I2T Time |
| B | Connects J5-21 to Amp: Current Peak Limit |
| C | No connections |
| D | Connects J5-7 to Amp: Current Cont Limit |
| E | Connects J5-18 to Amp: Gain Select |

MASTER ORDERING GUIDE

| | |
|------------|---|
| R30-055-20 | R30 analog current amplifier, 10/20 Adc |
| R30-090-10 | R30 analog current amplifier, 5/10 Adc |
| BDK-090-01 | Development kit |
| BDK-CK | Connector Kit for Development Kit |

ORDERING EXAMPLE

Example: Order 1 R30-055-20 current amplifier and development kit:

| Qty | Item | Remarks |
|-----|------------|-----------------------------------|
| 1 | R30-055-20 | R30 current amplifier |
| 1 | BDK-090-01 | Development Kit for R30 amplifier |
| 1 | BDK-CK | Connector Kit for Development Kit |

ACCESSORIES

| ORDER NUMBER | Qty | Ref | DESCRIPTION |
|---|-----|-----|--|
| BDK-CK Connector kit for BDK-090-01 Development Kit (includes next 5 items shown below) | | | |
| | 1 | J1 | Connector, RoHS, Euro style plug, 5 position, Tyco (AMP) 796635-5 |
| | 1 | J4 | Connector, D-Sub, 15-position, male, RoHS, Tyco (AMP) 5-747908-2 |
| | 1 | J4 | Backshell, D-Sub, RoHS, metallized, 15-position, Norcomp 979-015-020R121 |
| | 1 | J5 | Connector, D-Sub, 25-position, male, RoHS, Tyco (AMP) 5-747912-2 |
| | 1 | J5 | Backshell, D-Sub, RoHS, metallized, 25-position, Norcomp 979-025-020R121 |

HEATSINK (OPTIONAL)

| | | |
|------------------------|---|---|
| Heatsink Kit BTM-HK | 1 | Heatsink kit (for field-installation by customer) |
| | 1 | Heatsink Thermal Phase-change Material |
| | 4 | Heatsink hardware (#4-40 screws) |