

Control Modes

- Cyclic Synchronous Position-Velocity-Torque (CSP, CSV, CST)
- Profile Position-Velocity-Torque, Interpolated Position, Homing
- Camming, Gearing
- Indexer

DIGITAL SERVO DRIVE
FOR BRUSH/BRUSHLESS MOTORS

EtherCAT 

Command Interface

- CAN application layer over EtherCAT (CoE)
- ASCII and discrete I/O
- Stepper commands
- ±10V position/velocity/torque (2 inputs)
- PWM velocity/torque command
- Master encoder (Gearing/Camming)

Communications

- EtherCAT
- RS-232

Accessories

- External regen resistors
- External edge filter

Feedback

- Digital quad A/B encoder
Analog sin/cos incremental
Panasonic Incremental A Format
- SSI, EnDat, Absolute A
Tamagawa & Panasonic Absolute A
Sanyo Denki Absolute A,
BiSS, BiSS
- Aux. encoder / encoder out
- Resolver option
- Digital Halls

Safe Torque Off (STO)

- Two active inputs enable power stage
- One output confirms power stage status

I/O Digital

- 15 inputs, 6 outputs

I/O Analog

- 2, 16 bit inputs
- 1, 12-bit input
- 1, 12 bit output

Dimensions: in [mm]

- 7.9 x 5.5 x 2.3 [202 x 139 x 52]



Model	I _c	I _p	V _{ac}
XEL-230-18	6	18	100-240
XEL-230-36	12	36	100-240
XEL-230-40	20	40	100-240

Add -R for resolver feedback option.

DESCRIPTION

Xenus Plus set new levels of performance, connectivity, and flexibility. Ethernet based EtherCAT operates in CAN application layer over EtherCAT (CoE) mode. A wide range of absolute interfaces are built-in including EnDat, and BiSS.

High resolution A/D converters ensure optimal current loop performance. Both isolated and high-speed non-isolated I/O are provided. For safety critical applications, redundant power stage enable inputs can be employed.

GENERAL SPECIFICATIONS

Test conditions: Wye connected load: 2 mH line-line. Ambient temperature = 25 °C. Power input = 230 Vac, 60 Hz, 1 Ø

MODEL	XEL-230-18	XEL-230-36	XEL-230-40	
OUTPUT CURRENT				
Peak Current	18 (12.7)	36 (25.5)	40 (28.3)	Adc (Arms, sinusoidal)
Peak time	1	1	1	s
Continuous current (Note 1)	6 (4.24)	12 (8.5)	20 (14.1)	Adc (Arms, sinusoidal)
INPUT POWER				
Mains voltage, phase, frequency	100~240			Vac, ±10%, 1Ø or 3Ø, 47~63 Hz
Maximum Mains Current, 1Ø (Note 3)	10.1	20.0	20.0	Arms
Maximum Mains current, 3Ø (Note 3)	6.4	10.4	15.4	Arms
+24 Vdc Control power	+20 to +32 Vdc, 500 mA max			Required for operation
DIGITAL CONTROL				
Digital Control Loops	Current, velocity, position. 100% digital loop control			
Sampling rate (time)	Current loop: 16 kHz (62.5 µs), Velocity & position loops: 4 kHz (250 µs)			
Bus voltage compensation	Changes in bus or mains voltage do not affect bandwidth			
Minimum load inductance	200 µH line-line			
COMMAND INPUTS				
<i>Distributed Control Mode</i>				
CAN application layer over EtherCAT (CoE)	Cyclic Synchronous Position-Velocity-Torque, Profile Position-Velocity-Torque, Interpolated Position, Homing			
<i>Stand-alone mode</i>				
Analog torque, velocity, position reference	±10 Vdc, 16 bit resolution		Dedicated differential analog input	
Digital position reference	Pulse/Direction, CW/CCW		Stepper commands (2 MHz maximum rate)	
	Quad A/B Encoder		2 M line/sec, 8 Mcount/sec (after quadrature)	
	PWM, Polarity		PWM = 0% - 100%, Polarity = 1/0	
Digital torque & velocity reference	PWM 50%		PWM = 50% ±50%, no polarity signal required	
	PWM frequency range		1 kHz minimum, 100 kHz maximum	
	PWM minimum pulse width		220 ns	
Indexing	Up to 32 programs can be launched from inputs or ASCII commands.			
Camming	Up to 10 CAM tables can be stored in flash memory			
DIGITAL INPUTS				
Number	15			
[IN1,2]	Non-isolated Schmitt trigger, 1 µs RC filter, 24 Vdc max, V ₊ = 2.5~3.5 Vdc, V ₋ = 1.3~2.2 Vdc, V _{H+} = 0.7~1.5 Vdc			
	10 kΩ programmable per input to pull-up to +5 Vdc or pull-down to ground			
[IN3~6]	Non-isolated line receiver, 100 ns RC filter, +12 Vdc max, programmable as 4 single-ended, or 2 differential			
	Single-ended: [IN3,4] or [IN5,6]: Vin-LO <= 2.3 Vdc, Vin-HI >= 2.7 Vdc, Vhysteresis = 400 mVdc			
	Differential: [IN3/4] or [IN5/6]: Vin-LO <= -200 mVdc, Vin-HI >= 200 mVdc, Vhysteresis = ±200 mVdc			
[IN7~14]	Opto-isolated, ±15~30 Vdc compatible, bi-polar, 2 groups of 4 with common for each group			
[ENCLFT]	Encoder fault: same electrical specs as [IN1,2,15] except 10 kΩ fixed pull-up to +5 Vdc			
ANALOG INPUTS				
Number	3			
[AIN1~2]	Differential, ±10 Vdc, 5 kΩ input impedance, 16-bit resolution			
[AIN3]	Single-ended, motor temperature sensor, 4.99 kΩ pulled-up to +5 Vdc, 12-bit resolution			
DIGITAL OUTPUTS				
Number	6			
[OUT1~2]	Current-sinking MOSFET with 1 kΩ pullup to +5 Vdc through diode			
	1 Adc max, +40 Vdc max; external flyback diode required if driving inductive loads			
[OUT3]	High-speed CMOS buffer, ±32 mA			
[OUT4~5]	Opto-isolated Darlington with 36V Zener flyback diodes, 20 mA max			
[OUT6]	Motor brake control: opto-isolated, current-sinking with flyback diode to +24 Vdc, 1 Adc max			
ANALOG OUTPUT				
Number	1			
Range	±5 Vdc single-ended, 12-bit resolution			
MULTI-MODE ENCODER PORT				
As Input	Secondary digital quadrature encoder (A, /A, B, /B, X, /X), 121 Ω terminating resistors			
	18 M-counts/sec, post-quadrature (4.5 M-lines/sec)			
As Output	Quadrature encoder emulation with programmable resolution to 4096 lines (65,536 counts) per rev			
	from analog sin/cos encoders or resolvers. Buffered signals from digital quad A/B/X primary encoder			
	A, /A, B, /B, X, /X, from MAX3032 differential line driver			
RS-232 PORT				
Signals	RxD, TxD, Gnd in 6-position, 4-contact RJ-11 style modular connector			
Mode	Full-duplex, DTE serial communication port for drive setup and control, 9,600 to 115,200 Baud			
Protocol	Binary and ASCII formats			
ETHERCAT PORTS				
Format	Dual RJ-45 receptacles, 100BASE-TX			
Protocol	EtherCAT, CAN application layer over EtherCAT (CoE)			
STATUS INDICATORS				
Drive Status	Bicolor LED, drive status indicated by color, and blinking or non-blinking condition			
NET Status	Bicolor LED, status of EtherCAT bus indicated by color and blink codes to CAN Indicator Specification 303-3			
5V OUTPUT				
	Two independent 5 Vdc @ 400 mA outputs: J8-20 and J10-6,17			

NOTES:

1. Heatsinking and/or forced-air cooling is required for the continuous output power rating
2. Brake[OUT6] is programmable as motor brake, or as general purpose digital output
3. The actual mains current is dependent on the mains voltage, number of phases, and motor load and operating conditions. The Maximum Mains Currents shown above occur when the drive is operating from the maximum input voltage and is producing the rated continuous output current at the maximum output voltage.

REGENERATION

Operation	Internal solid-state switch drives external regen resistor (see Ordering Guide for types)	
Cut-In Voltage	+HV > 390 Vdc	Regen output is on, (optional external) regen resistor is dissipating energy
Drop-Out Voltage	+HV < 380 Vdc	Regen output is off, (optional external) regen resistor not dissipating energy
Tolerance	±2 Vdc	For either Cut-In or Drop-Out voltage

PROTECTIONS

Mains power loss	Interruption or loss of AC power is detected	
HV Overvoltage	+HV > 400 Vdc	Drive PWM outputs turn off until +HV is less than overvoltage
HV Undervoltage	+HV < 60 Vdc	Drive PWM outputs turn off until +HV is greater than undervoltage
Drive over temperature	IGBT > 80 °C ±3 °C	Drive PWM outputs turn off until IGBT temperature is below threshold
Short circuits	Output to output, output to ground, internal PWM bridge faults, regen resistor fail-shorts	
I ² T Current limiting	Programmable: continuous current, peak current, peak time	
Motor over temperature	Programmable input to disable drive when voltage is above or below a set point 0~5 Vdc	
Feedback power loss	Fault occurs if feedback is removed or +5 V is <85% of normal	

MECHANICAL & ENVIRONMENTAL

Size	7.55 in (191,8 mm) X 5.57 in (141,5 mm) X 2.57 in (65,3 mm)	
Weight	3.0 lb (1.36 kg) for drive without heatsink 3.1 lb (1.40 kg) for XEL-HS heatsink, 1.86 lb (0.84 kg) for XEL-HL heatsink	
Ambient temperature	0 to +45 °C operating, -40 to +85 °C storage	
Humidity	0% to 95%, non-condensing	
Contaminants	Pollution degree 2	
Vibration	2 g peak, 10~500 Hz (sine), IEC60068-2-6	
Shock	10 g, 10 ms, half-sine pulse, IEC60068-2-27	
Environment	IEC68-2: 1990	
Cooling	Heat sink and/or forced air cooling required for continuous power output	

AGENCY STANDARDS CONFORMANCE

In accordance with EC Directive 2004/108/EC (EMC Directive)

EN 55011: 2007	CISPR 11:2003/A2:2006 Industrial, Scientific, and Medical (ISM) Radio Frequency Equipment – Electromagnetic Disturbance Characteristics – Limits and Methods of Measurement Group 1, Class A
EN 61000-6-1: 2007	Electromagnetic Compatibility (EMC) – Part 6-1: Generic Standards – Immunity for residential, Commercial and Light-industrial Environments

In accordance with EC Directive 2006/95/EC (Low Voltage Directive)

IEC 61010-1:2001	Safety Requirements for Electrical Equipment for Measurement, Control and Laboratory Use
------------------	--

Underwriters Laboratory Standards

UL 61010-1, 2nd Ed.: 2004 UL File Number E249894	Safety Requirements for Electrical Equipment for Measurement, Control and Laboratory Use
---	--

FEEDBACK SPECIFICATIONS

DIGITAL QUAD A/B ENCODER

Type	Quadrature, differential line driver outputs
Signals	A, /A, B, /B, (X, /X, index signals optional) RS-422/RS-485 line receivers with fault detection for open/shorted inputs, or low signal amplitude
Frequency	5 MHz line frequency, 20 MHz quadrature count frequency

ANALOG ENCODER

Type	Sin/cos/index, differential line driver outputs, 0.5 V _{peak-peak} (1.0 V _{peak-peak} differential) centered about 2.5 Vdc typical. Common-mode voltage 0.25 to 3.75 Vdc
Signals	Sin(+), sin(-), cos(+), cos(-), index(+), index(-)
Frequency	230kHz maximum line (cycle) frequency
Interpolation	10 bits/cycle (1024 counts/cycle)

DIGITAL HALLS

Type	Digital, single-ended, 120° electrical phase difference
Signals	U, V, W
Inputs	10 kΩ pullups to +5 Vdc, 1 μs RC filter to Schmitt trigger inverters

MULTI-MODE ENCODER PORT

As Input	Secondary digital quadrature encoder (A, /A, B, /B, X, /X), 121 Ω terminating resistors 18 M-counts/sec, post-quadrature (4.5 M-lines/sec)
As Emulated Output	Quadrature encoder emulation with programmable resolution to 4096 lines (65,536 counts) per rev from analog sin/cos encoders or resolvers.
As Buffered Output	A, /A, B, /B, X, /X, from MAX3032 differential line driver Digital encoder feedback signals from primary digital encoder are buffered by MAX3032 line driver

RESOLVER (-R OPTION)

Type	Brushless, single-speed, 1:1 to 2:1 programmable transformation ratio
Resolution	14 bits (equivalent to a 4096 line quadrature encoder)
Reference frequency	7.5 kHz
Reference voltage	2.8 Vrms, auto-adjustable by the drive to maximize feedback
Reference maximum current	100 mA
Maximum RPM	10,000+

ENCODER POWER SUPPLIES

Number	2
Ratings	+5 Vdc @ 400 mA from J10-6 and J8-20
Protection	Current-limited to 750 mA @ 1 Vdc if overloaded Encoder power developed from +24 Vdc so position information is not lost when AC mains power is removed

SPECIFICATIONS (CONT'D)

SAFE TORQUE OFF (STO)

Inputs	2 two-terminal: [ENH+], [ENH-], [ENL+], [ENL-]
Type	Opto-isolators, 24V compatible
Output	1 two-terminal: [LED+], [LED-] 24V compatible

DIMENSIONS

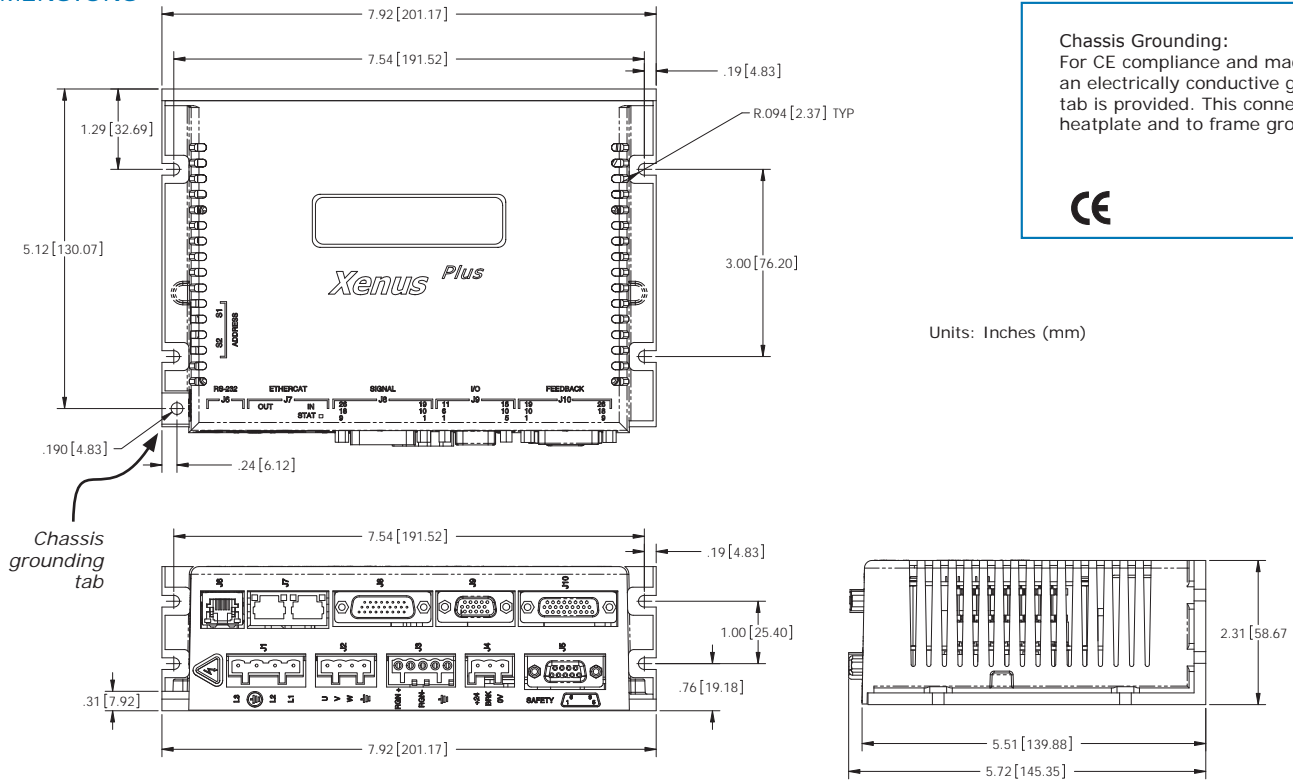

Chassis Grounding:
For CE compliance and machine safety an electrically conductive grounding tab is provided. This connects to the heatplate and to frame ground.



Units: Inches (mm)



Note!
When you see this marker, it's for hot tips or best practices that will help you get the best results when using Copley Controls products.

ETHERCAT COMMUNICATIONS

EtherCAT is the open, real-time Ethernet network developed by Beckhoff based on the widely used 100BASE-TX cabling system. EtherCAT enables high-speed control of multiple axes while maintaining tight synchronization of clocks in the nodes. Data protocol is CAN application layer over EtherCAT (CoE) based on DSP-402 for motion control devices. More information on EtherCAT can be found on this web-site: <http://ethercat.org/default.htm>

ETHERCAT CONNECTIONS

Dual RJ-45 sockets accept standard Ethernet cables. The IN port connects to a master, or to the OUT port of a device that is 'upstream', between the Xenus and the master. The OUT port connects to 'downstream' nodes. If Xenus is the last node on a network, only the IN port is used. No terminator is required on the OUT port.

J7: EtherCAT PORTS

RJ-45 receptacles, 8 position, 4 contact

PIN	SIGNAL
6	RX-
3	RX+
2	TX-
1	TX+

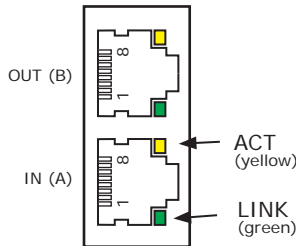

ETHERCAT LINK & ACTIVITY LEDS (ON J7)

These LEDs show the state of the physical link and activity on the link

Link	Act	Remarks
On	Off	Port open, no activity
On	Flickering	Port open, network activity
Off	No	Port closed

J6: RS-232 PORT

RJ-12 receptacle, 6 position, 4 contact

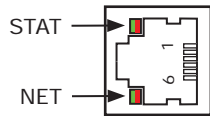

STAT LED

A bi-color LED gives the status of the Xenus Plus drive. Colors do not alternate, and can be solid ON or blinking:

- Green/Solid = Drive OK and enabled. Will run in response to reference inputs or EtherCAT commands.
- Green/Slow-Blinking = Drive OK but NOT-enabled. Will run when enabled.
- Green/Fast-Blinking = Positive or Negative limit switch active. Drive will only move in direction not inhibited by limit switch.
- Red/Solid = Transient fault condition. Drive will resume operation when fault is removed.
- Red/Blinking = Latching fault. Operation will not resume until drive is Reset.

NET LED

A bi-color LED (NET) indicates the status of the EtherCAT state machine and occurrence of errors. Green and red colors alternate: Green = RUN, Red = ERROR

RUN (green)	ERROR (red)
Off = INITIALIZATION	Off = No error
Blinking = PRE-OPERATIONAL	Blinking = Invalid configuration (note 1)
Single Flash = SAFE-OPERATIONAL	Single Flash = Local error (note 2)
On = OPERATIONAL	Double Flash = Watchdog timeout (note 3)

Notes:

- 1) A change of state commanded by the master is not possible or is illegal
- 2) This indicates that the slave has initiated a change of state by itself in response to an error
- 3) The EtherCAT watchdog timer has timed-out

EtherCAT ADDRESS (STATION ALIAS)

In an EtherCAT network, slaves are automatically assigned addresses based on their position in the bus. But when the device must have a positive identification that is independent of cabling, a Station Alias is needed. In the XEL, this is provided by two 16-position rotary switches with hexadecimal encoding. These can set the address of the drive from 0x01~0xFF (1~255 decimal). The chart shows the decimal values of the hex settings of each switch.

Example 1: Find the switch settings for decimal address 107:

- 1) Find the highest number under S1 that is less than 107 and set S1 to the hex value in the same row:
96 < 107 and 112 > 107, so S1 = 96 = Hex 6
- 2) Subtract 96 from the desired address to get the decimal value of switch S2 and set S2 to the Hex value in the same row:
S2 = (107 - 96) = 11 = Hex B

EtherCAT Address Switch Decimal values

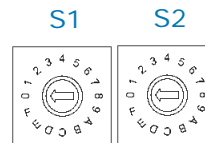

	S1	S2
Hex	Dec	
0	0	0
1	16	1
2	32	2
3	48	3
4	64	4
5	80	5
6	96	6
7	112	7
8	128	8
9	144	9
A	160	10
B	176	11
C	192	12
D	208	13
E	224	14
F	240	15

COMMUNICATIONS

RS-232 COMMUNICATIONS

XEL is configured via a three-wire, full-duplex DTE RS-232 port that operates from 9600 to 115,200 Baud, 8 bits, no parity, and one stop bit. Signal format is full-duplex, 3-wire, DTE using RxD, TxD, and Gnd. Connections to the XEL RS-232 port are through J7, an RJ-11 connector. The XEL Serial Cable Kit (SER-CK) contains a modular cable, and an adapter that connects to a 9-pin, Sub-D serial port connector (COM1, COM2, etc.) on PC's and compatibles.

J6: RS-232 PORT

RJ-12 receptacle, 6 position, 4 contact

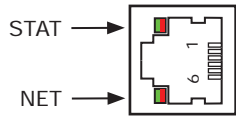

PIN	SIGNAL
2	RxD
3,4	Gnd
5	TxD

STAT LED (ON J6)

A bi-color LED gives the state of the Xenus Plus drive.

Colors do not alternate, and can be solid ON or blinking:

- Green/Solid = Drive OK and enabled. Will run in response to reference inputs or EtherCAT commands.
- Green/Slow-Blinking = Drive OK but NOT-enabled. Will run when enabled.
- Green/Fast-Blinking = Positive or Negative limit switch active. Drive will only move in direction not inhibited by limit switch.
- Red/Solid = Transient fault condition. Drive will resume operation when fault is removed.
- Red/Blinking = Latching fault. Operation will not resume until drive is Reset.

Drive Fault conditions:

- Over or under-voltage
- Encoder +5 Vdc fault
- Short-circuits from output to output
- Internal short circuits
- Motor over-temperature
- Drive over-temperature
- Short-circuits from output to ground

Faults are programmable to be either transient or latching

SER-CK SERIAL CABLE KIT

The SER-CK provides connectivity between a D-Sub 9 male connector and the RJ-11 connector on the XEL. It includes an adapter that plugs into the COM1 (or other) port of a PC and uses common modular cable to connect to the XEL. The connections are shown in the diagram below.

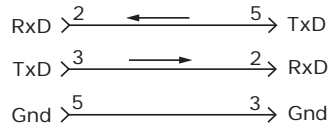
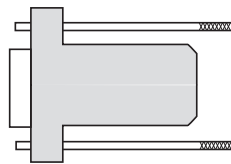
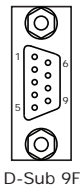

Don't forget to order a Serial Cable Kit SER-CK when placing your order for an XEL!

ASCII COMMUNICATIONS

The Copley ASCII Interface is a set of ASCII format commands that can be used to operate and monitor Copley Controls Accelnet, Stepnet, and Xenus series amplifiers over an RS-232 serial connection. For instance, after basic amplifier configuration values have been programmed using CME 2, a control program can use the ASCII Interface to:

- Enable the amplifier in Programmed Position mode.
- Home the axis.
- Issue a series of move commands while monitoring position, velocity, and other run-time variables.

Additional information can be found in the ASCII Programmers Guide on the Copley website:

http://www.copleycontrols.com/Motion/pdf/ASCII_ProgrammersGuide.pdf

SAFE TORQUE OFF (STO)

DESCRIPTION

The XEL has a safety feature that is designed to provide the Safe Torque Off (STO) function as defined in IEC 61800-5-2. Two opto-couplers are provided which, when de-energized, prevent the upper and lower devices in the PWM outputs from being operated by the digital control core. This provides a positive OFF capability that cannot be overridden by the control firmware, or associated hardware components. When the opto-couplers are activated (current is flowing in the input diodes), the control core will be able to control the on/off state of the PWM outputs.

FUNCTIONAL DIAGRAM

In order for the PWM outputs of the Xenus Plus to be activated, current must be flowing through both opto-couplers that are connected to the ENH and ENL terminals of J5, and the drive must be in an ENABLED state. The LED outputs on J5 connect an opto-coupler to an external LED and will conduct current through the LED to light it whenever the PWM outputs can be activated, or the drive is in a diagnostic state. When the LED opto-coupler is OFF, the drive is in a Safe state and the PWM outputs cannot be activated to drive a motor.

STO OVERRIDE

The diagram below shows connections that will energize both ENH and ENL opto-couplers. When this is done the STO feature is defeated and control of the output PWM stage is under control of the digital control core. If not using the STO feature, these connections must be made in order for the Xenus to be enabled.

FUNCTIONAL DIAGRAM

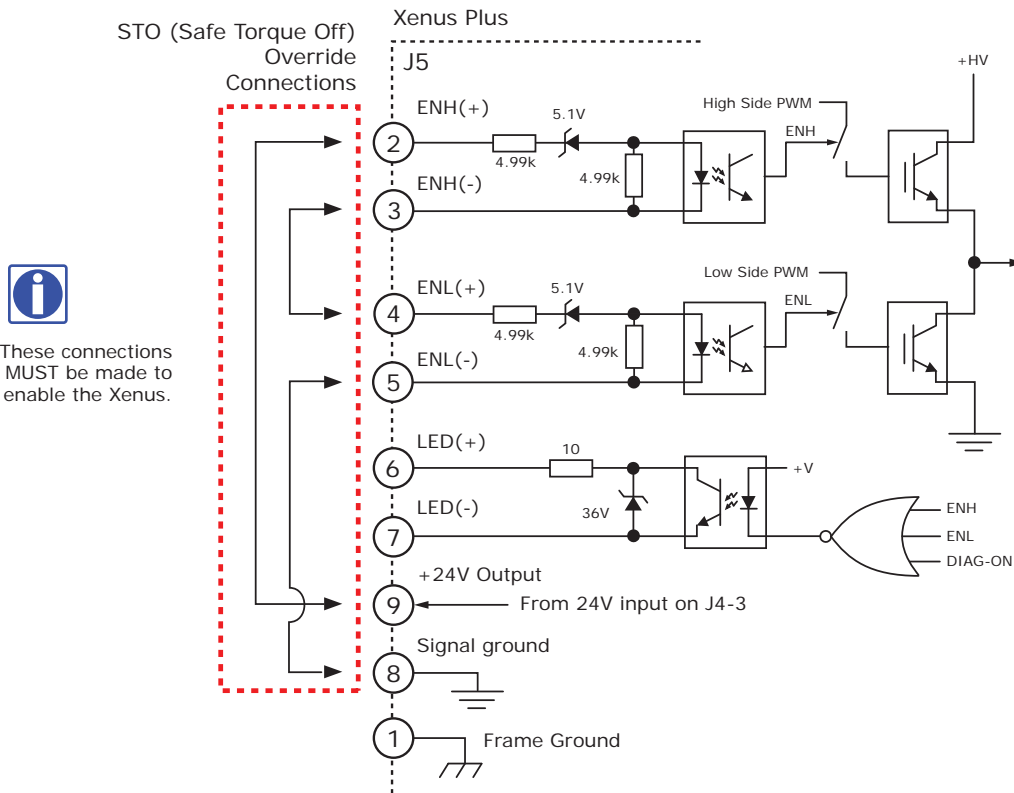

These connections MUST be made to enable the Xenus.

STO CONNECTOR

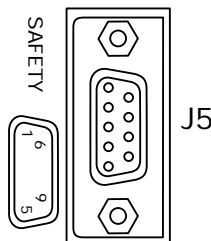

J5 SIGNALS

PIN	SIGNAL	PIN	SIGNAL
1	Frame Gnd	6	Enable LED(+)
2	Safe Enable HI(+)	7	Enable LED(-)
3	Safe Enable HI(-)	8	24 Vdc Common
4	Safe Enable LO(+)	9	+24 Vdc Input
5	Safe Enable LO(-)		

COMMAND INPUTS

DIGITAL POSITION

Digital position commands can be in either single-ended or differential format. Single-ended signals should be sourced from devices with active pull-up and pull-down to take advantage of the high-speed inputs. Differential inputs have 121 Ω line-terminators.

SINGLE-ENDED PULSE & DIRECTION

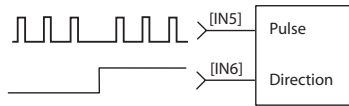

DIFFERENTIAL PULSE & DIRECTION

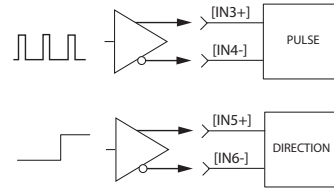

SINGLE-ENDED CU/CD

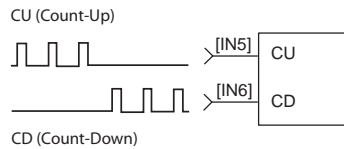

DIFFERENTIAL CU/CD

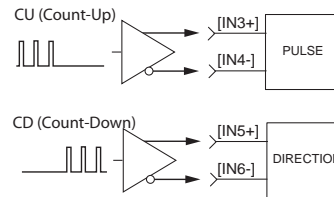

QUAD A/B ENCODER SINGLE-ENDED

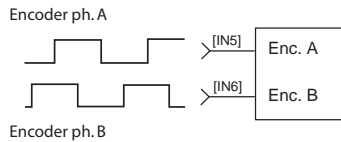

QUAD A/B ENCODER DIFFERENTIAL

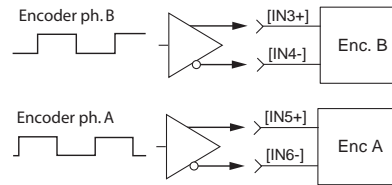

DIGITAL TORQUE, VELOCITY

Digital torque or velocity commands can be in either single-ended or differential format. Single-ended signals must be sourced from devices with active pull-up and pull-down to take advantage of the high-speed inputs.

SINGLE-ENDED PWM & DIRECTION

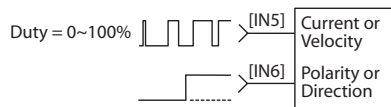

DIFFERENTIAL PWM & DIRECTION

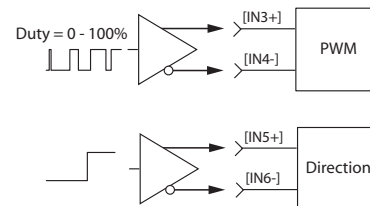

SINGLE-ENDED 50% PWM

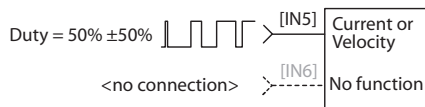

DIFFERENTIAL 50% PWM

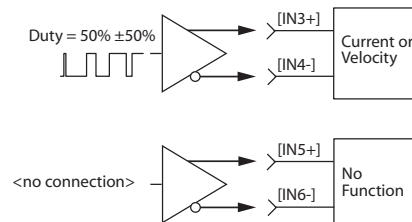

MULTI-MODE ENCODER PORT

This port consists of three differential input/output channels that take their functions from the Basic Setup of the drive. With quad A/B encoder feedback, the port works as an output, buffering the signals from the encoder. With resolver or sin/cos encoder versions, the feedback is converted to "emulated" quad A/B/X signals with programmable resolution. These signals can then be fed back to an external motion controller that closes the position or velocity loops. As an input, the port can take quad A/B signals to produce a dual-loop position control system or use the signals as master-encoder commands in camming mode. In addition, the port can take stepper command signals (CU/CD or Pulse/Direction) in differential format.

AS COMMAND INPUTS

AS DIGITAL COMMAND INPUTS IN PULSE/DIRECTION, PULSE-UP/PULSE-DOWN, OR DIGITAL QUADRATURE ENCODER FORMAT

The multi-mode port can also be used when digital command signals are in a differential format. These are the signals that typically go to single-ended inputs. But, at higher frequencies these are likely to be differential signals in which case the multi-mode port can be used.

AS A MASTER OR CAMMING ENCODER INPUT FROM A DIGITAL QUADRATURE ENCODER

When operating in position mode the multi-mode port can accept digital command signals from external encoders. These can be used to drive cam tables, or as master-encoder signals when operating in a master/slave configuration.

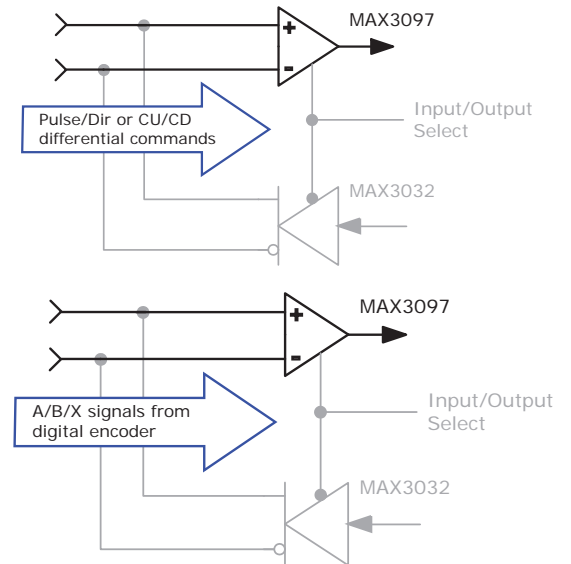

AS AN OUTPUT FOR FEEDBACK SIGNALS TO AN EXTERNAL CONTROLLER

AS BUFFERED OUTPUTS FROM A DIGITAL QUADRATURE PRIMARY ENCODER

When using a digital quadrature feedback encoder, the A/B/X signals drive the multi-mode port output buffers directly. This is useful in systems that use external controllers that also need the motor feedback encoder signals because these now come from J8, the Control connector. In addition to eliminating "Y" cabling where the motor feedback cable has to split to connect to both controller and motor, the buffered outputs reduce loading on the feedback cable that could occur if the motor encoder had to drive two differential inputs in parallel, each with it's own 121 ohm terminating resistor.

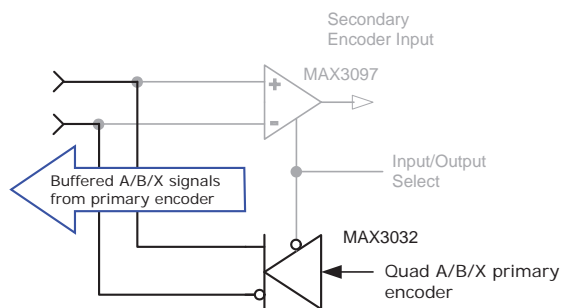

AS EMULATED QUAD A/B/X ENCODER OUTPUTS FROM AN ANALOG SIN/COS FEEDBACK ENCODER

Analog sin/cos signals are interpolated in the drive with programmable resolution. The incremental position data is then converted back into digital quadrature format which drives the multi-mode port output buffers. Some analog encoders also produce a digital index pulse which is connected directly to the port's output buffer. The result is digital quadrature A/B/X signals that can be used as feedback to an external control system.

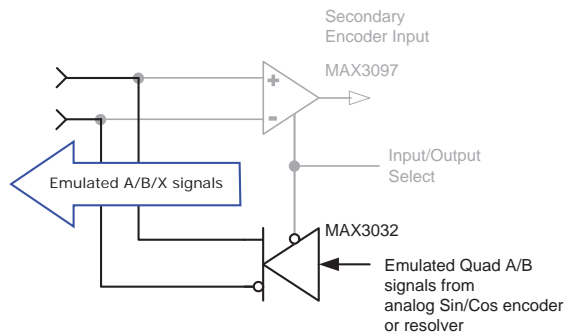

COMMAND INPUTS

NON-ISOLATED DIGITAL INPUTS

Inputs [IN1~2] are 24V tolerant
 These are high-speed types with pull-up resistors to +5 Vdc and 1 μ s RC filters when driven by active sources. The active level is programmable on each input. Input [IN1] is dedicated to the drive enable function. The remaining inputs [IN2~IN14] have programmable functions.

HS Inputs [IN1~2]
 24 Vdc max

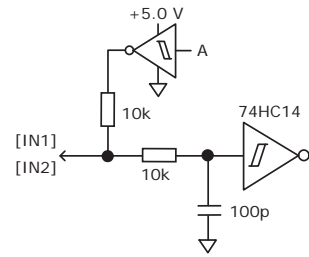

DIGITAL INPUTS [IN3~6]

These inputs have all the programmable functions of the GP inputs plus these additional functions on [IN8] & [IN9] which can be configured as single-ended or differential:

- PWM 50%, PWM & Direction for Velocity or Current modes
- Pulse/Direction, CU/CD, or A/B Quad encoder inputs for Position or Camming modes

SINGLE-ENDED
 12 Vdc max

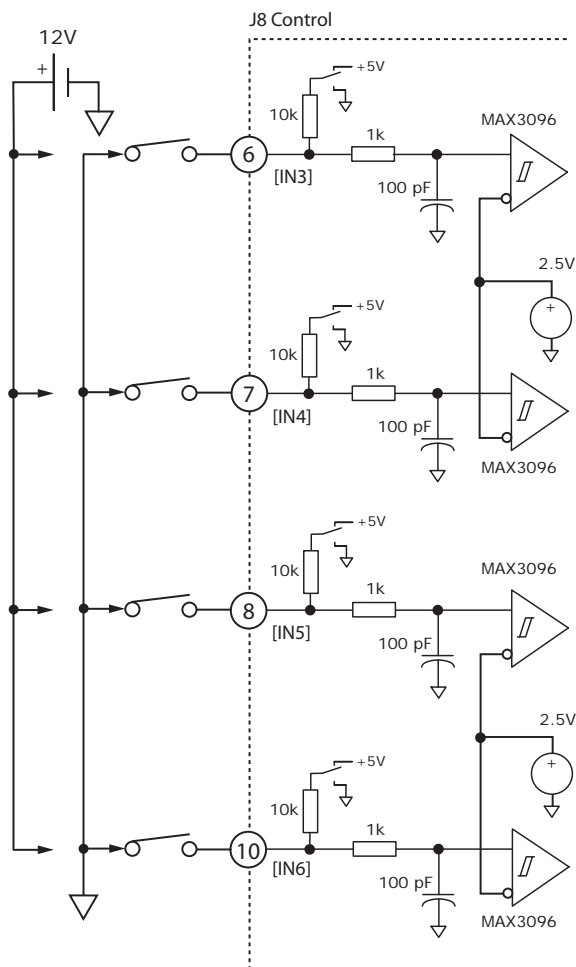

DIFFERENTIAL
 12 Vdc max

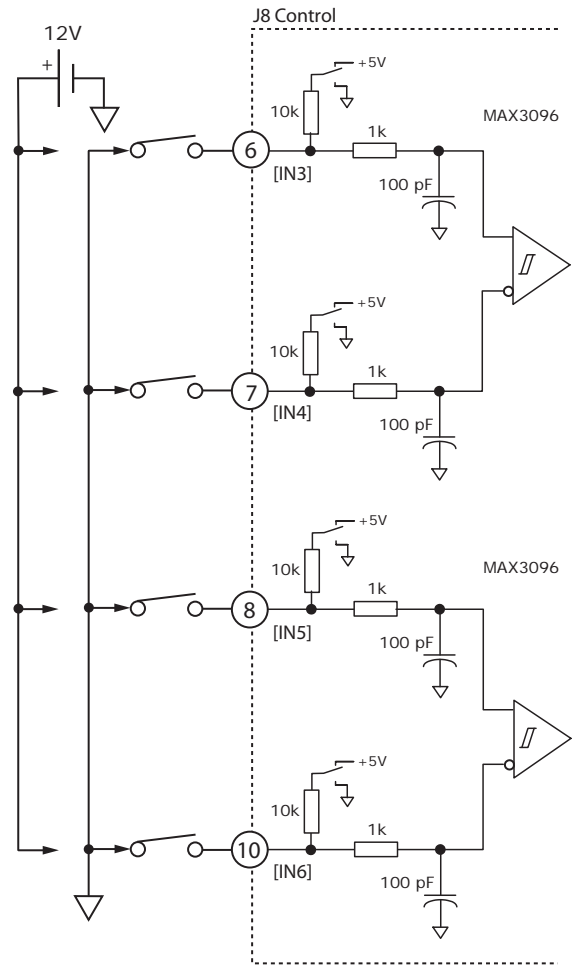

PLC outputs are frequently current-sourcing from 24V for driving grounded loads. PC based digital controllers commonly use NPN or current-sinking outputs. Set the Xenus inputs to pull-down to ground for current-sourcing connections, and to pull-up to 5V for current-sinking connections.

OPTO-ISOLATED DIGITAL INPUTS

These inputs have all the programmable functions of the GP inputs plus opto-isolation. There are two groups of four inputs, each with its' own common terminal. Grounding the common terminal configures the inputs to work with current-sourcing outputs from controllers like PLC's. When the common terminal is connected to +24V, then the inputs will be activated by current-sinking devices such as NPN transistors or N-channel MOSFETs. The minimum ON threshold of the inputs is ± 15 Vdc.

[IN7~10]
 ± 30 Vdc max

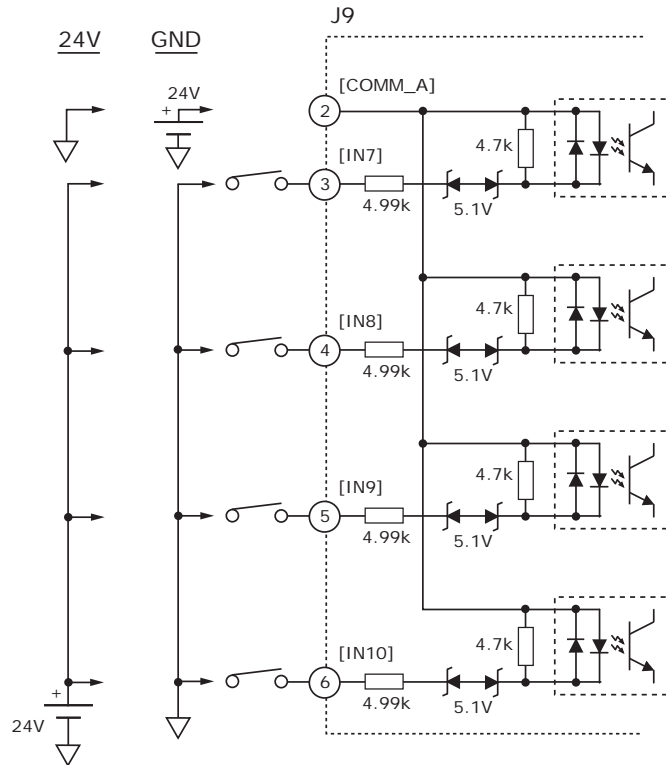

[IN11~14]
 ± 30 Vdc max

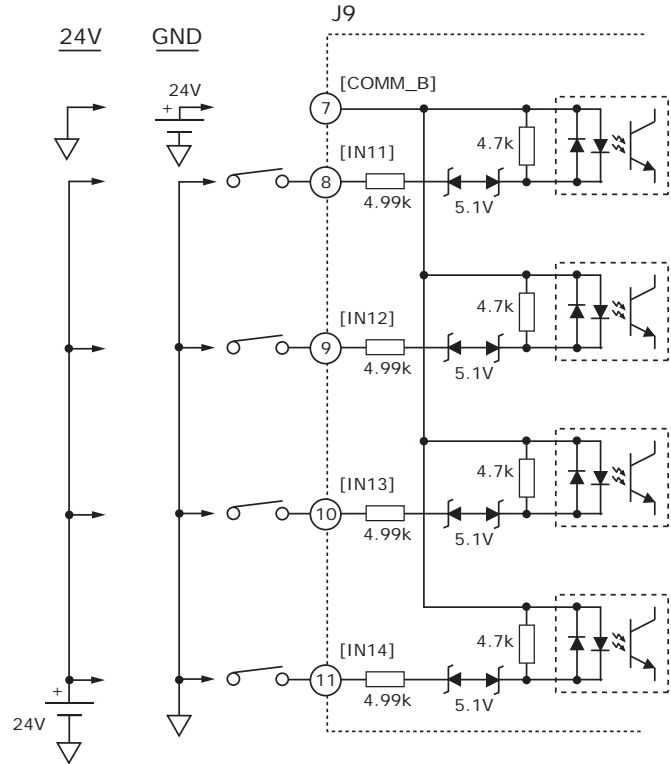

Inputs [7~14] work with current-sourcing OR current-sinking connections. Connect the COMM to controller ground/common for current-sourcing connections and to 5~24V from the controller for current-sinking connections.

ANALOG INPUTS

Two differential analog inputs with ± 10 Vdc range have programmable functions. As a reference input [AIN1] can take position/velocity/torque commands from a controller. A second input [AIN2] is programmable for other functions. The ratio of drive output current or velocity vs. reference input voltage is programmable.

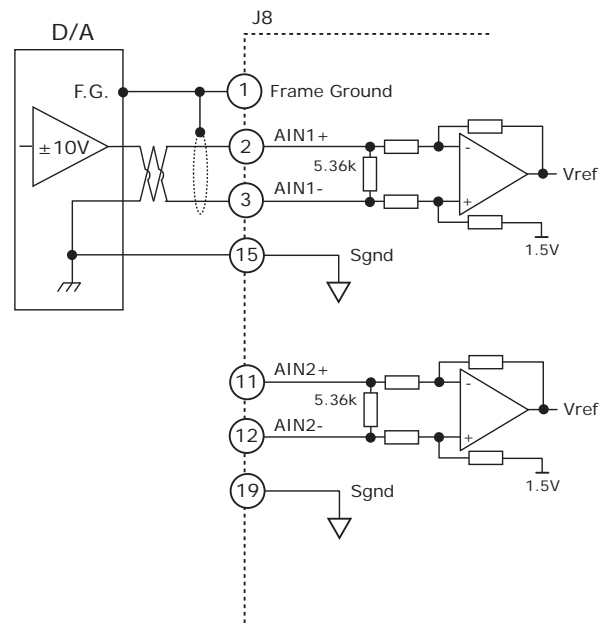

OUTPUTS

DIGITAL OUTPUTS [OUT1], [OUT2]

These are open-drain MOSFETs with 1 kΩ pull-up resistors in series with a diode to +5 Vdc. They can sink up to 1 A dc from external loads operating from power supplies to +30 Vdc. The output functions are programmable. The active state of the outputs is programmable to be on or off. When driving inductive loads such as a relay, an external fly-back diode is required.

The internal diode in the output is for driving PLC inputs that are opto-isolated and connected to +24 Vdc. The diode prevents conduction from +24 Vdc through the 1 kΩ resistor to +5 Vdc in the drive. This could turn the PLC input on, giving a false indication of the drive output state.

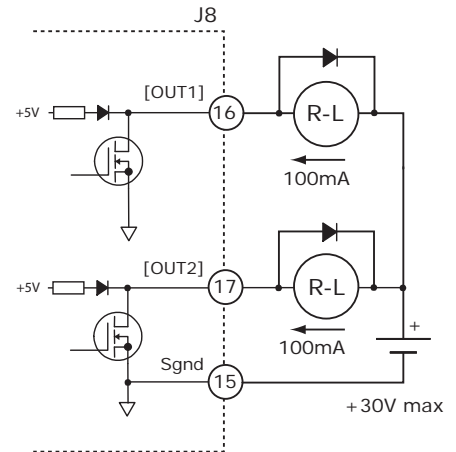

HIGH SPEED OUTPUT [OUT3]
5V CMOS

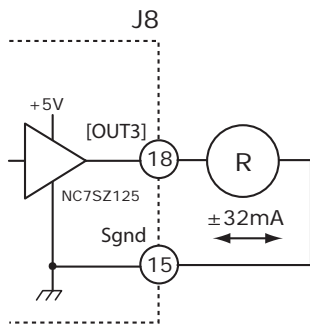

BRAKE OUTPUT [OUT6]

This output is an open-drain MOSFET with an internal flyback diode connected to the +24 Vdc input. It can sink up to 1A from a motor brake connected to the +24 Vdc supply. The operation of the brake is programmable with CME 2. It can also be programmed as a general-purpose digital output.

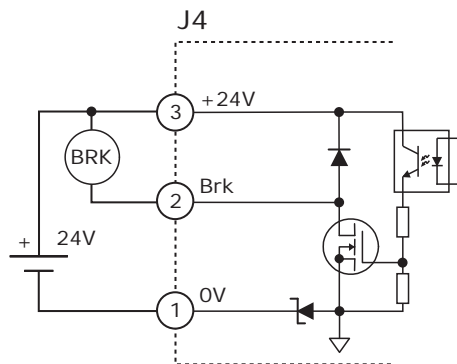

OPTO-ISOLATED OUTPUTS [OUT4,5]

30 Vdc max

Zener clamping diodes across outputs allow driving of resistive-inductive (R-L) loads without external flyback diodes.

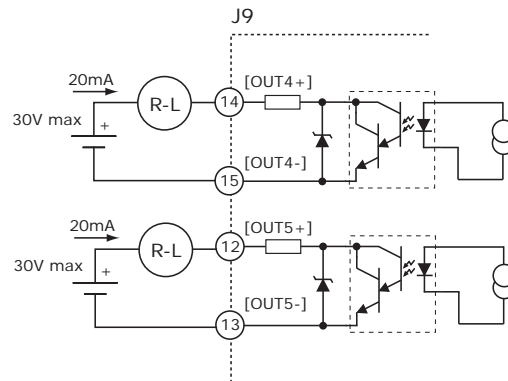

ANALOG OUTPUT

The analog output is programmable and has an output voltage range of ±5 Vdc. An op-amp buffers the output of a 12-bit D/A converter.

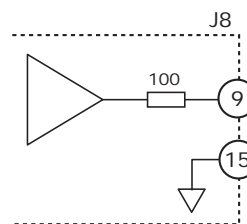

MOTOR CONNECTIONS

Motor connections are of three types: phase, feedback, and thermal sensor. The phase connections carry the drive output currents that drive the motor to produce motion. A thermal sensor that indicates motor overtemperature is used to shut down the drive to protect the motor. Feedback can be digital quad A/B encoder, analog sin/cos encoder, resolver or digital Halls, depending on the version of the drive.

QUAD A/B ENCODER WITH FAULT PROTECTION

Encoders with differential line-driver outputs provide incremental position feedback via the A/B signals and the optional index signal (X) gives a once per revolution position mark. The MAX3097 receiver has differential inputs with fault protections for the following conditions:

Short-circuits line-line: This produces a near-zero voltage between A & /A which is below the differential fault threshold.

Open-circuit condition: The 121Ω terminator resistor will pull the inputs together if either side (or both) is open. This will produce the same fault condition as a short-circuit across the inputs.

Low differential voltage detection: This is possible with very long cable runs and a fault will occur if the differential input voltage is < 200mV.

±15kV ESD protection: The 3097E has protection against high-voltage discharges using the Human Body Model.

Extended common-mode range: A fault occurs if the input common-mode voltage is outside of the range of -10V to +13.2V

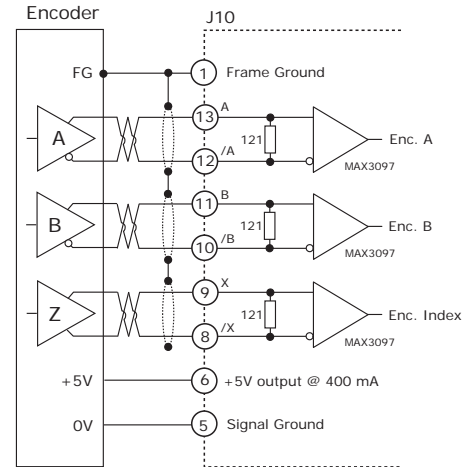

ANALOG SIN/COS INCREMENTAL ENCODER

The sin/cos/index inputs are differential with 121 Ω terminating resistors and accept 1 Vp-p signals in the format used by incremental encoders with analog outputs, or with ServoTube motors.

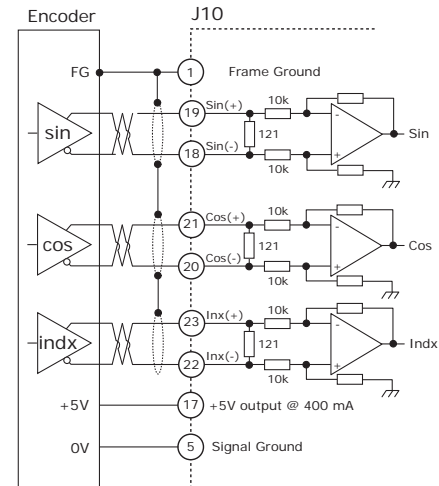

RESOLVER (-R MODELS)

Connections to the resolver should be made with shielded cable that uses three twisted-pairs. Once connected, resolver set up, motor phasing, and other commissioning adjustments are made with CME 2 software. There are no hardware adjustments.

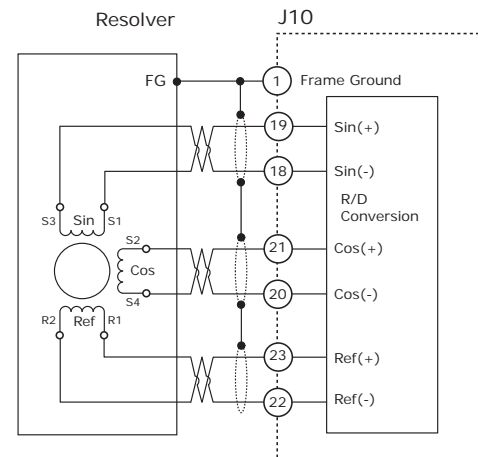

MOTOR CONNECTIONS (CONT'D)

SSI ABSOLUTE ENCODER

The SSI (Synchronous Serial Interface) is an interface used to connect an absolute position encoder to a motion controller or control system. The XEL drive provides a train of clock signals in differential format to the encoder which initiates the transmission of the position data on the subsequent clock pulses. The polling of the encoder data occurs at the current loop frequency (16 kHz). The number of encoder data bits and counts per motor revolution are programmable. The hardware bus consists of two signals: SCLK and SDATA. Data is sent in 8 bit bytes, LSB first. The SCLK signal is only active during transfers. Data is clocked out on the falling edge and clock in on the rising edge of the Master.

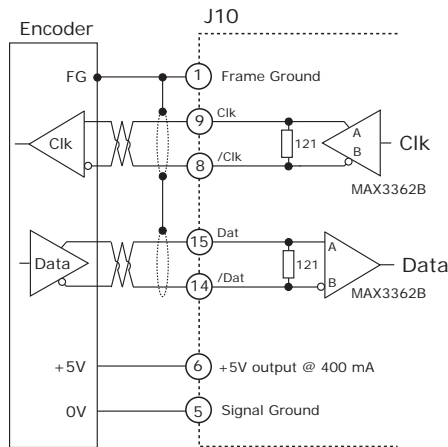

BISS ABSOLUTE ENCODER

BiSS is an - Open Source - digital interface for sensors and actuators. BiSS refers to principles of well known industrial standards for Serial Synchronous Interfaces like SSI, AS-Interface® and Interbus® with additional options.

- Serial Synchronous Data Communication
- Cyclic at high speed
- 2 unidirectional lines Clock and Data
- Line delay compensation for high speed data transfer
- Request for data generation at slaves
- Safety capable: CRC, Errors, Warnings
- Bus capability incl. actuators
- Bidirectional
- BiSS B-protocol: Mode choice at each cycle start
- BiSS C-protocol: Continuous mode

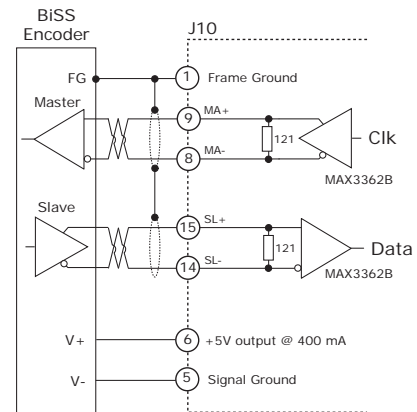

ENDAT ABSOLUTE ENCODER

The EnDat interface is a Heidenhain interface that is similar to SSI in the use of clock and data signals, but which also supports analog sin/cos channels from the same encoder. The number of position data bits is programmable as is the use of sin/cos incremental signals is optional in the EnDat specification.

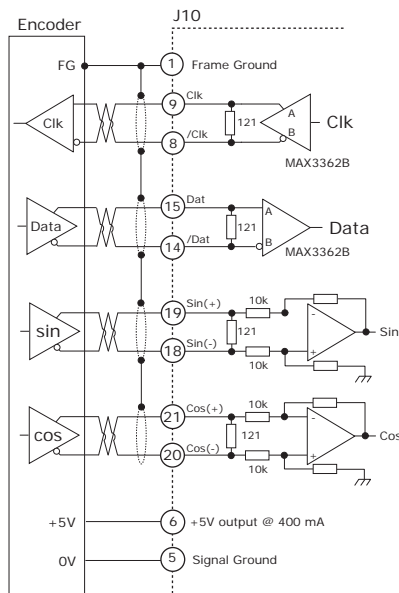

NIKON-A ABSOLUTE ENCODER

The Nikon A interface is a serial, half-duplex type that is electrically the same as RS-485

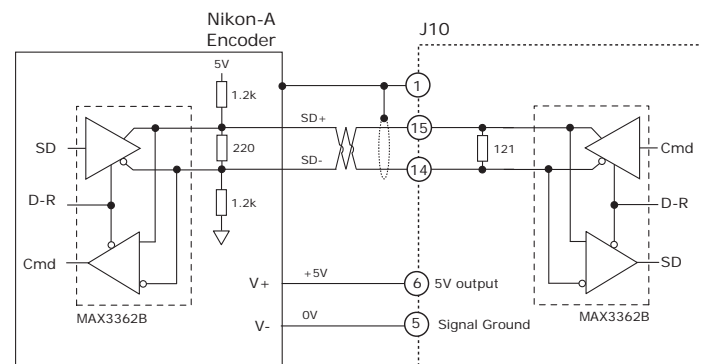

MOTOR CONNECTIONS (CONT'D)

MOTOR PHASE CONNECTIONS

The drive output is a three-phase PWM inverter that converts the DC buss voltage (+HV) into three sinusoidal voltage waveforms that drive the motor phase-coils. Cable should be sized for the continuous current rating of the motor. Motor cabling should use twisted, shielded conductors for CE compliance, and to minimize PWM noise coupling into other circuits. The motor cable shield should connect to motor frame and the drive frame ground terminal (J2-1) for best results.

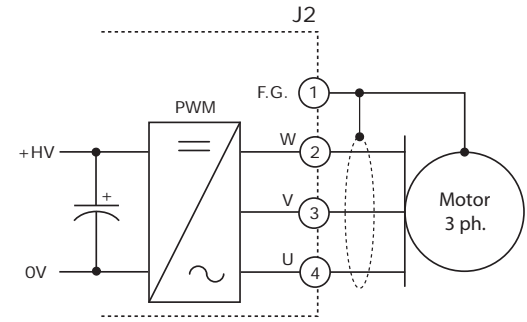

DIGITAL HALL SIGNALS

Hall signals are single-ended signals that provide absolute feedback within one electrical cycle of the motor. There are three of them (U, V, & W) and they may be sourced by magnetic sensors in the motor, or by encoders that have Hall tracks as part of the encoder disc. They typically operate at much lower frequencies than the motor encoder signals, and are used for commutation-initialization after startup, and for checking the motor phasing after the amplifier has switched to sinusoidal commutation.

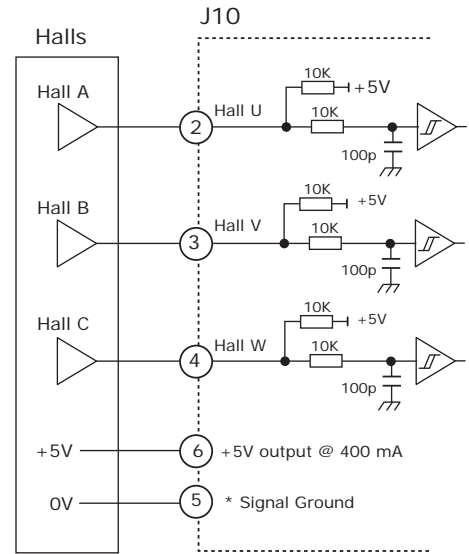

* Alternate Sgnd connections on J10 are pins 16, 25, 26

MOTOR TEMPERATURE SENSOR

Analog input [AIN3] Motemp, is for use with a motor overtemperature switch or sensor. The input voltage goes through a low-pass filter to a 12-bit A/D converter. The active level of the input, Vset, is programmable generate an over-temperature fault if the input voltage is <Vset, or >Vset.

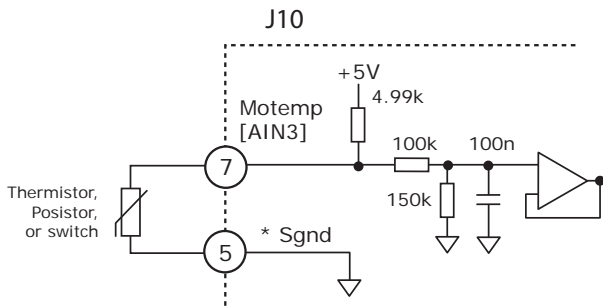

* Alternate Sgnd connections on J10 are pins 16, 25, 26

ENCODER FAULT

A high-speed (HS) non-isolated input with a pull-up resistor to +5 Vdc and 1 μs RC filter when driven by active sources. The active level is programmable. For encoders that output a FAULT signal in addition to the other position data signals

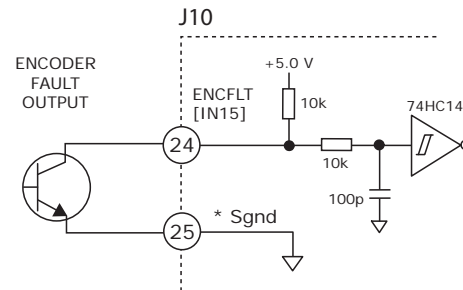

MOTOR CONNECTIONS (CONT'D)

MULTI-MODE ENCODER PORT

This port consists of three differential input/output channels that take their functions from the Basic Setup of the drive. With quad A/B encoder feedback, the port works as an output, buffering the signals from the encoder. With resolver or sin/cos encoder versions, the feedback is converted to "emulated" quad A/B/X signals with programmable resolution. These signals can then be fed back to an external motion controller that closes the position or velocity loops. As an input, the port can take quad A/B signals to produce a dual-loop position control system or use the signals as master-encoder commands in camming mode. In addition, the port can take stepper command signals (CU/CD or Pulse/Direction) in differential format.

AS BUFFERED OUTPUTS FROM A DIGITAL QUADRATURE PRIMARY ENCODER

When using a digital quadrature feedback encoder, the A/B/X signals drive the multi-mode port output buffers directly. This is useful in systems that use external controllers that also need the motor feedback encoder signals because these now come from J8, the Control connector. In addition to eliminating "Y" cabling where the motor feedback cable has to split to connect to both controller and motor, the buffered outputs reduce loading on the feedback cable that could occur if the motor encoder had to drive two differential inputs in parallel, each with it's own 121 ohm terminating resistor.

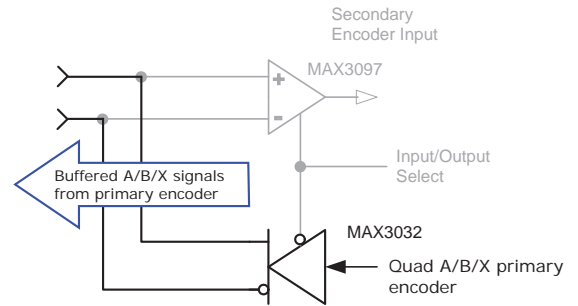

AS EMULATED QUAD A/B/X ENCODER OUTPUTS FROM AN ANALOG SIN/COS FEEDBACK ENCODER

Analog sin/cos signals are interpolated in the drive with programmable resolution. The incremental position data is then converted back into digital quadrature format which drives the multi-mode port output buffers. Some analog encoders also produce a digital index pulse which is connected directly to the port's output buffer. The result is digital quadrature A/B/X signals that can be used as feedback to an external control system.

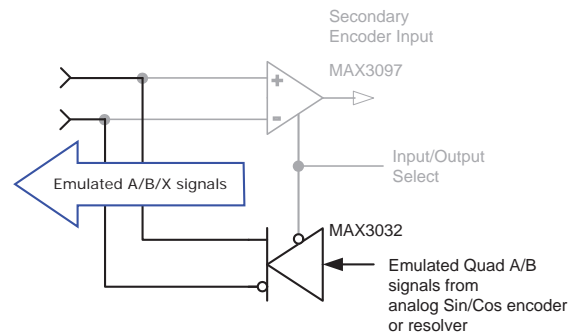

AS A MASTER OR CAMMING ENCODER INPUT FROM A DIGITAL QUADRATURE ENCODER

When operating in position mode the multi-mode port can accept digital command signals from external encoders. These can be used to drive cam tables, or as master-encoder signals when operating in a master/slave configuration.

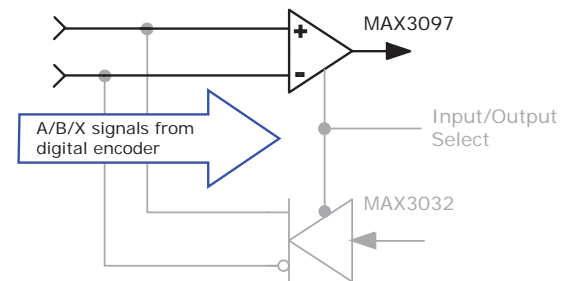

AS DIGITAL COMMAND INPUTS IN PULSE/DIRECTION, PULSE-UP/PULSE-DOWN, OR DIGITAL QUADRATURE ENCODER FORMAT

The multi-mode port can also be used when digital command signals are in a differential format. These are the signals that typically go to single-ended inputs. But, at higher frequencies these are likely to be differential signals in which case the multi-mode port can be used.

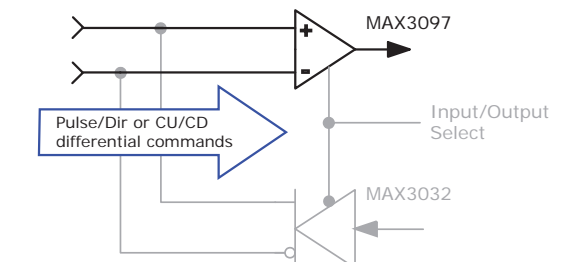

MOTOR CONNECTIONS (CONT'D)

CE = Shielded cables required for CE compliance

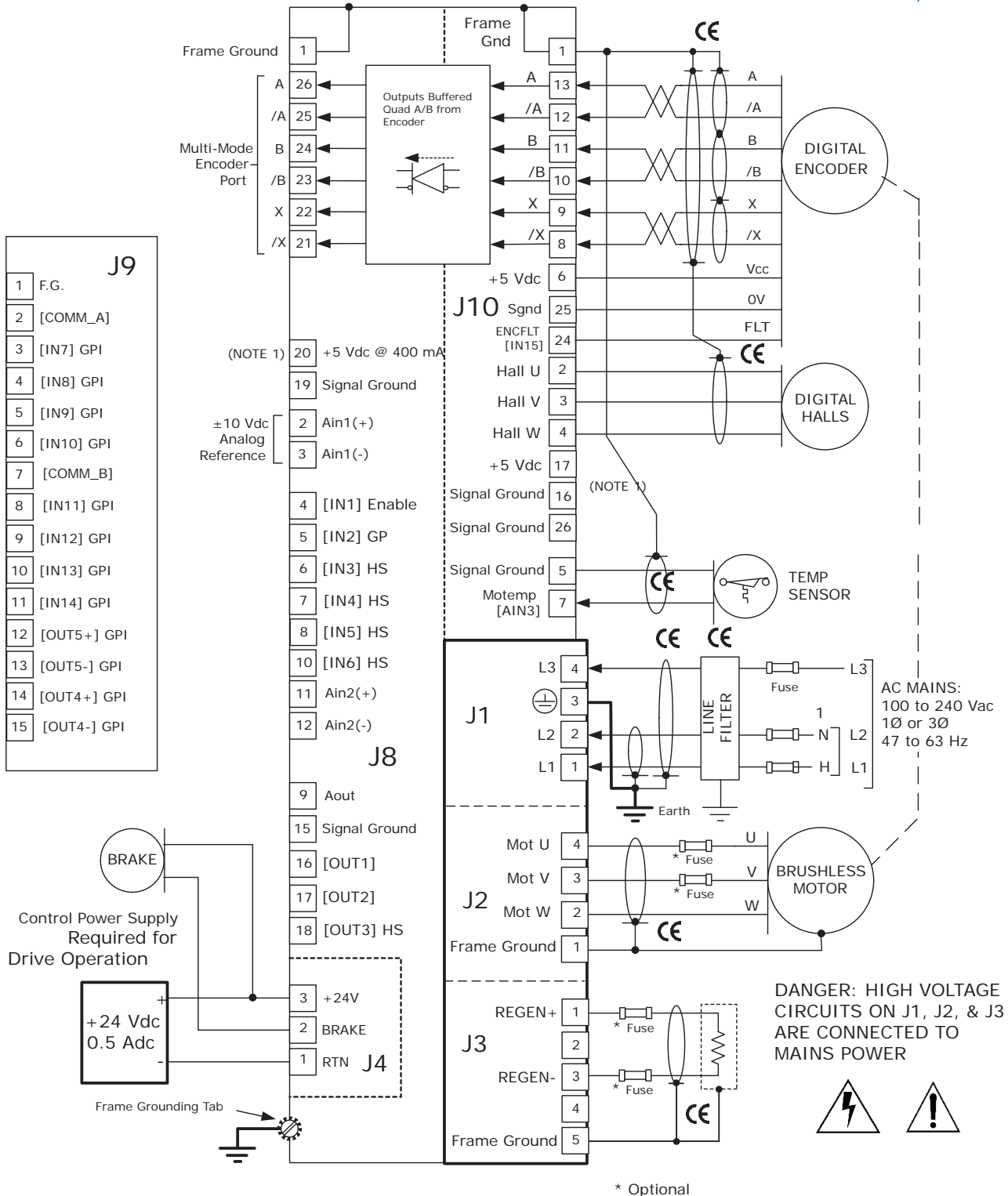

MOTOR CONNECTIONS (CONT'D)

CE = Shielded cables required for CE compliance

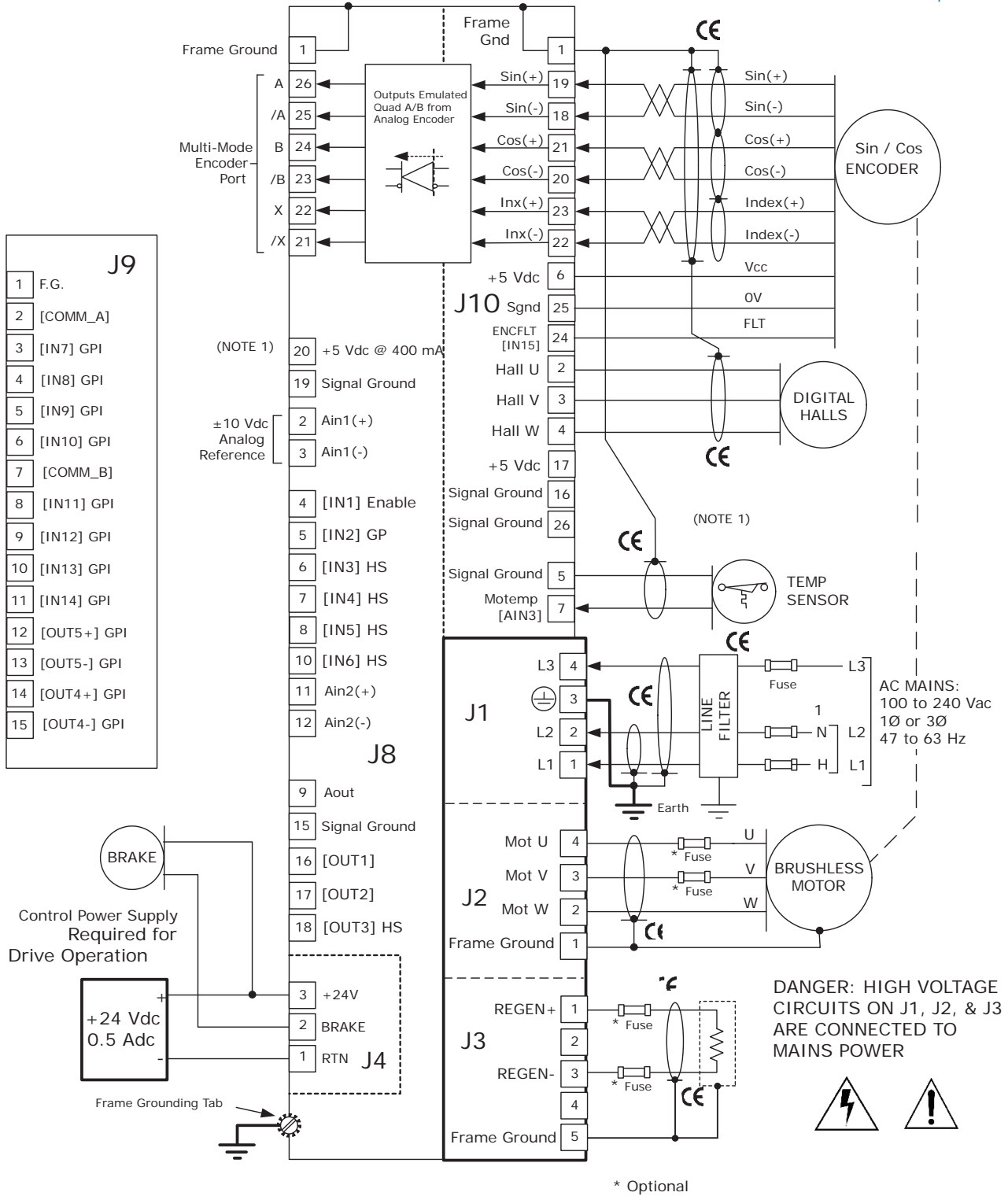

NOTES:

- 1) The total output current from the +5 Vdc supply to J7-20 cannot exceed 400 mAdc
- 2) Line filter is required for CE

MOTOR CONNECTIONS (CONT'D)

CE = Shielded cables required for CE compliance

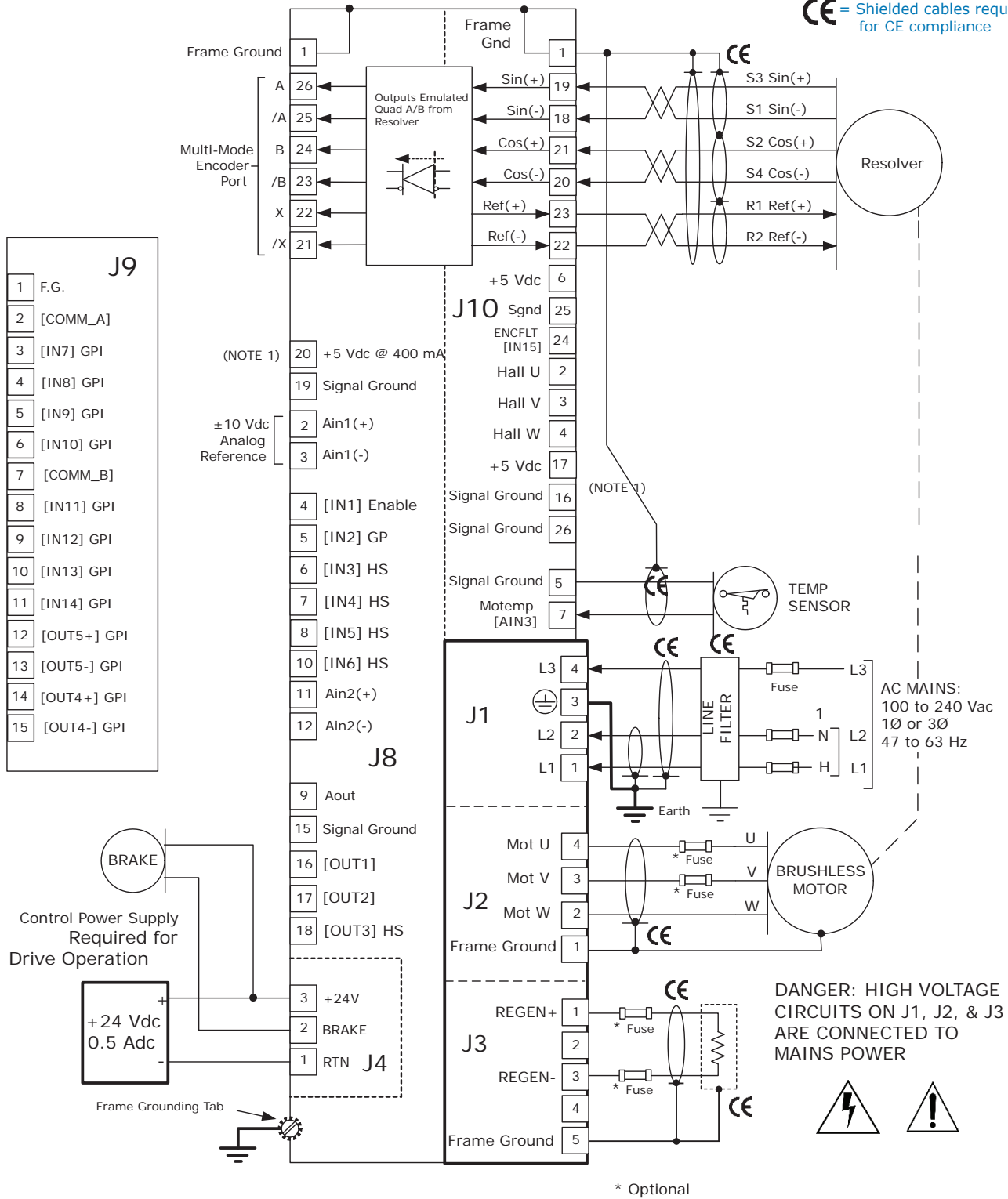



WARNING: Hazardous voltages exist on connections to J1, J2, & J3 when power is applied, and for up to 30 seconds after power is removed.



J1 CABLE CONNECTOR:

Wago: 51118287 or 721-204/026-045/RN01-0000
Euro-style 7,5 mm pluggable female terminal block with preceding ground receptacle
Cable: AWG 12, 600 V recommended for XEL-230-36-R and XEL-230-40-R models, AWG 14, 600V for XEL-230-18-R
Shielded cable required for CE compliance

J1 MAINS CONNECTIONS

Signal	Pin
Mains Input L3	4
Protective Ground	3
Mains Input L2	2
Mains Input L1	1

J2 CABLE CONNECTOR:

Wago: 51118008 or 721-104/026-047/RN01-0000
Euro-style 5,0 mm pluggable female terminal block
Cable: AWG 12, 600 V recommended for XEL-230-36-R and XEL-230-40-R models, AWG 14, 600V for XEL-230-18-R
Shielded cable required for CE compliance

J2 MOTOR OUTPUTS

Signal	Pin
Motor Phase U	4
Motor Phase V	3
Motor Phase W	2
Cable Shield	1

J3 CABLE CONNECTOR:

Wago: 51111279 or 721-605/000-044/RN01-0000
Euro-style 5,0 mm pluggable male terminal block
Cable: AWG 12, 600 V recommended for XEL-230-36-R and XEL-230-40-R models, AWG 14, 600V for XEL-230-18-R
Shielded cable required for CE compliance

J3 REGEN RESISTOR

Signal	Pin
Regen Resistor	1
No Connection	2
Regen Resistor	3
No Connection	4
Cable Shield	5

WIRE INSERTION/EXTRACTION TOOL:

Used on J1, J2, J3, & J4
Wago 231-131

ISOLATED CIRCUIT

NOTE: AN EXTERNAL +24 VDC POWER SUPPLY IS REQUIRED FOR OPERATION

J4 CABLE CONNECTOR:

Wago: 51117974 or 721-103/026-047/RN01-0000
Euro-style 5,0 mm pluggable terminal block

J4 +24 VDC & BRAKE

Signal	Pin
+24 Vdc Control Power	3
Brake Output [OUT6]	2
0V (+24 Vdc Return)	1

ISOLATED CIRCUIT

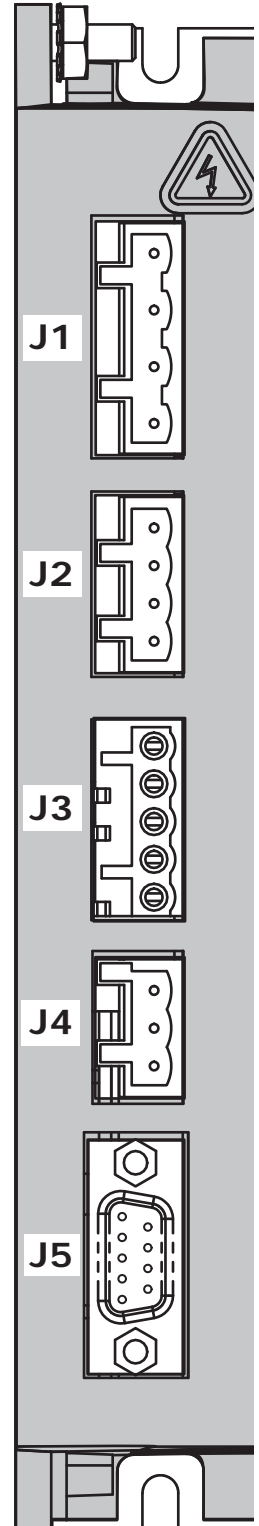

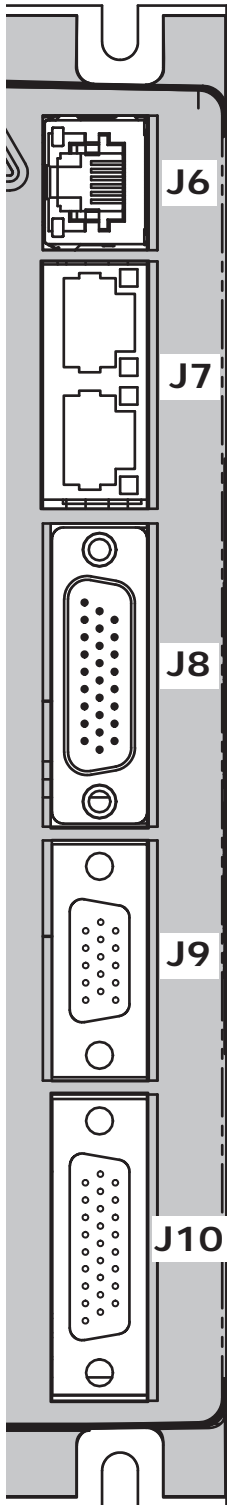

J8 CONTROL SIGNALS

PIN	SIGNAL	PIN	SIGNAL	PIN	SIGNAL
9	[AOUT]	18	[OUT3] HS	26	Multi Enc A2
8	[IN5] HS	17	[OUT2]	25	Multi Enc /A2
7	[IN4] HS	16	[OUT1]	24	Multi Enc B2
6	[IN3] HS	15	Signal Gnd	23	Multi Enc /B2
5	[IN2] GP	14	Multi Enc S2	22	Multi Enc X2
4	[IN1] GP	13	Multi Enc /S2	21	Multi Enc /X2
3	[AIN1-]	12	[AIN2-]	20	+5 Vdc Out
2	[AIN1+]	11	[AIN2+]	19	Signal Gnd
1	Frame Gnd	10	[IN6] HS		

J8 CABLE CONNECTOR:

High-Density D-Sub female, 26 Position

J9 SECONDARY I/O CONNECTOR

PIN	SIGNAL	PIN	SIGNAL	PIN	SIGNAL
1	Frame Gnd	6	[IN10] GPI	11	[IN14] GPI
2	[COMM_A]	7	[COMM_B]	12	[OUT5+] GPI
3	[IN7] GPI	8	[IN11] GPI	13	[OUT5-] GPI
4	[IN8] GPI	9	[IN12] GPI	14	[OUT4+] GPI
5	[IN9] GPI	10	[IN13] GPI	15	[OUT4-] GPI

J9 CABLE CONNECTOR:

High-Density D-Sub male, 15 Position

J10 FEEDBACK

PIN	SIGNAL	PIN	SIGNAL	PIN	SIGNAL
1	Frame Gnd	10	Enc /B1	19	Sin1(+)
2	Hall U	11	Enc B1	20	Cos1(-)
3	Hall V	12	Enc /A1	21	Cos1(+)
4	Hall W	13	Enc A1	22	Index1(-)
5	Signal Gnd	14	Enc /S1	23	Index1(+)
6	+5 Vdc Out	15	Enc S1	24	[IN15] ENCFLT
7	[AIN3] Motemp	16	Signal Gnd	25	Signal Gnd
8	Enc /X1	17	+5 Vdc Out	26	Signal Gnd
9	Enc X1	18	Sin1(-)		

J10 CABLE CONNECTOR:

High-Density D-Sub male, 26 Position

J5 SAFETY DISABLE

PIN	SIGNAL	PIN	SIGNAL
1	Frame Gnd	6	Enable LED(+)
2	Safe Enable HI(+)	7	Enable LED(-)
3	Safe Enable HI(-)	8	24 Vdc Common
4	Safe Enable LO(+)	9	+24 Vdc Output
5	Safe Enable LO(-)		

J5 CABLE CONNECTOR:

D-Sub male, 9 Position



WARNING: Hazardous voltages exist on connections to J1, J2, & J3 when power is applied, and for up to 30 seconds after power is removed.



J1 CABLE CONNECTOR:

Wago: 51118287 or 721-204/026-045/RN01-0000
Euro-style 7,5 mm pluggable female terminal block with preceding ground receptacle
Cable: AWG 12, 600 V recommended for XEL-230-36-R and XEL-230-40-R models, AWG 14, 600V for XEL-230-18-R
Shielded cable required for CE compliance

J1 MAINS CONNECTIONS

Signal	Pin
Mains Input L3	4
Protective Ground	3
Mains Input L2	2
Mains Input L1	1

J2 CABLE CONNECTOR:

Wago: 51118008 or 721-104/026-047/RN01-0000
Euro-style 5,0 mm pluggable female terminal block
Cable: AWG 12, 600 V recommended for XEL-230-36-R and XEL-230-40-R models, AWG 14, 600V for XEL-230-18-R
Shielded cable required for CE compliance

J2 MOTOR OUTPUTS

Signal	Pin
Motor Phase U	4
Motor Phase V	3
Motor Phase W	2
Cable Shield	1

J3 CABLE CONNECTOR:

Wago: 51111279 or 721-605/000-044/RN01-0000
Euro-style 5,0 mm pluggable male terminal block
Cable: AWG 12, 600 V recommended for XEL-230-36-R and XEL-230-40-R models, AWG 14, 600V for XEL-230-18-R
Shielded cable required for CE compliance

J3 REGEN RESISTOR

Signal	Pin
Regen Resistor	1
No Connection	2
Regen Resistor	3
No Connection	4
Cable Shield	5

WIRE INSERTION/EXTRACTION TOOL:

Used on J1, J2, J3, & J4
Wago 231-131

ISOLATED CIRCUIT

NOTE: AN EXTERNAL +24 VDC POWER SUPPLY IS REQUIRED FOR OPERATION

J4 CABLE CONNECTOR:

Wago: 51117974 or 721-103/026-047/RN01-0000
Euro-style 5,0 mm pluggable terminal block

J4 +24 VDC & BRAKE

Signal	Pin
+24 Vdc Control Power	3
Brake Output [OUT6]	2
0V (+24 Vdc Return)	1

ISOLATED CIRCUIT

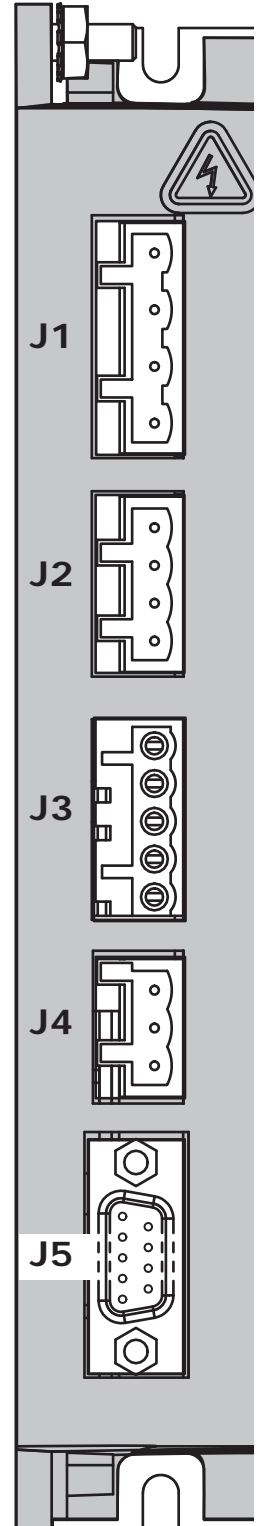

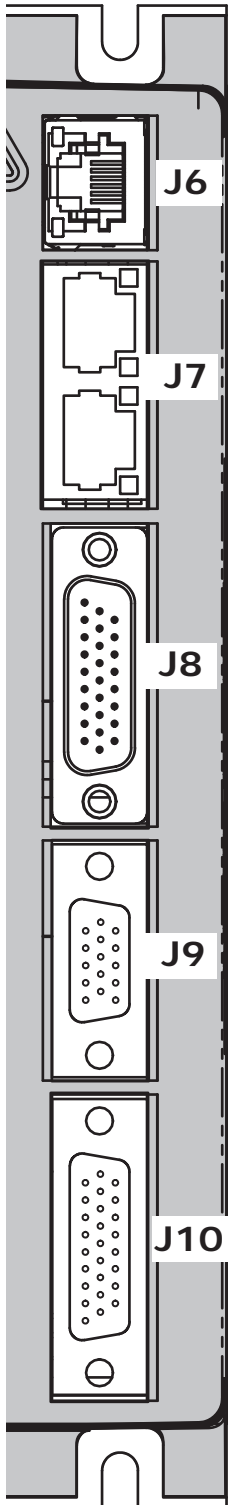

J8 CONTROL SIGNALS

PIN	SIGNAL	PIN	SIGNAL	PIN	SIGNAL
9	[AOUT]	18	[OUT3] HS	26	Multi Enc A2
8	[IN5] HS	17	[OUT2]	25	Multi Enc /A2
7	[IN4] HS	16	[OUT1]	24	Multi Enc B2
6	[IN3] HS	15	Signal Gnd	23	Multi Enc /B2
5	[IN2] GP	14	Multi Enc S2	22	Multi Enc X2
4	[IN1] GP	13	Multi Enc /S2	21	Multi Enc /X2
3	[AIN1-]	12	[AIN2-]	20	+5 Vdc Out
2	[AIN1+]	11	[AIN2+]	19	Signal Gnd
1	Frame Gnd	10	[IN6] HS		

J8 CABLE CONNECTOR:

High-Density D-Sub female, 26 Position

J9 SECONDARY I/O CONNECTOR

PIN	SIGNAL	PIN	SIGNAL	PIN	SIGNAL
1	Frame Gnd	6	[IN10] GPI	11	[IN14] GPI
2	[COMM_A]	7	[COMM_B]	12	[OUT5+] GPI
3	[IN7] GPI	8	[IN11] GPI	13	[OUT5-] GPI
4	[IN8] GPI	9	[IN12] GPI	14	[OUT4+] GPI
5	[IN9] GPI	10	[IN13] GPI	15	[OUT4-] GPI

J9 CABLE CONNECTOR:

High-Density D-Sub male, 15 Position

J10 FEEDBACK

PIN	SIGNAL	PIN	SIGNAL	PIN	SIGNAL
1	Frame Gnd	10	Enc /B1	19	Sin1(+) S3
2	Hall U	11	Enc B1	20	Cos1(-) S4
3	Hall V	12	Enc /A1	21	Cos1(+) S2
4	Hall W	13	Enc A1	22	Ref(-) R2
5	Signal Gnd	14	Enc /S1	23	Ref(+) R1
6	+5 Vdc Out	15	Enc S1	24	[IN15] ENCFLT
7	[AIN3] Motemp	16	Signal Gnd	25	Signal Gnd
8	Enc /X1	17	+5 Vdc Out	26	Signal Gnd
9	Enc X1	18	Sin1(-) S1		

J10 CABLE CONNECTOR:

High-Density D-Sub male, 26 Position

J5 SAFETY DISABLE

PIN	SIGNAL	PIN	SIGNAL
1	Frame Gnd	6	Enable LED(+)
2	Safe Enable HI(+)	7	Enable LED(-)
3	Safe Enable HI(-)	8	24 Vdc Common
4	Safe Enable LO(+)	9	+24 Vdc Output
5	Safe Enable LO(-)		

J5 CABLE CONNECTOR:

D-Sub male, 9 Position

DRIVE POWER SOURCES

An external +24 Vdc power supply is required, and powers an internal DC/DC converter that supplies all the control voltages for drive operation. Use of an external supply enables EtherCAT communication with the drive when the mains power has been removed. Power distribution in XEL is divided into three sections: +24 Vdc, signal, and high-voltage. Each is isolated from the other and all are isolated from the chassis.

EXTERNAL +24 VDC

The primary side of the DC/DC converter operates directly from the external +24 Vdc supply and is isolated from other drive power sections. The Brake output [OUT6] operates in this section and is referenced to the +24 Vdc return (0V). It sinks current from an external load connected to the external +24 Vdc power source.

INTERNAL SIGNAL POWER

The signal power section supplies power for the control circuits as well as logic inputs and outputs. Motor feedback signals such as Halls, encoder, and temperature sensor operate from this power source. All signal circuits are referenced to signal ground. This ground should connect to the control system circuit ground or common so that drive and controller inputs and output voltage levels work properly with each other.

MAINS POWER

Mains power drives the high-voltage section. It is rectified and capacitor-filtered to produce +HV which the PWM stage converts into voltages that drive either three phase brushless or DC brush motors. An internal solid-state switch together with an external power resistor provides dissipation during regeneration when the mechanical energy of the motor is converted back into electrical energy that must be dissipated before it charges the internal capacitors to an overvoltage condition. All the circuits in this section are "hot", that is, they connect directly to the mains and must be considered high-voltages and a shock hazard requiring proper insulation techniques during installation.

GROUNDING

A grounding system has three primary functions: safety, voltage-reference, and shielding. As a safety measure, the primary ground at J1-3 will carry fault-currents from the mains in the case of an internal failure or short-circuit of electronic components. Wiring to this is typically done with the green conductor with yellow stripe using the same gauge wire as that used for the mains. The pin on the drive at J1-3 is longer than the other pins on J1 giving it a first-make, last-break action so that the drive chassis is never ungrounded when the mains power is connected. This wire is a 'bonding' conductor that should connect to an earthed ground point and must not pass through any circuit interrupting devices.

All of the circuits on J1, J2, and J3 are mains-connected and must never be grounded. The ground terminals at J1-3, J2-1, and J3-5 all connect to the drive chassis and are isolated from all drive internal circuits.

Signal grounding references the drive control circuits to those of the control system. These controls circuits typically have their own earth connection at some point. To eliminate ground-loops it is recommended that the drive signal ground be connected to the control system circuit ground. When this is done the drive signal voltages will be referenced to the same 0 V level as the circuits in the control system. Small currents flow between controller and drive when inputs and outputs interact. The signal ground is the path for these currents to return to their power sources in both controller and drive.

Shields on cables reduce emissions from the drive for CE compliance and protect internal circuits from interference due to external sources of electrical noise. Because of their smaller wire gauge, these should not be used as part of a safety-ground system. Motor cases can be safety-grounded either at the motor, by earthing the frame, or by a grounding conductor in the motor cable that connects to J2-1. This cable should be of the same gauge as the other motor phase cables.

For CE compliance and operator safety, the drive heatplate should be earthed to the equipment frame. An unplated tab is provided on the heatplate (near to J1) for this connection.

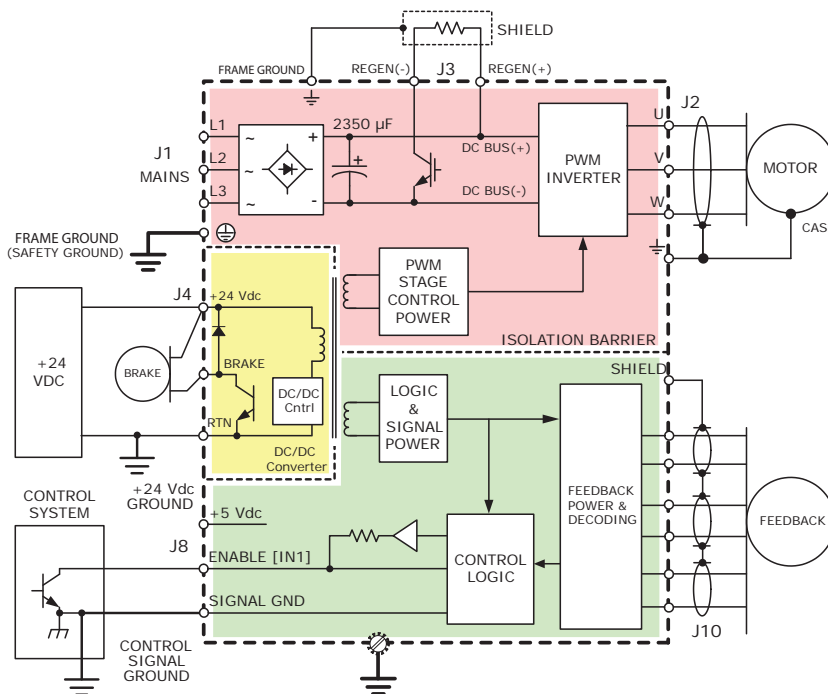

REGENERATION

The chart below shows the energy absorption in W·s for a Xenus Plus drive operating at some typical mains voltages. When the load mechanical energy is greater than these values an external regen resistor is available as an accessory.

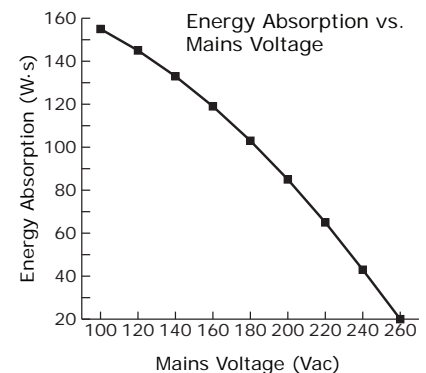

GROUNDING & SHIELDING FOR CE

Grounding and shielding are the means of controlling the emission of radio frequency energy from the drive so that it does not interfere with other electronic equipment. The use of shielded cables to connect the drive to motors and feedback devices is a way of extending the chassis of the drive out to these devices so that the conductors carrying noise generated by the drive are completely enclosed by a conductive shield.

The process begins at the mains connector of the drive, J1. The ground terminal here has a circle around it indicating that this is the safety or "bonding" ground connection. This should be connected with wire that is the same gauge as that used for the mains. In the case of a short-circuit in the drive the function of this ground connection is to carry the fault current to earth ground until the safety device (fuse or circuit breakers) disconnects the drive from the mains. This connection ensures that the heatplate of the drive remains at earth potential and eliminating a shock hazard that could occur of the chassis were allowed to float to the potential of the mains.

While this connection keeps the heatplate at earth potential the high frequency noise generated by switching circuits in the drive can radiate from the wire used for the safety ground connection. In order to keep the path between the heatplate and earth as short as possible it's also recommended to mount the drive to the equipment panel. An unplated tab on the heatplate is provided for this and will ground the heatplate directly to the equipment frame, further reducing emissions.

The heatplate also connects directly to the frame ground terminals on the motor, feedback, and regen connectors. Note that the ground symbols for these do not have a circle around them which indicates that these are for shielding and not for safety grounding. Motors and their feedback devices (which are typically in the motor case) should be grounded by mounting to equipment that is grounded as a safety ground. By connecting the shields for these devices at the drive and at the device, the connection is continuous and provides a return path for radio-frequency energy to the drive.

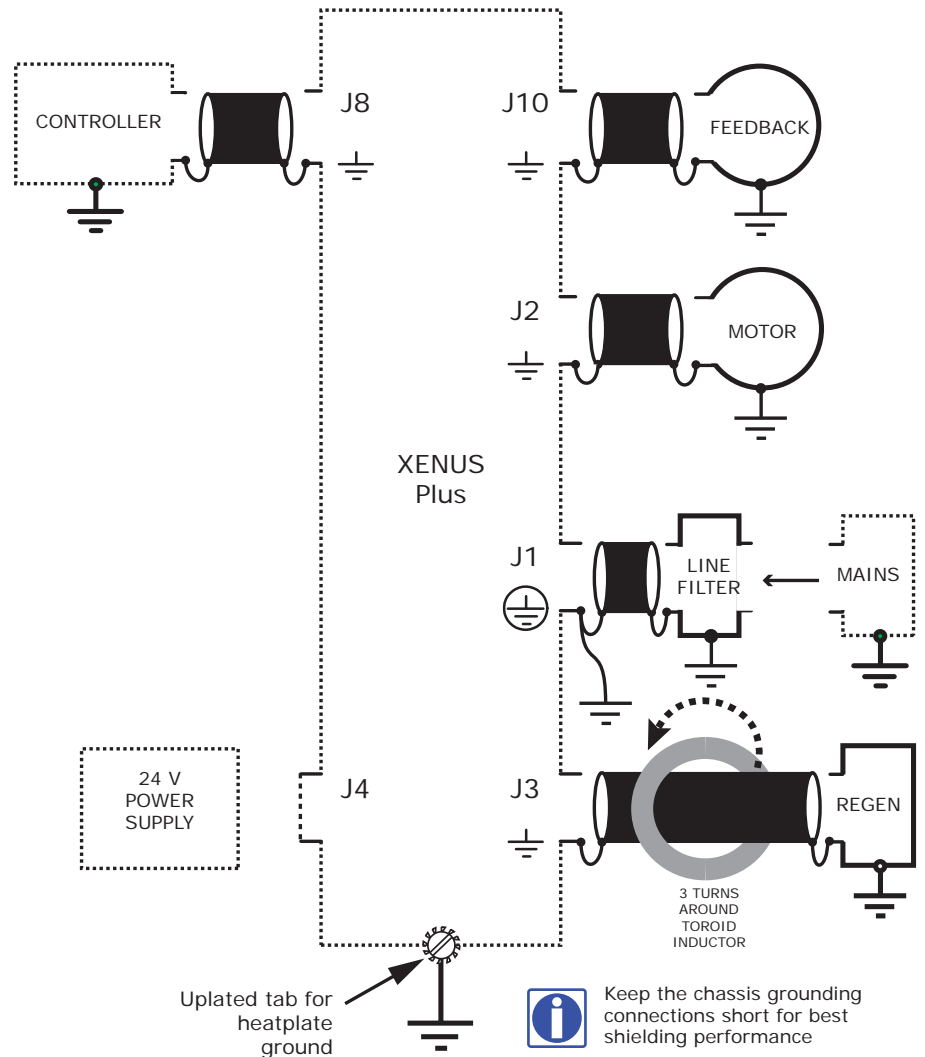

Notes:

- 1) Shielded cables required for CE are shown in the diagram above.
- 2) Line filter required for CE
- 3) Ferrite core required for shielded cable to regen resistor which must be in shielded enclosure.

HEATSINK & FAN CONFIGURATIONS

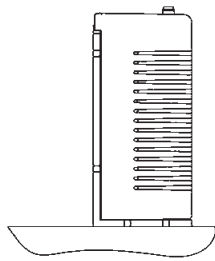

NO HEATSINK
NO FAN



NO HEATSINK
WITH FAN

NOTE: FANS ARE NOT INCLUDED WITH HEATSINKS OR HEATSINK KITS

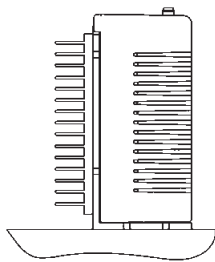

LOW-PROFILE HEATSINK
NO FAN



LOW PROFILE HEATSINK
WITH FAN

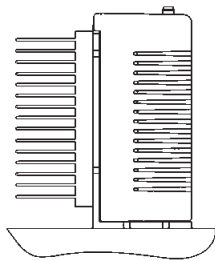

STANDARD HEATSINK
NO FAN

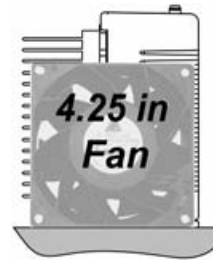

STANDARD HEATSINK
WITH FAN

HEATSINK MOUNTING

A dry-film interface pad is used in place of thermal grease. The pad is die-cut to shape and has holes for the heat sink mounting screws. There are two protective sheets, blue on one side and clear on the other. Both must be removed when the interface pad is installed.

STEPS TO INSTALL

1. Remove the blue protective sheet from one side of the pad and place the pad on the drive. Make sure that the holes in the pad align with the holes on the drive.
2. Remove the clear protective sheet from the pad.
3. Mount the heatsink onto the drive taking care to see that the holes in the heatsink, pad, and drive all line up.
4. Torque the #6-32 mounting screws to 8~10 lb-in (0.9~1.13 N·m).

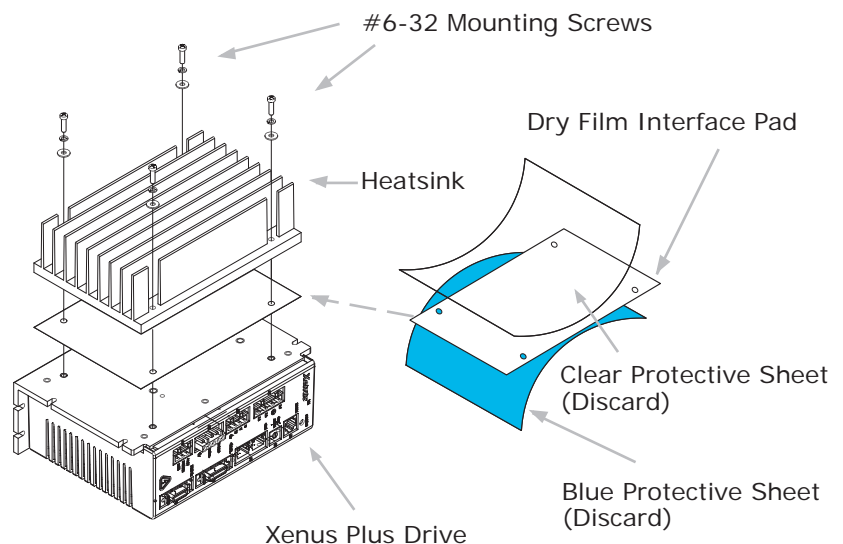

MAXIMUM OPERATING TEMPERATURE VS HEATSINK TYPE & AIR CIRCULATION

The charts below show that maximum ambient temperature vs. continuous output current for the Xenus Plus models. The cooling options are no heatsink, standard heatsink, and low-profile heatsink. For each of these the drive can be operated with convection or forced-air cooling.

XEL-230-18

Mains: 120 Vac

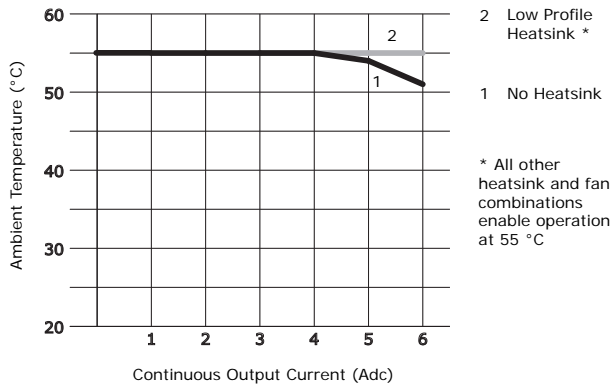

XEL-230-18

Mains: 240 Vac

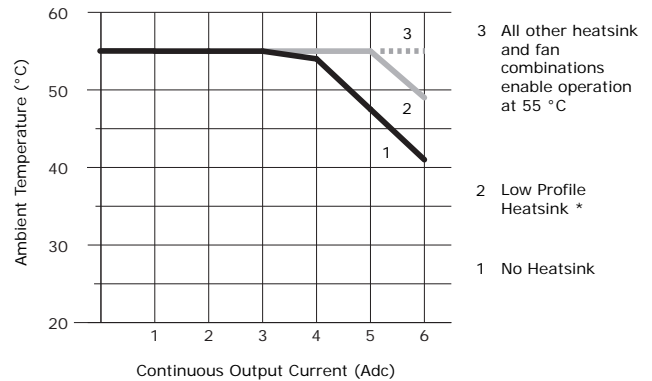

XEL-230-36

Mains: 120 Vac

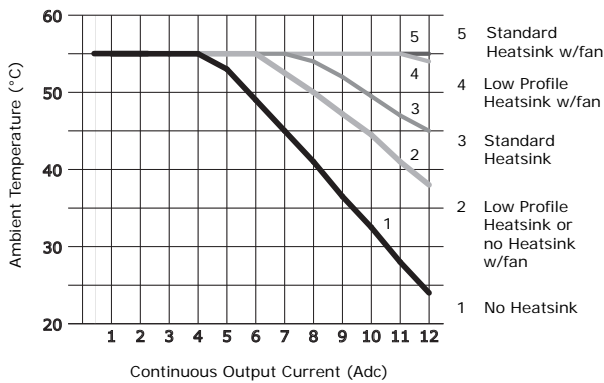

XEL-230-36

Mains: 240 Vac

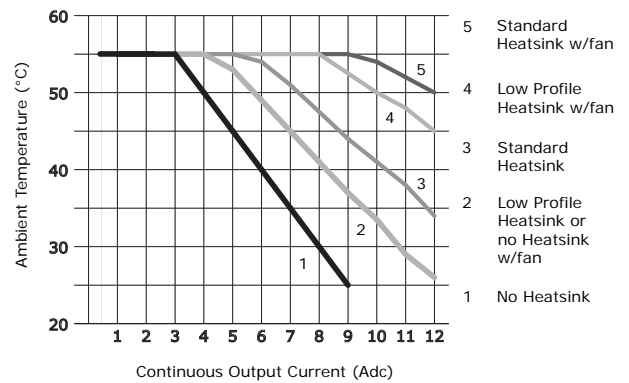

XEL-230-40

Mains: 120 Vac

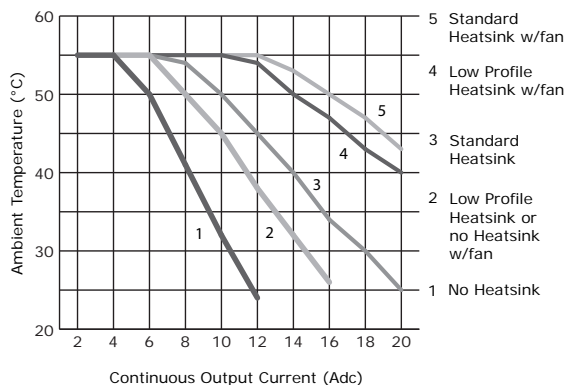

XEL-230-40

Mains: 240 Vac

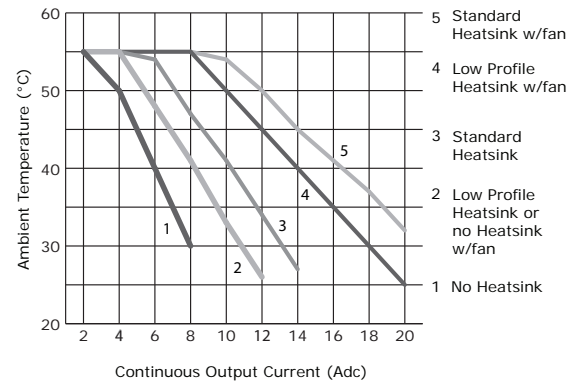

ORDERING GUIDE

XEL-230-18	Xenus Plus EtherCAT Servo Drive 6/18 Adc
XEL-230-36	Xenus Plus EtherCAT Servo Drive 12/36 Adc
XEL-230-40	Xenus Plus EtherCAT Servo Drive 20/40 Adc



ServoTube motors work with XEL servo drives.
 More information on these products can be found here:
<http://www.copleycontrols.com/Motion/Products/Motors/index.html>

Add "-R" to model number for resolver option

ACCESSORIES

	QTY	REF	DESCRIPTION	MANUFACTURERS PART NUMBER
XEL-CK Connector Kit with Solder Cup Connectors for J5, J8, J9 & J10	1	J1	Plug, 4 position, 7.5 mm, female	Wago: 51118287 or 721-204/026-045/RN01-0000
	1	J2	Plug, 4 position, 5.0 mm, female	Wago: 51118008 or 721-104/026-047/RN01-0000
	1	J3	Plug, 5 position, 5.0 mm, male	Wago: 51111279 or 721-605/000-044/RN01-0000
	1	J4	Plug, 3 position, 5.0 mm, female	Wago: 51117974 or 721-103/026-047/RN01-0000
	4	J1~4	Tool, wire insertion & extraction (for J1~4)	Wago: 231-131
	1	J5	Connector, D-Sub, 9-position, male, solder cup	Norcomp: 171-009-103L001
	1		Backshell, D-Sub, RoHS, metallized, for above	Norcomp: 979-009-020R121
	1	J8	Connector, high-density D-Sub, 26 position, female, solder cup	Norcomp: 180-026-203L001
	1		Backshell, D-Sub, RoHS, metallized, for above	Norcomp: 979-015-020R121
	1	J9	Connector, high-density D-Sub, 15 position, male, solder cup	Norcomp: 180-015-103L001
	1		Backshell, D-Sub, RoHS, metallized, for above	Norcomp: 979-009-020R121
	1	J10	Connector, high-density D-Sub, 26 position, male, solder cup	Norcomp: 180-026-103L001
	1		Backshell, D-Sub, RoHS, metallized, for above	Norcomp: 979-015-020R121
CME 2	J5	CME 2 Drive Configuration Software (CD-ROM)		
SER-CK		RS-232 Cable Kit		
XEL-NC-10	1	n/a	EtherCAT® network cable, 10 ft (3 m)	
XEL-NC-01	1	n/a	EtherCAT® network cable, 1 ft (0.3 m)	

Heatsink Kits for Field Installation (Optional)

XEL-HL Heatsink Kit Low-Profile	1	Heatsink, low-profile
	1	Heatsink thermal material
	4	Heatsink hardware
XEL-HS Heatsink Kit Standard	1	Heatsink, standard
	1	Heatsink thermal material
	4	Heatsink hardware

Regeneration Resistors (Optional)

XTL-RA-03	Regeneration resistor assembly (for XEL-230-18), 30 Ω
XTL-RA-04	Regeneration resistor assembly (for XEL-230-36 & XEL-230-40 models), 15 Ω

Edge Filter (Optional)

XTL-FA-01	Edge filter		
Edge Filter Connector Kit XTL-FK	1	Plug, 4 position, 5.0 mm, female	Wago: 51118008 or 721-104/026-047/RN01-0000
	1	Plug, 5 position, 5.0 mm, male	Wago: 51111277 or 721-605/000-044/RN01-0000
	2	Tool, wire insertion & extraction	Wago: 231-131

Example: Order one Xenus Plus drive, resolver version, 6/18 A with solder-cup connector Kit, CME 2 CD, serial cable kit and small heatsink fitted at the factory:

Qty	Item	Remarks
1	XEL-230-18-R-HS	Xenus Plus servo drive
1	XEL-CK	Connector Kit
1	CME 2	CME 2 CD
1	SER-CK	Serial Cable Kit

Note: The heatsink can be fitted at the factory by adding an "-HS" or "-HL" to the drive part number to specify the standard or low-profile type. For fitting a heatsink to an drive in the field, complete kits are available (XEL-HS and XEL-HL). These kits contain the heatsink, mounting hardware, and dry-film interface.