



LINEAR MOTION TECHNOLOGY

MR Miniature Linear Guide Series
ST Miniature Stroke Slide Series

Company Profile

Chieftek Precision Co., Ltd. has put every effort on research and development of linear motion products. By manufacture the key components, contribution and keep on operation.

cpc miniature linear guide was produced in year 2000, as a key component for the precision measurement and inspection instrument.

Recently, the semiconductor machinery equipments, electronics and peripheral industry are rising. Product miniaturization with high function density has become the necessary requirements and result in mechanical key component.

cpc linear guide is an extensively application to most of the machinery in the modern technology today, such as, semiconductor machinery equipment, small machinery, ROBOT, fixture, tool, consumer OA product, and high price computer peripheral equipment fields.

cpc has integrated professional and talent people, as the technical and operational team. We are taking a broad view with an aim to become the market leader in linear motion components.



- | | |
|------|--|
| 1998 | Establishment |
| 2000 | Official production of miniature linear guide |
| 2004 | Production of miniature linear guide size MR3M |
| 2005 | Establishment of workshop in Tainan Science Park |
| 2007 | Production of AR/HR linear guide certified by ISO 9001:2000 |
| 2008 | Established cpc USA
Established cpc KUNSHAN IN CHINA
Publication of LM-PC linear motor |



Table of Contents

1. MR Miniature Linear Guide series

1.1 Products introduction	02
1.2 New Design	04

2. Technical Information

2.1 Precision	07
2.2 Preload	08
2.3 Lubrication	09
2.4 Friction	12
2.5 Load capacity and rating life	13

3. Order Information

16

4. Installation Illustration

18

5. Dimensions and Specification

5.1 Standard MR-M SS series	20
5.2 Standard MR-M ZZ series	22
5.3 Standard MR-M EE series	24
5.4 Standard MR-M EZ series	24
5.5 Standard MR-M EU series	26
5.6 Standard MR-M UZ series	26
5.7 Wide MR-W SS series	28
5.8 Wide MR-W ZZ series	30
5.9 Wide MR-W EE series	32
5.10 Wide MR-W EZ series	32
5.11 Wide MR-W EU series	34
5.12 Wide MR-W UZ series	34
5.13 Upward Screwing Standard MRU-M series	36
5.14 Upward Screwing Wide MRU-W series	36

ST Miniature Stroke Slide series

1. Products Introduction	38
2. Technical Information	40
3. Order Information	41
4. Dimensions and Specification	42

AR/HR series Lubrication Storage testing report

44

1. Products Introduction

1.1 MR Miniature Linear Guide series



■ Embedded inverse hook design



■ Design for high load, high moment

■ **Precision**

MR Miniature linear guide series have three accuracy options for design choice. Precision (P) , High (H) , Normal (N).

- **Unique ball re-circulation design**

- **Reinforcement plate design**

- **Bottom seal**

- **Lubrication storage design: Ecology System**

- **Material**

MR miniature linear guide series regardless of steel rail, steel body of stock or steel ball all use stainless steel quenched process material.

Securely embrace and prevent objects interfere between rail and block, achieved dust proof result.

1. Products Introduction

1.2 New Design

Embedded inverse hook design for reinforcement mechanical integration

When block is in motion, the steel balls circulating inside the raceway during direction change movement it generate impact force to the plastic end cap.

As the demands on rapid motion automation industry has increase. **cpc** has invented new design to improved high speed running capability. New designed plastic inverse hook for miniature linear block, tightly secure block components to handle the impact force.

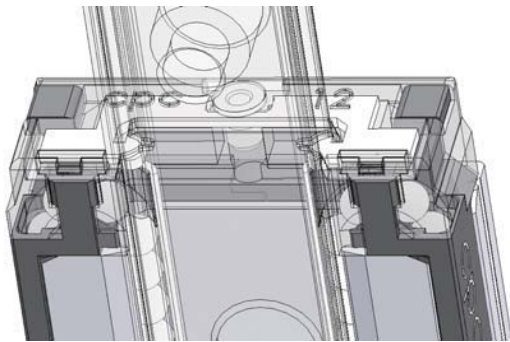

Brand new design

Suitable for :
 High speed belt driven mechanism
 High speed carrier design
 Automation linkage between station

Unique ball re-circulation design

The stainless steel ball re-circulation hole and channel construct of fully sealed by plastic end cap.

The structure uncomplicated but could substantially reduce contact surface between stainless steel ball and metal. This design could achieve low noise running environment. The lubrication oil storage design embedded in circulation channel extend lubricate interval.

Bottom Seal MR..EU/UZ series (9M/W, 12M/W, 15M/W)

New design stainless steel bottom seal remains minimum gap. Effectively stop object interfere between block and rail surface. The bottom seal can increase block longevity without compromise running smoothness.

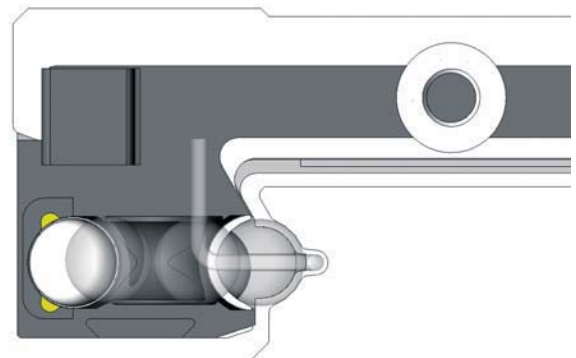
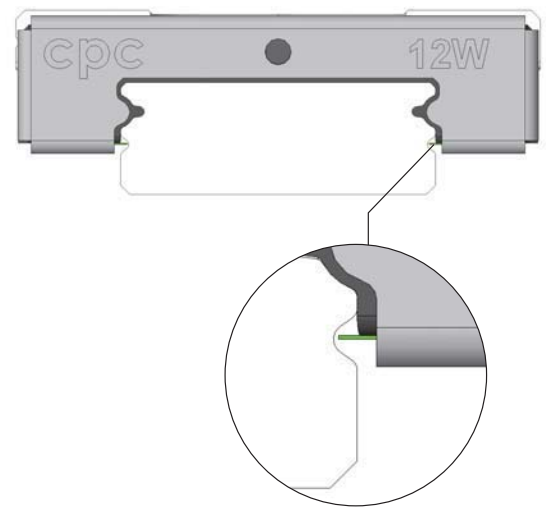

MR..EE series stainless steel reinforcement plates emerge high robustness

To adopt two stainless steel plates with fully covering design in order to completely wrap up plastic end cap of Block from end to end.

At the same time use stainless steel screw firmly lock on top and bottom of steel body, reinforce end cap as support higher running speed.

Between the reinforcement plate and rail is gap seal design, so the reinforcement plates also equip scraper function. If choose preload design could emerge higher speed, higher rigidity feature.

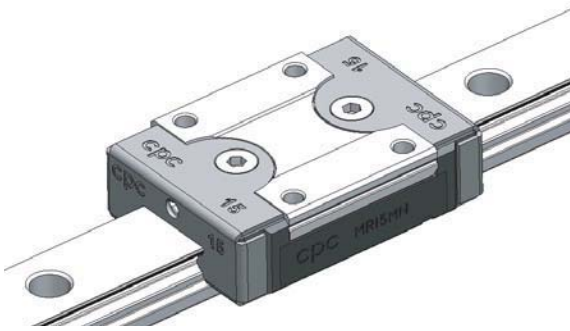

Lubrication storage pad design

Design of lubricant injection holes on both ends of block. Via ball circulating movement, steel balls carry lubrication oil to the rail raceway. Efficiently lubricate steel balls and rail raceway, achieved long term maintenance free. Superb lubricating ability for short stroke movement as well. Newly invented embedded lubrication pad design, provide an optional selection for machine designing.

(3M/W,5M/W,7M/W,9M/W,12M/W,15M/W)

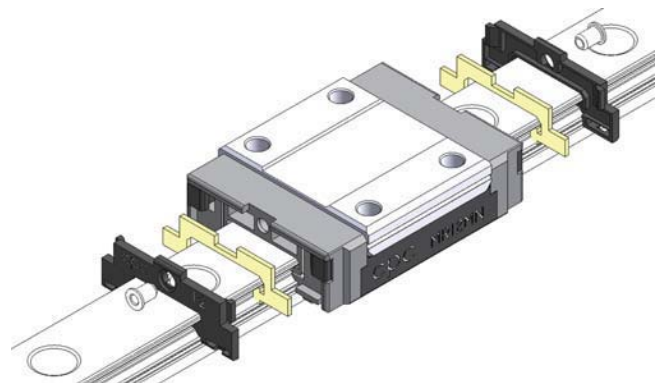

1. Products Introduction

High load and high moment capacity

MR Miniature Linear Guide series incorporate the design of two rows of ball re-circulation, Gothic profile design with 45° contact angle to attain the effect of equal load capacity in all directions. Under the restriction of limited space, larger steel balls are used to enhance the load and torsion resistance capacity.

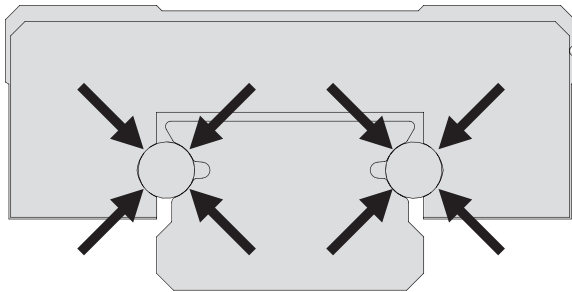

Gothic profile design with 45° contact angle to attain the effect of equal load capacity in all directions.

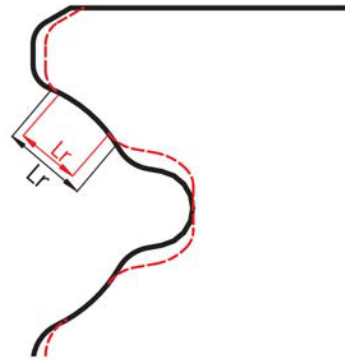

Under the same width of rail, **cpc** linear guide (shown as black full line) has larger contact surface compare to competitors (shown as red dot line).

Dust Proof Design

The standard equipped end seal design, effectively prevent from dust, for longer product lifetime and well preserve lubricant to ensure long time effective lubrication. Special design low friction seal lips do not take effect on running smoothness.

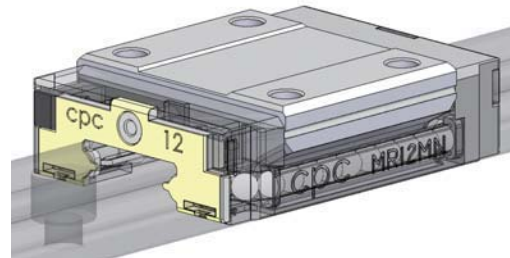

2. Technical Information

2.1 Precision

Accuracy

MR Miniature Linear Guide series have three accuracy grades P,H,N for your choice.

		Table of accuracy		
Accuracy classes (µm)		Precision P	High H	Normal N
Tolerance of dimension height H	H	± 10	± 20	± 40
Variation of height for different runner Block on the same position of Rail	ΔH	7	15	25
Tolerance of dimension width W	W ₂	± 15	± 25	± 40
Variation of width for different runner Block on same position of Rail	ΔW ₂	10	20	30

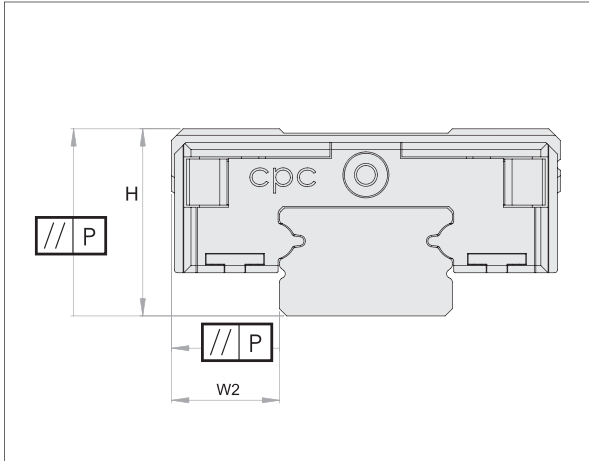

Speed

The maximum speed for the standard MR-SS/ZZ type is :

V_{max} = 3 m/s

Maximum acceleration

A_{max} = 250 m/s²

(If preload V0, capable to reach 40m/s²)

The maximum speed for the standard MR-EE/EZ/EU/UZ type is **V_{max} > 5 m/s**

Maximum acceleration **A_{max} = 300 m/s²**

(If preload V0, capable to reach 60m/s²)

Accuracy of the running parallelism

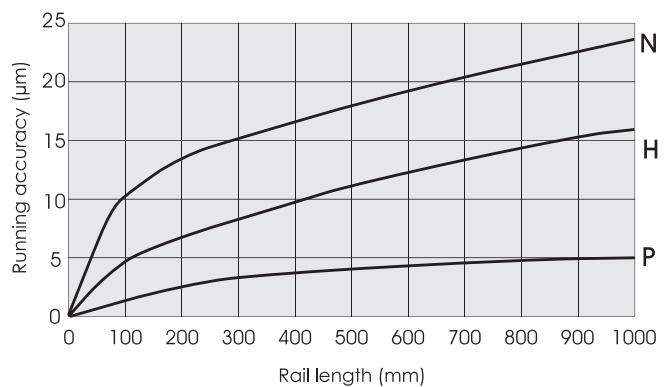

2. Technical Information

2.2 Preload

Preload

The MR Miniature Linear Guide series have three degrees of preload V0, VS and V1 as described in the table of preload below. Preload can enhance stiffness, precision, and torsion resistance, but will affect life and friction.

Table of Preload

Preload type	Model code	Clearance (um)						Application
		3	5	7	9	12	15	
Clearance	V0	+3 - 0	+3 - 0	+4 - 0	+4 - 0	+5 - 0	+6 - 0	Very smooth
Standard	VS	+1 - 0	+1 - 0	+2 - 0	+2 - 0	+2 - 0	+3 - 0	Smooth and precision
Light preload	V1	0 -- 0.5	0 -- 1	0 -- 3	0 -- 4	0 -- 5	0 -- 6	High rigidity Minimize vibration High precision Load balance

Operation Temperature

The MR Miniature Linear Guide can operate in a range of temperatures from -40°C~ + 80°C. For short term operation it can reach up to +100°C.

2.3 Lubrication

Function

The loaded rolling elements and the raceway will be separated at the contact zone by a thin layer of oil. The lubrication will therefore:

- Reduce friction
- Reduce corrosion
- Reduce wear
- Dissipate heat and increase service life

Lubrication Caution

- The guide must be lubricated as the protection for the first time use, and avoid pollution in any kind.
- The runner Block should be moved back and forth during the lubrication.
- Generally the lubricant is added onto rail raceway.
- The lubricant can be injected into the lubrication holes on either end of the runner Block.
- A thin layer of lubricant should be maintained on the surface of the Rail raceway.
- Re-lubricate before contamination or discoloration of the lubricant occurs.
- Please notify when use in acids, alkaline and clean room environment.
- Contact our technical service oil lubrication is used when the runner Block is in a wall mount configuration.
- The re-lubrication interval must be shortened if the travel stroke is < 2 or > 15 times the length of the steel body of the runner Block.

Grease lubrication

When grease lubrication is used we recommend synthetic oil based lithium-soap grease with a viscosity between ISO VG32-100

Oil lubrication

We recommend the synthetic oil CLP or CGLP based on DIN 51517 or HLP based on DIN 51524 and the viscosity ranges between ISO VG32-100 by the working temperature between $0^{\circ}\text{C} \sim +70^{\circ}\text{C}$ are recommended (We recommend ISO VG10 for use in lower temperature environment).

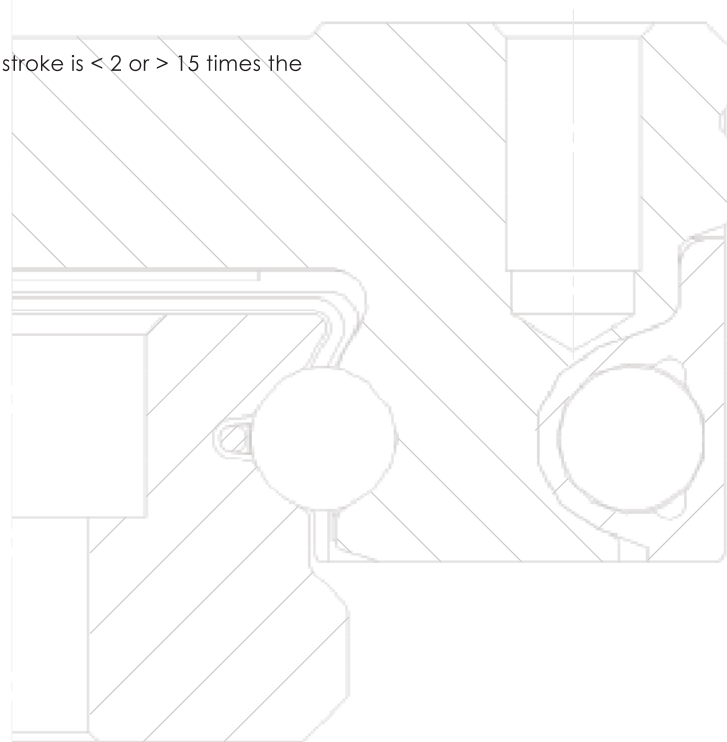

2. Technical Information

2.3 Lubrication

Re-lubrication

- Re-lubrication shall be applied before the lubricant on the Block is contained or change the color.
- The amount of the lubricant is the 1/2 of the first lubrication (see table 1).
- Re-lubrication shall be applied under operation temperature and in the meantime the Block moved back and forth.
- If the stroke is smaller than twice or greater than 15 times of the steel body length of the Block; the re-lubrication interval shall be shorted.

Table 1

Model code	First lubrication (cm ³)	Model code	First lubrication (cm ³)
5 MN	0.03	5 WN	0.04
5 ML	0.04	5 WL	0.05
7 MN	0.12	7 WN	0.19
7 ML	0.16	7 WL	0.23
9 MN	0.23	9 WN	0.30
9 ML	0.30	9 WL	0.38
12 MN	0.41	12 WN	0.52
12 ML	0.51	12 WL	0.66
15 MN	0.78	15 WN	0.87
15 ML	1.05	15 WL	1.11

Re-lubrication Interval

The speed, the load, the stroke length and the operating environment affect re-lubrication interval.

A safe re-lubrication interval can only be obtained by practical observation.

Re-lubrication interval shall not exceed one year.

Lubrication can be applied through the injection hole on the both ends of the block by using a special injector. The injector is offered by **cpc**.

Lubrication grease

- 00 for general application
- 01 for low friction low noise application
- 02 for clean room application
- 03 for clean room and vacuum application
- 04 for high speed application
- 05 for micro oscillation application

Lubrication oil

- 11 for general application ISO V32-68

Ordering of the lubrication injector

<u>LUB</u>	—	<u>01</u>	—	<u>18G</u>
Lubricant :				Needle model :
00				21G: 5M/5W
01				20G: 7M
02				19G: 7W
03				18G: 9M/9W
04				18G: 12M/12W
05				15G: 15M/15W
11				

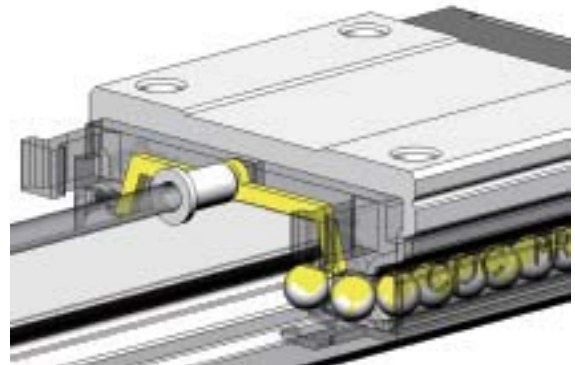

Lubricant amount: 10ml



2. Technical Information

2.4 Friction

Friction

The MR Miniature Linear Guide series have low friction characteristics, with a stable and minor starting friction.

Sealing Design

The MR Miniature Linear Guide series are sealed by end seal on both ends of the runner block. Optional side seals build an all-around closed sealing system.

		Friction		
		Friction with End Seal under lubrication		
$F_m = \mu \cdot F$	——(1)	MR size	Friction with End Seal (Nmax) (under lubrication)	
			M	W
F	Load (N)	2	0.08	0.2
F_m	Friction (N)	3	0.08	0.2
		5	0.08	0.2
		7	0.1	0.4
		9	0.1	0.8
		12	0.4	1.0
		15	1.0	1.0

MR Miniature Linear Guide series friction factor is $\mu = 0.002 \sim 0.003$ approximately

Factors of friction

- Sealing system.
- Collision between the balls during operation.
- Collision between the balls and the return path.
- Of the balls in the Gothic arch load zone.
- Resistance from the churning of the lubricant in the runner Block.
- Interfered objects.



2.5 Load capacity and rating life

Static load rating C_0

The static load along the acting direction; under this loading, the maximum calculated stress at the rolling elements and the raceway by a curvature radius $\cong 0.52$ is 4200 MPa and by a curvature radius $\cong 0.6$ is 4600 MPa.

Note: at this contact point under such stress, a permanent total deformation is generated corresponding to about 0.0001 times of the rolling element diameter. (The above is according to ISO 14728-2)

Static load safety factor calculation

$S_0 = C_0 / P_0$ — (11)	Operation condition	S_0
$S_0 = M_0 / M$ — (12)		
$P_0 = F_{max}$ — (13)	Load with vibration or impact	2 ~ 3
$M_0 = M_{max}$ — (14)		
	High accuracy and smooth running	$\cong 3$

Static load P_0 and moment M_0

Permissible static load The applying static load of the MR Miniature Linear Guide is limited as follows:

- Static load of the linear guide.
- Permissible load of fixing screws.
- The permissible load of the related parts of the mechanism.
- The static load safety factor required for the application.

The equivalent static load and static moment are the largest load and moment, referred to formulas (13) and (14).

Static load safety factor S_0

Under the static load safety factor, the linear guide system demonstrates a reliable operation and running accuracy as required in application. The static load safety factor S_0 is calculated by the formulas (11) and (12).

- S_0 static load safety factor
- C_0 basic static load in action direction N
- P_0 equivalent static load in action direction N
- M_0 basic static moment in action direction Nm
- M equivalent static moment in action direction Nm

2. Technical Information

Dynamic load rating C

When the dynamic loads are applied normal to the load zones with constant magnitude and direction, theoretically; the rating life of linear guide can reach 100km of travel distance. (The above is according to ISO 14728-1).

Rating life calculation

$$C_{50B} = 1.26 \cdot C_{100B} \quad \text{--- (2)}$$

$$C_{100B} = 0.79 \cdot C_{50B} \quad \text{--- (3)}$$

$$L = \left(\frac{C_{100B}}{P} \right)^3 \cdot 10^5 \quad \text{--- (4)}$$

$$L_h = \frac{L}{2 \cdot s \cdot n \cdot 60} = \frac{L}{v_m} \cdot \left(\frac{C_{100B}}{P} \right)^3 \quad \text{--- (5)}$$

L	= Rating life for travel distance 100,000 meter	(m)
L _h	= Rating life in hour	(h)
C _{100B}	= Dynamic load rating	(N)
P	= Equivalent load	(N)
s	= Length of stroke	(m)
n	= Stroke repetition	(min ⁻¹)
v _m	= Average speed	(m/min)

Rating Life L

An individual Linear Guide or a batch of identical Linear Guide under the same running conditions, using common materials with normal manufacturing quality and operating conditions can reach a 90% survival rate at the calculated life. (The above is according to ISO 14728-1) When the standard of 50km travel distance is used, the dynamic load rating will exceed the value based on the standard ISO 14728-1 by 20% or more. The relationship between two load ratings is based on formula (2).

Calculation of rating life

Formulas (4) and (5) can be used when the equivalent dynamic load and the average speed are constant.

Equivalent dynamic load and speed

If the load and speed are not constant, each actual load and speed must be taken into account and both will influence the life.

Equivalent dynamic load

If there is a change in load only, the equivalent dynamic load can be calculated according to formula (6).

Equivalent speed

If there is a change in speed only, the equivalent speed can be calculated using formula (7).

If there are changes in both of the load and speed, the equivalent dynamic load can be calculated using formula (8).

Equivalent load capacities and speed calculation

$$P = 3 \sqrt{\frac{q_1 \cdot F_1^3 + q_2 \cdot F_2^3 + \dots + q_n \cdot F_n^3}{100}} \quad \text{--- (6)}$$

$$\bar{v} = \frac{q_1 \cdot v_1 + q_2 \cdot v_2 + \dots + q_n \cdot v_n}{100} \quad \text{--- (7)}$$

$$P = 3 \sqrt{\frac{q_1 \cdot v_1 \cdot F_1^3 + q_2 \cdot v_2 \cdot F_2^3 + \dots + q_n \cdot v_n \cdot F_n^3}{100 \bar{v}}} \quad \text{--- (8)}$$

$$P = |F_x| + |F_y| \quad \text{--- (9)}$$

$$P = |F| + |M| \cdot \frac{C_0}{M_0} \quad \text{--- (10)}$$

P	=	Equivalent dynamic load	(N)
q	=	Percentage of stroke	(%)
F ₁	=	Discrete load steps	(N)
\bar{v}	=	Average speed	(m/min)
v	=	Discrete speed steps	(m/min)
F	=	External dynamic load	N
F _y	=	External dynamic load, vertical	N
F _x	=	External dynamic load, horizontal	N
C ₀	=	Static load rating	N
M	=	Static moment	Nm
M ₀	=	Static moment in direction of action	Nm

Combined dynamic load

If the Linear Guide takes on load from an arbitrary angle, its equivalent dynamic load rating is calculated using formula (9).

Combined load in combination with a moment

If both load and moment act on the Linear Guide, the equivalent dynamic load can be calculated by the formula (10).

According to ISO 14728-1, the equivalent load (P) shall not exceed 1/2C.

3. Order Information

3.1 Length of Rail

Length of Rail

Perform butt-joint treatment when required lengths exceed Lmax. (For detail information please contacts cpc technical support.)

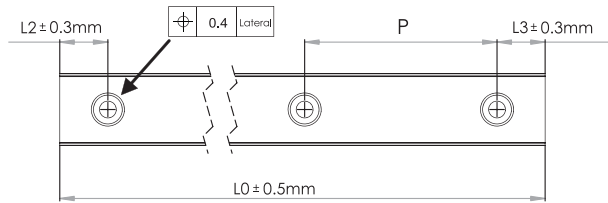

Model Code													
MR	U	15	M	N	EE	2	V1	P	-310L	-15	-15	II	J
													Customization code
													Number of Rail on the same moving axis
													End hole pitch (mm)
													Starting hole pitch (mm)
													Rail length (mm)
													Accuracy classes : P(Precision) \ H(High) \ N(Normal)
													Preload classes : V0 : Clearance VS : Standard V1 : Light Preload
													Block quantity : Quantity of the runner Block
Seals SS : With End Seal type EE : With End Seal plus Reinforcement Plate(available for size 2WL , 5M , 7W , 9M/W, 12M/W, 15M/W) ZZ : With End Seal plus Lubrication Storage (available for size 2WL , 3M/W , 5M/W , 7 M/W, 9M/W, 12M/W, 15M/W) EZ : With End Seal plus Lubrication Storage plus Reinforcement Plate (available for size 2WL , 5M , 7W , 9M/W, 12M/W, 15M/W) EU : With end seal + Reinforcement + Bottom End seal UZ : With end seal + Reinforcement + Bottom End seal + Lubrication Storage													
													Block type : L : Long N : Standard
													Rail type : M : Standard W : Wide
													Rail dimension : The width of Rail ex. : 2 \ 3 \ 5 \ 7 \ 9 \ 12 \ 15
													Special Rail U : Upward Screwing Rail No Mark : Standard Rail
Product Type: MR: Miniature Linear Guide													

Standard type							
size	3M	5M	7M	9M	12M	15M	
Standard length of one Rail (mm)	30	40	40	55	70	70	
	40	55	55	75	95	110	
	50	70	70	95	120	150	
		85	85	115	145	190	
		100	100	135	170	230	
			130	155	195	270	
				175	220	310	
				195	245	350	
				275	270	390	
				375	320	430	
					370	470	
					470	550	
					570	670	
						870	
Pitch (mm)	10	15	15	20	25	40	
L2 , L3min	3	3	3	4	4	4	
L2 , L3max	5	10	10	20	20	35	
Lmax	300	1000	1000	1000	1000	1000	

Wide type									
size	2W	3W	5W	7W	9W	12W	15W		
Standard length of one Rail (mm)	30	40	50	50	50	70	110		
	40	55	70	80	80	110	150		
	50	70	90	110	110	150	190		
			110	140	140	190	230		
			130	170	170	230	270		
			150	200	200	270	310		
			170	260	260	310	430		
				290	290	390	550		
					320	470	670		
						550	790		
	Pitch (mm)	10	15	20	30	30	40	40	
	L2 , L3min	3	3	4	3	4	4	4	
	L2 , L3max	5	10	15	25	25	35	35	
	Lmax	300	1000	1000	1000	1000	1000	1000	

Customization Requirement

The meaning of suffix characters:

J : Butt-jointing track Rail

G : Customer designate lubricant

I : Inspection report

C3 : Cap M3

C4 : Cap M4

R : Special process for Rail

B : Special process for Block

S : Special straightness for Rail

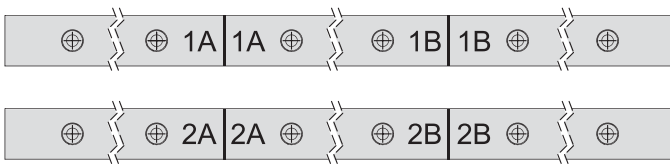

J : Butt-Jointing track Rail

When the length of customer required rail, over the provided rail length, can make in way of connection. The rail butt-joint indication is marked, show as illustration above.

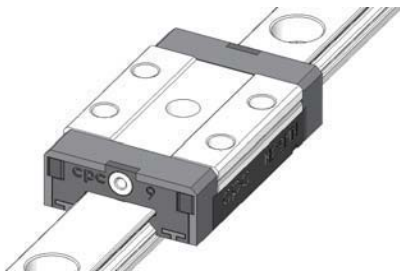

B : Special process for Block

For special process requirement, please contact technical service.

R : Special process for Rail

For special process requirement, please contact technical service.

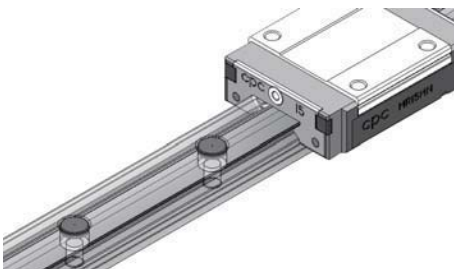

S : Special straightness for Rail

The linear guide rail straightness been special calibrated by precision fine grinding.

G : Customer designate lubricant

According to application environment.

GN : No lubricant

GC : low dust generation, suit for clean room environment.

C3 CapM3 :

Apply to MR9M. MR12M. MR15M. MR7W & MR9W Rail

C4 CapM4 :

Apply to MR12W . MR15W Rail

I : Inspection report

Please contact technical department.

4. Installation Illustration

Height and chamfered the reference edge

To avoid any interference, the corner of the reference edge with chamfered is recommended. If not so, please refer to the following table for the height of the reference edge corner and the height of the reference edge.

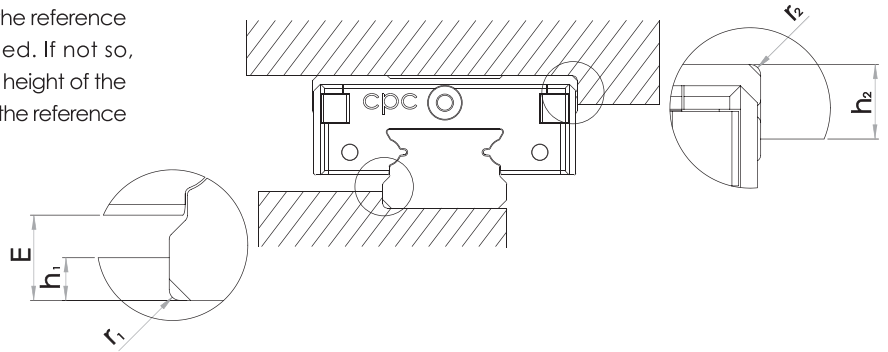

Height and chamfered the reference surface

Dimension	h ₁	r _{1max}	h ₂	r _{2max}	E
3M SS	0.5	0.2	1.5	0.3	1
5M SS	1.2	0.2	1.9	0.3	1.5
7M SS/ZZ	1.2	0.3	2.8	0.3	1.5
9M SS/ZZ	1.5	0.3	3	0.3	2.2
12M SS/ZZ	2.5	0.5	4	0.5	3
15M SS/ZZ	2.5	0.5	4.5	0.5	4
5M EE/EZ	0.6	0.2	1.9	0.3	1.1
9M EE/EZ	1.2	0.3	3	0.3	1.7
12M EE/EZ	1.5	0.5	4	0.5	2.3
15M EE/EZ	2.5	0.5	4.5	0.5	3.2
9M EU/UZ	1	0.3	3	0.3	1.4
12M EU/UZ	1.5	0.5	4	0.5	2
15M EU/UZ	2	0.5	4.5	0.5	2.9

Dimension	h ₁	r _{1max}	h ₂	r _{2max}	E
2WL SS/ZZ	0.5	0.2	1.7	0.3	1
3W SS	0.7	0.2	1.7	0.3	1
5W SS	1	0.2	2	0.3	1.5
7W SS/ZZ	1.5	0.3	2.8	0.3	2
9W SS/ZZ	2.5	0.3	3	0.3	3.4
12W SS/ZZ	2.5	0.5	4	0.5	3.9
15W SS/ZZ	2.5	0.5	4.5	0.5	4
2WL EE/EZ	0.4	0.2	1.5	0.3	0.7
7W EE/EZ	1	0.3	2.8	0.3	1.5
9W EE/EZ	2	0.3	3	0.3	2.8
12W EE/EZ	2.5	0.5	4	0.5	3.3
15W EE/EZ	2.5	0.5	4.5	0.5	3.2
9W EU/UZ	1.5	0.3	3	0.3	2.5
12W EU/UZ	2	0.5	4	0.5	3
15W EU/UZ	2	0.5	4.5	0.5	2.9

The mounting surface

Surface roughness

The mounting surface should be ground or fine milled to reach a surface roughness Ra1.6.

Screw tightening moment (Nm)

Screw grade	Steel	Cast Iron	Non Iron Metal
12.9			
M2	0.6	0.4	0.3
M3	1.8	1.3	1
M4	4	2.5	2

Geometric and positional accuracy of the mounting surface

Inaccurate mounting surfaces will affect the linear guide operation accuracy, when mounting surface height differential is greater than the calculation result (Calculate by formulas (15),(16) and (17). Rating life will be shortening.

$$e1 \text{ (mm)} = b \text{ (mm)} \cdot f1 \cdot 10^{-4} \quad \text{--- (15)}$$

$$e2 \text{ (mm)} = d \text{ (mm)} \cdot f2 \cdot 10^{-5} \quad \text{--- (16)}$$

$$e3 \text{ (mm)} = f3 \cdot 10^{-3} \quad \text{--- (17)}$$

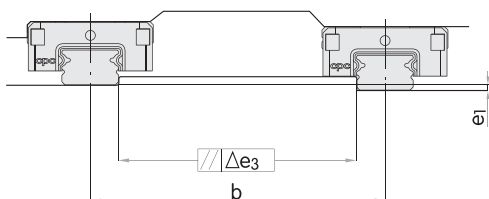

Reference edge

Rail: Both sides of the track rail can be the reference edge without any special marking.

Block: Reference edge is opposite to groove marking side.

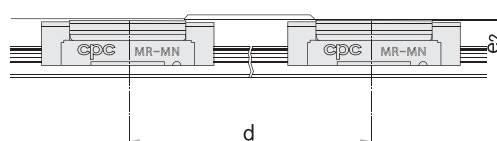

Dimension	V0/VS			V1		
	f1	f2	f3	f1	f2	f3
3MN	4	9	2	3	9	1
5MN	4	8	2	2	8	2
7MN	5	11	4	3	10	3
9MN	5	11	6	4	10	4
12MN	6	13	8	4	12	6
15MN	7	11	12	5	10	8
3ML	4	5	2	3	5	1
5ML	3	5	2	2	5	1
7ML	4	6	4	3	6	3
9ML	5	7	5	3	7	4
12ML	5	8	8	3	7	5
15ML	7	8	11	4	8	7

Dimension	V0/VS			V1		
	f1	f2	f3	f1	f2	f3
2WL	4	5	2	3	5	1
3WN	2	5	2	4	3	1
5WN	2	5	2	1	3	1
7WN	2	6	4	2	4	3
9WN	2	7	6	2	5	4
12WN	3	8	8	2	5	5
15WN	2	9	11	1	6	7
3WL	2	3	1	1	2	1
5WL	2	3	2	1	2	1
7WL	2	4	4	1	3	3
9WL	2	5	5	2	3	3
12WL	2	5	7	2	3	5
15WL	2	5	10	1	4	7

5. Dimensions and Specification

5.1 Standard MR-M SS series

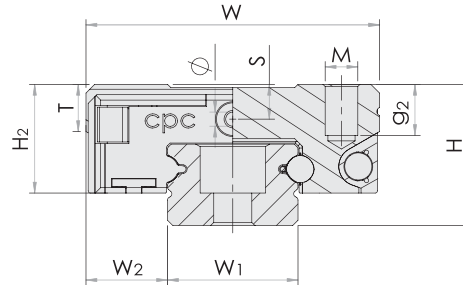

Model Code	Fabricate Dimensions		Rail Dimensions (mm)				Block Dimensions (mm)					
	H	W ₂	W ₁	H ₁	P	D×d×g ₁	W	L	L ₁	H ₂	P ₁	P ₂
MR 15ML SS	16	8.5	15	9.5	40	6 x 3.5 x 4.5	32	60	44	12	25	25
MR 15MN SS	16	8.5	15	9.5	40	6 x 3.5 x 4.5	32	43	27	12	20	25
MR 12ML SS	13	7.5	12	7.5	25	6 x 3.5 x 4.5	27	47.6	34	10	20	20
MR 12MN SS	13	7.5	12	7.5	25	6 x 3.5 x 4.5	27	35.4	22	10	15	20
MR 9ML SS	10	5.5	9	5.5	20	6 x 3.5 x 3.5	20	40.9	30.8	7.8	16	15
MR 9MN SS	10	5.5	9	5.5	20	6 x 3.5 x 3.5	20	30.6	20.5	7.8	10	15
MR 7ML SS	8	5	7	4.7	15	4.2 x 2.4 x 2.3	17	31.2	21.8	6.5	13	12
MR 7MN SS	8	5	7	4.7	15	4.2 x 2.4 x 2.3	17	23.7	14.3	6.5	8	12
MR 5ML SS	6	3.5	5	3.5	15	3.5 x 2.4 x 1	12	19.6	13.5	4.5	7	–
MR 5MN SS	6	3.5	5	3.5	15	3.5 x 2.4 x 1	12	16	10	4.5	–	8
MRU 3ML SS	4	2.5	3	2.6	10	M1.6	8	16	11	3	5.5	–
MRU 3MN SS	4	2.5	3	2.6	10	M1.6	8	11.7	6.7	3	3.5	–

Load capacities are calculated according to ISO 14728, Compare the rating life definition and the load capacities: $C_{508}=1.26 \times C_{1008}$

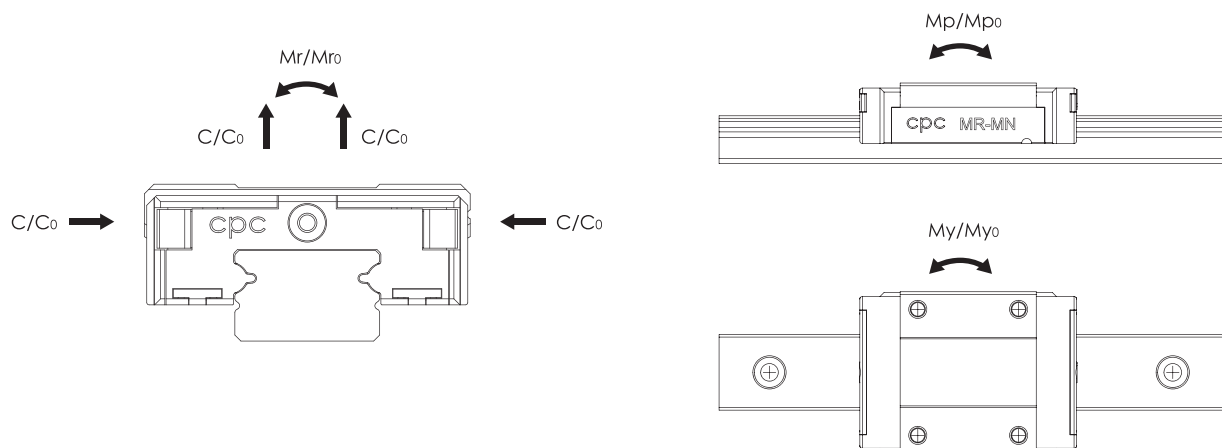

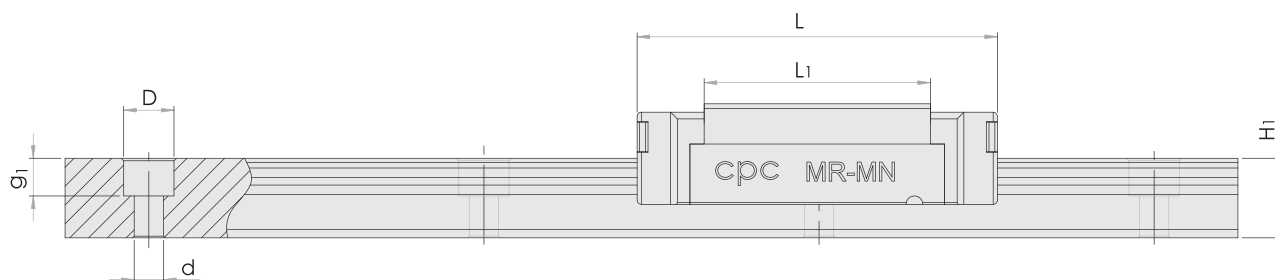

Block Dimensions (mm)				Load Capacities (N)		Static Moment (Nm)			Weight		Model Code
$M \times g_2$	\varnothing	S	T	$C_{100B}(\text{dyn})$	$C_0(\text{stat})$	M_{r0}	M_{p0}	M_{y0}	Block(g)	Rail(g/m)	
M3 x 5.5	1.8	3.3	4.3	5350	9080	70	63.3	63.3	90	930	MR 15ML SS
M3 x 5.5	1.8	3.3	4.3	3810	5590	43.6	27	27	61	930	MR 15MN SS
M3 x 3.5	1.3	3.2	4.3	3240	5630	34.9	30.2	30.2	51	602	MR 12ML SS
M3 x 3.5	1.3	3.2	4.3	2308	3465	21.5	12.9	12.9	34	602	MR 12MN SS
M3 x 3.0	1.3	2.2	3.3	2135	3880	18.2	12.4	12.4	28	301	MR 9ML SS
M3 x 3.0	1.3	2.2	3.3	1570	2495	11.7	6.4	6.4	18	301	MR 9MN SS
M2 x 2.5	1.1	1.6	2.8	1310	2440	9	7.7	7.7	14	215	MR 7ML SS
M2 x 2.5	1.1	1.6	2.8	890	1400	5.2	3.3	3.3	8	215	MR 7MN SS
M2.6 x 2.0	0.7	1.3	2	470	900	2.4	2.1	2.1	4	116	MR 5ML SS
M2 x 1.5	0.7	1.3	2	335	550	1.7	1	1	3.5	116	MR 5MN SS
M2 x 1.1	0.3	0.7	1.5	295	575	0.9	1.1	1.1	1.2	53	MRU 3ML SS
M1.6 x 1.1	0.3	0.7	1.5	190	310	0.6	0.4	0.4	0.9	53	MRU 3MN SS

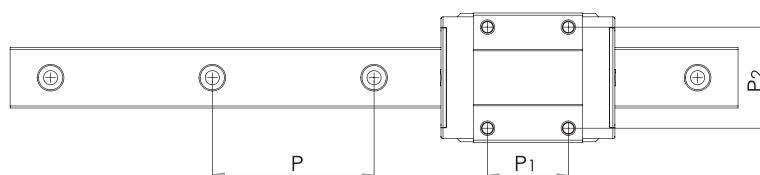

5. Dimensions and Specification

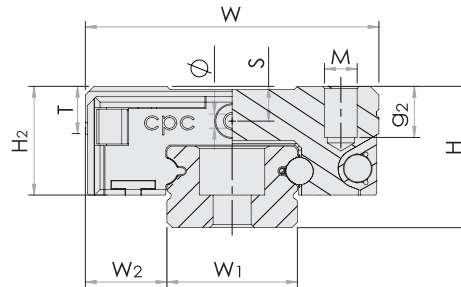

5.2 Standard MR-M ZZ series

Model Code	Fabricate Dimensions		Rail Dimensions (mm)				Block Dimensions (mm)					
	H	W ₂	W ₁	H ₁	P	D×d×g ₁	W	L	L ₁	H ₂	P ₁	P ₂
MR 15ML ZZ	16	8.5	15	9.5	40	6 x 3.5 x 4.5	32	60	44	12	25	25
MR 15MN ZZ	16	8.5	15	9.5	40	6 x 3.5 x 4.5	32	43	27	12	20	25
MR 12ML ZZ	13	7.5	12	7.5	25	6 x 3.5 x 4.5	27	47.6	34	10	20	20
MR 12MN ZZ	13	7.5	12	7.5	25	6 x 3.5 x 4.5	27	35.4	22	10	15	20
MR 9ML ZZ	10	5.5	9	5.5	20	6 x 3.5 x 3.5	20	40.9	30.8	7.8	16	15
MR 9MN ZZ	10	5.5	9	5.5	20	6 x 3.5 x 3.5	20	30.6	20.5	7.8	10	15
MR 7ML ZZ	8	5	7	4.7	15	4.2 x 2.4 x 2.3	17	31.2	21.8	6.5	13	12
MR 7MN ZZ	8	5	7	4.7	15	4.2 x 2.4 x 2.3	17	23.7	14.3	6.5	8	12
MR 5ML ZZ	6	3.5	5	3.5	15	3.5 x 2.4 x 1	12	19.6	13.5	4.5	7	–
MR 5MN ZZ	6	3.5	5	3.5	15	3.5 x 2.4 x 1	12	16	10	4.5	–	8
* MRU 3ML ZZ	4	2.5	3	2.6	10	M1.6	8	16	11	3	5.5	–
* MRU 3MN ZZ	4	2.5	3	2.6	10	M1.6	8	11.7	6.7	3	3.5	–

* Preparing

Load capacities are calculated according to ISO 14728. Compare the rating life definition and the load capacities: $C_{50B} = 1.26 \times C_{100B}$

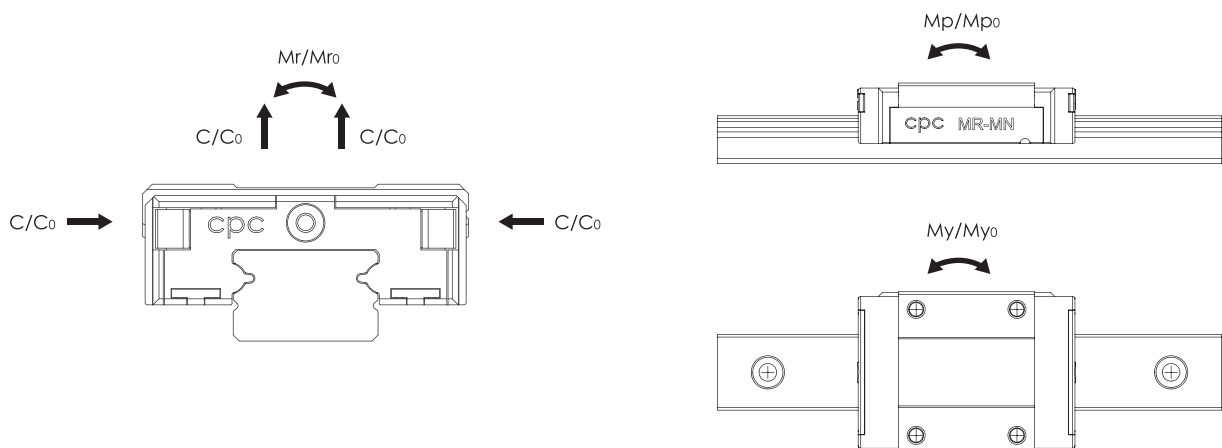

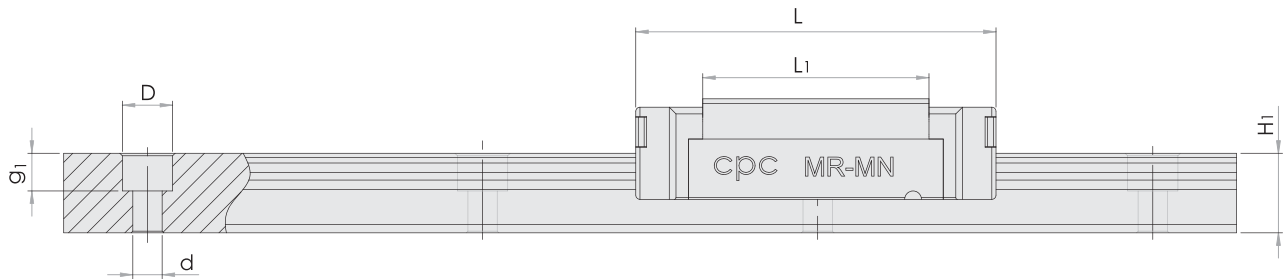

Block Dimensions (mm)				Load Capacities (N)		Static Moment (Nm)			Weight		Model Code
M×g ₂	∅	S	T	C _{100B} (dyn)	C ₀ (stat)	Mr ₀	Mp ₀	My ₀	Block(g)	Rail(g/m)	
M3 x 5.5	1.8	3.3	4.3	5350	9080	70	63.3	63.3	90	930	MR 15ML ZZ
M3 x 5.5	1.8	3.3	4.3	3810	5590	43.6	27	27	61	930	MR 15MN ZZ
M3 x 3.5	1.3	3.2	4.3	3240	5630	34.9	30.2	30.2	51	602	MR 12ML ZZ
M3 x 3.5	1.3	3.2	4.3	2308	3465	21.5	12.9	12.9	34	602	MR 12MN ZZ
M3 x 3.0	1.3	2.2	3.3	2135	3880	18.2	12.4	12.4	28	301	MR 9ML ZZ
M3 x 3.0	1.3	2.2	3.3	1570	2495	11.7	6.4	6.4	18	301	MR 9MN ZZ
M2 x 2.5	1.1	1.6	2.8	1310	2440	9	7.7	7.7	14	215	MR 7ML ZZ
M2 x 2.5	1.1	1.6	2.8	890	1400	5.2	3.3	3.3	8	215	MR 7MN ZZ
M2.6 x 2.0	0.7	1.3	2	470	900	2.4	2.1	2.1	4	116	MR 5ML ZZ
M2 x 1.5	0.7	1.3	2	335	550	1.7	1	1	3.5	116	MR 5MN ZZ
M2 x 1.1	0.3	0.7	1.5	295	575	0.9	1.1	1.1	1.2	53	MRU 3ML ZZ
M1.6 x 1.1	0.3	0.7	1.5	190	310	0.6	0.4	0.4	0.9	53	MRU 3MN ZZ

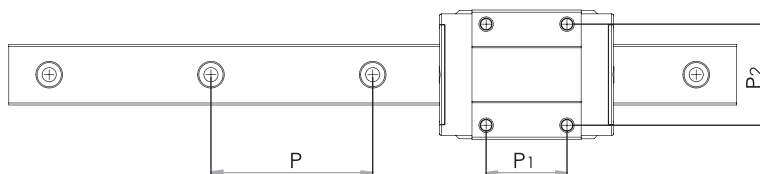

5. Dimensions and Specification

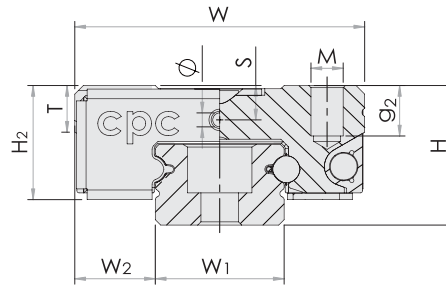

5.3 Standard MR-M EE series

Model Code	Fabricate Dimensions		Rail Dimensions (mm)				Block Dimensions (mm)					
	H	W ₂	W ₁	H ₁	P	D×d×g ₁	W	L	L ₁	H ₂	P ₁	P ₂
MR 15ML EE	16	8.5	15	9.5	40	6 × 3.5 × 4.5	32	61.6	44	12.8	25	25
MR 15MN EE	16	8.5	15	9.5	40	6 × 3.5 × 4.5	32	44.6	27	12.8	20	25
MR 12ML EE	13	7.5	12	7.5	25	6 × 3.5 × 4.5	27	49	34	10.7	20	20
MR 12MN EE	13	7.5	12	7.5	25	6 × 3.5 × 4.5	27	36.8	22	10.7	15	20
MR 9ML EE	10	5.5	9	5.5	20	6 × 3.5 × 3.5	20	41.9	30.8	8.3	16	15
MR 9MNEE	10	5.5	9	5.5	20	6 × 3.5 × 3.5	20	31.6	20.5	8.3	10	15
MR 5ML EE	6	3.5	5	3.5	15	3.5 × 2.4 × 1	12	20.2	13.5	4.9	7	–
MR 5MNEE	6	3.5	5	3.5	15	3.5 × 2.4 × 1	12	16.6	10	4.9	–	8

5.4 Standard MR-M EZ series

Model Code	Fabricate Dimensions		Rail Dimensions (mm)				Block Dimensions (mm)					
	H	W ₂	W ₁	H ₁	P	D×d×g ₁	W	L	L ₁	H ₂	P ₁	P ₂
MR 15ML EZ	16	8.5	15	9.5	40	6 × 3.5 × 4.5	32	61.6	44	12.8	25	25
MR 15MNEZ	16	8.5	15	9.5	40	6 × 3.5 × 4.5	32	44.6	27	12.8	20	25
MR 12ML EZ	13	7.5	12	7.5	25	6 × 3.5 × 4.5	27	49	34	10.7	20	20
MR 12MNEZ	13	7.5	12	7.5	25	6 × 3.5 × 4.5	27	36.8	22	10.7	15	20
MR 9ML EZ	10	5.5	9	5.5	20	6 × 3.5 × 3.5	20	41.9	30.8	8.3	16	15
MR 9MNEZ	10	5.5	9	5.5	20	6 × 3.5 × 3.5	20	31.6	20.5	8.3	10	15
MR 5ML EZ	6	3.5	5	3.5	15	3.5 × 2.4 × 1	12	20.2	13.5	4.9	7	–
MR 5MNEZ	6	3.5	5	3.5	15	3.5 × 2.4 × 1	12	16.6	10	4.9	–	8

Load capacities are calculated according to ISO 14728. Compare the rating life definition and the load capacities: $C_{508} = 1.26 \times C_{1008}$

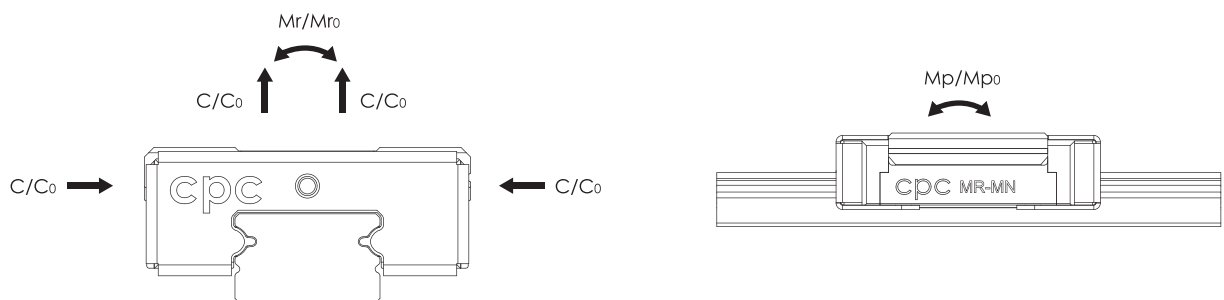

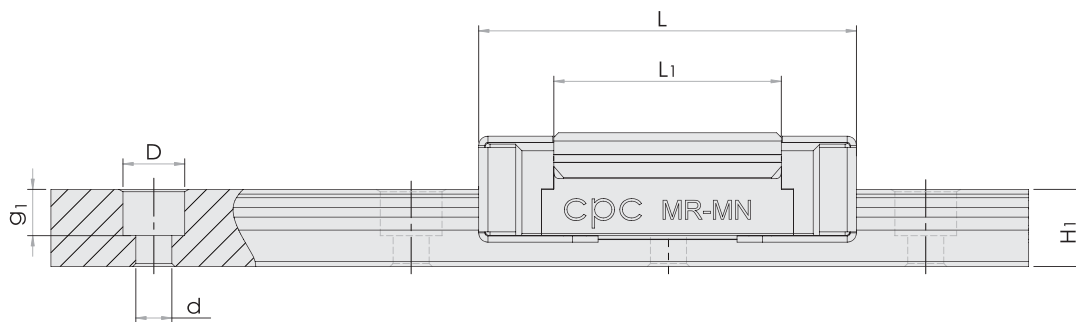

Block Dimensions (mm)				Load Capacities (N)		Static Moment (Nm)			Weight		Model Code
M×g ₂	Ø	S	T	C _{100B} (dyn)	Co(stat)	Mr ₀	Mp ₀	My ₀	Block(g)	Rail(g/m)	
M3 x 5.5	1.8	3.3	4.3	5350	9080	70	63.3	63.3	93	930	MR 15ML EE
M3 x 5.5	1.8	3.3	4.3	3810	5590	43.6	27	27	64	930	MR 15MN EE
M3 x 3.5	1.3	3.2	4.3	3240	5630	34.9	30.2	30.2	54	602	MR 12ML EE
M3 x 3.5	1.3	3.2	4.3	2308	3465	21.5	12.9	12.9	37	602	MR 12MN EE
M3 x 3.0	1.3	2.2	3.3	2135	3880	18.2	12.4	12.4	28	301	MR 9ML EE
M3 x 3.0	1.3	2.2	3.3	1570	2495	11.7	6.4	6.4	18	301	MR 9MN EE
M2.6 x 2.0	0.7	1.3	2	470	900	2.4	2.1	2.1	4	116	MR 5ML EE
M2 x 1.5	0.7	1.3	2	335	550	1.7	1	1	3.5	116	MR 5MNEE

Block Dimensions (mm)				Load Capacities (N)		Static Moment (Nm)			Weight		Model Code
M×g ₂	Ø	S	T	C _{100B} (dyn)	Co(stat)	Mr ₀	Mp ₀	My ₀	Block(g)	Rail(g/m)	
M3 x 5.5	1.8	3.3	4.3	5350	9080	70	63.3	63.3	93	930	MR 15ML EZ
M3 x 5.5	1.8	3.3	4.3	3810	5590	43.6	27	27	64	930	MR 15MN EZ
M3 x 3.5	1.3	3.2	4.3	3240	5630	34.9	30.2	30.2	54	602	MR 12ML EZ
M3 x 3.5	1.3	3.2	4.3	2308	3465	21.5	12.9	12.9	37	602	MR 12MN EZ
M3 x 3.0	1.3	2.2	3.3	2135	3880	18.2	12.4	12.4	28	301	MR 9ML EZ
M3 x 3.0	1.3	2.2	3.3	1570	2495	11.7	6.4	6.4	18	301	MR 9MN EZ
M2.6 x 2.0	0.7	1.3	2	470	900	2.4	2.1	2.1	4	116	MR 5ML EZ
M2 x 1.5	0.7	1.3	2	335	550	1.7	1	1	3.5	116	MR 5MNEZ

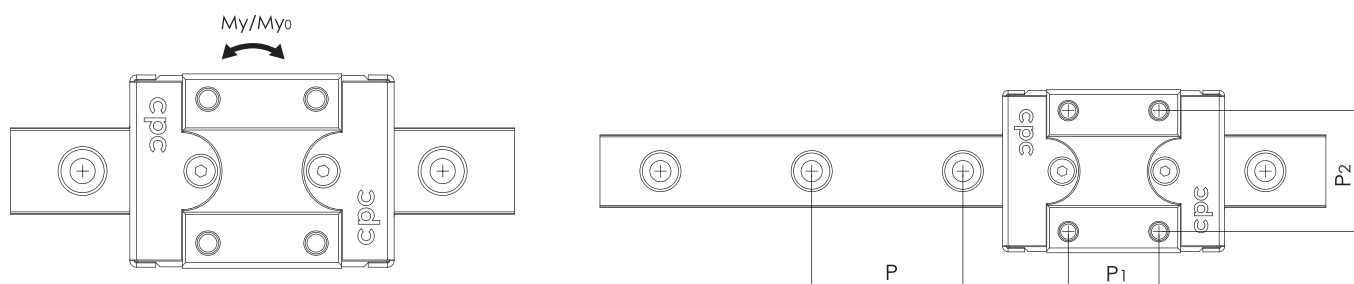

5. Dimensions and Specification

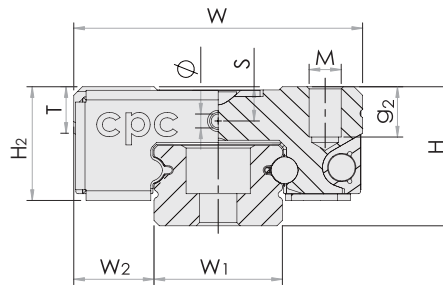

5.5 Standard MR-M EU series

Model Code	Fabricate Dimensions		Rail Dimensions (mm)				Block Dimensions (mm)					
	H	W ₂	W ₁	H ₁	P	D×d×g ₁	W	L	L ₁	H ₂	P ₁	P ₂
MR 15ML EU	16	8.5	15	9.5	40	6 x 3.5 x 4.5	32	61.6	44	13.1	25	25
MR 15MNEU	16	8.5	15	9.5	40	6 x 3.5 x 4.5	32	44.6	27	13.1	20	25
MR 12ML EU	13	7.5	12	7.5	25	6 x 3.5 x 4.5	27	49	34	11	20	20
MR 12MNEU	13	7.5	12	7.5	25	6 x 3.5 x 4.5	27	36.8	22	11	15	20
MR 9ML EU	10	5.5	9	5.5	20	6 x 3.5 x 3.5	20	41.9	30.8	8.6	16	15
MR 9MNEU	10	5.5	9	5.5	20	6 x 3.5 x 3.5	20	31.6	20.5	8.6	10	15

5.6 Standard MR-M UZ series

Model Code	Fabricate Dimensions		Rail Dimensions (mm)				Block Dimensions (mm)					
	H	W ₂	W ₁	H ₁	P	D×d×g ₁	W	L	L ₁	H ₂	P ₁	P ₂
MR 15MLUZ	16	8.5	15	9.5	40	6 x 3.5 x 4.5	32	61.6	44	13.1	25	25
MR 15MNUZ	16	8.5	15	9.5	40	6 x 3.5 x 4.5	32	44.6	27	13.1	20	25
MR 12MLUZ	13	7.5	12	7.5	25	6 x 3.5 x 4.5	27	49	34	11	20	20
MR 12MNUZ	13	7.5	12	7.5	25	6 x 3.5 x 4.5	27	36.8	22	11	15	20
MR 9MLUZ	10	5.5	9	5.5	20	6 x 3.5 x 3.5	20	41.9	30.8	8.6	16	15
MR 9MNUZ	10	5.5	9	5.5	20	6 x 3.5 x 3.5	20	31.6	20.5	8.6	10	15

Load capacities are calculated according to ISO 14728, Compare the rating life definition and the load capacities: $C_{50B} = 1.26 \times C_{100B}$

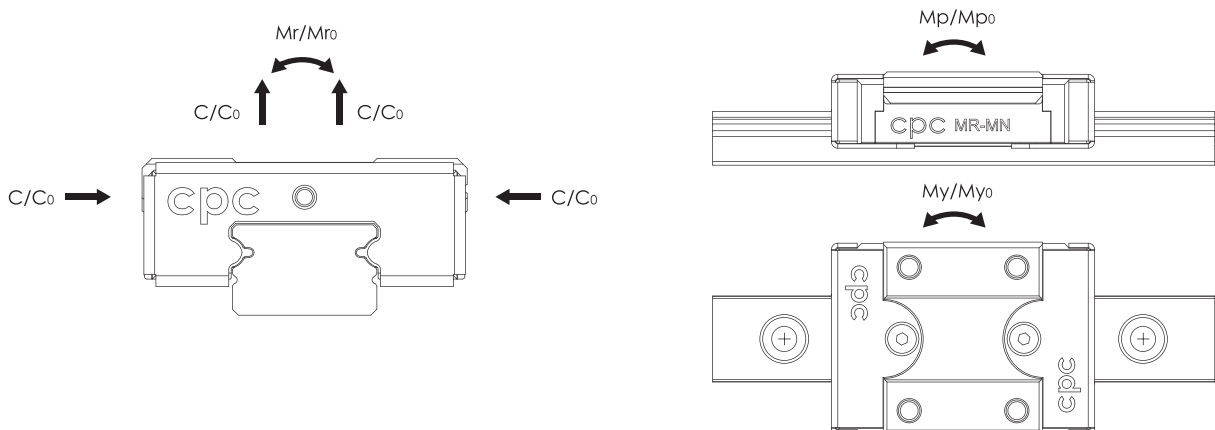

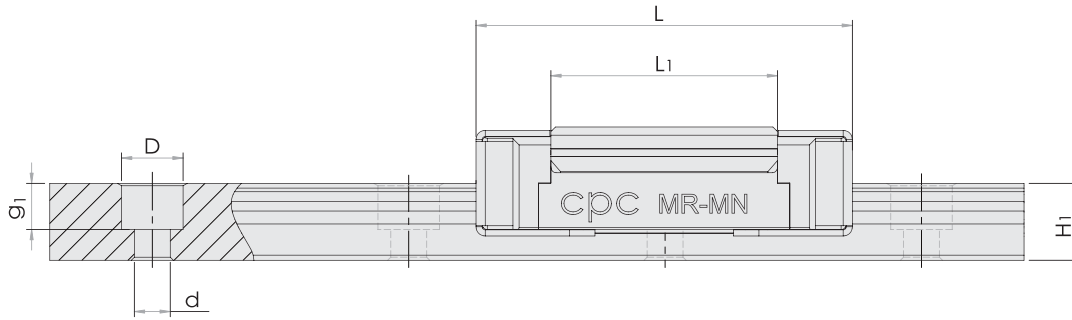

Block Dimensions (mm)				Load Capacities (N)		Static Moment (Nm)			Weight		Model Code
M×g ₂	∅	S	T	C _{100B} (dyn)	C ₀ (stat)	M _{r0}	M _{p0}	M _{y0}	Block(g)	Rail(g/m)	
M3 x 5.5	1.8	3.3	4.3	5350	9080	70	63.3	63.3	93	930	MR 15ML EU
M3 x 5.5	1.8	3.3	4.3	3810	5590	43.6	27	27	64	930	MR 15MN EU
M3 x 3.5	1.3	3.2	4.3	3240	5630	34.9	30.2	30.2	54	602	MR 12ML EU
M3 x 3.5	1.3	3.2	4.3	2308	3465	21.5	12.9	12.9	37	602	MR 12MN EU
M3 x 3.0	1.3	2.2	3.3	2135	3880	18.2	12.4	12.4	28	301	MR 9ML EU
M3 x 3.0	1.3	2.2	3.3	1570	2495	11.7	6.4	6.4	18	301	MR 9MN EU

Block Dimensions (mm)				Load Capacities (N)		Static Moment (Nm)			Weight		Model Code
M×g ₂	∅	S	T	C _{100B} (dyn)	C ₀ (stat)	M _{r0}	M _{p0}	M _{y0}	Block(g)	Rail(g/m)	
M3 x 5.5	1.8	3.3	4.3	5350	9080	70	63.3	63.3	93	930	MR 15ML UZ
M3 x 5.5	1.8	3.3	4.3	3810	5590	43.6	27	27	64	930	MR 15MNUZ
M3 x 3.5	1.3	3.2	4.3	3240	5630	34.9	30.2	30.2	54	602	MR 12ML UZ
M3 x 3.5	1.3	3.2	4.3	2308	3465	21.5	12.9	12.9	37	602	MR 12MNUZ
M3 x 3.0	1.3	2.2	3.3	2135	3880	18.2	12.4	12.4	28	301	MR 9ML UZ
M3 x 3.0	1.3	2.2	3.3	1570	2495	11.7	6.4	6.4	18	301	MR 9MNUZ

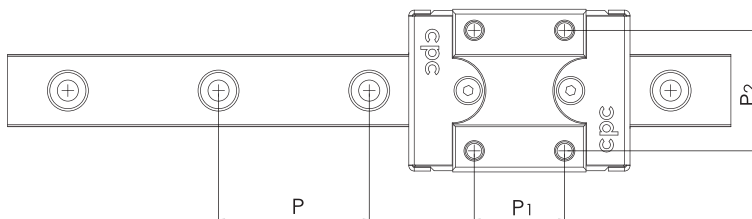

5. Dimensions and Specification

5.7 Wide MR-W SS series

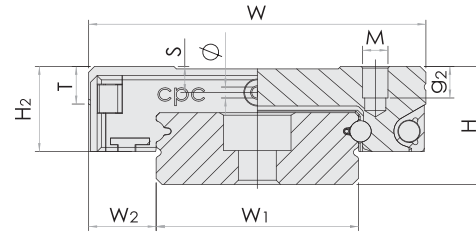

MR 3W-MR 12W

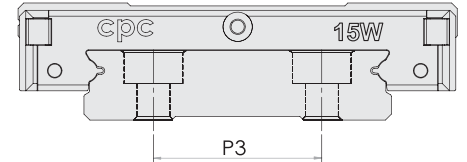

MR 15W

Model Code	Fabricate Dimensions		Rail Dimensions (mm)					Block Dimensions (mm)					
	H	W ₂	W ₁	H ₁	P	P ₃	D×d×g ₁	W	L	L ₁	H ₂	P ₁	P ₂
MR 15WL SS	16	9	42	9.5	40	23	8 × 4.5 × 4.5	60	74.4	57.6	12	35	45
MR 15WN SS	16	9	42	9.5	40	23	8 × 4.5 × 4.5	60	55.3	38.5	12	20	45
MR 12WL SS	14	8	24	8.5	40	–	8 × 4.5 × 4.5	40	59.4	46	10.1	28	28
MR 12WN SS	14	8	24	8.5	40	–	8 × 4.5 × 4.5	40	44.4	31	10.1	15	28
MR 9WL SS	12	6	18	7.3	30	–	6 × 3.5 × 4.5	30	50.7	39.5	8.6	24	23
MR 9WN SS	12	6	18	7.3	30	–	6 × 3.5 × 4.5	30	39.1	27.9	8.6	12	21
MR 7WL SS	9	5.5	14	5.2	30	–	6 × 3.5 × 3.5	25	40.5	30.1	7	19	19
MR 7WN SS	9	5.5	14	5.2	30	–	6 × 3.5 × 3.5	25	31.6	21.2	7	10	19
MR 5WL SS	6.5	3.5	10	4	20	–	5.5 × 3 × 1.6	17	27.2	21.2	5	11	13
MR 5WLC SS	6.5	3.5	10	4	20	–	5.5 × 3 × 1.6	17	27.2	21.2	5	11	13
MR 5WN SS	6.5	3.5	10	4	20	–	5.5 × 3 × 1.6	17	21.1	15.1	5	6.5	13
MR 5WNC SS	6.5	3.5	10	4	20	–	5.5 × 3 × 1.6	17	21.1	15.1	5	6.5	13
MR 3WL SS	4.5	3	6	2.7	15	–	4 × 2.4 × 1.5	12	20.1	15.1	3.5	8	–
MR 3WN SS	4.5	3	6	2.7	15	–	4 × 2.4 × 1.5	12	15	10	3.5	4.5	–
MR 2WL SS	4	3	4	3	10	–	2.8 × 2.4 × 0.75	10	17	11.9	3	6.5	–

Load capacities are calculated according to ISO 14728. Compare the rating life definition and the load capacities: $C_{50B} = 1.26 \times C_{100B}$

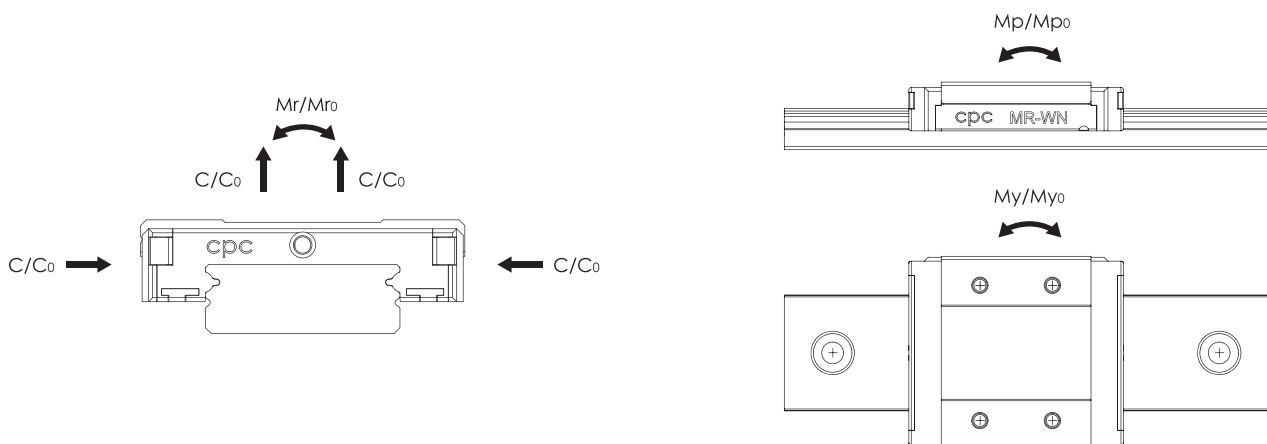

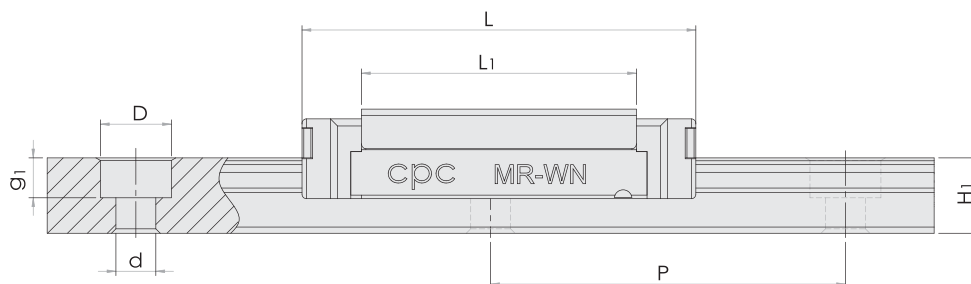

Block Dimensions (mm)				Load Capacities (N)		Static Moment (Nm)			Weight		Model Code
M×g ₂	∅	S	T	C _{100B} (dyn)	C ₀ (stat)	M _{r0}	M _{p0}	M _{y0}	Block(g)	Rail(g/m)	
M4 x 4.5	1.8	3.3	4.5	6725	12580	257.6	93.1	93.1	200	2818	MR 15WL SS
M4 x 4.5	1.8	3.3	4.5	5065	8385	171.7	45.7	45.7	137	2818	MR 15WN SS
M3 x 3.5	1.3	3.1	4.5	4070	7800	95.6	56.4	56.4	93	1472	MR 12WL SS
M3 x 3.5	1.3	3.1	4.5	3065	5200	63.7	26.3	26.3	65	1472	MR 12WN SS
M3 x 3	1.3	2.6	4	2550	4990	45.9	26.7	26.7	51	940	MR 9WL SS
M3 x 3	1.3	2.6	4	2030	3605	33.2	13.7	13.7	37	940	MR 9WN SS
M3 x 3	1.1	1.9	3.2	1570	3140	22.65	14.9	14.9	27	516	MR 7WL SS
M3 x 3	1.1	1.9	3.2	1180	2095	15	7.3	7.3	19	516	MR 7WN SS
M2.5 x 1.5	0.9	1.2	2.3	615	1315	6.8	4.1	4.1	8	280	MR 5WL SS
M3/M2.5 x 1.5	0.9	1.2	2.3	615	1315	6.8	4.1	4.1	8	280	MR 5WLC SS
M2.5 x 1.5	0.9	1.2	2.3	475	900	4.6	2.2	2.2	6	280	MR 5WN SS
M3/M2.5 x 1.5	0.9	1.2	2.3	475	900	4.6	2.2	2.2	6	280	MR 5WNC SS
M2 x 1.4	0.3	0.8	1.8	370	800	2.5	1.9	1.9	3.4	105	MR 3WL SS
M2 x 1.4	0.3	0.8	1.8	280	530	1.6	0.9	0.9	3.4	105	MR 3WN SS
M2 x 1.3	-	-	1.3	310	625	1.6	1.2	1.2	3.0	69	MR 2WL SS

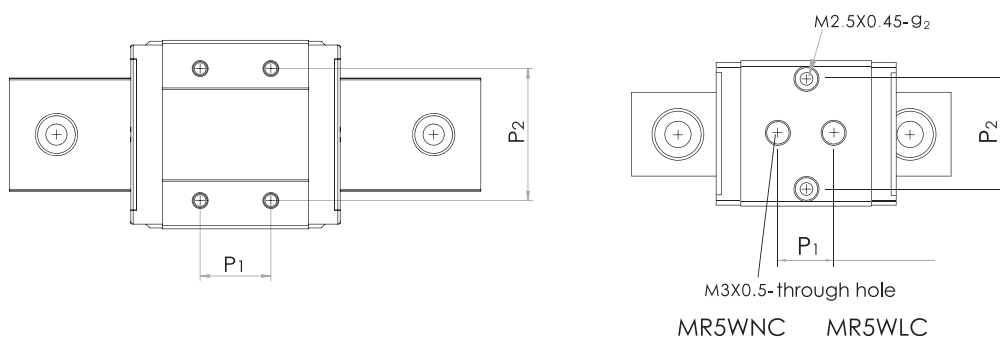

5. Dimensions and Specification

5.8 Wide MR-W ZZ series

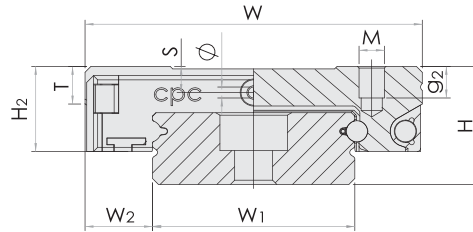

MR 3W-MR 12W

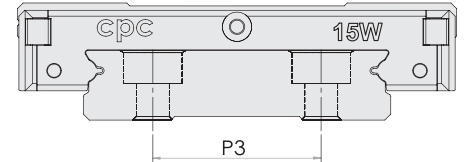

MR 15W

Model Code	Fabricate Dimensions		Rail Dimensions (mm)					Block Dimensions (mm)					
	H	W ₂	W ₁	H ₁	P	P ₃	D×d×g ₁	W	L	L ₁	H ₂	P ₁	P ₂
MR 15WL ZZ	16	9	42	9.5	40	23	8 x 4.5 x 4.5	60	74.4	57.6	12	35	45
MR 15WN ZZ	16	9	42	9.5	40	23	8 x 4.5 x 4.5	60	55.3	38.5	12	20	45
MR 12WL ZZ	14	8	24	8.5	40	–	8 x 4.5 x 4.5	40	59.4	46	10.1	28	28
MR 12WN ZZ	14	8	24	8.5	40	–	8 x 4.5 x 4.5	40	44.4	31	10.1	15	28
MR 9 WL ZZ	12	6	18	7.3	30	–	6 x 3.5 x 4.5	30	50.7	39.5	8.6	24	23
MR 9 WN ZZ	12	6	18	7.3	30	–	6 x 3.5 x 4.5	30	39.1	27.9	8.6	12	21
MR 7 WL ZZ	9	5.5	14	5.2	30	–	6 x 3.5 x 3.5	25	40.5	30.1	7	19	19
MR 7 WN ZZ	9	5.5	14	5.2	30	–	6 x 3.5 x 3.5	25	31.6	21.2	7	10	19
*MR 5 WL ZZ	6.5	3.5	10	4	20	–	5.5 x 3 x 1.6	17	27.2	21.2	5	11	13
*MR 5WLC ZZ	6.5	3.5	10	4	20	–	5.5 x 3 x 1.6	17	27.2	21.2	5	11	13
*MR 5 WN ZZ	6.5	3.5	10	4	20	–	5.5 x 3 x 1.6	17	21.1	15.1	5	6.5	13
*MR 5WNC ZZ	6.5	3.5	10	4	20	–	5.5 x 3 x 1.6	17	21.1	15.1	5	6.5	13
*MR 3 WL ZZ	4.5	3	6	2.7	15	–	4 x 2.4 x 1.5	12	20.1	15.1	3.5	8	–
*MR 3 WN ZZ	4.5	3	6	2.7	15	–	4 x 2.4 x 1.5	12	15	10	3.5	4.5	–
MR 2 WL ZZ	4	3	4	3	10	–	2.8 x 2.4 x 0.75	10	17	11.9	3	6.5	–

* Preparing

Load capacities are calculated according to ISO 14728. Compare the life rating definition and the load capacities: $C_{508}=1.26 \times C_{1008}$

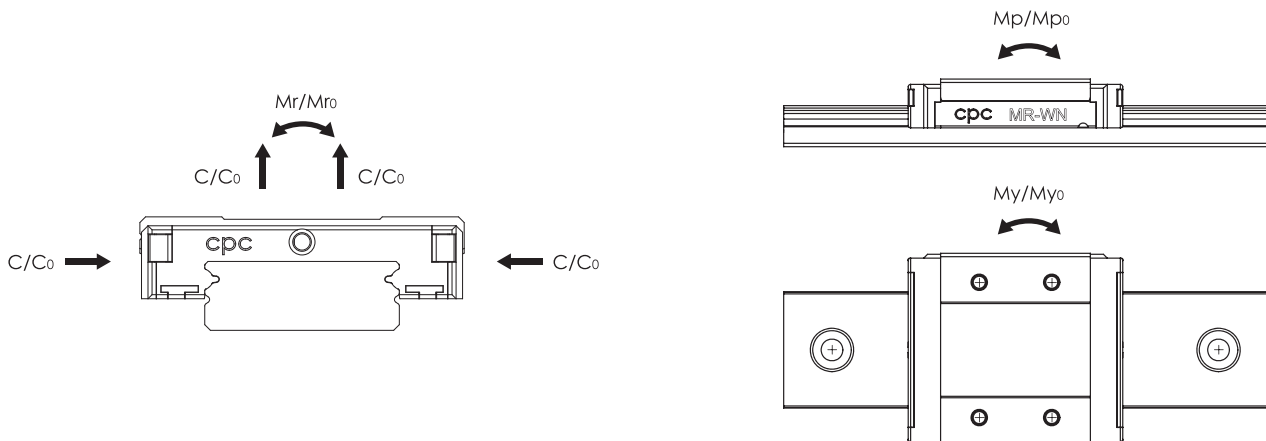

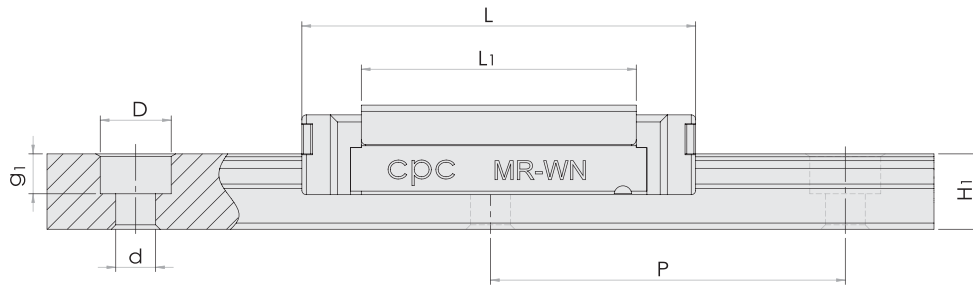

Block Dimensions (mm)				Load Capacities (N)		Static Moment (Nm)			Weight		Model Code
M×g ₂	Ø	S	T	C _{100B} (dyn)	C ₀ (stat)	M _{r0}	M _{p0}	M _{y0}	Block(g)	Rail(g/m)	
M4 x 4.5	1.8	3.3	4.5	6725	12580	257.6	93.1	93.1	200	2818	MR 15WL ZZ
M4 x 4.5	1.8	3.3	4.5	5065	8385	171.7	45.7	45.7	137	2818	MR 15WN ZZ
M3 x 3.5	1.3	3.1	4.5	4070	7800	95.6	56.4	56.4	93	1472	MR 12WL ZZ
M3 x 3.5	1.3	3.1	4.5	3065	5200	63.7	26.3	26.3	65	1472	MR 12WN ZZ
M3 x 3	1.3	2.6	4	2550	4990	45.9	26.7	26.7	51	940	MR 9 WL ZZ
M3 x 3	1.3	2.6	4	2030	3605	33.2	13.7	13.7	37	940	MR 9WN ZZ
M3 x 3	1.1	1.9	3.2	1570	3140	22.65	14.9	14.9	27	516	MR 7 WL ZZ
M3 x 3	1.1	1.9	3.2	1180	2095	15	7.3	7.3	19	516	MR 7WN ZZ
M2.5 x 1.5	0.9	1.2	2.3	615	1315	6.8	4.1	4.1	8	280	MR 5 WL ZZ
M3/M2.5 x 1.5	0.9	1.2	2.3	615	1315	6.8	4.1	4.1	8	280	MR 5WLC ZZ
M2.5 x 1.5	0.9	1.2	2.3	475	900	4.6	2.2	2.2	6	280	MR 5WN ZZ
M3/M2.5 x 1.5	0.9	1.2	2.3	475	900	4.6	2.2	2.2	6	280	MR 5WNC ZZ
M2 x 1.4	0.3	0.8	1.8	370	800	2.5	1.9	1.9	3.4	105	MR 3 WL ZZ
M2 x 1.4	0.3	0.8	1.8	280	530	1.6	0.9	0.9	3.4	105	MR 3WN ZZ
M2 x 1.3	-	-	1.3	310	625	1.6	1.2	1.2	3.0	69	MR 2 WL ZZ

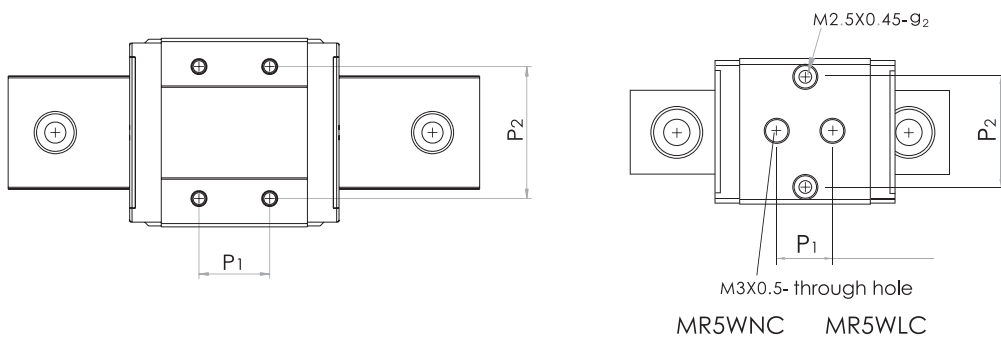

5. Dimensions and Specification

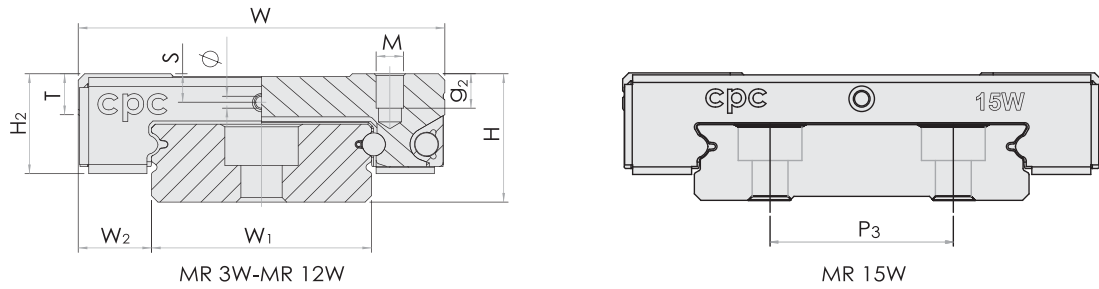

5.9 Wide MR-W EE series

Model Code	Fabricate Dimensions		Rail Dimensions (mm)					Block Dimensions (mm)					
	H	W ₂	W ₁	H ₁	P	P ₃	D×d×g ₁	W	L	L ₁	H ₂	P ₁	P ₂
MR 15WL EE	16	9	42	9.5	40	23	8 x 4.5 x 4.5	60	76	57.6	12.8	35	45
MR 15WN EE	16	9	42	9.5	40	23	8 x 4.5 x 4.5	60	56.9	38.5	12.8	20	45
MR 12WL EE	14	8	24	8.5	40	–	8 x 4.5 x 4.5	40	60.8	46	10.7	28	28
MR 12WN EE	14	8	24	8.5	40	–	8 x 4.5 x 4.5	40	45.8	31	10.7	15	28
MR 9 WL EE	12	6	18	7.3	30	–	6 x 3.5 x 4.5	30	51.8	39.5	9.2	24	23
MR 9 WN EE	12	6	18	7.3	30	–	6 x 3.5 x 4.5	30	40.2	27.9	9.2	12	21
MR 7 WL EE	9	5.5	14	5.2	30	–	6 x 3.5 x 3.5	25	41.5	30.1	7.5	19	19
MR 7 WN EE	9	5.5	14	5.2	30	–	6 x 3.5 x 3.5	25	32.5	21.2	7.5	10	19
MR 2 WL EE	4	3	4	3	10	–	2.8 x 2.4 x 0.75	10	17.5	11.9	3.3	6.5	–

5.10 Wide MR-W EZ series

Model Code	Fabricate Dimensions		Rail Dimensions (mm)					Block Dimensions (mm)					
	H	W ₂	W ₁	H ₁	P	P ₃	D×d×g ₁	W	L	L ₁	H ₂	P ₁	P ₂
MR 15WL EZ	16	9	42	9.5	40	23	8 x 4.5 x 4.5	60	76	57.6	12.8	35	45
MR 15WN EZ	16	9	42	9.5	40	23	8 x 4.5 x 4.5	60	56.9	38.5	12.8	20	45
MR 12WL EZ	14	8	24	8.5	40	–	8 x 4.5 x 4.5	40	60.8	46	10.7	28	28
MR 12WN EZ	14	8	24	8.5	40	–	8 x 4.5 x 4.5	40	45.8	31	10.7	15	28
MR 9 WL EZ	12	6	18	7.3	30	–	6 x 3.5 x 4.5	30	51.8	39.5	9.2	24	23
MR 9 WN EZ	12	6	18	7.3	30	–	6 x 3.5 x 4.5	30	40.2	27.9	9.2	12	21
MR 7 WL EZ	9	5.5	14	5.2	30	–	6 x 3.5 x 3.5	25	41.5	30.1	7.5	19	19
MR 7 WN EZ	9	5.5	14	5.2	30	–	6 x 3.5 x 3.5	25	32.5	21.2	7.5	10	19
MR 2 WL EZ	4	3	4	3	10	–	2.8 x 2.4 x 0.75	10	17.5	11.9	3.3	6.5	–

Load capacities are calculated according to ISO 14728, Compare the rating life definition and the load capacities: $C_{50B} = 1.26 \times C_{100B}$

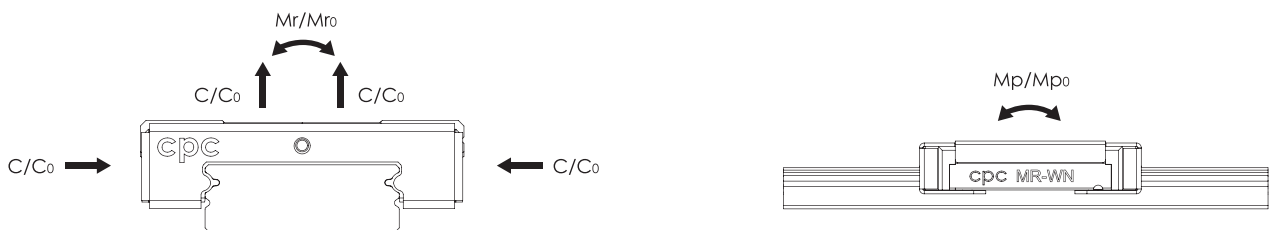

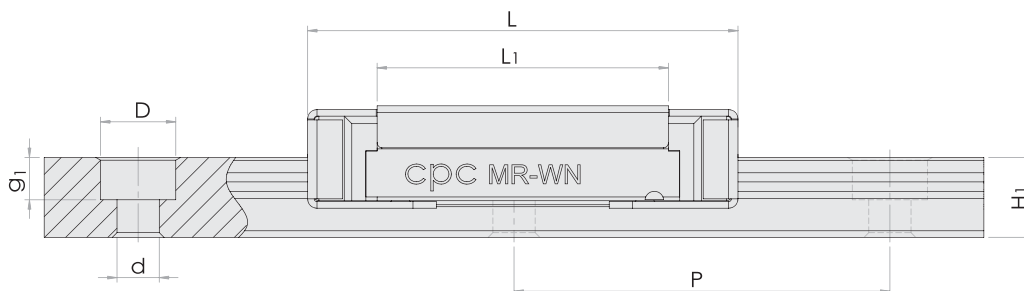

Block Dimensions (mm)				Load Capacities (N)		Static Moment (Nm)			Weight		Model Code
M×g ₂	∅	S	T	C _{100B} (dyn)	C ₀ (stat)	M _{r0}	M _{p0}	M _{y0}	Block(g)	Rail(g/m)	
M4 x 4.5	1.8	3.3	4.5	6725	12580	257.6	93.1	93.1	203	2818	MR 15WL EE
M4 x 4.5	1.8	3.3	4.5	5065	8385	171.7	45.7	45.7	140	2818	MR 15WN EE
M3 x 3.5	1.3	3.1	4.5	4070	7800	95.6	56.4	56.4	96	1472	MR 12WL EE
M3 x 3.5	1.3	3.1	4.5	3065	5200	63.7	26.3	26.3	68	1472	MR 12WN EE
M3 x 3	1.3	2.6	4	2550	4990	45.9	26.7	26.7	51	940	MR 9 WL EE
M3 x 3	1.3	2.6	4	2030	3605	33.2	13.7	13.7	37	940	MR 9 WN EE
M3 x 3	1.1	1.9	3.2	1570	3140	22.65	14.9	14.9	27	516	MR 7 W L EE
M3 x 3	1.1	1.9	3.2	1180	2095	15	7.3	7.3	19	516	MR 7 WN EE
M2 x 1.3	-	-	1.3	310	625	1.6	1.2	1.2	3.0	69	MR 2 W L EE

Block Dimensions (mm)				Load Capacities (N)		Static Moment (Nm)			Weight		Model Code
M×g ₂	∅	S	T	C _{100B} (dyn)	C ₀ (stat)	M _{r0}	M _{p0}	M _{y0}	Block(g)	Rail(g/m)	
M4 x 4.5	1.8	3.3	4.5	6725	12580	257.6	93.1	93.1	203	2818	MR 15WL EZ
M4 x 4.5	1.8	3.3	4.5	5065	8385	171.7	45.7	45.7	140	2818	MR 15WN EZ
M3 x 3.5	1.3	3.1	4.5	4070	7800	95.6	56.4	56.4	96	1472	MR 12WL EZ
M3 x 3.5	1.3	3.1	4.5	3065	5200	63.7	26.3	26.3	68	1472	MR 12WN EZ
M3 x 3	1.3	2.6	4	2550	4990	45.9	26.7	26.7	51	940	MR 9 WL EZ
M3 x 3	1.3	2.6	4	2030	3605	33.2	13.7	13.7	37	940	MR 9 W N EZ
M3 x 3	1.1	1.9	3.2	1570	3140	22.65	14.9	14.9	27	516	MR 7 WL EZ
M3 x 3	1.1	1.9	3.2	1180	2095	15	7.3	7.3	19	516	MR 7 WN EZ
M2 x 1.3	-	-	1.3	310	625	1.6	1.2	1.2	3.0	69	MR 2 WL EZ

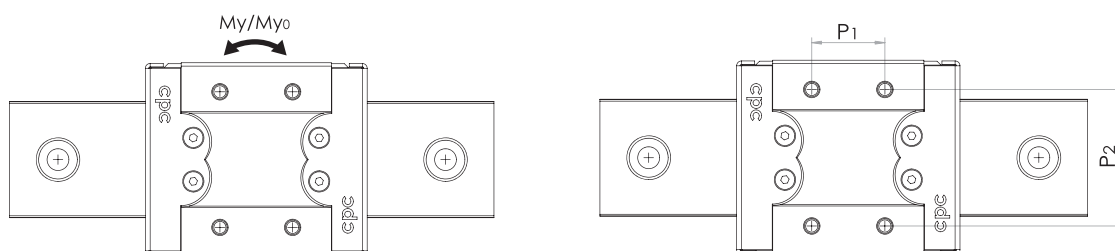

5. Dimensions and Specification

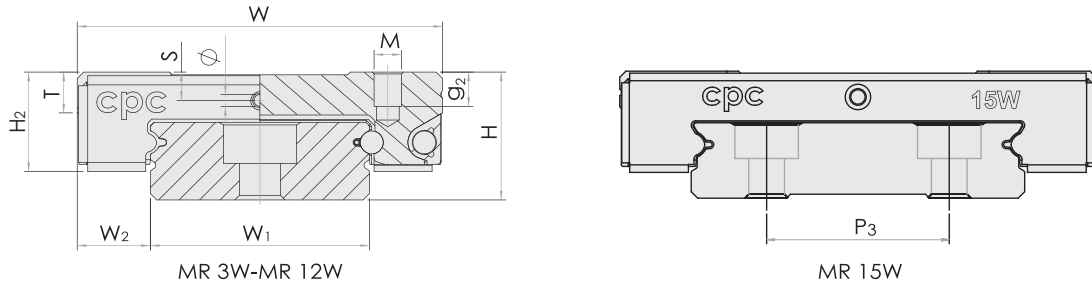

5.11 Wide MR-W EU series

Model Code	Fabricate Dimensions		Rail Dimensions (mm)					Block Dimensions (mm)					
	H	W ₂	W ₁	H ₁	P	P ₃	D×d×g ₁	W	L	L ₁	H ₂	P ₁	P ₂
MR 15WL EU	16	9	42	9.5	40	23	8 x 4.5 x 4.5	60	76	57.6	13.1	35	45
MR 15WN EU	16	9	42	9.5	40	23	8 x 4.5 x 4.5	60	56.9	38.5	13.1	20	45
MR 12WL EU	14	8	24	8.5	40	–	8 x 4.5 x 4.5	40	60.8	46	11	28	28
MR 12WN EU	14	8	24	8.5	40	–	8 x 4.5 x 4.5	40	45.8	31	11	15	28
MR 9WL EU	12	6	18	7.3	30	–	6 x 3.5 x 4.5	30	51.8	39.5	9.5	24	23
MR 9WN EU	12	6	18	7.3	30	–	6 x 3.5 x 4.5	30	40.2	27.9	9.5	12	21

5.12 Wide MR-W UZ series

Model Code	Fabricate Dimensions		Rail Dimensions (mm)					Block Dimensions (mm)					
	H	W ₂	W ₁	H ₁	P	P ₃	D×d×g ₁	W	L	L ₁	H ₂	P ₁	P ₂
MR 15WL UZ	16	9	42	9.5	40	23	8 x 4.5 x 4.5	60	76	57.6	13.1	35	45
MR 15WN UZ	16	9	42	9.5	40	23	8 x 4.5 x 4.5	60	56.9	38.5	13.1	20	45
MR 12WL UZ	14	8	24	8.5	40	–	8 x 4.5 x 4.5	40	60.8	46	11	28	28
MR 12WN UZ	14	8	24	8.5	40	–	8 x 4.5 x 4.5	40	45.8	31	11	15	28
MR 9WL UZ	12	6	18	7.3	30	–	6 x 3.5 x 4.5	30	51.8	39.5	9.5	24	23
MR 9WN UZ	12	6	18	7.3	30	–	6 x 3.5 x 4.5	30	40.2	27.9	9.5	12	21

Load capacities are calculated according to ISO 14728, Compare the rating life definition and the load capacities: $C_{50B}=1.26 \times C_{100B}$

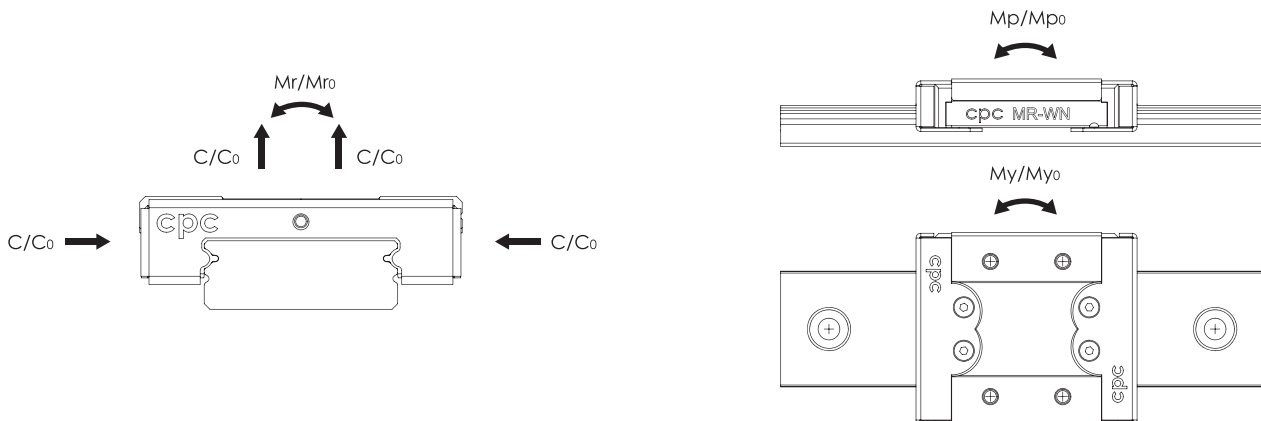

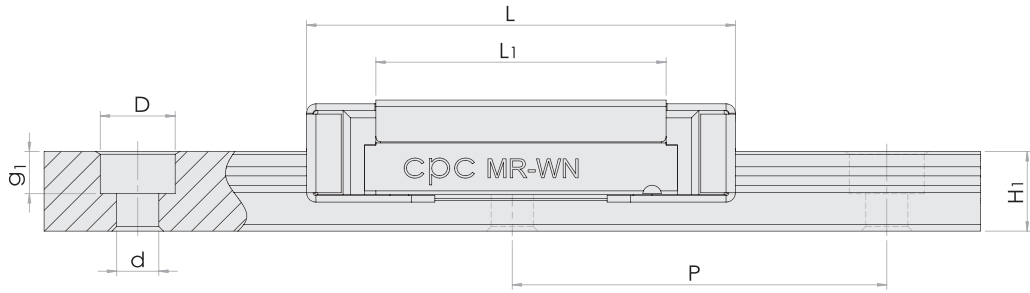

Block Dimensions (mm)				Load Capacities (N)		Static Moment (Nm)			Weight		Model Code
M×g ₂	∅	S	T	C _{100B} (dyn)	C ₀ (stat)	M _{r0}	M _{p0}	M _{y0}	Block(g)	Rail(g/m)	
M4 x 4.5	1.8	3.3	4.5	6725	12580	257.6	93.1	93.1	203	2818	MR 15WL EU
M4 x 4.5	1.8	3.3	4.5	5065	8385	171.7	45.7	45.7	140	2818	MR 15WN EU
M3 x 3.5	1.3	3.1	4.5	4070	7800	95.6	56.4	56.4	96	1472	MR 12WL EU
M3 x 3.5	1.3	3.1	4.5	3065	5200	63.7	26.3	26.3	68	1472	MR 12WN EU
M3 x 3	1.3	2.6	4	2550	4990	45.9	26.7	26.7	51	940	MR 9WL EU
M3 x 3	1.3	2.6	4	2030	3605	33.2	13.7	13.7	37	940	MR 9WN EU

Block Dimensions (mm)				Load Capacities (N)		Static Moment (Nm)			Weight		Model Code
M×g ₂	∅	S	T	C _{100B} (dyn)	C ₀ (stat)	M _{r0}	M _{p0}	M _{y0}	Block(g)	Rail(g/m)	
M4 x 4.5	1.8	3.3	4.5	6725	12580	257.6	93.1	93.1	203	2818	MR 15WL UZ
M4 x 4.5	1.8	3.3	4.5	5065	8385	171.7	45.7	45.7	140	2818	MR 15WN UZ
M3 x 3.5	1.3	3.1	4.5	4070	7800	95.6	56.4	56.4	96	1472	MR 12WL UZ
M3 x 3.5	1.3	3.1	4.5	3065	5200	63.7	26.3	26.3	68	1472	MR 12WN UZ
M3 x 3	1.3	2.6	4	2550	4990	45.9	26.7	26.7	51	940	MR 9WL UZ
M3 x 3	1.3	2.6	4	2030	3605	33.2	13.7	13.7	37	940	MR 9WN UZ

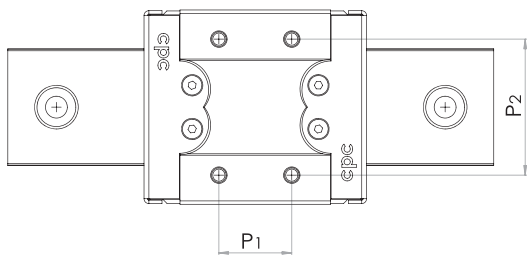

5. Dimensions and Specification

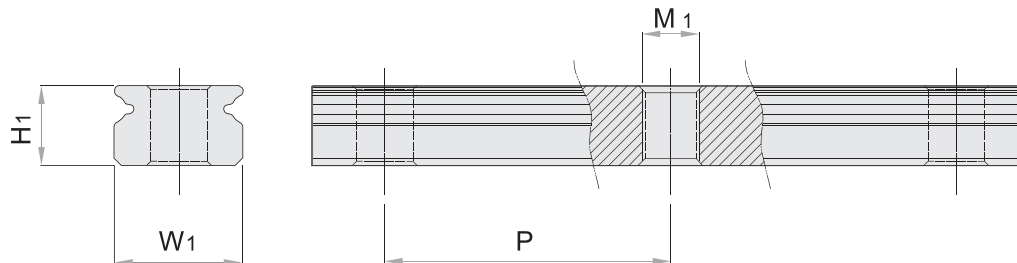

5.13 Upward Screwing Standard MRU-M series

Dimensions and Specification

Model Code	Rail Dimensions (mm)			
	H ₁	W ₁	P	M ₁
MRU 15M	9.5	15	40	M4x0.7
MRU 12M	7.5	12	25	M4x0.7
MRU 9M	5.5	9	20	M4x0.7
MRU 7M	4.7	7	15	M3x0.5
MRU 5M	3.5	5	15	M3x0.5
MRU 3M	2.6	3	10	M1.6 x0.35

5.14 Upward Screwing Wide MRU-W series

Dimensions and Specification

Model Code	Rail Dimensions (mm)			
	H ₁	W ₁	P	M ₁
MRU 15W	9.5	42	40	M5x0.8
MRU 12W	8.5	24	40	M5x0.8
MRU 9W	7.3	18	30	M4x0.7
MRU 7W	5.2	14	30	M4x0.7
MRU 5W	4	10	20	M3x0.5
MRU 3W	2.7	6	15	M3x0.5



ST Miniature Stroke Slide series

1. Products Introduction

High load and high moment capacity

ST Miniature Stroke Slide series incorporate with the design of two rows of ball, The ball track has Gothic profile design with 45 degree contact angle to attain the effect of equal load capacity in all mono block provide more space for the larger rolling elements, enhance the load and moment capacity.

High running accuracy and smoothness

The steel balls of ST Miniature Stroke Slide series roll on the rail without recirculation; such brings an excellent running behavior, smoothness, low fiction, and high accuracy. Without vibration.

Temperature

ST Miniature Stroke Slide series can stand the temperature up to 150°C. There are two options for higher temperature application:
T1 : 200°C
T2 : 300°C
Treated with higher temperature will reduce the load capacity.



Double side pair block plate design

ST Miniature Stroke Slide series adopt pair block plate designing, both rail and block terminal surface sides all install block plates, can prevent inear guide from pass stroke situation effectively.



Easy mounting

The mounting of the ST Miniature Stroke Slide series in all length can be fulfilled by fitting the fixing screw downward into the count bore of the rail by intersecting the bore pattern on the block and cage within a hole pitch movement of side. The one piece cage therefore does not influent the mounting of the rail.

The preload is preset by ball sorting.

Anti-corrosion feature

ST Miniature Stroke Slide series material use the quenched hardened process Stainless steel for the rail, block and Steel Balls. The block plate and screw ls made by stainless steel also. Easy for maintenance and check.

2. Technical Information

Accuracy

The ST Miniature Stroke Slide series have three grades for accuracy. Precision (P), High (H) and Normal (N).

Preload

The ST miniature stroke slide series have three classes of preload V0 and V1 as described in the MR miniature linear guide series table of preload.

Rating life calculation

$$L = K_{st} \left(\frac{C_{100B}}{P} \right)^3 \cdot 10^5 \quad \text{--- (19)}$$

$$L_h = \frac{L}{2 \cdot s \cdot n \cdot 60} = K_{st} \frac{L}{v_m} \cdot \left(\frac{C_{100B}}{P} \right)^3 \quad \text{--- (20)}$$

Short stroke factor diagram

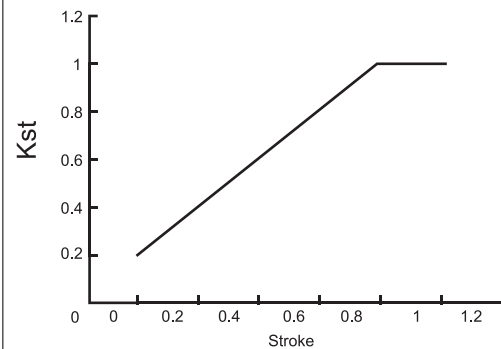

According to ISO14728-1 short stroke factor

Lubrication

The lubrication of ST Miniature Stroke Slide series can be fulfilled by adding the lubricant onto the raceway of the rail.

Rating life L

The rating life of ST miniature stroke slide series can be calculated by the formulas (19) , (20) in accordance with ISO 14728-1.



Geometric and positional accuracy of the mounting surface

The inaccuracy of the mounting surfaces will affect the running accuracy and reduce the operating life time of the ST Miniature Stroke Slide. If the inaccuracies of the mounting surfaces exceed the values calculated by formulas (15), (21), and (17), the life time will become shortened, as calculated by formulas (19) and (20).

$$e_1(\text{mm}) = b(\text{mm}) \cdot f_1 \cdot 10^{-4} \quad \text{--- (15)}$$

$$e_2(\text{mm}) = \left(\frac{d}{L_C}\right) \cdot f_2 \cdot 10^{-5} \quad \text{--- (21)}$$

$$e_3(\text{mm}) = f_3 \cdot 10^{-3} \quad \text{--- (17)}$$

Size	V0			V1			Ordering Designation
	f1	f2	f3	f1	f2	f3	
7	5	200	4	3	130	3	<p>Ordering Designation</p> <p>ST 7 M V0 P 27 / 30 x 30 To</p> <p>Stroke type: ST</p> <p>Size: 7</p> <p>M: Standard W: Wide</p> <p>V0: Clearance V1: Light preload</p> <p>P: Normal H: High P: Precision</p> <p>Max stroke (mm): 27</p> <p>Block L1 length (mm): 30</p> <p>Rail Lr length (mm): 30</p> <p>Max temperature°C T0:150 T1:200 T2:300</p>
9	5	300	6	4	200	4	
12	6	380	8	4	250	6	
15	7	530	12	5	350	8	

Height and chamfered the reference edge

The tables for the chamfered the reference edge corner and the height of reference edge shown on MR Miniature Linear Guide series are also suitable for the ST Miniature Stroke Slide series.

3. Order Information

An example of the ST miniature stroke slide series parts numbering system is shown in the above ordering designation.

4. Dimensions and Specification

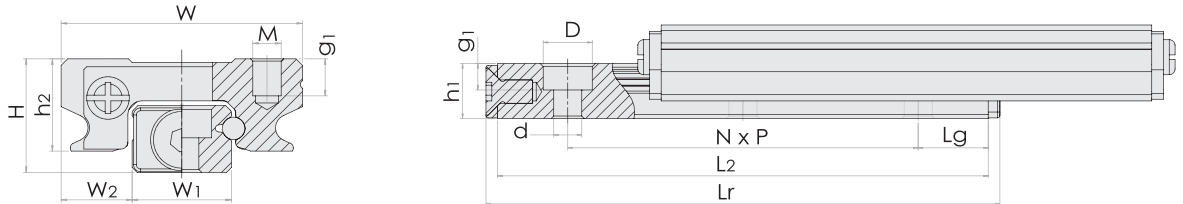

Model Code	Fabricate Dimensions (mm)		Rail Dimensions (mm)			
	H	W ₂	P	W ₁	h ₁	D x d x g ₁
ST7M	8	5	15	7	4.7	4.2x2.4x2.3
ST9M	10	5.5	20	9	5.5	6x3.5x3.5
ST12M	13	7.5	25	12	7.5	6x3.5x4.5

Model Code	Max Stroke	Rail Dimensions (mm)					Lb	
	Ls	Lr	L ₂	Lg	N			
ST7M	27	30	28	6.5	1	30		
ST7M	41	45	43	6.5	2	45		
ST7M	55	60	58	6.5	3	60		
ST9M	38	40	38	9	1	40		
ST9M	58	60	58	9	2	60		
ST9M	78	80	78	9	3	80		
ST12M	44	50	47.4	11.2	1	50		
ST12M	69	75	72.4	11.2	2	75		
ST12M	94	100	97.4	11.2	3	100		

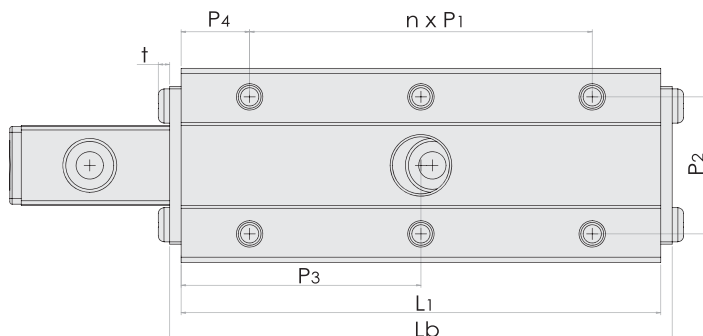

Block Dimensions (mm)						Model Code
P ₁	P ₂	W	h ₂	Mxg ₂	t	
15	12	17	6.5	M2x2.5	1	ST7M
20	15	20	7.8	M3x3.0	1.3	ST9M
25	20	27	10	M3x3.5	1.3	ST12M

Block Dimensions (mm)				Load Capacities		Static Moment		
L ₁	P ₄	n	P ₃	C _{100B} (dyn)	C ₀ (stat)	M _{ro}	M _{po}	M _{yo}
28	6.5	1	14	910	1580	5.9	3.4	3.4
43	6.5	2	21.5	1220	2500	9.1	8	8
58	6.5	3	29	1490	3330	12.4	14.6	14.6
38	9	1	19	1590	2773	13.1	6.8	6.8
58	9	2	29	2080	4170	19.7	16	16
78	9	3	39	2520	5547	26.2	29.2	29.2
47.4	11.2	1	23.7	2550	4340	27	16	16
72.4	11.2	2	36.2	3350	6510	40.1	35.6	35.6
97.4	11.2	3	48.7	4050	8670	54	62.8	62.8

cpc AR/HR Z Series Lubrication Storage Pad Testing Report

A linear guide is a category of rolling guidance, by using unlimited re-circulating stainless steel balls operate between the raceways of the rail and the block, result in the moving table achieving high precision and low friction linear movement. If the linear guide do not have sufficient lubrication, rolling friction will increase, cause wear and shortened linear guide life span in long term operation.

cpc has added and embedded PU lubricant storage pads to lengthen linear guide operational life; the pads directly contact and lubricate the rolling balls. This design supplies sufficient lubrication even during short-stroke operations.

cpc's design, due to the embedded pad's absorption and retention capabilities, results in a product that features a long operational life and long-term lubrication.

The following is the **cpc** in-house life test results:

AR15 Lubrication Storage Pad Testing Data

Testing products : AR15-Blocks with Lubrication Storages Pad 8pcs,
AR15-Rail-N-class-L1500mm 4pcs

Testing condition	
Rating load capacities(each Block)	1.8KN(C=9KN · C0=17.5KN)
Stroke	0.96m
Max running speed	1m/s
Lubricant	DAPHNE SUPER MULTI 68 (Viscosity64.32 CST 40OC)
Lubrication period	No lubrication added during testing period

■ Testing equipment



■ Testing result

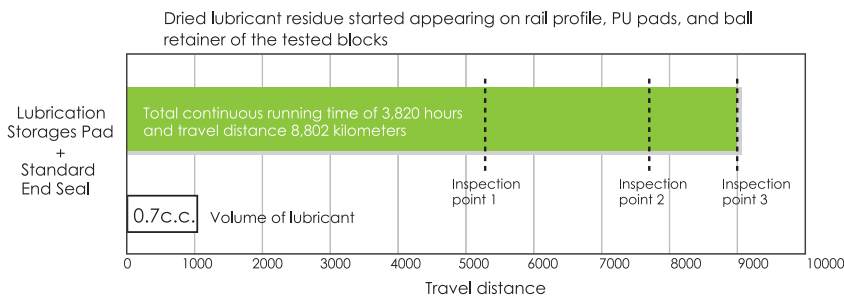

■ Testing result of inspection point

Inspection point 1 and 2

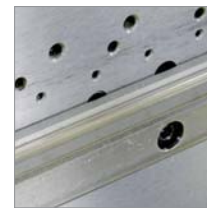

No wear on rail profile

Inspection point 3

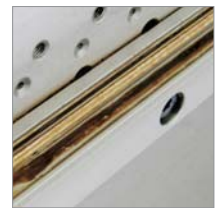

some rail profiles have dried lubricant residue present

Inspection point 1 and 2 : Lubrication result



- Upward Lubrication Storages Pad in good condition
- lubricant supply in good condition
- Running profile of rail no wear out



- Downward Lubrication Storages Pad in good condition
- lubricant supply in good condition

Inspection point 3 : Lubrication result



- Dried lubricant residue started appearing broken on upward Lubrication Storages pad of the tested blocks



- Dried lubricant residue started appearing broken on downward Lubrication Storages pad of the tested blocks

Plastic parts and end seal in good condition



Plastic parts in good condition



End seal in good condition

■ Test Summary

Total continuous running time of 3820 hours and travel distance 8802 kilometers. Out of eight test blocks, dried lubricant residue appeared on 2 blocks and 1 rail. Dried lubricant residue is indicative of a need for re-lubrication. The test results indicated that the lubrication pad design effectively extends re-lubrication requirement and thus lengthens linear operational life.



* Please note that the specifications are subject to change without notice due to product improvements.

cpc CHIEFTEK PRECISION Co., LTD.

HEADQUARTER

CHIEFTEK PRECISION Co., LTD.

No.3, Dali 1st Rd., Sinshih Township,
Tainan Science Park, 741-45 Tainan, Taiwan, R.O.C
TEL:+886-6-505 5858 [Http://www.chieftek.com](http://www.chieftek.com)
E-mail:service@mail.chieftek.com

CHIEFTEK PRECISION USA

3857-2E Schaefer Ave. Chino, CA 91710
Tel: +1-909-628-9300
Fax: +1-909-628-7171

CHIEFTEK MACHINERY KUNSHAN Co., LTD.

No.1188, Hongqiao Rd, Kunshan,
Jiangsu, P.R. China
TEL:+86-512-5525 2831
FAX:+86-512-5525 2851

PRINTED DATE : 20100412