

Model 702 Shaft



Features

- Standard Size 20 Package (2" x 2")
- Flange, and Servo Mounting
- Up to 30,000 CPR
- 80 lb Max. Axial and Radial Shaft Loading
- IP66 Sealing Available

The Model 702 Size 20 Accu-Coder™ is a heavy duty, extremely rugged, reliable, yet compact industry standard 2" diameter encoder, designed for harsh factory and plant floor environments. The double shielded ball bearings are rated at 80 lb maximum axial and radial shaft loading to ensure a long operating life. Made to withstand the harsh effects of the real world, both the flange and servo models are rated IP66 (NEMA 4 & 13) with the optional heavy duty shaft seal. With a variety of mounting options in both the flange and servo models, the Model 702 is ideal for both new applications and replacements. If you need an encoder that won't let you down, the Model 702 is it.

Common Applications

Motion Control Feedback, Conveyors, Elevator Controls, Machine Control, Food Processing, Process Control, Robotics, Material Handling, Textile Machines

Model 702 Ordering Guide

Blue type indicates price adder options. Not all configuration combinations may be available. Contact Customer Service for details.

702	20	S	1000	R	HV	1	F	1	E	X	N	CE
MODEL 702 Size 20 (2.0")		OPERATING TEMPERATURE S 0° to 70° C H 0° to 100°C ³			OUTPUT TYPE 5 - 28V In/Out ⁵ OC Open Collector PU Pull-Up Resistor PP Push-Pull HV Line Driver ¹⁰			SEAL N No Seal 1 IP66 2 IP64	CONNECTOR LOCATION E End S Side		MATING CONNECTOR N No Y Yes	CERTIFICATION N None CE CE Marked ⁹
	SHAFT SIZE¹ 07 1/4", 0.250" 20 3/8", 0.375" 21 10 mm 30 3/8", 0.375" ² 24 1/4", 0.250" No Flat		CYCLES PER REVOLUTION 1-30,000 See CPR Options below for available resolutions. Price adder for CPR >1270		8 - 28V In/5V Out^{6,12} H5 Line Driver ¹⁰ P5 Push-Pull					CONNECTOR TYPE¹¹ W 6-pin MS Style Y 7-pin MS Style X 10-pin MS Style 9D 9-pin D-subminiature J 5-pin M12 (12 mm) K 8-pin M12 (12 mm) G Gland, 24" Cable ⁸ H 10-pin Bayonet		
			NUMBER OF CHANNELS⁴ A Channel A Channel A Leads B Q Quadrature A & B R Quadrature A & B with Index Channel B Leads A K Reverse Quadrature A & B D Reverse Quadrature A & B with Index		MAXIMUM FREQUENCY 1 100 kHz (Standard) 2 200 kHz 5 250 kHz, >3000 CPR 3 500 kHz, >6000 CPR ⁷ 4 1 MHz, >10,000 CPR ⁷		MOUNTING Flange Mounts F 1.181" Female Pilot L 0.687" Male Pilot G 1.250" Male Pilot K Size 25 w/30 Shaft Servo Mounts S #1 w/1.181" Female Pilot U #1 w/0.687" Male Pilot T #1 w/1.250" Male Pilot C #2 w/1.181" Female Pilot E #2 w/0.687" Male Pilot D #2 w/1.250" Male Pilot P #3 w/1.181" Female Pilot Q #3 w/0.687" Male Pilot R #3 w/1.250" Male Pilot J Size 25 w/30 Shaft					

Accessory Mounting Bracket can be ordered separately as part # 140122. For more details www.Encoder.com

NOTES:

- 1 Contact Customer Service for additional options.
- 2 Shaft with Size 25 Mounting Adapter, J or K mounting only.
- 3 0° to 85° C for certain resolutions, see CPR Options.
- 4 Contact Customer Service for non-standard index gating options.
- 5 24 VDC max for high temperature option.
- 6 Standard temperature, 60 to 3000 CPR only.
- 7 Standard cable lengths only. For details, please refer to **Technical Bulletin TB116: Noise & Signal Considerations**.
- 8 For non-standard cable lengths, add a forward slash (/) plus cable length expressed in feet. Example: G/6 = 6 feet of cable.
- 9 Please refer to **Technical Bulletin TB 100: When to Choose the CE Option** found on the web at www.encoder.com.
- 10 Not available with 5-pin M12 or 6-pin MS Type connector. Available with 7-pin MS Type connector only without Index Z.
- 11 For Mating Connectors, Cables, and Cordsets see Electrical Accessories on the web at www.encoder.com.
- 12 H5 and P5 outputs are not available with CE option, or any End Mount MS Connector

Model 702 CPR Options

0001*	0002*	0004*	0005*	0006*	0007*	0008*	0010*	0011*
0012*	0014*	0020	0021*	0024*	0025*	0028*	0030*	0032*
0033*	0034*	0035*	0038*	0040*	0042*	0045*	0050*	0060
0064*	0100	0120	0125	0128*	0144*	0150*	0160*	0192*
0200	0240*	0250	0254*	0256*	0300	0333*	0360	0400
0500	0512	0600	0625*	0635	0665*	0720	0768*	0800
0889	0900*	1000	1024	1200	1201* ^a	1203* ^a	1204* ^a	1250 ^a
1270 ^a	1440	1500	1800	2000	2048	2400 ^a	2500	2540 ^a
2880 ^a	3000 ^a	3600 ^a	4000 ^a	4096 ^a	5000 ^a	6000 ^a	7200 ^a	7500 ^a
9000 ^a	10,000 ^a	10,240 ^a	12,000 ^a	12,500 ^a	14,400 ^a	15,000 ^a	18,000 ^a	20,000 ^a
20,480 ^a	25,000 ^a	30,000 ^a						

* Contact Customer Service for High Temperature Option.

^a High Temperature Option (H) limited to 85° C maximum for these CPR options.

New CPR values are periodically added to those listed. Contact Customer Service to determine all currently available CPR values. Special disk resolutions are available upon request. A one-time NRE fee may apply.

Model 702 Shaft

Model 702 Specifications

Electrical

Input Voltage.....	4.75 to 28 VDC max for temperatures up to 70° C 4.75 to 24 VDC for temperatures between 70° C to 100° C
Input Current.....	100 mA max with no output load
Input Ripple.....	100 mV peak-to-peak at 0 to 100 kHz
Output Format.....	Incremental- Two square waves in quadrature with channel A leading B for clockwise shaft rotation, as viewed from the encoder mounting face. See <i>Waveform Diagrams</i> .
Output Types.....	Open Collector- 100 mA max per channel Pull-Up- 100 mA max per channel Push-Pull- 20 mA max per channel Line Driver- 20 mA max per channel (Meets RS 422 at 5 VDC supply)
Index.....	Occurs once per revolution. The index for units >3000 CPR is 90° gated to Outputs A and B. See <i>Waveform Diagrams</i> .
Max Frequency.....	Up to 1 MHz.
Noise Immunity.....	Tested to BS EN61000-4-2; IEC801-3; BS EN61000-4-4; DENV 50141; DENV 50204; BS EN55022 (with European compliance option); BS EN61000-6-2; BS EN50081-2
Symmetry.....	1 to 6000 CPR: 180° (±18°) electrical at 100 kHz output 6001 to 20,480 CPR: 180° (±36°) electrical
Quad Phasing.....	1 to 6000 CPR: 90° (±22.5°) electrical at 100 kHz output 6001 to 20,480 CPR: 90° (±36°) electrical
Min Edge Sep.....	1 to 6000 CPR: 67.5° electrical at 100 kHz output 6001 to 20,480 CPR: 54° electrical >20,480 CPR: 50° electrical
Rise Time.....	Less than 1 microsecond
Accuracy.....	Instrument and Quadrature Error: For 200 to 1999 CPR, 0.017° mechanical (1.0 arc minutes) from one cycle to any other cycle. For 2000 to 3000 CPR, 0.01° mechanical (0.6 arc minutes) from one cycle to any other cycle. Interpolation error (units > 3000 CPR only) within 0.005° mechanical. (Total Optical Encoder Error = Instrument + Quadrature + Interpolation)

Mechanical

Max Shaft Speed.....	8000 RPM. Higher shaft speeds may be achievable, contact Customer Service.
Shaft Size.....	0.250", 0.375", or 10 mm
Shaft Rotation.....	Bi-directional
Radial Shaft Load.....	80 lb max. Rated load of 20 to 40 lb for bearing life of 1.5×10^9 revolutions
Axial Shaft Load.....	80 lb max. Rated load of 20 to 40 lb for bearing life of 1.5×10^9 revolutions
Starting Torque.....	1.0 oz-in typical with IP64 seal or no seal 3.0 oz-in typical with IP66 shaft seal
Moment of Inertia.....	5.2×10^{-4} oz-in-sec ²
Max Acceleration.....	1×10^5 rad/sec ²
Connector Type.....	6-, 7-, and 10-pin MS Style, 5- or 8-pin M12 (12 mm), 9-pin D-subminiature, or gland with 24 inches of cable (foil and braid shield, 24 AWG conductors), 10-pin Bayonet
Housing.....	Black non-corrosive finish
Bearings.....	Precision ABEC ball bearings
Mounting.....	Various flange or servo mounts
Weight.....	11 oz typical

Environmental

Operating Temp.....	0° to 70° C for standard models 0° to 100° C for high temperature option (0° to 85° C for certain resolutions, see CPR Options.)
Storage Temp.....	-25° to +85° C
Humidity.....	98% RH non-condensing
Vibration.....	20 g @ 58 to 500 Hz
Shock.....	75 g @ 11 ms duration
Sealing.....	IP66 (NEMA 13 and 4/4X) with shaft seal on flange and servo mounts; or IP64 available.

Model 702 Servo Mounts

Servo #1 (S)

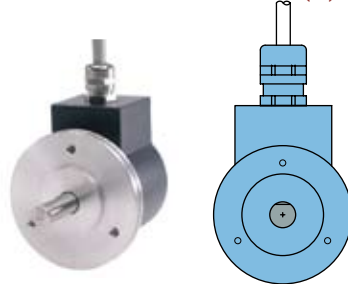

SERVO MOUNT #1
4-40 UNC-2B 0.25 DEEP
3X 120° Ø1.500 B.C.

Servo #2 (C)

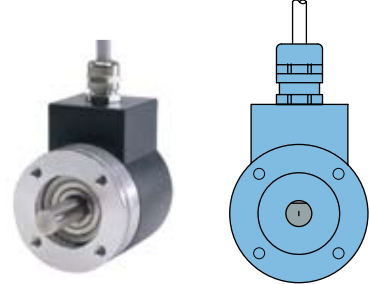

SERVO MOUNT #2
10-32 UNF-2B 0.25 DEEP
4X 90° Ø1.625 B.C.

Servo #3 (P)

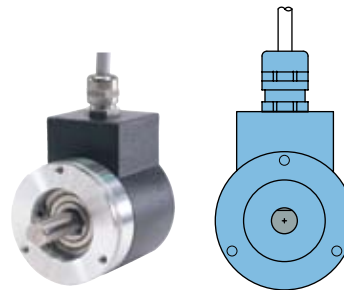

SERVO MOUNT #3
6-32 UNC-2B 0.25 DEEP
3X 120° Ø1.750 B.C.

Body For Servo Mounts #1, #2, #3

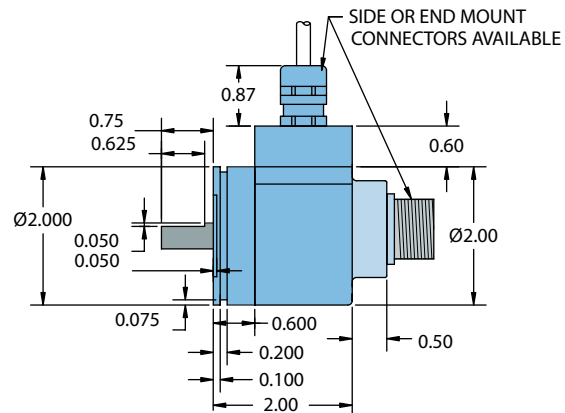

Optional Pilots For Flange And Servo Mounts

(G, T, D, R)

(L, U, E, Q)

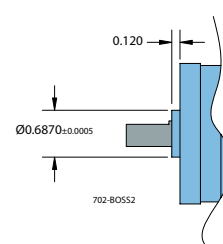
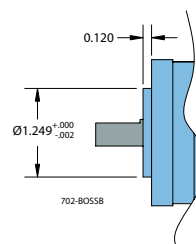

All dimensions are in inches with a tolerance of ±0.005" or ±0.01" unless otherwise specified

Model 702 Shaft

Model 702 Flange Mount (F)

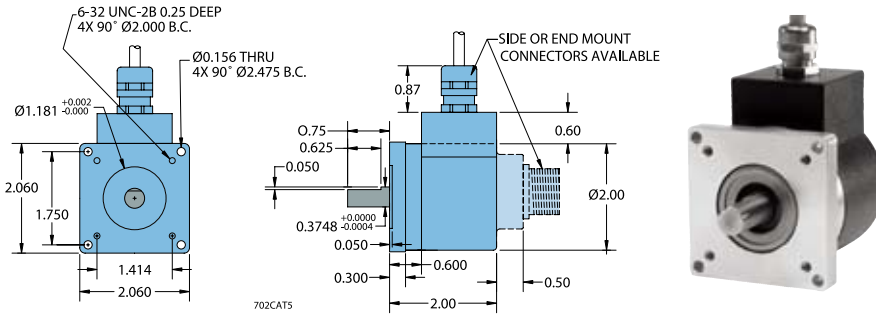

Waveform Diagrams

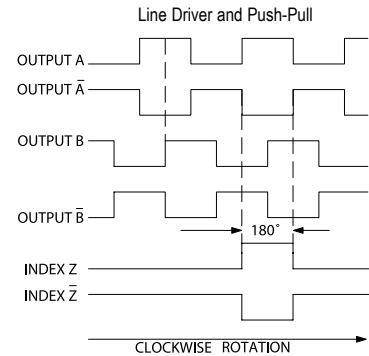

NOTE: ALL DEGREE REFERENCES ARE ELECTRICAL DEGREES
LDSIGC

Model 702 With 2.5" Flange Mount (K)

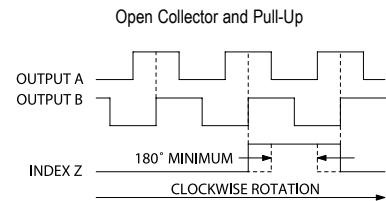
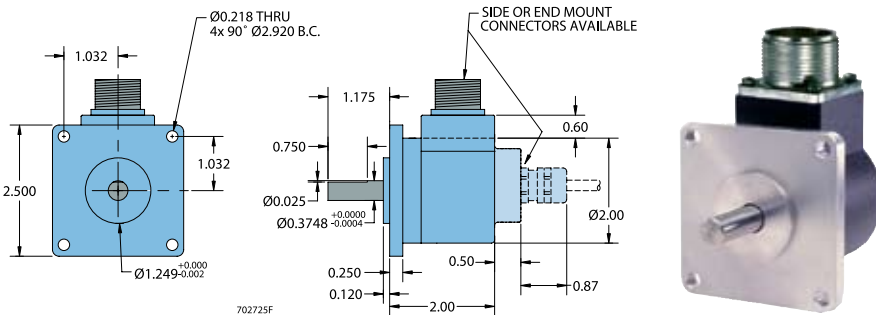

NOTE: ALL DEGREE REFERENCES ARE ELECTRICAL DEGREES
SESIGC

NOTE: INDEX IS POSITIVE GOING

Model 702 With 2.5" Servo Mount (J)

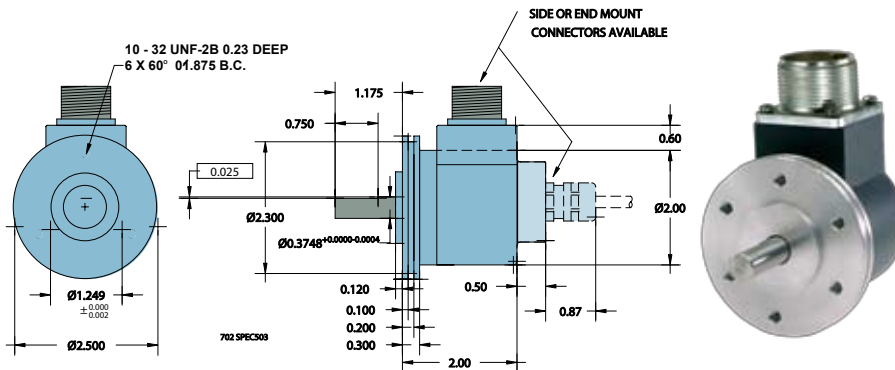

All dimensions are in inches with a tolerance of ±0.005" or ±0.01" unless otherwise specified

Wiring Table

Function	Gland Cable Wire Color	5-pin M12 ¹	8-pin M12 ²	10-pin MS	7-pin MS HV,H5	7-pin MS PU, PP, OC, P5	6-pin MS PU, PP, OC, P5	9-pin D-sub	10-pin Bayonet
Com	Black	3	7	F	F	F	A, F	9	F
+VDC	Red	1	2	D	D	D	B	1	D
A	White	4	1	A	A	A	D	2	A
A'	Brown	---	3	H	C	---	---	3	H
B	Blue	2	4	B	B	B	E	4	B
B'	Violet	---	5	I	E	---	---	5	J
Z	Orange	5	6	C	---	C	C	6	C
Z'	Yellow	---	8	J	---	---	---	7	K
Case	Green	---	---	G	G	G	---	8	G
Shield	Bare ¹	---	---	---	---	---	---	---	---

¹CE Option: Cable shield (bare wire) is connected to internal case
²CE Option: Read Technical Bulletin TB111

Connector Pin-Outs

