

# Model 725



## Features

- Standard Size 25 Package (2.5" x 2.5")
- Up to 30,000 CPR
- Standard and Industrial Housings
- Servo and Flange Mounting
- IP66 Sealing Available

Model 725 Size 25 Accu-Coder™ optical shaft encoder is specifically designed for the challenges of an industrial environment. But don't let its tough, industrial package fool you; it still has the performance to reach resolutions up to 30,000 cycles per revolution. The Model 725 is available with both flange and servo mounting options, along with two distinctive 2.5" diameter housing styles. The rugged Standard Housing (N) isolates the internal electronics from the shock and stress of the outer environment. The extra heavy-duty Industrial Housing (I) features a fully isolated internal encoder unit that prolongs bearing life by using an internal flexible mount to protect the encoder from severe axial and radial shaft loading.

## Common Applications

Motion Control Feedback, Conveyors, Elevator Controls, Machine Control, Food Processing, Process Control, Robotics, Material Handling, Textile Machines

## Model 725 Ordering Guide

Blue type indicates price adder options. Not all configuration combinations may be available. Contact Customer Service for details.

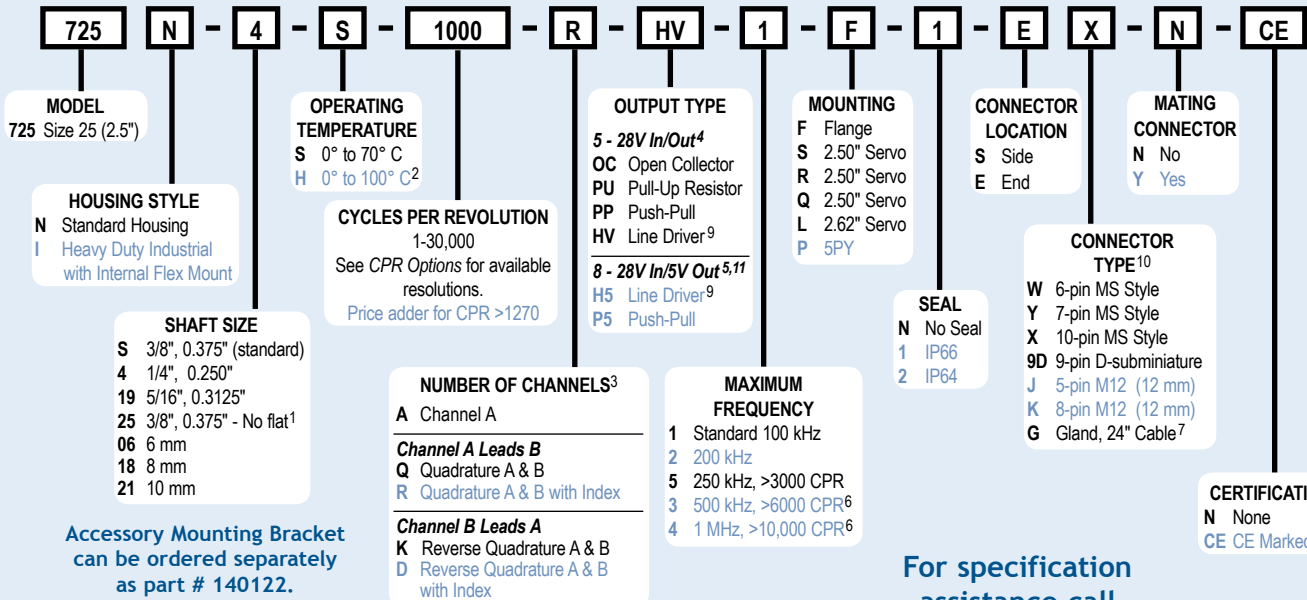

Accessory Mounting Bracket can be ordered separately as part # 140122. For more details [www.Encoder.com](http://www.Encoder.com)

For specification assistance call Customer Service at 1-800-366-5412

## Model 725 CPR Options

0001*	0002*	0004*	0005*	0006*	0007*	0008*	0010*	0011*
0012*	0014*	0020	0021*	0024*	0025*	0028*	0030*	0032*
0033*	0034*	0035*	0038*	0040*	0042*	0045*	0050*	0060
0064*	0100	0120	0125	0128*	0144*	0150*	0160*	0192*
0200	0240*	0250	0254*	0256*	0300	0333*	0360	0400
0500	0512	0600	0625*	0635	0665*	0720	0768*	0800
0889	0900*	1000	1024	1200	1201* <sup>a</sup>	1203* <sup>a</sup>	1204* <sup>a</sup>	1250 <sup>a</sup>
1270 <sup>a</sup>	1440	1500	1800	2000	2048	2400 <sup>a</sup>	2500	2540 <sup>a</sup>
2880 <sup>a</sup>	3000 <sup>a</sup>	3600 <sup>a</sup>	4000 <sup>a</sup>	4096 <sup>a</sup>	5000 <sup>a</sup>	6000 <sup>a</sup>	7200 <sup>a</sup>	7500 <sup>a</sup>
9000 <sup>a</sup>	10,000 <sup>a</sup>	10,240 <sup>a</sup>	12,000 <sup>a</sup>	12,500 <sup>a</sup>	14,400 <sup>a</sup>	15,000 <sup>a</sup>	18,000 <sup>a</sup>	20,000 <sup>a</sup>
20,480 <sup>a</sup>	25,000 <sup>a</sup>	30,000 <sup>a</sup>						

\* Contact Customer Service for High Temperature Option.

<sup>a</sup> High Temperature Option (H) limited to 85° C maximum for these CPR options.

New CPR values are periodically added to those listed. Contact Customer Service to determine all currently available CPR values. Special disk resolutions are available upon request. A one-time NRE fee may apply.

## NOTES:

- 1 Available with I housing style only.
- 2 0° to 85° C for certain resolutions, see CPR Options.
- 3 Contact Customer Service for index gating options.
- 4 24 VDC max for high temperature option.
- 5 Standard temperature, 60 to 3000 CPR only.
- 6 Standard cable lengths only. For details, please refer to **Technical Bulletin TB116: Noise and Signal Distortion Considerations** at [www.encoder.com](http://www.encoder.com).
- 7 For Non-Standard Cable Lengths add a forward slash (/) plus cable length expressed in feet. Example: SG/6 = 6 feet of cable.
- 8 Please refer to **Technical Bulletin TB100: When to Choose the CE Option**.
- 9 Not available with 5-pin M12 or 6-pin MS connector. Available with 7-pin MS connector only without Index Z.
- 10 For Mating Connectors, Cables, and Cordsets see [www.encoder.com](http://www.encoder.com).
- 11 H5 and P5 outputs not available with CE option, or any End Mount MS Connector.

# Model 725

## Model 725 Specifications

### Electrical

Input Voltage.....	4.75 to 28 VDC max for temperatures up to 70° C 4.75 to 24 VDC for temperatures between 70° C to 100° C
Input Current.....	100 mA max with no output load
Input Ripple.....	100 mV peak-to-peak at 0 to 100 kHz
Output Format.....	Incremental- Two square waves in quadrature with channel A leading B for clockwise shaft rotation, as viewed from the encoder mounting face. See <i>Waveform Diagrams</i> below.
Output Types.....	Open Collector- 100 mA max per channel Pull-Up- 100 mA max per channel Push-Pull- 20 mA max per channel Line Driver- 20 mA max per channel (Meets RS 422 at 5 VDC supply)
Index.....	Occurs once per revolution. The index for units >3000 CPR is 90° gated to Outputs A and B. See <i>Waveform Diagrams</i> below.
Max Frequency.....	Up to 1 MHz
Noise Immunity.....	Tested to BS EN61000-4-2; IEC801-3; BS EN61000-4-4; DDEVN 50141; DDEVN 50204; BS EN55022 (with European compliance option); BS EN61000-6-2; BS EN50081-2
Symmetry.....	1 to 6000 CPR: 180° (±18°) electrical at 100 kHz output 6001 to 20,480 CPR: 180° (±36°) electrical
Quad Phasing.....	1 to 6000 CPR: 90° (±22.5°) electrical at 100 kHz output 6001 to 20,480 CPR: 90° (±36°) electrical
Min Edge Sep.....	1 to 6000 CPR: 67.5° electrical at 100 kHz output 6001 to 20,480 CPR: 54° electrical >20,480 CPR: 50° electrical
Rise Time.....	Less than 1 microsecond
Accuracy.....	Instrument and Quadrature Error: For 200 to 1999 CPR, 0.017° mechanical (1.0 arc minutes) from one cycle to any other cycle. For 2000 to 3000 CPR, 0.01° mechanical (0.6 arc minutes) from one cycle to any other cycle. Interpolation error (units > 3000 CPR only) within 0.005° mechanical. (Total Optical Encoder Error = Instrument + Quadrature + Interpolation)

### Mechanical

Max Shaft Speed.....	6000 RPM. Higher shaft speeds may be achievable, contact Customer Service.
Shaft Size.....	0.375" (standard), 0.250", 0.3125", 6 mm, 8 mm, 10 mm
Shaft Material.....	303 stainless steel
Shaft Rotation.....	Bi-directional
Radial Shaft Load.....	35 lb max (standard housing) 40 lb max (industrial housing)
Axial Shaft Load.....	40 lb max (standard housing) 45 lb max (industrial housing)
Starting Torque.....	1.0 oz-in typical with IP64 seal or no seal 3.0 oz-in typical with IP66 shaft seal
Moment of Inertia.....	$5.2 \times 10^{-4}$ oz-in-sec <sup>2</sup>
Max Acceleration.....	$1 \times 10^5$ rad/sec <sup>2</sup>
Electrical Conn.....	6-, 7-, or 10-pin MS Style, 5- or 8-pin M12 (12 mm), 9-pin D-subminiature, or gland with 24 inches of cable (foil and braid shield, 24 AWG conductors)
Housing.....	Black non-corrosive finish
Bearings.....	Precision ABEC ball bearings
Mounting.....	Flange, servo, or 5PY
Weight.....	20 oz typical

### Environmental

Operating Temp.....	0° to 70° C for standard models 0° to 100° C for high temperature option (0° to 85° C for certain resolutions, see CPR Options.)
Storage Temp.....	-25° to +85° C
Humidity.....	95% RH non-condensing
Vibration.....	725N: 10 g @ 58 to 500 Hz 725I: 20 g @ 58 to 500 Hz
Shock.....	725N: 50 g @ 11 ms duration 725I: 75 g @ 11 ms duration
Sealing.....	IP50 standard, IP64 and IP66 (NEMA 13 and 4/4X) optional

## Model 725 2.5" Servo Mount (S)

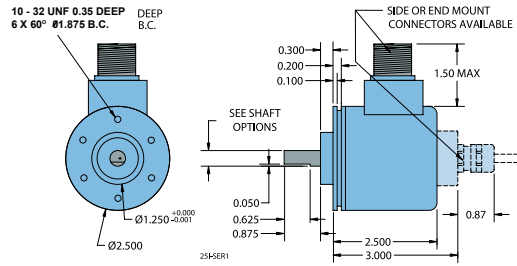

## Model 725 2.5" Servo Mount (R)

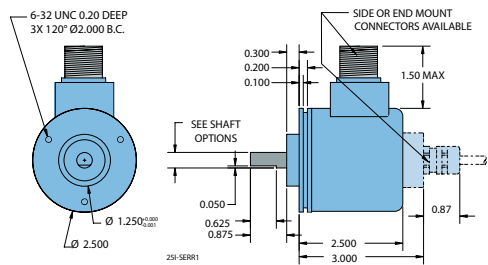

## Model 725 2.5" Servo Mount (Q)

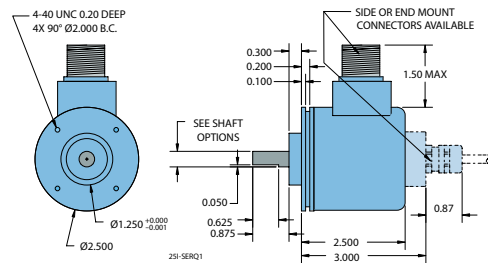

## Model 725 2.62" Servo Mount (L)

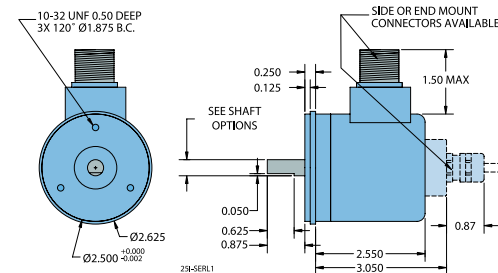

All dimensions are in inches with a tolerance of ±0.005" or ±0.01" unless otherwise specified

# Model 725

## Model 725 Flange Mount (F)

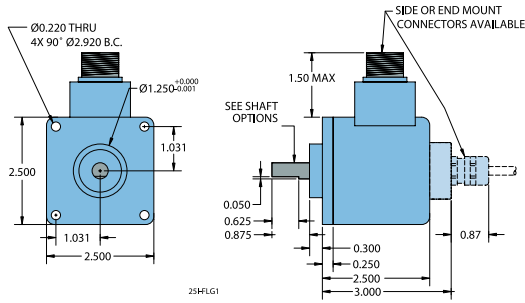

## Waveform Diagrams

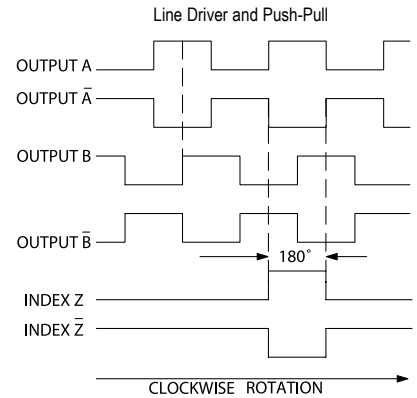

LDSKC

## Model 725 Optional 5PY Mounting (P)

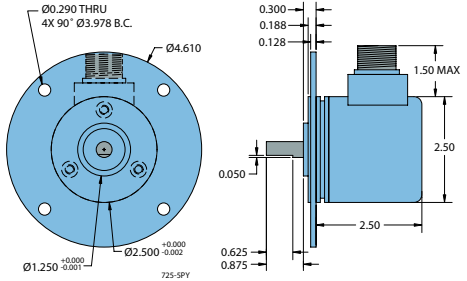

The optional 5PY adapter is made of all aluminum construction and allows Model 725 encoder to replace DC tachometer technology. The 5PY adapter is mechanically interchangeable with any 5PY tach generator.



All dimensions are in inches with a tolerance of ±0.005" or ±0.01" unless otherwise specified

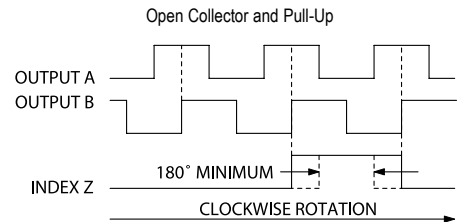

SESGC

NOTE: INDEX IS POSITIVE GOING

## Connector Pin-Outs

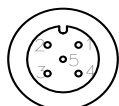

5-pin M12

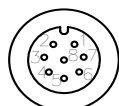

8-pin M12

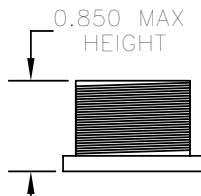
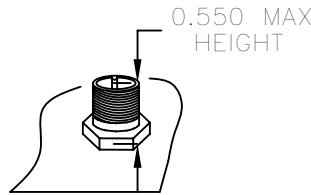

10-pin MS

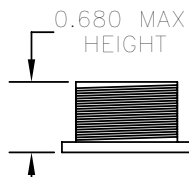

7-pin MS

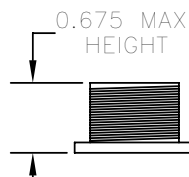

6-pin MS

## Wiring Table

Function	Gland Cable Wire Color	5-pin M12 <sup>2</sup>	8-pin M12 <sup>2</sup>	10-pin MS	7-pin MS HV,H5	7-pin MS PU, PP OC, P5	6-pin MS PU, PP OC, P5	9-pin D-sub
Com	Black	3	7	F	F	F	A, F	9
+VDC	Red	1	2	D	D	D	B	1
A	White	4	1	A	A	A	D	2
A'	Brown	---	3	H	C	---	---	3
B	Blue	2	4	B	B	B	E	4
B'	Violet	---	5	I	E	---	---	5
Z	Orange	5	6	C	---	C	C	6
Z'	Yellow	---	8	J	---	---	---	7
Case	Green	---	---	G	G	G	---	8
Shield	Bare <sup>1</sup>	---	---	---	---	---	---	---

<sup>1</sup>CE Option: Cable shield (bare wire) is connected to internal case

<sup>2</sup>CE Option: Read Technical Bulletin TB111