



PRECISION LINEAR MOUNT

GAM can. Just ask!

If you don't see exactly what you need, let us know. We can modify the EPL/RPL Series gearboxes to meet your needs. Page 3 provides a list of commonly requested modifications to give you a feel for our capabilities.

The Linear Mount Series takes the hassle out of mounting your motor or gearbox to a linear ball screw or belt module. The hollow output on the gearbox eliminates the need for any additional couplings or mounting adapters. GAM provides all the adapters and hardware required for the gearbox to mount to the slide and your motor. See LSK Section for motor mounts used with linear modules.

- Low backlash
- Precision gears
- Lightweight
- Lubricated for life
- Mounts to any off the shelf linear belt or ball screw modules
- All adapters and hardware included

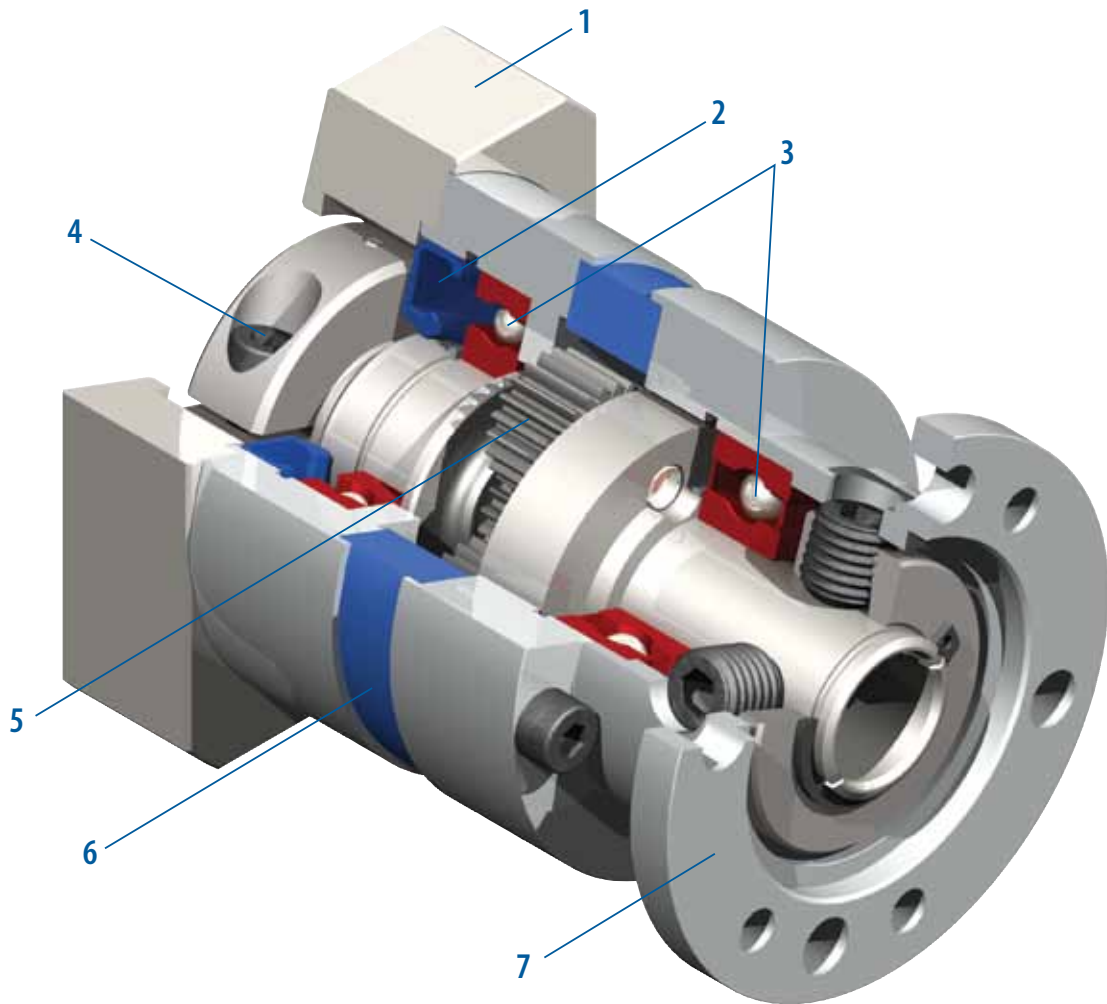

Just tell us what motor and what module you want to mount and GAM will take care of all the engineering.

- | | | |
|--|---|---|
| 1. Adapter Plate
(Customized adapter plates for quick and easy motor mounting) | 3. Ball Bearings
(Single ball bearing in the EPL-H-064; dual ball bearings in all other sizes and styles) | 6. Ring Gear
(Ring gear incorporated into housing) |
| 2. Seals
(Protective seals to isolate the gearbox) | 4. Input Clamping Element | 7. Output Face
(Ready to mount to belt or ball screw modules) |
| | 5. Planet Gears
(Precision honed gears) | |

PRECISION LINEAR MOUNT

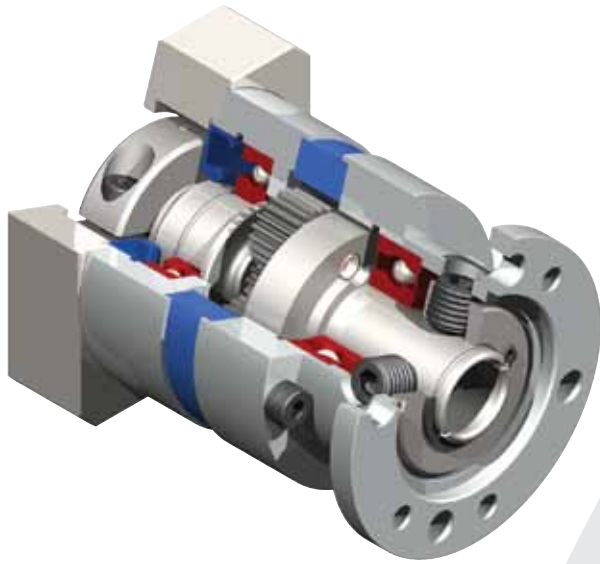

EPL-H Gearboxes

- Our most popular in-line planetary with a unique hollow output and zero-backlash clamping ring
- Quick, simple, and low-cost solution used to mount onto any off-the-shelf linear belt or ball screw modules
- Precision gears
- Ratios up to 1000:1
- Frame sizes from 64 mm to 118 mm
- Same backlash and efficiencies as EPL Series



EPL-H with Linear slide

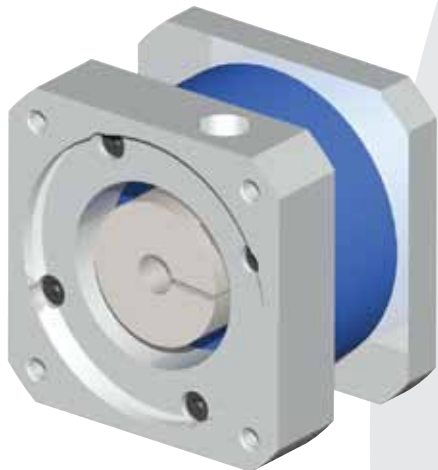

Linear Slide Kit (LSK)

- Customized assembly to mount any motor or gearbox to any linear slide
- Coupling included
- Quick delivery

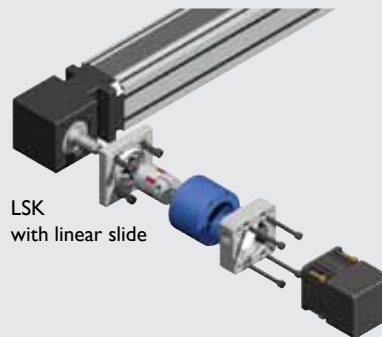

LSK with linear slide





▶ EPL SERIES: EPL-H



EPL Series		64	84	118	
Stock Ratios		3, 5, 7, 10, 25, 50, 100 (Standard Input)			
All Ratios Available		1-stage: 3, 4, 5, 7, 10			
		2-stage: 12, 16, 20, 25, 35, 40, 50, 70, 100			
		3-stage: 120, 160, 200, 250, 350, 490, 700, 1000			
Nominal Output Torque (T_{2n})	Nm (lb-in)	3:1, 10:1, 100:1, 1000:1	14 (124)	40 (354)	100 (885)
		4:1, 5:1, 7:1	26 (230)	50 (443)	120 (1062)
		all other ratios	36 (319)	64 (566)	165 (1460)
Max Accel Output Torque (T_{2B})	Nm (lb-in)	3:1, 10:1, 100:1, 1000:1	25 (221)	60 (531)	150 (1328)
		4:1, 5:1, 7:1	40 (354)	75 (664)	180 (1593)
		all other ratios	44 (389)	75 (664)	180 (1593)
Nominal Input Speed (n_{in})	RPM	-	3500	3000	3000
Max Input Speed (n_{imax})	RPM	-	6000	6000	6000
Standard Output Backlash (j)	arcmin	3:1 - 10:1	< 10	< 10	< 8
		12:1 - 100:1	< 15	< 14	< 12
		120:1 - 1000:1	< 20	< 18	< 16
Weight (m)	kg (lb)	1-stage	1.0 (2.2)	2.3 (5.1)	5.8 (12.8)
		2-stage	1.3 (2.9)	3.1 (6.8)	7.9 (17.4)
		3-stage	1.6 (3.5)	3.9 (8.6)	10.0 (22.1)
Noise Level (L_{pk})	dB (A)	-	< 66	< 68	< 70
Mass Moment of Inertia (J_1)	kg cm ² (lb-in ²)	3:1	0.176 (0.06)	0.542 (0.185)	2.54 (0.867)
		4:1	0.159 (0.054)	0.424 (0.145)	1.76 (0.601)
		5:1	0.15 (0.051)	0.379 (0.129)	1.48 (0.505)
		7:1, 10:1	0.138 (0.047)	0.332 (0.113)	1.14 (0.389)
		12:1 - 35:1	0.156 (0.053)	0.407 (0.139)	1.51 (0.515)
		40:1 - 1000:1	0.136 (0.046)	0.327 (0.112)	1.07 (0.365)
Efficiency at Load		1-stage: 92% 2-stage: 90% 3-stage: 88%			
Service Life		> 20,000 hours			
Lubrication		Mineral Grease EPO			
Protection Rating		IP 64			
Operating Temperature Range		-20°C to 90°C			

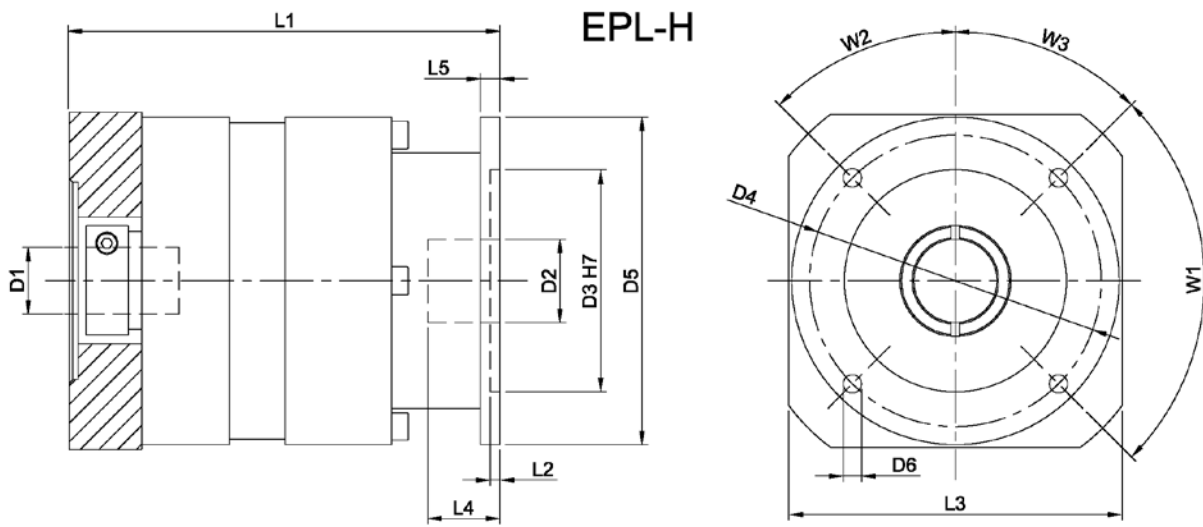

EPL Series		64		84		118	
		mm	(in)	mm	(in)	mm	(in)
D1 max standard*	motor shaft diameter	14	(0.551)	19	(0.748)	24	(0.945)
D1 max available*	motor shaft diameter	16	(0.63)	24	(0.945)	32	(1.26)
D2 max	output shaft diameter	16	(0.63)	20	(0.787)	30	(1.181)
D3 H7	pilot diameter	44	(1.732)	60	(2.362)	80	(3.15)
D4	bolt circle	55.5	(2.185)	73	(2.874)	105	(4.134)
D5	flange diameter	70	(2.756)	84	(3.307)	118	(4.646)
D6	mounting holes	5.5	(0.217)	5.5	(0.217)	6.6	(0.26)
L1 1-STAGE**	gearbox total length	98.5	(3.878)	122	(4.803)	155.5	(6.122)
L1 2-STAGE**		120.5	(4.744)	155	(6.102)	196	(7.717)
L1 3-STAGE**		142.5	(5.61)	188	(7.402)	236.5	(9.311)
L2	pilot depth	3.5	(0.138)	3.5	(0.138)	3.5	(0.138)
L3	flange size	70	(2.756)	90	(3.543)	120	(4.724)
L4	allowable shaft depth	28	(1.102)	30	(1.181)	27	(1.063)
L5	flange thickness	6	(0.236)	6	(0.236)	10	(0.394)
W1	bolt hole spacing	125°		4x 90°		4x 90°	
W2	hole angle 1	27.5°		67.5°		67.5°	
W3	hole angle 2	27.5°		22.5°		22.5°	

* for larger motor shaft diameters, please contact GAM ** depending on the motor, value can vary

TYPE CODES FOR EPL/RPL SERIES (EPL-H)

Example: EPL - H - 084 - 005 H - [115 - A01] - S111

Gearbox Series

EPL w/ Linear Mount
Output

Gearbox Style

H = Hollow Output Shaft

Gearbox Size

064, 084, 118

Ratio

3, 4, 5, 7, 10, 12, 16, 20, 25, 35, 40, 50, 70, 100,
120, 160, 200, 250, 350, 490, 700, 000 = 1000

Special Options

Assigned by GAM

Motor Mount Kit

Assigned by GAM

Options Available for This Product

H = No Keyways

Tolerances (mm)	
Size	H7
Over 6	+0.015
Thru 10	0
Over 10	+0.018
Thru 18	0
Over 18	+0.021
Thru 30	0
Over 30	+0.025
Thru 50	0
Over 50	+0.030
Thru 80	0



► PRECISION LINEAR MOUNT: LINEAR SLIDE KIT (LSK)

GAM can. Just ask!

If you don't see exactly what you need, let us know. We can modify the LSK to meet your needs.

Our no-hassle solution for mounting linear slides to motors and gearboxes is our LSK (Linear Slide Kit.) It can be customized to any motor or gearbox and linear slide. A coupling is included – bellows or elastomer. The LSK is readily available and comes complete with mounting hardware. You just need to tighten the bolts.

- A customized mounting solution without the long lead times
- Three sizes
- Quick delivery
- Reasonably priced
- GAM provides all engineering and design for your application

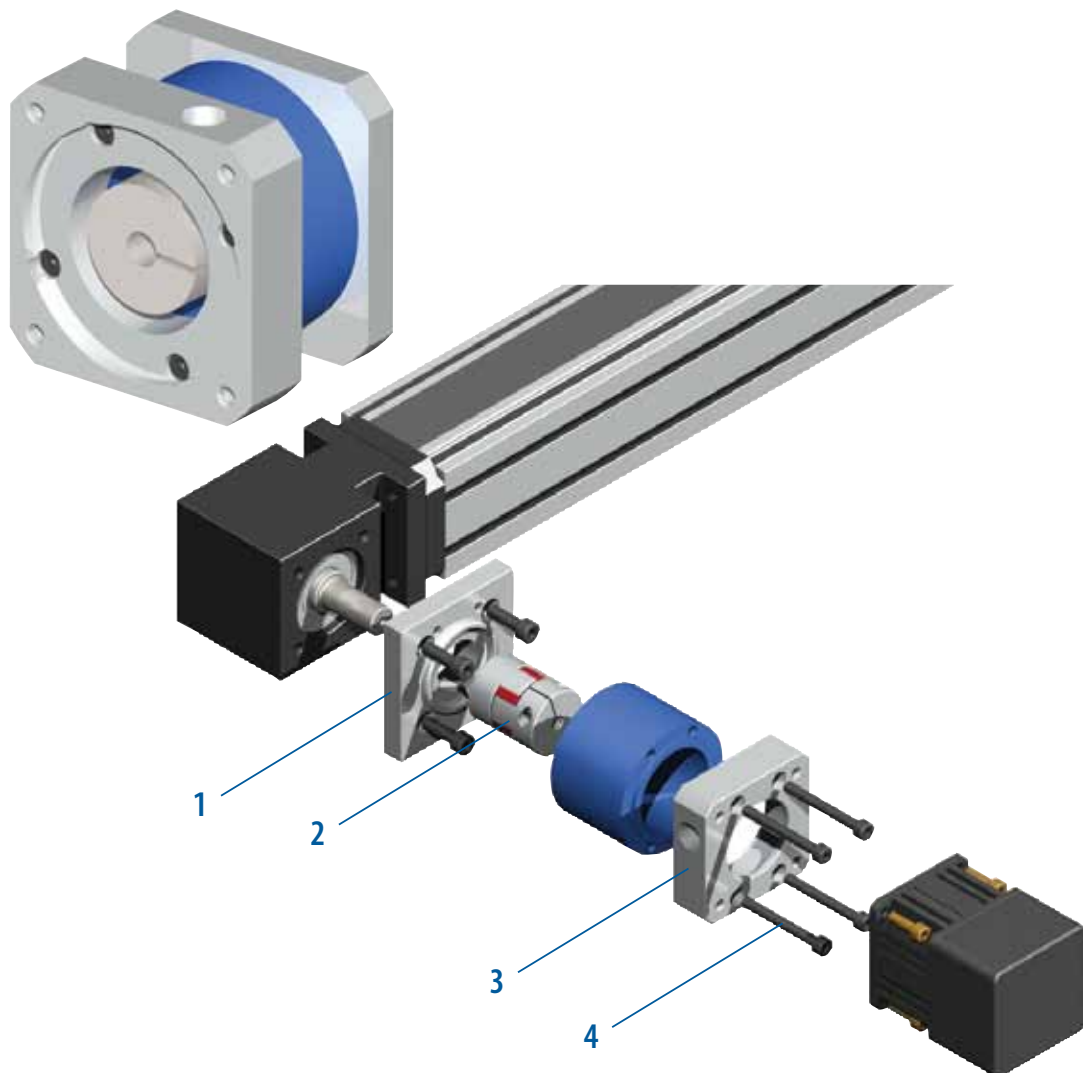

Just tell us what motor and what module you want to mount and GAM will take care of all the engineering.

- | | |
|---|---|
| 1. Slide Adapter Flange
(Custom adapter for any linear slide module) | 3. Motor Adapter Flange
(Custom adapter for any servo motor) |
| 2. Coupling
(Custom machined coupling with or without keyways) | 4. Hardware
(All mounting hardware provided in kit) |

PRECISION LINEAR MOUNT: LINEAR SLIDE KIT (LSK)

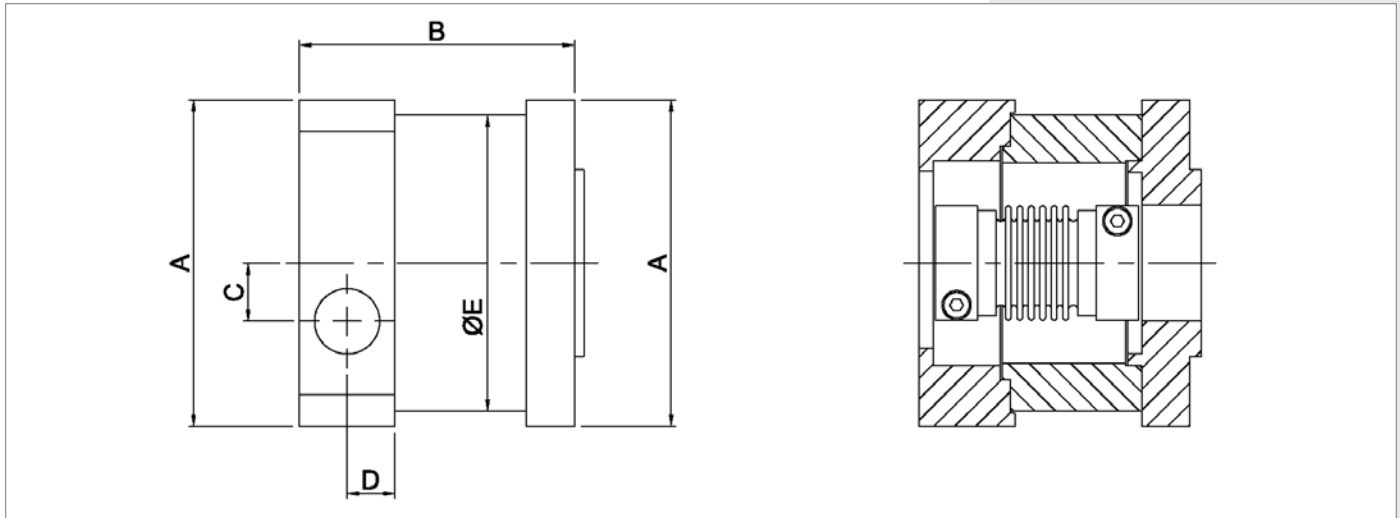

	Coupling Type	Rated Torque Nm (lb-in)	Min Shaft Diameter mm (in)	Max Shaft Diameter mm (in)	Coupling Stiffness 10 ³ Nm/rad (lb-ft/deg)	Coupling Inertia 10 ³ kg-m ² (lb-in ²)	Amin mm (in)	Bmin mm (in)	E mm (in)
LSK21	Bellows	4 (35)	3 (0.12)	14* (0.55)	1.8 (23)	0.003 (0.01)	70 (2.75)	62 (2.44)	63.5 (2.50)
LSK22	Bellows	8 (71)	6 (0.24)	19.05* (0.75)	6.5 (84)	0.02 (0.07)	70 (2.75)	70 (2.75)	63.5 (2.50)
LSK23	Elastomer	8 (71)	6 (0.24)	16* (0.63)	0.16 (2.1)	0.01 (0.03)	70 (2.75)	62 (2.44)	63.5 (2.50)
LSK31	Elastomer	15 (133)	9.53 (0.375)	19.05* (0.75)	0.82 (10.6)	0.03 (0.10)	88.9 (3.50)	74 (2.91)	88.9 (3.50)
LSK32	Bellows	25 (221)	9.53 (0.375)	28* (1.10)	12 (154)	0.09 (0.31)	88.9 (3.50)	81 (3.19)	88.9 (3.50)
LSK33	Elastomer	30 (266)	12.7 (0.50)	26* (1.02)	1.4 (18)	0.09 (0.31)	88.9 (3.50)	74 (2.91)	88.9 (3.50)
LSK41	Bellows	50 (443)	15 (0.59)	35* (1.38)	22 (282)	0.22 (0.75)	120 (4.72)	86 (3.39)	114.3 (4.50)
LSK42	Elastomer	60 (531)	15 (0.59)	29* (1.14)	2.1 (27)	0.18 (0.62)	120 (4.72)	86 (3.39)	114.3 (4.50)
LSK43	Bellows	125 (1106)	16 (0.625)	44* (1.73)	44 (565)	0.75 (2.56)	120 (4.72)	95 (3.74)	114.3 (4.50)
LSK44	Elastomer	150 (1328)	22 (0.87)	38.1* (1.50)	3.6 (46)	0.38 (1.30)	120 (4.72)	105 (4.13)	114.3 (4.50)

* An extra adapter may be required for a C-face mounting (motor or gearbox side only)

TYPE CODES FOR LSK SERIES

Example: LSK32K-0001

LSK Size
2, 3, 4

Coupling Size / Style
1, 2, 3, 4

Series Number
Assigned by GAM

Keyways*
(N= No Keyways,
K= Keyways)
*Full keyway not available
for max shaft diameter
Contact GAM for other
options