

COMPONENTS

MODULES

ROBOTICS

SYSTEMS

Zahnstangen und Ritzel
Gammes de crémaillés et pignons
Rack and pinion programm

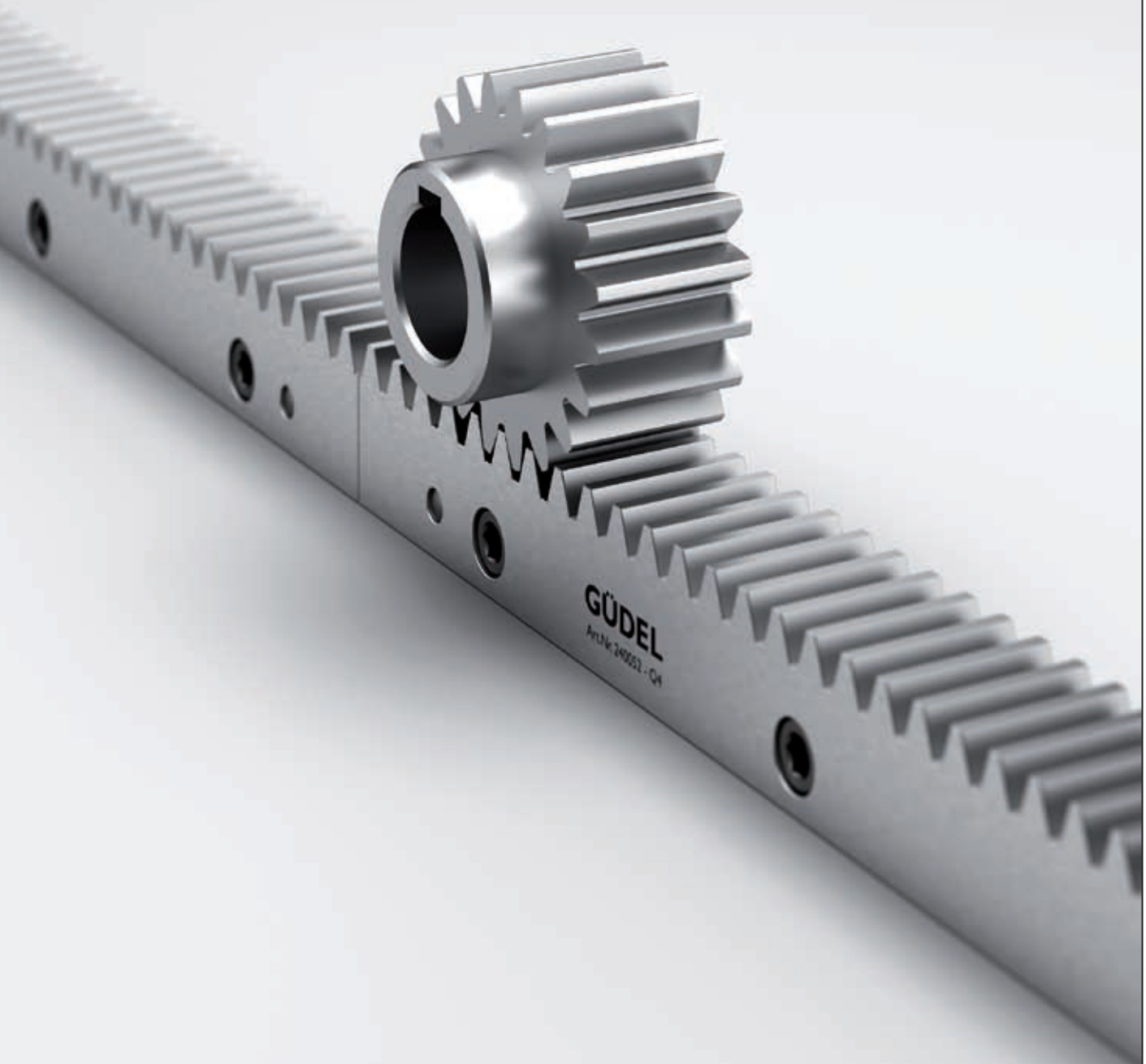

Voller Konzentration haben wir diesen Katalog auf Herz und Nieren geprüft. Trotzdem können sich fehlerhafte oder unvollständige Angaben eingeschlichen haben, für die wir keine Haftung übernehmen möchten. Nachdrucke dieses Werkes sind verständlich und wünschenswert, aber ohne eine Genehmigung von unserer Seite nicht erlaubt. Technische Verbesserungen der Produkte behalten wir uns vor.

C'est avec le plus grand soin que nous avons contrôlé ce catalogue. Nous déclinons cependant toute responsabilité quant à d'éventuelles erreurs ou omissions. Nous comprenons et apprécions le fait que vous désiriez reproduire ce document, souhaitons cependant vous informer que cela n'est possible qu'après notre accord explicite. Nous nous réservons le droit de procéder à des améliorations techniques.

We have checked this catalogue with great care and diligence. However, we do not accept liability for incorrect or incomplete information that has gone undetected. We understand and appreciate that you might want to reproduce this document. However, this is not permitted without our authorization. We reserve the right to make technical improvements to the products.

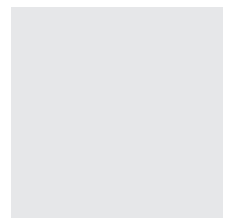

Mit unserem weltweit aufgestellten Team und unseren Kunden arbeiten wir stets Hand in Hand. So können wir Ziele schneller erreichen, umfangreiche Konzepte und individuelle Kundenwünsche erfüllen.

Unsere hauseigen gefertigten Komponenten und Robotiks versprechen 1a-Qualität und dienen als Grundlage für technologisch anspruchsvolle Lösungen für die Automation und integrierte Systeme. Sie werden schwergpunktmäßig im Transportwesen, in verarbeitenden Industrien, in der Energieerzeugung und der Logistik eingesetzt.

Als serviceorientierter Dienstleister verknüpfen wir mit jedem Auftrag eine langfristige Partnerschaft und ein umfassendes Serviceangebot. Das beherzigen wir seit über 50 Jahren.

Nous mettons un point d'honneur à établir une étroite collaboration entre notre équipe internationale et nos clients. Nous sommes ainsi en mesure d'atteindre plus rapidement les objectifs fixés, de développer les concepts les plus complexes et d'être en permanence à l'écoute de vos besoins.

Les composants et la robotique fabriqués dans nos usines sont d'une qualité à toute épreuve et servent de base au développement de solutions technologiques de pointe dans les domaines de l'automatisation et des systèmes intégrés. Ils sont principalement utilisés dans les secteurs du transport, de l'industrie manufacturière, de la production énergétique et de la logistique.

Depuis plus de cinquante ans, nous mettons la qualité des services que nous fournissons au centre de nos préoccupations. Le lancement d'un projet représente pour nous le point de départ d'un long partenariat avec nos clients pour lesquels, nous mettons volontiers à leur disposition toutes ces années d'expérience.

We always cooperate closely with our global team and our customers. Thus we are able to achieve goals faster, realize large concepts and fulfill individual customer requests.

Our components and robotics, manufactured in-house, provide first-class quality and are the basis for technologically advanced solutions for automation and integrated systems. They are used mainly in materials handling, the manufacturing sector, energy production and logistics.

As customer-oriented service provider, we consider each order to be the start of a long-term partnership. Our customers benefit from a full scope of services. This has been our philosophy for more than 50 years.

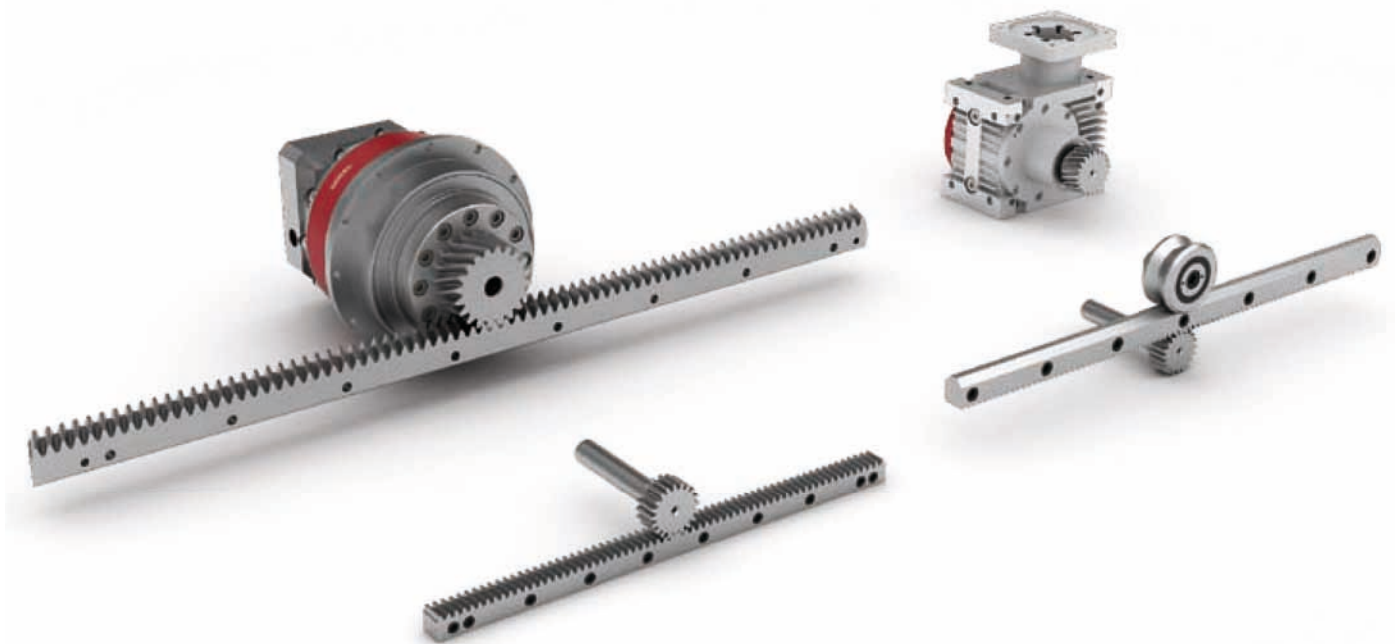

Wir bauen auf Komponenten

Unsere Komponenten der Linear- und Antriebstechnik, die wir in diesem Katalog vorsehen, bilden die Basis in unserem Baukastensystem. Mit ihnen verknüpfen wir Robotik und schaffen technologisch anspruchsvolle Lösungen für die Automation und integrierte Systeme.

Da wir hohe Qualitätsansprüche stellen, investieren wir in die Zukunft, entwickeln und konstruieren selbst und produzieren unsere Komponenten im eigenen Werk an modernsten Maschinen. Zusammen mit unserer jahrzehntelangen Erfahrung in Längsführungen, Verzahnungen und Getriebebau haben wir ein umfangreiches und hochwertiges Standardprogramm geschaffen, welches wir Ihnen auf den kommenden Seiten präsentieren möchten.

Nous misons sur nos composants

Les composants des systèmes de guidage linéaire et d'entraînement que nous présentons dans ce catalogue constituent la base du système modulaire que nous développons. En les combinant avec la robotique, nous créons des solutions technologiques complexes destinées aux domaines de l'automatisation et des systèmes intégrés.

Afin de garantir une qualité élevée constante, nous investissons dans l'avenir, développons, fabriquons nous-mêmes et produisons nos composants dans nos propres usines à l'aide des machines les plus modernes. La gamme de guidages longitudinaux, de dentures et de réducteurs que nous vous présentons ici est le fruit de ces cinq décennies d'expérience dont nous souhaitons vous faire profiter.

Components are our strength

The components for linear and drive technology presented in this catalog form the basis of our modular system. We combine these with robotics to create technologically advanced solutions for automation and integrated systems.

We have high quality standards; therefore we invest in the future, develop and engineer our own products and produce our components in our own factory, on state-of-the-art machines. We have many decades of experience in linear guideways, tooth systems and gearbox engineering, which we have combined to create an extensive, high-quality standard program that we want to present to you on the coming pages.

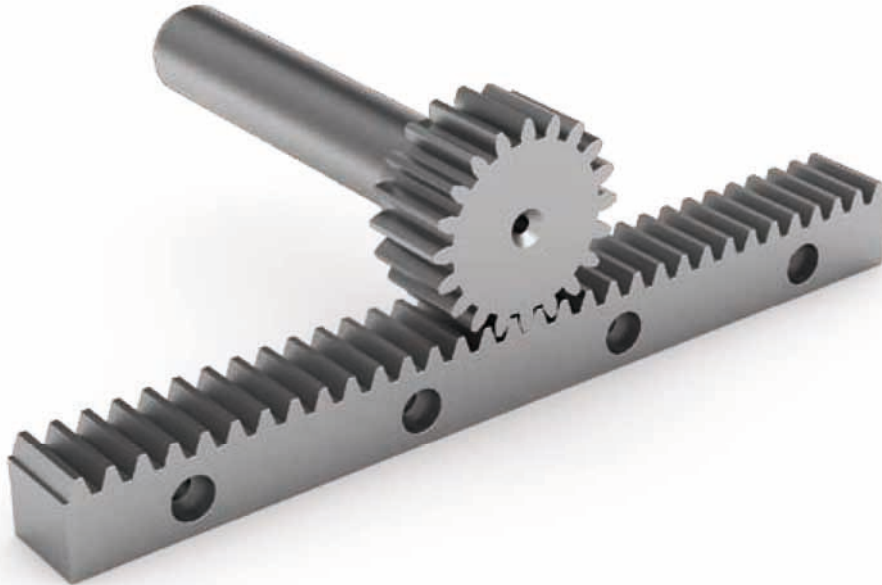

Ritzel & Zahnstangen nach Mass

Wir bieten unsere Ritzel und Zahnstangen in verschiedenen Ausführungen und Qualitäten an, können aber auch Sonderanfertigungen auf Kundenwunsch realisieren. Das ermöglicht uns passgenaue Produkte für jede Branche und Anwendung bereitzustellen.

In den Qualitäten:

- | 4 gehärtet und geschliffen
- | 5 gehärtet und geschliffen
- | 6 gehärtet und geschliffen
- | 7/8 feinstverzahnt
- | 9 feinstverzahnt und gehärtet

stehen drei Ausführungen zur Verfügung:

- | Gerade verzahnt, Modulteilung
- | Schräg verzahnt, Modulteilung
- | Gerade verzahnt, metrische Teilung

Pignons et crémaillères sur mesure

Nos pignons et crémaillères sont disponibles dans différentes exécutions et qualités, mais peuvent également être réalisés sur mesure, selon vos besoins. Ainsi, nous sommes en mesure de proposer des produits adaptés à chaque branche et à chaque application.

Qualités disponibles :

- | 4 Trempée et rectifiée
- | 5 Trempée et rectifiée
- | 6 Trempée et rectifiée
- | 7/8 coupe de précision
- | 9 coupe de précision et trempée

Trois modèles sont disponibles pour chaque qualité :

- | Denture droite, pas modulaire
- | Denture oblique, pas modulaire
- | Denture droite, pas métrique

Tailor-made racks and pinions

Our racks and pinions are available in various designs and qualities, but we can also produce custom-made models on request. Thus we can provide products that are perfectly tailored to each industry and application.

Qualities available:

- | 4 Hardened and ground
- | 5 Hardened and ground
- | 6 Hardened and ground
- | 7/8 Precision-cut
- | 9 Precision-cut and hardened

Three versions are available in each quality:

- | Straight teeth, modular pitch
- | Helical teeth, modular pitch
- | Straight teeth, metric pitch



GÜDEL GROUP

Europe

| Switzerland – Headquarter
GÜDEL AG
Industrie Nord
CH-4900 Langenthal
Phone +41 62 916 91 91
info@ch.gudel.com

| Benelux
GÜDEL AG
Echelpoelweg 1b
NL-7595 KA Weerselo
phone +31 541 66 22 50
fax +31 541 66 18 74
info@nl.gudel.com

| France
GÜDEL France
Phone +33 1 30091545
info@fr.gudel.com

| Grossbritannien
GÜDEL Lineartec UK Ltd
5 Wickmans drive | West Midlands
GB-Coventry CV4 9XA
Phone +44 24 7669 5444
info@uk.gudel.com

| Österreich
GÜDEL GmbH
Schöneringer Str. 48
A-4073 Wilhering
Phone +43 7226 20690-0
info@at.gudel.com

| Polen
GÜDEL Sp. z o.o.
Ul. Karpacka 24/4
43-316 Bielsko-Biala
Phone +48 33 819 01 25
info@pl.gudel.com

| Spanien
GÜDEL AG
C/ Industria 60 | Local 7
ES-08025 Barcelona
Phone +34 93 476 03 80
info@es.gudel.com

| Deutschland
GÜDEL GmbH
Carl-Benz-Strasse 5
D-63674 Albstadt
Phone +49 6047 9639 0
info@de.gudel.com

| techCenter
Rosenberger Str. 1
D-74706 Osterburken
Phone +49 6291 6446 0
info@de.gudel.com

| Italien
GÜDEL Srl
Strada Per Cernusco nr. 7
IT-20060 Bussero (MI)
Phone +39 02 9217021
info@it.gudel.com

| Tschechische Republik
GÜDEL a.s.
Vrbice 27
Holandská 4
CZ-63900 Brno
Phone +420 519 323 431
info@gudel.cz



www.gudel.com

North- / South-America

| Brasilien

GÜDEL do Brasil

Rua Américo Brasiliense, 2171
cj. 506
São Paulo - SP - Brasil
Phone +55 11 5182 3378
info@br.gudel.com

| USA

GÜDEL Inc.

4881 Runway Blvd.
US-Ann Arbor, MI 48108
Marker Karte anzeigen
Phone +1 734 214 0000
info@us.gudel.com

| Mexiko

GÜDEL TSC

Gustavo M. Garcia 308
Col. Buenos Aires
Monterrey, N.L. Mexico 64490
Phone +52 (81) 8374-2500
info@mx.gudel.com

Asia

| China

GÜDEL International Trading

(Shanghai) Co., Ltd.
3506 The King Tower
28 New Jinqiao Road, Pudong
Shanghai 201206, China
Phone +86 21 5055 0012
info@cn.gudel.com

| Indien

GÜDEL India Pvt. Ltd

14, Commerce Avenue
Mahaganesh Colony, Paud Road
Pune - 411038
Phone +91 20 25459531
info@in.gudel.com

| Südkorea

GÜDEL Lineartec Inc.

11-22 Songdo-dong, Yeonsu-Ku, Incheon
City, Republic of Korea
Post no. 406-840
Phone +82 32 858 0541
info@kr.gudel.com

| Taiwan

GÜDEL Lineartec Co. Ltd.

No. 99, An-Chai 8th St.
Hsin-Chu Industrial Park
TW-Hu-Ko, Hsin-Chu, Taiwan
Phone +88 635 97 8808
info@tw.gudel.com

| Singapore

GÜDEL PTE LTD.

Reg. Office: #04-48
101 Upper Cross Street
Singapore 058 357
Phone +65 - 6567 4572

Find **GÜDEL** also in: Finnland, Israel, Norwegen, Schweden, Türkei, Australia und Indonesien.

Piktogramme

Icône

Icon

Legende

Légende

Legend

Produktgruppe / Groupe de Produits / Product Group



Zahnstange / Crémaillères / Rack



Ritzel / Pignons / Pinion



Zahnstange rund / Crémaillères ronde / Rack roundes



Wellenritzel / Pignon avec arbre / Pinion with shaft

Qualität / Qualité / Quality



Material / matériaux / material



Stahl / Acier / Steel



Rostfrei / Inox / Stainless



Kunststoff / Polyamide / Polyamide

Verzahnung / Denture / Tooth type



Gerade verzahnt / Denture droite / Straight teeth



Schräg verzahnt / Denture oblique / Helical teeth

Bearbeitung / Usinage / Processes



Gehärtet / Trempeée / Hardened



Geschliffen / Rectifiée / Ground



Ballig geschliffen / Rectifiée bombée / Ground crowned



Feinstverzahnt / Coupe de précision / Precision cut



Gefräst / Fraisées / Milled

Inhaltsverzeichnis

Table des Matières

Table of Content

Zahnstangen und Wellenritzel

Crémaillères pignons

Rack and pinion

						Module	Reihe / Série / Series	Qualität / Qualité / Quality	Seite / Page / Page
	Q4					2.0 - 10.0	240...	Q4 h21	13
	Q5					2.0 - 10.0	240...	Q5 h22	14
	Q6					1.5 - 10.0	244...	Q6 h23	15
	Q6					1.5 - 10.0	240...	Q6 h23	16
	Q6					1.5 - 6.0	14...	Q6 f24	17-20
	Q6					1.0 - 10.0	201...	Q6 f24	21
	Q6					1.5 - 10.0	254...	Q6 f24	22
	Q4					2.0 - 10.0	246...	Q4 h21	23
	Q5					2.0 - 10.0	246...	Q5 h22	24
	Q6					1.5 - 10.0	244...	Q6 h23	25
	Q6					1.5 - 10.0	246...	Q6 h23	26
	Q6					1.5 - 6.0	14...	Q6 f24	27-30
	Q6					1.5 - 10.0	211...	Q6 f24	31
	Q6					1.5 - 10.0	254...	Q6 f24	32-33
	Q6					0.637 - 3.183	170...	Q6 h23	34
	Q6					0.637 - 3.183	900...	Q6 f24	35
	Q6					0.637 - 6.366	4....	Q6 f24	36
	Q6					0.637 - 7.958	154...	Q6 f24	37-38
	Q7					0.637 - 3.979	151...	Q7 h25	39
	Q7					0.637 - 3.979	152...	Q7 h25	39
	Q7					0.637 - 3.183	153...	Q7 h25	40
	Q7					1.0 - 6.0	126...	Q7 h25	41
	Q8					1.0 - 8.0	124...	Q8 h27	42
	Q8					1.0 - 6.0	123...	Q8 h27	43
	Q8					1.0 - 5.0	131...	Q8 h27	44
	Q9					3.183 - 7.958	903...	Q9 h25	45
	Q9					1.5 - 6.0	124...	Q9 h27	46
	Q9					1.0 - 5.0	127...	Q9 h27	47
	Q9					1.0 - 5.0	130...	Q9 h27	48-49
Berechnungsbeispiel / Exemple de calcul / Calculation Example									51-52
Wartung und Schmierung / Entretien et Lubrification / Maintenance and lubrication									53-54
Einbau und Ausbau / Montage / Assembly									55-57

Produkteübersicht Ritzel und Zahnstangen

Gamme des produits

Product overview racks and pinions

Elemente

Éléments

Elements



Auswahl- und Belastungstabelle

Tableaux de sélection et des caractéristiques

Selection and load tables for rack and pinion drives

Geradeverzahnt, Modulteilung

Denture droite, à module

Straight tooth, modular pitch

p (mm)	Teilung, pas, pitch	3.14	4.71	6.28	7.85	9.42	12.56	15.71	18.84	25.12	31.461
m (mm)	Module	1.0	1.5	2.0	2.5	3.0	4.0	5.0	6.0	8.0	10.0

Die Verzahnungen sind in weicher sowie gehärteter und geschliffener Ausführung lieferbar.

Die angegebenen Werte haben Gültigkeit bei guter Schmierung, stossfreiem Betrieb und stabiler Lagerung.

Ein Sicherheitsfaktor für Zahnfußbeanspruchung $S_F \geq 1.4$ und ein Sicherheitsfaktor für Zahnflankenbeanspruchung $S_H \geq 1.0$ ist einberechnet.

Ein Sicherheitsfaktor $S_B \approx 1.0 \dots 4.0$ ist nach Erfahrung zu berücksichtigen.

Die Längskraft FN ist in Abhängigkeit von der Zähnezahl z des Ritzels angegeben.

Les dentures peuvent être livrées aussi bien en version non-trempée qu'en version trempée et rectifiée. Les valeurs indiquées sont des valeurs obtenues en fonctionnement sans chocs, avec lubrification et montage rigide du pignon. Un coefficient de sécurité pour la contrainte de flexion $S_F \geq 1.4$ et un coefficient de sécurité pour la pression superficielle $S_H \geq 1.0$ sont respectés.

Un coefficient de sécurité $S_B \approx 1.0 \dots 4.0$ doit être intégré en fonction de l'application.

La force de traction FN est indiquée en fonction du nombre de dents z du pignon.

The rack can be supplied precision cut or hardened and ground.

The values given are values for shock-free operation, good lubrication and stiff arrangement of the pinion.

A safety factor for tooth root stress $S_F \geq 1.4$ and a safety factor for Hertzian stress $S_H \geq 1.0$ is taken in account.

Depending on your experiences and the application a safety factor $S_B \approx 1.0 \dots 4.0$ has to be considered. The traction force FN is related to the number of teeth z of the pinion.

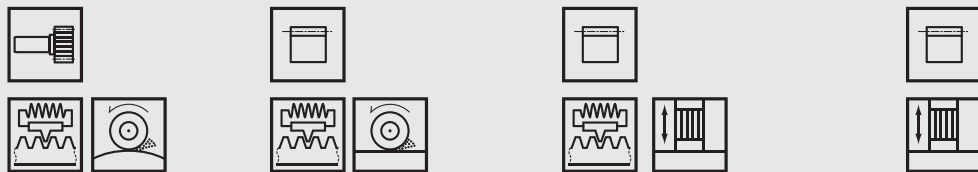
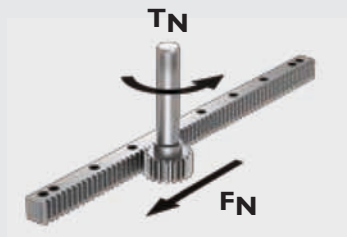

p	Modul	z	L ₂	FN [N]	TN [Nm]	FN [N]	TN [Nm]	FN [N]	TN [Nm]
3.142	1.0	25	9.5	970	12				
3.142	1.0	20	15					386	3.9
4.712	1.5	16	20	2 888	35	1 370	16	532	6.4
4.712	1.5	20	20	3 638	55	1 497	22	668	10
6.283	2.0	16	20	4 810	77	2 583	41	845	14
6.283	2.0	20	20	5 958	119	2 907	58	1 063	21
7.854	2.5	20	25	9 004	225	4 836	121	1 601	40
9.425	3.0	16	30	12 597	302	7 328	176	1 846	44
9.425	3.0	20	30	13 697	411	7 450	224	2 326	70
12.566	4.0	20	40	24 068	963	14 639	586	4 519	181
15.708	5.0	20	50	37 317	1 866	27 905	1 395	7 606	380
18.850	6.0	20	60	52 880	3 173	41 797	2 508	11 854	711
25.133	8.0	20	80	91 220	7 298			23 103	1 848
31.416	10.0	16	100	137 151	10 972				
31.416	10.0	20	100	138 643	13 864				

L₂: Zahnbreite / largeur de denture / face width

Auswahl- und Belastungstabelle

Tableaux de sélection et des caractéristiques

Selection and load tables for rack and pinion drives

Schrägverzahnt, Moduleteilung

Denture oblique, à module

helical tooth, modular pitch

p (mm)	Teilung, pas, pitch	5.00	6.66	8.33	10.00	13.33	16.66	20.00	26.66	33.33
m (mm)	Module	1.5	2.0	2.5	3.0	4.0	5.0	6.0	8.0	10.0

Die Verzahnungen sind in weicher sowie gehärteter und geschliffener Ausführung lieferbar.

Die angegebenen Werte haben Gültigkeit bei guter Schmierung, stossfreiem Betrieb und stabiler Lagerung.

Ein Sicherheitsfaktor für Zahnfußbeanspruchung $S_F \geq 1.4$ und ein Sicherheitsfaktor für Zahnflankenbeanspruchung $S_H \geq 1.0$ ist einberechnet.

Ein Sicherheitsfaktor $S_B \approx 1.0 \dots 4.0$ ist nach Erfahrung zu berücksichtigen.

Die Längskraft F_N ist in Abhängigkeit von der Zähnezahl z des Ritzels angegeben.

Les dentures peuvent être livrées aussi bien en version non-trempée qu'en version trempée et rectifiée. Les valeurs indiquées sont des valeurs obtenues en fonctionnement sans chocs, avec lubrification et montage rigide du pignon.

Un coefficient de sécurité pour la contrainte de flexion $S_F \geq 1.4$ et un coefficient de sécurité pour la pression superficielle $S_H \geq 1.0$ sont respectés.

Un coefficient de sécurité $S_B \approx 1.0 \dots 4.0$ doit être intégré en fonction de l'application.

La force de traction F_N est indiquée en fonction du nombre de dents z du pignon.

The rack can be supplied precision cut or hardened and ground.

The values given are values for shock-free operation, good lubrication and stiff arrangement of the pinion. A safety factor for tooth root stress $S_F \geq 1.4$ and a safety factor for Hertzian stress $S_H \geq 1.0$ is taken in account.

Depending on your experiences and the application a safety factor $S_B \approx 1.0 \dots 4.0$ has to be considered.

The traction force F_N is related to the number of teeth z of the pinion.

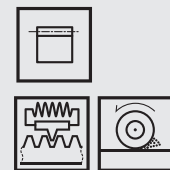
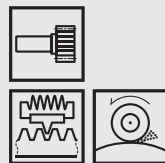
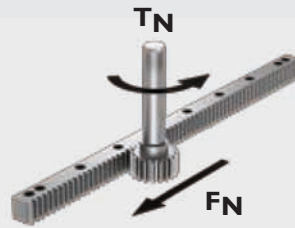

PS	Modul	z	L ₂	F _N (N)	T _N (Nm)
5.00	1.5	16	20.0	3 178	41
5.00	1.5	20	20.0	4 237	67
6.66	2.0	16	20.0	5 417	92
6.66	2.0	20	20.0	6 528	139
8.33	2.5	20	25.0	10 363	275
10.00	3.0	16	30.0	13 589	346
10.00	3.0	20	30.0	15 180	483
13.33	4.0	20	40.0	28 394	1 205
16.66	5.0	20	50.0	44 963	2 385
20.00	6.0	20	60.0	64 990	4 137
26.66	8.0	20	80.0	114 380	9 709
33.33	10.0	20	100.0	175 005	18 569
33.33	10.0	15	100.0	160 516	12 773

L₂: Zahnbreite / largeur de denture / face width

Auswahl- und Belastungstabelle

Tableaux de sélection et des caractéristiques

Selection and load tables for rack and pinion drives

Geradeverzahnt, metrische Teilung Denture droite, à pas métrique Straight tooth, metric pitch

p (mm)	Teilung, pas, pitch	2.00	5.0	7.5	10.0	12.5	16.0	20.00	25.0
m (mm)	Module	0.637	1.592	2.387	3.183	3.979	5.093	6.366	7.958

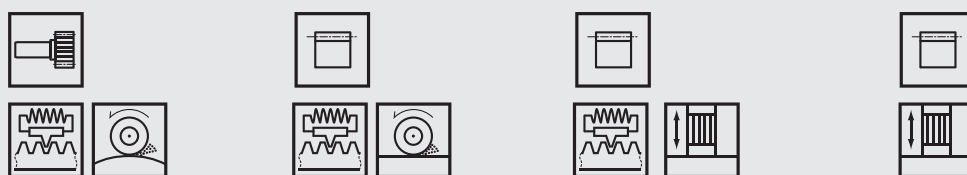
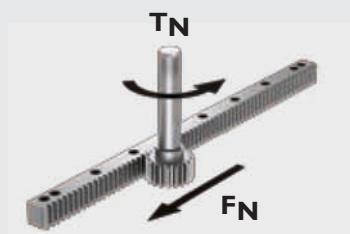

p	Modul	z	L ₂	FN [N]	TN [Nm]	FN [N]	TN [Nm]	FN [N]	TN [Nm]
2.0	0.637	25	9.5	80	0.64			76	0.6
2.0	0.637	30	9.5	100	0.95			95	0.9
5.0	1.592	20	11.5	2 488	40			733	11.7
5.0	1.592	20	14.5	3 098	49			925	15
7.5	2.387	20	19.5	6 946	166			1 958	47
10.0	3.183	14	29.5	11 095	247	5 997	134	2 644	59
10.0	3.183	20	29.5	14 774	470	7 844	250	4 340	138
12.5	3.979	14	40.0			11 300	315	3 225	90
12.5	3.979	20	40.0			14 145	563	5 108	203
12.5	3.979	26	40.0			14 189	734	7 109	368
16.0	5.093	20	50.0			27 058	1 378		
20.0	6.366	20	60.0			42 719	2 720		
25.0	7.958	20	80.0			76 558	6 092		

L₂: Zahnbreite / largeur de denture / face width

Gerade verzahnt, Modulteilung

Dentures droites, à pas Module

Straight tooth, Modular pitch

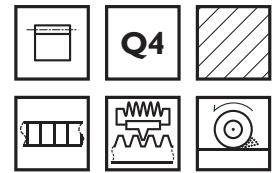

Gehärtet und geschliffen

Material: C45E DIN 1.1191
Profil: allseitig geschliffen
Zahnung: Eingriffswinkel $\alpha = 20^\circ$
 gehärtet (ca. HRC 56)
 und geschliffen
Qualität: 4h21 DIN 3962/63/67
 f_p (mm): Teilungs-Einzelabweichung
 Modul ≤ 3 ; 0.003
 Modul > 3 ; 0.005
 p_f (mm): Toleranz der teilungsgenauen
 Ablängung -0.05/-0.2
 F_{pL} (mm): bezogen auf Länge L
 F_{p250} bezogen auf Länge 250mm
 Teilungs-Gesamtabweichung

Trempées et rectifiées

Matière: C45E DIN 1.1191
Profil: réctifiée toutes les faces
Denture: angle de pression $\alpha = 20^\circ$
 trempée (ca. HRC 56)
 et rectifiée
Qualité: 4h21 DIN 3962/63/67
 f_p (mm): Erreur individuelle de pas
 Modul ≤ 3 ; 0.003
 Modul > 3 ; 0.005
 p_f (mm): Tolérance de coupe par rapport
 au pas -0.05/-0.2
 F_{pL} (mm): basée sur la longueur L
 F_{p250} basée sur la longueur 250mm
 Erreur totale de pas

Hardened and ground

Material: C45E DIN 1.1191
Profil: all faces ground
Teeth: pressure angle $\alpha = 20^\circ$
 hardened (ca. HRC 56)
 and ground
Quality: 4h21 DIN 3962/63/67
 f_p (mm): Adjacent pitch error
 Modul ≤ 3 ; 0.003
 Modul > 3 ; 0.005
 p_f (mm): Tolerance of cut for continuous
 mounting -0.05/-0.2
 F_{pL} (mm): based on length L
 F_{p250} based on length 250mm
 Cumulative pitch error

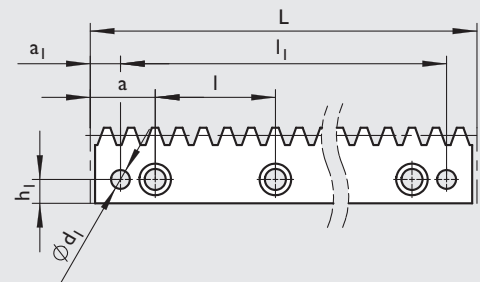
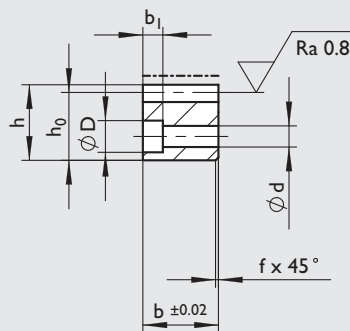

Part-No.	p	Modul	L	z	b	h	h ₀	f ^{+0.5}	a	l	h ₁	d	D	b ₁	a ₁	l ₁	d ₁	F _{pL}	F _{p250}	m(kg)
240012-Q4	4.712	1.5	499.51	106	19	19	17.5 0/-0.011	2	62.44	124.88	8	7	11	7	29	441.5	5.7	0.016	0.012	1.3
240013-Q4	4.712	1.5	999.03	212	19	19	17.5 0/-0.011	2	62.44	124.88	8	7	11	7	29	941.0	5.7	0.025	0.012	2.6
240022-Q4	6.283	2	502.65	80	24	24	22.0 0/-0.011	2	62.83	125.66	8	7	11	7	31.3	440.1	5.7	0.014	0.011	2.1
240023-Q4	6.283	2	1005.31	160	24	24	22.0 0/-0.011	2	62.83	125.66	8	7	11	7	31.3	942.7	5.7	0.021	0.011	4.2
240032-Q4	7.854	2.5	502.65	64	24	24	21.5 0/-0.011	2	62.83	125.66	9 _w	7	11	7	31.3	440.1	5.7	0.014	0.011	2.0
240033-Q4	7.854	2.5	1005.31	128	24	24	21.5 0/-0.011	2	62.83	125.66	9	7	11	7	31.3	942.7	5.7	0.018	0.011	4.1
240042-Q4	9.425	3	508.94	54	29	29	26.0 0/-0.014	2	63.62	127.23	9	10	15	9	34.4	440.1	7.7	0.015	0.013	3.0
240043-Q4	9.425	3	1017.88	108	29	29	26.0 0/-0.014	2	63.62	127.23	9	10	15	9	34.4	949.1	7.7	0.019	0.013	6.0
240052-Q4	12.566	4	502.65	40	39	39	35.0 0/-0.014	2	62.83	125.66	12	10	15	9	37.5	427.7	7.7	0.016	0.015	5.4
240053-Q4	12.566	4	1005.31	80	39	39	35.0 0/-0.014	2	62.83	125.66	12	10	15	9	37.5	930.3	7.7	0.019	0.015	10.8
240062-Q4	15.708	5	502.65	32	49	39	34.0 0/-0.014	3	62.83	125.66	12	14	20	13	30.2	442.3	11.7	0.015	0.014	6.6
240063-Q4	15.708	5	1005.31	64	49	39	34.0 0/-0.014	3	62.83	125.66	12	14	20	13	30.2	944.9	11.7	0.018	0.014	13.3
240072-Q4	18.850	6	508.94	27	59	49	43.0 0/-0.014	3	63.62	127.23	16	18	26	17	31.4	446.1	15.7	0.015	0.014	10.1
240073-Q4	18.850	6	1017.88	54	59	49	43.0 0/-0.016	3	63.62	127.23	16	18	26	17	31.4	955	15.7	0.018	0.014	20.3
240082-Q4	25.133	8	502.65	20	79	79	71.0 0/-0.016	3	62.83	125.66	25	22	33	21	26.7	449.3	19.7	0.017	0.016	22.1
240083-Q4	25.133	8	1005.31	40	79	79	71.0 0/-0.016	3	62.83	125.66	25	22	33	21	26.7	952	19.7	0.019	0.016	44.3
240092-Q4	31.416	10	502.65	16	99	99	89.0 0/-0.016	3	62.83	125.66	32	33	48	32	125.2	252.3	19.7	0.016	0.016	34.8
240093-Q4	31.416	10	1005.31	32	99	99	89.0 0/-0.016	3	62.83	125.66	32	33	48	32	125.2	755	19.7	0.018	0.016	69.5

p (mm): Teilung / graduation / pitch

z: Zähnezahl / nom de dents / number of teeth

d₁: vorgebohrt / préperçé / predrilled

Gerade verzahnt, Modulteilung

Dentures droites, à pas Module

Straight tooth, Modular pitch

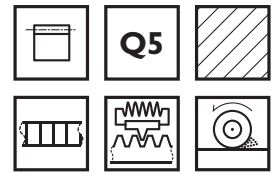

Gehärtet und geschliffen

Material: C45E DIN 1.1191
Profil: allseitig geschliffen
Zahnung: Eingriffswinkel $\alpha = 20^\circ$
 gehärtet (ca. HRC 56)
 und geschliffen
Qualität: 5h22 DIN 3962/63/67
 f_p (mm): Teilungs-Einzelabweichung
 Modul ≤ 3 ; 0.004
 Modul > 3 ; 0.006
 p_f (mm): Toleranz der teilungsgenauen
 Ablängung -0.05/-0.2
 F_{pL} (mm): bezogen auf Länge L
 F_{p250} bezogen auf Länge 250mm
 Teilungs-Gesamtabweichung

Trempées et rectifiées

Matière: C45E DIN 1.1191
Profil: réctifiée toutes les faces
Denture: angle de pression $\alpha = 20^\circ$
 trempée (ca. HRC 56)
 et rectifiée
Qualité: 5h22 DIN 3962/63/67
 f_p (mm): Erreur individuelle de pas
 Modul ≤ 3 ; 0.004
 Modul > 3 ; 0.006
 p_f (mm): Tolérance de coupe par rapport
 au pas -0.05/-0.2
 F_{pL} (mm): basée sur la longueur L
 F_{p250} basée sur la longueur 250mm
 Erreur totale de pas

Hardened and ground

Material: C45E DIN 1.1191
Profil: all faces ground
Teeth: pressure angle $\alpha = 20^\circ$
 hardened (ca. HRC 56)
 and ground
Quality: 5h22 DIN 3962/63/67
 f_p (mm): Adjacent pitch error
 Modul ≤ 3 ; 0.004
 Modul > 3 ; 0.006
 p_f (mm): Tolerance of cut for continuous
 mounting -0.05/-0.2
 F_{pL} (mm): based on length L
 F_{p250} based on length 250mm
 Cumulative pitch error

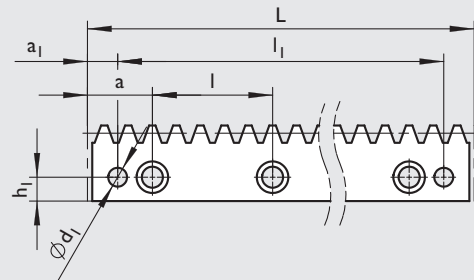
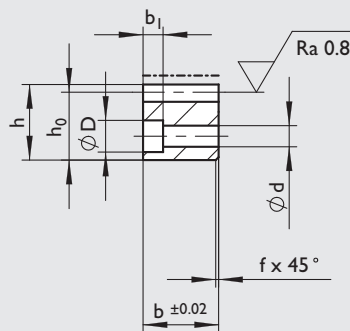

Part-No.	p	Modul	L	z	b	h	h ₀	f ^{+0.5}	a	l	h ₁	d	D	b ₁	a ₁	l ₁	d ₁	F _{pL}	F _{p250}	m(kg)	
240022-Q5	6.283	1.5	499.51	106	19	19	17.5	0/-0.011	2	62.44	124.88	8	7	11	7	29	441.5	5.7	0.021	0.016	1.3
240023-Q5	6.283	1.5	999.03	212	19	19	17.5	0/-0.011	2	62.44	124.88	8	7	11	7	29	941.0	5.7	0.030	0.016	2.6
240022-Q5	6.283	2	502.65	80	24	24	22.0	0/-0.020	2	62.83	125.66	8	7	11	7	31.3	440.1	5.7	0.018	0.014	2.1
240023-Q5	6.283	2	1005.31	160	24	24	22.0	0/-0.020	2	62.83	125.66	8	7	11	7	31.3	942.7	5.7	0.025	0.014	4.2
240032-Q5	7.854	2.5	502.65	64	24	24	21.5	0/-0.020	2	62.83	125.66	9	7	11	7	31.3	440.1	5.7	0.019	0.016	2.0
240033-Q5	7.854	2.5	1005.31	128	24	24	21.5	0/-0.020	2	62.83	125.66	9	7	11	7	31.3	942.7	5.7	0.025	0.016	4.1
240042-Q5	9.425	3	508.94	54	29	29	26.0	0/-0.020	2	63.62	127.23	9	10	15	9	34.4	440.1	7.7	0.020	0.017	3.0
240043-Q5	9.425	3	1017.88	108	29	29	26.0	0/-0.020	2	63.62	127.23	9	10	15	9	34.4	949.1	7.7	0.026	0.017	6.0
240052-Q5	12.566	4	502.65	40	39	39	35.0	0/-0.020	2	62.83	125.66	12	10	15	9	37.5	427.7	7.7	0.021	0.019	5.4
240053-Q5	12.566	4	1005.31	80	39	39	35.0	0/-0.020	2	62.83	125.66	12	10	15	9	37.5	930.3	7.7	0.026	0.019	10.8
240062-Q5	15.708	5	502.65	32	49	39	34.0	0/-0.022	3	62.83	125.66	12	14	20	13	30.2	442.3	11.7	0.020	0.018	6.6
240063-Q5	15.708	5	1005.31	64	49	39	34.0	0/-0.022	3	62.83	125.66	12	14	20	13	30.2	944.9	11.7	0.024	0.018	13.3
240072-Q5	18.850	6	508.94	27	59	49	43.0	0/-0.022	3	63.62	127.23	16	18	26	17	31.4	446.1	15.7	0.022	0.020	10.1
240073-Q5	18.850	6	1017.88	54	59	49	43.0	0/-0.022	3	63.62	127.23	16	18	26	17	31.4	955	15.7	0.026	0.020	20.3
240082-Q5	25.133	8	502.65	20	79	79	71.0	0/-0.022	3	62.83	125.66	25	22	33	21	26.7	449.3	19.7	0.021	0.020	22.1
240083-Q5	25.133	8	1005.31	40	79	79	71.0	0/-0.022	3	62.83	125.66	25	22	33	21	26.7	952	19.7	0.024	0.020	44.3
240092-Q5	31.416	10	502.65	16	99	99	89.0	0/-0.022	3	62.83	125.66	32	23	48	32	125.2	252.3	19.7	0.020	0.019	34.8
240093-Q5	31.416	10	1005.31	32	99	99	89.0	0/-0.022	3	62.83	125.66	32	23	48	32	125.2	755	19.7	0.023	0.019	69.5

p (mm): Teilung / graduation / pitch

z: Zähnezahl / nom de dents / number of teeth

d₁: vorgebohrt / préperçé / predrilled

Gerade verzahnt, Modulteilung Dentures droites, à pas Module Straight tooth, Modular pitch

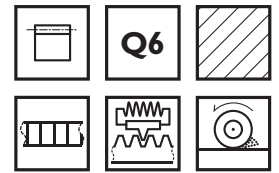

Gehärtet und geschliffen

Material: C45E DIN 1.1191
Profil: allseitig geschliffen
Zahnung: Eingriffswinkel $\alpha = 20^\circ$
 gehärtet (ca. HRC 56)
 und geschliffen
Qualität: 6h23 DIN 3962/63/67
 f_p (mm): Teilungs-Einzelabweichung
 Modul ≤ 3 ; 0.006
 Modul > 3 ; 0.008
 p_f (mm): Toleranz der teilungsgenauen
 Ablängung -0.05/-0.2
 F_p Teilungs-Gesamtabweichung

Trempees et rectifiées

Matière: C45E DIN 1.1191
Profil: réctifiée toutes les faces
Denture: angle de pression $\alpha = 20^\circ$
 trempée (ca. HRC 56)
 et rectifiée
Qualité: 6h23 DIN 3962/63/67
 f_p (mm): Erreur individuelle de pas
 Modul ≤ 3 ; 0.006
 Modul > 3 ; 0.008
 p_f (mm): Tolérance de coupe par rapport
 au pas -0.05/-0.2
 F_p Erreur totale de pas

Hardened and ground

Material: C45E DIN 1.1191
Profil: all faces ground
Teeth: pressure angle $\alpha = 20^\circ$
 hardened (ca. HRC 56)
 and ground
Quality: 6h23 DIN 3962/63/67
 f_p (mm): Adjacent pitch error
 Modul ≤ 3 ; 0.006
 Modul > 3 ; 0.008
 p_f (mm): Tolerance of cut for continuous
 mounting -0.05/-0.2
 F_p Cumulative pitch error

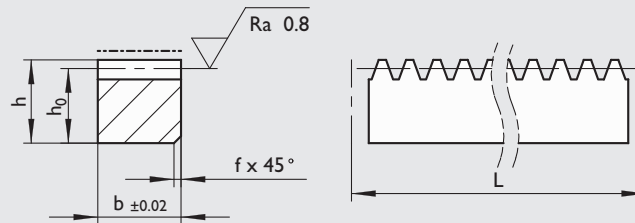
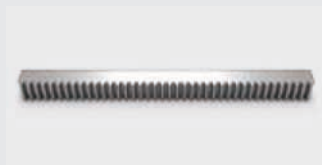

Option: 1.7131 (16MnCr5)

Part No.	p	Modul	L	z	b	h	h ₀	f _{+0.5}	F _p	m(kg)
244512	4.712	1.5	499.51	106	19	19	17.50	2	0.029	1.3
244513	4.712	1.5	999.03	212	19	19	17.50	2	0.043	2.6
244522	6.283	2.0	502.65	80	24	24	22.00	2	0.025	2.1
244523	6.283	2.0	1005.31	160	24	24	22.00	2	0.036	4.2
244532	7.854	2.5	502.65	64	24	24	21.50	2	0.027	2.0
244533	7.854	2.5	1005.31	128	24	24	21.50	2	0.036	4.1
244542	9.425	3.0	508.94	54	29	29	26.00	2	0.029	3.0
244543	9.425	3.0	1017.88	108	29	29	26.00	2	0.037	6.0
244552	12.566	4.0	502.65	40	39	39	35.00	2	0.030	5.4
244553	12.566	4.0	1005.31	80	39	39	35.00	2	0.037	10.8
244562	15.708	5.0	502.65	32	49	39	34.00	3	0.028	6.6
244563	15.708	5.0	1005.31	64	49	39	34.00	3	0.034	13.1
244572	18.850	6.0	508.94	27	59	49	43.00	3	0.031	10.1
244573	18.850	6.0	1017.88	54	59	49	43.00	3	0.036	20.3
244582	25.133	8.0	502.65	20	79	79	71.00	3	0.029	22.1
244583	25.133	8.0	1005.31	40	79	79	71.00	3	0.033	44.3
244592	31.461	10.0	502.65	16	99	99	89.00	3	0.029	34.8
244593	31.461	10.0	1005.31	32	99	99	89.00	3	0.032	69.5

p (mm): Teilung / graduation / pitch

z: Zähnezahl / nom de dents / number of teeth

Gerade verzahnt, Modulteilung

Dentures droites, à pas Module

Straight tooth, Modular pitch

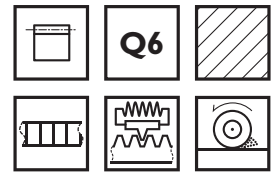

Gehärtet und geschliffen

Material: C45E DIN 1.1191
Profil: allseitig geschliffen
Zahnung: Eingriffswinkel $\alpha = 20^\circ$
 gehärtet (ca. HRC 56)
 und geschliffen
Qualität: 6h23 DIN 3962/63/67
 f_p (mm): Teilungs-Einzelabweichung
 Modul ≤ 3 ; 0.006
 Modul > 3 ; 0.008
 p_f (mm): Toleranz der teilungsgenauen
 Ablängung -0.05/-0.2
 F_{pL} (mm): bezogen auf Länge L
 Teilungs-Gesamtabweichung

Trempées et rectifiées

Matière: C45E DIN 1.1191
Profil: réctifiée toutes les faces
Denture: angle de pression $\alpha = 20^\circ$
 trempée (ca. HRC 56)
 et rectifiée
Qualité: 6h23 DIN 3962/63/67
 f_p (mm): Erreur individuelle de pas
 Modul ≤ 3 ; 0.006
 Modul > 3 ; 0.008
 p_f (mm): Tolérance de coupe par rapport
 au pas -0.05/-0.2
 F_{pL} (mm): basée sur la longueur L
 Erreur totale de pas

Hardened and ground

Material: C45E DIN 1.1191
Profil: all faces ground
Teeth: pressure angle $\alpha = 20^\circ$
 hardened (ca. HRC 56)
 and ground
Quality: 6h23 DIN 3962/63/67
 f_p (mm): Adjacent pitch error
 Modul ≤ 3 ; 0.006
 Modul > 3 ; 0.008
 p_f (mm): Tolerance of cut for continuous
 mounting -0.05/-0.2
 F_{pL} (mm): based on length L
 Cumulative pitch error



Option: 1.7131 (16MnCr5)

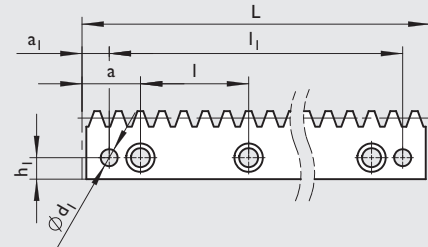
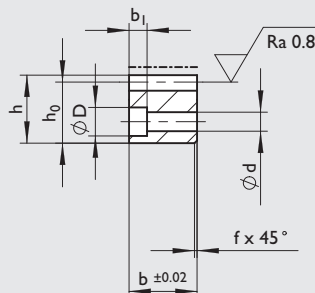

Part No.	p	Modul	L	z	b	h	h_0	$f^{*0.5}$	a	l	h_1	d	D	b_1	a_1	l_1	d_1	F_{pL}	m(kg)
240012	4.712	1.5	499.51	106	19	19	17.50 0/-0.27	2	62.44	124.88	8	7	11	7	29.0	441.5	5.7	0.029	1.3
240013	4.712	1.5	999.03	212	19	19	17.50 0/-0.27	2	62.44	124.88	8	7	11	7	29.0	941.0	5.7	0.043	2.6
240022	6.283	2.0	502.65	80	24	24	22.00 0/-0.27	2	62.83	125.66	8	7	11	7	31.3	440.1	5.7	0.025	2.1
240023	6.283	2.0	1005.31	160	24	24	22.00 0/-0.27	2	62.83	125.66	8	7	11	7	31.3	942.7	5.7	0.036	4.2
240024	6.283	2.0	2010.62	320	24	24	22.00 0/-0.27	2	62.83	125.66	8	7	11	7	31.3	1948.0	5.7	0.058	8
240032	7.854	2.5	502.65	64	24	24	21.50 0/-0.27	2	62.83	125.66	9	7	11	7	31.3	440.1	5.7	0.027	2.0
240033	7.854	2.5	1005.31	128	24	24	21.50 0/-0.27	2	62.83	125.66	9	7	11	7	31.3	942.7	5.7	0.036	4.1
240034	7.854	2.5	2010.62	256	24	24	21.50 0/-0.27	2	62.83	125.66	9	7	11	7	31.3	1948.0	5.7	0.053	8
240042	9.425	3.0	508.94	54	29	29	26.00 0/-0.34	2	63.62	127.23	9	10	15	9	34.4	440.1	7.7	0.029	3.0
240043	9.425	3.0	1017.88	108	29	29	26.00 0/-0.34	2	63.62	127.23	9	10	15	9	34.4	949.1	7.7	0.037	6.0
240044	9.425	3.0	2035.75	216	29	29	26.00 0/-0.34	2	63.62	127.23	9	10	15	9	34.4	1967.0	7.7	0.055	11.5
240052	12.566	4.0	502.65	40	39	39	35.00 0/-0.34	2	62.83	125.66	12	10	15	9	37.5	427.7	7.7	0.030	5.4
240053	12.566	4.0	1005.31	80	39	39	35.00 0/-0.34	2	62.83	125.66	12	10	15	9	37.5	930.3	7.7	0.037	10.8
240054	12.566	4.0	2010.62	160	39	39	35.00 0/-0.34	2	62.83	125.66	12	10	15	9	37.5	1935.6	7.7	0.050	21.0
240062	15.708	5.0	502.65	32	49	49	34.00 0/-0.34	3	62.83	125.66	12	14	20	13	30.2	442.3	11.7	0.028	6.6
240063	15.708	5.0	1005.31	64	49	49	34.00 0/-0.34	3	62.83	125.66	12	14	20	13	30.2	944.9	11.7	0.034	13.1
240064	15.708	5.0	2010.62	128	49	49	34.00 0/-0.34	3	62.83	125.66	12	14	20	13	30.2	1950.2	11.7	0.045	24.7
240072	18.850	6.0	508.94	27	59	59	43.00 0/-0.41	3	63.62	127.23	16	18	26	17	31.4	446.1	15.7	0.031	10.1
240073	18.850	6.0	1017.88	54	59	59	43.00 0/-0.41	3	63.62	127.23	16	18	26	17	31.4	955.0	15.7	0.036	20.3
240074	18.850	6.0	2035.75	108	59	59	43.00 0/-0.41	3	63.62	127.23	16	18	26	17	31.4	1973.0	15.7	0.047	37.5
240082	25.133	8.0	502.65	20	79	79	71.00 0/-0.41	3	62.83	125.66	25	22	33	21	26.7	449.3	19.7	0.029	22.1
240083	25.133	8.0	1005.31	40	79	79	71.00 0/-0.41	3	62.83	125.66	25	22	33	21	26.7	952.0	19.7	0.033	44.3
240084	25.133	8.0	2010.62	80	79	79	71.00 0/-0.41	3	62.83	125.66	25	22	33	21	26.7	1957.3	19.7	0.041	82.5
240092	31.416	10.0	502.65	16	99	99	89.00 0/-0.41	3	62.83	125.66	32	33	48	32	125.2	252.3	19.7	0.029	34.8
240093	31.416	10.0	1005.31	32	99	99	89.00 0/-0.41	3	62.83	125.66	32	33	48	32	125.2	755.0	19.7	0.032	69.5

p (mm): Teilung / graduation / pitch

z : Zähnezahl / nom de dents / number of teeth

d_1 : vorgebohrt / préperçé / predrilled

Gerade verzahnt, Modulteilung Dentures droites, à pas Module Straight tooth, Modular pitch

Gehärtet und geschliffen

Material: 16MnCr5 DIN 1.7131
Zahnung: Eingriffswinkel $\alpha = 20^\circ$
gerade verzahnt
gehärtet (ca. HRC 60)
und ballig geschliffen
Qualität: 6f24 DIN 3962/63/67
f_p (mm): Teilungs-Einzelabweichung
Modul ≤ 3 ; 0.006
Modul > 3 ; 0.008



Trempees et rectifiées

Matière: 16MnCr5 DIN 1.7131
Denture: angle de pression $\alpha = 20^\circ$
denture droite
trempee (ca. HRC 60)
rectifiée et bombée
Qualité: 6f24 DIN 3962/63/67
f_p (mm): Erreur individuelle de pas
Modul ≤ 3 ; 0.006
Modul > 3 ; 0.008

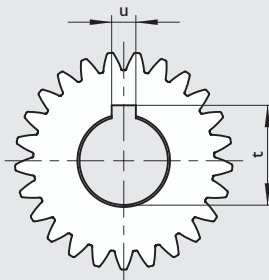

Hardened and ground

Material: 16MnCr5 DIN 1.7131
Teeth: pressure angle $\alpha = 20^\circ$
straight teeth
hardened (ca. HRC 60)
ground, crowned
Quality: 6f24 DIN 3962/63/67
f_p (mm): Adjacent pitch error
Modul ≤ 3 ; 0.006
Modul > 3 ; 0.008

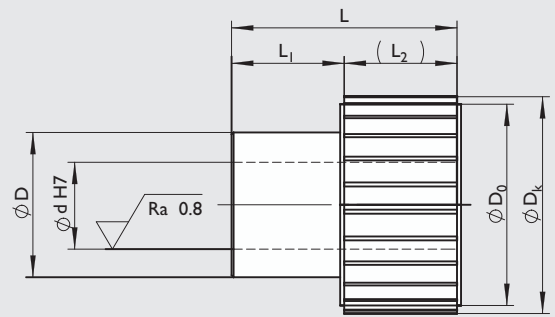

Part No.	P	Modul	z	d ₁	d _k	d ₀	D	L	L ₁	L ₂	t	u	J	m(kg)
I41501	4.712	1.5	25	16	40.5	37.5	30	46	26	20	18.3	5	44	0.24
I41502	4.712	1.5	32	22	51	48	36	48	28	20	24.8	6	109	0.36
I41503	4.712	1.5	40	22	63	60	36	48	28	20	24.8	6	226	0.52
I42001	6.283	2	25	16	54	50	30	54	26	28	18.3	5	147	0.49
I42002	6.283	2	25	22	54	50	36	56	28	28	24.8	6	160	0.49
I42003	6.283	2	28	30	60	56	50	60	32	28	33.3	8	327	0.7
I42004	6.283	2	32	16	68	64	30	54	26	28	18.3	5	373	0.76
I42005	6.283	2	32	22	68	64	36	56	28	28	24.8	6	386	0.76
I42006	6.283	2	32	30	68	64	50	60	32	28	33.3	8	476	0.86
I42007	6.283	2	32	32	68	64	55	65	37	28	35.3	10	567	0.98
I42008	6.283	2	36	40	76	72	62	65	37	28	43.3	12	867	1.12
I42009	6.283	2	40	32	84	80	55	65	37	28	35.3	10	1085	1.38
I42010	6.283	2	40	40	84	80	62	65	37	28	43.3	12	1169	1.33
I42011	6.283	2	40	45	84	80	68	65	37	28	48.8	14	1280	1.34
I42012	6.283	2	50	45	104	100	68	65	37	28	48.8	14	2546	1.96
I42501	7.854	2.5	22	22	60	55	36	56	28	28	24.8	6	222	0.58
I42502	7.854	2.5	28	32	75	70	55	65	37	28	35.3	10	722	1.12
I42503	7.854	2.5	36	40	95	90	62	65	37	28	43.3	12	1698	1.62
I43001	9.425	3	22	22	72	66	36	56	28	28	24.8	6	433	0.8
I43002	9.425	3	22	25	72	66	44	60	32	28	28.3	8	481	0.9
I43003	9.425	3	22	30	72	66	50	60	32	28	33.3	8	523	0.91
I43004	9.425	3	22	32	72	66	55	65	37	28	35.3	10	614	1.03
I43005	9.425	3	22	35	72	66	55	65	37	28	38.3	10	591	0.95
I43006	9.425	3	25	40	81	75	62	65	37	28	43.3	12	970	1.2
I43007	9.425	3	28	22	90	84	36	56	28	28	24.8	6	1093	1.27
I43008	9.425	3	28	25	90	84	44	60	32	28	28.3	8	1141	1.36

p (mm): Teilung / graduation / pitch

z: Zähnezahl / nom de dents / number of teeth

J: (10⁻⁶ kg m²) Inertia

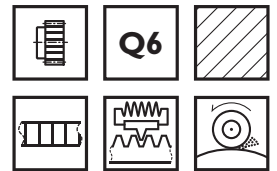

Leistungsdaten

Performance

Performance

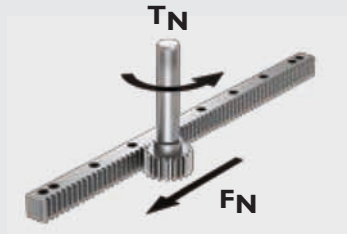

Part No.	Tangentialkraft FN (N)	Moment TN (Nm)	Tangentialkraft FN (N)	Moment TN (Nm)	Tangentialkraft FN (N)	Moment TN (Nm)	Artikel-Nr. Spannsatz	Übertragbares Moment (Nm)
I41501	3732	70	1550	29	829	16	I40001	87
I41502	3403	82	1535	37	1047	25	I40002	258
I41503	3206	96	1470	44	1296	39	I40002	258
I42001	6820	171	2979	75	1314	33	I40001	87
I42002	6820	171	2979	75	1314	33	I40002	258
I42003	6865	192	2993	84	1464	41	409031	686
I42004	6408	205	2950	94	1659	53	I40001	87
I42005	6408	205	2950	94	1659	53	I40002	258
I42006	6408	205	2950	94	1659	53	409031	686
I42007	6408	205	2950	94	1659	53	I40004	567
I42008	6234	224	2852	103	1879	68	I40005	1488
I42009	6083	243	2757	110	2145	86	I40004	567
I42010	6083	243	2757	110	2145	86	I40005	1488
I42011	6083	243	2757	110	2145	86	412031	1388
I42012	5770	289	2524	126	2000	100	412031	1388
I42501	9126	251	4902	135	1752	48	I40002	258
I42502	8895	311	4964	174	2196	77	I40004	567
I42503	8635	389	4749	214	3145	142	I40005	1488
I43001	13152	434	7086	234	2370	78	I40002	258
I43002	13152	434	7086	234	2370	78	I40003	389
I43003	13152	434	7086	234	2370	78	409031	686
I43004	13152	434	7086	234	2370	78	I40004	567
I43005	13152	434	7086	234	2370	78	I40004	746
I43006	13323	500	7168	269	2762	104	I40005	1488
I43007	13416	564	7200	302	3274	138	I40002	258
I43008	13416	564	7200	302	3274	138	I40003	389

Gerade verzahnt, Modulteilung Dentures droites, à pas Module Straight tooth, Modular pitch

Gehärtet und geschliffen

Material: 16MnCr5 DIN 1.7131
Zahnung: Eingriffswinkel $\alpha = 20^\circ$
gerade verzahnt
gehärtet (ca. HRC 60)
und ballig geschliffen
Qualität: 6f24 DIN 3962/63/67
f_p (mm): Teilungs-Einzelabweichung
Modul ≤ 3 ; 0.006
Modul > 3 ; 0.008

Trempees et rectifiées

Matière: 16MnCr5 DIN 1.7131
Denture: angle de pression $\alpha = 20^\circ$
denture droite
trempee (ca. HRC 60)
rectifiée et bombée
Qualité: 6f24 DIN 3962/63/67
f_p (mm): Erreur individuelle de pas
Modul ≤ 3 ; 0.006
Modul > 3 ; 0.008

Hardened and ground

Material: 16MnCr5 DIN 1.7131
Teeth: pressure angle $\alpha = 20^\circ$
straight teeth
hardened (ca. HRC 60)
ground, crowned
Quality: 6f24 DIN 3962/63/67
f_p (mm): Adjacent pitch error
Modul ≤ 3 ; 0.006
Modul > 3 ; 0.008

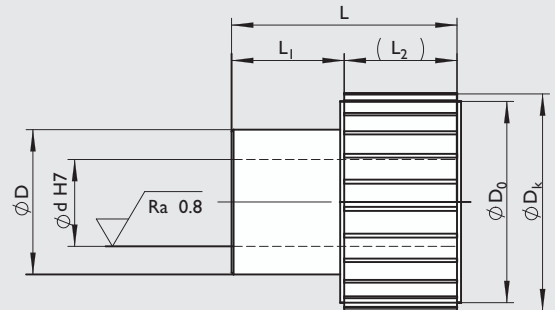
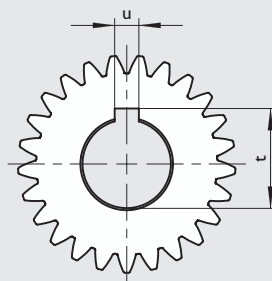

Part No.	P	Modul	z	d _l	d _k	d ₀	D	L	L ₁	L ₂	t	u	J	m(kg)
143009	9.425	3	28	30	90	84	50	60	32	28	33.3	8	1183	1.37
143010	9.425	3	28	32	90	84	55	65	37	28	35.3	10	1275	1.49
143011	9.425	3	28	35	90	84	55	65	37	28	38.3	10	1252	1.41
143012	9.425	3	28	45	90	84	68	65	37	28	48.8	14	1469	1.45
143013	9.425	3	32	40	102	96	62	65	37	28	43.3	12	2112	1.82
143014	9.425	3	36	45	114	108	68	65	37	28	48.8	14	3319	2.24
144001	12.566	4	20	32	88	80	55	75	35	40	35.3	10	1440	1.75
144002	12.566	4	20	35	88	80	55	75	35	40	38.3	10	1414	1.65
144003	12.566	4	20	40	88	80	62	75	35	40	43.3	12	1504	1.66
144004	12.566	4	22	45	96	88	68	75	35	40	48.8	14	2174	1.96
144005	12.566	4	25	32	108	100	55	75	35	40	35.3	10	3248	2.63
144006	12.566	4	25	35	108	100	55	75	35	40	38.3	10	3222	2.54
144007	12.566	4	25	40	108	100	62	75	35	40	43.3	12	3312	2.54
144008	12.566	4	25	55	108	100	80	80	40	40	59.3	16	3757	2.54
144009	12.566	4	28	45	120	112	68	75	35	40	48.8	14	5157	3.13
144010	12.566	4	32	55	136	128	80	80	40	40	59.3	16	8916	4.1
144011	12.566	4	32	75	136	128	110	100	60	40	79.9	20	12526	5.02
144012	12.566	4	40	75	168	160	110	100	60	40	79.9	20	24378	7.27
145001	15.708	5	21	45	115	105	68	85	35	50	48.8	14	4960	3.31
145002	15.708	5	21	55	115	105	80	90	40	50	59.3	16	5278	3.28
145003	15.708	5	25	45	135	125	68	85	35	50	48.8	14	9654	4.72
145004	15.708	5	25	55	135	125	80	90	40	50	59.3	16	9972	4.69
145005	15.708	5	25	75	135	125	110	110	60	50	79.9	20	13409	5.44
146001	18.85	6	21	55	138	126	80	100	40	60	59.3	16	12134	5.55
146002	18.85	6	21	75	138	126	110	120	60	60	79.9	20	15400	6.15
146003	18.85	6	25	55	162	150	80	100	40	60	59.3	16	23814	7.99
146004	18.85	6	25	75	162	150	110	120	60	60	79.9	20	27079	8.58

p (mm): Teilung / graduation / pitch

z: Zähnezahl / nom de dents / number of teeth

J: (10⁻⁶ kg m²) Inertia

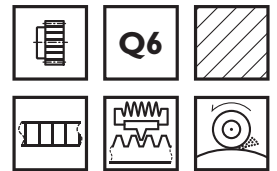

Leistungsdaten

Performance

Performance

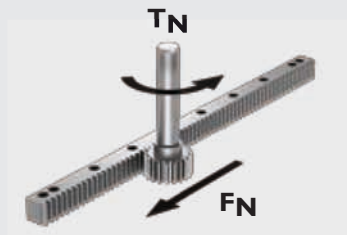

Part No.	Tangentialkraft FN (N)	Moment TN (Nm)	Tangentialkraft FN (N)	Moment TN (Nm)	Tangentialkraft FN (N)	Moment TN (Nm)	Artikel-Nr. Spannsatz	Übertragbares Moment (Nm)
I43009	13416	564	7200	302	3274	138	409031	686
I43010	13416	564	7200	302	3274	138	I40004	567
I43011	13416	564	7200	302	3274	138	I40004	746
I43012	13416	564	7200	302	3274	138	412031	1388
I43013	13363	641	7132	342	3959	190	I40005	1488
I43014	12816	692	6891	372	4629	250	412031	1388
I44001	24068	963	14639	586	4519	181	I40004	567
I44002	24068	963	14639	586	4519	181	I40004	746
I44003	24068	963	14639	586	4519	181	I40005	1488
I44004	4575	1081	14750	649	5175	228	412031	1388
I44005	25140	1257	14780	739	6167	308	I40004	567
I44006	25140	1257	14780	739	6167	308	I40004	746
I44007	25140	1257	14780	739	6167	308	I40005	1488
I44008	25140	1257	14780	739	6167	308	I40006	2434
I44009	25487	1427	14640	820	7137	400	412031	1388
I44010	25117	1608	14459	925	8449	541	I40006	2434
I44011	25117	1608	14459	925	8449	541	I40007	7152
I44012	23556	1885	13490	1079	9618	770	I40007	7152
I45001	37715	1980	26352	1384	8111	426	412031	1388
I45002	37715	1980	26352	1384	8111	426	I40006	2434
I45003	38924	2433	25215	1576	10193	637	412031	1388
I45004	38924	2433	25215	1576	10193	637	I40006	2434
I45005	38924	2433	25215	1576	10193	637	I40007	7152
I46001	53453	3368	41487	2614	12618	795	I40006	2434
I46002	53453	3368	41487	2614	12618	795	I40007	7152
I46003	55128	4135	40194	3015	15664	1175	I40006	2434
I46004	55128	4135	40194	3015	15664	1175	I40007	7152

Gerade verzahnt, Modulteilung

Dentures droites, à pas Module

Straight tooth, Modular pitch

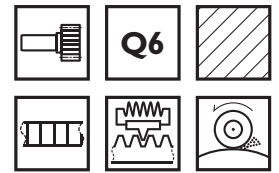

Gehärtet und geschliffen

Material: 16MnCr5 DIN 1.7131
Zahnung: Eingriffswinkel $\alpha = 20^\circ$
 gerade verzahnt
 gehärtet (ca. HRC 60)
 und ballig geschliffen
Qualität: 6f24 DIN 3962/63/67
f_p (mm): Teilungs-Einzelabweichung
 Modul ≤ 3 ; 0.006
 Modul > 3 ; 0.008

Trempees et rectifiées

Matière: 16MnCr5 DIN 1.7131
Denture: angle de pression $\alpha = 20^\circ$
 denture droite
 trempée (ca. HRC 60)
 rectifiée et bombée
Qualité: 6f24 DIN 3962/63/67
f_p (mm): Erreur individuelle de pas
 Modul ≤ 3 ; 0.006
 Modul > 3 ; 0.008

Hardened and ground

Material: 16MnCr5 DIN 1.7131
Teeth: pressure angle $\alpha = 20^\circ$
 straight teeth
 hardened (ca. HRC 60)
 ground, crowned
Quality: 6f24 DIN 3962/63/67
f_p (mm): Adjacent pitch error
 Modul ≤ 3 ; 0.006
 Modul > 3 ; 0.008

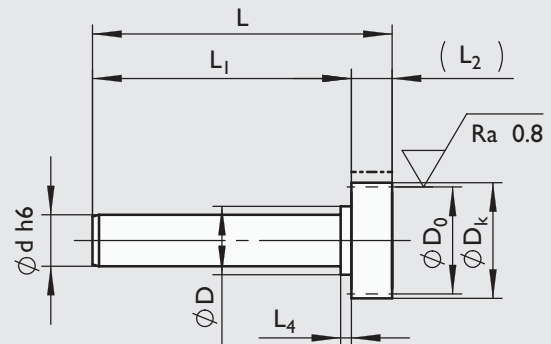

Part No.	p	Modul	z	d	D _k	D ₀	D	L	L ₁	L ₂	L ₄	J	m(kg)	
201020	AE 030	3.142	1.0	20	12	22.0	20.0	16	70	55	15	2.5	3	0.09
201025	AE 030	3.142	1.0	25	12	27.0	25.0	16	70	60.5	9.5	2.5	4	0.09
201116	AE 030	4.712	1.5	16	12	27.9	24.9	16	90	70	20	4.5	7	0.14
201120	AE 045	4.712	1.5	20	20	33.0	30.0	26	110	90	20	4.5	24	0.34
201216	AE 045	6.283	2.0	16	20	37.2	33.2	26	110	90	20	8.0	31	0.37
201220	AE 060	6.283	2.0	20	25	44.0	40.0	32	140	120	20	8.0	79	0.68
201320	AE 060	7.854	2.5	20	25	55.0	50.0	32	145	120	25	8.0	160	0.86
201416	AE 060	9.425	3.0	16	25	55.8	49.8	32	150	120	30	8.0	181	0.93
201420	AE 090	9.425	3.0	20	40	66.0	60.0	50	190	160	30	12.5	647	2.30
201520	AE 090	12.566	4.0	20	40	88.0	80.0	50	200	160	40	18.0	1619	3.24
201620	AE 120	15.708	5.0	20	60	110.0	100.0	85	310	260	50	35.0	7461	9.57
201720	AE 120	18.850	6.0	20	60	132.0	120.0	85	320	260	60	35.0	13159	11.80
201820	AE 120	25.133	8.0	20	60	176.0	160.0	85	340	260	80	35.0	43780	19.06
201821	AE 180	25.133	8.0	20	90	176.0	160.0	105	385	305	80	35.0z	56971	28.31
201916	AE 180	31.416	10.0	16	90	186.0	166.0	105	410	310	100	40.0	67473	31.78

p (mm): Teilung / graduation / pitch

z: Zähnezahl / nom de dents / number of teeth

J: (10⁻⁶ kg m²) Inertia

Gerade verzahnt, Modulteilung

Dentures droites, à pas Module

Straight tooth, Modular pitch

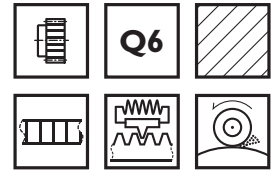

Gehärtet und geschliffen

Material: 16MnCr5 DIN 1.7131
Zahnung: Eingriffswinkel $\alpha = 20^\circ$
 gerade verzahnt
 gehärtet (ca. HRC 60)
 und ballig geschliffen
Qualität: 6f24 DIN 3962/63/67
f_p (mm): Teilungs-Einzelabweichung
 Modul ≤ 3 ; 0.006
 Modul > 3 ; 0.008

Trempees et rectifiées

Matière: 16MnCr5 DIN 1.7131
Denture: angle de pression $\alpha = 20^\circ$
 denture droite
 trempée (ca. HRC 60)
 rectifiée et bombée
Qualité: 6f24 DIN 3962/63/67
f_p (mm): Erreur individuelle de pas
 Modul ≤ 3 ; 0.006
 Modul > 3 ; 0.008

Hardened and ground

Material: 16MnCr5 DIN 1.7131
Teeth: pressure angle $\alpha = 20^\circ$
 straight teeth
 hardened (ca. HRC 60)
 ground, crowned
Quality: 6f24 DIN 3962/63/67
f_p (mm): Adjacent pitch error
 Modul ≤ 3 ; 0.006
 Modul > 3 ; 0.008

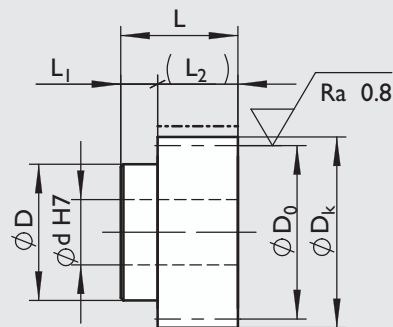

Part No.	p	Modul	z	d	Dk	D0	D	L	L1	L2	J	m(kg)
254012	4.712	1.5	20	10	33.0	30.0	25.0	28.0	8.0	20	15	0.12
254022	6.283	2.0	20	15	44.0	40.0	34.5	30.0	10.0	20	50	0.23
254032	7.854	2.5	20	15	55.0	50.0	40.0	37.0	12.0	25	142	0.45
254042	9.425	3.0	20	15	66.0	60.0	40.0	44.0	14.0	30	323	0.74
254052	12.566	4.0	20	30	88.0	80.0	65.0	59.0	19.0	40	1447	1.62
254062	15.708	5.0	20	40	110.0	100.0	85.0	70.0	20.0	50	4293	2.88
254072	18.850	6.0	20	50	132.0	120.0	104.0	100.0	40.0	60	12772	6.46
254082	25.133	8.0	20	50	176.0	160.0	120.0	130.0	50.0	80	47465	15.0
254092	31.416	10.0	20	50	220.0	200.0	150.0	150.0	50.0	100	141188	29.10

p (mm): Teilung / graduation / pitch

z: Zähnezahl / nom de dents / number of teeth

J: (10^{-6} kg m²) Inertia

Schräg verzahnt, Modulteilung Dentures oblique, à pas Module Helical tooth, Modular pitch

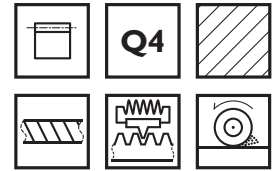

Gehärtet und geschliffen

Material: C45E DIN 1.1191
Profil: allseitig geschliffen
Zahnung: Eingriffswinkel $\alpha = 20^\circ$
 schrägverzahnt rechts,
 Schrägungswinkel $19^\circ 31'42''$
 gehärtet (ca. HRC 56)
 und geschliffen
Qualität: 4h21 DIN 3962/63/67
 f_p (mm): Teilungs-Einzelabweichung
 Modul ≤ 3 ; 0.003
 Modul > 3 ; 0.005
 p_f (mm): Toleranz der teilungsgenauen
 Ablängung -0.05/-0.2
 F_{pL} (mm): bezogen auf Länge L
 F_{p250} bezogen auf Länge 250mm
 Teilungs-Gesamtabweichung



Trempées et rectifiées

Matière: C45E DIN 1.1191
Profil: réctifiée toutes les faces
Denture: angle de pression $\alpha = 20^\circ$
 à dentures oblique droite,
 angle d'hélice $19^\circ 31'42''$
 trempée (ca. HRC 56)
 et rectifiée
Qualité: 4h21 DIN 3962/63/67
 f_p (mm): Erreur individuelle de pas
 Modul ≤ 3 ; 0.003
 Modul > 3 ; 0.005
 p_f (mm): Tolérance de coupe par rapport
 au pas -0.05/-0.2
 F_{pL} (mm): basée sur la longueur L
 F_{p250} basée sur la longueur 250mm
 Erreur totale de pas

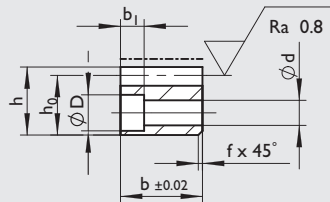

Hardened and ground

Material: C45E DIN 1.1191
Profil: all faces ground
Teeth: pressure angle $\alpha = 20^\circ$
 helical tooth system right,
 helix angle $19^\circ 31'42''$
 hardened (ca. HRC 56)
 and ground
Quality: 4h21 DIN 3962/63/67
 f_p (mm): Adjacent pitch error
 Modul ≤ 3 ; 0.003
 Modul > 3 ; 0.005
 p_f (mm): Tolerance of cut for continuous
 mounting -0.05/-0.2
 F_{pL} (mm): based on length L
 F_{p250} based on length 250mm
 Cumulative pitch error

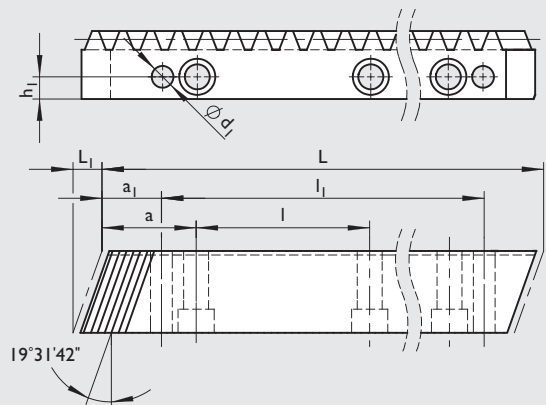

Part-No.	pt	Modul	L	L ₁	z	b	h	h ₀	f ^{+0.5}	a	l	h ₁	d	D	b ₁	a ₁	l ₁	d ₁	F _{pL}	F _{p250}	m(kg)	
246012-Q4	5	1.5	500	6.7	100	19	19	17.5	0/-0.011	2	62.5	125	8	7	11	7	31.7	436.6	5.7	0.016	0.012	1.3
246013-Q4	5	1.5	1000	6.7	200	19	19	17.5	0/-0.011	2	62.5	125	8	7	11	7	31.7	936.6	5.7	0.025	0.012	2.6
246022-Q4	6.667	2	500	8.5	75	24	24	22.0	0/-0.011	2	62.5	125	8	7	11	7	31.7	436.6	5.7	0.014	0.011	2.1
246023-Q4	6.667	2	1000	8.5	150	24	24	22.0	0/-0.011	2	62.5	125	8	7	11	7	31.7	936.6	5.7	0.021	0.011	4.1
246032-Q4	8.333	2.5	500	8.5	60	24	24	21.5	0/-0.011	2	62.5	125	9	7	11	7	31.7	436.6	5.7	0.014	0.011	2.0
246033-Q4	8.333	2.5	1000	8.5	120	24	24	21.5	0/-0.011	2	62.5	125	9	7	11	7	31.7	936.6	5.7	0.018	0.011	4.1
246042-Q4	10.000	3	500	10.3	50	29	29	26.0	0/-0.014	2	62.5	125	9	10	15	9	35	430	7.7	0.015	0.013	3.0
246043-Q4	10.000	3	1000	10.3	100	29	29	26.0	0/-0.014	2	62.5	125	9	10	15	9	35	930	7.7	0.018	0.013	5.9
246052-Q4	13.333	4	506.67	13.8	38	39	39	35.0	0/-0.014	3	62.5	125	12	10	15	9	33.3	433	7.7	0.016	0.015	5.4
246053-Q4	13.333	4	1000	13.8	75	39	39	35.0	0/-0.014	3	62.5	125	12	10	15	9	33.3	933.4	7.7	0.019	0.015	10.7
246062-Q4	16.667	5	500	17.4	30	49	49	34.0	0/-0.014	3	62.5	125	12	14	20	13	37.5	425	11.7	0.015	0.014	6.5
246063-Q4	16.667	5	1000	17.4	60	49	49	34.0	0/-0.014	3	62.5	125	12	14	20	13	37.5	925	11.7	0.018	0.014	13.1
246072-Q4	20.000	6	500	20.9	25	59	59	43.0	0/-0.016	3	62.5	125	16	18	26	17	37.5	425	15.7	0.015	0.014	10.0
246073-Q4	20.000	6	1000	20.9	50	59	59	43.0	0/-0.016	3	62.5	125	16	18	26	17	37.5	925	15.7	0.018	0.014	19.9
246082-Q4	26.667	8	480	28	18	79	79	71.0	0/-0.016	3	60	120	25	22	33	21	120	240	19.7	0.017	0.016	22.0
246083-Q4	26.667	8	960	28	36	79	79	71.0	0/-0.016	3	60	120	25	22	33	21	120	720	19.7	0.019	0.016	44.0
246092-Q4	33.333	10	500	35.1	15	99	99	89.0	0/-0.016	3	62.5	125	32	33	48	32	125	250	19.7	0.016	0.016	34.0
246093-Q4	33.333	10	1000	35.1	30	99	99	89.0	0/-0.016	3	62.5	125	32	33	48	32	125	750	19.7	0.018	0.016	68.0

p (mm): Teilung / graduation / pitch

z: Zähnezahl / nom de dents / number of teeth

d₁: vorgebohrt / préperçé / predrilled

Schräg verzahnt, Modulteilung

Dentures oblique, à pas Module

Helical tooth, Modular pitch



Gehärtet und geschliffen

Material: C45E DIN 1.1191
Profil: allseitig geschliffen
Zahnung: Eingriffswinkel $\alpha = 20^\circ$
 schrägverzahnt rechts
 Schrägungswinkel $19^\circ 31'42''$
 gehärtet (ca. HRC 56)
 und geschliffen
Qualität: 5h22 DIN 3962/63/67
 f_p (mm): Teilungs-Einzelabweichung
 Modul ≤ 3 ; 0.004
 Modul > 3 ; 0.006
 p_f (mm): Toleranz der teilungsgenauen
 Ablängung -0.05/-0.2
 F_{pL} (mm): bezogen auf Länge L
 F_{p250} bezogen auf Länge 250mm
 Teilungs-Gesamtabweichung

Trempées et rectifiées

Matière: C45E DIN 1.1191
Profil: réctifiée toutes les faces
Denture: angle de pression $\alpha = 20^\circ$
 à dentures oblique droite
 angle d'hélice $19^\circ 31'42''$
 trempée (ca. HRC 56)
 et rectifiée
Qualité: 5h22 DIN 3962/63/67
 f_p (mm): Erreur individuelle de pas
 Modul ≤ 3 ; 0.004
 Modul > 3 ; 0.006
 p_f (mm): Tolérance de coupe par rapport
 au pas -0.05/-0.2
 F_{pL} (mm): basée sur la longueur L
 F_{p250} basée sur la longueur 250mm
 Erreur totale de pas

Hardened and ground

Material: C45E DIN 1.1191
Profil: all faces ground
Teeth: pressure angle $\alpha = 20^\circ$
 helical tooth system right
 helix angle $19^\circ 31'42''$
 hardened (ca. HRC 56)
 and ground
Quality: 5h22 DIN 3962/63/67
 f_p (mm): Adjacent pitch error
 Modul ≤ 3 ; 0.004
 Modul > 3 ; 0.006
 p_f (mm): Tolerance of cut for continuous
 mounting -0.05/-0.2
 F_{pL} (mm): based on length L
 F_{p250} based on length 250mm
 Cumulative pitch error

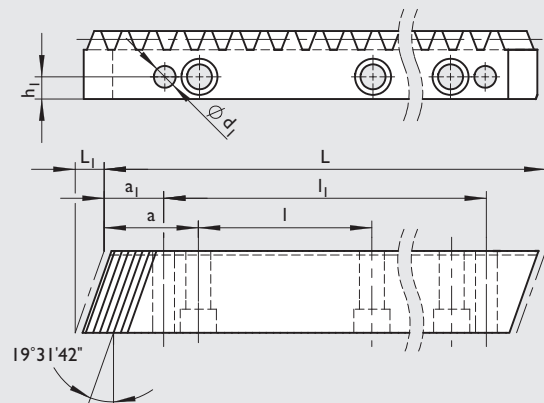
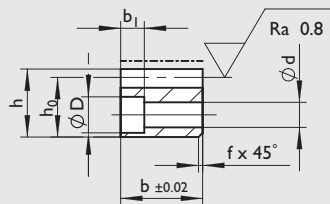

Part-No.	pt	Modul	L	L _l	z	b	h	h ₀	f ^{+0.5}	a	l	h _l	d	D	b _l	a _l	l _l	d ₁	F _{pL}	F _{p250}	m(kg)	
246012-Q5	5	1.5	500	6.7	100	19	19	17.5	0/-0.016	2	62.5	125	8	7	11	7	31.7	436.6	5.7	0.021	0.016	1.3
246013-Q5	5	1.5	1000	6.7	200	19	19	17.5	0/-0.016	2	62.5	125	8	7	11	7	31.7	936.6	5.7	0.030	0.016	2.6
246022-Q5	6.667	2	500	8.5	75	24	24	22.0	0/-0.016	2	62.5	125	8	7	11	7	31.7	436.6	5.7	0.018	0.014	2.1
246023-Q5	6.667	2	1000	8.5	150	24	24	22.0	0/-0.016	2	62.5	125	8	7	11	7	31.7	936.6	5.7	0.025	0.014	4.1
246032-Q5	8.333	2.5	500	8.5	60	24	24	21.5	0/-0.016	2	62.5	125	9	7	11	7	31.7	436.6	5.7	0.019	0.016	2.0
246033-Q5	8.333	2.5	1000	8.5	120	24	24	21.5	0/-0.016	2	62.5	125	9	7	11	7	31.7	936.6	5.7	0.024	0.016	4.1
246042-Q5	10.000	3	500	10.3	50	29	29	26.0	0/-0.022	2	62.5	125	9	10	15	9	35	430	7.7	0.020	0.017	3.0
246043-Q5	10.000	3	1000	10.3	100	29	29	26.0	0/-0.022	2	62.5	125	9	10	15	9	35	930	7.7	0.026	0.017	5.9
246052-Q5	13.333	4	506.67	13.8	38	39	39	35.0	0/-0.022	3	62.5	125	12	10	15	9	33.3	433	7.7	0.021	0.019	5.4
246053-Q5	13.333	4	1000	13.8	75	39	39	35.0	0/-0.022	3	62.5	125	12	10	15	9	33.3	933.4	7.7	0.026	0.019	10.7
246062-Q5	16.667	5	500	17.4	30	49	39	34.0	0/-0.022	3	62.5	125	12	14	20	13	37.5	425	11.7	0.020	0.018	6.5
246063-Q5	16.667	5	1000	17.4	60	49	39	34.0	0/-0.022	3	62.5	125	12	14	20	13	37.5	925	11.7	0.024	0.018	13.1
246072-Q5	20.000	6	500	20.9	25	59	49	43.0	0/-0.027	3	62.5	125	16	18	26	17	37.5	425	15.7	0.022	0.020	10.0
246073-Q5	20.000	6	1000	20.9	50	59	49	43.0	0/-0.027	3	62.5	125	16	18	26	17	37.5	925	15.7	0.026	0.020	19.9
246082-Q5	26.667	8	480	28	18	79	79	71.0	0/-0.027	3	60	120	25	22	33	21	120	240	19.7	0.021	0.020	22.0
246083-Q5	26.667	8	960	28	36	79	79	71.0	0/-0.027	3	60	120	25	22	33	21	120	720	19.7	0.024	0.020	44.0
246092-Q5	33.333	10	500	35.1	15	99	99	89.0	0/-0.027	3	62.5	125	32	33	48	32	125	250	19.7	0.020	0.019	34.0
246093-Q5	33.333	10	1000	35.1	30	99	99	89.0	0/-0.027	3	62.5	125	32	33	48	32	125	750	19.7	0.023	0.019	68.0

p (mm): Teilung / graduation / pitch

z: Zähnezahl / nom de dents / number of teeth

d₁: vorgebohrt / préperçé / predrilled

Schräg verzahnt, Modulteilung

Dentures oblique, à pas Module

Helical tooth, Modular pitch

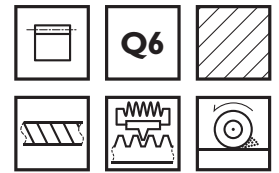

Gehärtet und geschliffen

Material: C45E DIN 1.1191
Profil: allseitig geschliffen
Zahnung: Eingriffswinkel $\alpha = 20^\circ$
 schrägverzahnt rechts
 Schrägungswinkel $19^\circ 31'42''$
 gehärtet (ca. HRC 56)
 und geschliffen
Qualität: 6h23 DIN 3962/63/67
 f_p (mm): Teilungs-Einzelabweichung
 Modul ≤ 3 ; 0.006
 Modul > 3 ; 0.008
 p_f (mm): Toleranz der teilungsgenauen
 Ablängung -0.05/-0.2

Trempeés et rectifiées

Matière: C45E DIN 1.1191
Profil: réctifiée toutes les faces
Denture: angle de pression $\alpha = 20^\circ$
 à dentures oblique droite
 angle d'hélice $19^\circ 31'42''$
 trempée (ca. HRC 56)
 et rectifiée
Qualité: 6h23 DIN 3962/63/67
 f_p (mm): Erreur individuelle de pas
 Modul ≤ 3 ; 0.006
 Modul > 3 ; 0.008
 p_f (mm): Tolérance de coupe par rapport
 au pas -0.05/-0.2

Hardened and ground

Material: C45E DIN 1.1191
Profil: all faces ground
Teeth: pressure angle $\alpha = 20^\circ$
 helical tooth system right
 helix angle $19^\circ 31'42''$
 hardened (ca. HRC 56)
 and ground
Quality: 6h23 DIN 3962/63/67
 f_p (mm): Adjacent pitch error
 Modul ≤ 3 ; 0.006
 Modul > 3 ; 0.008
 p_f (mm): Tolerance of cut for continuous
 mounting -0.05/-0.2

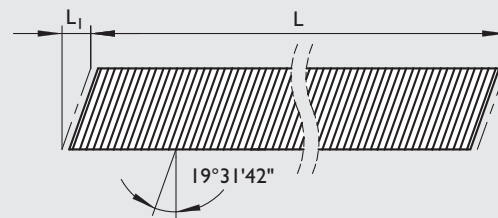
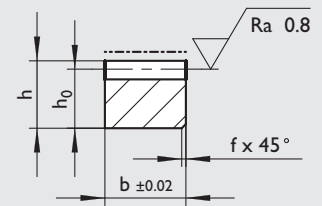
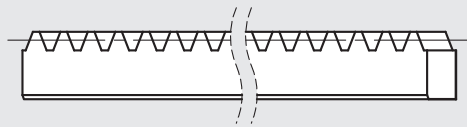
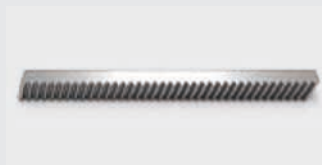

Option: 1.7131 (16MnCr5)

Part No.	P_n	P_t	Modul	L	L_1	z	b	h	h_0	$f^{+0.5}$	F_p	m(kg)
244612	4.712	5.00	1.5	500.00	6.7	100	19	19	17.50	2	0.029	1.3
244613	4.712	5.00	1.5	1000.00	6.7	200	19	19	17.50	2	0.043	2.6
244622	6.283	6.67	2.0	500.00	8.5	75	24	24	22.00	2	0.025	2.1
244623	6.283	6.67	2.0	1000.00	8.5	150	24	24	22.00	2	0.036	4.1
244632	7.854	8.33	2.5	500.00	8.5	60	24	24	21.50	2	0.027	2.0
244633	7.854	8.33	2.5	1000.00	8.5	120	24	24	21.50	2	0.036	4.1
244642	9.425	10.00	3.0	500.00	10.3	50	29	29	26.00	2	0.028	3.0
244643	9.425	10.00	3.0	1000.00	10.3	100	29	29	26.00	2	0.037	5.9
244652	12.566	13.33	4.0	506.67	13.8	38	39	39	35.00	3	0.030	5.4
244653	12.566	13.33	4.0	1000.00	13.8	75	39	39	35.00	3	0.036	10.7
244662	15.708	16.67	5.0	500.00	17.4	30	49	39	34.00	3	0.028	6.5
244663	15.708	16.67	5.0	1000.00	17.4	60	49	39	34.00	3	0.034	13.1
244672	18.850	20.00	6.0	500.00	20.9	25	59	49	43.00	3	0.031	10.0
244673	18.850	20.00	6.0	1000.00	20.9	50	59	49	43.00	3	0.036	19.9
244682	25.133	26.66	8.0	480.00	28.0	18	79	79	71.00	3	0.029	22.0
244683	25.133	26.66	8.0	960.00	28.0	36	79	79	71.00	3	0.033	44.0
244692	31.416	33.33	10.0	500.00	35.1	15	99	99	89.00	3	0.029	34.5
244693	31.416	33.33	10.0	1000.00	35.1	30	99	99	89.00	3	0.032	69.0

P_n (mm): Normalteilung, pas réel, normal pitch

P_t (mm): Stirnteilung, pas apparent, transverse

z: Zähnezahl / Nom de dents / Number of teeth

Schräg verzahnt, Modulteilung

Dentures oblique, à pas Module

Helical tooth, Modular pitch

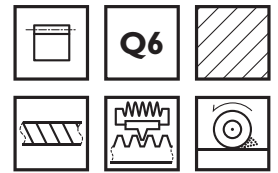

Gehärtet und geschliffen

Material: C45E DIN 1.1191
Profil: allseitig geschliffen
Zahnung: Eingriffswinkel $\alpha = 20^\circ$
 schrägverzahnt rechts,
 Schrägungswinkel $19^\circ 31'42''$
 gehärtet (ca. HRC 56)
 und geschliffen
Qualität: 6h23 DIN 3962/63/67
 f_p (mm): Teilungs-Einzelabweichung
 Modul ≤ 3 ; 0.006
 Modul > 3 ; 0.008
 p_f (mm): Toleranz der teilungsgenauen
 Ablängung -0.05/-0.2
 F_{pL} (mm): bezogen auf Länge L
 Teilungs-Gesamtabweichung

trempeées et rectifiées

Matière: C45E DIN 1.1191
Profil: réctifiée toutes les faces
Denture: angle de pression $\alpha = 20^\circ$
 à dentures oblique droite,
 angle d'hélice $19^\circ 31'42''$
 trempée (ca. HRC 56)
 et rectifiée
Qualité: 6h23 DIN 3962/63/67
 f_p (mm): Erreur individuelle de pas
 Modul ≤ 3 ; 0.006
 Modul > 3 ; 0.008
 p_f (mm): Tolérance de coupe par rapport
 au pas -0.05/-0.2
 F_{pL} (mm): basée sur la longueur L
 Erreur totale de pas

hardened and ground

Material: C45E DIN 1.1191
Profil: all faces ground
Teeth: pressure angle $\alpha = 20^\circ$
 helical tooth system right,
 helix angle $19^\circ 31'42''$
 hardened (ca. HRC 56)
 and ground
Quality: 6h23 DIN 3962/63/67
 f_p (mm): Adjacent pitch error
 Modul ≤ 3 ; 0.006
 Modul > 3 ; 0.008
 p_f (mm): Tolerance of cut for continuous
 mounting -0.05/-0.2
 F_{pL} (mm): based on length L
 Cumulative pitch error

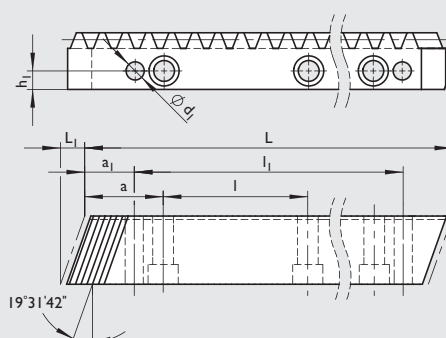
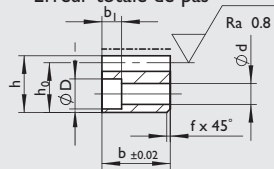

Option: 1.7131 (16MnCr5)

Part No.	pt	Modul	L	L ₁	z	b	h	h ₀	f ^{+0.5}	a	l	h ₁	d	D	b ₀	a ₁	l ₁	d ₁	F ₀	m(kg)	
246012	5.00	1.5	500.00	6.7	100	19	19	17.50	0/-027	2	62.5	125.00	8	7	11	7	31.7	436.6	5.7	0.029	1.3
246013	5.00	1.5	1000.00	6.7	200	19	19	17.50	0/-027	2	62.5	125.00	8	7	11	7	31.7	936.6	5.7	0.043	2.6
246022	6.67	2.0	500.00	8.5	75	24	24	22.00	0/-027	2	62.5	125.00	8	7	11	7	31.7	436.6	5.7	0.025	2.1
246023	6.67	2.0	1000.00	8.5	150	24	24	22.00	0/-027	2	62.5	125.00	8	7	11	7	31.7	936.6	5.7	0.036	4.1
246024	6.66	2.0	2000.00	8.5	300	24	24	22.00	0/-027	2	62.5	125.00	8	7	11	7	31.7	1936.6	5.7	0.058	8.2
246032	8.33	2.5	500.00	8.5	60	24	24	21.50	0/-027	2	62.5	125.00	9	7	11	7	31.7	436.6	5.7	0.027	2.0
246033	8.33	2.5	1000.00	8.5	120	24	24	21.50	0/-027	2	62.5	125.00	9	7	11	7	31.7	936.6	5.7	0.036	4.1
246034	8.33	2.5	2000.00	8.5	240	24	24	21.50	0/-027	2	62.5	125.00	9	7	11	7	31.7	1936.6	5.7	0.053	8.2
246042	10.00	3.0	500.00	10.3	50	29	29	26.00	0/-034	2	62.5	125.00	9	10	15	9	35.0	430.0	7.7	0.028	3.0
246043	10.00	3.0	1000.00	10.3	100	29	29	26.00	0/-034	2	62.5	125.00	9	10	15	9	35.0	930.0	7.7	0.037	5.9
246044	10.00	3.0	2000.00	10.3	200	29	29	26.00	0/-034	2	62.5	125.00	9	10	15	9	35.0	1930.0	7.7	0.054	11.2
246052	13.33	4.0	506.67	13.8	38	39	39	35.00	0/-034	3	62.5	125.00	12	10	15	9	33.3	433.0	7.7	0.030	5.4
246053	13.33	4.0	1000.00	13.8	75	39	39	35.00	0/-034	3	62.5	125.00	12	10	15	9	33.3	933.4	7.7	0.036	10.7
246054	13.33	4.0	2000.00	13.8	150	39	39	35.00	0/-034	3	62.5	125.00	12	10	15	9	33.3	1933.4	7.7	0.050	20.5
246062	16.67	5.0	500.00	17.4	30	49	39	34.00	0/-034	3	62.5	125.00	12	14	20	13	37.5	425.0	11.7	0.028	6.5
246063	16.67	5.0	1000.00	17.4	60	49	39	34.00	0/-034	3	62.5	125.00	12	14	20	13	37.5	925.0	11.7	0.034	13.1
246064	16.66	5.0	2000.00	17.4	120	49	39	34.00	0/-034	3	62.5	125.00	12	14	20	13	37.5	1925.0	11.7	0.045	24.5
246072	20.00	6.0	500.00	20.9	25	59	49	43.00	0/-041	3	62.5	125.00	16	18	26	17	37.5	425.0	15.7	0.031	10.0
246073	20.00	6.0	1000.00	20.9	50	59	49	43.00	0/-041	3	62.5	125.00	16	18	26	17	37.5	925.0	15.7	0.036	19.9
246074	20.00	6.0	2000.00	20.9	100	59	49	43.00	0/-041	3	62.5	125.00	16	18	26	17	37.5	1925.0	15.7	0.046	36.5
246082	26.66	8.0	480.00	28.0	18	79	79	71.00	0/-041	3	60.0	120.00	25	22	33	21	120.0	240.0	19.7	0.029	22.0
246083	26.66	8.0	960.00	28.0	36	79	79	71.00	0/-041	3	60.0	120.00	25	22	33	21	120.0	720.0	19.7	0.033	44.0
246084	26.66	8.0	1920.00	28.0	72	79	79	71.00	0/-041	3	60.0	120.00	25	22	33	21	120.0	1680.0	19.7	0.040	78.0
246092	33.33	10.0	500.00	35.1	15	99	99	89.00	0/-041	3	62.5	125.00	32	33	48	32	125.0	250	19.7	0.029	34.0
246093	33.33	10.0	1000.00	35.1	30	99	99	89.00	0/-041	3	62.5	125.00	32	33	48	32	125.0	750	19.7	0.032	68.0

p (mm): Teilung / graduation / pitch

z: Zähnezahl / nom de dents / number of teeth

d₁: vorgebohrt / préperçé / predrilled

Schräg verzahnt, Modulteilung

Dentures oblique, à pas Module

Helical tooth, Modular pitch

Gehärtet und geschliffen

Material: 16MnCr5 DIN 1.7131
Zahnung: Eingriffswinkel $\alpha = 20^\circ$
 schrägverzahnt
 Schrägungswinkel $\beta = 19^\circ 31'41''$
 gehärtet (ca. HRC 60)
 und ballig geschliffen
Qualität: 6f24 DIN 3962/63/67
f_p (mm): Teilungs-Einzelabweichung
 Modul ≤ 3 ; 0.006
 Modul > 3 ; 0.008

Trempées et réctifiées

Matière: 16MnCr5 DIN 1.7131
Denture: angle de pression $\alpha = 20^\circ$
 à denture oblique
 angle d'hélice $\beta = 19^\circ 31'41''$
 trempée (ca. HRC 60)
 rectifiée et bombée
Qualité: 6f24 DIN 3962/63/67
f_p (mm): Erreur individuelle de pas
 Modul ≤ 3 ; 0.006
 Modul > 3 ; 0.008

Hardened and ground

Material: 16MnCr5 DIN 1.7131
Teeth: pressure angle $\alpha = 20^\circ$
 helical tooth system
 helix angle $\beta = 19^\circ 31'41''$
 hardened (ca. HRC 60)
 ground, crowned
Quality: 6f24 DIN 3962/63/67
f_p (mm): Adjacent pitch error
 Modul ≤ 3 ; 0.006
 Modul > 3 ; 0.008

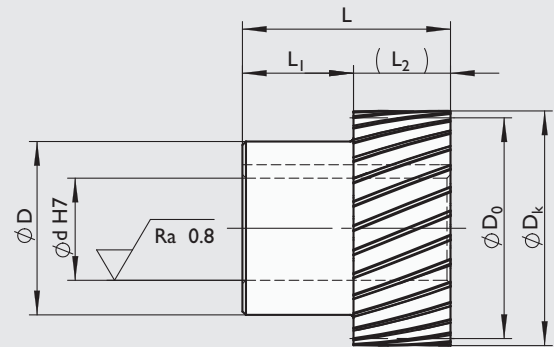
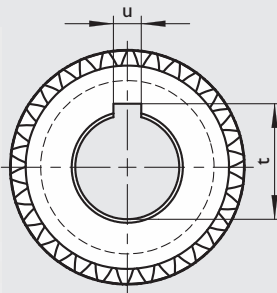

Part No.	P _n	P _t	Modul	z	d _l	d _k	d ₀	D	L	L ₁	L ₂	t	u	J	m(kg)
141551	4.712	5	1.5	21	16	36.42	33.423	30	46	26	20	18.3	5	33	0.21
141552	4.712	5	1.5	30	22	50.75	47.747	36	48	28	20	24.8	6	107	0.36
141553	4.712	5	1.5	39	22	65.07	62.071	36	48	28	20	24.8	6	255	0.55
142051	6.283	6.667	2	21	22	48.56	44.563	36	56	28	28	24.8	6	111	0.40
142052	6.283	6.667	2	30	22	67.66	63.662	36	56	28	28	24.8	6	378	0.75
142053	6.283	6.667	2	30	30	67.66	63.662	50	60	32	28	33.3	8	468	0.85
142054	6.283	6.667	2	30	32	67.66	63.662	55	65	37	28	35.3	10	559	0.97
142055	6.283	6.667	2	39	32	86.76	82.761	55	65w	37	28	35.3	10	1213	1.45
142551	7.854	8.333	2.5	20	22	58.05	53.052	36	56	28	28	24.8	6	196	0.54
142552	7.854	8.333	2.5	25	22	71.31	66.315	36	56	28	28	24.8	6	441	0.81
142553	7.854	8.333	2.5	25	32	71.31	66.315	55	65	37	28	35.3	10	622	1.03
143051	9.425	10	3	20	22	69.66	63.662	36	56	28	28	24.8	6	378	0.75
143052	9.425	10	3	20	25	69.66	63.662	44	60	32	28	28.3	8	426	0.84
143053	9.425	10	3	20	30	69.66	63.662	50	60	32	28	33.3	8	468	0.85
143054	9.425	10	3	20	32	69.66	63.662	55	65	37	28	35.3	10	559	0.97
143055	9.425	10	3	25	22	85.58	79.578	36	56	28	28	24.8	6	886	1.14
143056	9.425	10	3	25	25	85.58	79.578	44	60	32	28	28.3	8	934	1.24
143057	9.425	10	3	25	30	85.58	79.578	50	60	32	28	33.3	8	976	1.25
143058	9.425	10	3	25	32	85.58	79.578	55	65	37	28	35.3	10	1067	1.36
143059	9.425	10	3	25	35	85.58	79.578	55	65	37	28	38.3	10	1044	1.28

p (mm): Teilung / graduation / pitch

z: Zähnezahl / nom de dents / number of teeth

J: (10⁻⁶ kg m²) Inertia

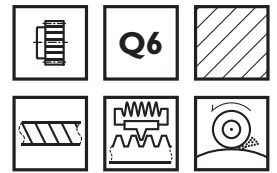

Leistungsdaten

Performance

Performance

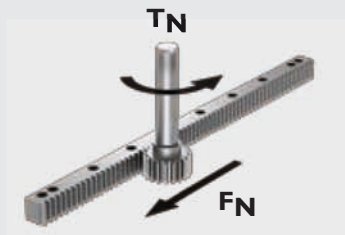

Part No.	Tangentialkraft FN (N)	Moment TN (Nm)	Artikel-Nr. Spansatz	Übertragbares Moment (Nm)
I41551	4277	72	I40001	75
I41552	4017	96	I40002	221
I41553	3888	121	I40002	229
I42051	7746	173	I40002	219
I42052	7472	238	I40002	229
I42053	7472	238	409031	588
I42054	7472	238	I40004	481
I42055	7269	301	I40004	498
I42551	10363	275	I40002	224
I42552	10331	343	I40002	230
I42553	10331	343	I40004	484
I43051	14666	467	I40002	229
I43052	14666	467	I40003	341
I43053	14666	467	409031	588
I43054	14666	467	I40004	481
I43055	15200	605	I40002	234
I43056	15200	605	I40003	350
I43057	15200	605	409031	605
I43058	15200	605	I40004	496
I43059	15200	605	I40004	645

Schräg verzahnt, Modulteilung

Dentures oblique, à pas Module

Helical tooth, Modular pitch

Gehärtet und geschliffen

Material: 16MnCr5 DIN 1.7131
Zahnung: Eingriffswinkel $\alpha = 20^\circ$
 schrägverzahnt
 Schrägungswinkel $\beta = 19^\circ 31'41''$
 gehärtet (ca. HRC 60)
 und ballig geschliffen
Qualität: 6f24 DIN 3962/63/67
f_p (mm): Teilungs-Einzelabweichung
 Modul ≤ 3 ; 0.006
 Modul > 3 ; 0.008

Trempées et réctifiées

Matière: 16MnCr5 DIN 1.7131
Denture: angle de pression $\alpha = 20^\circ$
 à denture oblique
 angle d'hélice $\beta = 19^\circ 31'41''$
 trempée (ca. HRC 60)
 rectifiée et bombée
Qualité: 6f24 DIN 3962/63/67
f_p (mm): Erreur individuelle de pas
 Modul ≤ 3 ; 0.006
 Modul > 3 ; 0.008

Hardened and ground

Material: 16MnCr5 DIN 1.7131
Teeth: pressure angle $\alpha = 20^\circ$
 helical tooth system
 helix angle $\beta = 19^\circ 31'41''$
 hardened (ca. HRC 60)
 ground, crowned
Quality: 6f24 DIN 3962/63/67
f_p (mm): Adjacent pitch error
 Modul ≤ 3 ; 0.006
 Modul > 3 ; 0.008

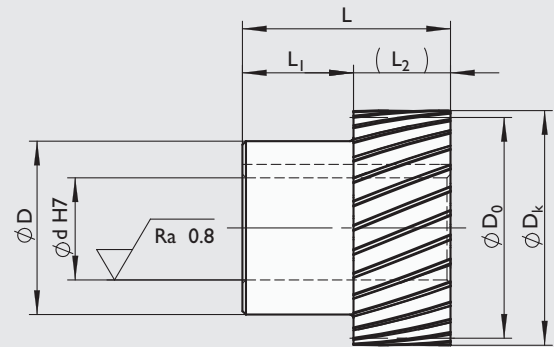
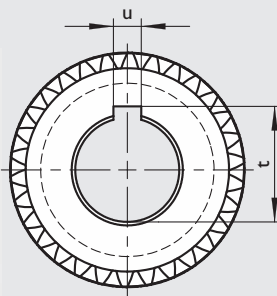

Part No.	P _n	P _t	Modul	z	d ₁	d _k	d ₀	D	L	L ₁	L ₂	t	u	J	m(kg)
144051	12.566	13.333	4	18	32	84.39	76.394	55	75	35	40	35.3	10	1228	1.61
144052	12.566	13.333	4	21	32	97.13	89.127	55	75	35	40	35.3	10	2118	2.12
144053	12.566	13.333	4	21	35	97.13	89.127	55	75	35	40	38.3	10	2092	2.03
144054	12.566	13.333	4	21	40	97.13	89.127	62	75	35	40	43.3	12	2182	2.04
144055	12.566	13.333	4	21	45	97.13	89.127	68	75	35	40	48.8	14	2270	2.01
144056	12.566	13.333	4	24	32	109.86	101.859	55	75	35	40	35.3	10	3482	2.72
144057	12.566	13.333	4	24	35	109.86	101.859	55	75	35	40	38.3	10	3456	2.63
144058	12.566	13.333	4	24	40	109.86	101.859	62	75	35	40	43.3	12	3546	2.63
144059	12.566	13.333	4	24	45	109.86	101.859	68	75	35	40	48.8	14	3635	2.60
144060	12.566	13.333	4	24	55	109.86	101.859	80	80	40	40	59.3	16	3991	2.63
145051	15.708	16.667	5	18	45	105.49	95.493	68	85	35	50	48.8	14	3490	2.73
145052	15.708	16.667	5	24	45	137.32	127.324	68	85	35	50	48.8	14	10369	4.90
145053	15.708	16.667	5	24	55	137.32	127.324	80	90	40	50	59.3	16	10687	4.87
145054	15.708	16.667	5	24	75	137.32	127.324	110	110	60	50	79.9	20	14124	5.62
146051	18.850	20	6	20	55	139.32	127.324	80	100	40	60	59.3	16	12629	5.67
146052	18.850	20	6	20	75	139.32	127.324	110	120	60	60	79.9	20	15894	6.27
146053	18.850	20	6	25	55	171.16	159.155	80	100	40	60	59.3	16	30034	9.03
146054	18.850	20	6	25	75	171.16	159.155	110	120	60	60	79.9	20	33300	9.62
148051	25.133	26.667	8	18	75	168.79	152.789	110	140	60	80	79.9	20	36720	11.06

p (mm): Teilung / graduation / pitch

z: Zähnezahl / nom de dents / number of teeth

J: (10⁻⁶ kg m²) Inertia

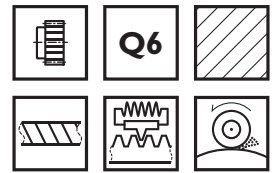

Leistungsdaten

Performance

Performance

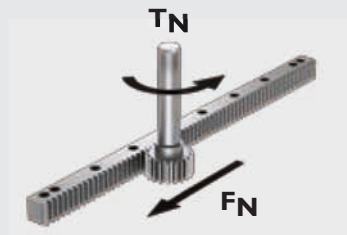

Part No.	Tangentialkraft FN (N)	Moment TN (Nm)	Artikel-Nr. Spansatz	Übertragbares Moment (Nm)
I44051	24420	933	I40004	493
I44052	28655	1277	I40004	503
I44053	28655	1277	I40004	654
I44054	28655	1277	I40005	1284
I44055	28655	1277	412031	1177
I44056	28685	1461	I40004	510
I44057	28685	1461	I40004	664
I44058	28685	1461	I40005	1306
I44059	28685	1461	412031	1200
I44060	28685	1461	I40006	2044
I45051	39413	1882	412031	1189
I45052	45965	2926	412031	1233
I45053	45965	2926	I40006	2111
I45054	45965	2926	I40007	5914
I46051	64990	4137	I40006	2111
I46052	64990	4137	I40007	5914
I46053	66415	5285	I40006	2169
I46054	66415	5285	I40007	6126
I48051	102828	7856	I40007	6090

Schräg verzahnt, Modulteilung

Dentures oblique, à pas Module

Helical tooth, Modular pitch

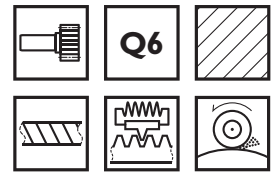

Gehärtet und geschliffen

Material: 16MnCr5 DIN 1.7131
Welle/Bohrung weich

Zahnung: Eingriffswinkel $\alpha = 20^\circ$
schrägverzahnt
Schrägungswinkel $\beta = 19^\circ 31'42''$
gehärtet (ca. HRC 60)
und ballig geschliffen

Qualität: 6f24 DIN 3962/63/67

f_p (mm): Teilungs-Einzelabweichung
Modul ≤ 3 ; 0.006
Modul > 3 ; 0.008

Trempees et réctifiées

Matière: 16MnCr5 DIN 1.7131
arbre/alésage non trempé

Denture: angle de pression $\alpha = 20^\circ$
à denture oblique
angle d'hélice $\beta = 19^\circ 31'42''$
trempée (ca. HRC 60)
réctifiée et bombée

Qualité: 6f24 DIN 3962/63/67

f_p (mm): Erreur individuelle de pas
Modul ≤ 3 ; 0.006
Modul > 3 ; 0.008

Hardened and ground

Material: 16MnCr5 DIN 1.7131
shaft/bore soft

Teeth: pressure angle $\alpha = 20^\circ$
helical tooth system
helix angle $\beta = 19^\circ 31'42''$
hardened (ca. HRC 60)
ground, crowned

Quality: 6f24 DIN 3962/63/67

f_p (mm): Adjacent pitch error
Modul ≤ 3 ; 0.006
Modul > 3 ; 0.008

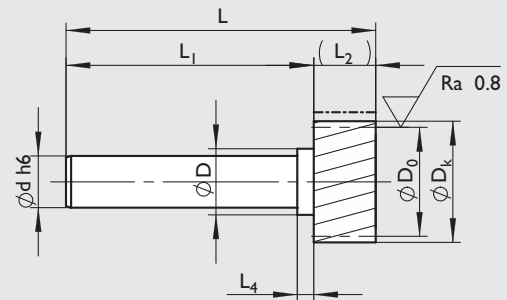

Part No.	P_n	P_t	Modul	z	d	D_k	D_0	D	L	L_1	L_2	L_4	J	m(kg)	
211116	AE 030	4.712	5.00	1.5	16	12	29.36	26.36	16.0	90.0	70.0	20	4.5	8	0.14
211120	AE 045	4.712	5.00	1.5	20	20	34.83	31.83	26.0	110.0	90.0	20	4.5	26	0.34
211216	AE 045	6.283	6.67	2.0	16	20	39.15	35.15	26.0	110.0	90.0	20	8.0	36	0.39
211220	AE 060	6.283	6.67	2.0	20	25	46.44	42.44	32.0	140.0	120.0	20	8.0	90	0.70
211320	AE 060	7.854	8.33	2.5	20	25	58.05	53.05	32.0	145.0	120.0	25	8.0	192	0.91
211416	AE 060	9.425	10.00	3.0	16	25	58.73	52.73	32.0	150.0	120.0	30	8.0	218	0.99
211420	AE 090	9.425	10.00	3.0	20	40	69.66	63.66	50.0	190.0	160.0	30	12.5	726	2.38
211520	AE 090	12.566	13.33	4.0	20	40	92.88	84.88	50.0	200.0	160.0	40	18.0	1954	3.43
211620	AE 120	15.708	16.66	5.0	20	60	116.10	106.10	85.0	310.0	260.0	50	35.0	8484	9.96
211521	AE 120	12.566	13.33	4.0	20	60	92.9	84.88	74.0	310	270.0	40	14.5	4459	7.89
211720	AE 180	18.850	20.00	6.0	20	90	139.30	127.32	105.0	350.0	290.0	60	20.0	27500	20.7
211820	AE 180	25.133	26.66	8.0	20	90	185.70	169.76	105.0	350.0	270.0	80	35.0	65990	28.2
211915	AE 180	31.416	33.33	10.0	15	90	185.20	165.16	105.0	410.0	310.0	100	40.0	66477	31.63

P_n (mm): Normalteilung, pas réel, normal pitch
 P_t (mm): Stirnteilung, pas apparent, transverse

z: Zähnezahl / Nom de dents / Number of teeth

J: (10^{-6} kg m²) Inertia

Schräg verzahnt, Modulteilung

Dentures oblique, à pas Module

Helical tooth, Modular pitch

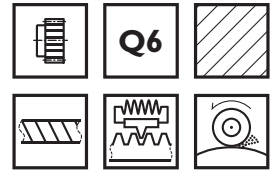

Gehärtet und geschliffen

Material: 16MnCr5 DIN 1.7131
Welle/Bohrung weich

Zahnung: Eingriffswinkel $\alpha = 20^\circ$
schrägverzahnt
Schrägungswinkel $\beta = 19^\circ 31'42''$
gehärtet (ca. HRC 60)
und ballig geschliffen

Qualität: 6f24 DIN 3962/63/67

f_p (mm): Teilungs-Einzelabweichung
Modul ≤ 3 ; 0.006
Modul > 3 ; 0.008

Trempees et réctifiées

Matière: 16MnCr5 DIN 1.7131
arbre/alésage non trempé

Denture: angle de pression $\alpha = 20^\circ$
à denture oblique
angle d'hélice $\beta = 19^\circ 31'42''$
trempée (ca. HRC 60)
réctifiée et bombée

Qualité: 6f24 DIN 3962/63/67

f_p (mm): Erreur individuelle de pas
Modul ≤ 3 ; 0.006
Modul > 3 ; 0.008

Hardened and ground

Material: 16MnCr5 DIN 1.7131
shaft/bore soft

Teeth: pressure angle $\alpha = 20^\circ$
helical tooth system
helix angle $\beta = 19^\circ 31'42''$
hardened (ca. HRC 60)
ground, crowned

Quality: 6f24 DIN 3962/63/67

f_p (mm): Adjacent pitch error
Modul ≤ 3 ; 0.006
Modul > 3 ; 0.008

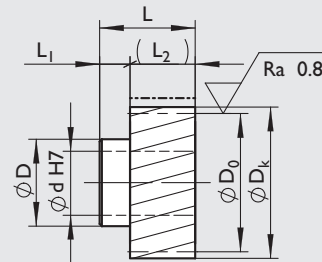

Part No.	p_n	p_t	Modul	z	d	D_k	D_0	D	L	L_1	L_2	J	m(kg)
254512	4.712	5.00	1.5	20	10	34.83	31.83	25.0	28.0	8.0	20	18	0.14
254522	6.283	6.67	2.0	20	15	46.44	42.44	35.0	30.0	10.0	20	60	0.25
254532	7.854	8.33	2.5	20	15	58.05	53.05	40.0	37.0	12.0	25	174	0.50
254542	9.425	10.00	3.0	20	15	69.66	63.66	40.0	44.0	14.0	30	403	0.82
254552	12.566	13.33	4.0	20	30	92.88	84.88	65.0	59.0	19.0	40	1782	1.81
254562	15.708	16.66	5.0	20	40	116.10	106.10	85.0	70.0	20.0	50	5317	3.26
254572	18.850	20.00	6.0	20	50	139.30	127.32	105.0	100.0	40.0	60	15310	7.13
254582	25.133	26.66	8.0	20	50	185.70	169.76	120.0	130.0	50.0	80	58243	16.6
254592	31.416	33.33	10.0	20	50	232.2	212.21	150.0	150.0	50.0	100	173931	32.18

p_n (mm): Normalteilung, pas réel, normal pitch
 p_t (mm): Stirnteilung, pas apparent, transverse

z: Zähnezahl / Nom de dents / Number of teeth

J: (10^{-6} kg m²) Inertia

Schräg verzahnt, Modulteilung

Dentures oblique, à pas Module

Helical tooth, Modular pitch

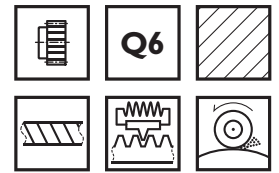

Gehärtet und geschliffen

Material: 16MnCr5 DIN 1.7131
Welle/Bohrung weich

Zahnung: Eingriffswinkel $\alpha = 20^\circ$
schrägverzahnt
Schrägungswinkel $\beta = 19^\circ 31'42''$
gehärtet (ca. HRC 60)
und ballig geschliffen

Qualität: 6f24 DIN 3962/63/67

f_p (mm): Teilungs-Einzelabweichung
Modul ≤ 3 ; 0.006
Modul > 3 ; 0.008

Trempees et réctifiées

Matière: 16MnCr5 DIN 1.7131
arbre/alésage non trempé

Denture: angle de pression $\alpha = 20^\circ$
à denture oblique
angle d'hélice $\beta = 19^\circ 31'42''$
trempée (ca. HRC 60)
réctifiée et bombée

Qualité: 6f24 DIN 3962/63/67

f_p (mm): Erreur individuelle de pas
Modul ≤ 3 ; 0.006
Modul > 3 ; 0.008

Hardened and ground

Material: 16MnCr5 DIN 1.7131
shaft/bore soft

Teeth: pressure angle $\alpha = 20^\circ$
helical tooth system
helix angle $\beta = 19^\circ 31'42''$
hardened (ca. HRC 60)
ground, crowned

Quality: 6f24 DIN 3962/63/67

f_p (mm): Adjacent pitch error
Modul ≤ 3 ; 0.006
Modul > 3 ; 0.008

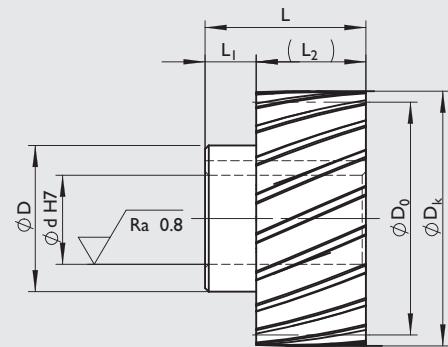
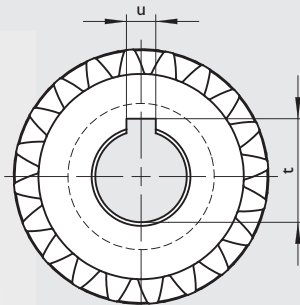

Part No.	P_n	P_t	Modul	z	d_i	D_k	D_0	D	L	L_1	L_2	t	u	J	m(kg)
254513	4.712	5	1.5	20	11	34.83	31.831	25	28	8	20	12.8	4	18	0.13
254514	4.712	5	1.5	20	14	34.83	31.831	25	28	8	20	16.3	5	17	0.12
254515	4.712	5	1.5	20	16	34.83	31.831	25	28	8	20	18.3	5	17	0.11
254523	6.283	62/3	2	20	16	46.44	42.441	35	30	10	20	18.3	5	60	0.25
254524	6.283	62/3	2	20	22	46.44	42.441	35	30	10	20	24.8	6	56	0.21
254525	6.283	62/3	2	20	25	46.44	42.441	35	30	10	20	28.3	8	52	0.18
254533	7.854	81/3	2.5	20	22	58.05	53.052	40	37	12	25	24.8	6	169	0.44
254534	7.854	81/3	2.5	20	25	58.05	53.052	40	37	12	25	28.3	8	164	0.41
254535	7.854	81/3	2.5	20	30	58.05	53.052	40	37	12	25	33.3	8	152	0.34
254543	9.425	10	3	20	22	69.66	63.662	40	44	14	30	24.8	6	397	0.75
254544	9.425	10	3	20	25	69.66	63.662	40	44	14	30	28.3	8	392	0.71
254545	9.425	10	3	20	30	69.66	63.662	40	44	14	30	33.3	8	377	0.64
254553	12.566	131/3	4	20	32	92.88	84.883	65	59	19	40	35.3	10	1802	1.89
254554	12.566	131/3	4	20	35	92.88	84.883	65	59	19	40	38.3	10	1782	1.81
254555	12.566	131/3	4	20	40	92.88	84.883	65	59	19	40	43.3	12	1734	1.68
254563	15.708	162/3	5	20	40	116.10	106.103	85	70	20	50	43.3	12	5515	3.65
254564	15.708	162/3	5	20	45	116.10	106.103	85	70	20	50	48.8	14	5432	3.47
254565	15.708	162/3	5	20	55	116.10	106.103	85	70	20	50	59.3	16	5162	3.04
254573	18.850	20	6	20	55	139.32	127.324	105	100	40	60	59.3	16	15097	6.81
254574	18.850	20	6	20	75	139.32	127.324	105	100	40	60	79.9	20	13375	5.21
254575	18.850	20	6	20	85	139.32	127.324	105	100	40	60	90.4	22	11801	4.23
254583	25.133	262/3	8	20	55	185.77	169.766	120	130	50	80	59.3	16	57913	16.13
254584	25.133	262/3	8	20	75	185.77	169.766	120	130	50	80	79.9	20	55674	14.06
254585	25.133	262/3	8	20	85	185.77	169.766	120	130	50	80	90.4	22	53627	12.78
254593	31.416	331/3	10	20	55	232.21	212.207	150	150	50	100	59.3	16	173618	31.70
254594	31.416	331/3	10	20	75	232.21	212.207	150	150	50	100	79.9	20	171035	29.31
254595	31.416	331/3	10	20	85	232.21	212.207	150	150	50	100	90.4	22	168674	27.84

P_t (mm): Normalteilung, pas réel, normal pitch

z: Zähnezahl / nom de dents / number of teeth

J: (10⁻⁶ kg m²) Inertia

Gerade verzahnt, Metrische Teilung

Dentures droites, à pas métrique

Straight tooth, Metric pitch

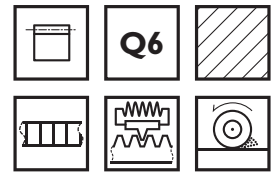

Gehärtet und geschliffen

Material: 58CrMoV4 DIN 1.7792
Profil: allseitig geschliffen
Zahnung: Eingriffswinkel $\alpha = 20^\circ$
 gehärtet (ca. HRC 56)
 und geschliffen
Qualität: 6h23 DIN 3962/63/67
 f_p (mm): Teilungs-Einzelabweichung
 Modul ≤ 3 ; 0.006
 Modul > 3 ; 0.008
 p_f (mm): Toleranz der teilungsgenauen
 Ablängung -0.05/-0.2

Trempées et rectifiées

Matière: 58CrMoV4 DIN 1.7792
Profil: rectifiée toutes les faces
Denture: angle de pression $\alpha = 20^\circ$
 trempée (ca. HRC 56)
 et rectifiée
Qualité: 6h23 DIN 3962/63/67
 f_p (mm): Erreur individuelle de pas
 Modul ≤ 3 ; 0.006
 Modul > 3 ; 0.008
 p_f (mm): Tolérance de coupe par rapport
 au pas -0.05/-0.2

Hardened and ground

Material: 58CrMoV4 DIN 1.7792
Profil: all faces ground
Teeth: pressure angle $\alpha = 20^\circ$
 hardened (ca. HRC 56)
 and ground
Quality: 6h23 DIN 3962/63/67
 f_p (mm): Adjacent pitch error
 Modul ≤ 3 ; 0.006
 Modul > 3 ; 0.008
 p_f (mm): Tolerance of cut for continuous
 mounting -0.05/-0.2

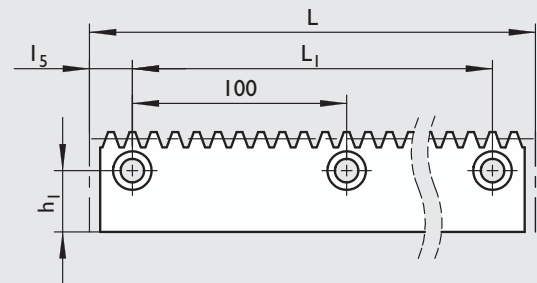
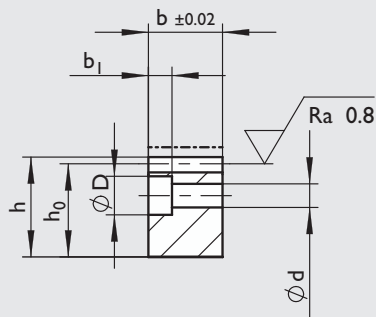

Type	Part No.	L	L ₁	Module	p	h ₀	b	h	h ₁	D	d	b ₁	F _p	m (kg)
LMZ 2.0 G	170020	1030	1000	0.637	2.0	18.86	9.5	19.5	10.5	10	5.8	5.7	0.068	1.40
	170021	330	300	0.637	2.0	18.86	9.5	19.5	10.5	10	5.8	5.7	0.032	0.45
LMZ 5.0 G	170050	1030	1000	1.592	5.0	22.91	14.5	24.5	13.0	11	7.0	6.8	0.043	2.60
	170051	330	300	1.592	5.0	22.91	14.5	24.5	13.0	11	7.0	6.8	0.023	0.85
LMZ 5.5 G	170055	1030	1000	1.592	5.0	27.91	19.5	29.5	15.5	15	9.0	9.0	0.043	4.20
	170056	330	300	1.592	5.0	27.91	19.5	29.5	15.5	15	9.0	9.0	0.023	1.35
LMZ 7.5 G	170075	1230	1200	2.387	7.5	30.61	24.7	33.0	18.5	15	9.0	9.0	0.041	7.00
	170076	330	300	2.387	7.5	30.61	24.7	33.0	18.5	15	9.0	9.0	0.024	1.90
LMZ 10 G	170100	1230	1200	3.183	10.0	43.42	34.6	46.6	28.6	18	11.0	11.0	0.040	13.90
	170101	330	300	3.183	10.0	43.42	34.6	46.6	28.6	18	11.0	11.0	0.025	3.70

p (mm): Teilung, pas, pitch

Gerade verzahnt, Metrische Teilung

Dentures droites, à pas métrique

Straight tooth, Metric pitch

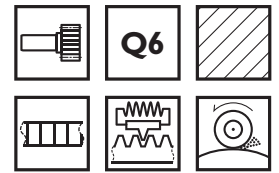

Gehärtet und geschliffen

Material: 16MnCr5 DIN 1.7131
Welle/Bohrung weich

Zahnung: Eingriffswinkel $\alpha = 20^\circ$
gerade verzahnt
gehärtet (ca. HRC 60)
und ballig geschliffen

Qualität: 6f24 DIN 3962/63/67

f_p (mm): Teilungs-Einzelabweichung
Modul ≤ 3 ; 0.006
Modul > 3 ; 0.008

① Material: ETG100 DIN 17210
Zahnung: feinstverzahnt badnitriert

Trempees et réctifiées

Matière: 16MnCr5 DIN 1.7131
arbre/alésage non trempé

Denture: angle de pression $\alpha = 20^\circ$
denture droite
trempée (ca. HRC 60)
rectifiée et bombée

Qualité: 6f24 DIN 3962/63/67

f_p (mm): Erreur individuelle de pas
Modul ≤ 3 ; 0.006
Modul > 3 ; 0.008

① Matière: ETG100 DIN 17210
Denture: trempée par nituration

Hardened and ground

Material: 16MnCr5 DIN 1.7131
shaft/bore soft

Teeth: pressure angle $\alpha = 20^\circ$
straight teeth
hardened (ca. HRC 60)
ground, crowned

Quality: 6f24 DIN 3962/63/67

f_p (mm): Adjacent pitch error
Modul ≤ 3 ; 0.006
Modul > 3 ; 0.008

① Material: ETG100 DIN 17210
Teeth: bath nitridated

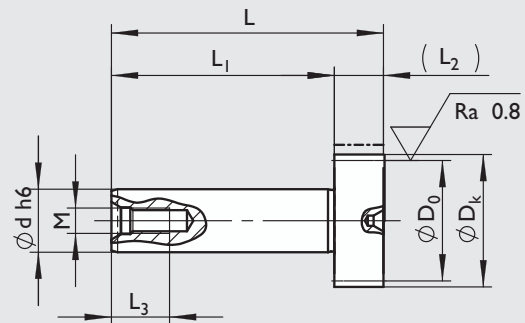

Part No.		p	Modul	z	d	D _k	D ₀	L	L ₁	L ₂	L ₃	M	J	m(kg)
900910 ^①	AE 030	2.0	0.637	30	12	20.4	19.10	70	60.5	9.5	16	M 6	2	0.07
900915	AE 045	5.0	1.592	20	20	35.0	31.83	90	78.5	11.5	19	M 8	19	0.26
900920	AE 045	5.0	1.592	20	20	35.0	31.83	90	75.5	14.5	19	M 8	21	0.28
900925	AE 060	7.5	2.387	20	25	52.5	47.75	108	88.5	19.5	22	M10	104	0.61
900935	AE 090	10.0	3.183	20	40	70.0	63.66	162	132.5	29.5	28	M 12	631	2.03

p (mm): Teilung, pas, pitch

z: Zähnezahl / nom de dents / number of teeth

J: (10^{-6} kg m²) Inertia

Gerade verzahnt, Metrische Teilung

Dentures droites, à pas métrique

Straight tooth, Metric pitch

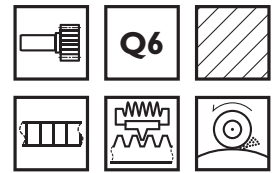

Gehärtet und geschliffen

Material: 16MnCr5 DIN 1.7131
Welle/Bohrung weich

Zahnung: Eingriffswinkel $\alpha = 20^\circ$
gerade verzahnt
gehärtet (ca. HRC 60)
und ballig geschliffen

Qualität: 6f24 DIN 3962/63/67

f_p (mm): Teilungs-Einzelabweichung
Modul ≤ 3 ; 0.006
Modul > 3 ; 0.008

① Material: ETG100 DIN 17210
Zahnung: feinstverzahnt badnitriert

Trempées et réctifiées

Matière: 16MnCr5 DIN 1.7131
arbre/alésage non trempé

Denture: angle de pression $\alpha = 20^\circ$
denture droite
trempée (ca. HRC 60)
rectifiée et bombée

Qualité: 6f24 DIN 3962/63/67

f_p (mm): Erreur individuelle de pas
Modul ≤ 3 ; 0.006
Modul > 3 ; 0.008

① Matière: ETG100 DIN 17210
Denture: trempée par nituration

Hardened and ground

Material: 16MnCr5 DIN 1.7131
shaft/bore soft

Teeth: pressure angle $\alpha = 20^\circ$
straight teeth
hardened (ca. HRC 60)
ground, crowned

Quality: 6f24 DIN 3962/63/67

f_p (mm): Adjacent pitch error
Modul ≤ 3 ; 0.006
Modul > 3 ; 0.008

① Material: ETG100 DIN 17210
Teeth: bath nitrated

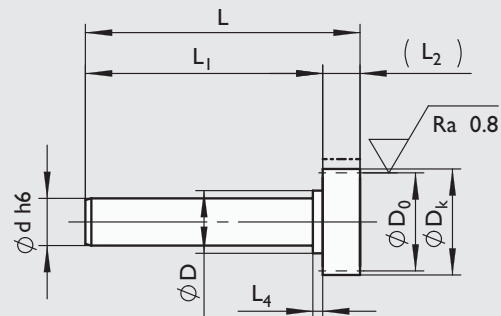

Part No.		p	Modul	z	d	D_k	D_0	D	L	L_1	L_2	L_3	L_4	M	J	m(kg)
403040 ^①	AE 030	2.0	0.637	30	12	20.4	19.10	17	70	60.5	9.5	16	2.5	M 6	2	0.08
403042	AE 030	3.3	1.061	20	12	23.3	21.221	16	70	60.5	9.5		2.5			0.08
403041	AE 030	5.0	1.592	20	12	35.0	31.83	20	90	78.5	11.5		4.5		11	0.15
404540	AE 045	5.0	1.592	20	20	35.0	31.83	26	90	78.5	11.5	19	4.5	M 8	20	0.27
404541	AE 045	5.0	1.592	20	20	35.0	31.83	26	90	75.5	14.5	19	11.5	M 8	23	0.29
404542	AE 045	7.5	2.387	20	20	52.5	47.75	25	108	88.5	19.5		8.0		90	0.50
406040	AE 060	7.5	2.387	20	25	52.5	47.75	32	108	88.5	19.5	22	8.0	M10	108	0.63
406041	AE 060	10.0	3.183	20	25	70.0	63.66	32	162	132.5	29.5		12.5		417	1.27
406042	AE 060	10.0	3.183	14	25	52.5	46.47	32	162	132.5	29.5		12.5		135	0.90
409040	AE 090	10.0	3.183	20	40	70.0	63.66	50	162	132.5	29.5	28	12.5	M12	666	2.10
409041	AE 090	12.5	3.978	20	40	87.5	79.58	50	239	199.0	40.0		20.0		1675	3.61
903547	AE 090	12.5	3.979	14	40	66.0	58.09	45	196	156.0	40.0		18.0		635	2.20
412041	AE 120	12.5	3.979	26	60	111.4	103.45	85	277	237.0	40.0		18.0		4601	8.25
412044	AE 120	16.0	5.093	20	60	112.1	101.86	85	302	252.0	50.0		40.0		7825	9.62
412043	AE 120	20.0	6.366	20	60	140.1	127.32	85	302	242.0	60.0		55.0		16128	12.52
418040	AE 180	20.0	6.366	20	90	140.1	127.32	105	350	290.0	60.0	42	20.0	M20	27500	

p (mm): Teilung, pas, pitch

z: Zähnezahl / nom de dents / number of teeth

J: (10^{-6} kg m²) Inertia

Gerade verzahnt, Metrische Teilung

Dentures droites, à pas métrique

Straight tooth, Metric pitch

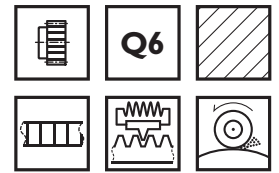

Gehärtet und geschliffen

Material: 16MnCr5 DIN 1.7131
Welle/Bohrung weich

Zahnung: Eingriffswinkel $\alpha = 20^\circ$
gerade verzahnt
gehärtet (ca. HRC 60)
und ballig geschliffen

Qualität: 6f24 DIN 3962/63/67

f_p (mm): Teilungs-Einzelabweichung
Modul ≤ 3 ; 0.006
Modul > 3 ; 0.008

① Material: ETG100 DIN 17210
Zahnung: feinstverzahnt badnitriert

Trempées et rétroifiées

Matière: 16MnCr5 DIN 1.7131
arbre/alésage non trempé

Denture: angle de pression $\alpha = 20^\circ$
denture droite
trempée (ca. HRC 60)
rectifiée et bombée

Qualité: 6f24 DIN 3962/63/67

f_p (mm): Erreur individuelle de pas
Modul ≤ 3 ; 0.006
Modul > 3 ; 0.008

① Matière: ETG100 DIN 17210
Denture: trempée par nituration

Hardened and ground

Material: 16MnCr5 DIN 1.7131
shaft/bore soft

Teeth: pressure angle $\alpha = 20^\circ$
straight teeth
hardened (ca. HRC 60)
ground, crowned

Quality: 6f24 DIN 3962/63/67

f_p (mm): Adjacent pitch error
Modul ≤ 3 ; 0.006
Modul > 3 ; 0.008

① Material: ETG100 DIN 17210
Teeth: bath nitrated

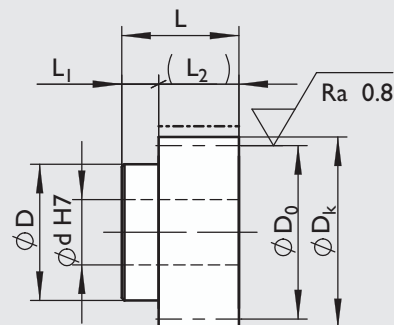

Part No.	p	Modul	z	d	D_k	D_0	D	L	L_1	L_2	J	m(kg)
154020 ^①	2.0	0.637	25	5	17.2	15.92	10	15	5.5	9.5	0.50	0.02
154050	5.0	1.592	20	10	35.0	31.83	25	23	8.5	14.5	14	0.11
154075	7.5	2.387	20	15	52.5	47.75	40	30	10.5	19.5	97	0.33
154100	10.0	3.183	20	15	70.0	63.66	50	43	13.5	29.5	434	0.88
154125	12.5	3.979	20	30	87.5	79.58	65	60	20.0	40.0	1433	1.62
154160	16.0	5.093	20	40	112.1	101.86	85	90	40.0	50.0	5290	3.57
154201	20.0	6.366	20	50	140.1	127.32	105	105	45.0	60.0	15759	7.39
154251	25.0	7.958	20	50	175.1	159.15	135	105	25.0	80.0	43116	11.6

p (mm): Teilung, pas, pitch

z: Zähnezahl / nom de dents / number of teeth

J: (10^{-6} kg m²) Inertia

Gerade verzahnt, Metrische Teilung

Dentures droites, à pas métrique

Straight tooth, Metric pitch

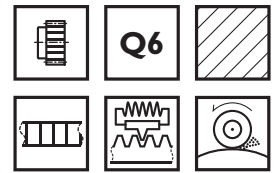

Gehärtet und geschliffen

Material: 16MnCr5 DIN 1.7131
Zahnung: Eingriffswinkel $\alpha = 20^\circ$
gerade verzahnt
gehärtet (ca. HRC 60)
und ballig geschliffen
Qualität: 6f24 DIN 3962/63/67
f_p (mm): Teilungs-Einzelabweichung
Modul ≤ 3 ; 0.006
Modul > 3 ; 0.008

Trempées et réctifiées

Matière: 16MnCr5 DIN 1.7131
Denture: angle de pression $\alpha = 20^\circ$
denture droite
trempée (ca. HRC 60)
rectifiée et bombée
Qualité: 6f24 DIN 3962/63/67
f_p (mm): Erreur individuelle de pas
Modul ≤ 3 ; 0.006
Modul > 3 ; 0.008

Hardened and ground

Material: 16MnCr5 DIN 1.7131
Teeth: pressure angle $\alpha = 20^\circ$
straight teeth
hardened (ca. HRC 60)
ground, crowned
Quality: 6f24 DIN 3962/63/67
f_p (mm): Adjacent pitch error
Modul ≤ 3 ; 0.006
Modul > 3 ; 0.008

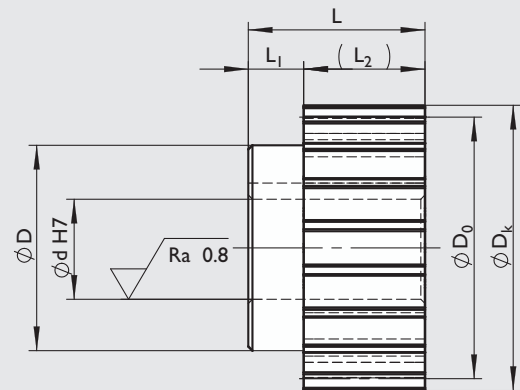
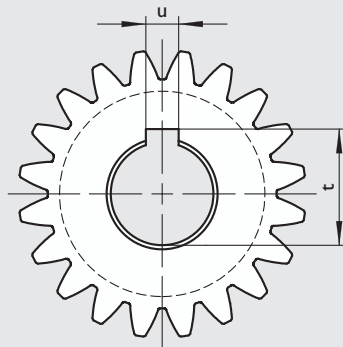

Part No.	p	Modul	z	d	D _k	D ₀	D	L	L ₁	L ₂	t	u	J	m(kg)
154021	2	0.637	25	6	17.19	15.915	10	15	5.5	9.5	7	2	0.49	0.01
154022	2	0.637	25	7	17.19	15.915	10	15	5.5	9.5	8	2	0.48	0.01
154051	5	1.592	20	11	35.01	31.831	25	23	8.5	14.5	12.8	4	14	0.11
154052	5	1.592	20	14	35.01	31.831	25	23	8.5	14.5	16.3	5	13	0.09
154053	5	1.592	20	16	35.01	31.831	25	23	8.5	14.5	18.3	5	13	0.09
154076	7.5	2.387	20	22	52.52	47.746	40	30	10.5	19.5	24.8	6	93	0.29
154077	7.5	2.387	20	25	52.52	47.746	40	30	10.5	19.5	28.3	8	89	0.26
154078	7.5	2.387	20	30	52.52	47.746	40	30	10.5	19.5	33.3	8	80	0.21
154101	10	3.183	20	22	70.03	63.662	50	43	13.5	29.5	24.8	6	428	0.81
154102	10	3.183	20	25	70.03	63.662	50	43	13.5	29.5	28.3	8	423	0.77
154103	10	3.183	20	32	70.03	63.662	50	43	13.5	29.5	35.3	10	401	0.67
154127	12.5	3.979	20	32	87.54	79.577	65	60	20	40	35.3	10	1454	1.69
154128	12.5	3.979	20	35	87.54	79.577	65	60	20	40	38.3	10	1433	1.62
154129	12.5	3.979	20	40	87.54	79.577	65	60	20	40	43.3	12	1384	1.48
154161	16	5.093	20	40	112.05	101.859	85	90	40	50	43.3	12	5544	4.07
154162	16	5.093	20	45	112.05	101.859	85	90	40	50	48.8	14	5438	3.83
154163	16	5.093	20	55	112.05	101.859	85	90	40	50	59.3	16	5090	3.28
154202	20	6.366	20	55	140.06	127.324	105	105	45	60	59.3	16	15528	7.05
154203	20	6.366	20	75	140.06	127.324	105	105	45	60	79.9	20	13719	5.38
154204	20	6.366	20	85	140.06	127.324	105	105	45	60	90.4	22	12066	4.35
154252	25	7.958	20	55	175.07	159.155	135	105	25	80	59.3	16	44930	13.26
154253	25	7.958	20	75	175.07	159.155	135	105	25	80	79.9	20	43121	11.59
154254	25	7.958	20	85	175.07	159.155	135	105	25	80	90.4	22	41468	10.56

p (mm): Teilung, pas, pitch

z: Zähnezahl / nom de dents / number of teeth

J: (10⁻⁶ kg m²) Inertia

Gerade verzahnt, Metrische Teilung

Dentures droites, à pas métrique

Straight tooth, Metric pitch

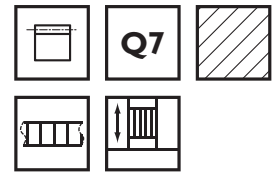

Feinstverzahnt

Material: ETG88 DIN 17210 für RDMZ
Ck45 K+N DIN 1.1191 für DMZ
Profil: allseitig geschliffen
Zahnung: Eingriffswinkel $\alpha = 20^\circ$
feinstverzahnt
Qualität: 7h25 DIN 3962/63/67
p_f (mm): Toleranz der teilungsgenauen
Ablängung -0.05/-0.2
F_p (mm): Teilungs-Gesamtabweichung

Coupe de précision

Matière: ETG88 DIN 17210 pour RDMZ
Ck45 K+N DIN 1.1191 pour DMZ
Profil: rectifiée toutes les faces
Denture: angle de pression $\alpha = 20^\circ$
coupe de précision
Qualité: 7h25 DIN 3962/63/67
p_f (mm): Tolérance de coupe par rapport
au pas -0.05/-0.2
F_p (mm): Erreur totale de pas

Precision cut

Material: ETG88 DIN 17210 for RDMZ
Ck45 K+N DIN 1.1191 for DMZ
Profil: all faces ground
Teeth: pressure angle $\alpha = 20^\circ$
precision cut
Quality: 7h25 DIN 3962/63/67
p_f (mm): Tolerance of cut for continuous
mounting -0.05/-0.2
F_p (mm): Cumulative pitch error

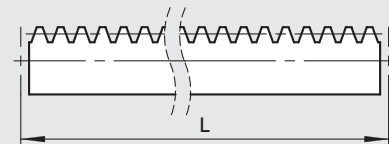
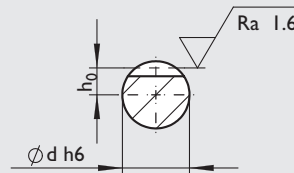

Type	Part No.	L	Module	p	h ₀	d _{h6}	F _p	P _f	m (kg)
RDMZ 2.0	151020	1000	0.637	2.0	4.36	10	0.078	-0.05/-0.21	0.62
RDMZ 5.0	151050	1000	1.592	5.0	5.91	15	0.057	-0.05/-0.52	1.39
RDMZ 7.5	151075	1005	2.387	7.5	7.61	20	0.052	-0.05/-0.78	2.48
RDMZ 10.0	151100	1000	3.183	10.0	11.82	30	0.050	-0.05/-1.05	5.55
RDMZ 12.5	151125	1000	3.979	12.5	16.02	40	0.051	-0.05/-1.31	9.86

p (mm): Teilung / graduation / pitch

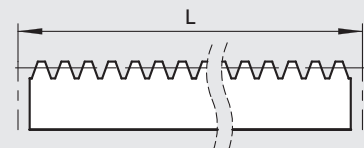
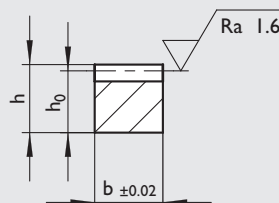
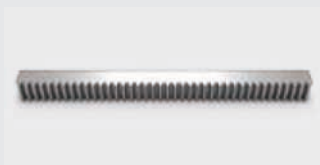

Type	Part No.	L	Module	p	h ₀	b	h	P _f	m (kg)
DMZ 2.0	152020	1000	0.637	2.0	8.86	9.5	9.5	-0.05/-0.21	0.66
DMZ 5.0	152050	1000	1.592	5.0	12.90	14.5	14.5	-0.05/-0.52	1.47
DMZ 7.5	152075	1005	2.387	7.5	17.11	19.5	19.5	-0.05/-0.78	2.63
DMZ 10.0	152100	1000	3.183	10.0	26.32	29.5	29.5	-0.05/-1.05	6.09
DMZ 12.5	152125	1000	3.979	12.5	35.52	39.5	39.5	-0.05/-1.31	11.01

p (mm): Teilung / graduation / pitch

Gerade verzahnt, Metrische Teilung

Dentures droites, à pas métrique

Straight tooth, Metric pitch

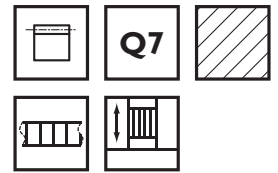

Feinstverzahnt

Material: 58CrMoV4 DIN 1.7792
Profil: allseitig geschliffen
Zahnung: Eingriffswinkel $\alpha = 20^\circ$
 feinstverzahnt
Qualität: 7h25 DIN 3962/63/67
 p_f (mm): Toleranz der teilungsgenaue
 Ablängung -0.05/-0.2
 F_p (mm): Teilungs-Gesamtabweichung

Coupe de précision

Matière: 58CrMoV4 DIN 1.7792
Profil: rectifiée toutes les faces
Denture: angle de pression $\alpha = 20^\circ$
 coupe de précision
Qualité: 7h25 DIN 3962/63/67
 p_f (mm): Tolérance de coupe par rapport
 au pas -0.05/-0.2
 F_p (mm): Erreur totale de pas

Precision cut

Material: 58CrMoV4 DIN 1.7792
Profil: all faces ground
Teeth: pressure angle $\alpha = 20^\circ$
 precision cut
Quality: 7h25 DIN 3962/63/67
 p_f (mm): Tolerance of cut for continuous
 mounting -0.05/-0.2
 F_p (mm): Cumulative pitch error

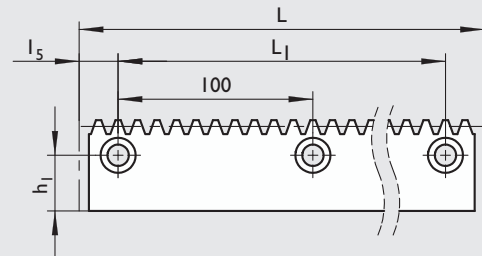
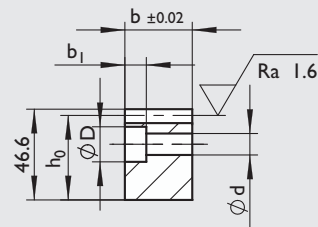

Type	Part No.	L	LI	Module	p	h0	b	h	h1	D	d	b1	Fp	Pf	m (kg)
LMZ 2.0	153020	1 030	1 000	0.637	2.0	18.86	9.5	19.5	10.5	10	5.8	5.7	0.079	-0.05/-0.21	1.40
LMZ 5.0	153050	1 030	1 000	1.592	5.0	22.91	14.5	24.5	13.0	11	7.0	6.8	0.058	-0.05/-0.52	2.60
LMZ 5.5	153055	1 030	1 000	1.592	5.0	27.91	19.5	29.5	15.5	15	9.0	9.0	0.058	-0.05/-0.52	4.20
LMZ 7.5	153075	1 230	1 200	2.387	7.5	30.61	24.7	33.0	18.5	15	9.0	9.0	0.057	-0.05/-0.78	7.00
LMZ 10.0	153100	1 230	1 200	3.183	10.0	43.42	34.6	46.6	28.6	18	11.0	11.0	0.055	-0.05/-1.05	13.90

p: (mm): Teilung / graduation / pitch

Gerade verzahnt, Metrische Teilung

Dentures droites, à pas métrique

Straight tooth, Metric pitch

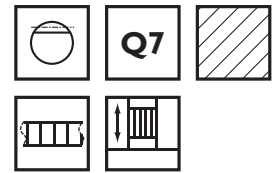

Feinstverzahnt

Material: ETG88 DIN 17210
Profil: geschliffen h6
Zahnung: Eingriffswinkel $\alpha = 20^\circ$
 feinstverzahnt
Qualität: 7h25 DIN 3962/63/67
F_p (mm): Teilungs-Gesamtabweichung

Coupe de précision

Matière: ETG88 DIN 17210
Profil: rectifiée h6
Denture: angle de pression $\alpha = 20^\circ$
 coupe de précision
Qualité: 7h25 DIN 3962/63/67
F_p (mm): Erreur totale de pas

Precision cut

Material: ETG88 DIN 17210
Profile: profile ground h6
Teeth: pressure angle $\alpha = 20^\circ$
 precision cut
Quality: 7h25 DIN 3962/63/67
F_p (mm): Cumulative pitch error

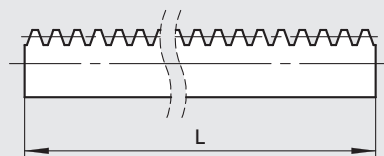
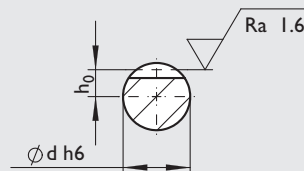

Part No.	p	Modul	L±10	d	h ₀	m (kg)	F _p
I26101	3.141	1.0	250	10	4	0.14	0.030
I26102	3.141	1.0	500	10	4	0.28	0.039
I26103	3.141	1.0	1000	10	4	0.56	0.057
I26104	3.141	1.0	2000	10	4	1.12	0.093
I26111	4.712	1.5	250	15	6	0.32	0.032
I26112	4.712	1.5	500	15	6	0.63	0.041
I26113	4.712	1.5	1000	15	6	1.26	0.059
I26114	4.712	1.5	2000	15	6	2.52	0.096
I26121	6.283	2.0	250	20	8	0.57	0.030
I26122	6.283	2.0	500	20	8	1.13	0.036
I26123	6.283	2.0	1000	20	8	2.26	0.050
I26124	6.283	2.0	2000	20	8	4.52	0.077
I26132	7.854	2.5	500	25	10	1.76	0.038
I26133	7.854	2.5	1000	25	10	3.51	0.050
I26134	7.854	2.5	2000	25	10	7.02	0.075
I26142	9.425	3.0	500	30	12	2.51	0.040
I26143	9.425	3.0	1000	30	12	5.02	0.051
I26144	9.425	3.0	2000	30	12	10.0	0.073
I26152	12.566	4.0	500	40	16	4.53	0.042
I26153	12.566	4.0	1000	40	16	9.06	0.051
I26154	12.566	4.0	2000	40	16	18.10	0.070
I26162	15.708	5.0	500	50	20	6.83	0.040
I26163	15.708	5.0	1000	50	20	13.60	0.048
I26164	15.708	5.0	2000	50	20	27.30	0.062
I26173	18.850	6.0	1000	50	19	14.00	0.051
I26174	18.850	6.0	2000	50	19	28.00	0.065

p: (mm): Teilung / graduation / pitch

Gerade verzahnt, Modulteilung

Dentures droites, à pas Module

Straight tooth, Modular pitch

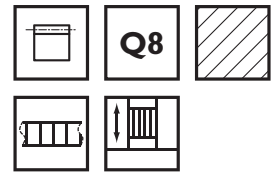

Feinstverzahnt

Material: Ck45K+N DIN 1.1191
Profil: kaltgezogen h11
Zahnung: Eingriffswinkel $\alpha = 20^\circ$
 feinstverzahnt
Qualität: 8h27 DIN 3962/63/67
 p_f (mm): Toleranz der teilungsgenaue
 Ablängung -0.05/-0.2
 F_p (mm): Teilungs-Gesamtabweichung

Coupe de précision

Matière: Ck45K+N DIN 1.1191
Profil: tiré h11
Denture: angle de pression $\alpha = 20^\circ$
 coupe de précision
Qualité: 8h27 DIN 3962/63/67
 p_f (mm): Tolérance de coupe par rapport
 au pas -0.05/-0.2
 F_p (mm): Erreur totale de pas

Precision cut

Material: Ck45K+N DIN 1.1191
Profil: cold formed h11
Teeth: pressure angle $\alpha = 20^\circ$
 precision cut
Quality: 8h27 DIN 3962/63/67
 p_f (mm): Tolerance of cut for continuous
 mounting -0.05/-0.2
 F_p (mm): Cumulative pitch error

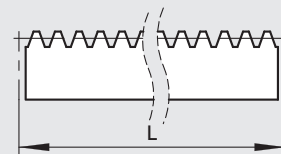
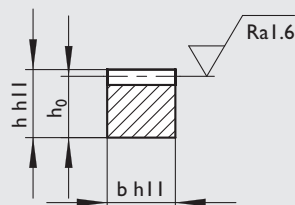
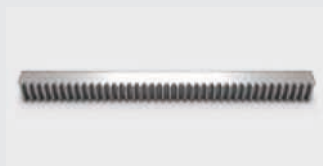

Part No.	p	Modul	L	z	b	h	h_0	F_p	p_f	m(kg)
124101	3.141	1.0	251.33	80	15	15	14.00	0.046	-0.05/-0.33	0.41
124102	3.141	1.0	499.51	159	15	15	14.00	0.062	-0.05/-0.33	0.82
124103	3.141	1.0	999.03	318	15	15	14.00	0.095	-0.05/-0.33	1.65
124104	3.141	1.0	1998.05	636	15	15	14.00	0.160	-0.05/-0.33	3.30
124111	4.712	1.5	249.76	53	17	17	15.50	0.045	-0.05/-0.49	0.52
124112	4.712	1.5	499.51	106	17	17	15.50	0.057	-0.05/-0.49	1.03
124113	4.712	1.5	999.03	212	17	17	15.50	0.082	-0.05/-0.49	2.07
124114	4.712	1.5	1998.05	424	17	17	15.50	0.130	-0.05/-0.49	4.14
124121	6.283	2.0	251.33	40	20	20	18.00	0.042	-0.05/-0.66	0.70
124122	6.283	2.0	502.65	80	20	20	18.00	0.051	-0.05/-0.66	1.40
124123	6.283	2.0	999.03	159	20	20	18.00	0.069	-0.05/-0.66	2.80
124124	6.283	2.0	1998.05	318	20	20	18.00	0.106	-0.05/-0.66	5.70
124132	7.854	2.5	502.65	64	25	25	22.50	0.054	-0.05/-0.82	2.20
124133	7.854	2.5	997.46	127	25	25	22.50	0.070	-0.05/-0.82	4.40
124134	7.854	2.5	2002.77	255	25	25	22.50	0.104	-0.05/-0.82	8.80
124142	9.425	3.0	499.51	53	30	30	27.00	0.057	-0.05/-0.99	3.20
124143	9.425	3.0	999.03	106	30	30	27.00	0.073	-0.05/-0.99	6.40
124144	9.425	3.0	1998.05	212	30	30	27.00	0.104	-0.05/-0.99	12.70
124152	12.566	4.0	502.65	40	40	40	36.00	0.059	-0.05/-1.32	5.70
124153	12.566	4.0	1005.31	80	40	40	36.00	0.073	-0.05/-1.32	11.30
124154	12.566	4.0	1998.05	159	40	40	36.00	0.100	-0.05/-1.32	22.60
124162	15.708	5.0	502.65	32	50	50	45.00	0.057	-0.05/-1.65	8.80
124163	15.708	5.0	1005.31	64	50	50	45.00	0.068	-0.05/-1.65	17.60
124164	15.708	5.0	2010.62	128	50	50	45.00	0.090	-0.05/-1.65	35.30
124173	18.850	6.0	999.03	53	60	60	54.00	0.072	-0.05/-1.98	25.40
124174	18.850	6.0	1998.05	106	60	60	54.00	0.092	-0.05/-1.98	50.90
124183	25.133	8.0	1005.31	40	80	80	72.00	0.067	-0.05/-2.64	45.20
124184	25.133	8.0	2010.62	80	80	80	72.00	0.082	-0.05/-2.64	90.40

p (mm): Teilung / graduation / pitch

z: Zähnezahl / nom de dents / number of teeth

Gerade verzahnt, Modulteilung

Dentures droites, à pas Module

Straight tooth, Modular pitch

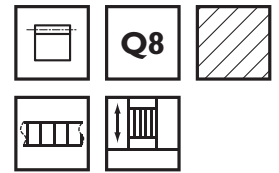

Feinstverzahnt

Material: Ck45 K+N DIN 1.1191
 Profil: kaltgezogen h11
 Zahnung: Eingriffswinkel $\alpha = 20^\circ$
 feinstverzahnt
 Qualität: 8h27 DIN 3962/63/67
 F_p (mm): Teilungs-Gesamtabweichung

Coupe de précision

Matière: Ck45 K+N DIN 1.1191
 Profile: tiré h11
 Denture: angle de pression $\alpha = 20^\circ$
 coupe de précision
 Qualité: 8h27 DIN 3962/63/67
 F_p (mm): Erreur totale de pas

Precision cut

Material: Ck45 K+N DIN 1.1191
 Profil: cold formed h11
 Teeth: pressure angle $\alpha = 20^\circ$
 precision cut
 Quality: 8h27 DIN 3962/63/67
 F_p (mm): Cumulative pitch error

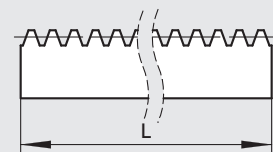
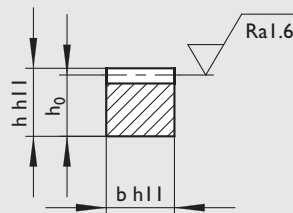
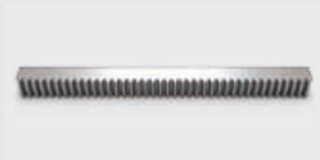

Part No.	p	Modul	$L \pm 10$	b	h	h_0	F_p	m (kg)
I23106	3.141	1.0	500	8	8	7.00	0.062	0.22
I23107	3.141	1.0	1000	8	8	7.00	0.095	0.44
I23202	3.141	1.0	500	10	10	9.00	0.062	0.35
I23203	3.141	1.0	1000	10	10	9.00	0.095	0.71
I23204	3.141	1.0	2000	10	10	9.00	0.160	1.42
I23116	4.712	1.5	500	12	12	10.50	0.057	0.49
I23117	4.712	1.5	1000	12	12	10.50	0.082	0.99
I23126	6.283	2.0	500	16	16	14.00	0.051	0.90
I23127	6.283	2.0	1000	16	16	14.00	0.070	1.80
I23136	7.854	2.5	500	20	20	17.50	0.053	1.40
I23137	7.854	2.5	1000	20	20	17.50	0.070	2.80
I23146	9.425	3.0	500	24	24	21.00	0.057	2.00
I23147	9.425	3.0	1000	24	24	21.00	0.073	4.00
I23156	12.566	4.0	500	32	32	28.00	0.059	3.00
I23157	12.566	4.0	1000	32	32	28.00	0.073	6.00
I23166	15.708	5.0	500	40	40	35.00	0.057	5.50
I23167	15.708	5.0	1000	40	40	35.00	0.068	11.00
I23177	18.850	6.0	1000	50	50	44.00	0.072	17.30
I23178	18.850	6.0	2000	50	50	44.00	0.092	34.60

p: (mm): Teilung / graduation / pitch

Gerade verzahnt, Modulteilung

Dentures droites, à pas Module

Straight tooth, Modular pitch

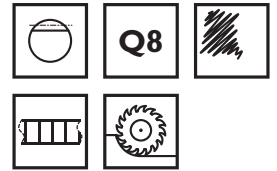

Rostfrei

Material: X10CrNiSi189 DIN 1.4305
Profil: kaltgezogen h9
Zahnung: Eingriffswinkel $\alpha = 20^\circ$
 gefräst
Qualität: 8h27 DIN 3962/63/67
F_p (mm): Teilungs-Gesamtabweichung
 0.15 / 1000mm

Inox

Matière: X10CrNiSi189 DIN 1.4305
Profil: tiré h9
Denture: angle de pression $\alpha = 20^\circ$
 fraisée
Qualité: 8h27 DIN 3962/63/67
F_p (mm): Erreur totale de pas
 0.15 / 1000mm

Stainless steel

Material: X10CrNiSi189 DIN 1.4305
Profil: cold formed h9
Teeth: pressure angle $\alpha = 20^\circ$
 precision cut
Quality: 8h27 DIN 3962/63/67
F_p (mm): Cumulative pitch error
 0.15 / 1000mm

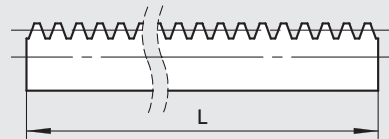
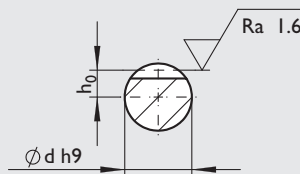

Part No.	p	Modul	L ± 10	d	h ₀	m(kg)
131202	3.141	1.0	500	10	4	0.28
131203	3.141	1.0	1000	10	4	0.56
131204	3.141	1.0	2000	10	4	1.12
131212	4.712	1.5	500	15	6	0.63
131213	4.712	1.5	1000	15	6	1.26
131214	4.712	1.5	2000	15	6	2.52
131222	6.283	2.0	500	20	8	1.13
131223	6.283	2.0	1000	20	8	2.26
131224	6.283	2.0	2000	20	8	4.52
131232	7.854	2.5	500	25	10	1.76
131233	7.854	2.5	1000	25	10	3.51
131234	7.854	2.5	2000	25	10	7.02
131242	9.425	3.0	500	30	12	2.51
131243	9.425	3.0	1000	30	12	5.02
131244	9.425	3.0	2000	30	12	10.0
131252	12.566	4.0	500	40	16	4.53
131253	12.566	4.0	1000	40	16	9.06
131254	12.566	4.0	2000	40	16	18.10
131262	15.708	5.0	500	50	20	6.83
131263	15.708	5.0	1000	50	20	13.60
131264	15.708	5.0	2000	50	20	27.30

p: (mm): Teilung / graduation / pitch

Gerade verzahnt, Metrische Teilung

Dentures droites, à pas métrique

Straight tooth, Metric pitch

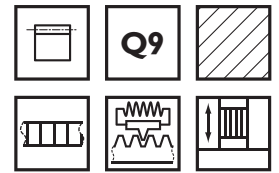

Feinstverzahnt, gehärtet

Material: C45E DIN 1.1191
Profil: gefräst
Zahnung: Eingriffswinkel $\alpha = 20^\circ$
 feinstverzahnt
 gehärtet (ca. HRC 56)
Qualität: 9h25 DIN 3962/63/67
 p_f (mm): Toleranz der teilungsgenauen
 Ablängung -0.05/-0.2
 F_p (mm): Teilungs-Gesamtabweichung

Coupe de précision, Trempée

Matière: C45E DIN 1.1191
Profil: fraisée
Denture: angle de pression $\alpha = 20^\circ$
 coupe de précision
 trempée (ca. HRC 56)
Qualité: 9h25 DIN 3962/63/67
 p_f (mm): Tolérance de coupe par rapport
 au pas -0.05/-0.2
 F_p (mm): Erreur totale de pas

Precision cut, hardened

Material: C45E DIN 1.1191
Profil: milled
Teeth: pressure angle $\alpha = 20^\circ$
 precision cut
 hardened (ca. HRC 56)
Quality: 9h25 DIN 3962/63/67
 p_f (mm): Tolerance of cut for continuous
 mounting -0.05/-0.2
 F_p (mm): Cumulative pitch error

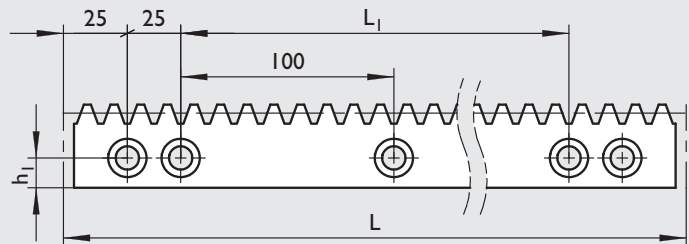
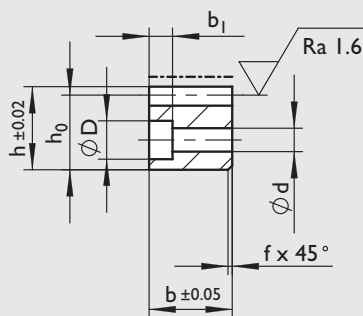

Type	Part No.	L	L ₁	Module	p	h ₀	b	h	h ₁	D	d	b ₁	f	F _p	m (kg)
A 2929	903523	2000	1900	3.183	10.0	25.82	29	29	11.5	15	9.0	9	2	0.142	12.0
	903524	1200	1100	3.183	10.0									0.108	7.2
	903525	800	700	3.183	10.0									0.092	4.8
A 3939	903526	2000	1900	3.979	12.5	35.02	39	39	14.0	18	11.0	11	2	0.137	22.5
	903527	1200	1100	3.979	12.5									0.108	13.5
	903528	800	700	3.979	12.5									0.094	9.8
A 4949	903667	2000	1900	5.093	16.0	43.91	49	49	24.0	20	13.5	13	-	0.121	35.3
	903668	1200	1100	5.093	16.0									0.099	21.2
	903669	800	700	5.093	16.0									0.088	14.2
A 5959	903670	2000	1900	6.366	20.0	52.63	59	59	29.0	20	13.5	13	-	0.125	50.5
	903671	1200	1100	6.366	20.0									0.104	30.3
	903672	800	700	6.366	20.0									0.094	20.2
A 7979	903664	2000	1900	7.958	25.0	71.04	79	79	39.0	26	17.5	17.5	-	0.115	89.3
	903665	1200	1100	7.958	25.0									0.098	53.6
	903666	800	700	7.958	25.0									0.090	35.7

p: (mm): Teilung / graduation / pitch

Gerade verzahnt, Modulteilung

Dentures droites, à pas Module

Straight tooth, Modular pitch

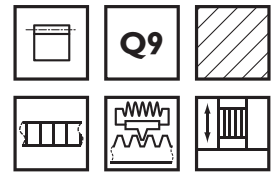

Feinstverzahnt, gehärtet

Material: Ck45K+N DIN 1.1191
Profil: kaltgezogen h11
Zahnung: Eingriffswinkel $\alpha = 20^\circ$
 feinstverzahnt
 gehärtet (ca. HRC 60)
Qualität: 9h27 DIN 3962/63/67
F_p (mm): Teilungs-Gesamtabweichung
p_f (mm): Toleranz der teilungsgenauen
 Ablängung

Coupe de précision, Trempée

Matière: Ck45K+N DIN 1.1191
Profil: tiré h11
Denture: angle de pression $\alpha = 20^\circ$
 taillage de précision
 trempée (ca. HRC 60)
Qualité: 9h27 DIN 3962/63/67
F_p (mm): Erreur totale de pas
p_f (mm): Tolérance de coupe par rapport
 au pas

Precision cut, hardened

Material: Ck45K+N DIN 1.1191
Profil: cold formed h11
Teeth: pressure angle $\alpha = 20^\circ$
 precision cut
 hardened (ca. HRC 60)
Quality: 9h27 DIN 3962/63/67
F_p (mm): Cumulative pitch error
p_f (mm): Tolerance of cut for continuous
 mounting

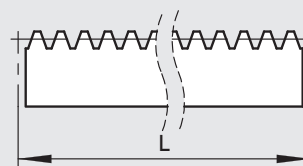
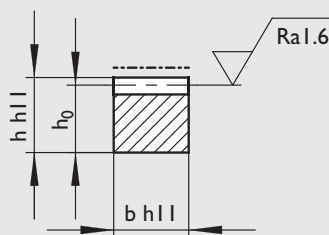
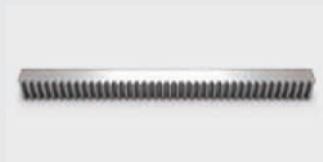

Part No.	p	Modul	L	z	b	h	h ₀	F _p	p _f	m(kg)
I24513	4.712	1.5	999.03	212	17	17	15.50	0.118	-0.05/-0.49	2.07
I24514	4.712	1.5	1998.05	424	17	17	15.50	0.191	-0.05/-0.49	4.14
I24523	6.283	2.0	999.03	159	20	20	18.00	0.100	-0.05/-0.66	2.80
I24524	6.283	2.0	1998.05	318	20	20	18.00	0.155	-0.05/-0.66	5.70
I24533	7.854	2.5	997.46	127	25	25	22.50	0.100	-0.05/-0.82	4.40
I24534	7.854	2.5	2002.77	255	25	25	22.50	0.150	-0.05/-0.82	8.80
I24543	9.425	3.0	999.03	106	30	30	27.00	0.103	-0.05/-0.99	6.40
I24544	9.425	3.0	1998.05	212	30	30	27.00	0.147	-0.05/-0.99	12.70
I24553	12.566	4.0	1005.31	80	40	40	36.00	0.101	-0.05/-1.32	11.30
I24554	12.566	4.0	1998.05	159	40	40	36.00	0.136	-0.05/-1.32	22.60
I24563	15.708	5.0	1005.31	64	50	50	45.00	0.094	-0.05/-1.65	17.60
I24564	15.708	5.0	2010.62	128	50	50	45.00	0.122	-0.05/-1.65	35.30
I24573	18.850	6.0	999.03	53	60	60	54.00	0.101	-0.05/-1.98	17.30
I24574	18.850	6.0	1998.05	106	60	60	54.00	0.128	-0.05/-1.98	34.60

p: (mm): Teilung / graduation / pitch

z: Zähnezahl / nom de dents / number of teeth

Gerade verzahnt, Modulteilung

Dentures droites, à pas Module

Straight tooth, Modular pitch

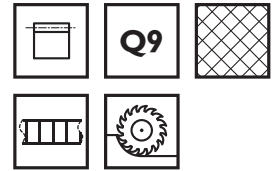

Gefräst

Material: Polyamid PA 6
Profil: gefräst
Zahnung: Eingriffswinkel $\alpha = 20^\circ$
 gefräst
Qualität: 9h27 DIN 3962/63/67
F_p (mm): Teilungs-Gesamtabweichung
 0.15 / 1000mm

Fraissées

Matière: Polyamide PA 6
Profil: fraisée
Denture: angle de pression $\alpha = 20^\circ$
 fraisée
Qualité: 9h27 DIN 3962/63/67
F_p (mm): Erreur totale de pas
 0.15 / 1000mm

Milled

Material: Polyamide PA 6
Profil: milled
Teeth: pressure angle $\alpha = 20^\circ$
 precision cut
Quality: 9h27 DIN 3962/63/67
F_p (mm): Cumulative pitch error
 0.15 / 1000mm

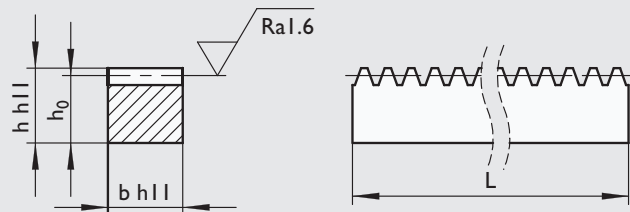
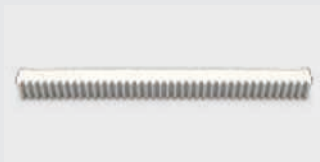

Part No.	p	Modul	L ± 10	b	h	h ₀	m (kg)
I27103	3.141	1.0	1000	15	15	14.00	0.18
I27104	3.141	1.0	2000	15	15	14.00	0.36
I27113	4.712	1.5	1000	17	17	15.50	0.27
I27114	4.712	1.5	2000	17	17	15.50	0.54
I27123	6.283	2.0	1000	20	20	18.00	0.29
I27124	6.283	2.0	2000	20	20	18.00	0.58
I27133	7.854	2.5	1000	25	25	22.50	0.62
I27134	7.854	2.5	2000	25	25	22.50	1.24
I27143	9.425	3.0	1000	30	30	27.00	0.92
I27144	9.425	3.0	2000	30	30	27.00	1.84
I27153	12.566	4.0	1000	40	40	36.00	1.60
I27154	12.566	4.0	2000	40	40	36.00	3.20
I27163	15.708	5.0	1000	50	50	45.00	2.60
I27164	15.708	5.0	2000	50	50	45.00	5.20

p: (mm): Teilung / graduation / pitch

Gerade verzahnt, Modulteilung

Dentures droites, à pas Module

Straight tooth, Modular pitch

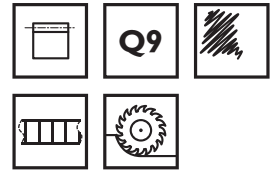

Rostfrei, gefräst

Material: X10CrNiSi189 DIN 1.4305
Profil: kaltgezogen h11
Zahnung: Eingriffswinkel $\alpha = 20^\circ$
 gefräst
Qualität: 9h27 DIN 3962/63/67
F_p (mm): Teilungs-Gesamtabweichung
 0.15 / 1000mm

Inox, fraisée

Matière: X10CrNiSi189 DIN 1.4305
Profil: tiré h11
Denture: angle de pression $\alpha = 20^\circ$
 fraisée
Qualité: 9h27 DIN 3962/63/67
F_p (mm): Erreur totale de pas
 0.15 / 1000mm

Stainless steel, milled

Material: X10CrNiSi189 DIN 1.4305
Profil: cold formed h11
Teeth: pressure angle $\alpha = 20^\circ$
 milled
Quality: 9h27 DIN 3962/63/67
F_p (mm): Cumulative pitch error
 0.15 / 1000mm

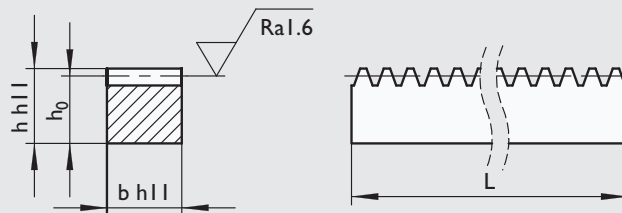
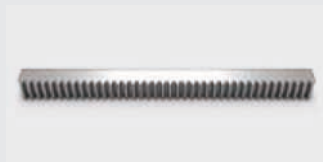

Part No.	p	Modul	L±10	b	h	h ₀	m (kg)
I30506	3.141	1.0	500	8	8	7.00	0.22
I30507	3.141	1.0	1000	8	8	7.00	0.44
I30516	4.712	1.5	500	12	12	10.50	0.49
I30517	4.712	1.5	1000	12	12	10.50	0.99
I30526	6.283	2.0	500	16	16	14.00	0.90
I30527	6.283	2.0	1000	16	16	14.00	1.80
I30536	7.854	2.5	500	20	20	17.50	1.40
I30537	7.854	2.5	1000	20	20	17.50	2.80
I30546	9.425	3.0	500	24	24	21.00	2.00
I30547	9.425	3.0	1000	24	24	21.00	4.00
I30556	12.566	4.0	500	30	30	26.00	3.00
I30557	12.566	4.0	1000	30	30	26.00	6.00
I30566	15.708	5.0	500	40	40	35.00	5.50
I30567	15.708	5.0	1000	40	40	35.00	11.00

p: (mm): Teilung / graduation / pitch

Gerade verzahnt, Modulteilung Dentures droites, à pas Module Straight tooth, Modular pitch

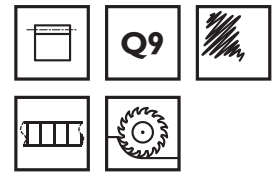

Rostfrei, gefräst

Material: X10CrNiS189 DIN 1.4305
Profil: kaltgezogen h11
Zahnung: Eingriffswinkel $\alpha = 20^\circ$
 gefräst
Qualität: 9h27 DIN 3962/63/67
 p_f (mm): Toleranz der teilungsgenauen
 Ablängung
 F_p (mm): Teilungs-Gesamtabweichung

Inox, fraisée

Matière: X10CrNiS189 DIN 1.4305
Profil: tiré h11
Denture: angle de pression $\alpha = 20^\circ$
 fraisée
Qualité: 9h27 DIN 3962/63/67
 p_f (mm): Tolérance de coupe par rapport
 au pas
 F_p (mm): Erreur totale de pas

Stainless steel, milled

Material: X10CrNiS189 DIN 1.4305
Profil: cold formed h11
Teeth: pressure angle $\alpha = 20^\circ$
 milled
Quality: 9h27 DIN 3962/63/67
 p_f (mm): Tolerance of cut for continuous
 mounting
 F_p (mm): Cumulative pitch error

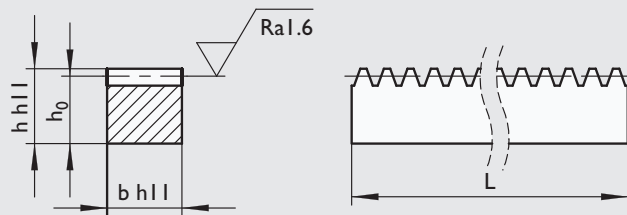
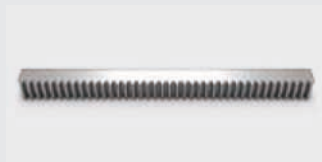

Part No.	p	Modul	L	z	b	h	h_0	F_p	p_f	m (kg)
130502	3.141	1.0	499.51	159	15	15	14.00	0.062	-0.05/-0.33	0.82
130503	3.141	1.0	999.03	318	15	15	14.00	0.095	-0.05/-0.33	1.65
130504	3.141	1.0	1998.05	636	15	15	14.00	0.160	-0.05/-0.33	3.30
130512	4.712	1.5	499.51	106	16	16	15.50	0.057	-0.05/-0.49	1.03
130513	4.712	1.5	999.03	212	16	16	15.50	0.082	-0.05/-0.49	2.07
130514	4.712	1.5	1998.05	424	16	16	15.50	0.130	-0.05/-0.49	4.14
130522	6.283	2.0	502.65	80	20	20	18.00	0.051	-0.05/-0.66	1.40
130523	6.283	2.0	999.03	159	20	20	18.00	0.069	-0.05/-0.66	2.80
130524	6.283	2.0	1998.05	318	20	20	18.00	0.106	-0.05/-0.66	5.70
130532	7.854	2.5	502.65	64	25	25	22.50	0.054	-0.05/-0.82	2.20
130533	7.854	2.5	997.46	127	25	25	22.50	0.070	-0.05/-0.82	4.40
130534	7.854	2.5	2002.77	255	25	25	22.50	0.104	-0.05/-0.82	8.80
130542	9.425	3.0	499.51	53	30	30	27.00	0.057	-0.05/-0.99	3.20
130543	9.425	3.0	999.03	106	30	30	27.00	0.073	-0.05/-0.99	6.40
130544	9.425	3.0	1998.05	212	30	30	27.00	0.104	-0.05/-0.99	12.70
130552	12.566	4.0	502.65	40	40	40	36.00	0.059	-0.05/-1.32	5.70
130553	12.566	4.0	1005.31	80	40	40	36.00	0.073	-0.05/-1.32	11.30
130554	12.566	4.0	1998.05	159	40	40	36.00	0.100	-0.05/-1.32	22.60
130562	15.708	5.0	502.65	32	50	50	45.00	0.057	-0.05/-1.65	8.80
130563	15.708	5.0	1005.31	64	50	50	45.00	0.068	-0.05/-1.65	17.60
130564	15.708	5.0	2010.62	128	50	50	45.00	0.090	-0.05/-1.65	35.30

p: (mm): Teilung / graduation / pitch

z: Zähnezahl / nom de dents / number of teeth

Zahnstangen für Linearführungen

Crémaillères pour guidage linéaires

Racks for linear guideways

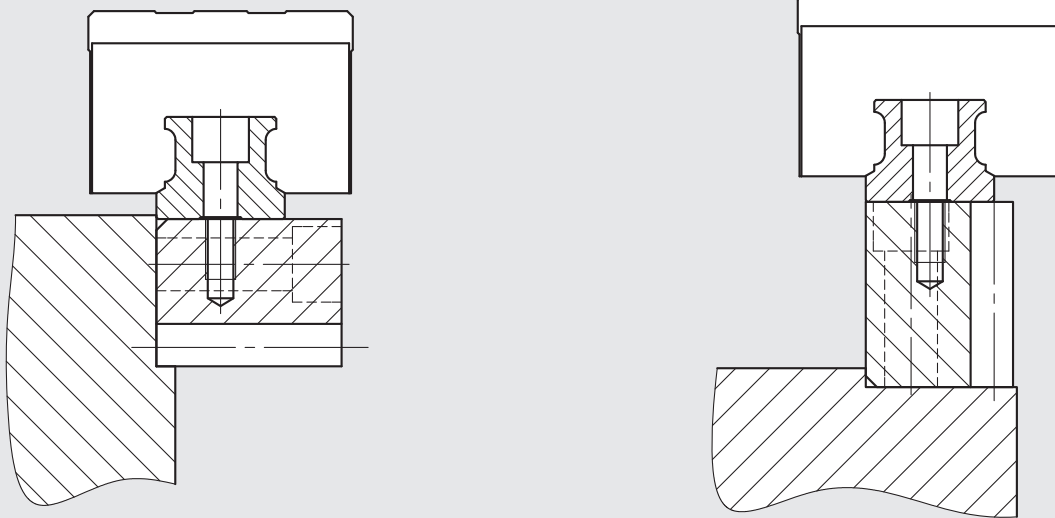

Bei Anfragen von Zahnstangen für Linearführungen folgender Lieferanten HIWIN, IKO, INA, NSK, SCHNEEBERGER, SKF, STAR, THK in den Baugössen 15,20,25,30,35,45 bitten wir Sie, sich mit unseren GÜDEL Vertriebsgesellschaften in Verbindung zu setzen.

En cas de demandes-d'offre pour des crémaillères en combinaison avec des guidages linéaires des fournisseurs HIWIN, IKO, INA, NSK, SCHNEEBERGER, SKF, STAR, THK pour les tailles 15,20,25,30,35,45 veuillez contacter svp nos bureaux de vente GÜDEL.

For inquires regarding racks in combination with linear guideways of the following suppliers HIWIN, IKO, INA, NSK, SCHNEEBERGER, SKF, STAR, THK for the sizes 15,20,25,30,35,45 please contact our GÜDEL sales departments.

Berechnungsbeispiel

Exemple de calcul

Calculation Example

1. Gegebene Grössen

Axiallast

$$\begin{aligned} m &= 500 \text{ kg} \\ v &= 1.25 \text{ m/s} \\ t_a &= 0.31 \text{ s} \\ g &= 9.81 \text{ m/s}^2 \\ \mu &= 0.10 \\ n_1 &= 3000 \text{ l/min} \\ f_B &= 1.2 \\ S_B &= 1.0 \end{aligned}$$

2. Gesucht

Dimension von Zahnstangen, Zahnritzel

3. Berechnung der Kräfte auf das Antriebssystem

3.1 Beschleunigung

$$a = \frac{v}{t_a} = \frac{1.25}{0.31} = 4 \text{ m/s}^2$$

3.2 Vorschubkräfte horizontal

$$F_{Nh} = m \cdot (g \cdot \mu + a) = 500 \cdot (9.81 \cdot 0.1 + 4) = 2490.5 \text{ N}$$

3.3 Vorschubkräfte vertikal

$$F_{Nv} = m \cdot g + m \cdot a$$

3.4 Erforderliche Antriebskraft horizontal

$$F_{\text{erf}} = f_B \cdot F_{Nh} = 1.2 \cdot 2490.5 = 2989.0 \text{ N}$$

3.5 Erforderliche Antriebskraft vertikal

$$F_{\text{erf}} = f_B \cdot F_{Nv}$$

3.6 Erforderliche Drehmoment horizontal

$$T_{\text{Nerf}} = F_{Nh} \cdot \frac{d_0}{2000} = \text{Nm}$$

3.7 Erforderliche Drehmoment vertikal

$$T_{\text{Nerf}} = F_{Nv} \cdot \frac{d_0}{2000} = \text{Nm}$$

4. Wahl von Zahnstangen und Ritzel

4.1 $F_N + T_N$ aus Tabelle Seite 10-12 mit $S_B=1.0$
 Bedingung: $F_{TN} \geq T_{\text{Nerf}}$
 Ritzel
 Zahnstange

1. Données

Charge axiale

$$\begin{aligned} m &= 500 \text{ kg} \\ v &= 1.25 \text{ m/s} \\ t_a &= 0.31 \text{ s} \\ g &= 9.81 \text{ m/s}^2 \\ \mu &= 0.10 \\ n_1 &= 3000 \text{ l/min} \\ f_B &= 1.2 \\ S_B &= 1.0 \end{aligned}$$

2. Demandés

Dimension du système d'entraînement et du réducteur.

3. Forces sur le système d'entraînement

3.1 Accélération

$$a = \frac{v}{t_a} = \frac{1.25}{0.31} = 4 \text{ m/s}^2$$

3.2 Forces de traction horizontale

$$F_{Nh} = m \cdot (g \cdot \mu + a) = 500 \cdot (9.81 \cdot 0.1 + 4) = 2490.5 \text{ N}$$

3.3 Forces de traction vertical

$$F_{Nv} = m \cdot g + m \cdot a$$

3.4 Forces de traction exigée horizontale

$$F_{\text{erf}} = f_B \cdot F_{Nh} = 1.2 \cdot 2490.5 = 2989.0 \text{ N}$$

3.5 Forces de traction exigée vertical

$$F_{\text{erf}} = f_B \cdot F_{Nv}$$

3.6 Couple nécessaire horizontale

$$T_{\text{Nerf}} = F_{Nh} \cdot \frac{d_0}{2000} = \text{Nm}$$

3.7 Couple nécessaire vertical

$$T_{\text{Nerf}} = F_{Nv} \cdot \frac{d_0}{2000} = \text{Nm}$$

4. Sélection crémaillère et pignon

4.1 $F_N + T_N$ de la table Page 10-12 avec $S_B=1.0$
 Condition: $F_{TN} \geq T_{\text{Nerf}}$
 Pignon
 Crémaillères

1. Determine knowns

Axial load

$$\begin{aligned} m &= 500 \text{ kg} \\ v &= 1.25 \text{ m/s} \\ t_a &= 0.31 \text{ s} \\ g &= 9.81 \text{ m/s}^2 \\ \mu &= 0.10 \\ n_1 &= 3000 \text{ l/min} \\ f_B &= 1.2 \\ S_B &= 1.0 \end{aligned}$$

2. Determine unknowns

Dimension of rack, pinion and servo gear box.

3. Forces acting on the drive system

3.1 Acceleration

$$a = \frac{v}{t_a} = \frac{1.25}{0.31} = 4 \text{ m/s}^2$$

3.2 Horizontal traction forces

$$F_{Nh} = m \cdot (g \cdot \mu + a) = 500 \cdot (9.81 \cdot 0.1 + 4) = 2490.5 \text{ N}$$

3.3 Vertical traction forces

$$F_{Nv} = m \cdot g + m \cdot a$$

3.4 Horizontal required drive forces

$$F_{\text{erf}} = f_B \cdot F_{Nh} = 1.2 \cdot 2490.5 = 2989.0 \text{ N}$$

3.5 Vertical required drive forces

$$F_{\text{erf}} = f_B \cdot F_{Nv}$$

3.6 Horizontal output torque

$$T_{\text{Nerf}} = F_{Nh} \cdot \frac{d_0}{2000} = \text{Nm}$$

3.7 Vertical output torque

$$T_{\text{Nerf}} = F_{Nv} \cdot \frac{d_0}{2000} = \text{Nm}$$

4. Selection of racks and pinions

4.1 $F_N + T_N$ from table Page 10-12 with $S_B=1.0$
 Condition: $F_{TN} \geq T_{\text{Nerf}}$
 Pinion
 Rack

Um Ihnen bei der Auslegung des Antriebes behilflich zu sein, lassen Sie uns folgende Angaben zukommen:

1. Applikation

- Beschreibung der Anwendung

2. Anforderungen an Antrieb

- Kleine Abmasse mit hohen übertragbaren Momenten
- Positioniergenauigkeit
- Laufruhe
- Anzahl Lastwechsel / h

3. Betriebsdaten

- Dauerbetrieb oder intermittierender Betrieb (Anläufe / h)
- Einschaltdauer
- Eintriebsdrehzahl
- Art der Eintriebsdrehzahl (variabel, kontinuierlich)
- Gewünschte Abtriebsdrehzahl
- Zu bewegende Masse
- Gewünschte Geschwindigkeit der bewegten Masse
- Beschleunigungszeit
- Art des Einbaus des Zahnstangensystems

4. Umgebung

- Umgebungstemperatur
- Feuchtigkeit

5. Konfiguration

- Zubehör
- Anbaugeometrie Motor
- Art des Abtriebs
- Spezielle Modifikationen, Dimensionen oder Eigenschaften

Pour vous aider à sélectionner votre système d'entraînement fournissez nous les suivantes spécifications:

1. Application

- Description de l'application.

2. Caractéristiques demandés

- Hautes couples transmissible avec petites dimensions
- Précision de positionnement
- Roulement
- Changement de charge / h

3. Indications

- Fréquence de démarrage (démarrage / h)
- Cycle de service
- Vitesse d'entrée
- Caractéristique de la vitesse d'entrée (variable, continuuel)
- Vitesse de sortie exigée
- Poids à bouger
- Vitesse exigée du poids
- Temps d'accélération
- Position de montage du système d'entraînement

4. Environnement

- Température ambiante
- Humidité

5. Configuration

- Accessoires
- Dimensions pour montage du moteur
- Modifications spéciales, dimensions ou propriétés

To provide the right drive system for your application send us following specifications:

1. Application

- Description of application.

2. Required features

- Small sizes with high torques
- Positioning accuracy
- Rolling
- Shock loading

3. Loading

- Continuous or intermittent (start per hour)
- Duty cycle
- Preferred input speed
- Variable or continuous input speed
- Desired output speed
- Moving mass
- Preferred speed of the moved mass
- Acceleration time
- Overhung and thrust loading on shafts
- Arrangement type of the drive system

4. Environmental

- Temperature
- Wet or spray exposure

5. Configuration

- Accessories
- Flange mounting provisions for the drive motor
- Specification of output
- Special modifications, dimensions or features

Wartung und Schmierung

Entretien et Lubrification

Maintenance and lubrication

Zahnstange und Ritzel

Zahnräder und Zahnstangen sind regelmässig mit Fett nachzuschmieren. Für eine Ölschmierung kann ein Filzzahnrad Fig.① verwendet werden. Die Einbaulage ist beliebig. Das Filzzahnrad ist im Eingriff mit der Verzahnung der Zahnstange und überträgt den Schmierstoff. Auf diese Weise wird ein gleichmässiger Schmierfilm aufgetragen. Nach Bedarf wird der auf der Achse angebrachte Schmiernippel zur Nachschmierung verwendet.

Die Zuführung des Schmierstoffs erfolgt durch die Achse Fig.①. Diese kann an eine Zentralschmierung angeschlossen werden, dadurch wird eine automatische Schmierung erreicht Fig.①.

Eine Nachschmierung wird alle 100km oder 150h empfohlen.

Kennzeichnung Schmiernippel: roter Ring

Mit dem nachfüllbaren autonomen Schmierstoffspender steht ein automatisches Nachschmier-system zur Verfügung. Zusammen mit dem Kolbenverteiler können mehrere Schmierstellen versorgt werden. Die Erstbefüllung erfolgt mit Glygoyl 460.

Crémaillère et pignon

Le pignon et la crémaillère doivent faire l'objet d'un entretien régulier, et seront graissés avec de la graisse haute pression.

Pour la lubrification avec de l'huile, un pignon en feutre Fig.① imbibé d'huile lubrifie la crémaillère.

Le remplissage d'huile se fait par l'axe du support Fig.① du pignon en feutre. Suivant les besoins on utilise pour la relubrification le graisseur monté sur l'axe.

Un regraisage est recommandé tous les 100km ou 150h.

Identification du graisseur: bague rouge

Un distributeur de lubrifiant autonome et rechargeable, permet une relubrification automatique de plusieurs unités Fig.①.

Le plein initial se fait avec du Glygoyl 460.

Rack and pinion

The pinion and the rack must be maintained regularly, and be re-lubricated with an adhesive grease.

In case of using oil as a lubricant an oiled felt pinion Fig.① is used.

The lubricant is applied through the felt pinion carrier Fig.①. This ensures a uniform distribution of the oil on the rack.

Regreasing is recommended every 100km or 150h.

Identification of grease nipple: red ring

The lube nipple fitted to the felt pinion carrier is used for refilling of the oil.

An automatic re-lubrication of several felt pinions is available utilising a central lubrication system Fig.①.

The first filling is carried out using Glygoyl 460.

Filzritzel für die Schmierung

Gerade verzahnt / Denture droite / Straight tooth

Part. No.	Modul	z	D ₀	D _K	D	L ₂
230810	1.0	20	20.0	22.0	8	10
230811	1.5	15	22.5	25.5	12	12
230812	2.0	15	30.0	34.0	15	15
230813	2.5	15	37.5	42.5	20	20
230814	3.0	15	45.0	51.0	25	25
230815	4.0	15	60.0	68.0	30	30
230816	5.0	15	75.0	85.0	40	40
230817	6.0	15	90.0	102.0	50	50
230818	8.0	15	120.0	136.0	50	60
230819	10.0	15	150.0	170.0	80	90

Schräg verzahnt / Denture oblique / Helical tooth

Part. No.	Modul	z	D ₀	D _K	D	L ₂
230820	1.5	16	25.46	28.46	12	15
230821	2.0	16	33.95	37.95	15	20
230822	2.5	16	42.44	47.44	20	25
230823	3.0	16	50.93	56.93	30	30
230824	4.0	16	67.91	75.91	40	40
230825	5.0	16	84.88	94.88	50	50
230826	6.0	16	101.85	113.85	50	60
230827	8.0	16	135.81	151.81	50	60
230828	10.0	16	169.77	189.77	80	90

Pignon en feutre pour la lubrification

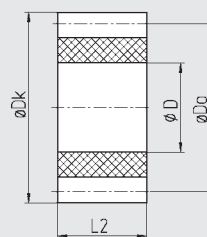

Felt pinion for lubrication

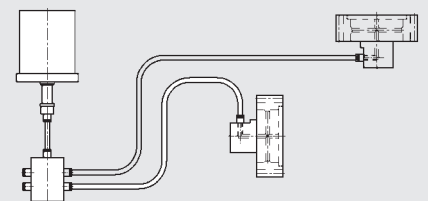

Gerade verzahnt / Denture droite / Straight tooth

Part. No.	p	Modul	z	D ₀	D _K	D	L ₂
230800	2.0	0.637	30	19.10	20.4	8	10
230801	5.0	1.592	15	23.87	27.1	12	12
230802	5.0	1.592	15	23.87	27.1	12	15
230803	7.5	2.387	15	35.81	40.6	20	20
230804	10.0	3.183	15	47.75	54.1	30	30
230805	12.5	3.979	15	59.68	67.6	40	40
230806	16.0	5.093	15	76.40	86.6	50	50
230807	20.0	6.366	16	105.68	118.4	50	60
230808	25.0	7.958	12	100.26	116.2	50	60

Achsen für Filzritzel

Axes pour pignon en feutre

Carrier for felt pinion

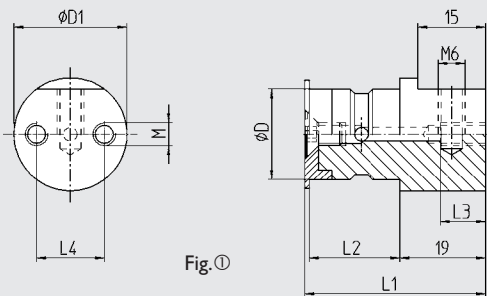
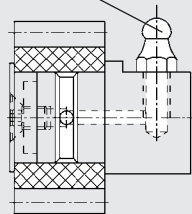

Fig. ①

Schmiernippel
Graisseur au huile
Lube nipple



Part. No.	L ₁	L ₂	D	M	L ₃	L ₄	D ₁	Filzritzel Pignon en feutre Felt pinion
230900	31	11	8	M 4	8	13	20	230800 230810
230901	33	13	12	M 4	8	13	20	230801 230811
230902	36	16	12	M 4	8	13	20	230802
230903	36	16	15	M 4	8	13	20	230820 230812
230904	41	21	15	M 4	8	13	20	230821
230905	41	21	20	M 5	10	15	25	230803 230813
230906	46	26	20	M 5	10	15	25	230822
230907	46	26	25	M 5	10	20	30	230814
230908	51.5	31	30	M 5	10	20	40	230804 230815 230823
230909	61.5	41	40	M 6	12	30	50	230805 230816 230824
230910	71.5	51	50	M 6	12	30	60	230806 230817 230825
230911	81.5	61	50	M 6	12	30	60	230807 230808 230818 230826 230827
230912	113	91	80	M 10	20	50	95	230819 230828

Für die automatische Versorgung mehrerer Schmierstellen kann ein komplettes Set mit Schmierstoffspender, Kolbenverteiler, Verschraubungen und Schlauchverbindungen bezogen werden.

Pour la lubrification centrale de plusieurs points de lubrification il est possible de commander un set complete qui se compose d'un distributeur lubrifiant, piston distributeur, boulonnage et tuyantrie en plastique.

For the automatic lubrication of several oiling points it is possible to order a complet set containing automatic lubricator, piston distributor, fittings and plastic tubes.

Schmierstoff / Lubrificant / Lubricant

Zahnstange/Ritzel ①

Crémaillère/Pignon

Rack/Pinon

Verzahnung ①

Denture

Gear teeth



Texaco



Mobil
Glygoyl 460

Degol
GS 460

BP Energol
SG-XP 460

Pinnacle
460

Tivela
S 460

Klübersynth
GH6-220

Mobilux
EP 2

Aralup
HLP 2

BP Energol
LS-EP 2

Multifak
EP 2

Alvania
EP-2

Centoplex
EP-2

Zahnstange montieren

Montage

Assembly

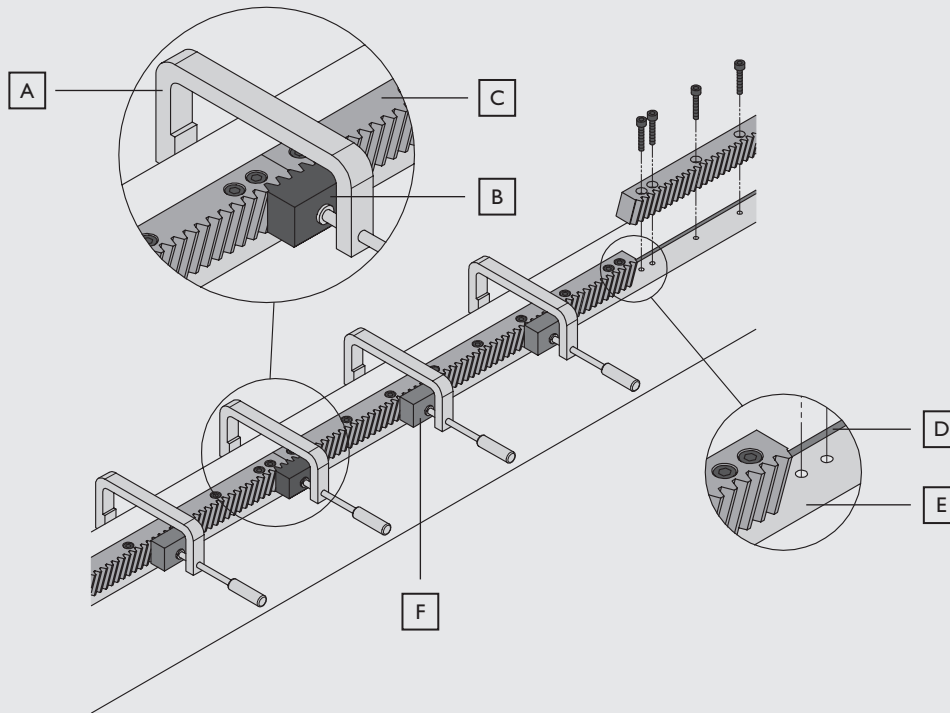

- A Schraubzwinge
- B Montagehilfe
- C Zahnstange
- D Anschlagsschulter
- E Basisfläche
- F Holzklötz

- A Serre-joint
- B Moyen d'assemblage
- C Crémaillère
- D Épaulement de butée
- E Surface de base
- F Cale en bois

- A Screw clamp
- B Mounting aid
- C Rack
- D Limit stop edge
- E Base surface
- F Wood block

Montieren Sie die Zahnstange wie folgt:

1. Basisfläche und Anschlagsschulter gründlich reinigen und mit Ölstein abziehen
 2. Zahnstange gründlich reinigen und mit Ölstein abziehen
 3. Zahnstange mit Schraubzwingen gegen Anschlagsschulter klemmen
 4. Alle Schrauben festziehen (Auf Höhe der fest zu ziehenden Schraube unbedingt Schraubzwinge anbringen)
 5. Zahnstangenübergang kontrollieren gemäss Abschnitt Zahnstangenübergang kontrollieren
 6. Bei Abweichung:
 - 6.1 Schrauben und Zahnstangen entfernen
 - 6.2 Vorgehen wiederholen
- Die Zahnstange ist montiert.

Monter la crémaillère de la manière suivante

1. Nettoyer soigneusement la surface de base et l'épaulement de butée, poncer avec la pierre à huile
 2. Nettoyer soigneusement la crémaillère, poncer avec la pierre à huile
 3. Bloquer la crémaillère contre l'épaulement de butée avec des serre-joints
 4. Serrer toutes les vis (positionner un serre-joint au niveau de la vis à serrer)
 5. Contrôler la jonction des crémaillères
 6. En cas de divergence:
 - 6.1 Déposer les vis et les crémaillères
 - 6.2 Répéter la procédure
- La crémaillère est montée

Install the racks as follows:

1. Clean the base surface and the shoulder thoroughly and rub an oil stone across them
 2. Clean the racks thoroughly and rub an oil stone across them
 3. Use the screw clamps to clamp the rack against the shoulder
 4. Tighten all screws (at the height of the to tightening screw has to be a screw clamp)
 5. Inspect rack transition according to Section Assembly Inspecting rack transition.
 6. If deviations occur:
 - 6.1 Remove screws and racks
 - 6.2 Repeat the procedure
- The rack is assembled.

Zahnstangenübergang kontrollieren

Contrôle de la jonction des crémaillères

Assembly Inspecting rack transition

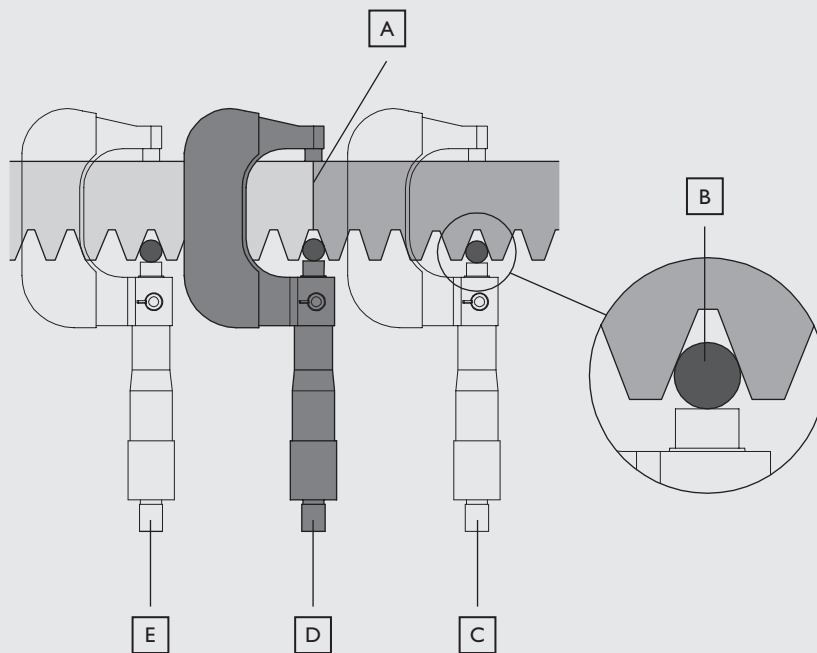

Diese Methode ist für gerad- und schrägverzahnte Zahnstangen geeignet

Cette méthode est adaptée aux crémaillères à denture droite ou oblique

This method will be used for straight- and helical-tooth racks

Zahnstangenübergang kontrollieren mit Messschraube

Contrôler la jonction des crémaillères avec un micromètre

Inspect rack transition with micrometer

- A Zahnstangenübergang
- B Messbolzen
- C Messschraube Position C
- D Messschraube Position D
- E Messschraube Position E

- A Jonction des crémaillères
- B Pige de mesure
- C Micromètre position C
- D Micromètre position D
- E Micromètre position E

- A Rack transition
- B Measurement bolt
- C Micrometer position C
- D Micrometer position D
- E Micrometer position E

Zahnstangenqualität Zulässige Abweichung [mm]

4	0.01
6	0.03
7	0.08
8	0.20
9	0.20

Qualité des crémaillères Divergence admise (mm)

4	0.01
6	0.03
7	0.08
8	0.20
9	0.20

Quality Permissible deviation [mm]

4	0.01
6	0.03
7	0.08
8	0.20
9	0.20

Einbau und Ausbau

Montage

Assembly

Montagehinweise

Damit unsere Normzahnstangen in beliebiger Länge montiert werden können, sind sie so verzahnt, dass Anfang und Ende jeweils eine halbe Zahnücke bilden. Fig. ① zeigt, wie die Zahnstangen in teilungsgenaue Position gebracht werden kann. Um einen möglichst sanften und geräuscharmen Übergang zu bewerkstelligen, empfehlen wir eine in die Gegenrichtung verzahnte Montagehilfe anzufordern.

Instruction pour le montage

Pour que les crémaillères puissent être rabou-tées aux longueurs désirées, la denture com-mence et se termine par un demi pas. La Fig. ① montre comment la crémaillère doit être mon-tée pour que les dernières dents soient en po-sition de pas précis. Pour le montage nous vous conseillons d'utiliser une crémaillère de mon-tage comme montré.

Mounting instruction for assembly

To make it possible to link our standard racks to form any desired length, the teeth are cut so that there is half a tooth gap at each end of the rack. The Fig. ① shows how rack 1 and rack 2 can be brought into the correct pitch position. Mounting aids with teeth cut in the opposite di-rection are available.

Fig. ①

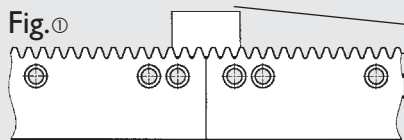

Gegenstück für Montage mit Verzahnung
Pièce de montage avec crémaillères
Companion part for assembly

Gerade verzahnt/Denture droite/Straight tooth

Part. No.	p	Modul
902410	3.142	1.0
902411	4.712	1.5
902412	6.283	2.0
902413	7.854	2.5
902414	9.425	3.0
902415	12.566	4.0
902416	15.708	5.0
902417	18.850	6.0
902418	25.133	8.0
902419	31.416	10.0

Gerade verzahnt/Denture droite/Straight tooth

Part. No.	p	Modul
902280	4.712	1.5
902281	6.283	2.0
902282	7.854	2.5
902283	9.425	3.0
902284	12.566	4.0
902285	15.708	5.0
902286	18.85	6.0
902287	25.133	8.0
902288	31.416	10.0

Gerade verzahnt/Denture droite/Straight tooth

Part. No.	p	Modul
902400	2.0	0.637
902401	5.0	1.592
902402	7.5	2.387
902403	10.0	3.183
902404	12.5	3.979
902405	16.0	5.093
902406	20.0	6.366
902407	25.0	7.958

Um optimale Anlage zu erzielen, empfehlen wir bei Zahnstangen mit Befestigungsbohrungen die Montage in Winkel-Profilleisten und Abbohren der Zahnstange. Dabei gilt zu beachten, dass die beiden Teilungslinien parallel sein müssen.

Die Zahnstangen haben einen Eckradius von 0.5 mm. Zum Befestigen der Zahnstange soll der Gegenradius maximal 0.2mm betragen. Ausnahme Zahnstangen Seiten 42,43,46,48 und 49 sind ohne Radius.

Afin d'obtenir une construction idéale, il est re-commandé de percer les poutres en utilisant les perçages des crémaillères comme modèles. Il faut prendre en considération que les deux cré-maillères doivent être parfaitement alignées.

Pour le montage correcte il est nécessaire de réaliser un rayon de dégagement suivant schéma. Les crémaillères ont un rayon de 0.2 mm. Sauf crémaillères page 42,43,46,48 et 49.

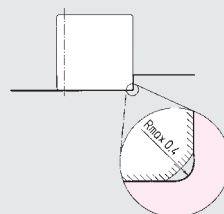

To ensure an optimal construction and smooth rolling conditions we recommend the assembly of racks with predrilled mounting holes in angle-profile sections and to copy the holes on as-sembly. Furthermore it is important, that the two pitch lines are set parallel.

For fitting the racks the opposite radius should not exceed 0.4 mm. The racks have a radius of 0.2 mm. Exemption racks on page 42,43,46,48 and 49.

Der Abstand zwischen dem Zentrum des Wel-lenritzel und dem Grund der Zahnstange (= Achsabstand a) ergibt sich nach:
Bei Zahnstangentreiben kann das Flankenspiel durch Beistellen eines der beiden Antriebs-elemente eingestellt werden.

La distance entre le centre du pignon et le bas de la crémaillère (= entraxe a) se calcule com-mes suit:
Pour ajuster le jeu primitif du système d'entraî-nement, il faut changer entraxe en dé-plaçant un des deux éléments d'entraîne-ment.

The distance between the center of the pinion and the bottom of the rack (= centre distance a) is calculated as follows.
For the adjustment of the backlash it is neces-sary to change the center distance either by moving the pinion or by moving the rack.

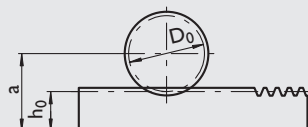

$$a = h_0 + \frac{D_0}{2}$$

Qualitätskontrolle

Um die hohen Qualitätsanforderungen unserer Kundschaft zu erfüllen, werden unsere Normzahnstangen auf modernsten Werkzeugmaschinen im eigenen Haus gefertigt. Für optimale Spieleinstellung und Laufruhe des Ritzels auf der Zahnstange wird ein dem Modul entsprechender Kopfkantenbruch gemacht. Als Bezugsprofil dient die Norm DIN 867. Die Qualitätskontrolle geschieht gemäss ISO 9001:2008 / OHSAS 18001:2007 als Erststück- und Stichprobenkontrolle. Die Zahnstangen werden auf einer modernen CNC-Messmaschine ausgemessen. All diese Einzelheiten garantieren unserer Kundschaft den Erwerb eines qualitativ hochwertigen Produktes.

Contrôle de qualité

Pour satisfaire les exigences élevées de notre clientèle, nos crémaillères sont fabriquées dans notre propre usine par des machine-outils ultra-modernes. Pour un fonctionnement silencieux ainsi que pour un réglage optimal du jeux pignon/crémaillère, nos crémaillères sont usinées avec un chanfrein spécifique à la tête du dent. Le profil de la denture est suivant la norme DIN 867. Le contrôle de qualité est fait suivant les exigences de la norme ISO 9001:2008 / OHSAS 18001:2007, appliqué pour le contrôle premier pièce de serie ainsi que pour les prélèvements durant la production. Les critères de qualité sont mesuré avec une machine de contrôle ultra-moderne. Tous ces efforts garantissent un produit de très haute qualité.

Quality control

To meet the high requirements of our clients, our racks and servo drives are manufactured in-house by help of ultra-modern machine tools. The racks have a specific tip radius to achieve minimal backlash as well as very smooth running. The profile is machined according DIN 867. Quality control is done according ISO 9001:2008 / OHSAS 18001:2007, applied for check of first piece of a serie as well as for sampling during production. Quality features are measured with a latest technology CNC-measuring machine. All these efforts guarantee a product of highest quality.



Impressum:
GÜDEL AG
Industrie Nord
4900 Langenthal
Switzerland

© by GÜDEL Juni 2010

Gestaltung und Satz:
Mario Rothenbühler
Jacqueline Uebelhart
Manu Wurch

Druck:
Digital Druckcenter Langenthal AG
4900 Langenthal
Switzerland

www.gudel.com

