



Leadscrew Assemblies

Overview of Leadscrew Assemblies



Haydon Kerk Motion Solutions, Inc. • www.haydonkerk.com • Phone: 800.243.2715 • International: 203.756.7441

LEADSCREW
TECHNOLOGIES

Haydon Kerk Motion Solutions products have been designed specifically for motion control applications. They are not compromised adaptations of general purpose screws or nuts. The screw thread form is designed for maximum life, quiet operation, and compatibility with Haydon Kerk Motion Solutions anti-backlash nut designs.

KERK® LEADSCREWS are available in standard diameters from 1/8-in (3.2mm) to 15/16-in (23mm), with standard leads from .012-in to almost 4-in (0.30mm to 92mm) including hard metric and left hand threads. Custom sizes and leads can be special ordered. Most stock screws are manufactured from 303 stainless steel and are produced with Haydon Kerk Motion Solutions exclusive precision rolling process. Other materials are available on special order. Positional bi-directional repeatability (with Kerk anti-backlash nut) is within 50 micro-inches (1.25 micron) and standard lead accuracy is better than 0.0006-in./in. (mm/mm). Lead accuracies are available to .0001-in./in. (mm/mm). Haydon Kerk Motion Solutions total in-house manufacturing and quality control assure uniform and consistent products.



KERK® NUTS are available in 8 standard anti-backlash designs (CMP, ZBX, WDG, NTB, KHD, VHD, NTG, ZBA); general purpose BFW Series plus the Mini Series. (See Product Comparison Chart for size availability). Custom nut configurations and mountings are also readily available. The Kerk brand anti-backlash designs provide assemblies which are wear compensating with low frictional drag and exceptional positional repeatability. Operation to more than 300 million inches of travel can be achieved. Haydon Kerk Motion Solutions provides nuts in a wide range of wear resistant, self-lubricating thermoplastic materials.



Axial Take-up Mechanism

The standard method for taking up backlash is to bias two nut halves axially using some type of compliant spring. (Wavy washer, compression spring, rubber washer, etc.)

The unit is very stiff in the direction in which the nut half is loaded against the flank of the screw thread. However, in the direction away from the screw thread, the nut is only as axially stiff as the amount of preload which the spring exerts.

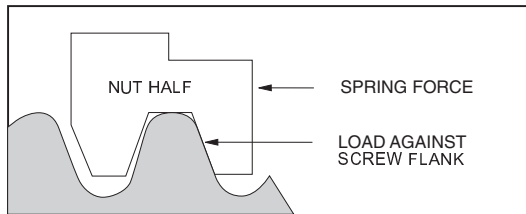
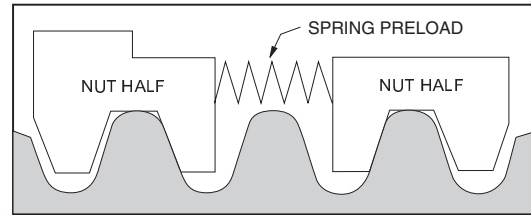

For example, if the maximum axial load to which the system is subjected is 50 lbs., the amount of spring preload must be equal to, or greater than, 50 lbs. in order to maintain intimate screw/nut contact. The problems arising from preloading in this manner are increased drag torque and nut wear.

Obviously, the higher the load at the screw/nut interface, the higher the required torque to drive the nut on the screw and the more susceptible the unit is to nut wear.

An alternate method replaces the spring with a stiff spacer sized to fit exactly between the two nut halves.

There is no excessive preload force at the interface and the unit is capable of carrying high axial loads in either direction with no backlash.

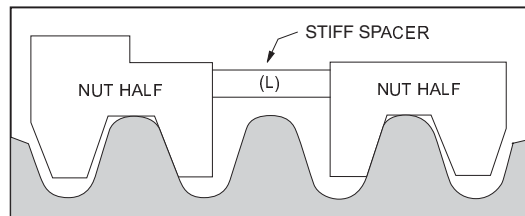

This is fine initially. However, as use time increases, wear begins on the nut threads causing a gap to develop between the spacer (L) and the nut halves.

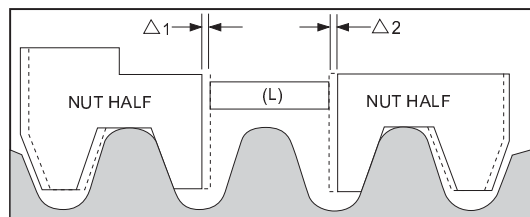

This gap ($\Delta 1 + \Delta 2$) is now the amount of backlash which has developed in the unit. This backlash can be removed by replacing the stiff spacer with a new spacer equal to $(L + \Delta 1 + \Delta 2)$. This process, although effective, would be extremely costly and difficult to implement on a continuous basis.

The Solution

What is needed, then, is a stiff spacer which will continually expand to accommodate the wear which occurs during use.

This is done by creating a spacer threaded at one end with a complimentary nut torsionally biased to advance when a gap develops.

The thread at the end of the spacer is a fine helix such that an axial load will not backdrive the nut once spacer growth has occurred.

The preload on the unit is only the amount necessary to turn the spacer nut on the spacer rod and is independent of the external system loadings. We thus have a self-wear compensating unit which has extremely low frictional drag torque yet high axial stiffness.

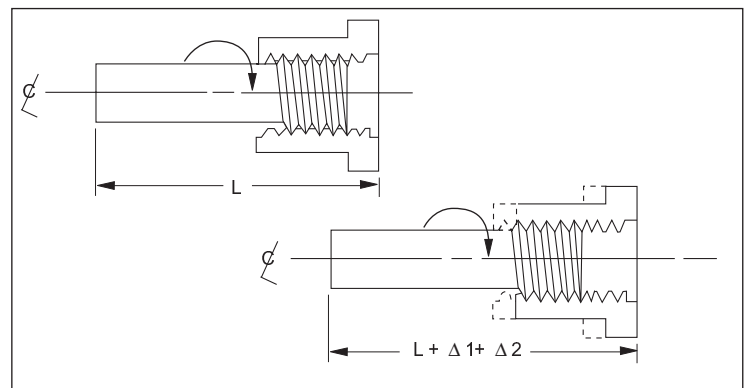



Kerkote® and Black Ice™ TFE Coatings

Haydon Kerk Motion Solutions, Inc. offers multiple options for lubrication. All Kerk® leadscrew nuts feature self-lubricating polymers. When maximum performance is required, Kerkote® and Black Ice™ TFE coatings provide unmatched results in the most demanding applications.

The purpose of TFE coating is to supply a more even distribution of lubricant than is normally found when using standard self-lubricating plastics on steel. The wear life, coefficient of friction and resulting torque to drive a lead screw assembly are highly governed by the ability of the engineered plastic to supply sufficient lubrication to the nut/screw interface. The inability of the internal lubricating agents in some plastics to consistently migrate to the surface may result in erratic drag torques and unpredictable wear.

Kerkote® TFE Coating

Kerkote TFE coating covering the entire screw surface results in an extremely even lubrication distribution. Test results indicate system torque requirements are consistently low with little or no change in required frictional driving torque, even with changes in motor R.P.M. Haydon Kerk Motion Solutions has developed a custom composition Kerkote TFE specifically for our lead screw and nut materials. It is applied using an automated process and provides extended nut life and smooth operation with little additional cost.

Kerkote TFE is a soft coating, a long-term dry lubricant that is optimized for softer plastics like acetals and nylons, with or without mechanical reinforcement. Lubrication to the nut/screw interface occurs by the nut picking up Kerkote TFE particles from the coating as well as from the migration of the internal lubricant within the plastic nut. Although care is taken to ensure that chips and voids do not occur in the coating, small voids have been shown to have no effect on system performance. The transfer of TFE to the nut continues throughout the operating life of the assembly as long as the nut periodically travels over areas with Kerkote TFE coating. The lubricant, although solid, also has some “spreading” ability as in fluid lubricants. Kerkote TFE coated screws provide the maximum level of self-lubrication and should not be additionally lubricated or used in environments where oils or other lubricant contamination is possible.

Black Ice™ TFE Coating

Black Ice TFE coating shares many of the benefits of Kerkote TFE but, in contrast, is a hard coating that offers exceptional durability in all types of environments, with virtually any type of polymer nut. Black Ice TFE coating remains on the screw, offering a low friction surface upon which the nut travels. Rather than acting as a dry lubricant, Black Ice TFE is an anti-friction coating whose surface properties displace the metal to which it is applied. Though it is not intended for use with metal or glass fiber reinforced nuts, Black Ice TFE is bonded securely to the screw’s surface and can withstand abrasion from contamination, rigid polymer systems, fluid impingement and wash down applications. Black Ice TFE can be used in the presence of more aggressive environment conditions, or anywhere reduced friction and a permanent coating is desired.

Both Kerkote and Black Ice TFE coatings offer the advantages of dry lubrication. These are maintenance-free coatings that are designed to last the life of the product. They are intended to be used without additional lubricants, thereby further increasing the value of Kerk leadscrew assemblies through elimination of the most common failure of screw driven drives, lubrication failure.

There are certain applications where external lubrication may be desired. These include the use of nut materials such as glass reinforced plastic or metal. Greases, when used properly can provide unique capabilities and Haydon Kerk Motion Solutions does offer a selection of greases developed specifically for these applications. Please contact a sales engineer for assistance selecting the best lubricant for your requirements.



303 Stainless Steel

Kerk® brand leadscrews and linear rails start with premium grade 303 stainless steel. Haydon Kerk Motion Solutions, Inc. has identified the material properties most critical for producing the very high quality rolled steel screws in the world and controls these to levels unmatched in the industry. Because of our leadership position, we are able to utilize this exceptional quality steel without having to charge premium prices.

Kerk stainless steel leadscrews and guide rails are corrosion resistant, non-magnetic, and compatible with many demanding processes. The ideal starting point for a maintenance-free product, this premium quality stainless steel is being used in numerous applications including medical applications, clean rooms, food and human contact, salt spray, cryogenics and vacuum.

Kerkite® Composite Polymers

In addition to the Kerk® self-lubricating acetal nut material, Haydon Kerk Motion Solutions offers a variety of custom compounded Kerkite composite polymers. Kerkite polymers are a family of high performance materials that offer exceptional wear properties with the cost and design advantages afforded through injection molding. Kerkite polymers offer a variety of mechanical, thermal and electrical properties and are compatible with many chemicals and environmental conditions.

Kerkite Composite Polymers are available options for most Kerk Leadscrew Nuts and are standard materials for Linear Rail and Spline Shaft bushings, RGS® Carriages and Screwrail® Bushings and End Supports. Each member of the Kerkite family is compounded with lubricants, reinforcements and thermoplastic polymers formulated to provide optimum performance in its target conditions and applications, resulting in superior performance and extended life.

A cornerstone of the Haydon Kerk Motion Solutions advantage is design flexibility. Kerkite Composite Polymers, along with our injection molding and mold making capabilities, offer huge design advantages and cost savings compared with non-moldable materials. Kerkite high performance polymers outperform other plastics and outlast metal bushings and bearings. When combined with Kerkote® or Black Ice™ TFE coatings, Kerkite Composite Polymers have been shown to provide hundreds of millions of inches of travel in customer applications while continuing to maintain precise, accurate motion and positioning.

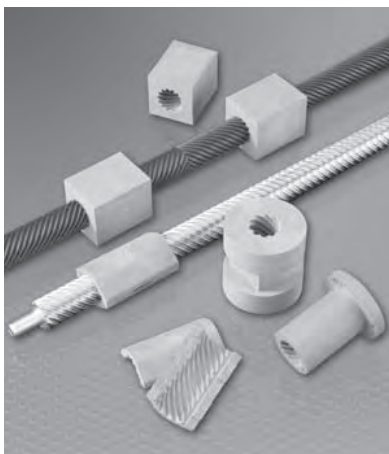

Special Materials

In addition to the Kerk standard material – 303 stainless steel, self lubricating acetal and Kerkite high performance composite polymers – we also work with a vast array of custom materials. Kerk has rolled screws in many other materials, including 316 stainless, 400 series stainless, precipitate hardening materials, carbon steel, aluminum, and titanium. Kerk nuts had been produced in many alternative plastics including PEEK, polyester, Torlon®, Vespel®, PVDF, UHMW, Ertalyte® and customer-supplied specialty materials. We have also provided metal nuts made from bronze, brass, and stainless steel.

With so much flexibility in our manufacturing process, if the material can be molded, machined, ground, or rolled, Haydon Kerk Motion Solutions can likely process it using state of the art machine tools, injection molding and mold making, grinding and thread rolling equipment. Haydon Kerk Motion Solutions excels at supplying the best overall solution to meet our customers' requirements. Contact Haydon Kerk Motion Solutions to find out how you can benefit from these choices.

Design and Engineering Data

Screw Accuracy

Haydon Kerk Motion Solutions, Inc uses a unique precision rolling process for screw manufacturing. Standard lead accuracy for Kerk screws is .0006 in./in. (mm/mm). Lead accuracies are available up to .0001 in./in. (mm/mm). Please consult the factory for higher lead accuracies. Assemblies have an extremely high bi-directional repeatability of 50 micro-inches (1.25 micron).

End Machining

Haydon Kerk Motion Solutions can custom machine screws to your specifications or provide cut-to-length screws for your own machining.

Critical Speed

This is the rotational speed at which a screw may experience vibration or other dynamic problems. See CRITICAL SPEED CHART to determine if application parameters result in speed approaching critical. To minimize critical speed problems: use a longer lead, choose a larger diameter or increase bearing mount support.

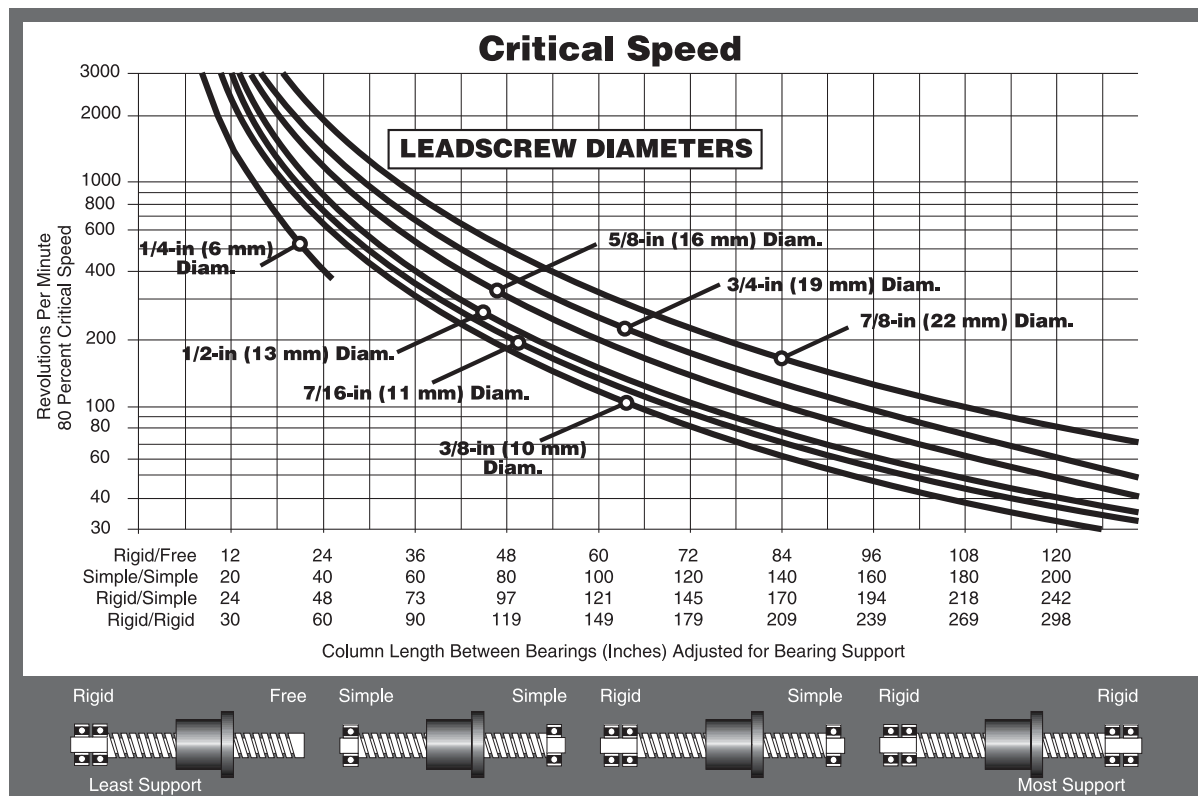

Lengths

Lengths can be specified up to 12 ft. (4M) from stock, (depending on diameter and lead). Cut to length screws are offered in 6-in increments (6-in, 12, 18,...) +1.0-in/-0-in.

Lead

Advancement per revolution. All screws are listed by lead, not pitch.

Lead = Pitch x Number of Starts

Pitch

Crest-to-crest distance or one divided by threads per inch. (On a multiple start thread, the pitch equals the lead divided by the number of starts.)

Traverse Speed

The nut materials we use provide long wear-life over a wide variety of conditions. However, very high loads and/or speeds will accelerate nut wear. Special materials may be required for these situations. We offer the following guidelines for continuous duty linear traversing speeds for optimum life:

Lead	Traverse Speed	Lead	Traverse Speed
1/10 - 1/2-in	4-in/sec.	1 - 12 mm	100 mm/sec.
1/2 - 1-in	10-in/sec.	12 - 25 mm	250 mm/sec.
1 - 2 1/2-in	30-in/sec.	25 - 60 mm	760 mm/sec.

Maximum Load

Although the Kerk® Anti-Backlash Assemblies are capable of withstanding relatively high loads without catastrophic failure, these units have been designed to operate under the loading shown in the size charts.

Efficiency

Efficiency is the relationship of work input to work output. It should not be confused with mechanical advantage. Listed efficiencies are theoretical values based on Kerkote® TFE coated screws.

Torque

The required motor torque to drive a lead screw assembly is the sum of three components: the **inertial torque**, **drag torque**, and **torque-to-move load**. It must be noted that this is the torque necessary to drive the lead screw assembly alone. Additional torque associated with driving frictional bearings and motor shafts, moving components, and drag due to general assembly misalignment must also be considered.

Inertial Torque:

$$T_j = I \alpha \quad \text{Where } I = \text{screw inertia} \\ \alpha = \text{angular acceleration}$$

Drag Torque:

The Kerk Anti-Backlash Assemblies are typically supplied with drag torque of 1 to 7 oz.-in. The magnitude of the drag torque is dependent on the standard factory settings or settings specified by the customer. Generally, the higher the preset force, the better the Anti-Backlash characteristics.

Torque-to-Move:

$$T_L = \frac{\text{LOAD} \times \text{LEAD}}{2\pi \times \text{EFFICIENCY}}$$

Back Driving

Sometimes referred to as reversibility, back driving is the ability of a screw to be turned by a thrust load applied to the nut. Generally, back driving will not occur when the screw lead is less than 1/3 the diameter for uncoated screws or 1/4 the diameter for Kerkote® TFE coated screws. For higher leads where back driving is likely, the torque required for holding a load is:

$$T_b = \frac{\text{LOAD} \times \text{LEAD} \times \text{BACKDRIVE EFFICIENCY}}{2\pi}$$

Screw Straightness

Screw straightness is measured as Total Indicator Runout(TIR). The standard straightness for lead screws is .003-in/ft. Haydon Kerk Motion Solutions can provide tighter specifications on customer request.

All screws are hand straightened before shipping.

Mechanical Properties

Screw Inertia

Screw Size inch (mm)	Screw Inertia (oz-inch sec ² /inch)
5/64 (2)	3.4 x 10 ⁻⁸
1/8 (3.2)	1.8 x 10 ⁻⁷
9/64 (3.5)	3.4 x 10 ⁻⁷
5/32 (3.97)	4.9 x 10 ⁻⁷
3/16 (4.76)	1.1 x 10 ⁻⁶
7/32 (5.55)	1.8 x 10 ⁻⁶
1/4 (6)	.3 x 10 ⁻⁵
5/16 (8)	5 x 10 ⁻⁵
3/8 (10)	1.5 x 10 ⁻⁵
7/16 (11)	3.5 x 10 ⁻⁵
1/2 (13)	5.2 x 10 ⁻⁵
5/8 (16)	14.2 x 10 ⁻⁵
3/4 (19)	30.5 x 10 ⁻⁵
7/8 (22)	58.0 x 10 ⁻⁵
15/16 (24)	73.0 x 10 ⁻⁵

Dimensional Tolerances

Inch		Metric	
.X	± .02	< L 4	± 0.1
.XX	± .010	4 < L ≤ 16	± 0.15
.XXX	± .005	16 < L ≤ 63	± 0.2
		63 < L ≤ 250	± 0.3

Grease Compatibility Chart

Nut Type	Lubrication Coatings		
	Grease	Kerkote®	Black Ice™
CMP	Yes	Yes	Yes
ZBX	Yes	Yes	Yes
ZBA	Yes	Yes	Yes
KHD	No	Yes	Yes
VHD	No	Yes	Yes
WDG	No	Yes	Yes
BFW	Yes	Yes	Yes
NTB	No	Yes	Yes
NTG	Yes	Yes	Yes

Anti-Backlash Life

Series	Without Kerkote® TFE Coating inch (cm)	With Kerkote® TFE Coating inch (cm)
CMP	40 to 60 million (100 to 150 million)	150 to 200 million (380 to 500 million)
ZBA	5 to 10 million (12 to 25 million)	15 to 40 million (38 to 100 million)
ZBX	40 to 60 million (100 to 150 million)	150 to 200 million (380 to 500 million)
KHD	80 to 100 million (200 to 250 million)	180 to 230 million (450 to 580 million)
WDG	100 to 125 million (250 to 315 million)	200 to 250 million (500 to 635 million)
NTB	100 to 125 million (250 to 315 million)	200 to 250 million (500 to 635 million)
VHD	200 to 225 million (500 to 570 million)	300 to 350 million (760 to 880 million)
BFW	N/A, Typical Backlash .003 to .010 (.076 to .25)	N/A, Typical Backlash .003 to .010 (.076 to .25)
NTG	5 to 10 million (12 to 25 million)	15 to 40 million (38 to 100 million)

Anti-backlash life is defined as the nut's ability to compensate for wear while maintaining its zero backlash properties. Above life data is based on 25% of the dynamic load rating. NTB style does not include mini series sizes. Life will vary with loading, operating environment, and duty cycle. The longer screw leads generally provide longer life.

Mechanical Properties

Leadscrew

Material	Surface Finish
303 Stainless Steel (options available)	Better than 16 micro inch

Nuts

Material	Tensile Strength	Coefficient of Expansion
Polyacetal with Lubricating Additive	9,700 psi	6.0 x 10 ⁻⁵ in/in/°F

Assembly

Standard Operating Temp. Range	Coefficient of Friction Nut to Screw
32 - 200° F* (0 - 93° C)*	Static = .08 .08 ** Dynamic = .15 .09 **

* Very high or low temperatures may cause significant changes in the nut fit or drag torque. Please call Haydon Kerk Motion Solutions™ for optional temperature range materials.

** with Kerkote® TFE Coating



Kerk® Leadscrews

KERK® LEADSCREWS are available in standard diameters from 1/8-in (3.2mm) to 15/16-in (23mm), with standard leads from .012-in to almost 4-in (0.30mm to 92mm) including metric and left hand threads. Custom sizes and leads can be special ordered. Most stock screws are manufactured from 303 stainless steel and are produced with Haydon Kerk Motion Solutions exclusive precision rolling process. Other materials are available on special order. Positional bi-directional repeatability (with Kerk anti-backlash nut) is within 50 micro-inches (1.25 micron) and standard lead accuracy is better than 0.0006-in./in. (mm/mm). Lead accuracies are available to .0001-in./in. (mm/mm). Please consult factory for more details. Haydon Kerk Motion Solutions total in-house manufacturing and quality control assure uniform and consistent products.

LEADSCREW ASSEMBLIES

Identifying the part number codes when ordering

ZBX	F	K	R	-	012	-	0012	-	XXXX
Prefix:	Nut Mounting Style	Lubrication	Thread Direction		Diameter Code		Nominal Thread Lead Code		Unique Identifier
LSS (Screw Only)	A = Flanged (Triangular) F = Flanged (Round) P = Flange (Triangular with pilot) T = Threaded S = Screw only	S = Uncoated K = Kerkote® TFE Coating G = Grease HSS-17 Standard N = Nut only	R = Right hand L = Left hand (Refer to lead-screw charts for availability)		(Refer to leadscrew charts)		(Refer to leadscrew charts)		Number assigned by Haydon Kerk Motion Solutions (including length and other added features such as end machining, custom configurations, etc.)
Nut Series	For Micro Nuts Only: B = Barrel R = Rectangular								
CMP ZBX WDG NTB KHD VHD NTG ZBA BFW									

EXAMPLES:

LSSSSR-025-0250 = Leadscrew only, uncoated, right hand thread, 1/4-in nominal screw diameter, 0.250 thread lead, without an assigned unique identifier

WDGABR-037-0125-XXXX = Assembly: WDG Series Nut, triangular flanged mount, Black Ice™ TFE coating, right hand thread, 3/8-in nominal screw diameter, 0.125 thread lead, without an assigned unique identifier

ZBXTKR-043-0250-XXXX = Assembly: ZBX Series Nut, thread mounting, Kerkote® TFE coating, right hand thread, 7/16-in nominal screw diameter, 0.250 thread lead, without an assigned unique identifier

Special environments (temperature, clean room, contaminants, etc.)

For applications assistance or order entry, call your the Haydon Kerk Motion Solutions Leadscrew Assemblies technical advisors at 603.465.7227.

NOTE:

- Not all thread leads are available in all screw diameters
- New nuts and leads are continually being added. Contact Haydon Kerk Motion Solutions for latest availability.

Leadscrews: Leadscrew Size List



Haydon Kerk Motion Solutions, Inc. • www.HaydonKerk.com • Phone: 800.243.2715 • International: 203.756.7441

Leadscrew Size List

LEADSCREW ASSEMBLIES

Diameter (inches) (mm)	Diameter Code	Lead (inches) (mm)	LEAD CODE	Left Hand Available	Outside Diameter (for Reference) (inches) (mm)	Root Diameter (for Reference) (inches) (mm)	Efficiency %*	Compatible Nut Styles	
5/64	2	008	0.012 0.30	0012		0.079 2.01	0.068 1.73	24**	BFW
			0.016 0.40	0016		0.075 1.91	0.058 1.47	30**	
			0.020 0.50	0020		0.077 1.96	0.057 1.45	36**	
			0.039 1.00	0039		0.079 2.01	0.059 1.50	52**	
			0.079 2.00	0079		0.077 1.96	0.057 1.45	66**	
1/8	3.2	012	0.024 0.61	0024		0.129 3.28	0.093 2.36	44	NTB NTG BFW
			0.039 1.00	0039		0.129 3.28	0.094 2.39	57	
			0.048 1.22	0048		0.129 3.28	0.093 2.36	61	
			0.075 1.91	0075		0.129 3.28	0.093 2.36	70	
			0.096 2.44	0096	●	0.129 3.28	0.093 2.36	75	
			0.125 3.18	0125	LH Only	0.125 3.18	0.078 1.98	80	
0.132	3.3	013	0.020 0.50	0020		0.132 3.35	0.104 2.64	42	NTB NTG BFW
			0.039 1.00	0039		0.132 3.35	0.080 2.03	61	
			0.079 2.00	0079		0.132 3.35	0.080 2.03	75	
			0.157 4.00	0157		0.132 3.35	0.080 2.03	84	
			0.315 8.00	0315		0.132 3.35	0.080 2.03	87	
9/64	3.6	014	0.012 0.30	0012		0.140 3.56	0.123 3.12	26	NTB NTG BFW
			0.024 0.61	0024		0.140 3.56	0.105 2.67	43	
			0.048 1.22	0048		0.140 3.56	0.081 2.06	62	
			0.096 2.44	0096		0.140 3.56	0.081 2.06	75	
			0.394 10.00	0394		0.140 3.56	0.102 2.59	86	
5/32	4	016	0.033 0.84	0033	●	0.156 3.96	0.116 2.95	45	NTB NTG BFW
			0.050 1.27	0050	LH Only	0.156 3.96	0.096 2.44	59	
			0.094 2.39	0094		0.164 4.17	0.128 3.25	67	
			0.125 3.18	0125		0.168 4.27	0.130 3.30	74	
			0.250 6.35	0250		0.156 3.96	0.130 3.30	83	
			0.375 9.53	0375		0.156 3.96	0.130 3.30	85	
			0.500 12.70	0500		0.156 3.96	0.130 3.30	86	
3/16	5	018	0.020 0.50	0020		0.188 4.78	0.163 4.14	30	CMP WDG NTB NTG BFW
			0.025 0.64	0025		0.188 4.78	0.150 3.81	39	
			0.039 1.00	0039		0.188 4.78	0.144 3.66	47	
			0.050 1.27	0050		0.188 4.78	0.124 3.15	58	
			0.100 2.54	0100		0.188 4.78	0.136 3.45	69	
			0.1875 4.76	0188		0.188 4.78	0.167 4.24	78	
			0.200 5.08	0200		0.188 4.78	0.124 3.15	82	
			0.375 9.53	0375		0.188 4.78	0.161 4.09	84	
			0.400 10.16	0400		0.188 4.78	0.124 3.15	84	
			0.427 10.85	0427		0.188 4.78	0.162 4.11	85	
			0.500 12.70	0500	●	0.188 4.78	0.142 3.61	86	
7/32	5.6	021	0.024 0.61	0024		0.218 5.54	0.181 4.60	31	WDG NTB NTG BFW
			0.03125 0.79	0031		0.204 5.18	0.160 4.06	39	
			0.048 1.22	0048		0.216 5.49	0.156 3.96	50	
			0.050 1.27	0050		0.200 5.08	0.135 3.43	52	
			0.0625 1.59	0063		0.218 5.54	0.142 3.61	60	
			0.096 2.44	0096		0.218 5.54	0.156 3.96	66	
			0.192 4.88	0192		0.218 5.54	0.156 3.96	78	
			0.250 6.35	0250	●	0.204 5.18	0.140 3.56	81	
			0.384 9.75	0384		0.218 5.54	0.159 4.04	86	

Shaded areas have been translated from their designed inch or mm dimension to an equivalent mm or inch dimension.

* Listed efficiencies are theoretical values based on Kerkote® TFE coated leadscrews

** Listed efficiencies for Micro screws are theoretical values based on non-coated leadscrews

Leadscrew Size List

Diameter (inches) (mm)	Diameter Code	Lead (inches) (mm)	LEAD CODE	Left Hand Available	Outside Diameter (for Reference) (inches) (mm)	Root Diameter (for Reference) (inches) (mm)	Efficiency %*	Compatible Nut Styles				
1/4	6	025	0.024	0.61	0024		0.250	6.35	0.218	5.54	28	CMP ZBX ZBA WDG NTB NTG BFW
			0.025	0.64	0025		0.250	6.35	0.214	5.44	30	
			0.03125	0.79	0031		0.250	6.35	0.208	5.28	34	
			0.039	1.00	0039		0.250	6.35	0.190	4.83	40	
			0.048	1.22	0048		0.250	6.35	0.190	4.83	45	
			0.050	1.27	0050	●	0.250	6.35	0.191	4.85	46	
			0.059	1.50	0059		0.250	6.35	0.172	4.37	52	
			0.0625	1.59	0063		0.250	6.35	0.170	4.32	52	
			0.079	2.00	0079		0.250	6.35	0.170	4.32	59	
			0.096	2.44	0096		0.250	6.35	0.190	4.83	61	
			0.100	2.54	0100		0.250	6.35	0.190	4.83	62	
			0.118	3.00	0118		0.250	6.35	0.175	4.45	68	
			0.125	3.18	0125		0.250	6.35	0.190	4.83	67	
			0.197	5.00	0197		0.250	6.35	0.172	4.37	72	
			0.200	5.08	0200		0.250	6.35	0.170	4.32	65	
			0.250	6.35	0250	●	0.250	6.35	0.168	4.27	79	
			0.3125	7.94	0313		0.250	6.35	0.184	4.67	81	
			0.333	8.46	0333		0.250	6.35	0.170	4.32	82	
0.394	10.00	0394		0.250	6.35	0.170	4.32	78				
0.400	10.16	0400		0.250	6.35	0.170	4.32	84				
0.500	12.70	0500	●	0.250	6.35	0.169	4.29	85				
0.750	19.05	0750		0.250	6.35	0.170	4.32	86				
1.000	25.40	1000	●	0.250	6.35	0.170	4.32	84				
5/16	8	031	0.057	1.44	0057		0.315	8.00	0.243	6.17	43	CMP ZBX ZBA KHD WDG NTB NTG BFW
			0.0741	1.88	0074		0.312	7.92	0.211	5.36	51	
			0.111	2.82	0111		0.312	7.92	0.232	5.89	60	
			0.167	4.24	0167		0.312	7.92	0.211	5.36	69	
			0.250	6.35	0250		0.312	7.92	0.234	5.94	76	
			0.500	12.70	0500		0.312	7.92	0.232	5.89	83	
			0.800	20.32	0800		0.306	7.77	0.243	6.17	86	

Shaded areas have been translated from their designed inch or mm dimension to an equivalent mm or inch dimension.

*Listed efficiencies are theoretical values based on Kerkote® TFE coated leadscrews



LEADSCREW
ASSEMBLIES

Leadscrews: Leadscrew Size List



Haydon Kerk Motion Solutions, Inc. • www.HaydonKerk.com • Phone: 800.243.2715 • International: 203.756.7441

Leadscrew Size List

Diameter (inches) (mm)	Diameter Code	Lead (inches) (mm)	LEAD CODE	Left Hand Available	Outside Diameter (for Reference) (inches) (mm)	Root Diameter (for Reference) (inches) (mm)	Efficiency %*	Compatible Nut Styles
---------------------------	------------------	-----------------------	--------------	---------------------------	--	---	------------------	-----------------------------

LEADSCREW
ASSEMBLIES

3/8	10	037	0.025	0.64	0025		0.375	9.53	0.337	8.56	21	CMP ZBX ZBA KHD WDG NTB NTG BFW
			0.039	1.00	0039		0.394	10.01	0.350	8.89	28	
			0.04167	1.06	0042		0.375	9.53	0.320	8.13	34	
			0.050	1.27	0050	●	0.375	9.53	0.301	7.65	36	
			0.055	1.40	0055		0.375	9.53	0.303	7.70	38	
			0.059	1.50	0059	●	0.389	9.88	0.313	7.95	38	
			0.0625	1.59	0063	●	0.375	9.53	0.295	7.49	41	
			0.068	1.73	0068		0.388	9.86	0.295	7.49	42	
			0.079	2.00	0079		0.375	9.53	0.264	6.71	47	
			0.0833	2.12	0083		0.375	9.53	0.293	7.44	48	
			0.100	2.54	0100	●	0.375	9.53	0.266	6.76	53	
			0.125	3.18	0125		0.375	9.53	0.295	7.49	59	
			0.157	4.00	0157		0.375	9.53	0.274	6.96	65	
			0.1667	4.23	0167		0.371	9.42	0.261	6.63	61	
			0.197	5.00	0197		0.375	9.53	0.266	6.76	69	
			0.200	5.08	0200	●	0.375	9.53	0.266	6.76	69	
			0.250	6.35	0250		0.375	9.53	0.268	6.81	70	
			0.300	7.62	0300		0.375	9.53	0.255	6.48	76	
			0.333	8.46	0333		0.375	9.53	0.245	6.22	78	
			0.363	9.22	0363	●	0.375	9.53	0.260	6.60	79	
			0.375	9.53	0375		0.375	9.53	0.265	6.73	79	
			0.394	10.00	0394		0.375	9.53	0.260	6.60	79	
			0.400	10.16	0400		0.375	9.53	0.293	7.44	79	
			0.472	12.00	0472		0.388	9.86	0.287	7.29	82	
			0.500	12.70	0500	●	0.388	9.86	0.265	6.73	81	
			0.667	16.94	0667		0.375	9.53	0.273	6.93	83	
0.750	19.05	0750		0.388	9.86	0.273	6.93	84				
0.984	25.00	0984		0.375	9.53	0.262	6.65	84				
1.000	25.40	1000		0.383	9.73	0.254	6.45	84				
1.200	30.48	1200	●	0.383	9.73	0.254	6.45	84				
1.250	31.75	1250		0.375	9.53	0.278	7.06	84				
1.500	38.10	1500		0.375	9.53	0.264	6.71	83				

7/16	11	043	0.050	1.27	0050		0.437	11.10	0.362	9.19	30	ZBX ZBA WDG NTB BFW
			0.0625	1.59	0063	●	0.436	11.07	0.358	9.09	38	
			0.079	2.00	0079		0.472	11.99	0.374	9.50	42	
			0.111	2.82	0111		0.437	11.10	0.327	8.31	52	
			0.118	3.00	0118		0.438	11.13	0.363	9.22	52	
			0.125	3.18	0125		0.438	11.13	0.357	9.07	54	
			0.197	5.00	0197		0.438	11.13	0.315	8.00	65	
			0.236	6.00	0236		0.433	11.00	0.313	7.95	70	
			0.250	6.35	0250		0.442	11.23	0.325	8.26	70	
			0.307	7.80	0307		0.445	11.30	0.343	8.71	73	
			0.325	8.26	0325		0.444	11.28	0.342	8.69	74	
			0.394	10.00	0394		0.446	11.33	0.331	8.41	78	
			0.463	11.76	0463		0.444	11.28	0.343	8.71	79	
			0.472	12.00	0472		0.438	11.13	0.318	8.08	80	
			0.500	12.70	0500		0.452	11.48	0.327	8.31	80	
			0.615	15.62	0615		0.475	12.07	0.376	9.55	82	

Shaded areas have been translated from their designed inch or mm dimension to an equivalent mm or inch dimension.

*Listed efficiencies are theoretical values based on Kerkote® TFE coated leadscrews

Leadscrew Size List

Diameter (inches) (mm)	Diameter Code	Lead (inches) (mm)	LEAD CODE	Left Hand Available	Outside Diameter (for Reference)		Root Diameter (for Reference)		Efficiency %*	Compatible Nut Styles		
					(inches)	(mm)	(inches)	(mm)				
1/2	13	050	0.050	1.27	0050		0.495	12.57	0.433	11.00	29	ZBX ZBA WDG NTB VHD BFW
			0.079	2.00	0079		0.473	12.01	0.355	9.02	41	
			0.098	2.50	0098		0.500	12.70	0.383	9.73	46	
			0.100	2.54	0100	●	0.490	12.45	0.364	9.25	46	
			0.125	3.18	0125		0.500	12.70	0.374	9.50	51	
			0.157	4.00	0157		0.500	12.70	0.384	9.75	58	
			0.160	4.06	0160		0.500	12.70	0.388	9.86	67	
			0.1667	4.23	0167		0.500	12.70	0.384	9.75	58	
			0.197	5.00	0197		0.500	12.70	0.365	9.27	62	
			0.200	5.08	0200	●	0.492	12.50	0.366	9.30	63	
			0.250	6.35	0250		0.500	12.70	0.382	9.70	67	
			0.333	8.46	0333	●	0.497	12.62	0.362	9.19	73	
			0.394	10.00	0394		0.497	12.62	0.362	9.19	76	
			0.400	10.16	0400		0.497	12.62	0.364	9.25	76	
			0.500	12.70	0500		0.488	12.40	0.352	8.94	79	
			0.630	16.00	0630		0.500	12.70	0.374	9.50	80	
			0.750	19.05	0750		0.525	13.34	0.399	10.13	83	
			0.800	20.32	0800		0.500	12.70	0.370	9.40	83	
0.984	25.00	0984		0.500	12.70	0.369	9.37	84				
1.000	25.40	1000	●	0.490	12.45	0.372	9.45	84				
1.500	38.10	1500		0.490	12.45	0.374	9.50	85				
2.000	50.80	2000		0.488	12.40	0.378	9.60	87				
5/8	16	062	0.100	2.54	0100		0.615	15.62	0.498	12.65	40	ZBX ZBA NTB VHD BFW
			0.125	3.18	0125	●	0.625	15.88	0.470	11.94	45	
			0.200	5.08	0200		0.625	15.88	0.495	12.57	53	
			0.250	6.35	0250		0.625	15.88	0.469	11.91	63	
			0.315	8.00	0315		0.627	15.93	0.493	12.52	68	
			0.500	12.70	0500	●	0.625	15.88	0.478	12.14	76	
			0.630	16.00	0630		0.625	15.88	0.491	12.47	78	
			1.000	25.40	1000		0.625	15.88	0.481	12.22	83	
			1.500	38.10	1500		0.625	15.88	0.499	12.67	85	
2.000	50.80	2000	●	0.625	15.88	0.499	12.67	86				

Shaded areas have been translated from their designed inch or mm dimension to an equivalent mm or inch dimension.

*Listed efficiencies are theoretical values based on Kerkote® TFE coated leadscrews

Leadscrews: Leadscrew Size List



Haydon Kerk Motion Solutions, Inc. • www.HaydonKerk.com • Phone: 800.243.2715 • International: 203.756.7441

Leadscrew Size List

Diameter (inches) (mm)	Diameter Code	Lead (inches) (mm)		LEAD CODE	Left Hand Available	Outside Diameter (for Reference) (inches) (mm)		Root Diameter (for Reference) (inches) (mm)		Efficiency %*	Compatible Nut Styles	
3/4	19	075	0.0625	1.59	0063		0.750	19.05	0.671	17.04	25	ZBA NTB VHD BFW
			0.098	2.50	0098		0.742	18.85	0.626	15.90	35	
			0.100	2.54	0100	●	0.746	18.95	0.624	15.85	35	
			0.1667	4.23	0167		0.727	18.47	0.645	16.38	47	
			0.197	5.00	0197		0.745	18.92	0.624	15.85	51	
			0.200	5.08	0200		0.741	18.82	0.632	16.05	52	
			0.250	6.35	0250		0.731	18.57	0.639	16.23	57	
			0.276	7.00	0276		0.750	19.05	0.624	15.85	59	
			0.333	8.46	0333		0.750	19.05	0.624	15.85	64	
			0.394	10.00	0394		0.745	18.92	0.619	15.72	68	
			0.500	12.70	0500		0.744	18.90	0.623	15.82	73	
			0.551	14.00	0551		0.750	19.05	0.624	15.85	73	
			0.591	15.00	0591		0.749	19.02	0.623	15.82	74	
			0.709	18.00	0709		0.780	19.81	0.650	16.51	77	
			0.748	19.00	0748		0.672	17.07	0.547	13.89	80	
			0.787	20.00	0787		0.780	19.81	0.648	16.46	78	
			0.800	20.32	0800		0.750	19.05	0.618	15.70	79	
			0.945	24.00	0945		0.734	18.64	0.633	16.08	80	
			1.000	25.40	1000	●	0.743	18.87	0.619	15.72	81	
			1.500	38.10	1500	●	0.712	18.08	0.590	14.99	84	
1.969	50.00	1969		0.751	19.08	0.620	15.75	84				
2.000	50.80	2000	●	0.742	18.85	0.611	15.52	84				
2.400	60.96	2400	●	0.750	19.05	0.620	15.75	84				
3.622	92.00	3622	●	0.750	19.05	0.634	16.10	87				
7/8	22	087	0.200	5.08	0200	●	0.870	22.10	0.742	18.85	48	ZBA NTB VHD BFW
			0.236	6.00	0236		0.848	21.54	0.773	19.63	52	
			0.250	6.35	0250		0.875	22.23	0.749	19.02	53	
			0.394	10.00	0394		0.875	22.23	0.741	18.82	65	
			0.500	12.70	0500		0.862	21.89	0.744	18.90	69	
			0.630	16.00	0630		0.875	22.23	0.741	18.82	73	
			0.667	16.94	0667		0.871	22.12	0.745	18.92	74	
			0.787	20.00	0787		0.875	22.23	0.741	18.82	78	
			0.945	24.00	0945		0.875	22.23	0.741	18.82	79	
			1.000	25.40	1000		0.871	22.12	0.742	18.85	80	
15/16	24	093	0.050	1.27	0050	LH Only	0.938	23.83	0.874	22.20	17	ZBA NTB BFW
			2.000	50.80	2000		0.927	23.55	0.815	20.70	85	
			3.000	76.20	3000	●	0.939	23.85	0.803	20.40	86	

Shaded areas have been translated from their designed inch or mm dimension to an equivalent mm or inch dimension.

*Listed efficiencies are theoretical values based on Kerkote® TFE coated leadscrews



Immediate availability of a standard selection of parts.

**Anti-Backlash:
Self-Compensating, Zero Backlash**



CMP Series
– Light Loads, Compact Design
Exceptionally compact self-lubricating acetal nut; ideally suited for applications using oil or grease.



ZBX Series
– Light Loads
Patented self-lubricating polyacetal nut; precise positional accuracy and repeatability at a low cost.



WDG Series
– Moderate Loads
An exceptionally compact design to provide stiffness and balanced accuracy for precise positioning. A self-lubricating acetal nut, axially preloaded, the patented wedge design locks the nut at the correct preload without excessive drag.



KHD Series
– Moderate Loads, Low Drag Torque
For moderate load applications; delivers increased load capacity and greater axial stiffness with low drag torque.



NTB Series
– Full Range, Flexible Design
Self-compensating nut assembly maintains axial stiffness throughout its life with minimum system drag torque. Easily modified for custom applications.



VHD Series
– Heavy Loads, High Axial Stiffness
Delivers maximum load carrying capability, with highest axial and radial stiffness.

**Anti-Backlash:
Special Purpose**



ZBA Series
– Adjustable Drag Torque/Ultra Smooth Travel
Unique patented self-lubricating polyacetal nut can be adjusted for torque ranges.



NTG Series
– Adjustable Drag Torque/Compact Size
Compact anti-backlash assembly allows drag torque to be pre-set according to system requirements.



BFW Series
– For applications that do not require anti-backlash or wear compensation
Long life at minimal cost.



MINI Series
– Miniature leadscrew assemblies
Advanced mini lead-screw motion control technology for small-scale leadscrew applications – 3 to 5 mm (1/8 to 3/16-in.). Available in NTB and NTG anti-backlash and BFW style general purpose configurations.



MICRO Series
– Revolutionary micro designs
A leadscrew / nut product design that enables a whole new range of motion control applications. Available in BFW style configurations with 2 mm (5/64-inch) diameter leadscrews.

LEADSCREW ASSEMBLIES

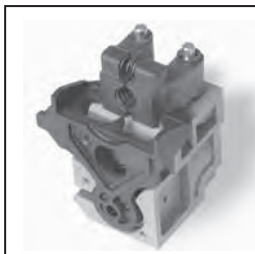

Nuts: Custom
Custom
– Haydon Kerk Motion Solutions™ can work with you to design custom nuts in a variety of materials specifically for your application.

Nut Feature Matrix

Haydon Kerk Motion Solutions. has a wide variety of standard nut designs which offer many features to choose from. Once an application's most important requirements are understood, it becomes a matter of choosing the nut which best meets those requirements. Occasionally, more than one nut might do the job, but in the vast majority of situations, one nut design will stand above the rest. The matrix below may help to narrow down the choices.

All Kerk® nuts can be modified to some degree to help them better meet specific requirements. Haydon Kerk Motion Solutions is also very willing to discuss custom nut designs where requirements and volumes justify.

LEADSCREW ASSEMBLIES

Nut Feature	Nut Style:	CMP	ZBX	ZBA	KHD	WDG	NTB	NTG	VHD	BFW
Compactness		★★★★	★★	★★	★★	★★★★	★★	★★★★	★	★★★★
Dynamic Load Capability		★★	★	★★	★★	★★	★★	★★	★★★★	★★★★
Minimal Drag Torque		★	★★	★★	★★★★	★★	★★	★★	★★★★	N/A
Vibration Damping (horizontal)		★	★★★★	★★★★	★★	★	★	★★	★★	N/A
Vibration Damping (vertical)		★	★★★★	★★★★	★	★	★	★	★	N/A
Smoothness of Operation (printing, scanning)		★	★★	★★★★	★★	★★	★★	★★★★	★★	★
Backlash/Wear Compensation Capability		★★★★	★★	★	★★★★	★★★★	★★★★	★	★★★★	N/A
Ease of User Adjustment of Drag Torque/Backlash		N/A	N/A	★★★★	★★	N/A	★	★★★★	★★	N/A
Stiffness (less axial bi-directional compliance)		★★	★★	★★	★★★★	★★★★	★★★★	★★	★★★★	N/A
Ability to Add Modifications		★	★★	★	★	★	★★★★	★	★	★★★★
Ability to manufacture with Custom Material		★	★★	★★	★	★	★★★★	★★	★	★★★★
Ability to Work with Finer Leads (<0.2-in)		★★★★	★★★★	★★★★	★★★★	★★★★	★★	★★★★	★★★★	★★★★
Ability to Work with Long Leads (>1-in)		★★★★	★★★★	★★★★	★★★★	★★★★	★★★★	★	★★★★	★★★★

GOOD ★ BETTER ★★ BEST ★★★

Comparison of Kerk® Nut Characteristics

Nominal Screw Diameter	Property	Nut Style Series								
		CMP	ZBX	ZBA	KHD	WDG	NTB	NTG	VHD	BFW
5/64-in (2mm)	Dynamic Load									10 lbs. (4.5 kg)
	Static Frictional Drag Torque									Free Wheeling
1/8-in (3mm)	Dynamic Load					10 lbs. (4.5 kg)	5 lbs. (2.3 kg)	5 lbs. (2.3 kg)		25 lbs. (11 kg)
	Static Frictional Drag Torque					4 oz.-in. max. (.03 NM max.)	.1-.5 oz.-in. (.001-.004 NM)	.1-.5 oz.-in. (.001-.004 NM)		Free Wheeling
3/16-in (4mm)	Dynamic Load	5 lbs. (2.3 kg)				10 lbs. (4.5 kg)	5 lbs. (2.3 kg)	5 lbs. (2.3 kg)		25 lbs. (11 kg)
	Static Frictional Drag Torque	4 oz.-in. (.03 NM)				4 oz.-in. max. (.03 NM max.)	.1-.5 oz.-in. (.001-.004 NM)	.1-.5 oz.-in. (.001-.004 NM)		Free Wheeling
1/4-in (6mm)	Dynamic Load	5 lbs. (2.3 kg)	5 lbs. (2.3 kg)	5 lbs. (2.3 kg)		25 lbs. (11.3 kg)	10 lbs. (4.6 kg)	10 lbs. (4.6 kg)		50 lbs. (20 kg)
	Static Frictional Drag Torque	4 oz.-in. (.03 NM)	.5-3 oz.-in. (.004-.02)	.5-2 oz.-in. (.004-.014 NM)		5 oz.-in. max. (.04 NM max)	.5-2 oz.-in. (.004-.014 NM)	.5-2 oz.-in. (.004-.014 NM)		Free Wheeling
5/16-in (8mm)	Dynamic Load	8 lbs. (3.6 kg)	NM	10 lbs. (5 kg)	20 lbs. (10 kg)	25 lbs. (11.3 kg)	20 lbs. (10 kg)	20 lbs. (10 kg)		75 lbs. (35 kg)
	Static Frictional Drag Torque	5 oz.-in. (.04 NM)	(5 kg)	1-3 oz.-in. (.01-.02 NM)	1-3 oz.-in. (.01-.02 NM)	5 oz.-in. max. (.04 NM max)	1-3 oz.-in. (.01-.02 NM)	1-3 oz.-in. (.007-.02 NM)		Free Wheeling
3/8-in (10mm)	Dynamic Load	8 lbs. (3.6 kg)	(.01-.03 NM)	10 lbs. (5 kg)	20 lbs. (10 kg)	75 lbs. (34 kg)	20 lbs. (10 kg)	20 lbs. (10 kg)		75 lbs. (35 kg)
	Static Frictional Drag Torque	5 oz.-in. (.04 NM)	(5kg)	1-3 oz.-in. (.01-.02 NM)	1-3 oz.-in. (.01-.02 NM)	9 oz.-in. max. (.06 NM max)	1-3 oz.-in. (.01-.02 NM)	1-3 oz.-in. (.007-.02 NM)		Free Wheeling
7/16-in (11mm)	Dynamic Load		(.01-.03 NM)	15 lbs. (7 kg)		75 lbs. (34 kg)	30 lbs. (13 kg)			90 lbs. (40 kg)
	Static Frictional Drag Torque		(7 kg)	2-5 oz.-in. (.014-.03 NM)		9 oz.-in. max. (.06 NM max)	1-3 oz.-in. (.007-.02 NM)			Free Wheeling
1/2-in (13mm)	Dynamic Load		(.014-.04 NM)	25 lbs. (11 kg)			100 lbs. (45 kg)		150 lbs. (68 kg)	150 lbs. (68 kg)
	Static Frictional Drag Torque		25 lbs. (11 kg)	2-5 oz.-in. (.014-.03 NM)			2-6 oz.-in. (.014-.04 NM)		2-6 oz.-in. (.014-.04 NM)	Free Wheeling
5/8-in (16mm)	Dynamic Load		3-7 oz.-in. (.02-.05 NM)	35 lbs. (16 kg)			125 lbs. (56 kg)		250 lbs. (113 kg)	225 lbs. (100 kg)
	Static Frictional Drag Torque		35 lbs. (16 kg)	3-7 oz.-in. (.02-.05 NM)			2-6 oz.-in. (.014-.04 NM)		2-6 oz.-in. (.014-.04 NM)	Free Wheeling
3/4-in (19mm)	Dynamic Load		4-8 oz.-in. (.03-.055)	55 lbs. (25 kg)			150 lbs. (68 kg)		350 lbs. (159 kg)	350 lbs. (160 kg)
	Static Frictional Drag Torque		NM	5-9 oz.-in. (.03-.063 NM)			3-7 oz.-in. (.02-.05 NM)		3-7 oz.-in. (.02-.05 NM)	Free Wheeling
7/8-in (22mm)	Dynamic Load			55 lbs. (25 kg)			200 lbs. (90 kg)		350 lbs. (159 kg)	500 lbs. (227 kg)
	Static Frictional Drag Torque			5-9 oz.-in. (.03-.063 NM)			4-8 oz.-in. (.03-.06 NM)		3-7 oz.-in. (.02-.05 NM)	Free Wheeling
15/16-in (24mm)	Dynamic Load			55 lbs. (25 kg)			200 lbs. (90 kg)			500 lbs. (227 kg)
	Static Frictional Drag Torque			5-9 oz.-in. (.03-.063 NM)			4-8 oz.-in. (.03-.06 NM)			Free Wheeling

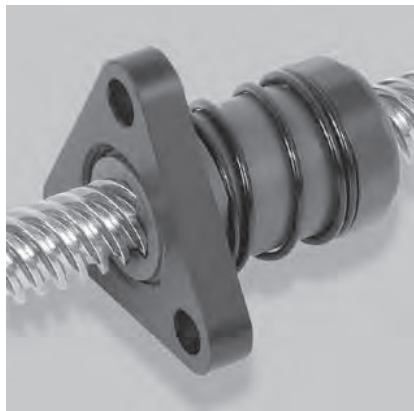

CMP Series – for light loads, compact design

The Kerk® CMP Series anti-backlash assembly utilizes a general purpose self-compensating nut in an exceptionally compact package. This allows equipment designers to utilize smaller assemblies without sacrificing stroke length. The CMP anti-backlash nut design is also ideally suited for applications using grease or oil.

The standard CMP Series assembly utilizes a self-lubricating acetal nut, axially preloaded, on a 303 stainless steel screw. End machining of screw to customer specifications and Kerkote® or Black Ice™ TFE screw coating are optional. Various axial compression springs are also available, depending on application requirements. Please consult factory for details.

CMPA and CMPP Series	Screw Diam.	Nut Diam.	Nut Length	Flange Diam.	Flange Thickness	Mounting Hole Diam.	Bolt Circle Diam.	Hub Length	Hub Diam.	Dynamic Load	Drag Torque (max.)
	A	B	C	D	E	F	G	H	J	lbs (Kg)	oz-in (NM)

CMPA Flange Mount	3/16 (4)	0.625 (16)	1.05 (26.6)	1.125 (28.6)	0.160 (4.1)	0.143 (3.7)	0.875 (22.2)	0.08 (2.04)	0.625 (15.9)	5 (2.3)	4 (.03)
	7/32 (5)	0.625 (16)	1.05 (26.6)	1.125 (28.6)	0.160 (4.1)	0.143 (3.7)	0.875 (22.2)	0.08 (2.04)	0.625 (15.9)	5 (2.3)	4 (.03)
	1/4 (6)	0.625 (16)	1.05 (26.6)	1.125 (28.6)	0.160 (4.1)	0.143 (3.7)	0.875 (22.2)	0.08 (2.04)	0.625 (15.9)	5 (2.3)	4 (.03)
CMPP (with pilot)	5/16 (8)	0.750 (19)	1.32 (33.5)	1.5 (38.1)	0.200 (5.08)	0.200 (5.08)	1.125 (28.6)	0.120 (3.05)	0.750 (19.1)	8 (3.6)	5 (.04)
	3/8 (10)	0.750 (19)	1.32 (33.5)	1.5 (38.1)	0.200 (5.08)	0.200 (5.08)	1.125 (28.6)	0.120 (3.05)	0.750 (19.1)	8 (3.6)	5 (.04)

ANTI-BACKLASH NUT ASSEMBLIES

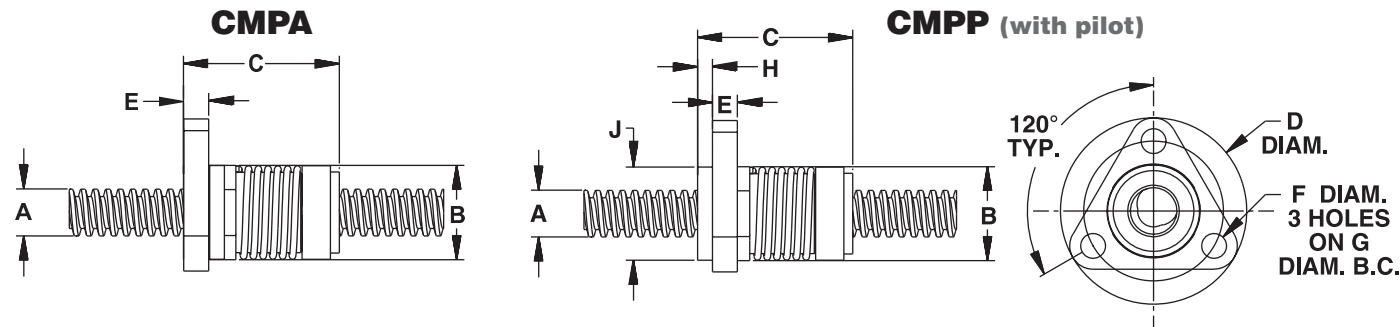

CMPT Series	Screw Diam.	Nut Diam.	Nut Length	Thread	Thread Length	Dynamic Load	Drag Torque (max.)
	A	B	C	M*	N	lbs (Kg)	oz-in (NM)

CMPT Thread Mount	3/16 (4)	0.625 (16)	1.05 (26.6)	9/16 - 18	0.240 (6.1)	5 (2.3)	4 (.03)
	7/32 (5)	0.625 (16)	1.05 (26.6)	9/16 - 18	0.240 (6.1)	5 (2.3)	4 (.03)
	1/4 (6)	0.625 (16)	1.05 (26.6)	9/16 - 18	0.240 (6.1)	5 (2.3)	4 (.03)
	5/16 (8)	0.750 (19)	1.32 (33.5)	5/8 - 18	0.320 (8.1)	8 (3.6)	5 (.04)
	3/8 (10)	0.750 (19)	1.32 (33.5)	5/8 - 18	0.320 (8.1)	8 (3.6)	5 (.04)

* metric available as required

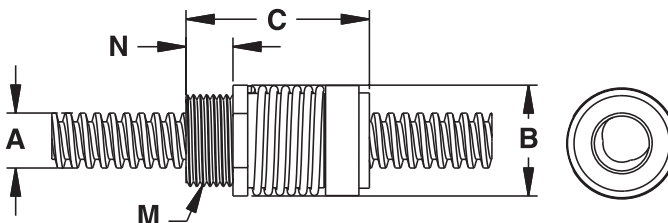

ZBX Series – for lighter loads

The patented Kerk® ZBX Series anti-backlash assembly offers an effective linear actuator for design operations requiring precise positional accuracy and repeatability, with minimum cost.

The standard ZBX unit utilizes a patented self-lubricating polyacetal nut radially preloaded on a 303 stainless steel screw.



The ZBX assembly, through its unique transfer of loads, offers exceptional torque consistency and repeatability when traversing in either direction. The inherent damping qualities of the ZBX design make it ideally suited for vertical applications requiring noise or vibration control.

End machining to customer specifications and Kerkote® TFE screw coating are optional, as are designs for special operating configurations or environments.

ZBXA Series: Flange Mount

	Screw Diam.	Nut Diam.	Nut Length	Flange Diam.	Flange Thickness	Mounting Hole Diam.	Bolt Circle Diam.	Dynamic Load	Drag Torque
	A inch (mm)	B inch (mm)	C inch (mm)	D inch (mm)	E inch (mm)	F inch (mm)	G inch (mm)	lbs (Kg)	oz-in (NM)
ZBXA Series Flange Mount	1/4 (6)	.50 (12.7)	1.0 (26)	1.0 (25.4)	.18 (4.6)	.140 (3.6)	.750 (19.1)	5 (2.3)	.5-3 (.004-.02)
	5/16 (8)	.70 (17.8)	1.9 (48)	1.5 (38.1)	.18 (4.6)	.200 (5.08)	1.125 (28.6)	10 (5)	1-5 (.007-.03)
	3/8 (10)	.70 (17.8)	1.9 (48)	1.5 (38.1)	.18 (4.6)	.200 (5.08)	1.125 (28.6)	10 (5)	1-5 (.007-.03)
	7/16 (11)	.80 (20.3)	1.9 (48)	1.5 (38.1)	.18 (4.6)	.200 (5.08)	1.125 (28.6)	15 (7)	2-6 (.014-.04)
	1/2 (13)	.89 (22.6)	2.0 (51)	1.62 (41.2)	.26 (6.6)	.200 (5.08)	1.1250 (31.8)	25 (11)	3-7 (.02-.05)
	5/8 (16)	1.06 (26.9)	2.0 (51)	1.75 (44.5)	.26 (6.6)	.200 (5.08)	1.375 (34.9)	35 (16)	4-8 (.028-.055)

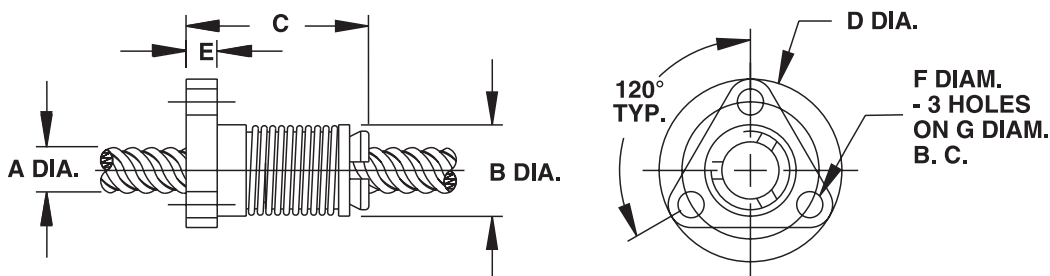

ZBXT Series: Thread Mount

	Screw Diam.	Nut Diam.	Nut Length	Flange Diam.	Flange Thickness	Thread	Thread Length	Dynamic Load	Drag Torque
	A inch (mm)	B inch (mm)	C inch (mm)	D inch (mm)	E inch (mm)	M* inch	N inch (mm)	lbs (Kg)	oz-in (NM)
ZBXT Series Thread Mount	1/4 (6)	.50 (12.7)	1.3 (33)	.80 (20.3)	.22 (5.6)	5/8 - 18	.16 (4.1)	5 (2.3)	.5-3 (.004-.02)
	5/16 (8)	.70 (17.8)	2.2 (56)	1.00 (25.4)	.17 (4.3)	5/8 - 18	3.8 (9.7)	10 (5)	1-5 (.007-.03)
	3/8 (10)	.70 (17.8)	2.2 (56)	1.00 (25.4)	.17 (4.3)	5/8 - 18	.38 (9.7)	10 (5)	1-5 (.007-.03)
	7/16 (11)	.80 (20.3)	2.3 (59)	1.00 (25.4)	.12 (3.1)	15/16 - 16	.38 (9.7)	15 (7)	2-6 (.014-.04)
	1/2 (13)	.89 (22.6)	2.3 (59)	1.02 (25.9)	.12 (3.1)	15/16 - 16	.38 (9.7)	25 (11)	3-7 (.02-.05)
	5/8 (16)	1.06 (26.9)	2.4 (61)	1.06 (26.9)	.15 (3.8)	15/16 - 16	.50 (12.7)	35 (16)	4-8 (.028-.055)

* metric available as required

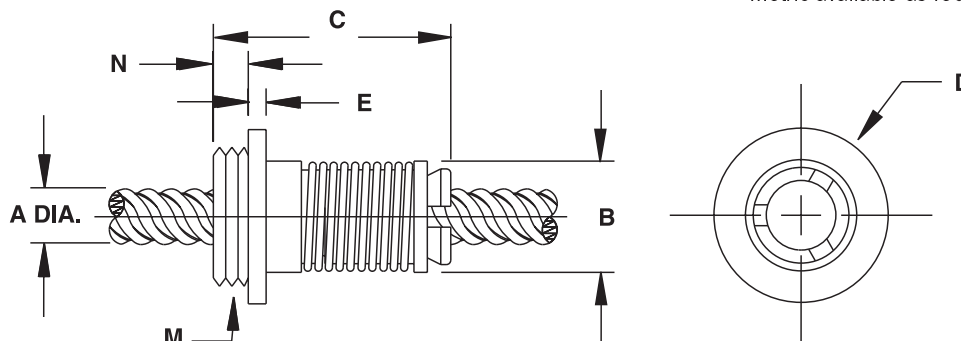



KHD Series – for moderate loads, low drag torque

The Kerk® KHD Series anti-backlash assembly makes use of the Kerk patented AXIAL TAKE-UP MECHANISM (see *Leadscrew Assemblies: Anti-Backlash Technologies* section) to provide backlash compensation. The unique split nut with torsional take-up provides increased load capacity and axial stiffness over comparably sized ZBX units.

Although the KHD offers high axial stiffness, frictional drag torque (1-3 oz.-in.) is very low. The anti-backlash mechanism in the KHD unit eliminates the need for load compensating preload forces.

The assembly consists of a 303 stainless steel screw mated with a self-lubricating polyacetal nut. End machining to customer specifications and Kerkote® TFE screw coating are optional.

KHDA Series: Flange Mount

	Screw Diam.	Nut Diam.	Nut Length	Flange Diam.	Flange Thickness	Mounting Hole Diam.	Bolt Circle Diam.	Dynamic Load	Drag Torque
	A inch (mm)	B inch (mm)	C inch (mm)	D inch (mm)	E inch (mm)	F inch (mm)	G inch (mm)	lbs (Kg)	oz-in (NM)
KHDA Series Flange Mount	5/16 (8)	.80 (20.3)	2.0 (50.8)	1.50 (38.1)	.19 (4.8)	.200 (5.08)	1.125 (28.58)	20 (10)	1-3 (.007-.020)
	3/8 (10)	.80 (20.3)	2.0 (50.8)	1.50 (38.1)	.19 (4.8)	.200 (5.08)	1.125 (28.58)	20 (10)	1-3 (.007-.020)

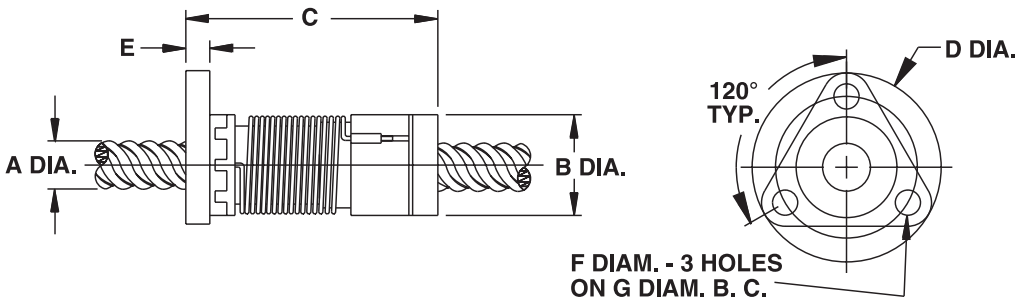

KHDT Series: Thread Mount

	Screw Diam.	Nut Diam.	Nut Length	Flange Diam.	Flange Thickness	Thread	Thread Length	Dynamic Load	Drag Torque
	A inch (mm)	B inch (mm)	C inch (mm)	D inch (mm)	E inch (mm)	M* inch	N inch (mm)	lbs (Kg)	oz-in (NM)
KHDT Series Thread Mount	5/16 (8)	.80 (20.3)	2.2 (55.9)	.75 (19.1)	.05 (1.27)	3/4-20	.35 (8.9)	20 (10)	1-3 (.007-.020)
	3/8 (10)	.80 (20.3)	2.2 (55.9)	.75 (19.1)	.05 (1.27)	3/4-20	.35 (8.9)	20 (10)	1-3 (.007-.020)

* metric available as required

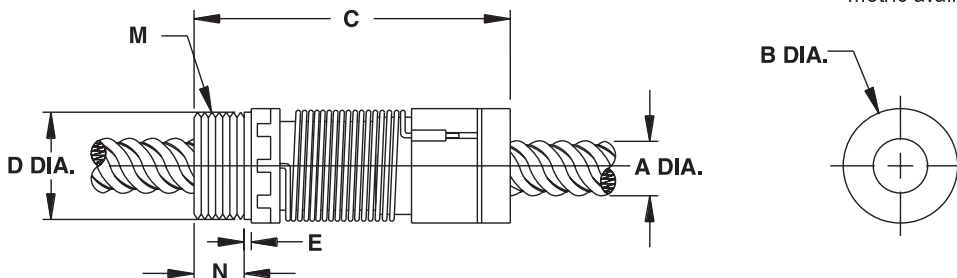

WDG Series – for moderate loads, compact designs

The Kerk® WDG Series anti-backlash assembly utilizes an exceptionally compact design to provide stiffness and balanced accuracy for precise positioning. The unique wedge design locks the nut at the correct preload without excessive drag.

Shorter than other self-compensating nuts with similar performance, the W nut permits the design of smaller assemblies without sacrificing stroke length. Nut wear or momentary overload is accommodated through the WDG Series' compensation mechanism, which maintains positional accuracy in demanding applications.

The standard W Series assembly utilizes a self-lubricating acetal nut, axially preloaded, on a 303 stainless steel screw. End machining to customer specifications and Kerkote® or Black Ice™ TFE screw coating are optional, as are designs for special operating configurations or environments.

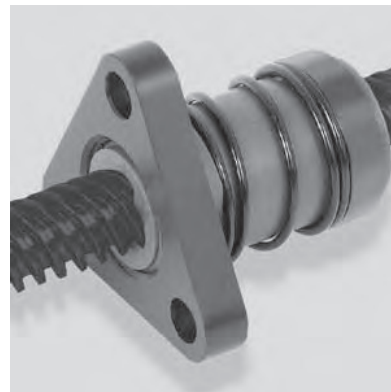

WDGA and WDGP Series	Screw Diam.	Nut Diam.	Nut Length	Flange Diam.	Flange Thickness	Mounting Hole Diam.	Bolt Circle Diam.	Hub Length	Hub Diam.	Dynamic Load	Drag Torque (max.)
	A	B	C	D	E	F	G	H	J	lbs (Kg)	oz-in (NM)

WDGA Flange Mount & WDGP (with pilot)	3/16 (4)	0.625 (16)	1.05 (26.6)	1.125 (28.6)	0.160 (4.1)	0.143 (3.7)	0.875 (22.2)	0.08 (2.04)	0.625 (15.9)	10 (4.5)	4 (.03)
	7/32 (5)	0.625 (16)	1.05 (26.6)	1.125 (28.6)	0.160 (4.1)	0.143 (3.7)	0.875 (22.2)	0.08 (2.04)	0.625 (15.9)	10 (4.5)	4 (.03)
	1/4 (6)	0.625 (16)	1.05 (26.6)	1.125 (28.6)	0.160 (4.1)	0.143 (3.7)	0.875 (22.2)	0.08 (2.04)	0.625 (15.9)	10 (4.5)	4 (.03)
	5/16 (8)	0.750 (19)	1.32 (33.5)	1.5 (38.1)	0.200 (5.08)	0.200 (5.08)	1.125 (28.6)	0.120 (3.05)	0.750 (19.1)	25 (11.3)	5 (.04)
	3/8 (10)	0.750 (19)	1.32 (33.5)	1.5 (38.1)	0.200 (5.08)	0.200 (5.08)	1.125 (28.6)	0.120 (3.05)	0.750 (19.1)	25 (11.3)	5 (.04)
	7/16 (11)	1.00 (25.4)	2.078 (52.8)	1.750 (44.5)	0.250 (6.35)	0.220 (5.6)	1.406 (35.7)	0.255 (6.48)	1.000 (25.4)	75 (34)	9 (.06)
	1/2 (13)	1.00 (25.4)	2.078 (52.8)	1.750 (44.5)	0.250 (6.35)	0.220 (5.6)	1.406 (35.7)	0.255 (6.48)	1.000 (25.4)	75 (34)	9 (.06)

ANTI-BACKLASH NUT ASSEMBLIES

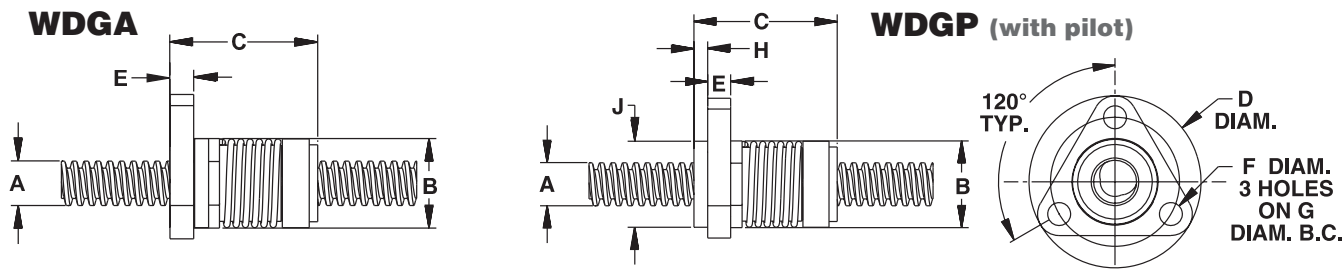

WDGT Series	Screw Diam.	Nut Diam.	Nut Length	Thread	Thread Length	Dynamic Load	Drag Torque (max.)
	A	B	C	M*	N	lbs (Kg)	oz-in (NM)

WDGT Thread Mount	3/16 (4)	0.625 (16)	1.05 (26.6)	9/16 - 18	0.240 (6.1)	10 (4.5)	4 (.03)
	7/32 (5)	0.625 (16)	1.05 (26.6)	9/16 - 18	0.240 (6.1)	10 (4.5)	4 (.03)
	1/4 (6)	0.625 (16)	1.05 (26.6)	9/16 - 18	0.240 (6.1)	10 (4.5)	4 (.03)
	5/16 (8)	0.750 (19)	1.32 (33.5)	5/8 - 18	0.320 (8.1)	25 (11.3)	5 (.04)
	3/8 (10)	0.750 (19)	1.32 (33.5)	5/8 - 18	0.320 (8.1)	25 (11.3)	5 (.04)
	7/16 (11)	1.00 (25.4)	2.078 (52.8)	15/16 - 16	0.500 (12.7)	75 (34)	9 (.06)
	1/2 (13)	1.00 (25.4)	2.078 (52.8)	15/16 - 16	0.500 (12.7)	75 (34)	9 (.06)

* metric available as required

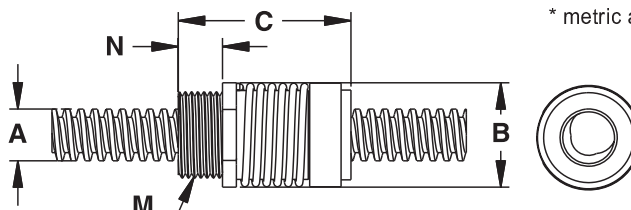



NTB Series – full range, flexible designs

The Kerk® NTB Series anti-backlash assembly is designed for higher load applications than the ZBX or KHD series units. Using the specially designed take up mechanism, it maintains axial stiffness throughout its life while system torque is held to a minimum. The need to highly pre-load the nut to compensate for load has been eliminated with the Kerk NTB Series assembly.

The nut is manufactured with a self-lubricating polyacetal designed to run efficiently on the precision rolled shafting. Screws are 303 stainless and are available with the proprietary long - life Kerkote® TFE coating. The NTB's simple, compact design can be easily modified for custom applications.

The NTB assembly provides low drag torque, high system stiffness, smooth operation, and long life throughout its load and speed range.

NTB Series: Flange Mount

	Screw Diam.	Nut Diam.	Nut Length	Flange Diam.	Flange Thickness	Mounting Hole Diam.	Bolt Circle Diam.	Hub Width	Hub Diam.	Dynamic Load	Drag Torque
	A	B	C	D	E	F	G	H	J		
	inch (mm)	inch (mm)	inch (mm)	inch (mm)	inch (mm)	inch (mm)	inch (mm)	inch (mm)	inch (mm)	lbs (Kg)	oz-in (NM)
NTBA Triangular Flange	1/4 (6)	.52 (13.2)	1.1 (28)	1.00 (25.4)	.16 (4.0)	.143 (3.63)	.750 (19.1)	.08 (2.0)	.500 (12.7)	10 (4.5)	.5-2 (.004-.014)
	5/16 (8)	.80 (20.3)	1.8 (46)	1.50 (38.1)	.20 (5.1)	.200 (5.08)	1.125 (28.6)	.10 (2.54)	.750 (19.1)	20 (9.1)	1-3 (.007-.02)
	3/8 (10)	.80 (20.3)	1.8 (46)	1.50 (38.1)	.20 (5.1)	.200 (5.08)	1.125 (28.6)	.10 (2.54)	.750 (19.1)	20 (9.1)	1-3 (.007-.02)
	7/16 (11)	.90 (22.9)	1.8 (46)	1.62 (41.2)	.23 (5.7)	.200 (5.08)	1.1250 (31.8)	.10 (2.54)	.875 (22.2)	30 (13.6)	1-3 (.007-.02)
NTBF Round Flange	1/2 (13)	1.06 (26.9)	2.1 (54)	1.75 (44.5)	.25 (6.4)	.220 (5.59)	1.406 (35.71)	.12 (3.0)	1.00 (25.4)	100 (45.5)	2-6 (.014-.04)
	5/8 (16)	1.38 (34.9)	2.3 (59)	2.13 (54.1)	.28 (7.0)	.220 (5.59)	1.750 (44.45)	.10 (2.54)	1.25 (31.8)	125 (56.8)	2-6 (.014-.04)
	3/4 (19)	1.56 (39.6)	2.7 (67)	2.38 (60.5)	.31 (7.9)	.220 (5.59)	2.000 (50.80)	.10 (2.54)	1.50 (38.1)	150 (68.2)	3-7 (.02-.05)
	7/8 (22)	1.75 (44.5)	2.8 (70)	2.63 (66.8)	.38 (9.5)	.220 (5.59)	2.250 (57.15)	.12 (3.0)	1.75 (44.5)	200 (90.9)	4-8 (.03-.06)
	15/16 (24)	1.75 (44.5)	2.8 (70)	2.63 (66.8)	.38 (9.5)	.220 (5.59)	2.250 (57.15)	.12 (3.0)	1.75 (44.5)	200 (90.9)	4-8 (.03-.06)

ANTI-BACKLASH NUT ASSEMBLIES

NTB MINI Series – see MINI Series Products

Triangular Flange

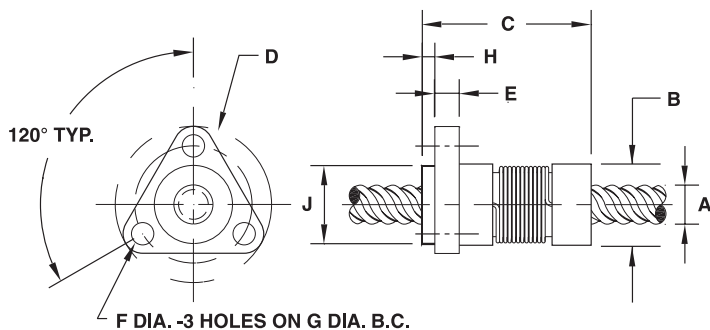

Round Flange

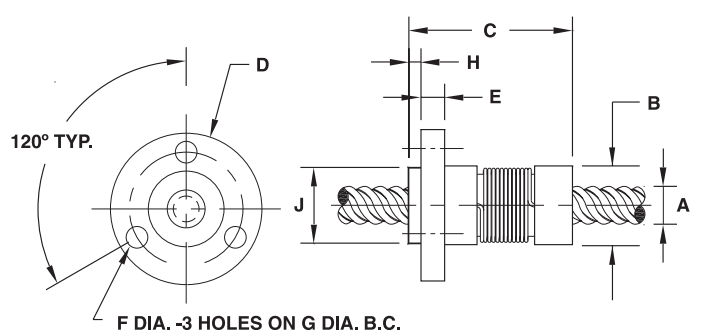

NTBT Series: Thread Mount

	Screw Diam.	Nut Diam.	Nut Length	Thread	Thread Length	Dynamic Load	Drag Torque
	A inch (mm)	B inch (mm)	C inch (mm)	M* inch (mm)	N inch (mm)	lbs (Kg)	oz-in (NM)
NTBT Thread Mount 1/4 to 7/16-in	1/4 (6)	.52 (13.2)	1.1 (28)	7/16-20	.25 (6.4)	10 (4.5)	5-2 (.004-.014)
	5/16 (8)	.80 (20.3)	1.8 (45)	3/4-20	.38 (9.5)	20 (9.1)	1-3 (.007-.02)
	3/8 (10)	.80 (20.3)	1.8 (45)	3/4-20	.38 (9.5)	20 (9.1)	1-3 (.007-.02)
	7/16 (11)	.90 (22.9)	1.8 (46)	13/16-16	.38 (9.5)	30 (13.6)	1-3 (.007-.02)

NTBT Thread Mount 1/2 to 15/16-in	1/2 (13)	1.06 (26.9)	2.1 (54)	15/16-16	.38 (9.5)	100 (45.5)	2-6 (.014-.04)
	5/8 (16)	1.38 (34.9)	2.3 (59)	1 1/8-16	.38 (9.5)	125 (56.8)	2-6 (.014-.04)
	3/4 (19)	1.56 (39.6)	2.7 (67)	1 3/8-16	.50 (12.7)	150 (68.2)	3-7 (.02-.05)
	7/8 (22)	1.75 (44.5)	2.8 (70)	1 9/16-16	.50 (12.7)	200 (90.9)	4-8 (.03-.06)
	15/16 (24)	1.75 (44.5)	2.8 (70)	1 9/16-16	.50 (12.7)	200 (90.9)	4-8 (.03-.06)

NTB MINI Series – see MINI Series Products

* metric available as required

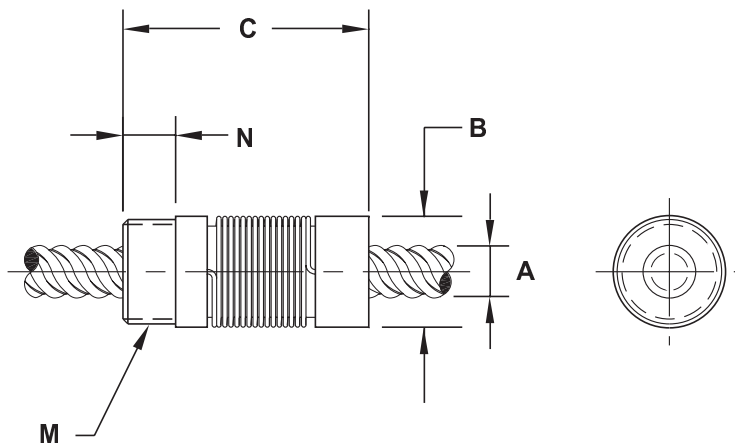

ANTI-BACKLASH NUT ASSEMBLIES



The Kerk® VHD Series anti-backlash assembly provides the maximum load carrying capability and the highest axial and radial stiffness of any Kerk nut assembly. Designed for smooth, quiet operation and long life, the VHD assembly provides low drag torque by making use of the patented Kerk AXIAL TAKE-UP MECHANISM (see *Leadscrew Assemblies: Anti-Backlash Technologies* section). Drag and wear associated with high pre-load forces are eliminated with the VHD Series. Screws are 303 stainless steel with Kerk's custom Kerkote® TFE extended life coating optional.

Assemblies are available cut-to-length or with screws machined to your requirements.

VHD Series: Flange Mount

	Screw Diam.	Nut Diam.	Nut Length	Flange Diam.	Flange Thickness	Mounting Hole Diam.	Bolt Circle Diam.	Hub Width	Hub Diam.	Dynamic Load	Drag Torque
	A	B	C	D	E	F	G	H	J		
	inch (mm)	inch (mm)	inch (mm)	inch (mm)	inch (mm)	inch (mm)	inch (mm)	inch (mm)	inch (mm)	lbs (Kg)	oz-in (NM)
VHDF Flange Mount	1/2 (13)	1.12 (28.5)	2.3 (59)	1.75 (44.5)	.23 (5.9)	.22 (5.60)	1.406 (35.71)	.12 (3.1)	.93 (23.62)	150 (68)	2-6 (.014-.02)
	5/8 (16)	1.38 (35.1)	2.6 (66)	2.08 (53)	.28 (7.1)	.22 (5.60)	1.750 (44.45)	N/A	N/A	250 (113)	2-6 (.014-.02)
	3/4 (19)	1.62 (41.2)	2.8 (71)	2.38 (60.5)	.31 (7.9)	.22 (5.60)	2.000 (50.80)	N/A	N/A	350 (159)	3-7 (.02-.05)
	7/8 (22)	1.62 (41.2)	2.8 (71)	2.38 (60.5)	.31 (7.9)	.22 (5.60)	2.000 (50.80)	N/A	N/A	350 (159)	3-7 (.02-.05)

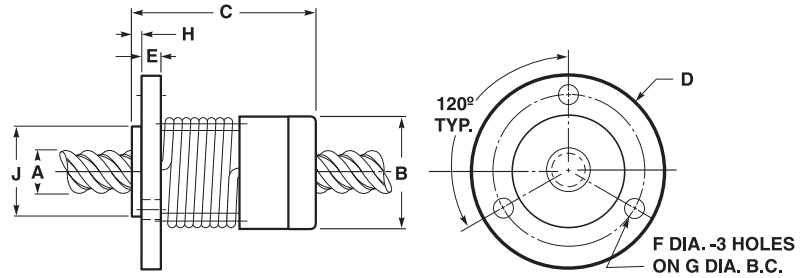

VHD Series: Thread Mount

	Screw Diam.	Nut Diam.	Nut Length	Thread	Thread Length	Dynamic Load	Drag Torque
	A	B	C	M*	N	lbs (Kg)	oz-in (NM)
	inch (mm)	inch (mm)	inch (mm)	inch (mm)	inch (mm)		
VHDT Thread Mount	1/2 (13)	1.12 (28.5)	2.5 (64)	15/16-16	.50 (12.7)	150 (68)	2-6 (.014-.04)
	5/8 (16)	1.38 (35.1)	2.8 (72)	1 1/4-16	.50 (12.7)	250 (113)	2-6 (.014-.04)
	3/4 (19)	1.62 (41.2)	3.12 (79)	1 3/8-16	.50 (12.7)	350 (159)	3-7 (.02-.05)
	7/8 (22)	1.62 (41.2)	3.12 (79)	1 3/8-16	.50 (12.7)	350 (159)	3-7 (.02-.05)

* metric available as required

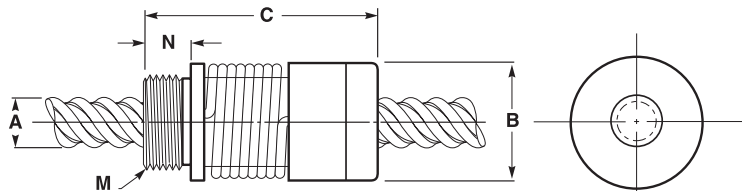

ZBA Series – adjustable drag torque/ultra smooth travel



ANTI-BACKLASH NUT
ASSEMBLIES

The patented Kerk® ZBA Series offers a cost effective anti-backlash assembly for applications requiring precise positional accuracy and repeatability. The ZBA has been developed specifically for those applications that require very smooth and consistent motion such as printing, scanning, and coordinate measurement systems.

An added benefit of the ZBA design is the ability to manually adjust the drag torque setting to match the specific requirements of the application. This drag torque can also be set at the factory to meet individual customer specifications. The inherent damping qualities of the ZBA design make it ideally suited for applications requiring noise or vibration control.

The standard ZBA unit utilizes a self-lubricating polyacetal nut radially preloaded on a 303 stainless steel screw. End machining to customer specifications and Kerkote® TFE screw coating are optional.

ZBAA Series: Flange Mount

	Screw Diam.	Nut Diam.	Nut Length	Flange Diam.	Flange Thickness	Mounting Hole Diam.	Bolt Circle Diam.	Dynamic Load	Drag Torque
	A inch (mm)	B inch (mm)	C inch (mm)	D inch (mm)	E inch (mm)	F inch (mm)	G inch (mm)	lbs (Kg)	oz-in (NM)
ZBAA Flange Mount	1/4 (6)	.53 (13.5)	1.00 (25.4)	1.00 (25.4)	.18 (4.6)	.143 (3.6)	.750 (19.05)	5 (2.3)	.5-2 (.004-.014)
	5/16 (8)	.74 (18.8)	1.9 (48)	1.50 (38.1)	.18 (4.6)	.200 (5.08)	1.125 (28.58)	10 (5)	1-3 (.007-.02)
	3/8 (9)	.74 (18.8)	1.9 (48)	1.50 (38.1)	.18 (4.6)	.200 (5.08)	1.125 (28.58)	10 (5)	1-3 (.007-.02)
	7/16 (11)	.80 (20.3)	1.9 (48)	1.50 (38.1)	.18 (4.6)	.200 (5.08)	1.125 (28.58)	15 (7)	2-5 (.014-.03)
	1/2 (13)	.89 (22.6)	2.00 (50.8)	1.62 (41.2)	.28 (7.1)	.200 (5.08)	1.250 (31.75)	25 (11)	2-5 (.014-.03)
	5/8 (16)	1.06 (26.9)	2.00 (50.8)	1.75 (44.5)	.28 (7.1)	.200 (5.08)	1.375 (34.93)	35 (16)	3-7 (.02-.05)
	3/4 (19)	1.70 (43.2)	2.88 (73.2)	2.63 (66.8)	.38 (9.6)	.218 (5.5)	2.25 (57.2)	55 (25)	5-9 (.03-.064)
	7/8 (22)	1.70 (43.2)	2.88 (73.2)	2.63 (66.8)	.38 (9.6)	.218 (5.5)	2.25 (57.2)	55 (25)	5-9 (.03-.064)
	15/16 (24)	1.70 (43.2)	2.88 (73.2)	2.63 (66.8)	.38 (9.6)	.218 (5.5)	2.25 (57.2)	55 (25)	5-9 (.03-.064)

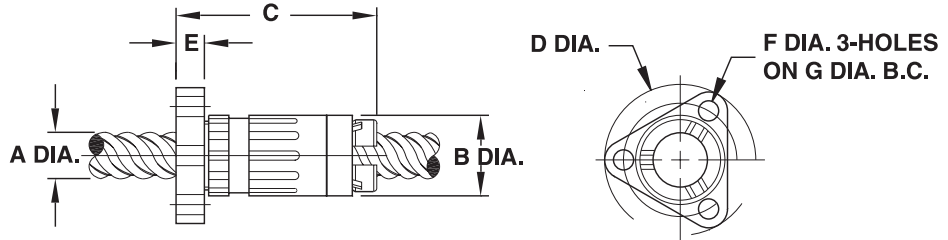

ZBAT Series: Thread Mount

	Screw Diam.	Nut Diam.	Nut Length	Flange Diam.	Flange Thickness	Thread	Thread Length	Dynamic Load	Drag Torque
	A inch (mm)	B inch (mm)	C inch (mm)	D inch (mm)	E inch (mm)	M* inch	N inch (mm)	lbs (Kg)	oz-in (NM)
ZBAT Thread Mount	1/4 (6)	.53 (13.5)	1.3 (33)	.80 (20.3)	.12 (3.1)	5/8-18	.16 (4.1)	5 (2.3)	.5-2 (.004-.014)
	5/16 (8)	.74 (18.8)	2.2 (56)	1.00 (25.4)	.15 (3.8)	5/8-18	.38 (9.7)	10 (5)	1-3 (.007-.02)
	3/8 (10)	.74 (18.8)	2.2 (56)	1.00 (25.4)	.15 (3.8)	5/8-18	.38 (9.7)	10 (5)	1-3 (.007-.02)
	7/16 (11)	.80 (20.3)	2.3 (59)	1.00 (25.4)	.10 (2.5)	15/16-16	.38 (9.7)	15 (7)	2-5 (.014-.03)
	1/2 (13)	.89 (22.6)	2.3 (59)	1.04 (26.4)	.10 (2.5)	15/16-16	.38 (9.7)	25 (11)	2-5 (.014-.03)
	5/8 (16)	1.06 (26.9)	2.3 (58.9)	1.06 (26.9)	.14 (3.6)	15/16-16	.50 (12.7)	35 (16)	3-7 (.02-.05)

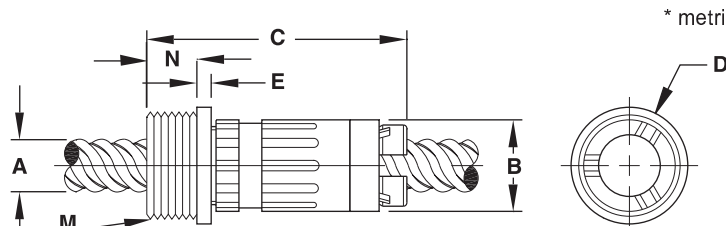

* metric available as required

NTG Series – adjustable drag torque/compact size

The adjustable Kerk® NTG Series offers a cost effective anti-backlash assembly for applications requiring precise positional accuracy, repeatability, and smoothness. The NTG has been developed specifically for demanding applications that require zero backlash with minimal drag torque. With its compact size and no moving components, the NTG can also be easily incorporated into customer specified, custom molded parts.

An integral part of the NTG design is the ability to manually adjust the drag torque setting to match specific requirements of the application. This drag torque can also be set at the factory to meet individual customer specifications. This is especially effective with fine leads.

The standard NTG unit utilizes a self-lubricating polyacetal nut on a precision rolled 303 stainless steel screw. End machining to customer specifications and Kerkote® TFE screw coating are optional.



NTGA Series: Flange Mount

	Screw Diam.	Nut Diam.	Nut Length	Flange Diam.	Flange Thickness	Mounting Hole Diam.	Bolt Circle Diam.	Dynamic Load	Drag Torque
	A inch (mm)	B inch (mm)	C inch (mm)	D inch (mm)	E inch (mm)	F inch (mm)	G inch (mm)	lbs (Kg)	oz-in (NM)
NTGA Flange Mount	1/4 (6)	.52 (13.2)	.8 (20.3)	1.00 (25.4)	.16 (4.0)	.143 (3.63)	.750 (19.1)	10 (4.5)	.5-2 (.004-.014)
	5/16 (8)	.80 (20.3)	1.0 (25.4)	1.50 (38.1)	.20 (5.1)	.197 (5.00)	1.125 (28.6)	20 (9.1)	1-3 (.007-.02)
	3/8 (10)	.80 (20.3)	1.0 (25.4)	1.50 (38.1)	.20 (5.1)	.197 (5.00)	1.125 (28.6)	20 (9.1)	1-3 (.007-.02)

NTG MINI Series – see MINI Series Products

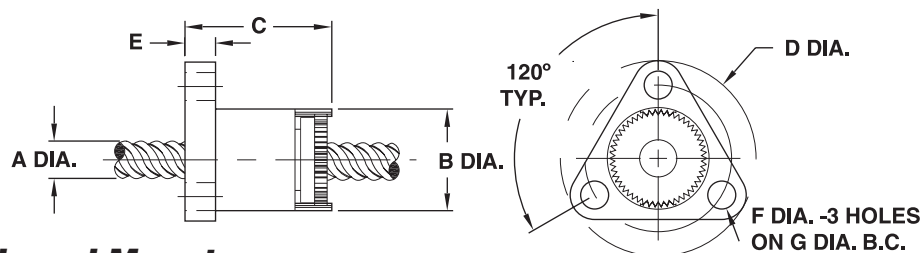

NTGT Series: Thread Mount

	Screw Diam.	Nut Diam.	Nut Length	Thread	Thread Length	Dynamic Load	Drag Torque
	A inch (mm)	B inch (mm)	C inch (mm)	M* inch	N inch (mm)	lbs (Kg)	oz-in (NM)
NTGT Thread Mount	1/4 (6)	.520 (13.2)	.9 (22)	7/16 - 20	250 (6.35)	10 (4.5)	.5-2 (.004-.014)
	5/16 (8)	.800 (20.3)	1.2 (30)	3/4 - 20	.375 (9.53)	20 (9.1)	1-3 (.007-.02)
	3/8 (10)	.800 (20.3)	1.2 (30)	3/4 - 20	.375 (9.53)	20 (9.1)	1-3 (.007-.02)

NTG MINI Series – see MINI Series Products

* metric available as required

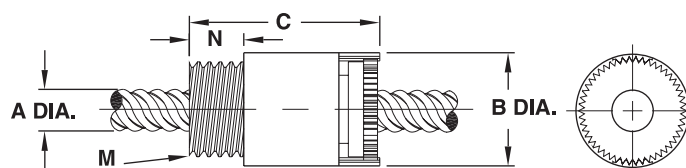

BFW Series – conventional style, without “anti-backlash” function

The Kerk® BFW Series general purpose “free-wheeling” nut is for applications not requiring anti-backlash and wear compensation. It provides effective power transmission at minimum cost, and features long life, self-lubricating polyacetal nuts.



The secure mounting and convenience of a circular flange is standard on the BFW nuts with triangular flange and thread mounting as an option. Many custom configurations are available.

Screws are 303 stainless steel with extended life, custom Kerkote® TFE coating optional. Assemblies can be supplied cut-to-length or with ends machined to customer requirements.

BFWF Series: Flange Mount (Round)

	Screw Diam.	Nut Diam.	Nut Length	Flange Diam.	Flange Thickness	Mounting Hole Diam.	Bolt Circle Diam.	Dynamic Load
	A	B	C	D	E	F	G	
	inch (mm)	inch (mm)	inch (mm)	inch (mm)	inch (mm)	inch (mm)	inch (mm)	lbs (Kg)
BFWF Round Flange	1/4 (6)	.50 (12.7)	1.0 (25.4)	1.00 (25.4)	.19 (4.8)	.140 (3.56)	.750 (19.05)	50 (20)
	5/16 (8)	.63 (15.9)	1.0 (25.4)	1.13 (28.7)	.19 (4.8)	.140 (3.56)	.875 (22.23)	75 (35)
	3/8 (10)	.63 (15.9)	1.0 (25.4)	1.13 (28.7)	.19 (4.8)	.140 (3.56)	.875 (22.23)	75 (35)
	7/16 (11)	.75 (19.1)	1.5 (38)	1.50 (38.1)	.19 (4.8)	.203 (5.16)	1.125 (28.58)	90 (40)
	1/2 (13)	.75 (19.1)	1.5 (38)	1.50 (38.1)	.19 (4.8)	.203 (5.16)	1.125 (28.58)	150 (68)
	5/8 (16)	.88 (22.2)	1.5 (38)	1.50 (38.1)	.19 (4.8)	.203 (5.16)	1.188 (30.18)	225 (100)
	3/4 (19)	1.12 (28.4)	2.0 (51)	1.75 (44.4)	.25 (6.4)	.203 (5.16)	1.438 (36.53)	350 (160)
	7/8 (22)	1.50 (38.1)	2.0 (51)	2.25 (57.1)	.25 (6.4)	.203 (5.16)	1.875 (47.63)	500 (227)
	15/16 (24)	1.50 (38.1)	2.0 (51)	2.25 (57.1)	.25 (6.4)	.203 (5.16)	1.875 (47.63)	500 (227)

BFW MINI Series – see MINI Series Products

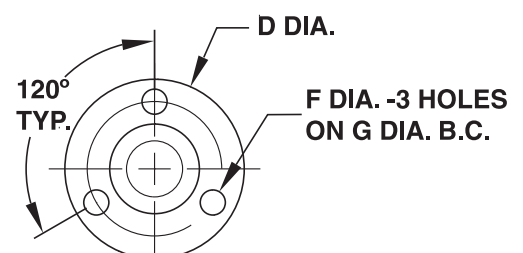
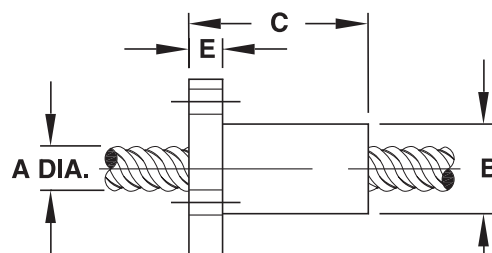

FREE-WHEELING
and SPECIALTY NUTS

BFWA Series: Flange Mount (Triangular)

	Screw Diam.	Nut Diam.	Nut Length	Flange Diam.	Flange Thickness	Mounting Hole Diam.	Bolt Circle Diam.	Dynamic Load
	A inch (mm)	B inch (mm)	C inch (mm)	D inch (mm)	E inch (mm)	F inch (mm)	G inch (mm)	lbs (Kg)
BFWA Triangular Flange	1/4 (6)	.50 (12.7)	1.0 (25.4)	1.00 (25.4)	.17 (4.3)	.143 (3.63)	.750 (19.05)	50 (20)
	5/16 (8)	.66 (16.6)	1.9 (48.3)	1.50 (38.1)	.17 (4.3)	.197 (5.00)	1.125 (28.58)	75 (35)
	3/8 (10)	.66 (16.6)	1.9 (48.3)	1.50 (38.1)	.17 (4.3)	.197 (5.00)	1.125 (28.58)	75 (35)
	7/16 (11)	.75 (19.1)	1.9 (48.3)	1.50 (38.1)	.17 (4.3)	.197 (5.00)	1.125 (28.58)	90 (40)
	1/2 (13)	.75 (19.1)	1.9 (48.3)	1.50 (38.1)	.17 (4.3)	.197 (5.00)	1.125 (28.58)	150 (68)

BFW MINI Series
– see MINI Series
Products

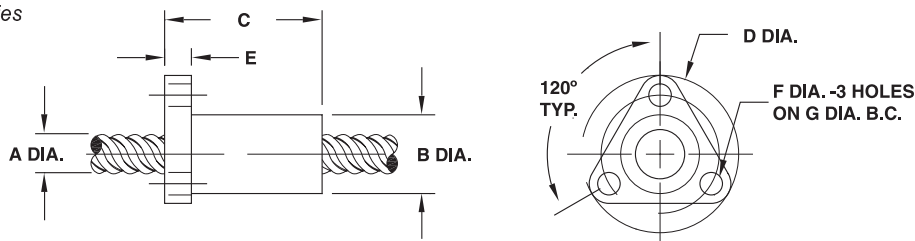

BFWT Series: Thread Mount

	Screw Diam.	Nut Diam.	Nut Length	Thread	Thread Length	Dynamic Load
	A inch (mm)	B inch (mm)	C inch (mm)	M* inch	N inch (mm)	lbs (Kg)
BFWT Thread Mount	1/4 (6)	.63 (15.9)	1.0 (25.4)	9/16 - 18	.187 (4.75)	50 (20)
	5/16 (8)	.75 (19.1)	1.0 (25.4)	5/8 - 18	.250 (6.35)	75 (35)
	3/8 (10)	.75 (19.1)	1.0 (25.4)	5/8 - 18	.250 (6.35)	75 (35)
	7/16 (11)	1.00 (25.4)	1.5 (38.1)	15/16 - 16	.375 (9.53)	90 (40)
	1/2 (13)	1.00 (25.4)	1.5 (38.1)	15/16 - 16	.375 (9.53)	150 (68)
	5/8 (16)	1.00 (25.4)	1.5 (38.1)	15/16 - 16	.375 (9.53)	225 (100)
	3/4 (19)	1.50 (38.1)	2.0 (51)	1 3/8 - 16	.500 (12.70)	350 (160)
	7/8 (22)	1.50 (38.1)	2.0 (51)	1 3/8 - 16	.500 (12.70)	500 (227)
	15/16 (24)	1.50 (38.1)	2.0 (51)	1 3/8 - 16	.500 (12.70)	500 (227)

BFW MINI Series – see MINI
Series Products

* metric available as required

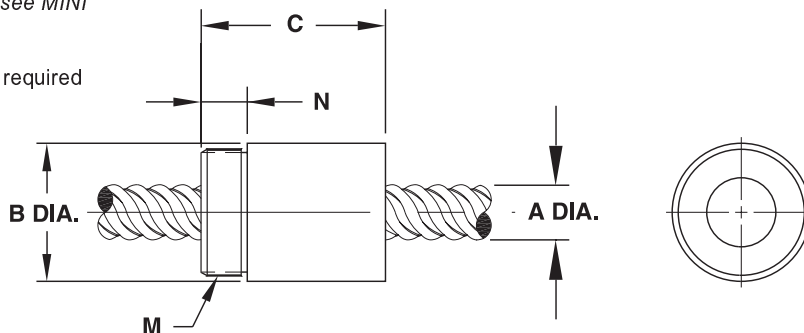

FREE-WHEELING
and SPECIALTY NUTS

MINI Series – miniature style assemblies, with or without “anti-backlash” function

The Kerk® MINI Series brings Haydon Kerk Motion Solutions quality, precision and value to products that were previously off limits to leadscrew technology. To meet a wide range of applications, the MINI Series includes anti-backlash and standard assemblies.

- Using a patented take-up mechanism, the self-compensating **NTB** maintains axial stiffness throughout its life while system torque is held to a minimum.
- The **NTG** allows drag torque to be pre-set according to system requirements.
- The MINI **BFW** Series is for applications not requiring anti-backlash and wear compensation.

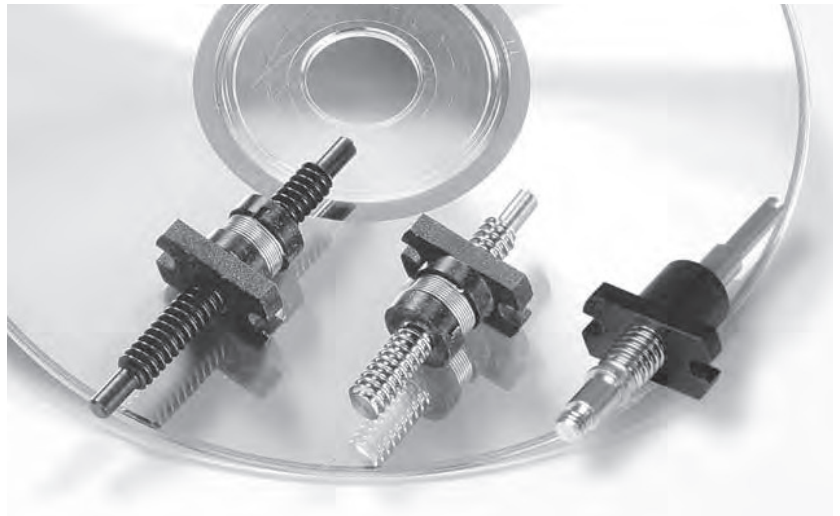

All Mini Series assemblies include 303 stainless steel lead screws, available with Haydon Kerk Motion Solutions proprietary, long-life Kerkote® TFE coating. All the nuts are maintenance free, manufactured with self-lubricating polyacetal, and designed to run smoothly and efficiently on Haydon Kerk Motion Solutions precision rolled screws. Perfect for demanding applications, the MINI NTB and NTG nuts provide zero backlash with drag torque of less than 1 oz.-in. (some sizes as low as 0.1 oz.-in.!) Kerk Mini Series Leadscrew Assemblies have what it takes for affordable, precision motion control, sized to fit and built to last.

MINI Series: Flange Mount

	Screw Diam.	Nut Diam.	Nut Length	Flange Height	Flange Width	Flange Thickness	Slot Width	Bolt Circle Diam.	Dynamic Load	Drag Torque
	A inch (mm)	B inch (mm)	C inch (mm)	D1 inch (mm)	D inch (mm)	E inch (mm)	F inch (mm)	G inch (mm)	lbs (Kg)	oz-in (NM)
BFWA Flange Mount	1/8 (3)	0.40 (10.2)	0.50 (13)	0.40 (10.2)	0.75 (19.1)	0.13 (3.2)	0.120 (3.05)	0.600 (15.24)	25 (11)	free wheeling
	3/16 (5)	0.40 (10.2)	0.50 (13)	0.40 (10.2)	0.75 (19.1)	0.13 (3.2)	0.120 (3.05)	0.600 (15.24)	25 (11)	free wheeling
NTBA Flange Mount	1/8 (3)	0.40 (10.2)	0.50 (13)	0.40 (10.2)	0.75 (19.1)	0.13 (3.2)	0.120 (3.05)	0.600 (15.24)	5 (2.3)	0.5 (.004)
	3/16 (5)	0.40 (10.2)	0.50 (13)	0.40 (10.2)	0.75 (19.1)	0.13 (3.2)	0.120 (3.05)	0.600 (15.24)	5 (2.3)	0.5 (.004)
NTGA Flange Mount	1/8 (3)	0.40 (10.2)	0.50 (13)	0.40 (10.2)	0.75 (19.1)	0.13 (3.2)	0.120 (3.05)	0.600 (15.24)	5 (2.3)	0.5 (.004)
	3/16 (5)	0.40 (10.2)	0.50 (13)	0.40 (10.2)	0.75 (19.1)	0.13 (3.2)	0.120 (3.05)	0.600 (15.24)	5 (2.3)	0.5 (.004)

For 1/4-in diameter screws and larger, please refer to the individual sections for each nut type.

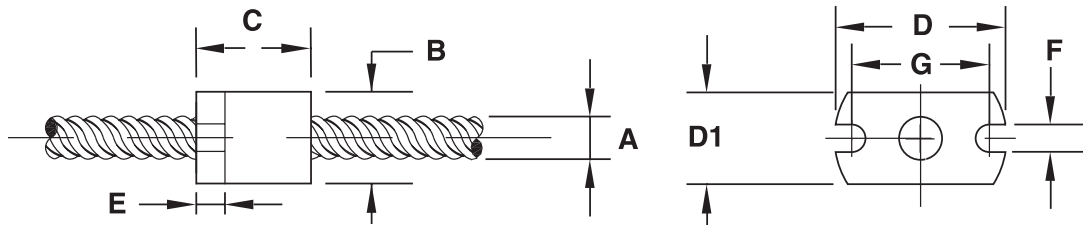

MINI Series: Thread Mount

	Screw Diam.	Nut Diam.	Nut Length	Thread	Thread Length	Dynamic Load	Drag Torque
	A inch (mm)	B inch (mm)	C inch (mm)	M* inch	N inch (mm)	lbs (Kg)	oz-in (NM)
BFWT Thread Mount	1/8 (3)	0.40 (10.2)	0.50 (13)	3/8-24	0.187 (4.75)	25 (11)	free wheeling
	3/16 (5)	0.40 (10.2)	0.50 (13)	3/8-24	0.187 (4.75)	25 (11)	free wheeling
NTBT Thread Mount	1/8 (3)	0.40 (10.2)	0.50 (13)	3/8-24	0.125 (3.18)	5 (2.3)	0.5 (.004)
	3/16 (5)	0.40 (10.2)	0.50 (13)	3/8-24	0.125 (3.18)	5 (2.3)	0.5 (.004)
NTGT Thread Mount	1/8 (3)	0.40 (10.2)	0.50 (13)	3/8-24	0.160 (4.06)	5 (2.3)	0.5 (.004)
	3/16 (5)	0.40 (10.2)	0.50 (13)	3/8-24	0.160 (4.06)	5 (2.3)	0.5 (.004)

* metric available as required

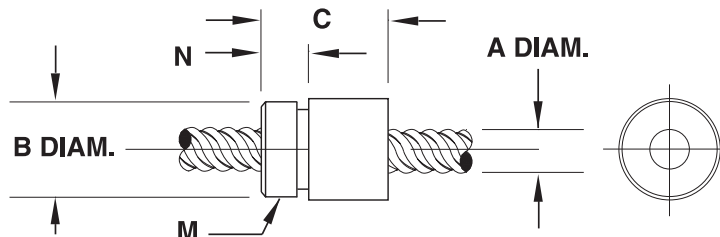



Micro Leadscrew / Nut Assemblies

Haydon Kerk Motion Solutions, recognized world-wide as a leader in linear motion, has applied their experience and knowledge of precision thread rolling to a new range of micro-sized leadscrews. Manufactured of premium grade 303 stainless steel, Kerk® Micro Series Lead Screw Assemblies provide exceptional performance, long life, and require no maintenance. High accuracy threads with superior uniformity deliver precise motion and reduce noise and vibration. Nut configurations of self-lubricating acetal and Kerkite® High Performance Composite Polymers. This remarkable product line is an enabling technology, opening up a whole new range of designs. The Micro Series allows the miniaturization of products, reduced power consumption, and weight reduction without sacrificing performance or reliability. Developed in response to growing demands in many markets, Haydon Kerk Motion Solutions has offered micro screws on a custom basis for more than 10 years. Now, available as a standard product, customers can get quicker, cost effective deliveries. The Micro Series Lead screws are available as stand-alone components or integrated into the high performance Haydon™ linear actuators.

MICRO Series LEADSCREWS

Screw Diameter	Diam. Code	Lead	Lead Code	Outside Diameter*	Root Diameter*	Efficiency % **
inch (mm)		inch (mm)		inch (mm)	inch (mm)	
5/64 (2)	008	0.012 (0.30)	0012	0.079 (2.01)	0.068 (1.73)	24
		0.016 (0.40)	0016	0.075 (1.91)	0.058 (1.47)	30
		0.020 (0.50)	0020	0.077 (1.96)	0.057 (1.45)	36
		0.039 (1.00)	0039	0.079 (2.01)	0.059 (1.50)	52
		0.079 (2.00)	0079	0.077 (1.96)	0.057 (1.45)	66

* For Reference ** Theoretical values based on *uncoated* leadscrews

MICRO Series Nut Styles

BFW Nut Style	Screw Diameter A	Nut Diameter B	Nut Length C	Nut Flats D	Dynamic Load	Drag Torque
	inch (mm)	inch (mm)	inch (mm)	inch (mm)	lbs (Kg)	oz-in. (NM)
BFWB	Barrel Mount	5/64 (2)	0.22 (5.5)	0.32 (8)	0.22 (5.5)	10 (4.5) Free Wheeling

Barrel Nut Style

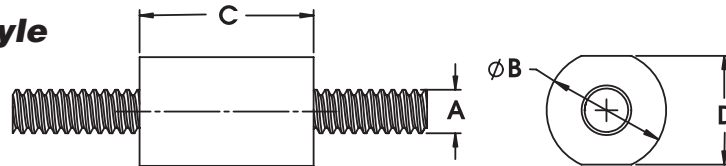

BFW Nut Style	Screw Diameter A	Nut Diameter B	Nut Length C	Flange Height D1	Flange Width D	Flange Thickness E	Slot Width F	Bolt Circle Diameter G	Dynamic Load	Drag Torque
	inch (mm)	inch (mm)	inch (mm)	inch (mm)	inch (mm)	inch (mm)	inch (mm)	inch (mm)	lbs (Kg)	oz-in. (NM)
BFWR	Rectangular Flange	5/64 (2)	0.22 (5.5)	0.32 (8)	0.22 (5.5)	0.47 (11.9)	0.08 (2.0)	0.07 (1.8)	0.35 (9.0)	10 (4.5) Free Wheeling

Rectangular Nut Style

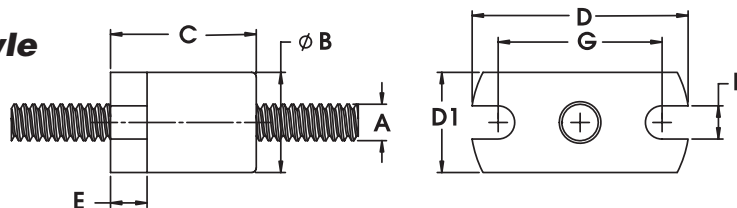

MICRO SERIES LEADSCREW & NUTS



Custom Nut Configurations

In addition to The Kerk® standard nut types, modified and complete custom configurations represent a large portion of the company's production. Modifications may be simple changes such as different mounting hole patterns or mounting threads, small dimensional changes, or special materials. Haydon Kerk Motion Solutions can provide tremendous value by producing a multi-functional nut. Using custom molds and specialty machining, nuts can also include guide bushings, carriages, timing pulleys, gears, syringe components, sensor mounts and flags, encoder features, clamps and many other complimentary elements. In addition, custom designed nuts can offer quick release mounts, partial thread engagement, half nut construction or special shapes and geometries. Special materials are offered to extend the performance of our assemblies. Materials can be chosen for extreme temperature, chemical compatibility, autoclaving, agency approvals, special loadings and many other specific requirements.

Custom nut designs can include multi-functionality, eliminating additional components to simplify product manufacturing. This can deliver both cost- and space-saving benefits.

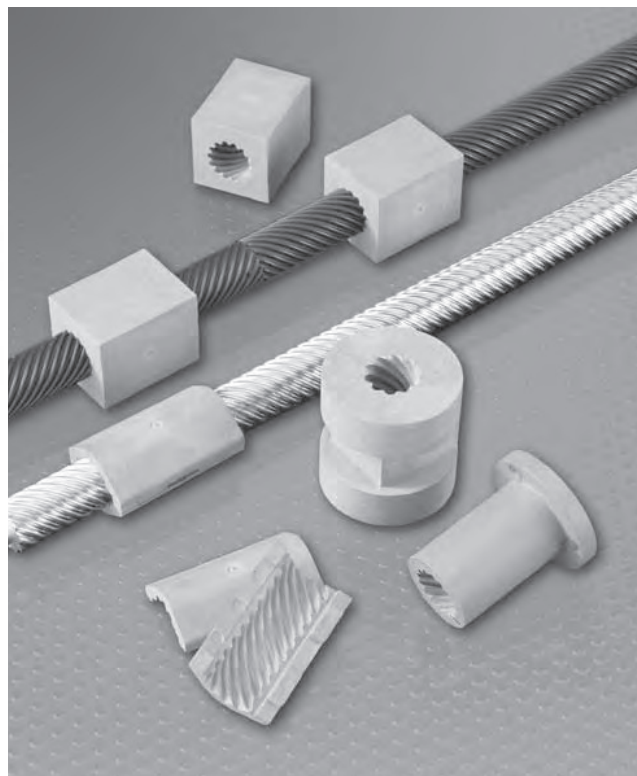

FREE-WHEELING and SPECIALTY NUTS



Custom geometries and custom materials can be combined for a wide variety of product application requirements.

