



HEIDENHAIN



Length Gauges

May 2008

Incremental length gauges from HEIDENHAIN offer high accuracy over long measuring ranges. These sturdily made gauges are available in application-oriented versions.

They have a wide range of applications in production metrology, in multipoint inspection stations, measuring equipment monitoring, and as position measuring devices.



This catalog supersedes all previous editions, which thereby become invalid. The basis for ordering from HEIDENHAIN is always the catalog edition valid when the contract is made.

Standards (ISO, EN, etc.) apply only where explicitly stated in the catalog.



Length Gauges – Applications and Products			
Range of Applications, Application Examples			4
Length Gauges from HEIDENHAIN			6
Length Gauge Overview			8
Technical Features and Mounting Information			
Principle of Function			10
Mechanical Design			11
Measuring Accuracy			12
Gauging Force and Plunger Actuation			14
Mounting			16
Specifications	<i>Accuracy</i>	<i>Measuring range</i>	
HEIDENHAIN-CERTO	± 0.1 µm; ± 0.03 µm* ± 0.1 µm; ± 0.05 µm*	25 mm 60 mm	18
HEIDENHAIN-METRO	± 0.2 µm	12 mm 25 mm	20
HEIDENHAIN-METRO	± 0.5 µm ± 1 µm	60 mm 100 mm	22
HEIDENHAIN-SPECTO	± 1 µm	12 mm 30 mm	24
Length Gauge Accessories			
Measuring Contacts, Switch Boxes, Coupling			26
Gauge Stands, Ceramic Suction Plate, Diaphragm Compressor	For HEIDENHAIN-CERTO		28
Cable-Type Lifter, Gauge Stands	For HEIDENHAIN-METRO and HEIDENHAIN-SPECTO		30
Evaluation and Display Units			
Position Display Units			32
Counter Card			35
Electrical Connection			
Interfaces	Incremental signals \sim 11 µApp		37
	Incremental signals \sim 1 V _{PP}		38
	Incremental signals \square TTL		40
Connecting Elements and Cables			42

* After linear length-error compensation in the evaluation electronics

Range of Applications In Quality Assurance

Metrology and production control

Incremental length gauges from HEIDENHAIN play a role in incoming goods inspection, fast dimension checking during production, statistical process control in production or quality assurance, or in any application where fast, reliable and accurate length measurement is required. Their large measuring lengths are a particular advantage: whether the part measures 5 mm or 95 mm, it is measured immediately with one and the same length gauge.

Whatever the application, HEIDENHAIN has the appropriate length gauge for the required accuracy. The **HEIDENHAIN-CERTO** length gauges offer a very high accuracy of $\pm 0.1 \mu\text{m}/\pm 0.05 \mu\text{m}^*/\pm 0.03 \mu\text{m}^*$ for extremely precise measurement. Length gauges from the **HEIDENHAIN-METRO** program have accuracy grades as fine as $\pm 0.2 \mu\text{m}$, while the **HEIDENHAIN-SPECTO** length gauges, with $\pm 1 \mu\text{m}$ accuracy, offer particularly compact dimensions.

* After linear length-error compensation in the evaluation electronics



Gauge block calibration and measuring device inspection

The usual inspection of measuring equipment called for by standards, and the inspection of gauge blocks in particular, necessitate a large number of reference standard blocks if the comparative measurement is performed using inductive length gauges. The problem is the small measuring range of inductive gauges: they can measure length differences of only up to $10 \mu\text{m}$. Incremental length gauges, which offer large measuring ranges together with high accuracy, greatly simplify the calibration of measuring devices required to ensure traceability.

The length gauges of the **HEIDENHAIN-CERTO** program with measuring ranges of 25 mm at $\pm 0.1 \mu\text{m}/\pm 0.03 \mu\text{m}^*$ accuracy and 60 mm at $\pm 0.1 \mu\text{m}/\pm 0.05 \mu\text{m}^*$ accuracy are especially well suited for this task. It permits a significant reduction in the required number of reference standard blocks, and recalibrating becomes much simpler.

Thickness gauging of silicon wafers



Inspection of styli

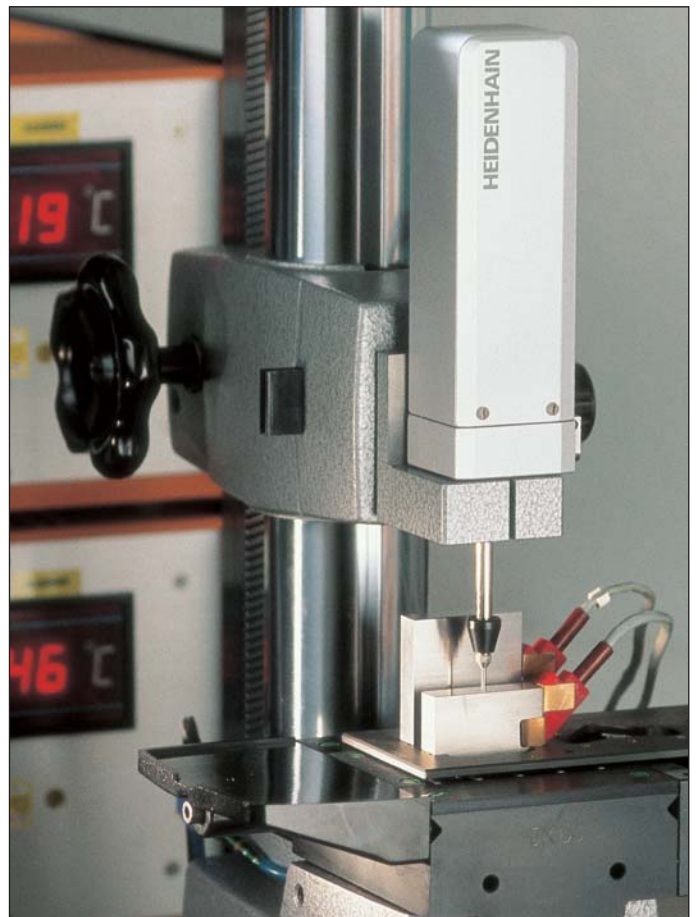

Calibration of gauge blocks

In Production

Multipoint inspection devices

Multipoint inspection devices require durable length gauges with small dimensions. They should also have relatively large measuring ranges of several millimeters with consistent linear accuracy in order to simplify the construction of inspection devices—for example by enabling the construction of one device for several masters. A large measuring length also provides benefits in master production, because simpler masters can be used.

With their small dimensions and measuring ranges of 12 mm or 30 mm and $\pm 1 \mu\text{m}$ accuracy, the **HEIDENHAIN-SPECTO** incremental length gauges are specifically designed for multipoint inspection devices. Higher accuracy requirements up to $\pm 0.2 \mu\text{m}$ can be met with similarly compact **HEIDENHAIN-METRO** length gauges.

Unlike inductive gauges, HEIDENHAIN-SPECTO length gauges provide stable measurement over long periods—eliminating recalibration.



Position capture

Incremental length gauges from HEIDENHAIN are also ideal for position measurement on precision linear slides or X-Y tables. Working with measuring microscopes, for example, becomes much easier thanks to the digital readout and the flexible datum setting.

Here, length gauges from the **HEIDENHAIN-METRO** and **HEIDENHAIN-SPECTO** program come into use with large measuring ranges of 30 mm, 60 mm or 100 mm at consistently high accuracy grades of $\pm 0.5 \mu\text{m}$ or $\pm 1 \mu\text{m}$.

In this application as linear measuring device, the length gauge's fast installation in accordance with the Abbe measuring principle by its clamping shank or planar mounting surface is of special benefit.

Testing station for flatness inspection

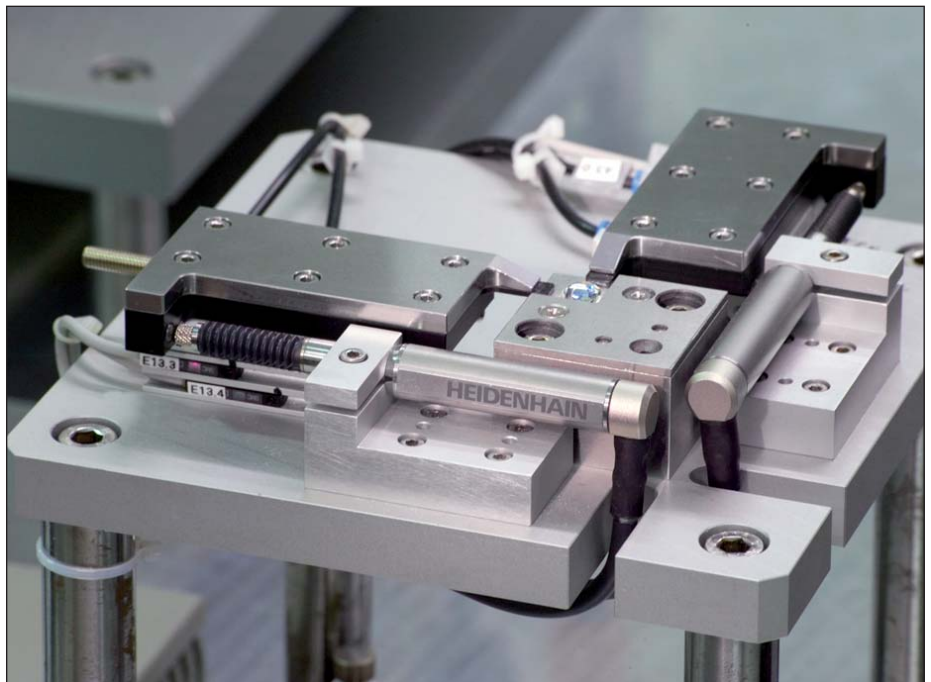

Position measurement on an X-Y table for lens mounting

Tolerance gauging of semifinished products

Length Gauges from HEIDENHAIN

A number of arguments speak for HEIDENHAIN length gauges. These include not only their technical features, but also their high quality standard and the worldwide presence of HEIDENHAIN.

Large measuring ranges

HEIDENHAIN length gauges are available with measuring lengths of 12 mm, 25 mm, 30 mm, 60 mm or 100 mm so that you can measure very different parts in one measuring setup and avoid frequently changing setups with expensive gauge blocks or masters.

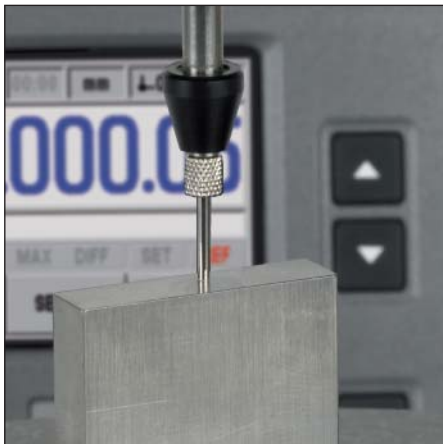

High accuracy

The high accuracy specified for HEIDENHAIN length gauges applies over the entire measuring length. Whether the part measures 10 or 100 mm, its actual dimension is always measured with the same high quality. The high repeatability of HEIDENHAIN length gauges comes into play during comparative measurements, for example in series production.



Robust design

HEIDENHAIN length gauges are built for an industrial environment. They feature consistently high accuracy over a long period of time as well as high thermal stability. They can therefore be used in production equipment and machines.

Wide range of applications

HEIDENHAIN length gauges are suited for many applications. Automatic inspection equipment, manual measuring stations or positioning equipment—wherever lengths, spacing, thickness, height or linear motion are to be measured, HEIDENHAIN length gauges function quickly, reliably and accurately.



Know-how

The high quality of HEIDENHAIN length gauges is no coincidence. HEIDENHAIN has been manufacturing high-accuracy scales for over 70 years, and for many years it has developed measuring and testing devices for length and angle laboratories. This know-how makes HEIDENHAIN an extraordinarily qualified partner for metrological questions.

Worldwide presence

HEIDENHAIN is represented in all important industrial countries—in most of them with wholly owned subsidiaries. Sales engineers and service technicians support the user on-site with technical information and servicing in the local language.



Length Gauge Overview



MT 101



MT 60



ST 3000



ST 1200

Accuracy	Measuring range
$\pm 0.1 \mu\text{m}$ $\pm 0.05 \mu\text{m}$ ^{*)} $\pm 0.03 \mu\text{m}$ ^{*)}	HEIDENHAIN-CERTO Plunger actuation by motor Motor-driven or by external coupling
$\pm 0.2 \mu\text{m}$	HEIDENHAIN-METRO Plunger actuation by cable lifter or measured object Pneumatic plunger actuation
$\pm 0.5 \mu\text{m}$ $\pm 1 \mu\text{m}$	HEIDENHAIN-METRO Plunger actuation by motor Motor-driven or by external coupling
$\pm 1 \mu\text{m}$	HEIDENHAIN-SPECTO Plunger actuation by measured object Pneumatic plunger actuation

^{*)} After linear length-error compensation in the evaluation electronics

12 mm	25 mm/30 mm	60 mm	100 mm	Page
				18
	CT 2501 $\sim 11 \mu\text{A}_{\text{PP}}$ CT 2502 $\sim 11 \mu\text{A}_{\text{PP}}$	CT 6001 $\sim 11 \mu\text{A}_{\text{PP}}$ CT 6002 $\sim 11 \mu\text{A}_{\text{PP}}$		
MT 1271 $\square\text{TTTL}$ MT 1281 $\sim 1 \text{V}_{\text{PP}}$ MT 1287 $\sim 1 \text{V}_{\text{PP}}$	MT 2571 $\square\text{TTTL}$ MT 2581 $\sim 1 \text{V}_{\text{PP}}$ MT 2587 $\sim 1 \text{V}_{\text{PP}}$			20
		MT 60M $\sim 11 \mu\text{A}_{\text{PP}}$ MT 60K $\sim 11 \mu\text{A}_{\text{PP}}$	MT 101M $\sim 11 \mu\text{A}_{\text{PP}}$ MT 101K $\sim 11 \mu\text{A}_{\text{PP}}$	22
ST 1278 $\square\text{TTTL}$ ST 1288 $\sim 1 \text{V}_{\text{PP}}$ ST 1277 $\square\text{TTTL}$ ST 1287 $\sim 1 \text{V}_{\text{PP}}$	ST 3078 $\square\text{TTTL}$ ST 3088 $\sim 1 \text{V}_{\text{PP}}$ ST 3077 $\square\text{TTTL}$ ST 3087 $\sim 1 \text{V}_{\text{PP}}$			24



CT 6000



CT 2500



MT 2500



MT 1200

Principle of Function

HEIDENHAIN length gauges are characterized by long measuring ranges and consistently high accuracy. The basis for both is the measuring principle of photoelectrically scanning an incremental scale.

HEIDENHAIN linear encoders use material measuring standards consisting of **incremental graduations** on substrates of glass or glass ceramic. These measuring standards permit large measuring ranges, are insensitive to vibration and shock, and have a defined thermal behavior. Changes in atmospheric pressure or relative humidity have no influence on the accuracy of the measuring standard—which is the prerequisite for the **high long-term stability** of HEIDENHAIN length gauges.

The masters for these graduations are fabricated on dividing engines developed and built by HEIDENHAIN. High thermal stability during the manufacturing process ensures that the graduations have **high accuracy** over the measuring length. The master graduation is applied to the carrier using the DIADUR copying process developed by HEIDENHAIN, which produces very thin but durable graduation structures of chromium.

The incremental graduation is **photoelectrically scanned** without mechanical contact and therefore without wear. Light passes through the structured scanning reticle and over the scale onto photo-voltaic cells. The photovoltaic cells produce sinusoidal output signals with a small signal period. Interpolation in the subsequent electronics makes very small measuring steps into the nanometer range possible. The scanning principle, together with the extremely fine graduation lines and their high edge definition ensure the quality of the output signals as well as the **small position error within one signal period**. This applies particularly to HEIDENHAIN length gauges, which use a DIADUR phase grating as measuring standard. The interferential scanning method produces sinusoidal incremental signals with a period of only 2 μm .

Reference mark

Photoelectric scanning of grid structures results in an incremental, i.e. counting, measurement. To ascertain positions, an absolute reference is required. The reference mark enables the exact reestablishment of the most recently defined datum, for example after an interruption in power. It is photoelectrically scanned and is permanently associated with exactly one measuring step, regardless of the direction or velocity of traverse.

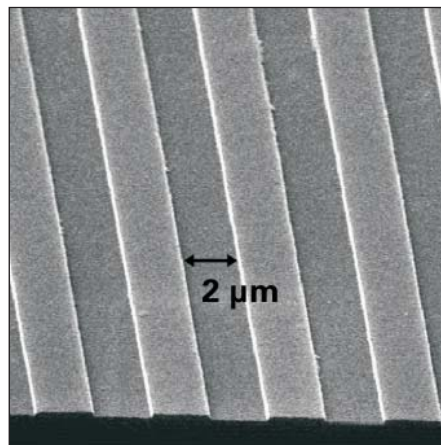
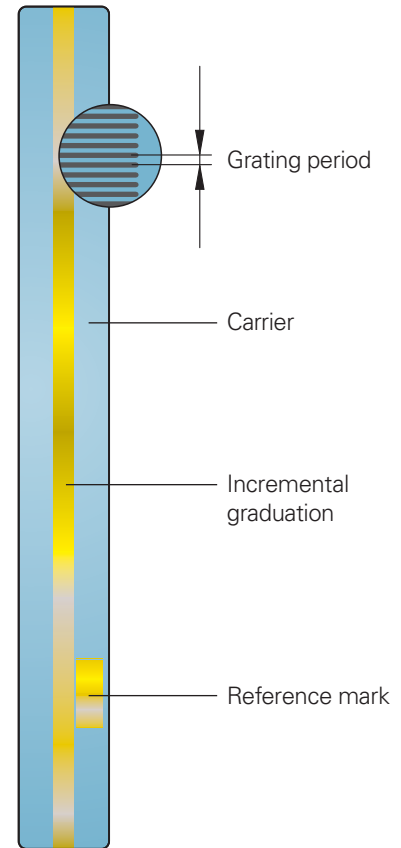

DIADUR phase grating with approx. 0.25 μm grating height

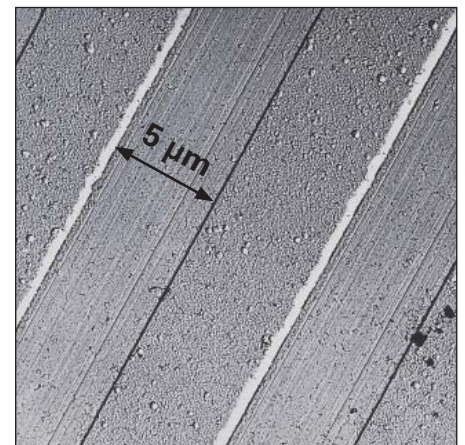

DIADUR scale

Mechanical Design

HEIDENHAIN length gauges function according to the **Abbe measuring principle**, i.e. the measuring standard and the plunger are exactly aligned. All components comprising the **measuring loop**, such as the measuring standard, plunger, holder and scanning head are designed in terms of their mechanical and thermal stability for the highest possible accuracy of the length gauge.

HEIDENHAIN length gauges have a defined **thermal behavior**. Since temperature variations during measurement can result in changes in the measuring loop, HEIDENHAIN uses special materials with low α_{therm} coefficients of expansion for the components of the measuring loop, for example in the CERTO length gauges. The scale is manufactured of Zerodur[®] ($\alpha_{\text{therm}} \approx 0 \text{ K}^{-1}$), and the plunger and holder are of Invar ($\alpha_{\text{therm}} \approx 1 \cdot 10^{-6} \text{ K}^{-1}$). This makes it possible to guarantee its high measuring accuracy over a relatively large temperature range.

Length gauges from HEIDENHAIN have a **sturdy design**. Even high vibration and shock loads have no negative influence on the accuracy.

The **ball-bush guided plunger** tolerates high radial forces and moves with very low friction. It has an M2.5 thread to hold measuring contacts.

Parts subject to wear

HEIDENHAIN length gauges contain components that are subject to wear, depending on the application and manipulation. These include in particular the following parts:

- LED light source
- Guideway (tested for at least 5 million strokes*)
- Cable link for CT, MT 60 and MT 101 (tested for at least 1 million strokes*)
- Scraper rings
- Rubber bellows on ST 1200

* On CT, MT 60M and MT 101 M only with actuation by switch box

DIADUR is a registered trademark of DR. JOHANNES HEIDENHAIN GmbH, Traunreut, Germany.
Zerodur[®] is a registered trademark of Schott-Glaswerke, Mainz, Germany.

Design of ST 1200

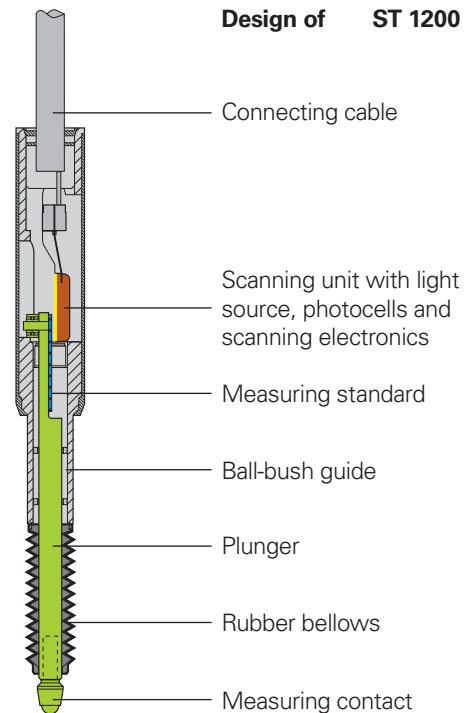

Design of CT 6000 MT 60

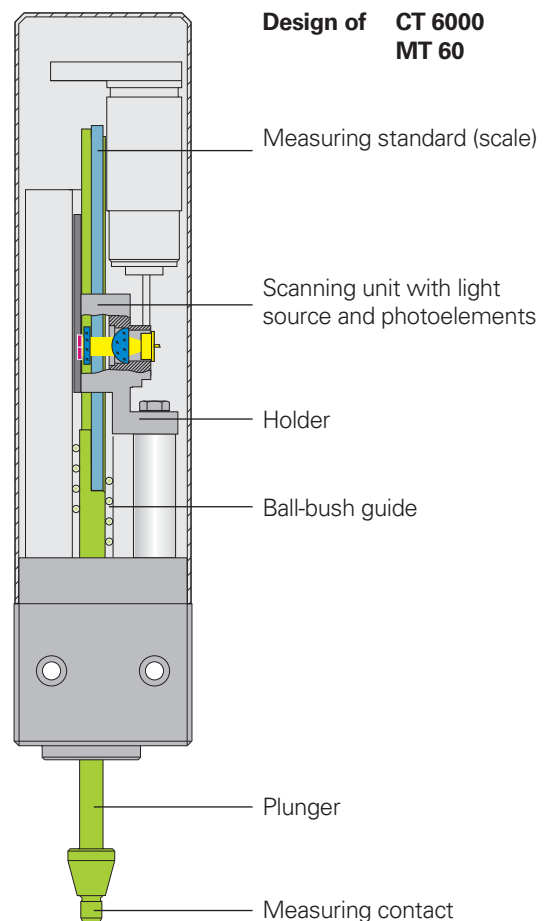

Measuring Accuracy

The accuracy of position measurement with length gauges is mainly determined by the following factors:

- The quality of the graduation
- The quality of the scanning process
- The quality of the signal processing electronics
- The error from the scale guideway relative to the scanning unit

A distinction is made between position error over relatively large paths of traverse—for example the entire measuring range—and that within one signal period.

Position error over the measuring range

Length gauge accuracy is specified as system accuracy, which is defined as follows:

*The extreme values of the **total error F**—with reference to their mean value—lie over the entire measuring length within the system accuracy $\pm a$. They are measured during the final inspection and documented in the calibration chart.*

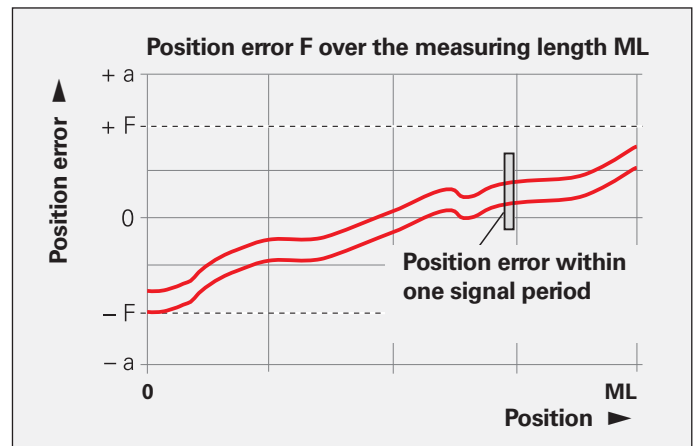

Position error within one signal period

The **position error u** within one signal period is determined by the signal period of the length gauge, as well as the quality of the graduation and its scanning. At any position over the entire measuring length, it does not exceed approx. $\pm 1\%$ of the signal period.

The smaller the signal period, the smaller the position error within one signal period. In the calibration chart of the HEIDENHAIN-CERTO, this position error within one signal period is shown as a tolerance band.

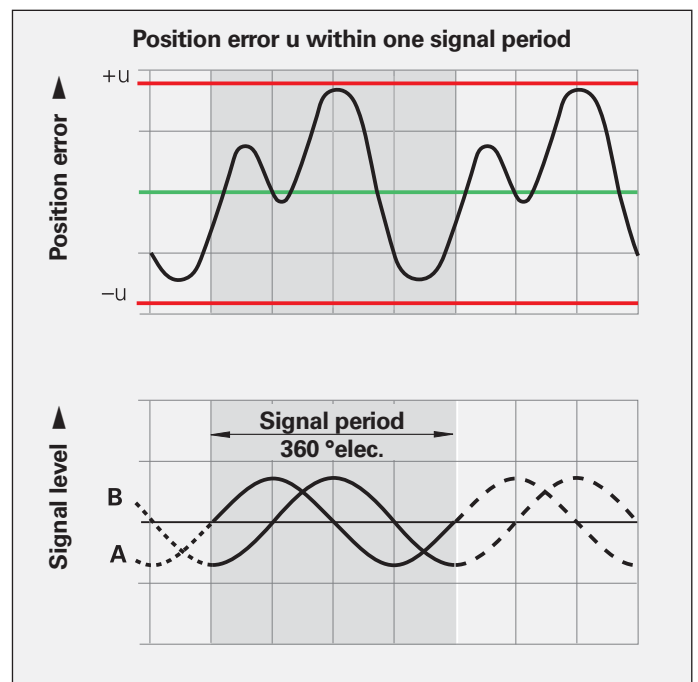

	Signal period of the scanning signals	Max. position error u within one signal period
CT 2500 CT 6000	2 μm	Approx. $\pm 0.02 \mu\text{m}$
MT 1200 MT 2500	2 μm	Approx. $\pm 0.02 \mu\text{m}$
MT 60 MT 101	10 μm	Approx. $\pm 0.1 \mu\text{m}$
ST 1200 ST 3000	20 μm	Approx. $\pm 0.2 \mu\text{m}$

All HEIDENHAIN length gauges are inspected before shipping for accuracy and proper function.

They are calibrated for accuracy during retraction and extension of the plunger. For the HEIDENHAIN-CERTO, the number of measuring positions is selected to ascertain very exactly not only the long-range error, but also the position error within one signal period.

The **Manufacturer's Inspection Certificate** confirms the specified system accuracy of each length gauge. The **calibration standards** ensure the traceability—as required by EN ISO 9001—to recognized national or international standards.

For the HEIDENHAIN-METRO and HEIDENHAIN CERTO series, a **calibration chart** documents the position error over the measuring range. It also shows the measuring step and the measuring uncertainty of the calibration measurement.

For the HEIDENHAIN-METRO the calibration chart shows the mean value of one forward and one backward measuring stroke.

The HEIDENHAIN-CERTO is represented in the calibration chart as the envelope curve of the measured error. The HEIDENHAIN-CERTO length gauges are supplied with two calibration charts, each for different operating attitudes.

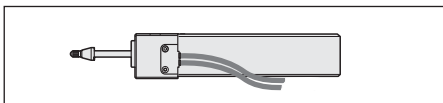

Operating attitude for calibration chart 1

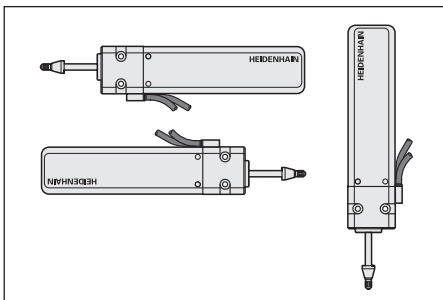

Operating attitude for calibration chart 2



HEIDENHAIN

Qualitätsprüf-Zertifikat
DIN 55 350-18-4.2.2

Quality Inspection Certificate
DIN 55 350-18-4.2.2

MT 2587
ID 372495-01
SN 2183572 D

Positionsabweichung F [µm]
Position error F [µm]

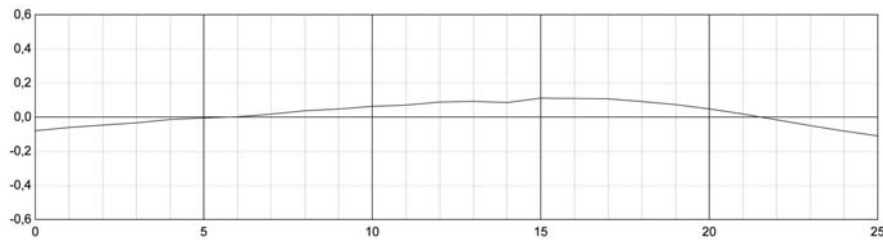

Messposition Pos_m [mm]
Measured position Pos_m [mm]

Die Messkurve zeigt die Mittelwerte der Positionsabweichungen aus Vorwärts- und Rückwärtsmessung. The error curve shows the mean values of the position errors from measurements in forward and backward direction.

Positionsabweichung F des Längenmessgerätes: $F = Pos_m - Pos_e$
Pos_m = Messposition der Messmaschine
Pos_e = Messposition des Längenmessgerätes
Position error F of the linear encoder: $F = Pos_m - Pos_e$
Pos_m = position measured by the measuring machine
Pos_e = position measured by the linear encoder

<p>Maximale Positionsabweichung der Messkurve innerhalb 25 mm</p>	<p>Maximum position error of the error curve within 25 mm</p>
± 0,11 µm	± 0,11 µm

<p>Unsicherheit der Messmaschine $U_{95\%} = 0,03 \mu\text{m} + 0,06 \cdot 10^{-4} \cdot L$ (L = Länge Messintervall)</p>	<p>Uncertainty of measuring machine $U_{95\%} = 0,03 \mu\text{m} + 0,06 \cdot 10^{-4} \cdot L$ (L = measurement interval length)</p>
---	--

<p>Messparameter</p> <table border="1" style="width: 100%; border-collapse: collapse;"> <tr><td>Messschritt</td><td>1000 µm</td></tr> <tr><td>Erster Referenzimpuls bei Messposition</td><td>23 mm</td></tr> <tr><td>Relative Luftfeuchtigkeit</td><td>max. 50 %</td></tr> </table>	Messschritt	1000 µm	Erster Referenzimpuls bei Messposition	23 mm	Relative Luftfeuchtigkeit	max. 50 %	<p>Measurement parameters</p> <table border="1" style="width: 100%; border-collapse: collapse;"> <tr><td>Measurement step</td><td>1000 µm</td></tr> <tr><td>First reference pulse at measured position</td><td>23 mm</td></tr> <tr><td>Relative humidity</td><td>max. 50 %</td></tr> </table>	Measurement step	1000 µm	First reference pulse at measured position	23 mm	Relative humidity	max. 50 %
Messschritt	1000 µm												
Erster Referenzimpuls bei Messposition	23 mm												
Relative Luftfeuchtigkeit	max. 50 %												
Measurement step	1000 µm												
First reference pulse at measured position	23 mm												
Relative humidity	max. 50 %												

Dieses Längenmessgerät wurde unter strengen HEIDENHAIN-Qualitätsnormen hergestellt und geprüft. Die Positionsabweichung liegt bei einer Bezugstemperatur von 20 °C innerhalb der Genauigkeitsklasse ± 0,2 µm. This linear encoder has been manufactured and inspected in accordance with the stringent quality standards of HEIDENHAIN. The position error at a reference temperature of 20 °C lies within the accuracy grade ± 0,2 µm.

<p>Kalibriernormale</p> <table border="1" style="width: 100%; border-collapse: collapse;"> <tr><td>Jod-stablisierter He-Ne Laser</td><td>3659 PTB 02</td></tr> <tr><td>Wasser-Tripelpunktzelle</td><td>66 PTB 05</td></tr> <tr><td>Gallium-Schmelzpunktzelle</td><td>67 PTB 05</td></tr> <tr><td>Barometer</td><td>4945 DKD-K-02301 05-09</td></tr> <tr><td>Luftfeuchtemessgerät</td><td>01758 DKD-K-00305 05-05</td></tr> </table>	Jod-stablisierter He-Ne Laser	3659 PTB 02	Wasser-Tripelpunktzelle	66 PTB 05	Gallium-Schmelzpunktzelle	67 PTB 05	Barometer	4945 DKD-K-02301 05-09	Luftfeuchtemessgerät	01758 DKD-K-00305 05-05	<p>Calibration standards</p> <table border="1" style="width: 100%; border-collapse: collapse;"> <tr><td>Iodine-stabilized He-Ne Laser</td><td>3659 PTB 02</td></tr> <tr><td>Water triple point cell</td><td>66 PTB 05</td></tr> <tr><td>Gallium melting point cell</td><td>67 PTB 05</td></tr> <tr><td>Pressure gauge</td><td>4945 DKD-K-02301 05-09</td></tr> <tr><td>Hygrometer</td><td>01758 DKD-K-00305 05-05</td></tr> </table>	Iodine-stabilized He-Ne Laser	3659 PTB 02	Water triple point cell	66 PTB 05	Gallium melting point cell	67 PTB 05	Pressure gauge	4945 DKD-K-02301 05-09	Hygrometer	01758 DKD-K-00305 05-05
Jod-stablisierter He-Ne Laser	3659 PTB 02																				
Wasser-Tripelpunktzelle	66 PTB 05																				
Gallium-Schmelzpunktzelle	67 PTB 05																				
Barometer	4945 DKD-K-02301 05-09																				
Luftfeuchtemessgerät	01758 DKD-K-00305 05-05																				
Iodine-stabilized He-Ne Laser	3659 PTB 02																				
Water triple point cell	66 PTB 05																				
Gallium melting point cell	67 PTB 05																				
Pressure gauge	4945 DKD-K-02301 05-09																				
Hygrometer	01758 DKD-K-00305 05-05																				

20.12.2007
Prüfer/Inspected by H. Gawron

DR. JOHANNES HEIDENHAIN GmbH · 83301 Traunreut, Germany · www.heidenhain.de · Telefon: +49 (8669) 31-0 · Fax: +49 (8669) 5061

Example

Temperature range

The length gauges are inspected at a **reference temperature** of 20 °C. The system accuracy given in the calibration chart applies at this temperature. The **operating temperature range** indicates the ambient temperature limits between which the length gauges will function properly. The **storage temperature range** of -20 °C to 60 °C applies for the unit in its packaging.

Gauging Force—Plunger Actuation

Gauging force

Gauging force is the force that the plunger exercises on the measured object. An excessively large gauging force can cause deformation of the measuring contact and the measured object. If the gauging force is too small, an existing dust film or other obstacle may prevent the plunger from fully contacting the measured object. The gauging force depends on the type of plunger actuation.

Plunger actuation by spring

For the MT 12x1, MT 25x1, ST 12x8 and ST 30x8, the integral spring extends the plunger to the measuring position and applies the **gauging force**. In its resting position, the plunger is extended. The gauging force depends on:

- The operating attitude
- The plunger position, because the gauging force changes over the measuring range
- The measuring direction, i.e., whether the gauge measures with extending or retracting plunger

There are several ways of actuating the length gauge plunger:

Plunger actuation by cable-type lifter

Through a cable mechanism, the plunger is retracted by hand and then extended onto the measured object. The measurement is made with extending plunger.

Plunger actuation by measured object

The complete length gauge is moved relative to the measured object. The measurement is made with retracting plunger.

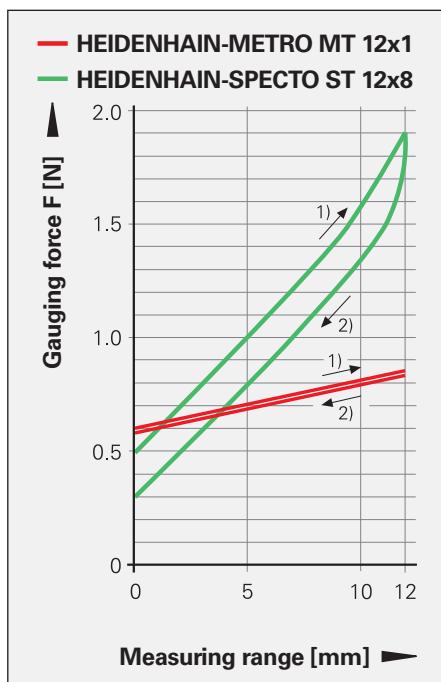

- 1) Plunger retraction
 2) Plunger extension

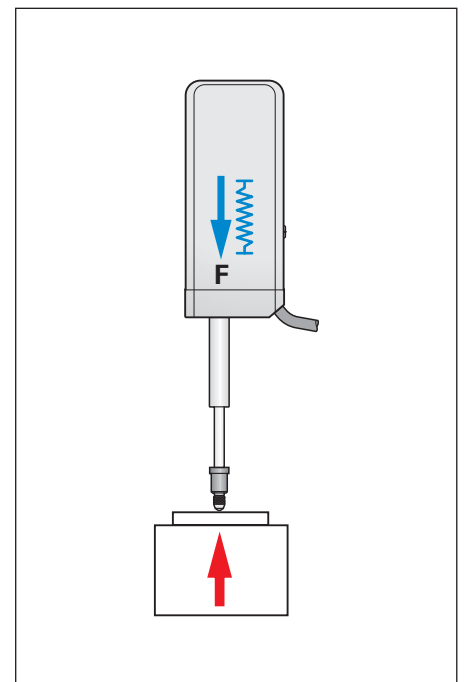
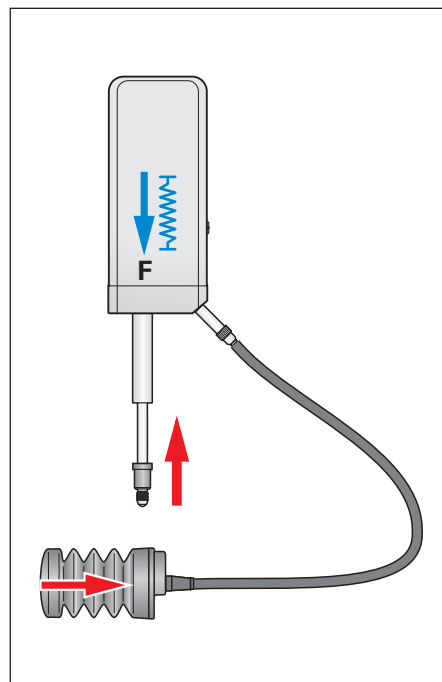

Pneumatic plunger actuation

The pneumatically actuated plungers of the MT 1287, MT 2587, ST 12x7 and ST 30x7 length gauges are extended by the application of compressed air. When the air connection is ventilated, the integral spring retracts the plunger to a protected resting position within the housing.

The **gauging force** can be adjusted to the measuring task through the level of air pressure. At constant pressure, it depends on the operating attitude and the plunger position. The vertically downward position with retracted plunger, for example, has the greatest gauging force, and the vertically upward position with extended plunger the lowest. The data given in the specifications are approximate and are subject to variation due to tolerances and to wear in the seal.

The length gauges with pneumatic plunger actuation are particularly well suited for automated measuring systems.

Motorized plunger actuation

The CT 2501, CT 6001, MT 60M and MT 101 M length gauges feature an integral motor that moves the plunger. It is operated through the switch box either by push button or over the connection for external operation. The plungers of the CT 2501, CT 6001, and MT 60M length gauges must not be moved by hand if the switch box is connected.

The **gauging force** of the CT 2501, CT 6001, and MT 60M motorized length gauges is adjustable in three stages through the switch box. The force remains constant over the measuring range but depends on the operating attitude. Regardless of the operating attitude—whether it measures vertically downward (with the SG 101V switchbox) or horizontally (with the SG 101 H switch box)—the MT 101 M exercises a constant gauging force.

Switch box and power adapter (only with MT101 M) must be ordered separately.

External plunger actuation by coupling

For the CT 2502, CT 6002, MT 60K, MT 101 K and special versions “without spring” of the MT 1200 and MT 2500, the plunger is freely movable. For position measurement, the plunger is connected by a coupling with a moving machine element. The force needed to move the plunger is specified as the required **moving force**. It depends on the operating attitude.

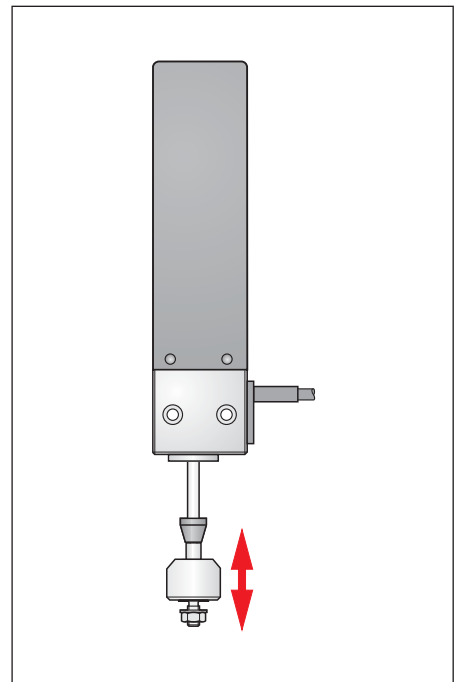
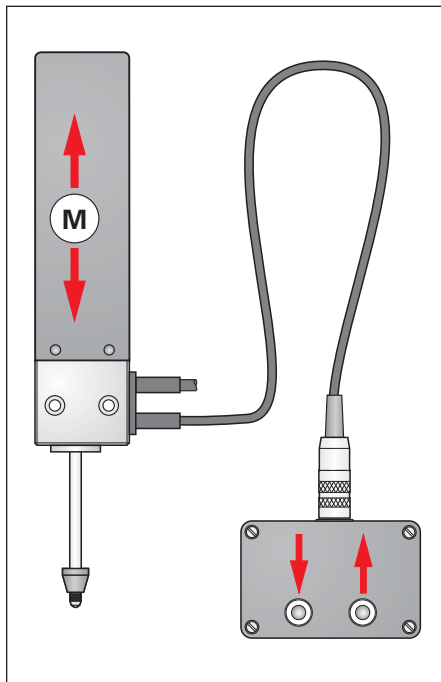
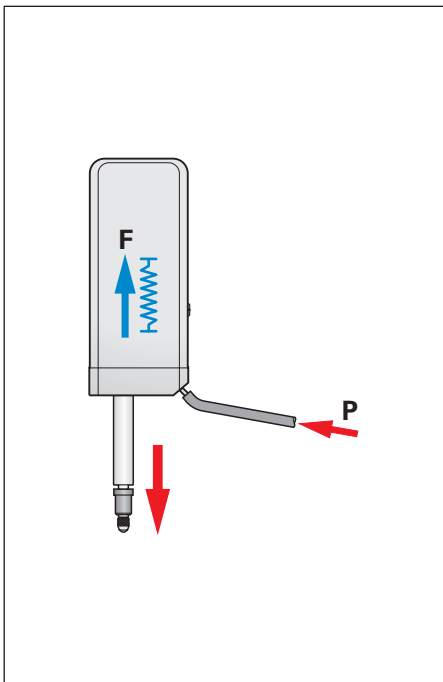

Mounting

In addition to the length gauge itself, the mechanical design of the measuring setup also plays a role in defining the quality of measurement.

Abbe principle

HEIDENHAIN length gauges enable you to work according to the Abbe measuring principle: The measured object and scale must be in alignment to avoid additional measuring error.

Measuring loop

All components included in the measuring loop such as the holder for the measured object, the gauge stand with holder, and the length gauge itself influence the result of measurement. Expansion or deformation of the measuring setup through mechanical or thermal influences adds directly to the error.

Mechanical Design

A stable measuring setup must be ensured. Long lateral elements within the measuring loop are to be avoided. HEIDENHAIN offers a stable gauge stand as an accessory. The force resulting from the measurement must not cause any measurable deformation of the measuring loop. Incremental length gauges from HEIDENHAIN operate with small gauging force and have very little influence on the measuring setup.

Thermal behavior

Temperature variations during measurement cause changes in length or deformation of the measuring setup. After a change in temperature of 5 K, a steel bar of 200 mm length expands by 10 μm .

Length changes resulting from a uniform deviation from the reference temperature can largely be compensated by resetting the datum on the measuring plate or a master; only the expansion of the scale and measured object go into the result of measurement. Temperature changes during measurement cannot be ascertained mathematically.

For critical components, HEIDENHAIN therefore uses special materials with low coefficients of expansion, such as are found in the HEIDENHAIN-CERTO gauge stand. This makes it possible to guarantee the high accuracy of HEIDENHAIN-CERTO even at ambient temperatures of 19 °C to 21 °C and variations of ± 0.1 K during measurement.

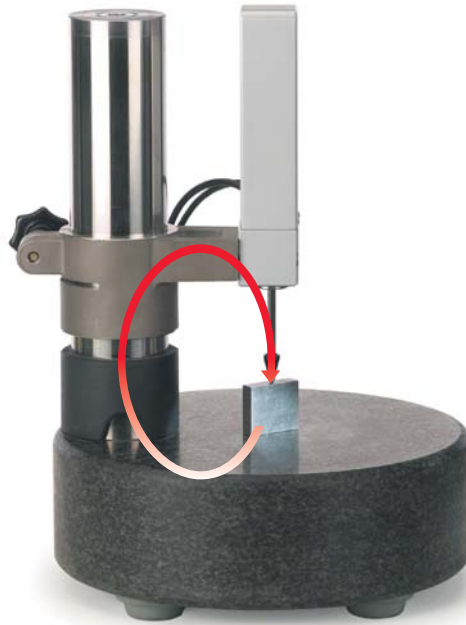

The measuring loop:

All components involved in the measuring assembly, including the length gauge

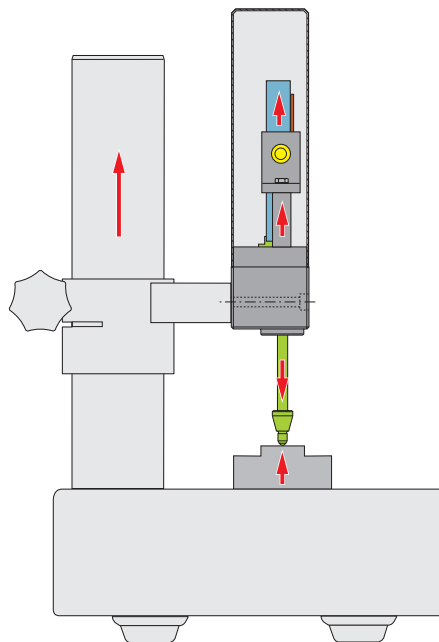

Thermally induced length change

Expansion of the measuring loop components as a result of heat

Acceleration

Shock and vibration of any kind is to be avoided during measurement so as not to impair the high accuracy of the length gauge.

The maximum values given in the specifications apply to the effect of external acceleration on the length gauge. They describe only the mechanical stability of the length gauge, and imply no guarantee of function or accuracy.

In the length gauge itself, unchecked extension of the spring-driven or non-coupled moving plunger can cause high acceleration onto the measured object or measuring plate surface. For the MT 1200 and MT 2500 series length gauges, use the cable-type lifter whenever possible (see *Accessories*). The cable lifter features adjustable pneumatic damping to limit the extension velocity to a non-critical value.

Fastening

The **CT 6000**, **MT 60** and **MT 101** length gauges are fastened by two screws onto a plane surface. This ensures a mechanically stable installation of even these large length gauges. Special holders are available for fastening the MT 60 and MT 101 to the MS 100 gauge stand for the HEIDENHAIN-METRO (see *Accessories*).

The **CT 2500** is mounted by its standard clamping shank with 16h8 diameter. A holder is available for fastening the HEIDENHAIN-CERTO to the gauge stand (see *Accessories*).

The **ST**, **MT 1200** and **MT 2500** length gauges feature a standard clamping shank with 8h6 diameter. These HEIDENHAIN length gauges can therefore easily be used with existing measuring fixtures and stands.

As an accessory, HEIDENHAIN offers a special clamping sleeve and screw. It facilitates fastening the length gauge securely without overstressing the clamping shank.

Clamping sleeve ID 386811-01

Operating attitude of HEIDENHAIN-CERTO

The HEIDENHAIN-CERTO can be operated at any attitude. However, the mounting position with horizontal length gauge and upward facing mounting surface should be avoided because in such a case no guarantee can be made for accuracy.

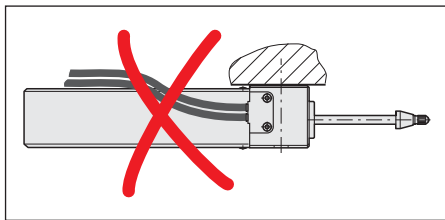

Orthogonal mounting

The length gauge is to be mounted so that its plunger is exactly orthogonal to the measured object or the surface on which it rests. Deviations result in error.

The accessory HEIDENHAIN gauge stands with holders for an **8 mm clamping shank** ensure orthogonal mounting. Length gauges that provide **planar mounting surfaces** are to be adjusted in the direction parallel to the mounting surface (Y) to be perpendicular to the measuring plate. A quick and reliable adjustment is possible with the aid of a gauge block or a parallel block. The perpendicularity to the measuring table (X) is already ensured by the gauge stand.

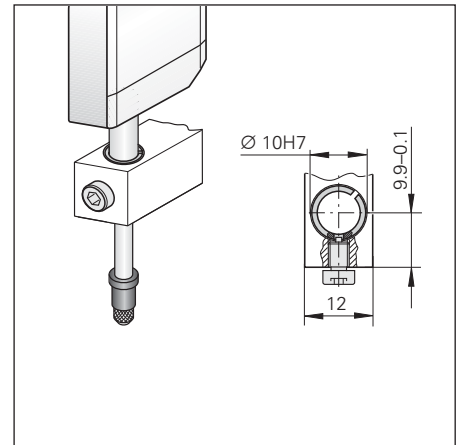
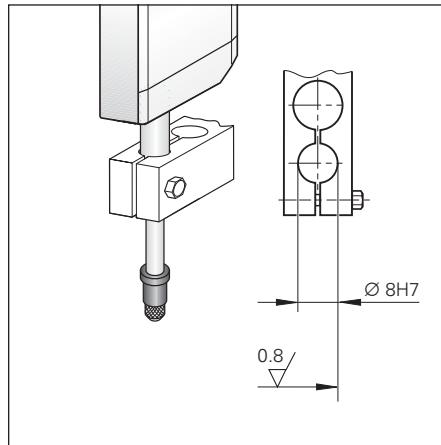
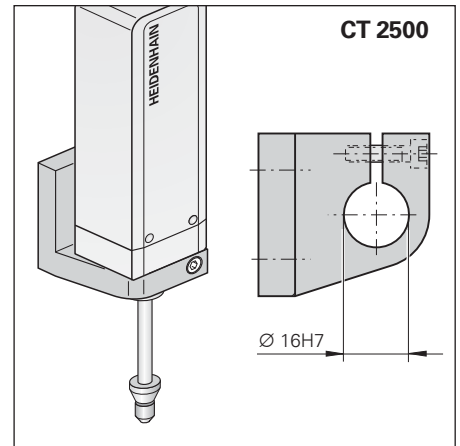
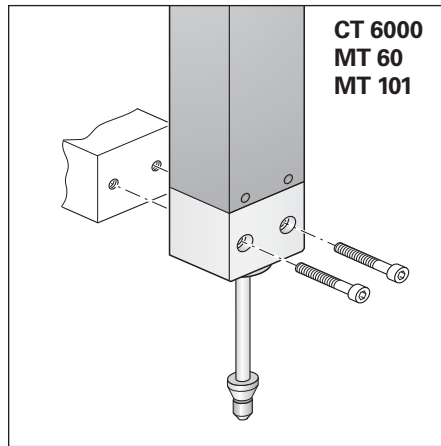

HEIDENHAIN-CERTO

Length Gauges with $\pm 0.1 \mu\text{m}/\pm 0.05 \mu\text{m}^*/\pm 0.03 \mu\text{m}^*$ Accuracy

- For very high accuracy
- For inspection of measuring equipment and gauge blocks

HEIDENHAIN-CERTO length gauges feature a large measuring range, provide high linear accuracy and offer resolution in the nanometer range. They are used predominantly for production quality control of high-precision parts and for the monitoring and calibration of reference standards. Length gauges reduce the number of working standards required to calibrate gauge blocks.

Accuracy

The total error of HEIDENHAIN-CERTO length gauges lies within $\pm 0.1 \mu\text{m}$. After linear length error compensation in the evaluation electronics of the ND 28x, for example, HEIDENHAIN guarantees accuracy of $\pm 0.03 \mu\text{m}$ for the CT 2500 and $\pm 0.05 \mu\text{m}$ for the CT 6000. These accuracy grades apply over the entire measuring range at ambient temperatures between 19 and 21 °C and with a temperature variation of $\pm 0.1 \text{ K}$ during measurements using the CS 200 gauge stand for HEIDENHAIN-CERTO.

Plunger actuation

The plungers of the **CT 2501** and **CT 6001** are extended and retracted by an integral motor. It can be actuated by the associated switch box, which can also be controlled by external signal.

CT 2502 and **CT 6002** have no plunger drive. The freely movable plunger is connected by a separate coupling with the moving machine element.

Mounting

The CT 2500 length gauge is fastened by its 16 mm diameter clamping shank. The CT 6000 is fastened with two screws on a plane surface. The CS 200 gauge stand (see *Accessories*) was conceived specially for HEIDENHAIN-CERTO length gauges. It fulfills the requirements of high precision measurement with respect to thermal behavior, stability, orthogonality and flatness of the measuring plate surface. A special holder is available as an accessory for mounting the CT 2500.

Output signals

The HEIDENHAIN-CERTO length gauges provide $\sim 11 \mu\text{A}_{\text{app}}$ current signals for HEIDENHAIN subsequent electronics.

* After linear length-error compensation in the evaluation electronics

Dimensions in mm



Tolerancing ISO 8015

ISO 2768 - m H

< 6 mm: $\pm 0.2 \text{ mm}$

⊗ = Reference mark position

CT 2500

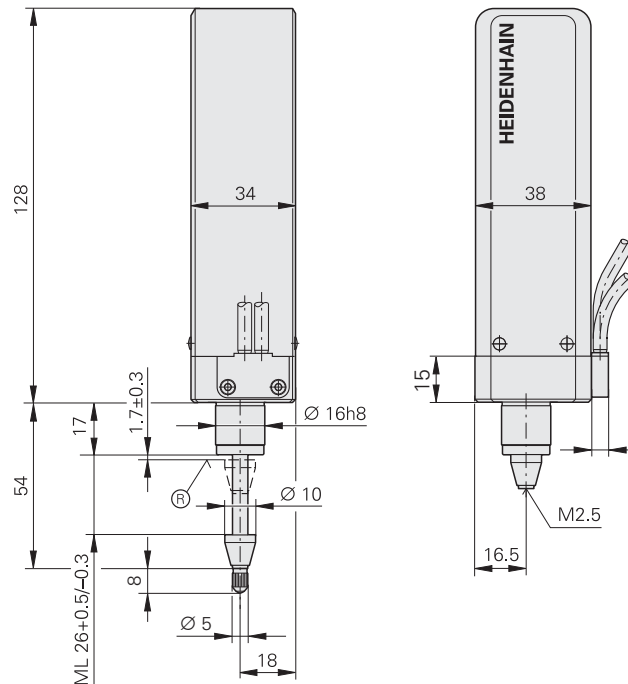

CT 6000

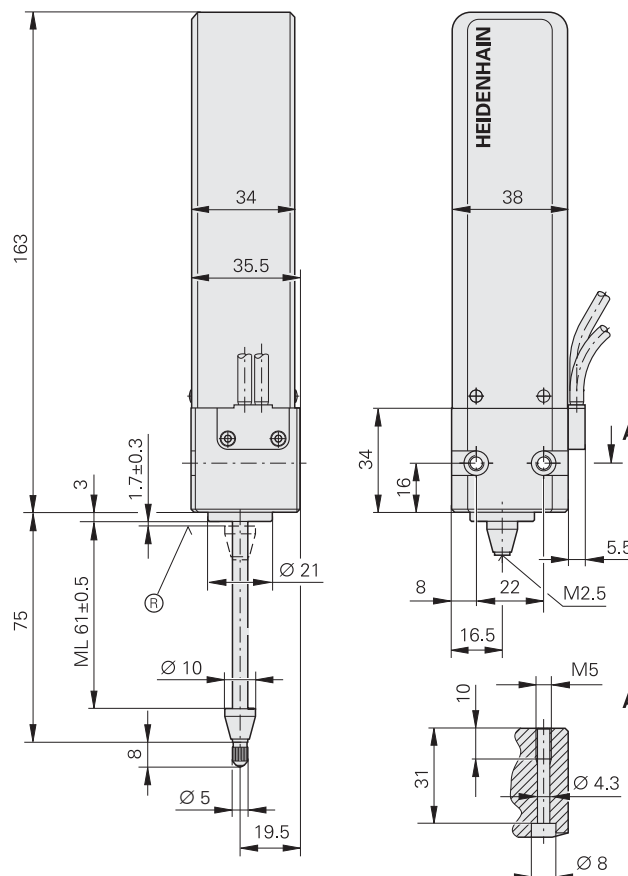

Specifications	CT 2501 CT 6001	CT 2502 CT 6002
Plunger actuation	By motor	Plunger connected via separate coupling with moving machine part
Measuring standard	DIADUR phase grating on Zerodur® glass ceramic Grating period 4 µm	
System accuracy at 19 to 21 °C <i>CT 2500</i> <i>CT 6000</i>	± 0.1 µm without compensation; ± 0.03 µm after linear length error compensation ± 0.05 µm after linear length error compensation	
Recommd. meas. step	0.01 µm/0.005 µm (5 nm) with ND 28x	
Reference mark	Approx. 1.7 mm below upper stop	
Measuring range <i>CT 2500</i> <i>CT 6000</i>	25 mm 60 mm	
Gauging force Vertically downward Vertically upward Horizontal	1 N/1.25 N/1.75 N – /– /0.75 N – /0.75 N/1.25 N	–
Required moving force	–	0.1 N to 0.6 N (depending on operating attitude)
Radial force	≤ 0.5 N (mechanically permissible)	
Operating attitude	Any required (for preferred operating attitude see page 13)	
Vibration 55 to 2000 Hz Shock 11 ms	≤ 100 m/s ² (EN 60068-2-6) ≤ 1000 m/s ² (EN 60068-2-27)	
Protection EN 60529	IP 50	
Operating temperature	10 to 40 °C; ref. temperature 20 °C	
Fastening <i>CT 2500</i> <i>CT 6000</i>	Clamping shank Ø16h8 Plane surface	
Weight <i>CT 2500</i> without cable <i>CT 6000</i>	520 g 700 g	480 g 640 g
Incremental signals	~ 11 µA _{PP} ; signal period 2 µm	
Measuring velocity	≤ 24 m/min (depending on the subsequent electronics) ≤ 12 m/min with the ND 28x display unit	
Electrical connection*	<ul style="list-style-type: none"> • Cable, 1.5 m, with 15-pin D-sub connector • Cable, 1.5 m, with 9-pin M23 connector Interface electronics are integrated in connector.	
Cable length	≤ 30 m with HEIDENHAIN cable	
Power supply	5 V ± 5 %/< 180 mA	5 V ± 5 %/< 120 mA

Required accessories*	For CT 2501	For CT 6001
Switch box	SG 25M ID 317436-01	SG 60M ID 317436-02

* Please indicate when ordering

CT 2500



CT 6000



HEIDENHAIN-METRO

Length Gauges with $\pm 0.2 \mu\text{m}$ Accuracy

- High repeatability
- Plunger actuation by cable release, by the workpiece or pneumatically

With their high system accuracy and small signal period, the HEIDENHAIN-METRO MT 1200 and MT 2500 length gauges are ideal for precision measuring stations and testing equipment. They feature ball-bush guided plungers and therefore permit high radial forces.

Plunger actuation

The length gauges of the **MT 12x1** and **MT 25x1** series feature a spring-tensioned plunger that is extended at rest. In a special version without spring it exercises particularly low force on the measured object.

In the pneumatic length gauges **MT 1287** and **MT 2587**, the plunger is retracted to its rest position by the integral spring. It is extended to the measuring position by the application of compressed air.

Mounting

The MT 1200 and MT 2500 length gauges are fastened by their 8h6 standard clamping shank. A mounting bracket is available as an accessory to mount the length gauges to plane surfaces or to the MS 200 from HEIDENHAIN.

Output signals

The MT 1200 and MT 2500 length gauges are available with various output signals. The **MT 128x** and **MT 258x** length gauges provide sinusoidal voltage signals with **1 V_{PP}** levels, which permit high interpolation. The **MT 1271** and **MT 2571** feature integrated digitizing and interpolation electronics with 5-fold or 10-fold interpolation (as ordered) and square-wave signals in **TTL** levels.

MT 1287 MT 2587

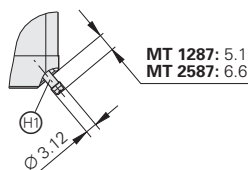

Dimensions in mm



Tolerancing ISO 8015

ISO 2768 - m H

< 6 mm: ± 0.2 mm

⊗ = Reference mark position

⊙ = Beginning of measuring length

⊕ = Air connection for 2 mm tube

MT 1200

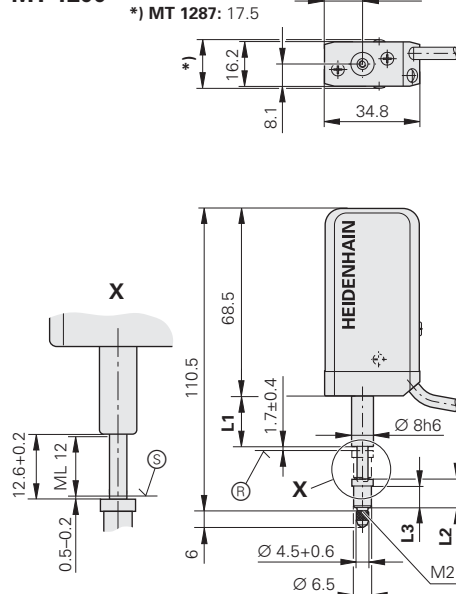

	MT 12x1	MT 1287
L1	18,5	22,0
L2	10,1	6,2
L3	8,1	4,2

MT 2500

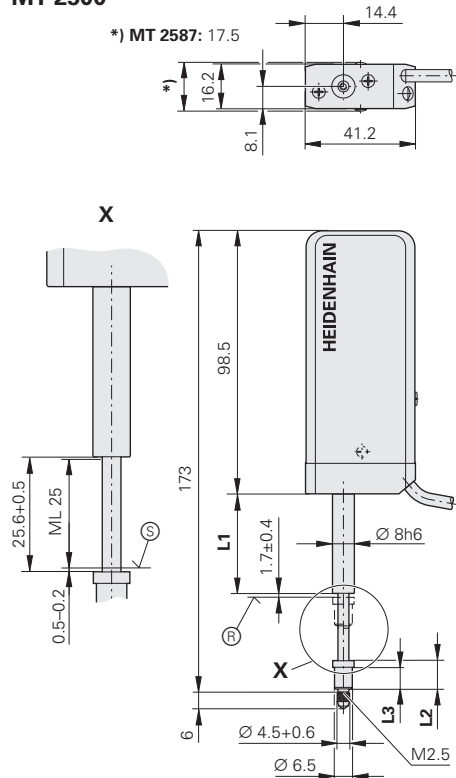

	MT 25x1	MT 2587
L1	37,0	41,0
L2	10,1	6,2
L3	8,1	4,2

Mechanical Data

Plunger actuation

Position of plunger at rest

Measuring standard

System accuracy

Reference mark

Measuring range

Gauging force¹⁾

Vertically downward

Vertically upward

Horizontal

Version "without spring"

Vertically downward

Radial force

Operating attitude

Vibration 55 to 2000 Hz

Shock 11 ms

Protection EN 60529

Operating temperature

Fastening

Weight without cable

Electrical Data

For length gauges

Incremental signals*

Signal period

Recommended measuring step

Mech. permissible traversing speed

Edge separation a at

scanning frequency*/traverse speed

200 kHz \leq 24 m/min

100 kHz \leq 12 m/min

50 kHz \leq 6 m/min







25 kHz \leq 3 m/min

Electrical connection*

Cable length





Power supply

* Please indicate when ordering

MT 1271  TTL MT 1281  1 V _{PP}		MT 2571  TTL MT 2581  1 V _{PP}		MT 1287  1 V _{PP}		MT 2587  1 V _{PP}	
By cable or measured object Extended				Pneumatic Retracted			
DIADUR phase grating on Zerodur glass ceramic; grating period 4 μm							
± 0.2 μm							
Approx. 1.7 mm below upper stop							
12 mm		25 mm		12 mm		25 mm	
0.6 to 0.85 N 0.35 to 0.6 N 0.48 to 0.73 N		0.6 N 0.28 N 0.44 N		0.2 to 0.9 N 0.2 to 0.6 N 0.2 to 0.7 N		0.2 to 1.2 N 0.2 to 0.9 N 0.2 to 1.1 N	
0.12 N		0.16 N					
≤ 0.8 N (mechanically permissible)							
Any; for version "without spring": vertically downward							
≤ 100 m/s ² (EN 60068-2-6) ≤ 1000 m/s ² (EN 60068-2-27)							
IP 50				IP 64 (with sealing air)			
10 to 40 °C; ref. temperature 20 °C							
Clamping shank Ø 8h8							
100 g		180 g		110 g		190 g	

MT 1200



 TTL MT 1271 MT 2571		 1 V _{PP} MT 128x MT 258x	
 TTL x 5 0.4 μm		 TTL x 10 0.2 μm	
0.1 μm ²⁾		0.05 μm ²⁾	
≤ 30 m/min			
≥ 0.23 μs ≥ 0.48 μs ≥ 0.98 μs –		– ≥ 0.23 μs ≥ 0.48 μs ≥ 0.98 μs	
Cable, 1.5 m, with 15-pin D-sub connector (interface electronics integrated)		Cable 1.5 m with • D-sub connector, 15-pin • M23 connector, 12 pin	
≤ 30 m with HEIDENHAIN cable			
5 V ± 5 % / < 160 mA (without load)		5 V ± 5 % / < 130 mA	

MT 2500



¹⁾ See also *Gauging Force—Plunger Actuation*

²⁾ After 4-fold evaluation

HEIDENHAIN-METRO

Length Gauges with $\pm 0.5 \mu\text{m}/\pm 1 \mu\text{m}$ Accuracy

- Large measuring ranges
- For dimensional and positional measurement

Large measuring ranges together with their high accuracy make the MT 60 and MT 101 HEIDENHAIN-METRO length gauges attractive for incoming inspection, production monitoring, quality control, or anywhere parts with very different dimensions are measured. But they are also easy to mount as highly accurate position encoders, for example on sliding devices or X-Y tables.

Plunger actuation

M version length gauges feature an integral motor that retracts and extends the plunger. While the MT 101 M operates at a constant gauging force, the MT 60 M allows you to select from three gauging force levels.

K version gauges have no integral plunger actuation. The plunger is freely movable. It can be connected to moving elements such as linear slides and X-Y tables by a coupling (see *Accessories*).

Mounting

The length gauges are mounted onto a flat surface by two screws. The M versions can also be mounted in the accessory MS 100 and MS 200 gauge stands.

Output signals

The MT 60 and MT 101 provide $\sim 11 \mu\text{A}_{\text{PP}}$ current signals for HEIDENHAIN subsequent electronics.

MT 60

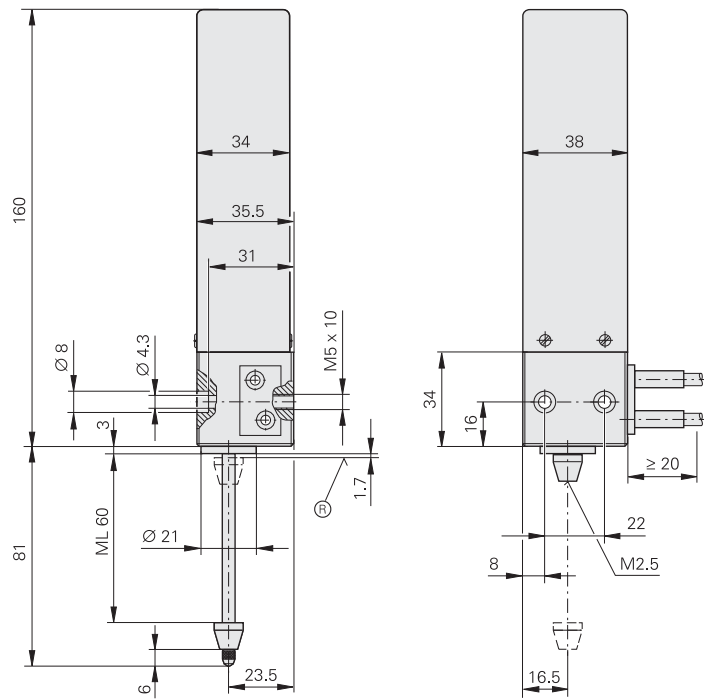

MT 101

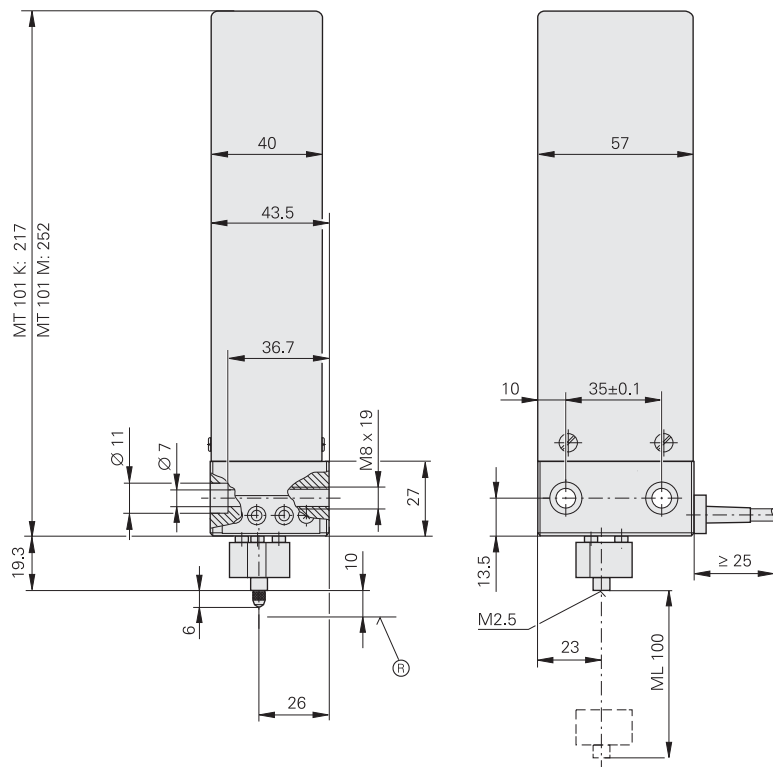

Dimensions in mm



Tolerancing ISO 8015

ISO 2768 - m H

< 6 mm: ± 0.2 mm

Ⓜ = Reference mark position

Specifications	MT 60M MT 60K	MT 101M MT 101K
Plunger actuation <i>MT xxM</i> <i>MT xxK</i>	By motor Plunger connected via separate coupling with moving machine part	
Measuring standard	DIADUR grating on silica glass; grating period 10 µm	
System accuracy	± 0.5 µm	± 1 µm
Recommd. meas. step	1 µm to 0.1 µm	
Reference mark	Approx. 1.7 mm from top	Approx. 10 mm from top
Measuring range	60 mm	100 mm
Gauging force Vertically downward Vertically upward Horizontal	With MT 60M 1 N/1.25 N/1.75 N – /– /0.75 N – /0.75 N/1.25 N	With MT 101 M 0.7 N with SG 101V – 0.7 N with SG 101 H
Required moving force with MT xxK	0.1 to 0.6 N (depending on operating attitude)	0.5 to 2 N (depending on operating attitude)
Radial force¹⁾	≤ 0.5 N	≤ 2 N
Operating attitude <i>MT xxM</i> <i>MT xxK</i>	Any Any	Vertically downward with SG 101V Horizontal with SG 101 H Any
Vibration 55 to 2000 Hz Shock 11 ms	≤ 100 m/s ² (EN 60068-2-6) ≤ 1000 m/s ² (EN 60068-2-27)	
Protection EN 60529	IP 50	
Operating temperature	10 to 40 °C; ref. temperature 20 °C	
Fastening	Plane surface	
Weight <i>MT xxM</i> without cable <i>MT xxK</i>	700 g 600 g	1400 g 1200 g
Incremental signals	~ 11 µApp; signal period 10 µm	
Measuring velocity²⁾	≤ 18 m/min	≤ 60 m/min
Electrical connection* Cable length	<ul style="list-style-type: none"> • Cable, 1.5 m, with 15-pin D-sub connector; • Cable 1.5 m with 9-pin M23 connector (male); ≤ 30 m with HEIDENHAIN cable	
Power supply <i>MT xxM</i> <i>MT xxK</i> <i>Switch box</i>	5 V ± 5 %/< 120 mA 5 V ± 5 %/< 70 mA –	5 V ± 5 %/< 70 mA 5 V ± 5 %/< 70 mA Via power adapter

Required accessories*	For MT 60M	For MT 101M
Switch box	SG 60 M	Vertical position: SG 101V Horizontal position: SG 101 H
Power adapter 100 V to 240 V	–	ID 648029-01

* Please indicate when ordering
¹⁾ Mechanically permissible

²⁾ Depending on the subsequent electronics

MT 60M



MT 101M



HEIDENHAIN-SPECTO

Length Gauges with $\pm 1 \mu\text{m}$ Accuracy

- Very compact dimensions
- Splash-proof

Thanks to their very small dimensions, the HEIDENHAIN-SPECTO length gauges are the product of choice for multipoint inspection apparatus and testing equipment.

Plunger actuation

The length gauges of the **ST 12x8** and **ST 30x8** series feature a spring-tensioned plunger that is extended at rest.

In the pneumatic length gauges **ST 12x7** and **ST 30x7** the plunger is retracted to its rest position by the integral spring. It is extended to the measuring position by the application of compressed air.

Mounting

The HEIDENHAIN-SPECTO length gauges are fastened by their 8h6 standard clamping shank.

Output signals

The HEIDENHAIN-SPECTO length gauges are available with various output signals. The **ST 128x** and **ST 308x** length gauges provide sinusoidal voltage signals with **1 V_{PP}** levels, which permit high interpolation. The **ST 127x** and **ST 307x** feature integrated digitizing and interpolation electronics with 5-fold or 10-fold interpolation (as ordered) and square-wave signals in **TTL** levels.

ST 12x7
ST 30x7

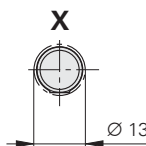
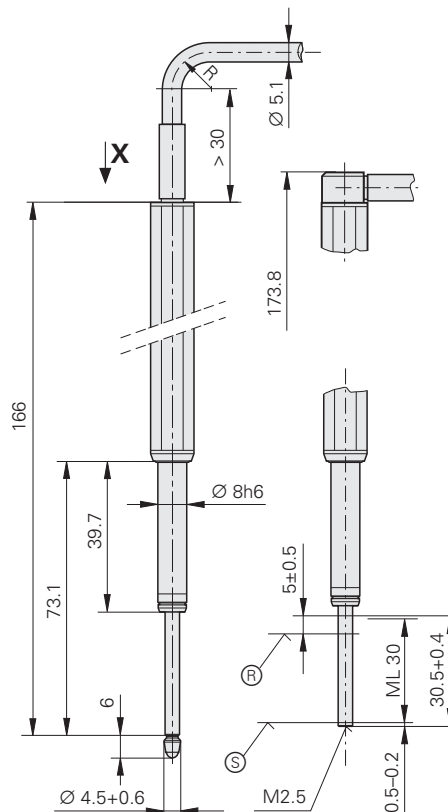
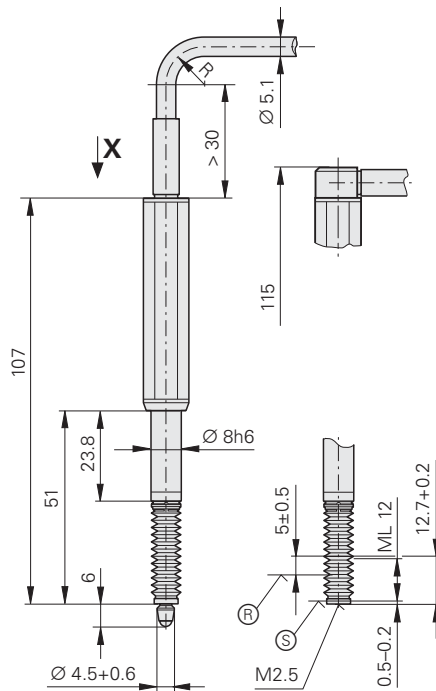
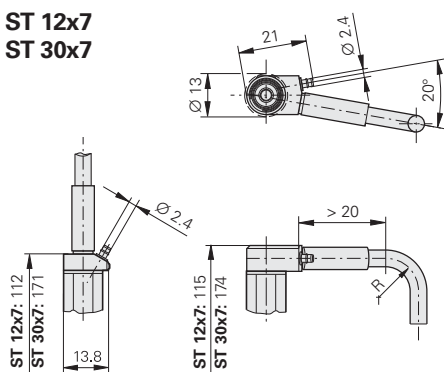

Dimensions in mm



Tolerancing ISO 8015

ISO 2768 - m H

< 6 mm: ± 0.2 mm

Ⓡ = Reference mark position

Ⓢ = Beginning of measuring length

Mechanical Data

Plunger actuation

Position of plunger at rest

Measuring standard

System accuracy

Reference mark

Measuring range

Gauging force with retracting plunger¹⁾

Vertically downward

Vertically upward

Horizontal

Radial force

Operating attitude

Vibration 55 to 2000 Hz

Shock 11 ms

Protection EN 60529

Operating temperature

Fastening

Weight without cable

Electrical Data

For length gauges

Incremental signals*

Signal period

Recommended measuring step

Mech. permissible traversing speed

Edge separation a at scanning frequency*/traverse speed

100 kHz $\leq 72 \text{ m/min}^3$

50 kHz $\leq 60 \text{ m/min}$

25 kHz $\leq 30 \text{ m/min}$

Electrical connection*









Cable outlet*





Cable length

Power supply

* Please indicate when ordering

¹⁾ See also *Gauging Force—Plunger Actuation*

ST 1278  ST 1288  1 V _{PP}		ST 3078  ST 3088  1 V _{PP}		ST 1277  ST 1287  1 V _{PP}		ST 3077  ST 3087  1 V _{PP}	
By measured object Extended				Pneumatic Retracted			
DIADUR grating on glass; grating period 20 μm							
± 1 μm							
Approx. 5 mm below upper stop							
12 mm		30 mm		12 mm		30 mm	
0.6 to 2.4 N 0.4 to 2.2 N 0.5 to 2.3 N		0.6 to 1.4 N 0.4 to 1.2 N 0.5 to 1.3 N		0.4 to 3.0 N (depending on pressure and operating attitude)		0.4 to 3.0 N (depending on pressure and operating attitude)	
≤ 0.8 N (mechanically permissible)							
Any							
≤ 100 m/s ² (EN 60068-2-6) ≤ 1000 m/s ² (EN 60068-2-27)							
IP 64 (for connecting elements see <i>Connecting Elements and Cables</i>)							
10 to 40 °C; ref. temperature 20 °C							
Clamping shank Ø 8h8							
40 g		50 g		40 g		50 g	

 ST 127x ST 307x		 1 V _{PP} ST 128x ST 308x	
 x 5 4 μm	 x 10 2 μm	 1 V _{PP} 20 μm	
1 μm ²⁾	0.5 μm ²⁾	1 μm/0.5 μm	
≤ 72 m/min			
≥ 0.48 μs ≥ 0.98 μs ≥ 1.98 μs	≥ 0.23 μs ≥ 0.48 μs ≥ 0.98 μs	-	
Cable, 1.5 m, with 15-pin D-sub connector (interface electronics integrated)		Cable 1.5 m with • D-sub connector, 15-pin • M23 connector, 12 pin	
Axial or radial			
≤ 30 m with HEIDENHAIN cable			
5 V ± 10 % / < 230 mA (without load)		5 V ± 10 % / < 90 mA	

²⁾ After 4-fold evaluation
³⁾ Mechanically limited

ST 1200



ST 3000



Accessories

Measuring Contacts

Ball-type contact

Steel ID 202504-01
 Carbide ID 202504-02
 Ruby ID 202504-03

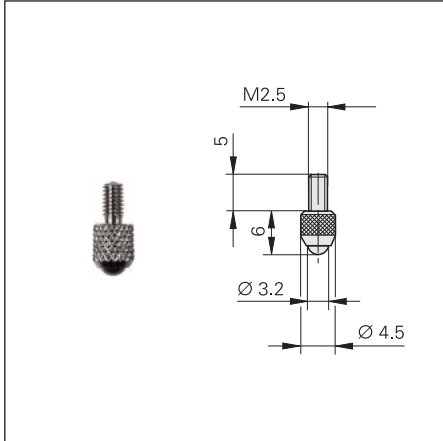

Domed contact

Carbide ID 229232-01

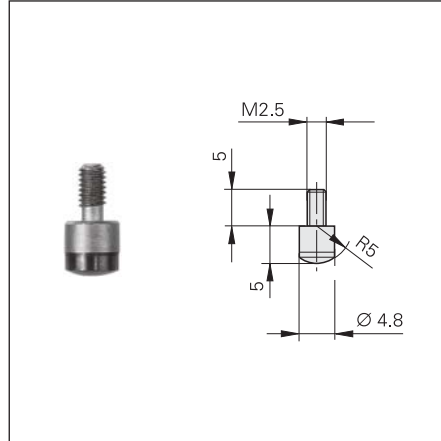

Flat contact

Steel ID 270922-01
 Carbide ID 202506-01

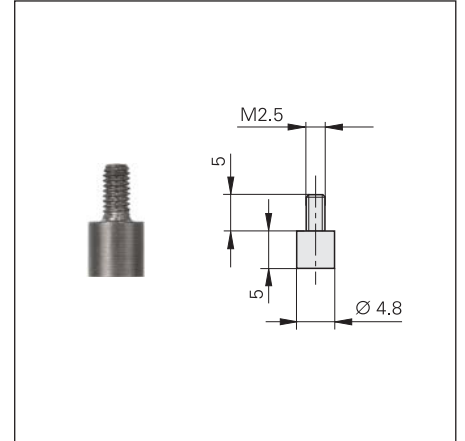

Pin-type contact

Steel ID 202505-01

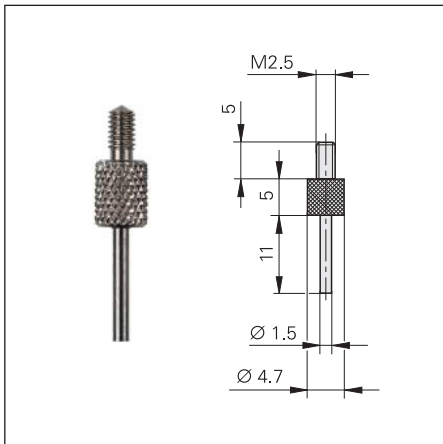

Knife-edge contact

Steel ID 202503-01

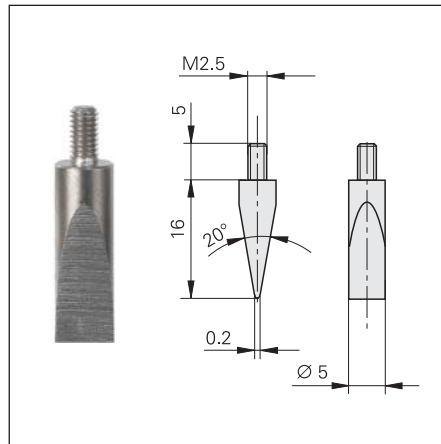

Dimensions in mm

 Tolerancing ISO 8015
 ISO 2768 - m H
 < 6 mm: ±0.2 mm

Roller contact, steel

For a low-friction contact with moving surfaces

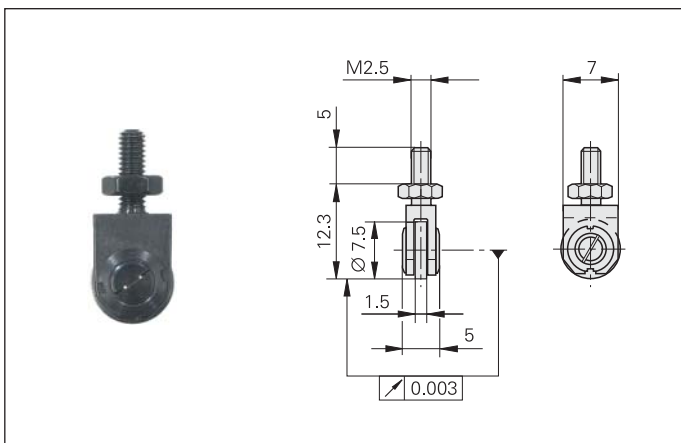
Crowned ID 202502-03
 Cylindrical ID 202502-04



Adjustable contact, carbide

For exact parallel alignment to the measuring plate surface

Flat ID 202507-01
 Knife-edged ID 202508-01

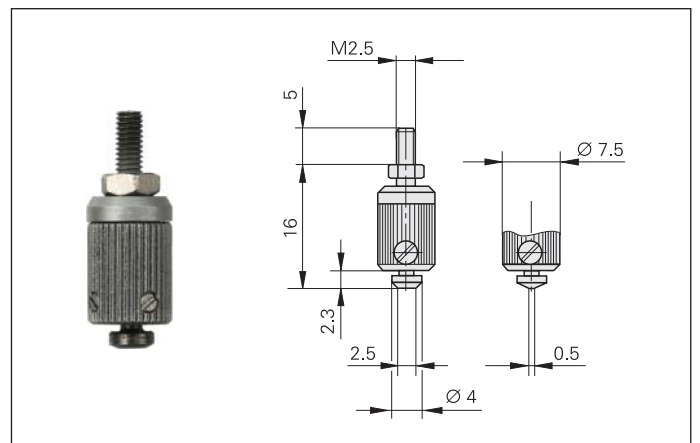

Switch Boxes, Coupling

Switch boxes for CT 2501, CT 6001, MT 60M, MT 101 M

Switch boxes are required for length gauges with motorized plunger actuation. The plunger is controlled through two push buttons or by external signal. The gauging force is adjustable at the SG 25M and SG 60M switch boxes in three stages.

SG 25M

ID 317436-01

SG 60M

ID 317436-02

SG 101V¹⁾

For the MT 101 M in vertical operation
ID 361 140-01

SG 101H¹⁾

For the MT 101 M in horizontal operation
ID 361 140-02

Connector (female) 3-pin

For external operation of the switch box
ID 340646-05

¹⁾ Separate power supply required

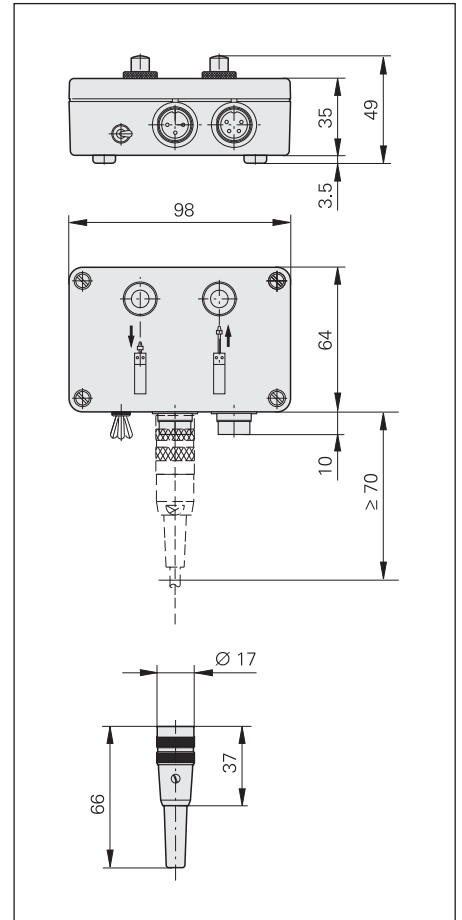

Power adapter for SG 101V/H

A power adapter connected to the switch box powers the MT 101 M

Voltage range 100 to 240 V
Exchangeable plug adapter
(U.S. and Euro connectors included in delivery)

ID 648029-01

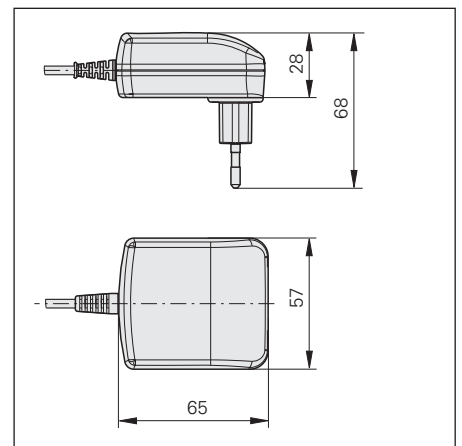

Coupling

For connecting the plunger of the length gauge (MT 60K and MT 101 K) to a moving machine element

ID 206310-01

Dimensions in mm

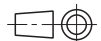

Tolerancing ISO 8015
ISO 2768 - m H
< 6 mm: ±0.2 mm

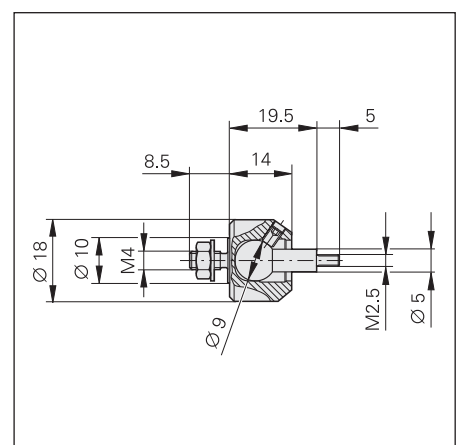

Accessories for HEIDENHAIN-CERTO Gauge Stand

CS 200 gauge stand

For length gauges CT 2501*
CT 6001

ID 221310-01

Overall height 349 mm
Base \varnothing 250 mm
Column \varnothing 58 mm
Weight 15 kg

*) With special holder

The flatness of the CS 200 is determined with the aid of a Fizeau interferometer.

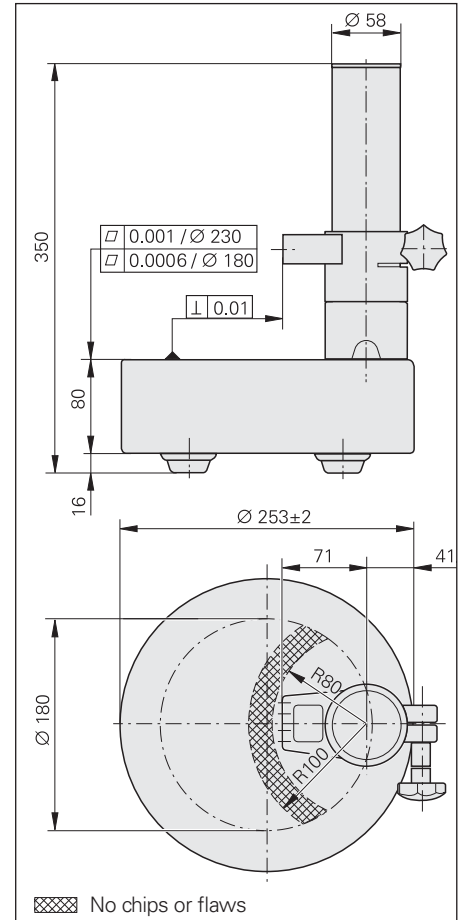

Holder for CS 200

For the CT 2501 with
 \varnothing 16 mm clamping shank

ID 324391-01

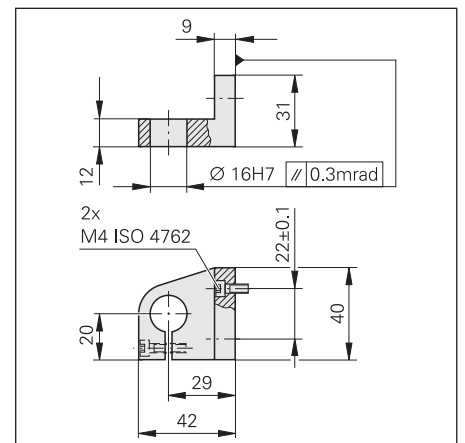

Dimensions in mm



Tolerancing ISO 8015
ISO 2768 - m H
< 6 mm: \pm 0.2 mm

Ceramic Suction Plate, Diaphragm Pump

Ceramic suction plate

Wear-resistant working surface with high surface quality specifically for inspecting gauge blocks

ID 223 100-01

The gauge block (class 1 or 2)—or any other object with a plane surface—is drawn by suction onto the top of the ceramic plate. The ceramic plate is likewise drawn to the granite base and held in place through negative gauge pressure.

Parts for connecting the ceramic suction plate with the diaphragm pump are among the items supplied:

- Pressure tubing 3 m
- T joint
- Connecting piece

Diaphragm pump

Source of suction for drawing the measured object and ceramic suction plate

ID 227 967-01

- Line voltage 230 V/50 Hz
- Power consumption 20 W
- Weight 2.3 kg

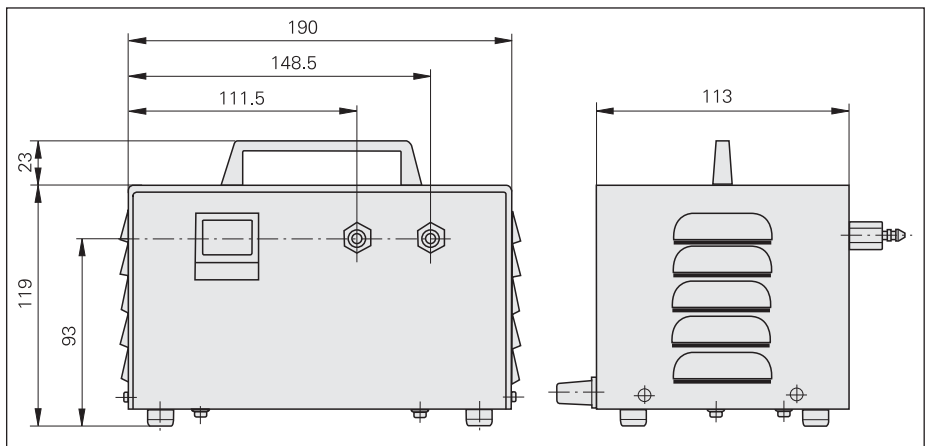
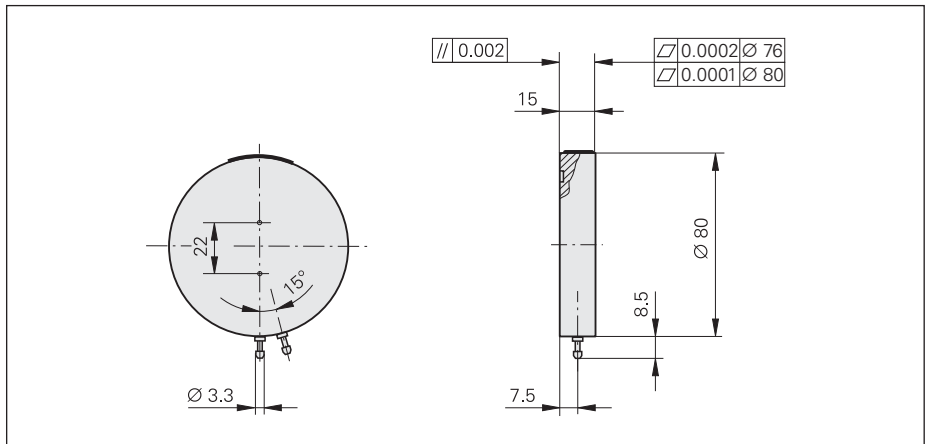

Dimensions in mm



Tolerancing ISO 8015
ISO 2768 - m H
< 6 mm: ±0.2 mm

Accessories for HEIDENHAIN-METRO and HEIDENHAIN-SPECTO Cable-Type Lifter, Gauge Stands

Cable lifter

For manual plunger actuation of MT 1200 and MT 2500. The integral pneumatic damping reduces the plunger extension speed to prevent rebounding, for example on very hard materials.

ID 257 790-01

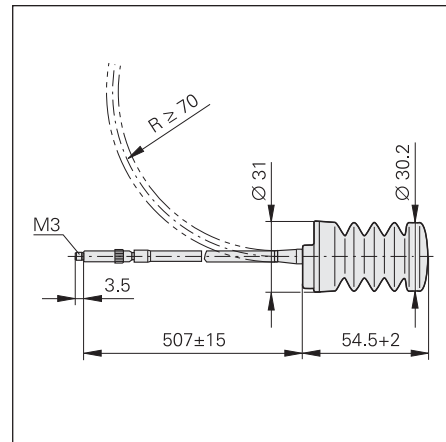

MS 200 gauge stand

For the models ST*
MT 1200*
MT 2500*

MT 60 M
MT 101 M

ID 244 154-01

Overall height 346 mm
Base Ø 250 mm
Column Ø 58 mm
Weight 18 kg

*) With special holder

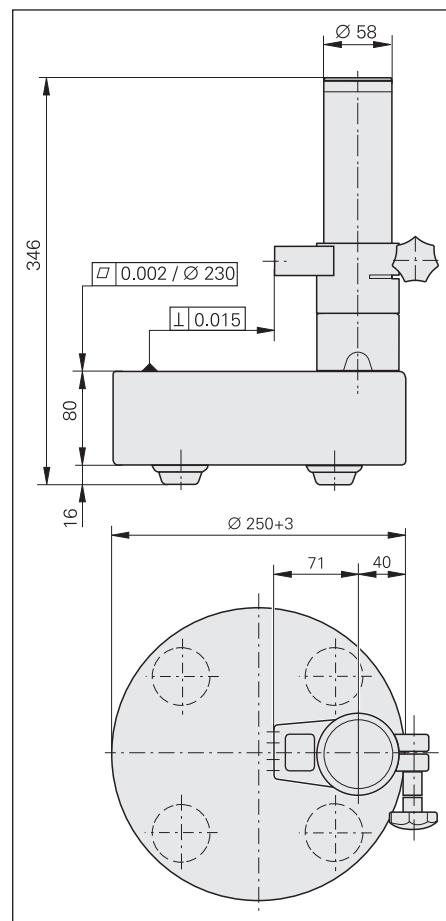

Holder for MS 200

For mounting the length gauge with an Ø 8 mm clamping shank, for example ST, MT 1200, MT 2500

ID 324 391-02

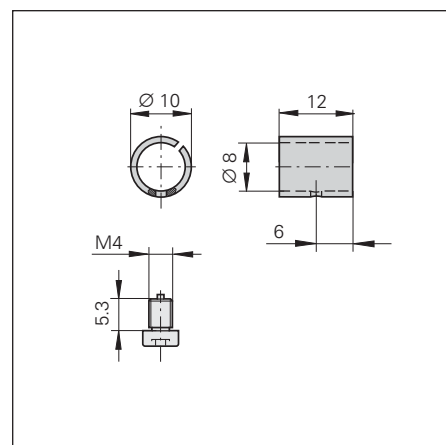

Clamping sleeve

For the models ST
MT 1200
MT 2500

For fixing the length gauge reliably without overloading the 8h6 clamping shank.

Consisting of:

Sleeve, clamping screw

ID 386 811-01 (1 units per package)

ID 386 811-02 (10 units per package)

Dimensions in mm



Tolerancing ISO 8015

ISO 2768 - m H

< 6 mm: ±0.2 mm

MS 45 gauge stand

For the models ST
MT 1200
MT 2500

ID 202 162-02

Overall height 196.5 mm
Base \varnothing 49 mm
Column \varnothing 22 mm
Weight 2.2 kg

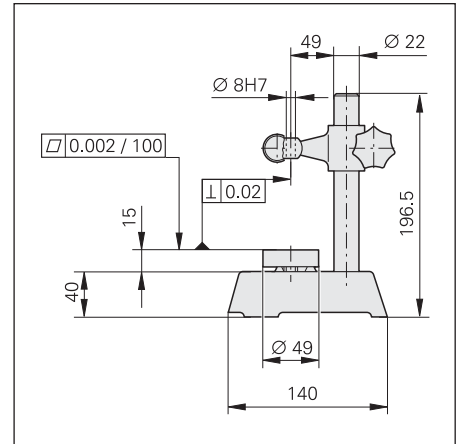

MS 100 gauge stand

For the models ST
MT 1200
MT 2500
MT 60M*
MT 101M*

ID 202 164-02

Overall height 385 mm
Measuring plate 100 mm x 115 mm
Column \varnothing 50 mm
Weight 18 kg

*) With special holder

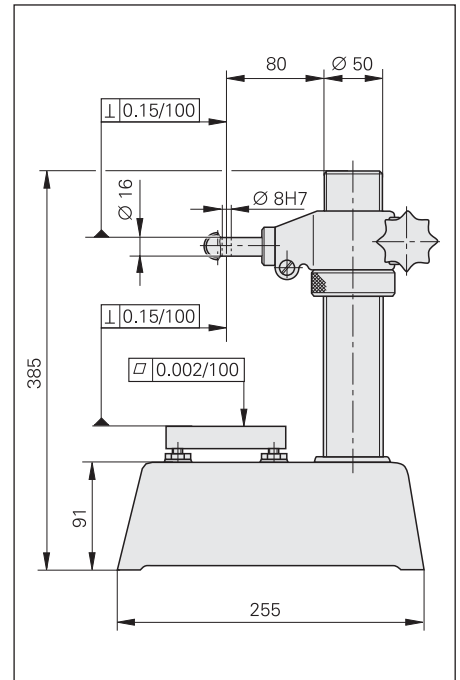

Holder for MS 100

For mounting the MT 60M
ID 207479-01

For mounting the MT 101M
ID 206260-01

Dimensions in mm

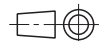

Tolerancing ISO 8015
ISO 2768 - m H
< 6 mm: \pm 0.2 mm

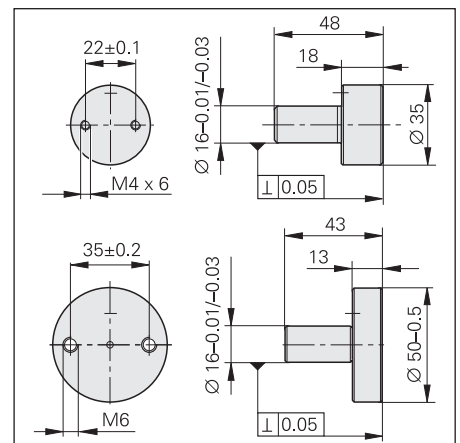

Position Display Units

ND 200 Series

The ND 200 series offers digital readouts for one axis. Due to their performance range they are predestined for measuring and inspection stations, but are also intended for simple positioning tasks. The universal encoder input permits connection of all incremental encoders with 11 μA_{PP} and 1 V_{PP} and absolute encoders with the EnDat 2.2 interface from HEIDENHAIN.

Execution

The ND 200 series features a sturdy aluminum die-cast housing. A large graphic TFT monitor displays the measured values, the status and the soft-key row. The splash-proof full-travel keyboard is built for the workshop. Two ND 28x displays can be mounted next to each other on an adapter (accessory) in a 19" housing.

Functions

The standard position display **ND 280** provides the basic functions for simple measuring tasks. The **ND 287** features numerous functions for measuring and processing individual positions, for example sorting and tolerance check mode, minimum/maximum value storage, measurement series storage. These data make it possible to calculate mean values and standard deviations and display them in histograms or control charts. With its modular design, the ND 287 permits connection of a second encoder for sum/difference measurement or of an analog sensor, for example for temperature compensation.

Data interfaces

The ND 28x have serial interfaces for measured value transfer to a PC or printer, for input/output of parameters and compensation value lists, and for diagnostics:

- USB
- RS-232-C/V.24
- Ethernet 100BaseT (option, only with ND 287)

The measured value transfer can be started at the ND keyboard, through an external command, through the RS-232-C/V.24 software command CTRL B, or by an adjustable internal clock.

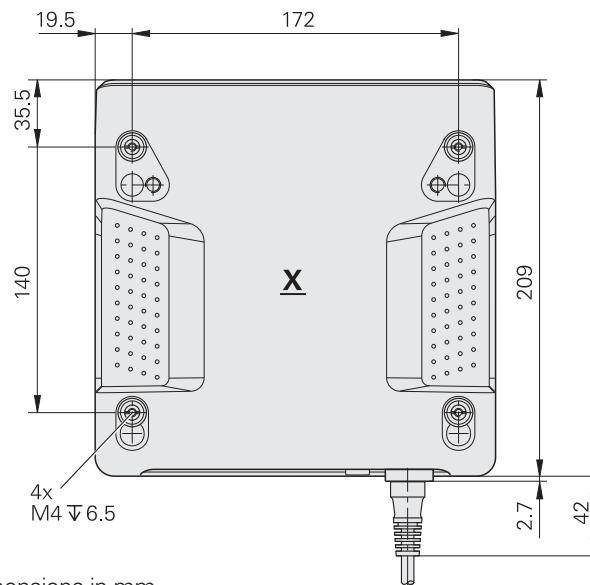
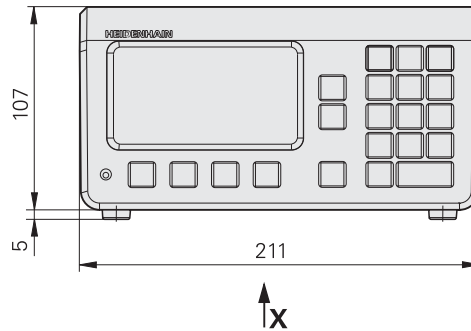

Dimensions in mm



Tolerancing ISO 8015
ISO 2768 - m H
< 6 mm: ± 0.2 mm

Accessories:

Mounting base

For 19" housing
ID 654 020-01

Encoder module

Input assembly for second encoder with 1 V_{PP} , 11 μA_{PP} or EnDat 2.2 interface
ID 654 017-01

Analog module

Input assembly for ± 10 V analog sensor
ID 654 018-01

Ethernet module

ID 654 019-01

Encoder inputs
Input frequency
Subdivision factor
Display step ²⁾
Analog input
Resolution
Display
Status display
Functions
Axis-error compensation
Data interface
Switching outputs For tasks in automation
Switching inputs For tasks in automation
Power connection
Operating temperature
Protection EN 60529
Weight

ND 280	ND 287
1 x $\sim 1 V_{PP}$, $\sim 11 \mu A_{PP}$ or EnDat 2.2 ¹⁾	1 x $\sim 1 V_{PP}$, $\sim 11 \mu A_{PP}$ or EnDat 2.2 ¹⁾ Option: Second input through encoder module
$\sim 1 V_{PP}: \leq 500 \text{ kHz}; 11 \mu A_{PP}: \leq 100 \text{ kHz}$	
4096-fold	
Adjustable, max. 9 digits Linear axis: 0.5 to 0.002 μm Angular axis: 0.5° to 0.00001° or 00°00'00.1"	
–	Option: $\pm 10 \text{ V}$ through analog module
–	5 mV
Monochrome TFT screen	Color TFT screen
Position values, dialogs and input, graphic functions and soft keys	
Operating mode, REF, datum, scaling factor, compensation, stopwatch, unit of measure, soft-key level	
<ul style="list-style-type: none"> • REF reference-mark evaluation for distance-coded or single reference marks • 2 datums • Distance-to-go mode • Integrated help and diagnostics • Remote operation via serial interface 	
–	<ul style="list-style-type: none"> • Sorting • Measurement series with min./max. value storage • Saving measured values (max. 10 000) • Calculation of mean and standard deviation • Graphic depiction of distribution/histogram • Sum/difference display (with 2nd encoder module) • Thermal compensation (with analog module)
<i>Linear axis:</i> Linear and multipoint over up to 200 points <i>Angle axis:</i> Multipoint linear with 180 compensation points (every 2°)	
<ul style="list-style-type: none"> • RS-232-C/V.24 • USB 	
–	Option: Ethernet 100BaseT, via Ethernet module
–	<ul style="list-style-type: none"> • Zero crossover • Trigger points 1 and 2 • Sorting signals "<" and ">" • Errors
–	<ul style="list-style-type: none"> • Zero reset, preset • Cross over reference point and ignore ref. signals • Meas. value output or display freeze (pulse or contact) • Start measurement series • Minimum/maximum/difference value • Gating of the two encoder inputs • Sum or difference display • Display measured value 1 or measured value 2
100 V~ to 240 V~ (–10 % to +15 %), 50 Hz to 60 Hz ($\pm 2 \text{ Hz}$); 30 W	
0 °C to 45 °C	
IP 40, front IP 54	
Approx. 2.5 kg	



¹⁾ Automatic detection of interface

²⁾ Depends on the signal period of the connected encoder
(Display step \approx signal period/4096)

ND 287 Features

In addition to the standard functions, such as reference-mark evaluation, reset and datum setting, counting direction and display-step switching, the ND 287 position display unit features numerous application-oriented functions. Together with the length gauge, it forms a full-fledged measuring station and is also suited for statistical process control.

Sorting and tolerance checking

With the sorting function, workpieces can be inspected for dimensional accuracy and divided into classes. To do so, the ND 287 compares the displayed measured value with an upper and lower limit value previously entered with the keypad. The result (whether the measured value is below, above or within tolerance) is indicated in color in the status display as a value or with one of the symbols <, = or >. In addition, a corresponding signal is available at the switching outputs.

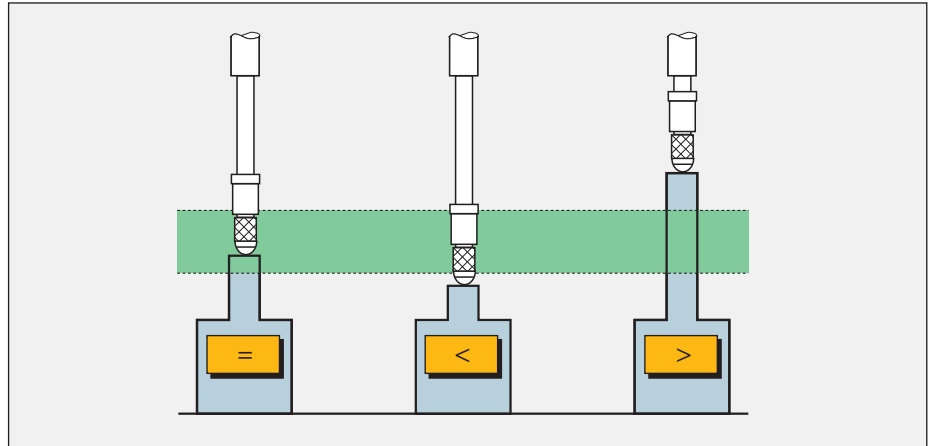

Workpiece sorting

Recording of measurement series

The ND 287 features a measured value memory for in total 10000 positions for recording measurement series. These values are available for internal evaluation or they can be read out in a block. The measured values are written per keystroke, over an external command, or cyclically by an internal clock (≥ 20 ms; adjustable) and written to a table. While the measurement series is running, the display can show the minimum value, maximum value, or the difference of the two instead of the current measured value.

Evaluation of measurement series

After ending a measurement series, the saved measured values can be displayed and statistically evaluated in various ways.

- Diagram with **error curve**
- Frequency distribution by **histogram** (symmetric or non-symmetric)
- Arithmetic **mean**
- **Standard deviation**
- Generation of **control charts** (mean value, \bar{x} standard deviation s , range R)
- **Maximum/minimum value storage**
- Calculation of the **difference** of minimum and maximum measured value

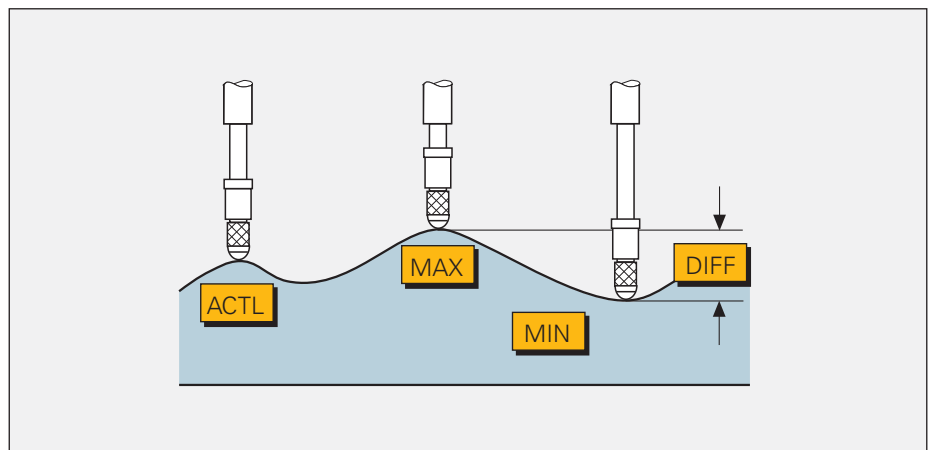
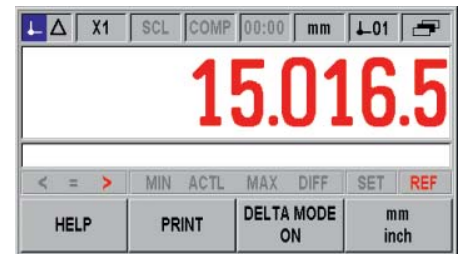

Minimum/maximum value storage

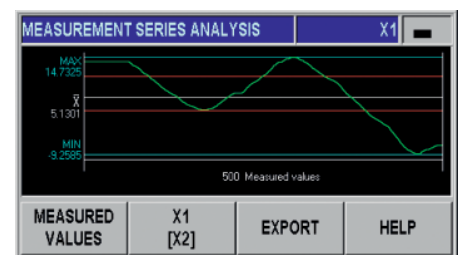
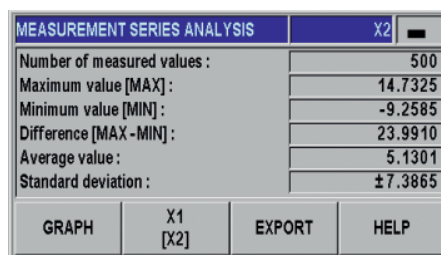

Combination with a second encoder

A second encoder can be connected to the ND 287 through the additional encoder input assembly module (option). The data from two encoders can be combined through mathematical operands. Like the two measured values, the result is saved in the measured value memory. This opens further areas of application:

Sum/difference display

The ND 287 calculates the sum or difference of the two measured values and—depending on the formula entered—displays the result. The measured values from the two encoders can also be displayed individually.

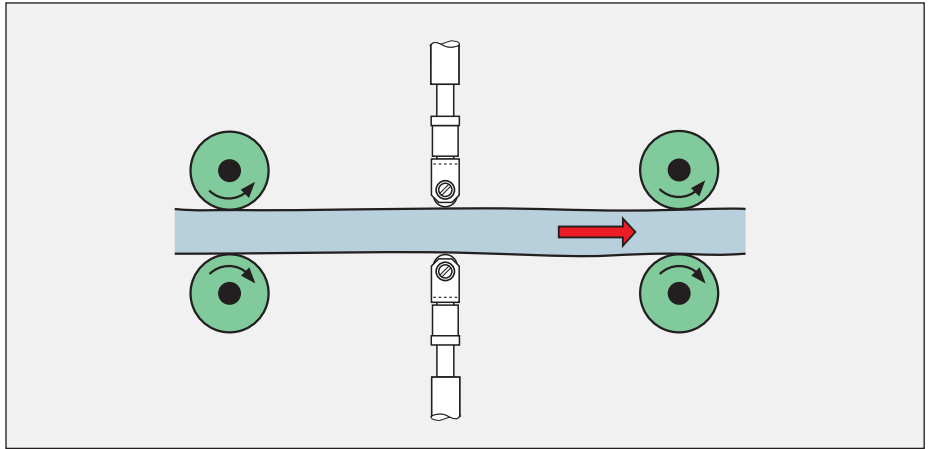

Sum of two length gauges

Position-dependent measurements

A measured value is recorded depending on another measured value. This makes it possible to connect each error value with exactly one position, for example during concentricity testing or inspection for guideway error (in preparation).

Input from an analog sensor

An analog module can be connected in place of the additional encoder module. Any sensor with an $\pm 10\text{ V}$ interface can provide input of other physical quantities such as pressure, temperature etc.

Graphic display

The color graphic screen of the ND 287 provides detailed displays of measurement series and statistical evaluations, including the entered sorting or action limits. Also, the output signals of the connected encoder can be qualitatively evaluated as a Lissajou figure.

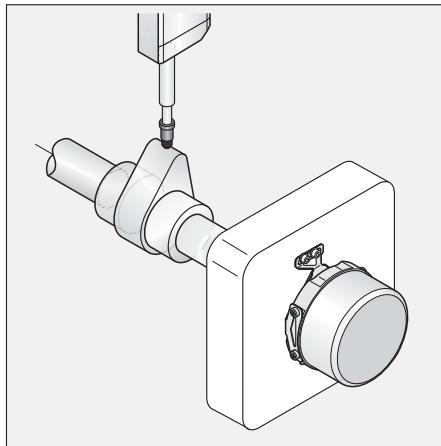

Measuring the cam height depending on the angle

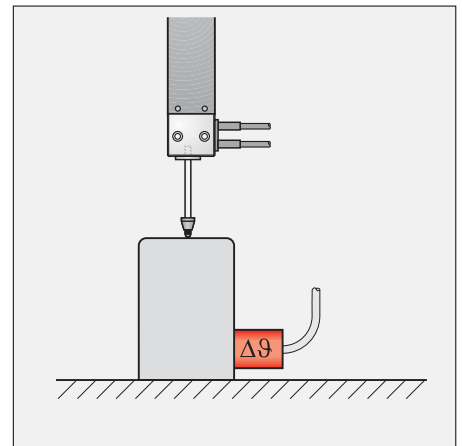

Temperature measurement for thermal compensation

Display freeze

To be able to read the display reliably in spite of quickly changing values you can send an external signal to hold the display as long as desired. The true position value is counted internally until a fresh display value is called. The Display Freeze feature operates in one of two modes:

- With the **frozen display** the display value is frozen by the first latching signal. Every further latch signal updates the display to the current measured value, and the display remains frozen at the new value.
- **Frozen/concurrent display**—the display freezes only as long as the latch signal is present. With the signal off, the display shows the current measured values again.

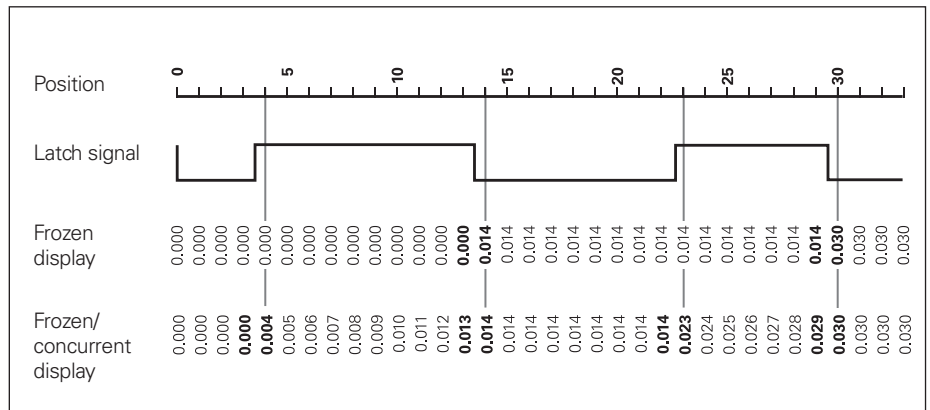

Counter Card

IK 220

Universal PC counter card

The IK 220 is a PC expansion board for recording the measured values of two incremental or absolute linear or angle encoders. The subdivision and counting electronics subdivide the sinusoidal input signals to generate up to 4096 measuring steps. A driver software package is included in delivery.



For more information, see the *IK 220 Product Information* as well as the *Interface Electronics Product Overview*.

	IK 220			
Input signals (switchable)	~ 1 V _{PP}	~ 11 μA _{PP}	EnDat 2.1	SSI
Encoder inputs	2 D-sub connections (15-pin) male			
Input frequency	≤ 500 kHz	≤ 33 kHz	–	
Cable length	≤ 60 m		≤ 50 m	≤ 50 m
Signal subdivision (signal period : meas. step)	Up to 4096-fold			
Data register for measured values (per channel)	48 bits (44 bits used)			
Internal memory	For 8192 position values			
Interface	PCI bus (plug and play)			
Driver software and demonstration program	For Windows 98/NT/2000/XP in VISUAL C++, VISUAL BASIC and BORLAND DELPHI			
Dimensions	Approx. 190 mm × 100 mm			

Interfaces

Incremental Signals $\sim 11 \mu\text{A}_{PP}$

HEIDENHAIN encoders with $\sim 11 \mu\text{A}_{PP}$ interface provide current signals. They are intended for connection to ND position display units or EXE pulse-shaping electronics from HEIDENHAIN.

The sinusoidal **incremental signals** I_1 and I_2 are phase-shifted by 90° elec. and have signal levels of approx. $11 \mu\text{A}_{PP}$. The illustrated sequence of output signals— I_2 lagging I_1 —applies for the retracting plunger.

The **reference mark signal** I_0 has a usable component G of approx. $5.5 \mu\text{A}$.

The data on **signal amplitude** apply when the power supply given in the *Specifications* is connected to the encoder. They refer to a differential measurement between the associated outputs. The signal amplitude decreases with increasing frequency. The **cutoff frequency** indicates the scanning frequency at which a certain percentage of the original signal amplitude is maintained:

- -3 dB cutoff frequency: 70% of the signal amplitude
- -6 dB-cutoff frequency: 50% of the signal amplitude

Interpolation/resolution/measuring step

The output signals of the $11 \mu\text{A}_{PP}$ interface are usually interpolated in the subsequent electronics in order to attain sufficiently high resolutions.

Measuring steps for **position measurement** are recommended in the *Specifications*. For special applications, other resolutions are also possible.

Interface	Sinusoidal current signals $\sim 11 \mu\text{A}_{PP}$
Incremental signals	Two nearly sinusoidal signals I_1 and I_2 Signal amplitude M : 7 to $16 \mu\text{A}_{PP}$ / typically $11 \mu\text{A}_{PP}$ Asymmetry $IP - NI/2M$: ≤ 0.065 Signal ratio M_A/M_B : 0.8 to 1.25 Phase angle $ \varphi_1 + \varphi_2 /2$: $90^\circ \pm 10^\circ$ elec.
Reference-mark signal	One or more signal peaks I_0 Usable component G : 2 to $8.5 \mu\text{A}$ Signal-to-noise ratio E, F : $\geq 0.4 \mu\text{A}$ Zero crossovers K, L : $180^\circ \pm 90^\circ$ elec.
Connecting cable	Shielded HEIDENHAIN cable PUR $[3(2 \cdot 0.14 \text{ mm}^2) + (2 \cdot 1 \text{ mm}^2)]$ Cable length Max. 30 m at 90 pF/m distributed capacitance Propagation time 6 ns/m

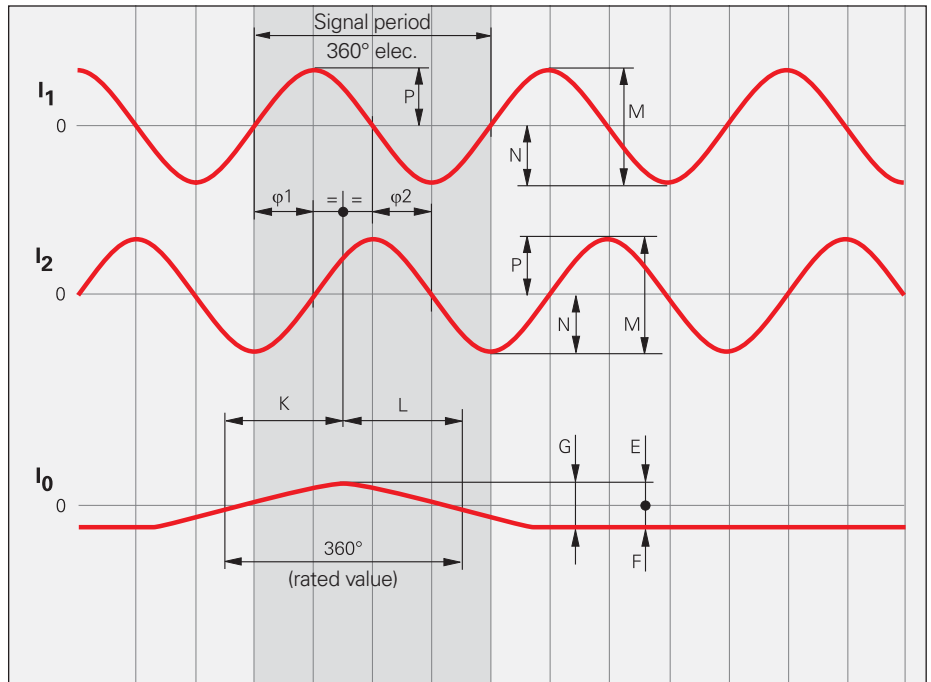

Pin layout

9-pin HEIDENHAIN connector				15-pin D-sub connector For ND 28x/IK 215 or on encoder						
	Power supply			Incremental signals						
	3	4	Housing	9	1	2	5	6	7	8
	4	2		6	1	9	3	11	14	7
	U_P	0V	Ext. shield	Internal shield	I_1+	I_1-	I_2+	I_2-	I_0+	I_0-
	Brown	White	-	White/Brown	Green	Yellow	Blue	Red	Gray	Pink

U_P = power supply voltage

Vacant pins or wires must not be used!

Shield on housing

Color assignment applies only to extension cable.

Interfaces

Incremental Signals $\sim 1 V_{PP}$

HEIDENHAIN encoders with $\sim 1V_{PP}$ interface provide voltage signals that can be highly interpolated.

The sinusoidal **incremental signals** A and B are phase-shifted by 90° elec. and have an amplitude of typically $1 V_{PP}$. The illustrated sequence of output signals—with B lagging A—applies for the direction of motion shown in the dimension drawing.

The **reference mark signal** R has a usable component G of approx. $0.5 V$. Next to the reference mark, the output signal can be reduced by up to $1.7 V$ to a quiescent value H. This must not cause the subsequent electronics to overdrive. Even at the lowered signal level, signal peaks with the amplitude G can also appear.

The data on **signal amplitude** apply when the power supply given in the specifications is connected to the encoder. They refer to a differential measurement at the 120-ohm terminating resistor between the associated outputs. The signal amplitude decreases with increasing frequency. The **cutoff frequency** indicates the scanning frequency at which a certain percentage of the original signal amplitude is maintained:

- $-3\text{ dB} \triangleq 70\%$ of the signal amplitude
- $-6\text{ dB} \triangleq 50\%$ of the signal amplitude

The data in the signal description apply to motions at up to 20% of the -3 dB cutoff frequency.

Interpolation/resolution/measuring step

The output signals of the $1 V_{PP}$ interface are usually interpolated in the subsequent electronics in order to attain sufficiently high resolutions. For **velocity control**, interpolation factors are commonly over $1\,000$ in order to receive usable velocity information even at low speeds.

Measuring steps for **position measurement** are recommended in the specifications. For special applications, other resolutions are also possible.

Short-circuit stability

A temporary short circuit of one signal output to $0 V$ or U_P (except encoders with $U_{Pmin} = 3.6 V$) does not cause encoder failure, but it is not a permissible operating condition.

Short circuit at	20 °C	125 °C
One output	< 3 min	< 1 min
All outputs	< 20 s	< 5 s

Interface	Sinusoidal voltage signals $\sim 1 V_{PP}$
Incremental signals	2 nearly sinusoidal signals A and B Signal amplitude M: 0.6 to $1.2 V_{PP}$; typically $1 V_{PP}$ Asymmetry $ P - N /2M$: ≤ 0.065 Signal ratio M_A/M_B : 0.8 to 1.25 Phase angle $ \varphi_1 + \varphi_2 /2$: $90^\circ \pm 10^\circ$ elec.
Reference-mark signal	One or more signal peaks R Usable component G: $\geq 0.2 V$ Quiescent value H: $\leq 1.7 V$ Switching threshold E, F: 0.04 to $0.68 V$ Zero crossovers K, L: $80^\circ \pm 90^\circ$ elec.
Connecting cable	Shielded HEIDENHAIN cable PUR $[4(2 \times 0.14\text{ mm}^2) + (4 \times 0.5\text{ mm}^2)]$ Cable length Propagation time Max. 150 m at 90 pF/m distributed capacitance 6 ns/m

These values can be used for dimensioning of the subsequent electronics. Any limited tolerances in the encoders are listed in the specifications. For encoders without integral bearing, reduced tolerances are recommended for initial servicing (see the mounting instructions).

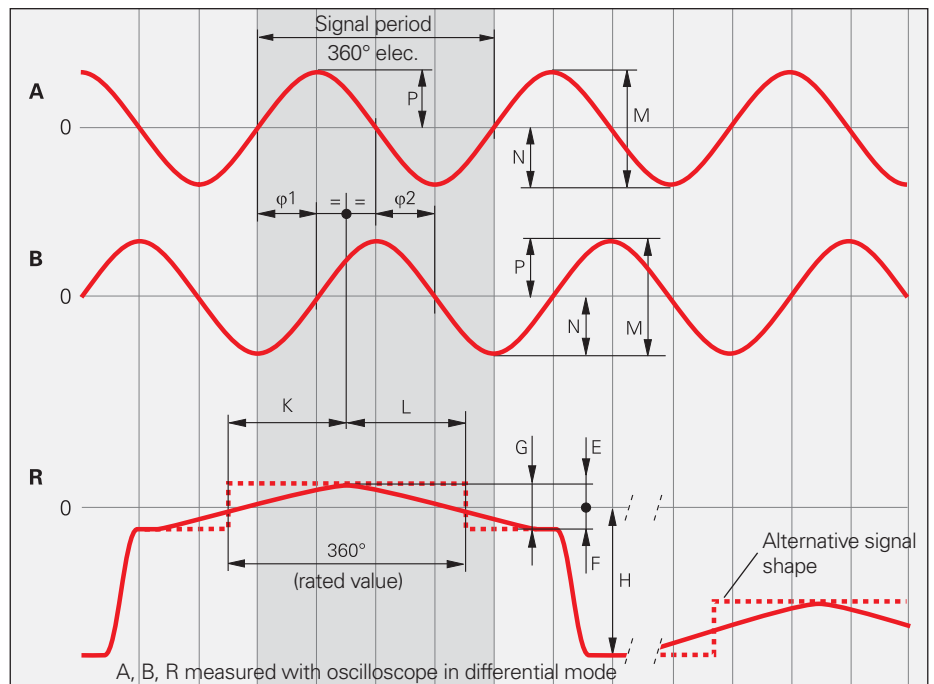

Cutoff frequency

Typical signal amplitude curve with respect to the scanning frequency

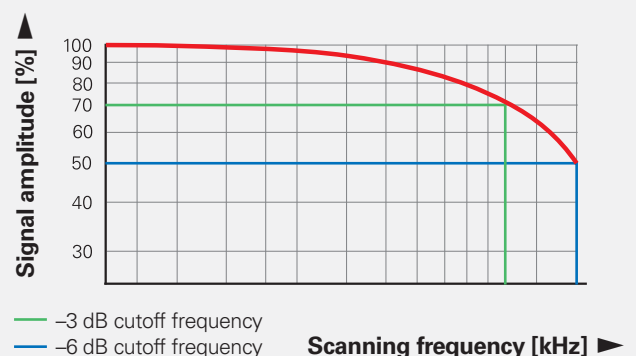

Input circuitry of the subsequent electronics

Dimensioning

Operational amplifier MC 34074
 $Z_0 = 120 \Omega$
 $R_1 = 10 \text{ k}\Omega$ and $C_1 = 100 \text{ pF}$
 $R_2 = 34.8 \text{ k}\Omega$ and $C_2 = 10 \text{ pF}$
 $U_B = \pm 15 \text{ V}$
 U_1 approx. U_0

-3dB cutoff frequency of circuitry

Approx. 450 kHz
 Approx. 50 kHz with $C_1 = 1000 \text{ pF}$
 and $C_2 = 82 \text{ pF}$
 The circuit variant for 50 kHz does reduce the bandwidth of the circuit, but in doing so it improves its noise immunity.

Circuit output signals

$U_a = 3.48 V_{PP}$ typical
 Gain 3.48

Monitoring of the incremental signals

The following sensitivity levels are recommended for monitoring the signal amplitude M :

Lower threshold: $0.30 V_{PP}$
 Upper threshold: $1.35 V_{PP}$

Incremental signals Reference-mark signal

$R_a < 100 \Omega$, typically 24Ω
 $C_a < 50 \text{ pF}$
 $\Sigma I_a < 1 \text{ mA}$
 $U_0 = 2.5 \text{ V} \pm 0.5 \text{ V}$
 (relative to 0V of the power supply)

Encoder

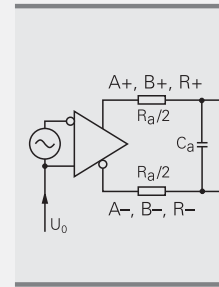

Subsequent electronics

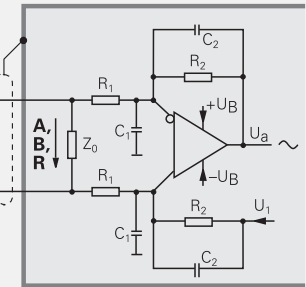

Pin layout

12-pin coupling M23		12-pin connector M23				15-pin D-sub connector For ND 28x/IK 215 or on encoder								
	Power supply				Incremental signals						Other signals			
	12	2	10	11	5	6	8	1	3	4	9	7	/	
	4	12	2	10	1	9	3	11	14	7	5/6/8/15	13	/	
	U_P	Sensor U_P	0V	Sensor 0V	A+	A-	B+	B-	R+	R-	Vacant	Vacant	Vacant	
	Brown/ Green	Blue	White/ Green	White	Brown	Green	Gray	Pink	Red	Black	/	Violet	Yellow	

Shield on housing; U_P = power supply voltage

Sensor: The sensor line is connected internally with the corresponding power line.

Vacant pins or wires must not be used!

Color assignment applies only to extension cable.

Interfaces

Incremental Signals TTL

HEIDENHAIN encoders with  TTL interface incorporate electronics that digitize sinusoidal scanning signals with or without interpolation.

The **incremental signals** are transmitted as the square-wave pulse trains U_{a1} and U_{a2} , phase-shifted by 90° elec. The **reference mark signal** consists of one or more reference pulses U_{a0} , which are gated with the incremental signals. In addition, the integrated electronics produce their **inverse signals** $\overline{U_{a1}}$, $\overline{U_{a2}}$ and $\overline{U_{a0}}$ for noise-proof transmission. The illustrated sequence of output signals—with U_{a2} lagging U_{a1} —applies for the direction of motion shown in the dimension drawing.

The **fault-detection signal** $\overline{U_{aS}}$ indicates fault conditions such as breakage of the power line or failure of the light source. It can be used for such purposes as machine shut-off during automated production.

The distance between two successive edges of the incremental signals U_{a1} and U_{a2} through 1-fold, 2-fold or 4-fold evaluation is one **measuring step**.

The subsequent electronics must be designed to detect each edge of the square-wave pulse. The minimum **edge separation a** listed in the *Specifications* applies for the illustrated input circuitry with a cable length of 1 m, and refers to a measurement at the output of the differential line receiver. Propagation-time differences in cables additionally reduce the edge separation by 0.2 ns per meter of cable length. To prevent counting error, design the subsequent electronics to process as little as 90% of the resulting edge separation.

The max. permissible **shaft speed** or **traversing velocity** must never be exceeded.

The permissible **cable length** for transmission of the TTL square-wave signals to the subsequent electronics depends on the edge separation a . It is max. 100 m, or 50 m for the fault detection signal. This requires, however, that the power supply (see *Specifications*) be ensured at the encoder. The sensor lines can be used to measure the voltage at the encoder and, if required, correct it with a closed-loop system (remote sense power supply).

Interface	Square-wave signals  TTL
Incremental signals	2 TTL square-wave signals U_{a1}, U_{a2} and their inverted signals $\overline{U_{a1}}$, $\overline{U_{a2}}$
Reference-mark signal Pulse width Delay time	1 or more TTL square-wave pulses U_{a0} and their inverted pulses $\overline{U_{a0}}$ 90° elec. (other widths available on request); LS 323: ungated $ t_d \leq 50$ ns
Fault-detection signal Pulse width	1 TTL square-wave pulse $\overline{U_{aS}}$ Improper function: LOW (upon request: U_{a1}/U_{a2} high impedance) Proper function: HIGH $t_S \geq 20$ ms
Signal level	Differential line driver as per EIA standard RS 422 $U_H \geq 2.5$ V at $-I_H = 20$ mA $U_L \leq 0.5$ V at $I_L = 20$ mA
Permissible load	$Z_0 \geq 100 \Omega$ between associated outputs $ I_L \leq 20$ mA max. load per output $C_{load} \leq 1000$ pF with respect to 0 V Outputs protected against short circuit to 0 V
Switching times (10% to 90%)	$t_r / t_f \leq 30$ ns (typically 10 ns) with 1 m cable and recommended input circuitry
Connecting cable Cable length Propagation time	Shielded HEIDENHAIN cable PUR [$4(2 \times 0.14 \text{ mm}^2) + (4 \times 0.5 \text{ mm}^2)$] Max. 100 m ($\overline{U_{aS}}$ max. 50 m) at 90 pF/m distributed capacitance 6 ns/m

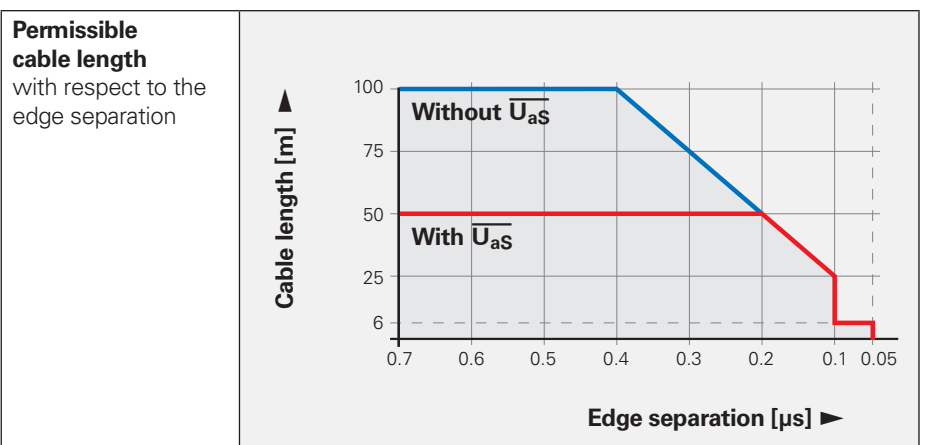
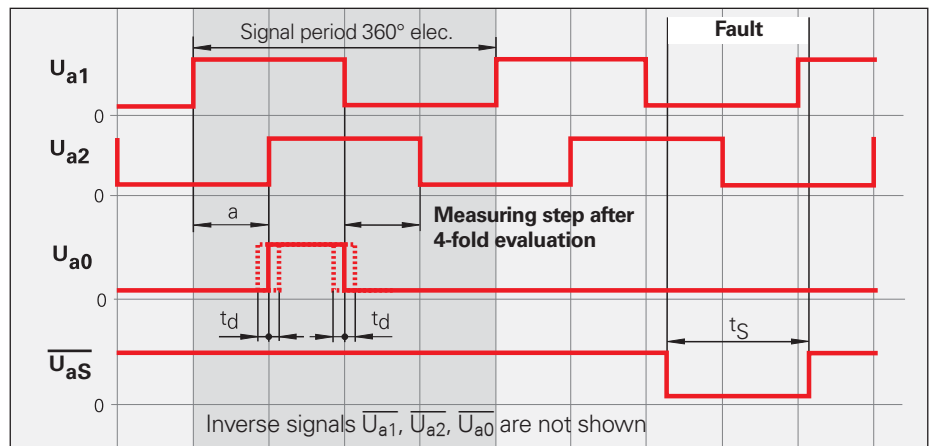

Input circuitry of the subsequent electronics

Dimensioning

IC₁ = Recommended differential line receivers
 DS 26 C 32 AT
 Only for a > 0.1 μs:
 AM 26 LS 32
 MC 3486
 SN 75 ALS 193

R₁ = 4.7 kΩ

R₂ = 1.8 kΩ

Z₀ = 120 Ω

C₁ = 220 pF (serves to improve noise immunity)

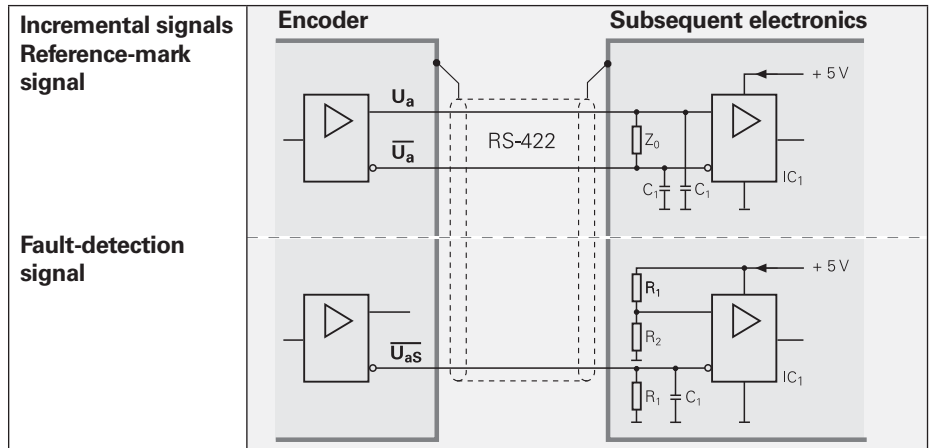

Pin layout

15-pin D-sub connector					12-pin HEIDENHAIN connector								
Power supply					Incremental signals						Other signals		
12	2	10	11	5	6	8	1	3	4	7	/	9	
4	12	2	10	1	9	3	11	14	7	13	5/6/8	15	
U _P	Sensor U _P	0V	Sensor 0V	U _{a1}	U _{a1}	U _{a2}	U _{a2}	U _{a0}	U _{a0}	U _{aS} ¹⁾	Vacant	Vacant ²⁾	
Brown/Green	Blue	White/Green	White	Brown	Green	Gray	Pink	Red	Black	Violet	–	Yellow	

Shield on housing; **U_P** = power supply voltage

Sensor: The sensor line is connected internally with the corresponding power line.

¹⁾ **LS 323:** Vacant

²⁾ **Exposed linear encoders:** Switchover TTL/11 μAPP for PWT

Vacant pins or wires must not be used!

Color assignment applies only to extension cable.

Connecting Elements and Cables

General Information

Connector (insulated): Connecting element with coupling ring; available with male or female contacts.

Symbols  

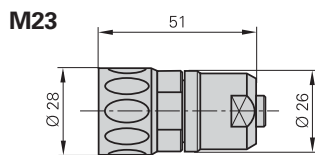

Coupling (insulated): Connecting element with external thread; available with male or female contacts.

Symbols  

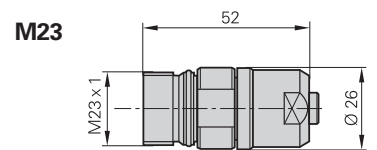

Mounted coupling with central fastening

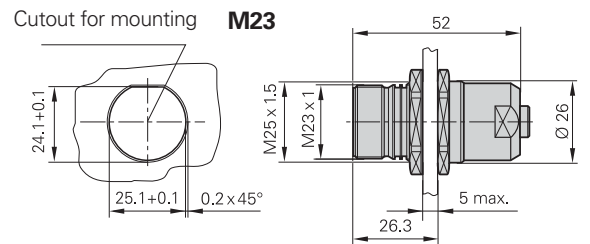

Mounted coupling with flange

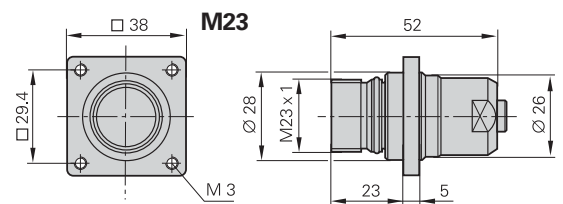

Flange socket: Permanently mounted on the encoder or a housing, with external thread (like the coupling), and available with male or female contacts.

Symbols  

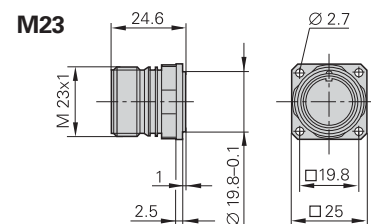

D-sub connector: For HEIDENHAIN controls, counters and IK absolute value cards.

Symbols  

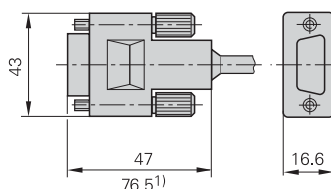

¹⁾ With integrated interpolation electronics

The pins on connectors are **numbered** in the direction opposite to those on couplings or flange sockets, regardless of whether the contacts are

male contacts or  
female contacts.  





When engaged, the connections provide **protection** to IP 67 (D-sub connector: IP 50; EN 60529). When not engaged, there is no protection.

Accessories for flange sockets and M23 mounted couplings

Bell seal
ID 266526-01

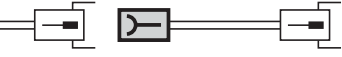
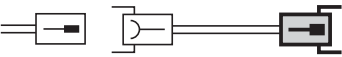
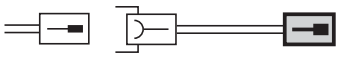

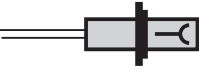
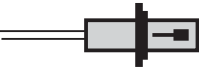
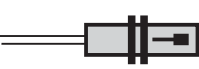

Threaded metal dust cap
ID 219926-01

Connecting Elements



			15-pin	
Connector on connecting cable to connector on encoder cable	D-sub connector, female for cable \varnothing 8 mm 	315650-14		
			12-pin	9-pin
Mating element on connecting cable to connector on encoder cable	Coupling (female) for cable \varnothing 8 mm 	291698-02	291698-01	
Connector on cable for connection to subsequent electronics	Connector (male) for cable \varnothing 8 mm 	291697-08	291697-04	
Coupling on connecting cable	Coupling (male) for cable \varnothing 8 mm 	291698-04	291698-24	
Flange socket for mounting on the subsequent electronics	Flange socket (female) 	315892-08	315892-06	
Mounted couplings	With flange (female) \varnothing 8 mm 	291698-07	291698-06	
	With flange (male) \varnothing 8 mm 	291698-31	-	
	With central fastening (male) \varnothing 6 mm 	291698-33	-	
Adapter connector \sim 1 V _{PP} /11 μ A _{PP} For converting the 1 V _{PP} signals to 11 μ A _{PP} ; M23 connector (female) 12-pin and M23 connector (male) 9-pin 		364914-01	-	

Connecting Cable

PUR connecting cable for length gauges with D-sub connecting elements (8 mmØ cable)

[4(2 × 0.14 mm ²) + (4 × 0.5 mm ²)]		
Complete with D-sub connector (female), 15-pin and M23 connector (male), 12-pin		331 693-xx
with one D-sub connector (female), 15-pin		332 433-xx
Complete with D-sub connector (female), 15-pin and connector (male), 15-pin For ND 28x		335 074-xx
Complete with D-sub connector (female), 15-pin and connector (female), 15 pin For IK 220, ND 780, POSITIP 880		335 077-xx
Cable without connectors		244 957-01

PUR connecting cable for length gauges with M23 connector (8 mm Øcable)

~ 11 µApp interface	9-pin: [3(2 × 0.14 mm ²) + (2 × 1 mm ²)]		
~ 1 Vpp interface	12-pin: [4(2 × 0.14 mm ²) + (4 × 0.5 mm ²)]		
Complete with M23 coupling (female) and D-sub connector (male), 15-pin For ND 28x		309 784-xx	653 231-xx
Complete with M23 coupling (female) and D-sub connector (female), 15-pin		309 783-xx	368 172-xx
With one connector with M23 coupling (female)		298 402-xx	309 780-xx

General Electrical Information

Power Supply

The encoders require a **stabilized DC voltage U_p** as power supply. The respective *Specifications* state the required power supply and the current consumption. The permissible ripple content of the DC voltage is:

- High frequency interference
 $U_{PP} < 250 \text{ mV}$ with $dU/dt > 5 \text{ V}/\mu\text{s}$
- Low frequency fundamental ripple
 $U_{PP} < 100 \text{ mV}$

The values apply as measured at the encoder, i.e., without cable influences. The voltage can be monitored and adjusted with the encoder's **sensor lines**. If a controllable power supply is not available, the voltage drop can be halved by switching the sensor lines parallel to the corresponding power lines.

Calculation of the **voltage drop**:

$$\Delta U = 2 \cdot 10^{-3} \cdot \frac{L_C \cdot I}{56 \cdot A_P}$$

where ΔU : Voltage attenuation in V
 L_C : Cable length in m
 I : Current consumption in mA
 A_P : Cross section of power lines in mm^2

Switch-on/off behavior of the encoders

The output signals are valid no sooner than after switch-on time $t_{SOT} = 1.3 \text{ s}$ (2 s for PROFIBUS-DP) (see diagram). During time t_{SOT} they can have any levels up to 5.5 V (with HTL encoders up to U_{Pmax}). If an interpolation electronics unit is inserted between the encoder and the power supply, the unit's switch-on/off characteristics must also be considered. If the power supply is switched off, or when the supply voltage falls below U_{min} , the output signals are also invalid. These data apply to the encoders listed in the catalog—customer-specific interfaces are not considered.

Encoders with new features and increased performance range may take longer to switch on (longer time t_{SOT}). If you are responsible for developing subsequent electronics, please contact HEIDENHAIN in good time.

Isolation

The encoder housings are isolated against internal circuits.

Rated surge voltage: 500 V
 (preferred value as per VDE 0110 Part 1, overvoltage category II, contamination 2)

Cable

HEIDENHAIN cables are mandatory for **safety-related applications**. The **cable lengths** listed in the *Specifications* apply only for HEIDENHAIN cables and the recommended input circuitry of subsequent electronics.

Durability

All encoders have polyurethane (PUR) cables. PUR cables are resistant to oil, hydrolysis and microbes in accordance with **VDE 0472**. They are free of PVC and silicone and comply with UL safety directives. The **UL certification** AWM STYLE 20963 80 °C 30 V E63216 is documented on the cable.

Temperature range

HEIDENHAIN cables can be used for

- rigid configuration -40 °C to 80 °C
- frequent flexing -10 °C to 80 °C

Cables with limited resistance to hydrolysis and media are rated for up to 100 °C . If required, please ask for assistance from HEIDENHAIN Traunreut.

Bend radius

The permissible bend radius R depends on the cable diameter and the configuration:

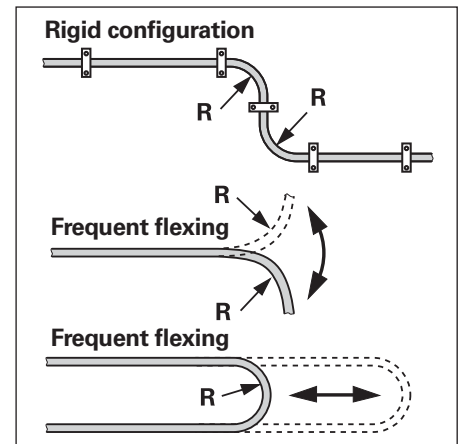
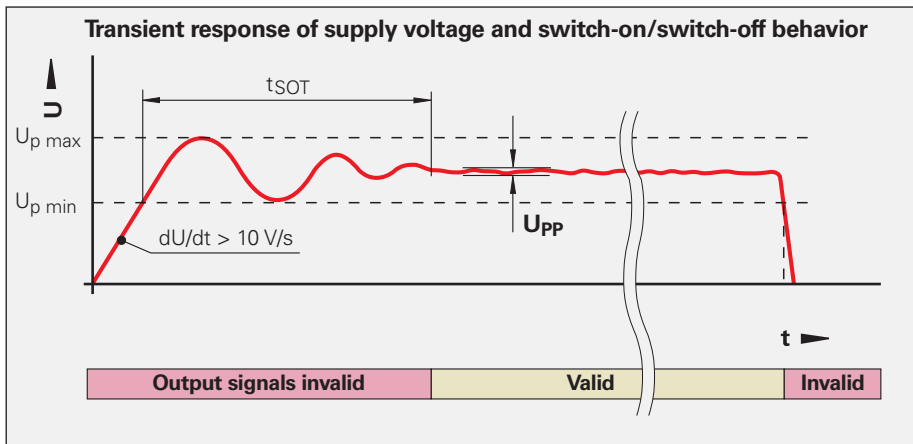

Connect HEIDENHAIN encoders only to subsequent electronics whose power supply is generated from PELV systems (**EN 50178**). In addition, in safety-related applications, overcurrent protection and sometimes overvoltage protection are required.

Cable	Cross section of power supply lines A_P				Bend radius R	
	1 V_{PP} /TTL/HTL	11 μA_{PP}	EnDat/SSI 17-pin	EnDat ⁵⁾ 8-pin	Rigid configuration	Frequent flexing
$\varnothing 3.7 \text{ mm}$	0.05 mm^2	–	–	–	$\geq 8 \text{ mm}$	$\geq 40 \text{ mm}$
$\varnothing 4.3 \text{ mm}$	0.24 mm^2	–	–	–	$\geq 10 \text{ mm}$	$\geq 50 \text{ mm}$
$\varnothing 4.5 \text{ mm}$ $\varnothing 5.1 \text{ mm}$	$0.14/0.09^{2)} \text{ mm}^2$ $0.05^{3)} \text{ mm}^2$	0.05 mm^2	0.05 mm^2	0.14 mm^2	$\geq 10 \text{ mm}$	$\geq 50 \text{ mm}$
$\varnothing 6 \text{ mm}$ $\varnothing 10 \text{ mm}^{1)}$	$0.19/0.14^{4)} \text{ mm}^2$	–	0.08 mm^2	0.34 mm^2	$\geq 20 \text{ mm}$ $\geq 35 \text{ mm}$	$\geq 75 \text{ mm}$ $\geq 75 \text{ mm}$
$\varnothing 8 \text{ mm}$ $\varnothing 14 \text{ mm}^{1)}$	0.5 mm^2	1 mm^2	0.5 mm^2	1 mm^2	$\geq 40 \text{ mm}$ $\geq 100 \text{ mm}$	$\geq 100 \text{ mm}$ $\geq 100 \text{ mm}$

¹⁾ Metal armor ²⁾ Rotary encoders ³⁾ Length gauges ⁴⁾ LIDA 400
⁵⁾ Also Fanuc, Mitsubishi

Electrically Permissible Speed/Traversing Speed

The maximum permissible shaft speed or traversing velocity of an encoder is derived from

- the **mechanically** permissible shaft speed/traversing velocity (if listed in *Specifications*) and
- the **electrically** permissible shaft speed/traversing velocity.

For encoders with **sinusoidal output signals**, the electrically permissible shaft speed/traversing velocity is limited by the $-3\text{dB}/-6\text{dB}$ cutoff frequency or the permissible input frequency of the subsequent electronics.

For encoders with **square-wave signals**, the electrically permissible shaft speed/traversing velocity is limited by

- the maximum permissible scanning frequency f_{max} of the encoder
- the minimum permissible edge separation a for the subsequent electronics.

For angular or rotary encoders

$$n_{\text{max}} = \frac{f_{\text{max}}}{z} \cdot 60 \cdot 10^3$$

For linear encoders

$$v_{\text{max}} = f_{\text{max}} \cdot \text{SP} \cdot 60 \cdot 10^{-3}$$

Where:

n_{max} : Elec. permissible speed in min^{-1}

v_{max} : Elec. permissible traversing velocity in m/min

f_{max} : Max. scanning/output frequency of encoder or input frequency of subsequent electronics in kHz

z : Line count of the angle or rotary encoder per 360°

SP : Signal period of the linear encoder in μm

Noise-Free Signal Transmission

Electromagnetic compatibility/CE compliance

When properly installed, and when HEIDENHAIN connecting cables and cable assemblies are used, HEIDENHAIN encoders fulfill the requirements for electromagnetic compatibility according to 2004/108/EC with respect to the generic standards for:

• Noise immunity EN 61 000-6-2:

Specifically:

- ESD EN 61 000-4-2
- Electromagnetic fields EN 61 000-4-3
- Burst EN 61 000-4-4
- Surge EN 61 000-4-5
- Conducted disturbances EN 61 000-4-6
- Power frequency magnetic fields EN 61 000-4-8
- Pulse magnetic fields EN 61 000-4-9

• Interference EN 61 000-6-4:

Specifically:

- For industrial, scientific and medical equipment (ISM) EN 55 011
- For information technology equipment EN 55 022

Transmission of measuring signals—electrical noise immunity

Noise voltages arise mainly through capacitive or inductive transfer. Electrical noise can be introduced into the system over signal lines and input or output terminals.

Possible sources of noise include:

- Strong magnetic fields from transformers, brakes and electric motors
- Relays, contactors and solenoid valves
- High-frequency equipment, pulse devices, and stray magnetic fields from switch-mode power supplies
- AC power lines and supply lines to the above devices

Protection against electrical noise

The following measures must be taken to ensure disturbance-free operation:

- Use only original HEIDENHAIN cables. Consider the voltage attenuation on supply lines.
- Use connecting elements (such as connectors or terminal boxes) with metal housings. Only the signals of and power supply for the connected encoder may be routed through these elements. Applications in which additional signals are led through the connecting element require specific measures regarding electrical safety and EMC.

- Connect the housings of the encoder, connecting elements and subsequent electronics through the shield of the cable. Ensure that the shield has complete contact over the entire surface (360°). For encoders with more than one electrical connection, refer to the documentation for the respective product.

- For cables with multiple shields, the inner shields must be led separately from the outer shield. Connect inner shield to 0 V of the subsequent electronics. Do not connect the inner shields with the outer shield, neither in the encoder nor in the cable.

- Connect the shield to protective ground as per the mounting instructions.

- Prevent contact of the shield (e.g. connector housing) with other metal surfaces. Pay attention to this when installing cables.

- Do not install signal cables in the direct vicinity of interference sources (inductive consumers such as contacts, motors, frequency inverters, solenoids, etc.).

- Sufficient decoupling from interference-signal-conducting cables can usually be achieved by an air clearance of 100 mm or, when cables are in metal ducts, by a grounded partition.

- A minimum spacing of 200 mm to inductors in switch-mode power supplies is required.

- If compensating currents are to be expected within the overall system, a separate equipotential bonding conductor must be provided. The shield does not have the function of an equipotential bonding conductor.
- Only provide power to position encoders from PELV systems (**EN 50 178**). Provide high-frequency grounding with low impedance (**EN 60204-1 Chap. EMC**).
- For encoders with 11 μA_{PP} interface: For extension cables, use only HEIDENHAIN cable ID 244 955-01. Overall length max. 30 m.

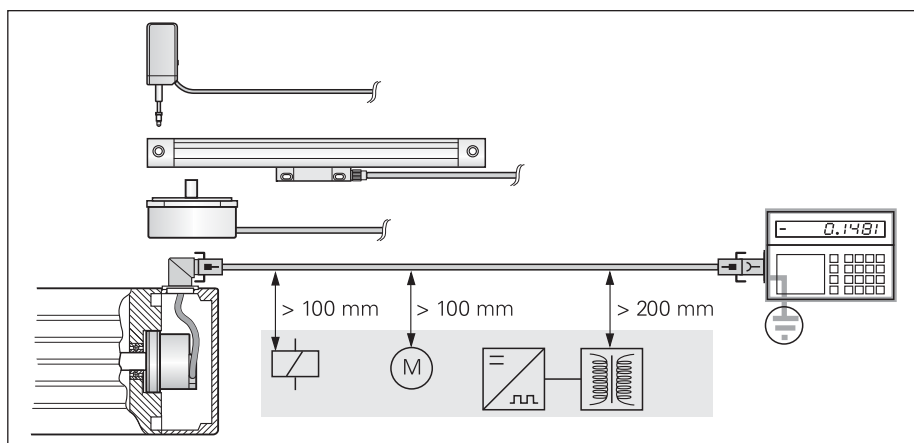

Minimum distance from sources of interference

HEIDENHAIN

DR. JOHANNES HEIDENHAIN GmbH

Dr.-Johannes-Heidenhain-Straße 5
83301 Traunreut, Germany
☎ +49 (8669) 31-0
☎ +49 (8669) 5061
E-mail: info@heidenhain.de

www.heidenhain.de

DE HEIDENHAIN Technisches Büro Nord

12681 Berlin, Deutschland
☎ (030) 54705-240
E-Mail: tbn@heidenhain.de

HEIDENHAIN Technisches Büro Mitte

08468 Heinsdorfergrund, Deutschland
☎ (03765) 69544
E-Mail: tbn@heidenhain.de

HEIDENHAIN Technisches Büro West

44379 Dortmund, Deutschland
☎ (0231) 618083-0
E-Mail: tbw@heidenhain.de

HEIDENHAIN Technisches Büro Südwest

70771 Leinfelden-Echterdingen, Deutschland
☎ (0711) 993395-0
E-Mail: tbsw@heidenhain.de

HEIDENHAIN Technisches Büro Südost

83301 Traunreut, Deutschland
☎ (08669) 31-1345
E-Mail: tbo@heidenhain.de

AR NAKASE SRL.
B1653AOX Villa Ballester, Argentina
☎ +54 (11) 47684242
E-mail: nakase@nakase.com

AT HEIDENHAIN Techn. Büro Österreich
83301 Traunreut, Germany
☎ +49 (8669) 31-1337
E-mail: tba@heidenhain.de

AU FCR Motion Technology Pty. Ltd
Laverton North 3026, Australia
☎ +61 (3) 93626800
E-mail: vicsales@fcrmotion.com

BE HEIDENHAIN NV/SA
1760 Roosdaal, Belgium
☎ +32 (54) 343158
E-mail: sales@heidenhain.be

BG ESD Bulgaria Ltd.
Sofia 1172, Bulgaria
☎ +359 (2) 9632949
E-mail: info@esd.bg

BR DIADUR Indústria e Comércio Ltda.
04763-070 – São Paulo – SP, Brazil
☎ +55 (11) 5696-6777
E-mail: diadur@diadur.com.br

BY Belarus → RU

CA HEIDENHAIN CORPORATION
Mississauga, Ontario L5T 2N2, Canada
☎ +1 (905) 670-8900
E-mail: info@heidenhain.com

CH HEIDENHAIN (SCHWEIZ) AG
8603 Schwerzenbach, Switzerland
☎ +41 (44) 8062727
E-mail: verkauf@heidenhain.ch

CN DR. JOHANNES HEIDENHAIN (CHINA) Co., Ltd.
Beijing 101312, China
☎ +86 10-80420000
E-mail: sales@heidenhain.com.cn

CS Serbia and Montenegro → BG

CZ HEIDENHAIN s.r.o.
106 00 Praha 10, Czech Republic
☎ +420 272658131
E-mail: heidenhain@heidenhain.cz

DK TP TEKNIK A/S
2670 Greve, Denmark
☎ +45 (70) 100966
E-mail: tp-gruppen@tp-gruppen.dk

ES FARRESA ELECTRONICA S.A.
08028 Barcelona, Spain
☎ +34 934092491
E-mail: farresa@farresa.es

FI HEIDENHAIN Scandinavia AB
02770 Espoo, Finland
☎ +358 (9) 8676476
E-mail: info@heidenhain.fi

FR HEIDENHAIN FRANCE sarl
92310 Sèvres, France
☎ +33 0141143000
E-mail: info@heidenhain.fr

GB HEIDENHAIN (G.B.) Limited
Burgess Hill RH15 9RD, United Kingdom
☎ +44 (1444) 247711
E-mail: sales@heidenhain.co.uk

GR MB Milionis Vassilis
17341 Athens, Greece
☎ +30 (210) 9336607
E-mail: bmilioni@otenet.gr

HK HEIDENHAIN LTD
Kowloon, Hong Kong
☎ +852 27591920
E-mail: service@heidenhain.com.hk

HR Croatia → SL

HU HEIDENHAIN Kereskedelmi Képviselet
1239 Budapest, Hungary
☎ +36 (1) 4210952
E-mail: info@heidenhain.hu

ID PT Servitama Era Toolsindo
Jakarta 13930, Indonesia
☎ +62 (21) 46834111
E-mail: ptset@group.gts.co.id

IL NEUMO VARGUS MARKETING LTD.
Tel Aviv 61570, Israel
☎ +972 (3) 5373275
E-mail: neumo@neumo-vargus.co.il

IN HEIDENHAIN Optics & Electronics India Private Limited
Chennai – 600 031, India
☎ +91 (44) 3023-4000
E-mail: sales@heidenhain.in

IT HEIDENHAIN ITALIANA S.r.l.
20128 Milano, Italy
☎ +39 02270751
E-mail: info@heidenhain.it

JP HEIDENHAIN K.K.
Tokyo 102-0073, Japan
☎ +81 (3) 3234-7781
E-mail: sales@heidenhain.co.jp

KR HEIDENHAIN LTD.
Gasam-Dong, Seoul, Korea 153-782
☎ +82 (2) 2028-7430
E-mail: info@heidenhain.co.kr

MK Macedonia → BG

MX HEIDENHAIN CORPORATION MEXICO
20235 Aguascalientes, Ags., Mexico
☎ +52 (449) 9130870
E-mail: info@heidenhain.com

MY ISOSERVE Sdn. Bhd
56100 Kuala Lumpur, Malaysia
☎ +60 (3) 91320685
E-mail: isoserve@po.jaring.my

NL HEIDENHAIN NEDERLAND B.V.
6716 BM Ede, Netherlands
☎ +31 (318) 581800
E-mail: verkoop@heidenhain.nl

NO HEIDENHAIN Scandinavia AB
7300 Orkanger, Norway
☎ +47 72480048
E-mail: info@heidenhain.no

PH Machinebanks Corporation
Quezon City, Philippines 1113
☎ +63 (2) 7113751
E-mail: info@machinebanks.com

PL APS
02-489 Warszawa, Poland
☎ +48 228639737
E-mail: aps@apserwis.com.pl

PT FARRESA ELECTRÓNICA, LDA.
4470 - 177 Maia, Portugal
☎ +351 229478140
E-mail: fep@farresa.pt

RO Romania → HU

RU OOO HEIDENHAIN
125315 Moscow, Russia
☎ +7 (495) 931-9646
E-mail: info@heidenhain.ru

SE HEIDENHAIN Scandinavia AB
12739 Skärholmen, Sweden
☎ +46 (8) 53193350
E-mail: sales@heidenhain.se

SG HEIDENHAIN PACIFIC PTE LTD.
Singapore 408593,
☎ +65 6749-3238
E-mail: info@heidenhain.com.sg

SK Slovakia → CZ

SL Posredništvo HEIDENHAIN NAVO d.o.o.
2000 Maribor, Slovenia
☎ +386 (2) 4297216
E-mail: hubl@siol.net

TH HEIDENHAIN (THAILAND) LTD
Bangkok 10250, Thailand
☎ +66 (2) 398-4147-8
E-mail: info@heidenhain.co.th

TR T&M Mühendislik San. ve Tic. LTD. ŞTİ.
34728 Ümraniye-Istanbul, Turkey
☎ +90 (216) 314 1111
E-mail: info@tmmuhendislik.com.tr

TW HEIDENHAIN Co., Ltd.
Taichung 40768, Taiwan R.O.C.
☎ +886 (4) 23588977
E-mail: info@heidenhain.tw

UA Ukraine → RU

US HEIDENHAIN CORPORATION
Schaumburg, IL 60173-5337, USA
☎ +1 (847) 490-1191
E-mail: info@heidenhain.com

VE Maquinaria Diekmann S.A.
Caracas, 1040-A, Venezuela
☎ +58 (212) 6325410
E-mail: purchase@diekmann.com.ve

VN AMS Advanced Manufacturing Solutions Pte Ltd
HCM City, Viêt Nam
☎ +84 (8) 9123658 - 8352490
E-mail: davidgoh@amsvn.com

ZA MAFEMA SALES SERVICES C.C.
Midrand 1685, South Africa
☎ +27 (11) 3144416
E-mail: mailbox@mafema.co.za

