



HEIDENHAIN



General Catalog

Linear Encoders
Length Gauges
Angle Encoders
Rotary Encoders
Contouring Controls
3-D Touch Probes
Digital Readouts

October 2009

DR. JOHANNES HEIDENHAIN GmbH develops and manufactures linear and angular encoders, rotary encoders, digital readouts, and numerical controls.

HEIDENHAIN supplies its products to manufacturers of machine tools, and of automated machines and systems, in particular for semiconductor and electronics manufacturing.

HEIDENHAIN is represented in over 50 countries—mainly through its own subsidiaries. Sales engineers and service technicians support the user on-site with technical information and servicing.

This General Catalog offers you an overview of the HEIDENHAIN product program. You will find more products and further information in the documentation for specific products (see page 60) or on the Internet at www.heidenhain.de. Our sales personnel will be glad to help you personally. See page 62 for addresses and telephone numbers.



Contents

Fundamentals and Processes	4
Precision Graduations—the Foundation for High Accuracy	5
Length Measurement Sealed Linear Encoders Exposed Linear Encoders Length Gauges	6
Angle Measurement Angle Encoders Modular Encoders Rotary Encoders	20
Machine Tool Control Contouring Controls for Milling Machines and Machining Centers Programming Station	38
Tool and Workpiece Setup and Measurement Workpiece Touch Probes Tool Touch Probes	47
Measured Value Acquisition and Display Position Display Units Interface Electronics	50
More Information	56
Support and Service	58

Fundamentals and Processes

The high quality of HEIDENHAIN products presupposes special production facilities and measuring equipment. Masters and submasters for scale manufacturing are produced in a clean room with special measures for temperature stabilization and vibration insulation. The copying machines and the machines required for the manufacture and measurement of linear and circular graduations are largely developed and built by HEIDENHAIN.



Measuring machine for linear scales



Linear scale inspection station

Our competence in the area of linear and angular metrology is reflected by a large number of customized solutions for users. Among other implementations, they include the measuring and test equipment developed and built for standard laboratories and the angular encoders for telescopes and satellite receiving antennas. Of course the products in the standard HEIDENHAIN product program profit from the knowledge gained.



Angle comparator, measuring step approx. 0.001"



Very Large Telescope (VLT), Paranal, Chile (photograph by ESO)

Precision Graduations—the Foundation for High Accuracy

The heart of a HEIDENHAIN encoder is its measuring standard, usually in the form of a grating with typical line widths of $0.25\ \mu\text{m}$ to $10\ \mu\text{m}$. These precision graduations are manufactured in a process invented by HEIDENHAIN (e.g. DIADUR or METALLUR) and are a decisive factor in the function and accuracy of encoders. The graduations consist of lines and gaps at defined intervals with very little deviation, forming structures with very high edge definition. These graduations are resistant to mechanical and chemical influences as well as to vibration and shock. All graduations have a defined thermal behavior.

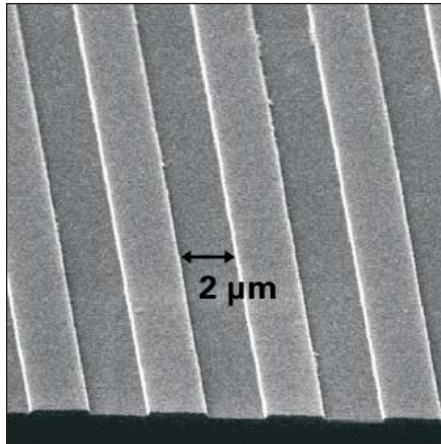

Phase grating with approx. $0.25\ \mu\text{m}$ grating height

DIADUR

DIADUR precision graduations are composed of an extremely thin layer of chromium on a substrate—usually of glass or glass ceramic. The accuracy of the graduation structure lies within the micron and submicron range.

AURODUR

AURODUR graduations consists of highly reflective gold lines and matte etched gaps. AURODUR graduations are usually on steel carriers.

METALLUR

With its special optical composition of reflective gold layers, METALLUR graduations show a virtually planar structure. They are therefore particularly tolerant to contamination.

Phase gratings

Special manufacturing processes make it possible to produce three-dimensional graduation structures, possessing certain optical characteristics. The structure widths are in the range of a few microns down to quarters of a micron.

SUPRADUR

Graduations manufactured with the SUPRADUR process function optically like three-dimensional phase gratings, but they have a planar structure and are therefore particularly insensitive to contamination.

MAGNODUR

Thin magnetically active layers in the micron range are structured for very fine, magnetized graduations.

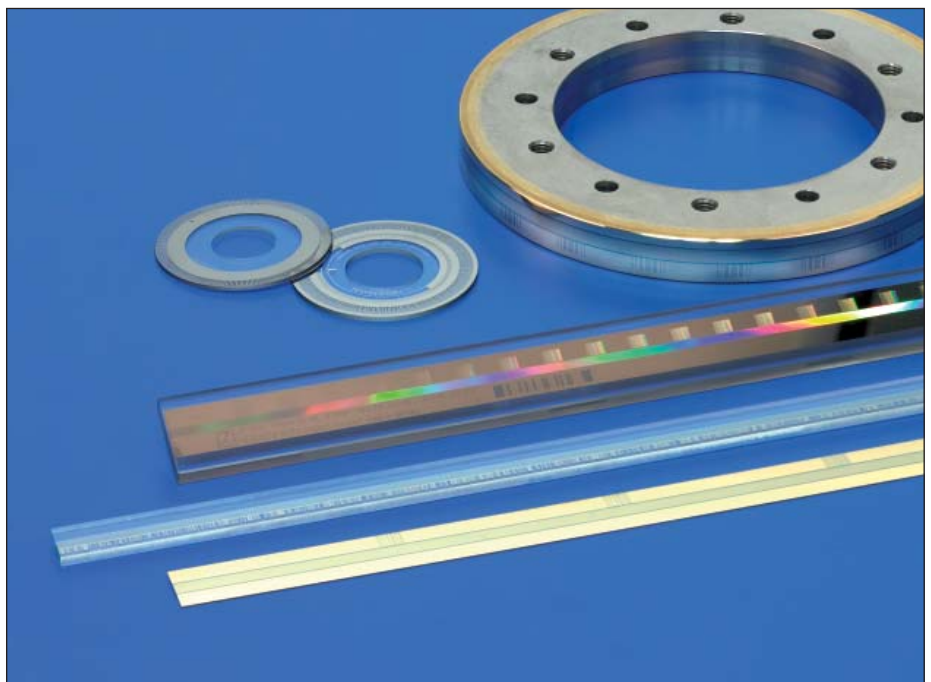

DIADUR and AURODUR graduations on various carrier materials

Length Measurement

Sealed linear encoders

Sealed linear encoders from HEIDENHAIN are protected from dust, chips and splash fluids and are ideal for operation on **machine tools**.

- Accuracy grades as fine as $\pm 2 \mu\text{m}$
- Measuring steps to $0.005 \mu\text{m}$
- Measuring lengths up to 30 m
- Fast and simple installation
- Large mounting tolerances
- High acceleration loading
- Protection against contamination



Sealed linear encoders are available with

- **Full-size scale housing**
 - For high vibration loading
 - Up to 30 m measuring length
- **Slimline scale housing**
 - For limited installation space
 - Up to 1240 mm measuring length, up to 2040 mm with mounting spar or tensioning elements

The aluminum housing of a HEIDENHAIN sealed linear encoder protects the scale, scanning carriage, and its guideway from chips, dust, and fluids. Downward-oriented elastic lips seal the housing.

The scanning carriage travels along the scale on a low-friction guide. It is connected to the external mounting block by a coupling that compensates unavoidable misalignment between the scale and the machine guideways.

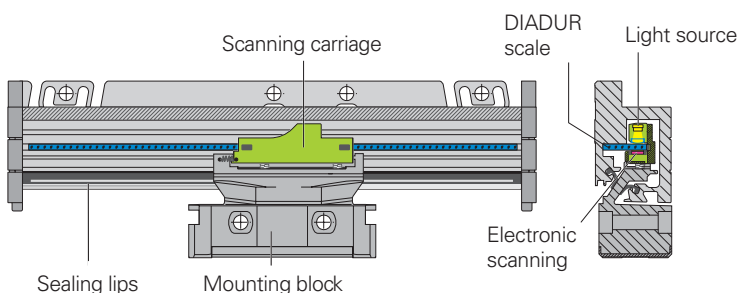

Exposed linear encoders

Exposed linear encoders from HEIDENHAIN operate with no mechanical contact between the scanning head and the scale or scale tape. Typical areas of application for these encoders include **measuring machines, comparators** and other **precision devices** in linear metrology, as well as **production and measuring equipment**, for example in the semiconductor industry.

- Accuracy grades of $\pm 0.5 \mu\text{m}$ and better
- For measuring steps to $0.001 \mu\text{m}$ (1 nm)
- Measuring lengths up to 30 m
- No friction between scanning head and scale
- Small dimensions and low weight
- High traversing speed

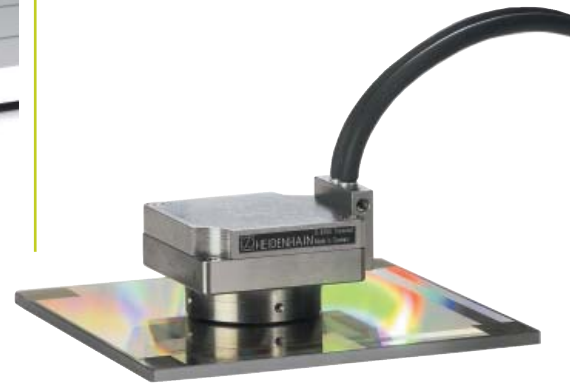

Length gauges

Length gauges from HEIDENHAIN feature integral guideways for the plunger.

They are used to monitor measuring equipment, in industrial metrology, and also as position encoders.

- Accuracy grades as fine as $\pm 0.1 \mu\text{m}$
- For measuring steps to $0.005 \mu\text{m}$ (5 nm)
- Measuring lengths up to 100 mm
- High measuring accuracy
- Available with automated plunger drive
- Simple mounting

With **incremental linear encoders**, the current position is determined by starting at a datum and counting measuring steps, or by subdividing and counting signal periods. Incremental encoders from HEIDENHAIN feature reference marks, which must be scanned after switch-on to reestablish the reference point. This process is especially simple and fast with distance-coded reference marks.

Absolute linear encoders from HEIDENHAIN require no previous traverse to provide the current position value. The encoder transmits the absolute value through the **EnDat interface** or another serial interface.

The recommended **measuring steps** listed in the table refer primarily to position measurements. Smaller measuring steps are useful in particular for applications in rotational speed control, e.g. on direct drives. The sinusoidal output signals make it possible to attain higher interpolation factors.

Under the designation **functional safety**, HEIDENHAIN offers encoders with purely serial data transmission as single-encoder systems for safety-related machines and systems. The two measured values are already formed independently of each other in the encoder, and are transmitted to the safe control via the EnDat interface.



Sealed Linear Encoders

With full-size scale housing

Absolute position measurement
Incremental position measurement
Very high repeatability
Typically for manual machines
Large measuring lengths

Series

LC 100
LS 100
LF 100
LS 600
LB 300

Page

8

With slimline scale housing

Absolute position measurement
Incremental position measurement
Very high repeatability
Typically for manual machines

LC 400
LS 400
LF 400
LS 300

10

Exposed Linear Encoders

Accuracy grades better than $\pm 3 \mu\text{m}$
Two-coordinate encoders
Accuracy grade as fine as $\pm 5 \mu\text{m}$

LIP, LIF
PP
LIDA

12

13

14

Length Gauges

Accuracy $\pm 0.1 \mu\text{m}$
Accuracy $\pm 0.2 \mu\text{m}$
Accuracy to $\pm 0.5 \mu\text{m}$
Accuracy $\pm 1 \mu\text{m}$

HEIDENHAIN-CERTO
HEIDENHAIN-METRO
HEIDENHAIN-METRO
HEIDENHAIN-SPECTO

16

17

18

19

LC, LF, LS, LB Sealed Linear Encoders With Full-Size Scale Housing

Linear encoders with **full-size scale housing** are characterized particularly by high tolerance to vibration.

Absolute linear encoders of the **LC 100** series provide the **absolute position value** without any previous traverse required. Incremental signals can also be provided. They can be mounted to the same mating dimensions as the incremental linear encoders of the **LS 100** series and feature the same mechanical design. Because of their high accuracy and defined thermal behavior, LC 100 and LS 100 series linear encoders are especially well suited for use on **numerically controlled machine tools**.

The incremental encoders of the **LF** type feature measuring standards with relatively fine grating periods. This makes them particularly attractive for applications requiring very **high repeatability**.

The **LS 600** series incremental linear encoders are used for simple positioning tasks, for example on **manual machine tools**.

The **LB** type of incremental linear encoders were conceived for very **long measuring lengths up to 30 meters**. Their measuring standard—a steel tape with AURODUR graduation—is delivered as a single piece, and after the housing sections have been mounted, is pulled into the housing, drawn to a defined tension and fixed at both ends to the machine casting.

LC 100 series

- **Absolute position measurement**
- Defined thermal behavior
- High vibration rating
- Two mounting attitudes
- Single-field scanning

LS 187

- **Incremental position measurement**
- Defined thermal behavior
- High vibration rating
- Two mounting attitudes
- Single-field scanning

LF 183

- **Very high repeatability**
- Thermal behavior similar to steel or cast iron
- High vibration rating
- Two mounting attitudes
- Single-field scanning

LS 600 series

- **Typically for manual machines**
- Simple installation

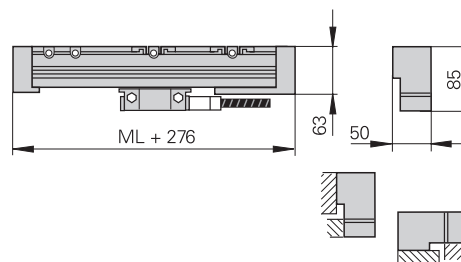

LB 382

- **For large measuring lengths** up to 30 m
- Defined thermal behavior
- High vibration rating
- Two mounting attitudes
- Single-field scanning

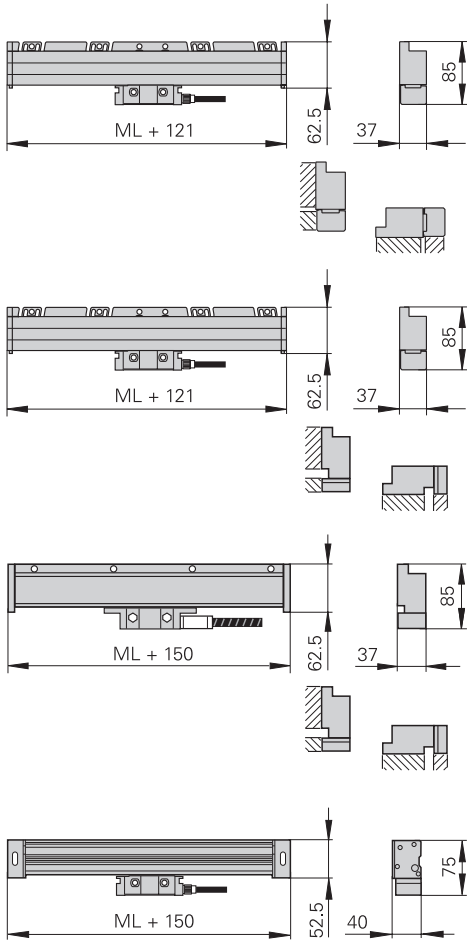

	Absolute	Incremental			
	LC 183 LC 193 F/M	LF 183	LS 187 LS 177	LS 688C LS 628C	LB 382
Measuring standard	DIADUR glass scale	DIADUR phase grating on steel	DIADUR glass scale	DIADUR glass scale	AURODUR steel scale tape
Incremental signals	Optional for LC 183	$\sim 1 V_{PP}$	LS 187: $\sim 1 V_{PP}$ LS 177: \square TTL	LS 688C: $\sim 1 V_{PP}$ LS 628C: \square TTL	$\sim 1 V_{PP}$
Signal period	20 μm	4 μm	20 μm LS 177: 4 μm /2 μm	20 μm	40 μm
Absolute position values	EnDat 2.2 Fanuc/Mitsubishi	-			
Accuracy grade	$\pm 5 \mu m, \pm 3 \mu m$	$\pm 3 \mu m, \pm 2 \mu m$	$\pm 5 \mu m, \pm 3 \mu m$	$\pm 10 \mu m$	$\pm 5 \mu m$
Recommended measuring step	0.05 to 0.005 μm ¹⁾	1 to 0.1 μm	1 to 0.1 μm	LS 688C: up to 1 μm LS 628C: 5 μm	10 to 0.1 μm
Measuring lengths ML	140 to 4240 mm ($\pm 3 \mu m$ to 3040 mm)	140 to 3040 mm		170 to 3040 mm	440 to 30040 mm
Reference mark	-	One or distance-coded; LS 6xx C: distance-coded			

¹⁾ Absolute position values

LC, LF, LS Sealed Linear Encoders With Slimline Scale Housing

Sealed linear encoders with **slimline scale housing** are primarily used where installation space is limited.

Absolute linear encoders of the **LC 400** series provide the **absolute position value** without any previous traverse required. Incremental signals can also be provided. Like the **LS 400** series incremental linear encoders, their high accuracy and defined thermal behavior make them especially well suited for use on **numerically controlled machine tools**.

The incremental encoders of the **LF** type feature measuring standards with relatively fine grating periods. This makes them particularly attractive for applications requiring very **high repeatability**.

The **LS 300** series incremental linear encoders are used for simple positioning tasks, for example on **manual machine tools**.

LC 400 series

- **Absolute position measurement**
- Defined thermal behavior
- Single-field scanning

LS 487

- **Incremental position measurement**
- Defined thermal behavior
- Single-field scanning

LF 481

- **Very high repeatability**
- Thermal behavior similar to steel or cast iron
- Single-field scanning

LS 300 series

- **Typically for manual machines**

Simple installation with mounting spar

The use of a mounting spar can be of great benefit when mounting slimline linear encoders. They can be fastened as part of the machine assembly process. The encoder is then simply clamped on during final mounting. Easy exchange also facilitates servicing. Moreover, installation with a mounting spar significantly improves the encoder's acceleration behavior.

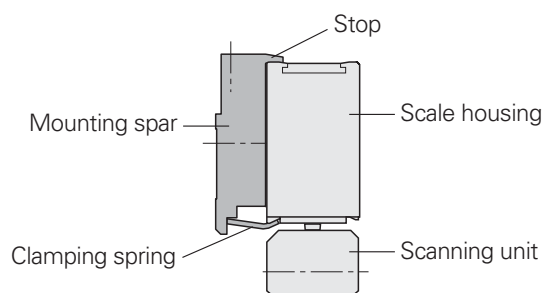

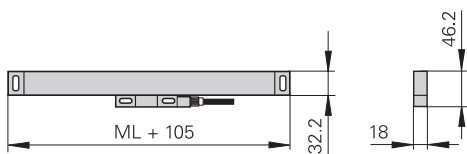
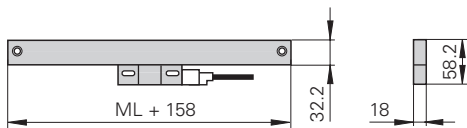
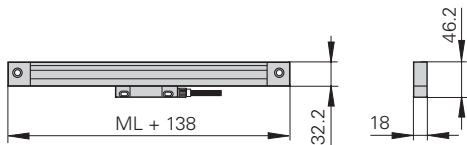
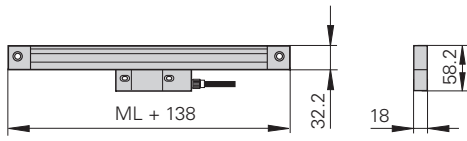

	Absolute	Incremental		
	LC 483 LC 493F/M	LF 481	LS 487 LS 477	LS 388C LS 328C
Measuring standard	DIADUR glass scale	DIADUR phase grating on steel	DIADUR glass scale	DIADUR glass scale
Incremental signals	Optional for LC 483	~ 1 V _{PP}	LS 487: ~ 1 V _{PP} LS 477: □□TTL	LS 388C: ~ 1 V _{PP} LS 328C: □□TTL
Signal period	20 μm	4 μm	20 μm LS 477: 4 μm/2 μm	20 μm
Absolute position values	EnDat 2.2 Fanuc/Mitsubishi	-		
Accuracy grade	± 5 μm, ± 3 μm	± 5 μm, ± 3 μm		± 10 μm
Recommended measuring step	0.05 to 0.005 μm ¹⁾	1 to 0.1 μm	1 to 0.1 μm	LS 388C: up to 1 μm LS 328C: 5 μm
Meas. lengths ML	70 to 2040 mm ²⁾	50 to 1220 mm	70 to 2040 mm ²⁾	70 to 1240 mm
Reference mark	-	One or distance-coded		Distance-coded

¹⁾ Absolute position values ²⁾ over ML 1240 mm only with mounting spar or tensioning element

LIP, LIF Exposed Linear Encoders

Accuracy Grades Better than $\pm 3 \mu\text{m}$

The exposed linear encoders of the **LIP** and **LIF** types are characterized by small measuring steps together with high accuracy. The measuring standard is a phase grating applied to a substrate of glass or glass ceramic.

LIP and **LIF** encoders are typically used for:

- Measuring machines and comparators
- Measuring microscopes
- Ultra-precision machines such as diamond lathes for optical components, facing lathes for magnetic storage disks, and grinding machines for ferrite components
- Measuring and production equipment in the semiconductor industry
- Measuring and production equipment in the electronics industry

LIP 300 series

- **Very high resolution** with measuring steps to 1 nanometer
- Very high repeatability through an extremely fine signal period
- Defined thermal behavior thanks to a measuring standard on Zerodur® glass ceramic

LIP 400 series

- Small dimensions
- Measuring steps to $0.005 \mu\text{m}$
- Scale available with various thermal expansion coefficients

LIP 500 series

- Measuring lengths up to 1 440 mm
- Measuring steps to $0.05 \mu\text{m}$

LIF 400 series

- **Fast, simple scale fastening** with PRECIMET adhesive film
- Relatively insensitive to contamination thanks to SUPRADUR graduation
- Position detection through limit switches and homing track



ML = 70 mm

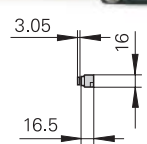
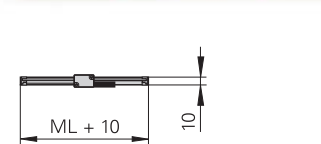
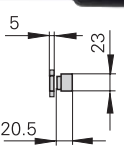
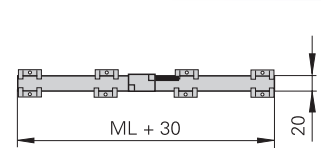
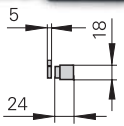
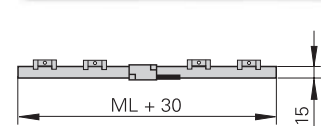
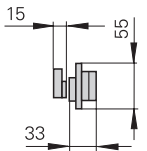
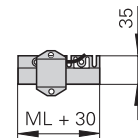

	Incremental		
	LIP 382 LIP 372	LIP 481 LIP 471	LIP 581 LIP 571
Measuring standard	DIADUR phase grating on Zerodur glass ceramic	DIADUR phase grating on glass or Zerodur® glass ceramic	DIADUR phase grating on glass
Expansion coefficient	$\alpha_{\text{therm}} \approx (0 \pm 0.1) \times 10^{-6} \text{ K}^{-1}$	$\alpha_{\text{therm}} \approx 8 \times 10^{-6} \text{ K}^{-1}$ (glass) or $\alpha_{\text{therm}} \approx (0 \pm 0.1) \times 10^{-6} \text{ K}^{-1}$ (Zerodur)	$\alpha_{\text{therm}} \approx 8 \times 10^{-6} \text{ K}^{-1}$
Incremental signals	LIP 382: $\sim 1 \text{ V}_{\text{PP}}$ LIP 372: \square TTL	LIP 481: $\sim 1 \text{ V}_{\text{PP}}$ LIP 471: \square TTL	LIP 581: $\sim 1 \text{ V}_{\text{PP}}$ LIP 571: \square TTL
Signal period	LIP 382: $0.128 \mu\text{m}$ LIP 372: $0.004 \mu\text{m}$	LIP 481: $2 \mu\text{m}$ LIP 471: $0.4 \mu\text{m}/0.2 \mu\text{m}$	LIP 581: $4 \mu\text{m}$ LIP 571: $0.8 \mu\text{m}/0.4 \mu\text{m}$
Accuracy grade	$\pm 0.5 \mu\text{m}^1$	$\pm 1 \mu\text{m}; \pm 0.5 \mu\text{m}^1$	$\pm 1 \mu\text{m}$
Recommd. meas. step	1 nm	$1 \mu\text{m}$ to $0.005 \mu\text{m}$	$1 \mu\text{m}$ to $0.05 \mu\text{m}$
Measuring lengths ML	70 to 270 mm	70 to 420 mm	70 to 1440 mm
Reference mark	None	One	One or distance-coded

¹⁾ Other accuracy grades available on request

PP Exposed Linear Encoders

Two-Coordinate Encoders



The **PP** two-coordinate encoders feature as measuring standard a planar phase-grating structure on a glass substrate. This makes it possible to measure positions in a plane.

Applications include:

- Measuring and production equipment in the semiconductor industry
- Measuring and production equipment in the electronics industry
- Extremely fast X-Y tables
- Measuring machines and comparators
- Measuring microscopes

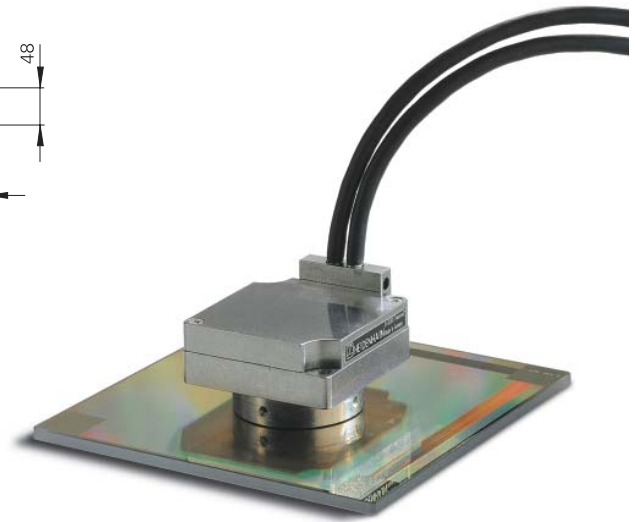
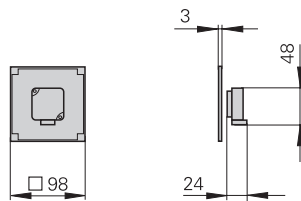

LIF 481 LIF 471
SUPRADUR phase grating on glass $\alpha_{\text{therm}} \approx 8 \times 10^{-6} \text{ K}^{-1}$
LIF 481: $\sim 1 \text{ V}_{\text{PP}}$ LIF 471: \square TTL
LIF 481: 4 μm LIF 471: 0.8 μm to 0.04 μm
$\pm 3 \mu\text{m}$
1 μm to 0.1 μm
70 to 1020 mm (up to 3040 mm on request)
One

	Incremental PP 281 PP 271
Measuring standard Coefficient of linear expansion	DIADUR phase grating on glass $\alpha_{\text{therm}} \approx 8 \times 10^{-6} \text{ K}^{-1}$
Incremental signals	PP 281: $\sim 1 \text{ V}_{\text{PP}}$ PP 271: \square TTL
Signal period	PP 281: 4 μm PP 271: 0.8 μm /0.4 μm
Accuracy grade	$\pm 2 \mu\text{m}$
Recommd. meas. step	To 0.01 μm
Measuring range	68 mm x 68 mm (other measuring ranges upon request)
Reference mark	One per coordinate

LIDA Exposed Linear Encoders

Accuracy Grades to $\pm 5 \mu\text{m}$

The **LIDA** exposed linear encoders are specially designed for **high traversing speeds** up to 10 m/s, and are particularly easy to mount with various mounting possibilities. Steel scale tapes, glass or glass ceramic are used as carriers for METALLUR graduations, depending on the respective encoder.

LIDA exposed linear encoders are typically used for:

- Coordinate measuring machines
- Testing machines
- PCB assembly machines
- PCB drilling machines
- Precision handling devices
- Position and velocity measurement on linear motors

LIDA 403 series

- **Thermal adaptation** through graduation carriers with different coefficients of expansion
- Scale cemented to mounting surface
- Limit switches

LIDA 405 series

- **For large measuring lengths** up to 30 m
- One-piece steel scale tape drawn into an aluminum extrusion and tensioned at its ends
- Limit switches

LIDA 407 series

- **Fast, simple scale fastening** of the aluminum extrusion with PRECIMET adhesive film
- One-piece steel scale tape drawn into an aluminum extrusion and fixed at center
- Limit switches

LIDA 207 series

- **Scale tape cut from roll**
- **Fast, simple scale fastening** of the aluminum extrusion with PRECIMET adhesive film
- One-piece steel scale tape drawn into an aluminum extrusion and fixed at center

LIDA 209 series

- **Scale tape cut from roll**
- One-piece steel scale with PRECIMET mounting adhesive film **cemented on mounting surface**

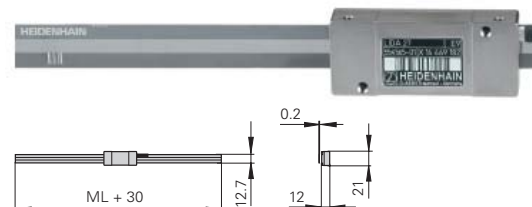
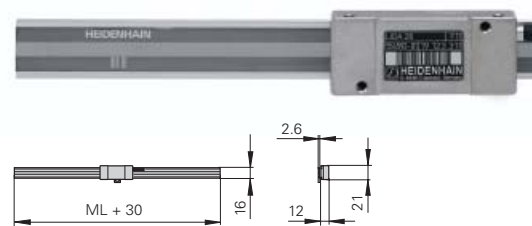
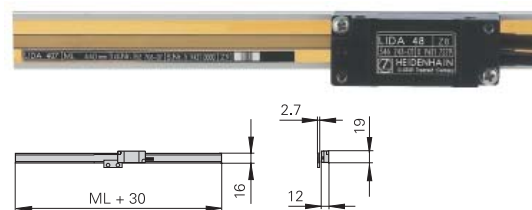
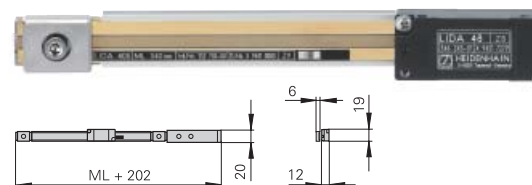
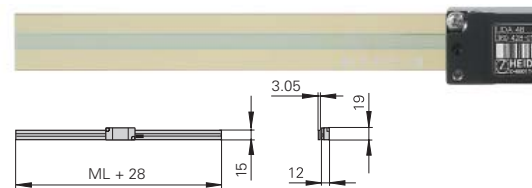

	Incremental		
	LIDA 483 LIDA 473	LIDA 485 LIDA 475	LIDA 487 LIDA 477
Measuring standard Coefficient of linear expansion	METALLUR graduation on glass ceramic or glass $\alpha_{\text{therm}} \approx 8 \times 10^{-6} \text{ K}^{-1}$ (glass) $\alpha_{\text{therm}} \approx 0 \times 10^{-6} \text{ K}^{-1}$ (Robax glass ceramic) $\alpha_{\text{therm}} \approx (0 \pm 0.1) \times 10^{-6} \text{ K}^{-1}$ (Zerodur glass ceramic)	METALLUR steel scale tape $\alpha_{\text{therm}} \approx 10 \times 10^{-6} \text{ K}^{-1}$	
Incremental signals	LIDA 483: $\sim 1 \text{ V}_{\text{PP}}$ LIDA 473: $\square \sqcup \text{TTL}$	LIDA 48x: $\sim 1 \text{ V}_{\text{PP}}$ LIDA 47x: $\square \sqcup \text{TTL}$	
Signal period	LIDA 483: 20 μm LIDA 473: 4 $\mu\text{m}/2 \mu\text{m}/0.4 \mu\text{m}/0.2 \mu\text{m}$	LIDA 48x: 20 μm LIDA 47x: 4 $\mu\text{m}/2 \mu\text{m}/0.4 \mu\text{m}/0.2 \mu\text{m}$	
Accuracy grade	$\pm 5 \mu\text{m}$	$\pm 5 \mu\text{m}$	$\pm 15 \mu\text{m}$
Recommd. meas. step	1 μm to 0.1 μm	1 μm to 0.1 μm	
Measuring lengths ML	240 to 3040 mm (Robax glass ceramic to 1640 mm)	140 to 30040 mm	240 to 6040 mm
Reference mark	One (distance-coded upon request)	One	



The exposed linear encoders of the **LIDA 503** series are specially designed for limited installation space. They consist of a compact scanning head and a glass scale that is simply cemented directly to the machine with PRECIMET adhesive film.

The LIDA 503 is used wherever space is insufficient for encoders of the LIDA 400 series, such as on:

- XY tables
- Measuring microscopes
- PCB assembly machines
- Compact positioning units

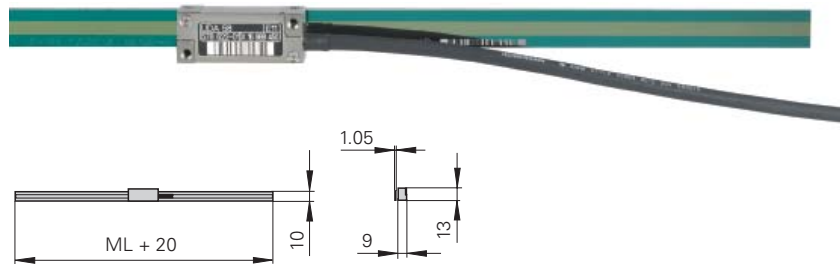

LIDA 287 LIDA 277	LIDA 289 LIDA 279
Steel scale tape $\alpha_{\text{therm}} \approx 10 \times 10^{-6} \text{ K}^{-1}$	
LIDA 28x: $\sim 1 \text{ V}_{\text{PP}}$ LIDA 27x: \square TTL	
LIDA 28x: 200 μm LIDA 27x: 20 $\mu\text{m}/4 \mu\text{m}/2 \mu\text{m}$	
$\pm 30 \mu\text{m}$	
5 μm to 0.5 μm	
Scale tape from the roll 3 m/5 m/10 m	
Selectable every 100 mm	

	Incremental LIDA 583 LIDA 573
Measuring standard Coefficient of linear expansion	METALLUR graduation on glass $\alpha_{\text{therm}} \approx 8 \times 10^{-6} \text{ K}^{-1}$
Incremental signals	LIDA 583: $\sim 1 \text{ V}_{\text{PP}}$ LIDA 573: \square TTL
Signal period	LIDA 583: 20 μm LIDA 573: 4 $\mu\text{m}/2 \mu\text{m}/0.8 \mu\text{m}/0.4 \mu\text{m}$
Accuracy grade	$\pm 5 \mu\text{m}$
Recommd. meas. step	1 μm to 0.1 μm
Measuring lengths ML	70 to 1020 mm
Reference mark	One

HEIDENHAIN-CERTO Length Gauges

Accuracy $\pm 0.1 \mu\text{m}$

HEIDENHAIN-CERTO length gauges feature a large measuring range, provide high linear accuracy and offer resolution in the nanometer range. They are used predominantly for production quality control of high-precision parts and for the monitoring and calibration of reference standards. Length gauges reduce the number of working standards required to calibrate gauge blocks.

Accuracy

The total error of HEIDENHAIN-CERTO length gauges lies within $\pm 0.1 \mu\text{m}$. After linear length error compensation in the evaluation electronics of the ND 28x, HEIDENHAIN guarantees accuracy of $\pm 0.03 \mu\text{m}$ for the CT 2500 and $\pm 0.05 \mu\text{m}$ for the CT 6000. These accuracy grades apply over the entire measuring range at ambient temperatures between 19 and 21 °C and with a temperature variation of $\pm 0.1 \text{ K}$ during measurements for which the HEIDENHAIN-CERTO's CS 200 gauge stand is used.

Plunger actuation

The plungers of the **CT 2501** and **CT 6001** are extended and retracted by an integral motor. It can be actuated by the associated switch box, which can also be controlled by external signal.

The **CT 2502** and **CT 6002** have no plunger drive. The freely movable plunger is connected by a separate coupling with the moving machine element.

Mounting

The CT 2500 length gauge is fastened by its 16 mm diameter clamping shank. The CT 6000 is fastened with two screws on a plane surface.



	Incremental			
	CT 2501	CT 2502	CT 6001	CT 6002
Measuring standard	DIADUR phase grating on Zerodur glass ceramic Coefficient of linear expansion: $\alpha_{\text{therm}} \approx 0 \pm 0.1 \times 10^{-6} \text{ K}^{-1}$			
Incremental signals	$\sim 11 \mu\text{APP}$			
Signal period	2 μm			
System accuracy¹⁾	$\pm 0.1 \mu\text{m}$ $\pm 0.03 \mu\text{m}^2$		$\pm 0.1 \mu\text{m}$ $\pm 0.05 \mu\text{m}^2$	
Recommd. measuring step	0.01 μm and 0.005 μm with the ND 28x measured value display units			
Measuring range	25 mm		60 mm	
Plunger actuation	Motor driven	Via coupling	Motor driven	Via coupling
Reference mark	One			

¹⁾ At 19 °C to 21 °C; permissible temperature fluctuation during measurement: $\pm 0.1 \text{ K}$

²⁾ With linear length-error compensation in the evaluation electronics

HEIDENHAIN-METRO Length Gauges

Accuracy $\pm 0.2 \mu\text{m}$

With their high system accuracy and small signal period, the HEIDENHAIN-METRO MT 1200 and MT 2500 length gauges are ideal for precision measuring stations and testing equipment. They feature ball-bush guided plungers and therefore permit high radial forces.

Plunger actuation

The length gauges of the **MT 12x1** and **MT 25x1** series feature a spring-tensioned plunger that is extended at rest. In a special version without spring it exercises particularly low force on the measured object.

In the pneumatic length gauges **MT 1287** and **MT 2587** the plunger is retracted to its rest position by the integral spring. It is extended to the measuring position by application of compressed air.

Mounting

The MT 1200 and MT 2500 length gauges are fastened by their 8h6 standard clamping shank. A mounting bracket is available as an accessory to mount the length gauges to plane surfaces or to the MS 200 from HEIDENHAIN.



	Incremental			
	MT 1281 MT 1287	MT 1271	MT 2581 MT 2587	MT 2571
Measuring standard	DIADUR phase grating on Zerodur glass ceramic Coefficient of linear expansion: $\alpha_{\text{therm}} \approx 0 \pm 0.1 \times 10^{-6} \text{ K}^{-1}$			
Incremental signals	$\sim 1 \text{ V}_{\text{PP}}$	$\square \text{ TTL}$	$\sim 1 \text{ V}_{\text{PP}}$	$\square \text{ TTL}$
Signal period	2 μm	0.4 μm , or 0.2 μm	2 μm	0.4 μm , or 0.2 μm
System accuracy	$\pm 0.2 \mu\text{m}$			
Recommended measuring step	0.5 μm to 0.05 μm			
Measuring range	12 mm		25 mm	
Plunger actuation	<i>MT 12x1/MT 25x1</i> : by cable-type lifter or freely movable <i>MT 1287/MT 2587</i> : pneumatic			
Reference mark	One			

HEIDENHAIN-METRO Length Gauges

Accuracy $\pm 0.5 \mu\text{m}$

Large measuring ranges together with their high accuracy make the MT 60 and MT 101 HEIDENHAIN-METRO length gauges attractive for incoming inspection, production monitoring, quality control, or anywhere parts with very different dimensions are measured. But they are also easy to mount as highly accurate position encoders, for example on sliding devices or X-Y tables.

Plunger actuation

M version length gauges feature an integral motor that retracts and extends the plunger. While the MT 101 M operates at a constant gauging force, the MT 60 M allows you to select from three gauging force levels.

K version gauges have no integral plunger actuation. The plunger is freely movable. It can be connected to moving elements such as linear slides and X-Y table by a coupling.

Mounting

The length gauges are mounted onto a flat surface by two screws. HEIDENHAIN offers the M versions for mounting in the accessory MS 100 and MS 200 gauge stands.



	Incremental			
	MT 60M	MT 60K	MT 101 M	MT 101 K
Measuring standard	DIADUR graduation on glass ceramic			
Incremental signals	~ 11 μA_{PP}			
Signal period	10 μm			
System accuracy	$\pm 0.5 \mu\text{m}$		$\pm 1 \mu\text{m}$	
Recommended measuring step	1 μm to 0.1 μm			
Measuring range	60 mm		100 mm	
Plunger actuation	Motor driven	Via coupling	Motor driven	Via coupling
Protection	IP 50			
Reference mark	One			

HEIDENHAIN-SPECTO Length Gauges

Accuracy $\pm 1 \mu\text{m}$

Thanks to their very small dimensions, the HEIDENHAIN-SPECTO length gauges are the product of choice for multipoint inspection apparatus and testing equipment.

Plunger actuation

The length gauges of the **ST 12x8** and **ST 30x8** series feature a spring-tensioned plunger that is extended at rest.

In the pneumatic length gauges **ST 12x7** and **ST 30x7** the plunger is retracted to its rest position by the integral spring. It is extended to the measuring position by application of compressed air.

Mounting

The HEIDENHAIN-SPECTO length gauges are fastened by their 8h6 standard clamping shank.



	Incremental			
	ST 1288 ST 1287	ST 1278 ST 1277	ST 3088 ST 3087	ST 3078 ST 3077
Measuring standard	DIADUR glass scale			
Incremental signals	$\sim 1 V_{PP}$	$\square \square T T L$	$\sim 1 V_{PP}$	$\square \square T T L$
Signal period	20 μm	4 μm , or 2 μm	20 μm	4 μm , or 2 μm
System accuracy	$\pm 1 \mu\text{m}$			
Recommended measuring step	1 μm to 0.2 μm			
Measuring range	12 mm		30 mm	
Plunger actuation	<i>ST 12x8/ST 30x8</i> : by measured object <i>ST 12x7/ST 30x7</i> : pneumatic			
Degree of protection	IP 64			
Reference mark	One			

Angle encoders

HEIDENHAIN angle encoders are characterized by high accuracy values in the arc second range and better. These devices are used in applications such as rotary tables, swivel heads of machine tools, dividing apparatuses, high-precision angle measuring tables, precision devices in angular metrology, antennas and telescopes.

- Line counts typically 9000 to 180000
- Accuracy from $\pm 5''$ to $\pm 0.4''$
- Measuring steps as fine as 0.000005° or $0.018''$ (incremental) or 29 bits, i.e. approx. 536 million positions per revolution (absolute)



Rotary encoders

Rotary encoders from HEIDENHAIN serve as measuring sensors for rotary motion, angular velocity and also, when used in conjunction with mechanical measuring standards such as lead screws, for linear motion. Application areas include electrical motors, machine tools, printing machines, woodworking machines, textile machines, robots and handling devices, as well as various types of measuring, testing, and inspection devices.

- Line counts of typically 50 to 5000
- Accuracy from $\pm 12''$ (depending on the line count, corresponding to $\pm 1/20$ of the grating period)
- Measuring steps to 0.001° .
Particularly with the photoelectric encoders, the high quality of the sinusoidal incremental signals permits high interpolation factors for digital speed control.



Mounting variants

In angle encoders and rotary encoders with integral bearing and **stator coupling**, the graduated disk of the encoder is connected directly to the shaft to be measured. The scanning unit is guided on the shaft via ball bearings, supported by the stator coupling. During angular acceleration of the shaft, the stator coupling must absorb only that torque resulting from friction in the bearing, thereby minimizing both static and dynamic measuring error. Moreover, the coupling mounted on the stator compensates axial motion of the measured shaft. Other benefits of the stator coupling are:

- Simple installation
- Short overall length
- High natural frequency of the coupling
- Hollow through shaft possible

Angle encoders and rotary encoders with integral bearings that are conceived for a **separate shaft coupling** are designed with a solid shaft. The recommended coupling to the measured shaft compensates radial and axial tolerances. Angle encoders for separate shaft couplings permit higher shaft speeds.

Angle encoders and rotary encoders **without integral bearing** operate without friction. The two components—the scanning head and the scale disk, drum, or tape—are adjusted to each other during assembly. The benefits are:

- Requires little space
- Large hollow-shaft diameter
- High shaft speeds
- No additional starting torque



With **incremental angle encoders and rotary encoders**, the current position is determined by starting at a datum and counting measuring steps, or by subdividing and counting signal periods. Incremental encoders from HEIDENHAIN feature reference marks to reestablish the reference point.

Incremental rotary encoders with commutation signals provide the angular shaft position value—without requiring previous traverse—with sufficient accuracy to correctly control the phases of the rotating field of a permanent-magnet three-phase motor.

Absolute angle encoders and rotary encoders require no previous traverse to provide the current position value. **Singleturn encoders** provide the current angular position value within one revolution, while **multiturn encoders** can additionally distinguish between revolutions. The position values are transmitted over an **EnDat, SSI, PROFIBUS-DP or other serial data interface**. The EnDat or PROFIBUS-DP bidirectional interfaces enable automatic configuration of the higher-level electronics and provide monitoring and diagnostic functions.

Under the designation **functional safety**, HEIDENHAIN offers encoders with purely serial data transmission as single-encoder systems for safety-related machines and systems. The two measured values are already formed independently of each other in the encoder, and are transmitted to the safe control via the EnDat interface.

Angle Encoders		Series	Page
With integral bearing and integrated stator coupling	Absolute (singleturn) Incremental	RCN RON, RPN	22
With integral bearing, for separate shaft coupling	Incremental	ROD	24
Without integral bearing	Incremental	ERP, ERA	25, 26
Modular Encoders	Incremental	ERM	28
Rotary Encoders			
With integral bearing, for mounting by stator coupling	Absolute (singleturn/multiturn) Incremental	ECN/EQN ERN	30, 32
With integral bearing, for separate shaft coupling	Absolute (singleturn/multiturn) Incremental	ROC/ROQ, RIC/RIQ ROD	34
Without integral bearing	Absolute (singleturn/multiturn) Incremental	ECI/EQI ERO	36

RCN, RON, RPN Angle Encoders

With Integral Bearing and Integrated Stator Coupling

Because of their high static and dynamic accuracy, the **RCN, RON** and **RPN** angle encoders with integral bearings and stator couplings are the preferred units for high-precision applications such as rotary tables and tilting axes. The measuring standard is a circular scale with DIADUR graduation or—with the RPN—a phase grating. For the units with stator coupling, the specified accuracy includes the error caused by the coupling. For angle encoders with separate shaft coupling, the coupling error must be added to find the system accuracy.

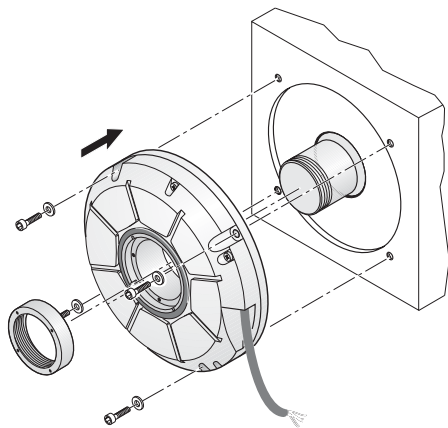

RCN/RON 200 series

- **Compact size**
- Sturdy design
- Typically used with rotary tables, tilting tables, for positioning and speed control
- Measuring steps to 0.0001°
- Versions in stainless steel (e.g. for antennas) available on request

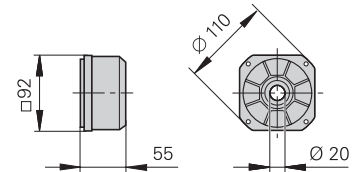

RCN/RON 700 series and RCN/RON/RPN 800

- **Large hollow shaft diameter** up to $\varnothing 100$ mm
- Measuring steps to 0.00001° with system accuracy of $\pm 2''$ and $\pm 1''$
- Typically used on rotary and angle measuring tables, indexing fixtures, measuring setups, image scanners
- Versions in stainless steel (e.g. for antennas) available on request

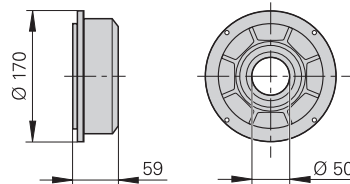

RON 785

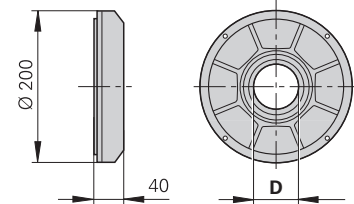



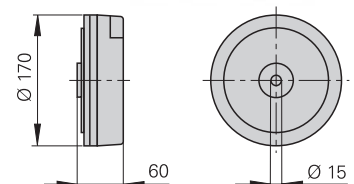

RCN 700/800 D = 60 mm or 100 mm
RON 786/886, RPN 886 D = 60 mm

RON 905

- **Very high-accuracy angle encoder**
- Measuring steps to 0.00001°
- System accuracy $\pm 0.4''$
- Used with high-accuracy measuring devices and for the inspection of measuring equipment





	Absolute			Incremental			
	RCN 226 RCN 228	RCN 223 F RCN 227 F	RCN 223 M RCN 227 M	RON 225	RON 275	RON 285	RON 287
Incremental signals	 1 V _{PP} ³⁾	–		 TTL x 2	 TTL x 5  TTL x 10	 1 V _{PP}	
Line count Signal periods/rev	16384 ³⁾	–		9000 18000	18000 90000 or 180000	18000	
Absolute position values	EnDat 2.2 ¹⁾	Fanuc 02	Mit 02-4	–			
Position values/rev	67108864 (26 bits) 268435456 (28 bits)	8388608 (23 bits) 134217728 (27 bits)		–			
System accuracy	± 5" ± 2.5"			± 5"			± 2.5"
Recommended measuring step²⁾	0.0001°			0.005°	0.001° 0.0005°	0.0001°	
Mech. perm. speed	≤ 3000 min ⁻¹			≤ 3000 min ⁻¹			

¹⁾ PROFIBUS-DP via gateway

²⁾ For position measurement

³⁾ Only for EnDat 2.2/02

	Absolute			Incremental		RPN 886
	RCN 729 RCN 829	RCN 727 F RCN 827 F	RCN 727 M RCN 827 M	RON 786 RON 785	RON 886	
Incremental signals	 1 V _{PP} ⁴⁾			–		 1 V _{PP}
Line count Signal periods/rev	32768 ⁴⁾			–		18000, 36000 ³⁾ 36000 90000 180000
Abs. position values	EnDat 2.2 ¹⁾	Fanuc 02	Mit 02-4	–		
Position values/rev	536870912 (29 bits)	134217728 (27 bits)		–		
System accuracy	RCN 72x: ± 2"; RCN 82x: ± 1"			± 2"		± 1"
Recommd. meas. step²⁾	0.0001°/0.00005°			0.0001°		0.00005° 0.00001°
Mech. perm. speed	≤ 1000 min ⁻¹			≤ 1000 min ⁻¹		

¹⁾ PROFIBUS-DP via gateway

²⁾ For position measurement

³⁾ Only RON 786

⁴⁾ Only for EnDat 2.2/02

	Incremental RON 905
Incremental signals	 11 μA _{PP}
Line count	36000
System accuracy	± 0.4"
Rec. meas. step	0.00001°
Mech. perm. speed	≤ 100 min ⁻¹

ROD Angle Encoders

With Integral Bearing, for Separate Shaft Coupling

ROD angle encoders with solid shaft for separate shaft coupling are particularly attractive for applications where high shaft speeds and large mounting tolerances are required. The precision shaft couplings allow axis motion up to ± 1 mm.

ROD angle encoders feature a DIADUR circular scale as measuring standard. For angle encoders with separate shaft coupling, the angular measuring error caused by the shaft coupling must be added to determine the system accuracy.

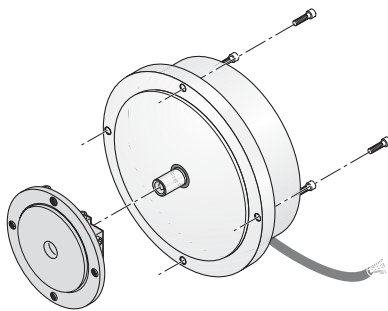

ROD 200 series

- **Compact size**
- Sturdy design
- Typically used with rotary tables, tilting tables, for positioning and synchronization monitoring
- Measuring steps to 0.0001°

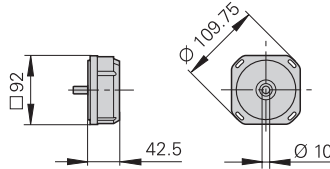

	Incremental ROD 220	ROD 270	ROD 280
Incremental signals	□ TTL x 2	□ TTL x 10	~ 1 V _{PP}
Line count Signal periods/rev	9000 18000	18000 180000	18000
System accuracy¹⁾	± 5"		
Rec. meas. step²⁾	0.005°	0.0005°	0.0001°
Mech. perm. speed	≤ 10000 min ⁻¹		

¹⁾ Without shaft coupling

²⁾ For position measurement

ROD 780 and ROD 880

- **High accuracy**
± 2" (ROD 780) or
± 1" (ROD 880)
- Measuring steps to 0.00005°
- Ideal for angle measurement on high-precision rotary tables, dividing apparatuses or measuring machines

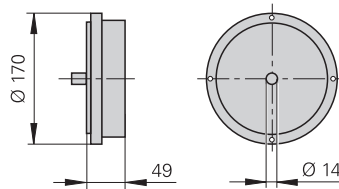

	Incremental ROD 780	ROD 880
Incremental signals	~ 1 V _{PP}	
Line count	18000, 36000	36000
System accuracy¹⁾	± 2"	± 1"
Rec. meas. step²⁾	0.0001°	0.00005°
Mech. perm. speed	≤ 1000 min ⁻¹	

¹⁾ Without shaft coupling

²⁾ For position measurement

ERP Angle Encoders

Without Integral Bearing

The HEIDENHAIN **ERP** angle encoders without integral bearing are intended for integration in machine elements or components. They operate without friction and permit high accuracy. This makes them particularly attractive for high-precision angle measuring tables and precision devices in angular metrology. The **ERP 4080** and **ERP 8080** angle encoders are designed for applications in the clean room.

A circular scale with phase grating serves as the basis for the high accuracy of the ERP encoders. The attainable system accuracy depends on the eccentricity of the graduation to the drive shaft bearing, as well as the radial runout and wobble of the bearing.

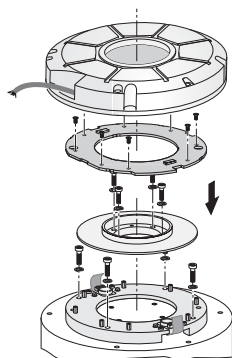

Mounting the ERP 880

ERP 880

- **Very high accuracy**
- Very fine grating period
- Low error within one signal period thanks to the interferential scanning principle

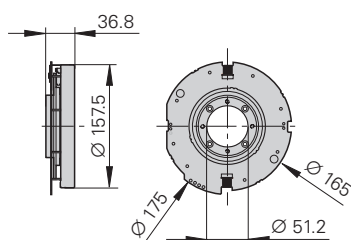

ERP 880 with housing

	Incremental ERP 880
Incremental signals	$\sim 1 V_{PP}$
Line count	90000
Signal periods	180000
System accuracy¹⁾	$\pm 1''$
Recommd. meas. step²⁾	0.00001°
Mech. perm. speed	$\leq 1000 \text{ min}^{-1}$

¹⁾ Before installation. Additional error is caused by imprecise mounting and the bearing.

²⁾ For position measurement

ERP 4080 and ERP 8080

- Very high accuracy
- Very compact dimensions
- Low error within one signal period thanks to the interferential scanning principle

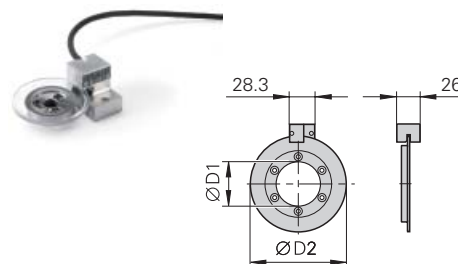

	Incremental ERP 4080	ERP 8080
Incremental signals	$\sim 1 V_{PP}$	
Line count	65536	180000
Signal periods	131072	360000
System accuracy¹⁾	$\pm 5''$	$\pm 2''$
Rec. meas. step²⁾	0.00001°	0.000005°
Diameter D1/D2	8 mm/44 mm	50 mm/108 mm
Mech. perm. speed	$\leq 300 \text{ min}^{-1}$	$\leq 100 \text{ min}^{-1}$

¹⁾ Before installation. Additional error is caused by imprecise mounting and the bearing.

²⁾ For position measurement

ERA Angle Encoders

Without Integral Bearing

The HEIDENHAIN **ERA** angle encoders without integral bearing are intended for integration in machine elements or components. They are designed to meet the following requirements:

- Large hollow shaft diameters (up to 10 m with scale tape)
- High shaft speeds up to 10000 min⁻¹
- No additional starting torque from shaft seals

The attainable system accuracy depends on the eccentricity of the graduation to the drive shaft bearing, as well as the radial runout and wobble of the bearing.

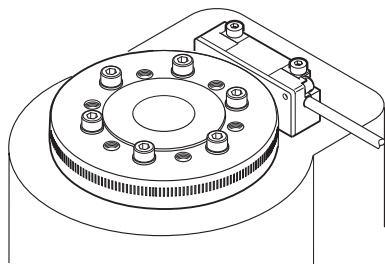

ERA 4000

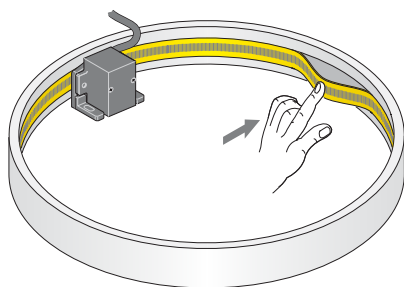

ERA 780C

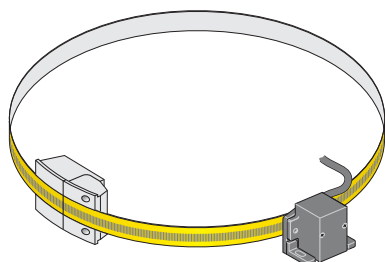

ERA 880C

ERA 4000 series

- **High shaft speeds** up to 10000 min⁻¹
- Sturdy design with steel scale drum with METALLUR graduation
- Axial motion of measured shaft permissible up to ± 0.5 mm
- Typical application on fast spindles and ball screws
- The ERA 4480C is available for larger diameters or in versions with protective cover
- Various **drum versions**
 - ERA 4x80C:** solid version with centering collar for high speeds
 - ERA 4x81C:** with T-section for 3-point centering with low weight and low moment of inertia
 - ERA 4282C:** solid version with 3-point centering for high accuracy requirements

Incremental signals

Inside diameter D1

Outside diameter D2

Line count/ System accuracy ²⁾	ERA 4280C ERA 4480C ERA 4880C
--	-------------------------------------

Mech. perm. speed



ERA 700 and ERA 800 series

- **For very large diameters** up to 10 m
- AURODUR steel scale tape
- High accuracy even at the junction of the scale-tape ends

ERA 700 series

Scale tape is placed in a slot on the inside circumference of the machine element

- **ERA 780C:** full-circle version
- **ERA 781C:** circle-segment version



ERA 781C

ERA 800 series

Scale tape is fastened on the outside circumference of the machine element

- **ERA 880C:** full-circle version
- **ERA 881C:** segment, scale tape secured with tensioning elements
- **ERA 882C:** segment, scale tape secured without tensioning elements



ERA 880C

Incremental ERA 4280 C ¹⁾ Signal period 20 μm ERA 4480 C ¹⁾ Signal period 40 μm ERA 4880 C Signal period 80 μm									
 1 V _{PP}									
40 mm	70 mm	80 mm	120 mm	150 mm	180 mm	270 mm	425 mm	512 mm	
76.75 mm	104.63 mm	127.64 mm	178.55 mm	208.89 mm	254.93 mm	331.31 mm	484.07 mm	560.46 mm	
12000/± 6.1" 6000/± 7.2" 3000/± 9.4"	16384/± 4.5" 8192/± 5.3" 4096/± 6.9"	20000/± 3.7" 10000/± 4.3" 5000/± 5.6"	28000/± 3.0" 14000/± 3.5" 7000/± 4.4"	32768/± 2.9" 16384/± 3.3" 8192/± 4.1"	40000/± 2.9" 20000/± 3.2" 10000/± 3.8"	52000/± 2.8" 26000/± 3.0" 13000/± 3.5"	– 38000/± 2.4" –	– 44000/± 2.3" –	
≤ 10000 min ⁻¹	≤ 8500 min ⁻¹	≤ 6250 min ⁻¹	≤ 4500 min ⁻¹	≤ 4250 min ⁻¹	≤ 3250 min ⁻¹	≤ 2500 min ⁻¹	≤ 1800 min ⁻¹	≤ 1500 min ⁻¹	

¹⁾ For other drum versions, please refer to our catalog *Angle Encoders without Integral Bearings*

²⁾ Before installation. Additional error is caused by imprecise mounting and the bearing.

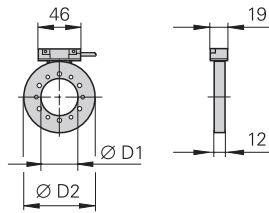

ERA 4000

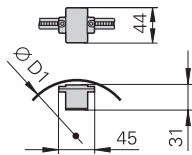

ERA 780

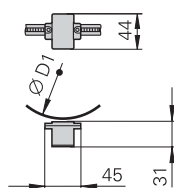

ERA 880

	Incremental				
	ERA 780 C			ERA 880 C	
Incremental signal	 1 V _{PP} ; signal period 40 μm (on circumference)				
Line count	36000	45000	90000	36000	45000
System accuracy ¹⁾	± 3,5"	± 3,4"	± 3,2"	± 3,5"	± 3,4"
Diameter D1	458.62 mm	573.20 mm	1146.10 mm	458.04 mm	572.63 mm
Mech. perm. speed	≤ 500 min ⁻¹			≤ 100 min ⁻¹	

¹⁾ Before installation. Additional error is caused by imprecise mounting and the bearing.

ERM Modular Encoders Without Integral Bearing

The **ERM** modular encoders from HEIDENHAIN consist of a magnetized scale drum and a scanning unit with magnetoresistive sensor. Their MAGNODUR measuring standard and the magnetoresistive scanning principle make them particularly tolerant to contamination.

Typical applications include machines and equipment with **large hollow shaft diameters** in environments with large amounts of airborne particles and liquids, for example on the spindles of lathes or milling machines, for reduced accuracy requirements.

ERM 200
Scale drum

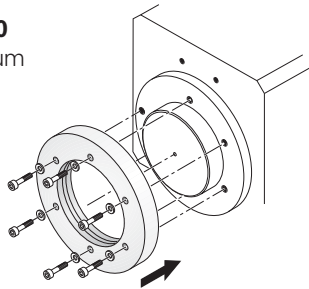

ERM 2404
Scale drum

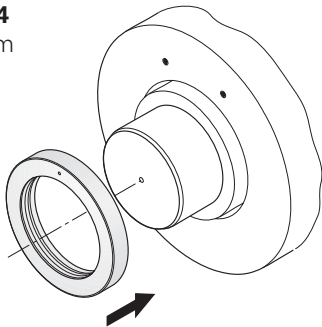

ERM 2405
Scale drum

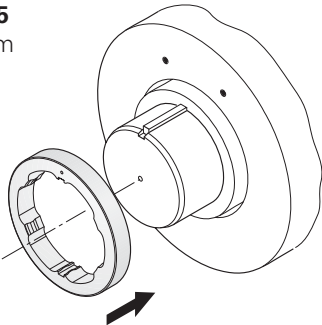

ERM
Scanning head

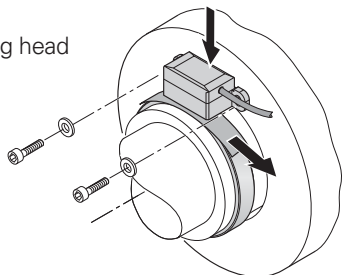

ERM 200

- For large shaft diameters up to 410 mm
- Drum fastening with axial screws

ERM 2410

- Consists of ERM 2410 scanning head and the ERM 200 scale drum
- Incremental measuring method with distance-coded reference marks
- Integrated counting function for **absolute position-value output**
- Absolute position value after traverse of two reference marks

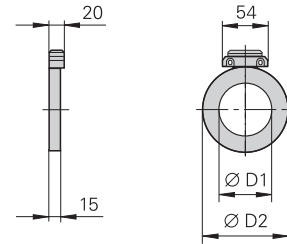

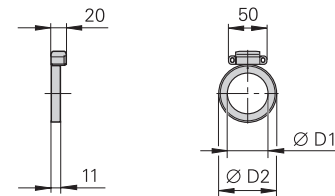

ERM 2400 series

- Especially compact dimensions for limited installation space
- High mechanically permissible shaft speeds and therefore particularly well suited for spindles
- **ERM 2484**: Drum fastening by axial clamping
- **ERM 2485**: Drum fastening by axial clamping and feather key as anti-rotation element



ERM 2484

	Incremental									
	ERM 220 ERM 280 ERM 2410									
Incremental signals	ERM 220:  TTL ERM 280:  1 V _{PP} ERM 2410: -									
Absolute position values¹⁾	ERM 2410: EnDat 2.2									
Inside diameter D1	40 mm	70 mm	80 mm	120 mm	130 mm	180 mm	220 mm	295 mm	410 mm	
Outside diameter D2	75.44 mm	113.16 mm	128.75 mm	150.88 mm	176.03 mm	257.50 mm	2570.50 mm	326.90 mm	452.64 mm	
Line count	600	900	1024	1200	1400	2048	2048	2600	3600	
Shaft speed	≤ 19000 min ⁻¹	≤ 14500 min ⁻¹	≤ 13000 min ⁻¹	≤ 10500 min ⁻¹	≤ 9000 min ⁻¹	≤ 6000 min ⁻¹	≤ 6000 min ⁻¹	≤ 4500 min ⁻¹	≤ 3000 min ⁻¹	
Operating temp.	-10 °C to 100 °C									

¹⁾ Through integrated counting function after traverse of two reference marks

	Incremental			
	ERM 2484		ERM 2485	
Incremental signals	 1 V _{PP}			
Inside diameter D1	40 mm	55 mm	40 mm	55 mm
Outside diameter D2	64.37 mm	75.44 mm	64.37 mm	75.44 mm
Line count	512	600	512	600
Shaft speed	≤ 42000 min ⁻¹	≤ 36000 min ⁻¹	≤ 33000 min ⁻¹	≤ 27000 min ⁻¹
Operating temperature	-10 °C to 100 °C			

ECN, EQN, ERN Rotary Encoders

With Integral Bearing and Mounted Stator Coupling Protection IP 64

HEIDENHAIN **ECN, EQN** and **ERN** rotary encoders with integral bearings and stator-mounted couplings operate by photo-electric scanning. They are characterized by their simple mounting and short overall length. Possible applications range from simple measuring tasks to position and speed control on servo drives. The hollow shaft of these encoders is slid directly onto and fastened to the shaft to be measured. During angular acceleration of the shaft, the stator coupling must absorb only that torque caused by friction in the bearing. Rotary encoders with stator coupling therefore provide excellent dynamic performance and a high natural frequency.

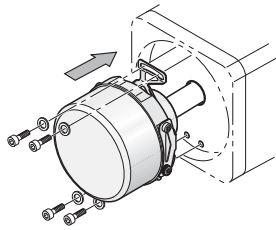

ECN/EQN/ERN 1000
ECN/EQN/ERN 400

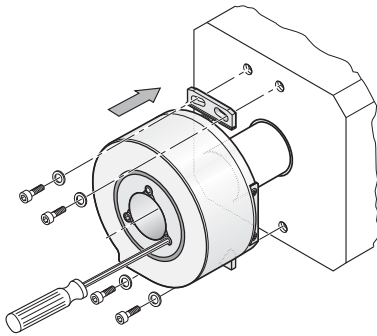

ECN/ERN 100

ECN, EQN, ERN 1000 series

- **Miniaturized version**
- Blind hollow shaft with 6 mm inside diameter
- Housing outside diameter 35 mm
- Natural frequency of the encoder stator coupling: ≥ 1800 Hz
- Mechanically permissible speed: $\leq 12000 \text{ min}^{-1}$

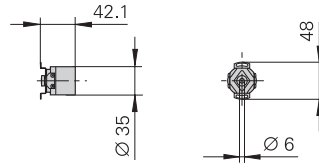

Incremental signals

Line count

Absolute position values

Position values per rev

Distinguishable revolutions

Power supply

Operating temperature

ECN, EQN, ERN 400 series

- **Compact size**
- Blind hollow shaft or hollow through shaft with 8 mm or 12 mm inside diameter
- Housing outside diameter 58 mm
- Degree of protection:
IP 67 at housing (IP 66 with hollow through shaft)
IP 64 at shaft inlet (IP 66 upon request)
- Natural frequency of the encoder stator coupling: ≥ 1400 Hz (cable version)
- Mechanically permissible speed: $\leq 12000 \text{ min}^{-1}$

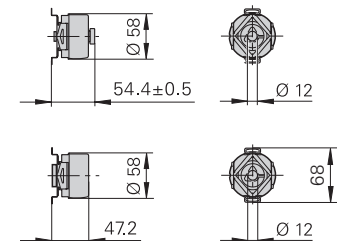

ECN/ERN 100 series

- **For large shaft diameters**
- Hollow through shaft with inside diameters D: D: 20 mm, 25 mm, 38 mm, 50 mm
- Housing outside diameter 87 mm
- Natural frequency of the encoder stator coupling: ≥ 1000 Hz
- Mechanically permissible speed:
 $\leq 6000 \text{ min}^{-1}$ (D ≤ 30 mm)
 $\leq 4000 \text{ min}^{-1}$ (D > 30 mm)

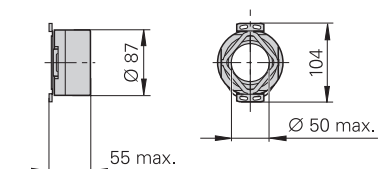

Absolute				Incremental				
ECN 1013	EQN 1025	ECN 1023 ²⁾	EQN 1035 ²⁾	ERN 1020	ERN 1030	ERN 1070	ERN 1080	ERN 1085
~ 1 V _{PP}		-					~ 1 V _{PP}	~ 1 V _{PP}
512		-		100 to 3600		1000 to 3600	100 to 3600	512/2048
EnDat 2.2 (PROFIBUS-DP via Gateway)				-				Z1 track ¹⁾
8192 (13 bits)		8388608 (23 bits)		-				
-	4096 (12 bits)	-	4096 (12 bits)	-				
3.6 to 14 V				5 V	10 to 30 V	5 V		
≤ 100 °C				≤ 100 °C	≤ 70 °C		≤ 100 °C	

¹⁾ Sine and cosine signal per revolution ²⁾ **Functional safety** upon request

	Absolute				Incremental			
	ECN 413	EQN 425	ECN 425 ²⁾	EQN 437 ²⁾	ERN 420	ERN 430	ERN 460	ERN 480
Incremental signals	~ 1 V _{PP}		-					~ 1 V _{PP}
Line count	512 or 2048		-		250 to 5000			1000 to 5000
Abs. position values	EnDat 2.2 ¹⁾ or SSI		EnDat 2.2 ¹⁾		-			
Position values per rev	8192 (13 bits)		33554432 (25 bits)		-			
Distinguishable revolutions	-	4096 (12 bits)	-	4096 (12 bits)	-			
Power supply	EnDat: 3.6 to 14 V SSI: 5 V or 10 to 30 V		3.6 to 14 V		5 V	10 to 30 V		5 V
Operating temperature	5 V: ≤ 100 °C 10 to 30 V: ≤ 85 °C		≤ 100 °C		≤ 100 °C		≤ 70 °C	≤ 100 °C

¹⁾ Includes EnDat 2.1 command set; PROFIBUS-DP via Gateway ²⁾ **Functional safety** upon request

	Absolute		Incremental		
	ECN 113	ECN 125	ERN 120	ERN 130	ERN 180
Incremental signals	~ 1 V _{PP}	-			~ 1 V _{PP}
Line count	2048	-	1000 to 5000		
Absolute position values	EnDat 2.2 ¹⁾ or SSI	EnDat 2.2 ¹⁾	-		
Position values per rev	8192 (13 bits)	33554432 (25 bits)	-		
Power supply	5 V ²⁾	3.6 to 5.25 V	5 V	10 to 30 V	5 V
Operating temperature	≤ 100 °C		≤ 100 °C	≤ 100 °C (U _P ≤ 15 V) ≤ 85 °C (U _P ≤ 30 V)	≤ 100 °C

¹⁾ Includes EnDat 2.1 command set; PROFIBUS-DP via gateway ²⁾ 10 to 30 V via connecting cable with voltage converter (only SSI)

ECN, EQN, ERN Rotary Encoders

With Integral Bearing and Mounted Stator Coupling Protection IP 40

The **ECN, EQN** and **ERN** rotary encoders from HEIDENHAIN with IP 40 degree of protection are specially designed for integration in motors. Bearings and mounted stator coupling are integrated. Absolute rotary encoders and versions with commutation tracks are available for synchronous motors. The taper shaft or the blind hollow shaft is fastened directly to the shaft to be measured. This ensures an extremely stiff coupling that permits exceptionally high dynamic performance of the drive. The stator coupling is designed to be fastened in a location bore and permits fast, simple mounting while enabling a mechanical fine adjustment of the commutation.

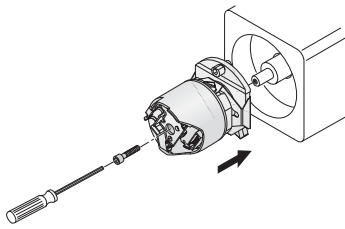

ERN/ECN/EQN 1100

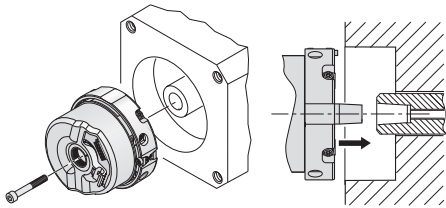

ERN/ECN/EQN 1300

ECN, EQN, ERN 1100 series

- **Miniaturized version**
- Blind hollow shaft $\varnothing 6$ mm
- Housing outside diameter 35 mm
- Stator coupling for location holes with inside diameter **45 mm**
- Natural frequency of the encoder stator coupling: ≥ 1500 Hz
- Mech. permissible speed 12000 min^{-1}

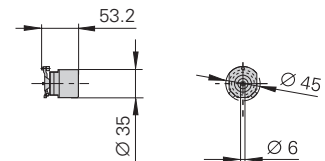

ECN, EQN, ERN 1300 series

- **Compact dimensions**
- 1:10 taper shaft with 9.25 mm functional diameter for extremely stiff connection
- Housing outside diameter 56 mm. The stator coupling is suited for location holes with 65 mm inside diameter
- Natural frequency of the encoder stator coupling: ≥ 1800 Hz
- Mech. perm. speed
 - ERN/ECN: 15000 min^{-1}
 - EQN: 12000 min^{-1}
- IP 40 protection when mounted

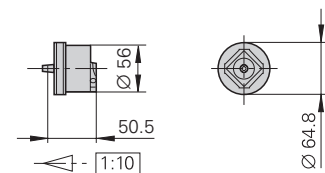

	Absolute				Incremental		
	ECN 1113	EQN 1125	ECN 1123 ³⁾	EQN 1135 ³⁾	ERN 1120	ERN 1180	ERN 1185
Incremental signals	~ 1 V _{PP}		-		□□TTL	~ 1 V _{PP}	
Line count	512		-		250, 512, 1024, 2048, 3600		512 or 2048
Commutation signals	-		-		-		Z1 track ²⁾
Absolute position values	EnDat 2.2 ¹⁾				-		
Position values per rev	8192 (13 bits)		8388608 (23 bits)		-		
Distinguishable revolutions	-	4096 (12 bits)	-	4096 (12 bits)	-		
Power supply	3.6 to 14 V				5 V		
Operating temperature	≤115 °C				≤100 °C		≤115 °C

¹⁾ Includes EnDat 2.1 command set; PROFIBUS-DP via Gateway

²⁾ One sine and one cosine signal with one period per revolution of the encoder shaft

³⁾ **Functional safety** upon request

	Absolute				Incremental			
	ECN 1313	EQN 1325	ECN 1325 ⁴⁾	EQN 1337 ⁴⁾	ERN 1321	ERN 1326	ERN 1381	ERN 1387
Incremental signals	~ 1 V _{PP}		-		□□TTL		~ 1 V _{PP}	
Line count	512 or 2048		-		1024 2048 4096	512 2048 4096	2048	
Commutation signals	-		-		-	Block commutation ²⁾	-	Z1 track ³⁾
Absolute position values	EnDat 2.2 ¹⁾		EnDat 2.2 ¹⁾		-			
Position values per rev	8192 (13 bits)		33554432 (25 bits)		-			
Distinguishable revolutions	-	4096 (12 bits)	-	4096 (12 bits)	-			
Power supply	3.6 to 14 V				5 V			
Operating temperature	≤ 115 °C		≤ 115 °C		≤ 120 °C; 4096 lines: ≤ 100 °C			

¹⁾ Includes EnDat 2.1 command set; PROFIBUS-DP via Gateway

²⁾ Three block commutation tracks with 90° or 120° mechanical phase shift

³⁾ One sine and one cosine signal with one period per revolution of the encoder shaft

⁴⁾ **Functional safety** upon request

ROC, ROQ, ROD and RIC, RIQ Rotary Encoders

With Integral Bearing, for Separate Shaft Coupling

The optical encoders **ROC, ROQ** and **ROD**, as well as the inductive **RIC** and **RIQ** from HEIDENHAIN have integrated bearings and are sealed. They provide IP 64 to IP 67 protection, depending on the version. They are robust and compact.

These encoders are coupled by the rotor to the measured shaft through a separate coupling that compensates axial motion and misalignment between the encoder shaft and measured shaft.

Some rotary encoders are suitable in a special version for potentially explosive atmospheres in accordance with Directive 94/9/EG, (**ATEX**).

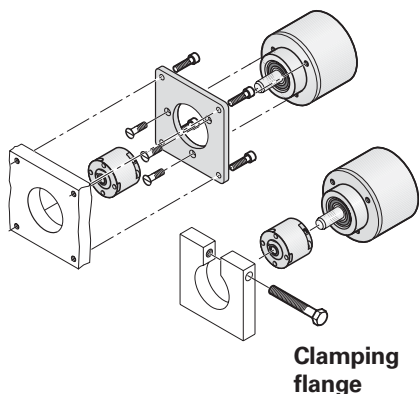
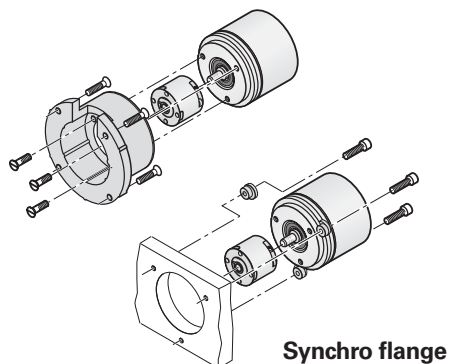

ROD 1000 series

- **Miniaturized dimensions** for installation in small devices or in limited installation space
- Mounting by synchro flange
- Shaft diameter 4 mm

Series 1000

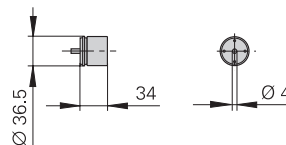

ROC, ROQ, ROD 400 series

- **Industrial standard** for dimensions and output signals
- Degree of protection IP 67 at housing IP 64 at shaft end (IP 66 available on request)
- Mounting by synchro flange or clamping flange
- Shaft diameters 6 mm with synchro flange 10 mm with clamping flange
- Preferred types with fast delivery (see *Rotary Encoders* brochure or ask HEIDENHAIN)

ROD 400 series with synchro flange

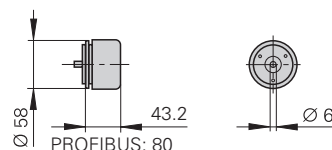

RIC/RIQ 400 series

- Inductive scanning principle
- For reduced accuracy requirements up to $\pm 480''$
- Mechanical design same as ROC/ROQ 400

	Absolute Singletum				
	RIC 418	ROC 413		ROC 425	
Synchro flange	RIC 418	ROC 413		ROC 425	
Clamping flange	RIC 418	ROC 413		ROC 425	
Incremental signals	$\sim 1 V_{PP}$			-	
Line count/ Signal periods	16	512	-		
Absolute position values	EnDat 2.1	EnDat 2.2 ²⁾	SSI 39r1	PROFIBUS-DP V0	EnDat 2.2 ²⁾
Positions per rev	262 144 (18 bits)	8 192 (13 bits)			33 554 432 (25 bits)
Distinguishable revolutions	-				
Power supply	5 V	3.6 to 14 V	5 V or 10 to 30 V	9 to 36 V	3.6 to 14 V
Operating temperature	$\leq 100\text{ }^{\circ}\text{C}$		$\leq 100\text{ }^{\circ}\text{C}$	$\leq 70\text{ }^{\circ}\text{C}$	$\leq 100\text{ }^{\circ}\text{C}$

¹⁾ ATEX version available

²⁾ Includes EnDat 2.1 command set; PROFIBUS-DP via Gateway

	Absolute				Incremental			
	Singletum		Multitum					
	ROC 1013	ROC 1023 ¹⁾	ROQ 1025	ROQ 1035 ¹⁾	ROD 1020	ROD 1030	ROD 1070	ROD 1080
Incremental signals	~ 1 V _{PP}	–	~ 1 V _{PP}	–	□ TTL	□ HTL	□ TTL ²⁾	~ 1 V _{PP}
Line count	512	–	512	–	100 to 3600		1000/2500 3600	100 to 3600
Absolute position values	EnDat 2.2				–			
Position values per rev	8192	8388608 (23 bits)	8192 (13 bits)	8388608 (23 bits)	–			
Distinguishable revolutions	–		4096 (12 bits)		–			
Power supply	3.6 to 14 V				5 V	10 to 30 V	5 V	5 V
Operating temperature	≤ 100 °C				≤ 100 °C	≤ 70 °C		≤ 100 °C

¹⁾ Functional safety upon request ²⁾ 5/10-fold integrated interpolation

ROD 400 series with clamping flange

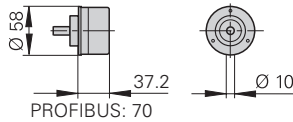

PROFIBUS DP



Multitum					Incremental		
RIQ 430	ROQ 425		ROQ 437	ROD 426	ROD 466	ROD 436	ROD 486
RIQ 430	ROQ 425		ROQ 437	ROD 420¹⁾	–	ROD 430	ROD 480
–	~ 1 V _{PP}		–	□ TTL		□ HTL	~ 1 V _{PP}
–	512		–	50 to 5000 <i>ROD 426/466: up to 10000³⁾</i>			1000 to 5000
EnDat 2.1	EnDat 2.2 ²⁾	SSI 41r1	PROFIBUS-DP V0	EnDat 2.2 ²⁾	–		
262144 (18 bits)	8192 (13 bits)		33554432 (25 bits)	–			
4096 (12 bits)				–			
5 V	3.6 to 14 V	5 V or 10 to 30 V	9 to 36 V	3.6 to 14 V	5 V	10 to 30 V	5 V
≤ 100 °C		≤ 100 °C	≤ 70 °C	≤ 100 °C	≤ 100 °C	≤ 70 °C	≤ 100 °C

³⁾ Signal periods over 5000 are generated through signal doubling in the encoder

ECI, EQI, ERO Rotary Encoders

Without Integral Bearing

The inductive rotary encoders **ECI/EQI** are mechanically compatible with the photoelectric encoders ExN: the shaft is fastened with a central screw. The stator of the encoder is screw fastened in a location hole.

The photoelectric **ERO** modular rotary encoders from HEIDENHAIN consist of a graduated disk with hub and a scanning unit. They are particularly well suited for **limited installation space** or for applications for which there must be **no friction**.

The correct installation of the rotary encoders without integral bearing can be inspected with the HEIDENHAIN measuring and testing devices IK 215 or PWM9.

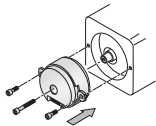

ECI/EQI 1100

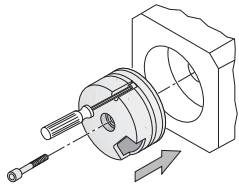

ECI/EQI 1300

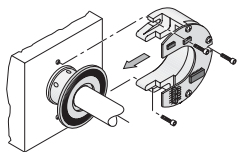

ERO 1200

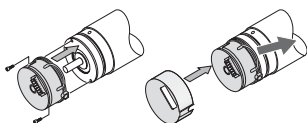

ERO 1400

ECI/EQI 1100 series

- **Mating compatible with the ECN/EQN 1100**
- Simple mounting without adjustment
- Blind hollow shaft \varnothing 6 mm



ECI/EQI 1300 series

- **Mating compatible with the ECN/EQN 1300**
- Taper shaft or blind hollow shaft



ERO 1200 series

- **Compact design**
- For shaft diameters up to 12 mm



ERO 1400 series

- **Miniaturized modular rotary encoder** for measured shafts up to \varnothing 8 mm
- Special integral mounting aid
- With cover cap



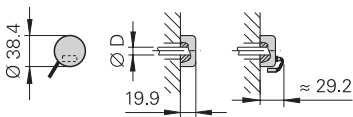
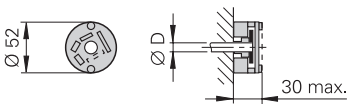
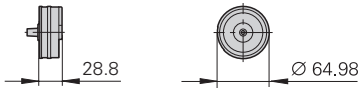
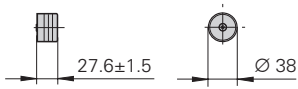

	Absolute			
	ECI 1118	EQI 1130	ECI 1319	EQI 1331
Incremental signals	~ 1 V _{PP} ; 16 lines		~ 1 V _{PP} ; 32 lines	
Absolute position values	EnDat 2.1			
Position values per rev	262 144 (18 bits)		524 288 (19 bits)	
Distinguishable revolutions	–	4 096 (12 bits)	–	4 096 (12 bits)
Mech. permissible speed	≤ 15 000 min ⁻¹	≤ 12 000 min ⁻¹	≤ 15 000 min ⁻¹	≤ 12 000 min ⁻¹
Shaft	Blind hollow shaft		Taper shaft or blind hollow shaft	

	Incremental	
	ERO 1225	ERO 1285
Incremental signals	□TTL	~ 1 V _{PP}
Line count	1 024 2 048	
Mech. permissible speed	≤ 25 000 min ⁻¹	
Shaft diameter D	Ø 10, 12 mm	

	Incremental		
	ERO 1420	ERO 1470	ERO 1480
Incremental signals	□TTL	□TTL ¹⁾	~ 1 V _{PP}
Line count	512 1 000 1 024	1 000 1 500	512 1 000 1 024
Mech. permissible speed	≤ 30 000 min ⁻¹		
Shaft diameter D	Ø 4, 6, 8 mm		

¹⁾ Integrated 5/10/20/25-fold interpolation

Contouring controls for milling, drilling, boring machines and machining centers

TNC contouring controls from HEIDENHAIN for milling, drilling, boring machines and machining centers cover an entire range of applications: From the simple, compact TNC 320 3-axis control to the iTNC 530 (up to 13 axes plus spindle)—there's a HEIDENHAIN TNC control for nearly every application.

The HEIDENHAIN TNC controls are versatile: They feature both **shop-floor programming**, and **offline programming**, and are therefore ideal for **automated production**. They handle simple milling tasks just as reliably as the iTNC 530, for example, can perform **high speed cutting**—with especially jerk-free path control—or **5-axis machining** with swivel head and rotary table.

TNC part programs have long lives because they are **upwardly compatible**. Programs from older TNCs can also run on the new models. When moving up to a more advanced TNC, the user merely builds on what he already knows.

The controls from HEIDENHAIN can be used for almost every task. It offers the right programming mode for any job.

Programming at the machine

Its workshop-oriented design enables the machinist to program directly at the machine.

Thanks to its **conversational programming**, the user need not learn G codes or special programming languages. The control “speaks” with him with easily understandable questions and prompts. Ease of use is also promoted by clear, **unambiguous key symbols** and names. Each key has only one function.

The alternative **smarT.NC** operating mode makes programming even easier. Easily understandable program entry in fillable forms, default setting for globally valid values, numerous selections and straightforward graphic support ensure fast and user-friendly operation.

The **easy-to-read screen** displays plain-language information, dialog guidance, programming steps, graphics, and a soft-key row. All texts are available in **numerous languages**.



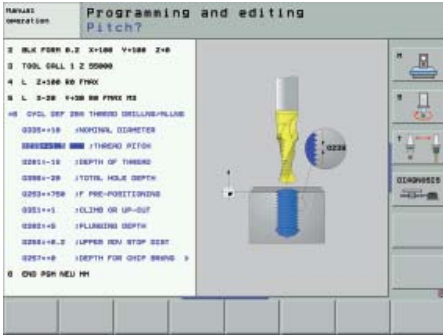

Conversational programming



Key symbols



smarT.NC:
Programming with fillable forms

Frequently recurring machining sequences are saved as **fixed cycles**. **Graphic illustrations** simplify programming and provide valuable aid for verifying the program during test runs.

And if you are used to **G-code programming**, then HEIDENHAIN controls are still the right controls for you.

Positioning with Manual Data Input

You can start working with the HEIDENHAIN controls even before writing a complete part program. Simply machine a part step by step—switching as you want between manual operation and automatic positioning.

Creating programs offline

The HEIDENHAIN controls can be programmed remotely just as well—for example on a CAD/CAM system or at a HEIDENHAIN programming station. Their **Ethernet interface** guarantees very short transfer times, even of long programs.

You can open **DXF files** created in a CAD system directly on the iTNC 530 to extract contours and machining positions. Not only does this save time otherwise spent on programming and testing, but you can also be sure that the transferred data are exactly according to the designer's specifications.

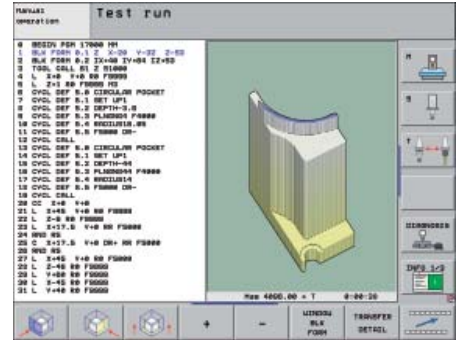

Test Run



Offline programming

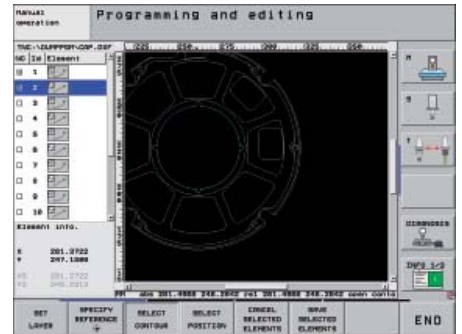

DXF data processing

HEIDENHAIN Contouring Controls

For milling, drilling, boring machines and machining centers

Up to 13 axes plus spindle

Series

iTNC 530

Page

41

For simple milling, drilling and boring machines

Up to five axes plus spindle

TNC 620

44

Up to four axes plus spindle

TNC 320

44

Accessories

Electronic handwheels

HR

46

Programming stations

iTNC

46

TNC 320/TNC 620

Digital drive control

High surface definition, high contouring accuracy of the finished workpiece, and short machining times—these requirements can be met only with digital control techniques. Here HEIDENHAIN offers NC products with integrated **digital drive control**.

Either compact or modular inverters are available, depending on the type of machine. The **compact inverters** contain the power stage for up to 2 axes, 3 axes, or 4 axes plus spindle with spindle power ratings up to 15 kW. With **modular inverters**, various power modules are available for axes and spindles, and power supply units with 22 kW to 80 kW. The modular inverters are suitable for machines with up to 13 axes and a spindle with maximum power of up to 40 kW.

Feed motors of 1.5 Nm to 62.5 Nm and **spindle motors** of 5.5 kW to 40 kW are available for connection to HEIDENHAIN inverters.



iTNC 530
with modular inverter and
motors

iTNC 530 Contouring Control

For Milling, Drilling, Boring Machines and Machining Centers

The iTNC 530 from HEIDENHAIN is a versatile, workshop-oriented contouring control for milling, drilling and boring machines as well as machining centers. The iTNC 530 is universal, and its broad and complex range of applications proves it.

- Universal milling machines
- High speed milling
- Five-axis machining with swivel head and rotary table
- Five-axis machining on very large machines
- Boring mills
- Machining centers and automated machining

The iTNC 530 controls up to 13 axes and a spindle. The block processing time is 0.5 ms. A hard disk serves as program memory medium.

It features an integrated digital drive control with integrated inverter, which enables it to produce a highly accurate workpiece contour while machining at high velocity.

The iTNC 530 hardware option with two processors additionally features the Windows XP operating system as a user interface, enabling the use of standard Windows applications.

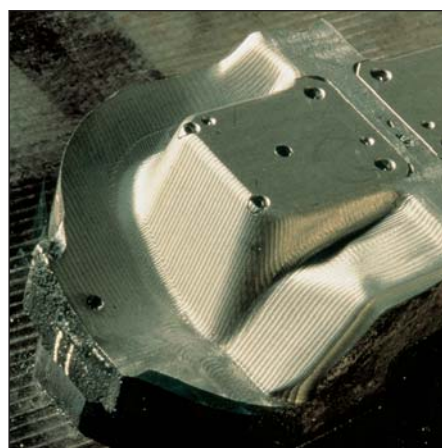

iTNC 530 Contouring Control

Features and Specifications

High speed milling with the iTNC 530

The iTNC 530's special drive strategies enable very high machining speeds with the greatest possible contouring accuracy.

High contour accuracy at high feed rates

The control loop of the iTNC 530 is fast and it "looks ahead." Like all TNC contouring controls from HEIDENHAIN, the iTNC 530 features velocity feedforward control, which means that it can machine with a very small following error of only a few micrometers. The integrated motor control has further improved contour accuracy, both through digital control technology and the additional acceleration feedforward capability. This also improves the machine's dynamic performance, with following error approaching zero. The benefit to you is dramatically improved geometrical accuracy, particularly when milling small radii at high speeds.

High speed spindle speeds

High surface-cutting speeds require accordingly high spindle speeds. The iTNC 530 can digitally control rotational speeds up to 40000 rpm.

Machining 2-D contours or 3-D surfaces at high feed rates

The iTNC 530 provides the following important features for machining contours:

- The iTNC's ability to limit and reduce jerk ensures smoother acceleration and optimum motion control—both during workpiece approach, on the contour, and at corners.

- When running long programs from the hard disk, the iTNC has a short block processing time of only 0.5 ms. This means that the iTNC can even mill contours made of 0.1 mm line segments at feed rates as high as 12 meters per minute.
- The iTNC looks ahead up to 1024 blocks into the part program to ensure a steady traversing speed even over a large number of very short contour elements.
- The iTNC can automatically smoothen discontinuous contour transitions—and you define the desired tolerance range. The iTNC mills smooth surfaces without risking dimensional tolerances.

Dynamic Collision Monitoring Option (DCM)

Since axis movements in 5-axis machining operations are very difficult to predict, and the traverse speeds of NC axes continue to increase, collision monitoring is a useful function for relieving the machine operator and avoiding damage to the machine.

The iTNC 530 cyclically monitors the working space of the machine for possible collisions with machine components and fixtures. The machine manufacturer defines these machine components within the kinematics description as collision objects. The user enters the position of the fixtures in the working space. The control issues an error message in time before a collision can occur. The machine operator can then retract the axes.

AFC Adaptive Feed Rate Control (Option)

Adaptive Feed Control (AFC) is the completely integrated, adaptive feed rate control of the iTNC 530. It controls the iTNC's contouring feed rate automatically—depending on the respective spindle power consumption and other process data, but independently from the NC program.

Benefits of adaptive feed control:

- **Optimizing the machining time**
The iTNC controls the feed rate so that the previously "learned" maximum spindle power is complied with during the entire machining time. This significantly reduces the total machining time, particularly in machining zones with little stock removal (e.g. with fluctuations in allowances)
- **Tool monitoring**
AFC permanently compares the spindle power with the feed rate. As a tool becomes blunt, the spindle power increases. As a result, the iTNC reduces the feed rate, or reacts with an error message and switches the spindle off.
- **Protection of the machine mechanics**
Reducing the feed rate down to the reference value whenever the learned maximum permissible spindle power is exceeded also reduces the strain and wear on the machine. It effectively protects the spindle from overload.

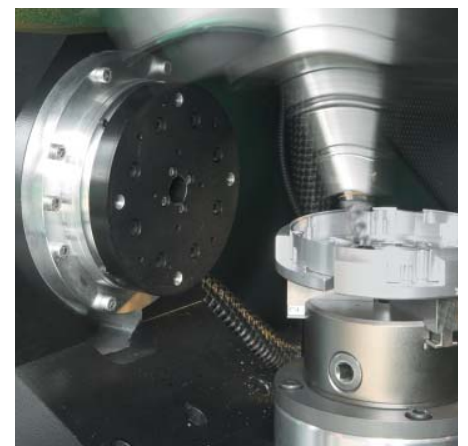
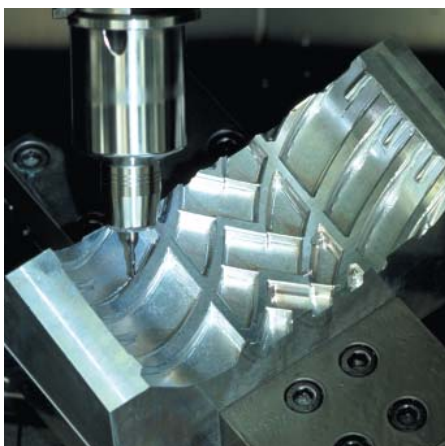

	iTNC 530
Axes	Up to 13 and spindle or 12 axes and 2 spindles
Interpolation	<ul style="list-style-type: none"> • Linear in max. 5 axes (with Tool Center Point Management) • Circular in max. 3 axes with tilted working plane • Spline interpolation in max. 5 axes • Helix • Cylinder surface¹⁾ • Rigid tapping¹⁾
Programming	HEIDENHAIN conversational, with smarT.NC and according to ISO
Programming support	TNCguide presents user information directly on the iTNC 530
DXF converter option	Download contours and machining positions from DXF files
Program memory	Hard disk with 25 GB minimum
Position data coordinates	Nominal positions in Cartesian or polar coordinates, dimensions absolute or incremental, in mm or inches; actual position capture
Input resolution and display step	To 0.1 µm or 0.0001°
Block processing time	0.5 ms (3-D straight line without radius compensation at 100 % PLC utilization)
High speed cutting	Motion control with minimum jerk
FK free contour programming	HEIDENHAIN conversational with graphical support
Coordinate transformation	<ul style="list-style-type: none"> • Datum shift, rotation, mirror image, scaling factor (axis-specific) • Tilting the working plane, PLANE function (option)
Fixed cycles	For drilling and milling; data input with graphical support
Touch probe cycles	For tool measurement, workpiece alignment, workpiece measurement and workpiece presetting
Graphics	For programming and program verification
Cutting-data tables	Yes
Parallel operation	Program run and programming with graphics
Data interface	<ul style="list-style-type: none"> • Ethernet 100BaseT • USB 1.1 • RS-232-C/V.24 and RS-422/V.11 (max. 115200 baud)
Remote control and diagnosis	TeleService
Visual display unit	15-inch color flat-panel display (TFT)
Axis feedback control	<ul style="list-style-type: none"> • Feedforward control or following error • Integrated digital drive control with integrated inverter
Adaptive feed rate control option	AFC adjusts the contouring feed rate to the spindle power ¹⁾
DCM collision monitoring option	Dynamic monitoring of the working space for possible collisions with machine components ¹⁾
Integrated PLC	Approx. 16000 logic commands
Accessories	<ul style="list-style-type: none"> • Electronic handwheel • TS workpiece touch probe and TT or TL tool touch probe
Dual-processor version option	With additional Windows XP operating system as user interface

¹⁾This feature must be implemented by the machine tool builder

TNC 320, TNC 620 Contouring Controls

For Milling, Drilling and Boring Machines

The HEIDENHAIN **TNC 320** and **TNC 620** controls are compact but versatile contouring controls. Thanks to their flexible operation—workshop-oriented programmability with HEIDENHAIN conversational programming or offline programming—and their scope of features, they are especially suited for use on universal milling, drilling and boring machines for the following:

- Series and single-part production
- Toolmaking
- Machine building
- Research and development
- Prototypes and pilot plants
- Repair departments
- Training and education facilities

Thanks to its **digital design**, the **TNC 620** has control over the machine's entire drive system. Not only does the field-proven digital drive technology from HEIDENHAIN make high contour fidelity and rapid machining at high speeds possible, but also all control components of the TNC 620 are connected via digital interfaces.



	TNC 320	TNC 620
Axes	3 axes + spindle Optional 4th and 5th axis (with noncontrolled spindle)	3 axes + spindle Optional 4th and 5th axes
Interpolation	<ul style="list-style-type: none"> • Linear in 4 axes • Circular in 2 axes • Helical, superimposition of circular and straight paths • Cylinder surface (option) 	<ul style="list-style-type: none"> • Linear: in 4 axes (optionally 5) • Circular: in 2 (optionally 3) axes • Helical, superimposition of circular and straight paths • Cylinder surface (option)
Programming	<ul style="list-style-type: none"> • HEIDENHAIN conversational • DIN/ISO (program input via soft keys or via external USB keyboard) 	
	–	FK free contour programming (option19)
Programming aids	TNCguide presents user information directly on the TNC	
Program memory	300 MB	
Position data coordinates	<ul style="list-style-type: none"> • Positions in Cartesian or polar coordinates • Incremental or absolute dimensions • Display and input in mm or inches • Actual position capture 	
Input resolution and display step	To 1 µm or 0.001°	To 1 µm or 0.001° Optionally to 0.01 µm or 0.00001°
Block processing time	6 ms	6 ms; optionally 1.2 ms
Coordinate transformation	<ul style="list-style-type: none"> • Datum shift, rotation, mirror image, scaling factor (axis-specific) • Tilting the working plane, PLANE function (option) 	
Fixed cycles	Drilling, tapping, thread cutting, reaming, and boring; cycles for hole patterns (circular and linear), multipass milling of plane surfaces, roughing and finishing of pockets, slots and studs	
Touch probe cycles	For tool measurement, workpiece alignment, workpiece measurement and presetting (option with TNC 620)	
Graphics	For programming and program verification (option with TNC 620); graphic support with cycle programming	
Parallel operation	Programming during program run, program-run graphics (option with TNC 620)	
Data interface	<ul style="list-style-type: none"> • Ethernet 100BaseT • USB 1.1 • RS-232-C/V.24 and RS-422/V.11 (max. 115200 baud) 	
Visual display unit	Flat-panel color display, 15-inch	
Axis feedback control	Feedforward control or following error	
	–	Integrated digital drive control for synchronous and asynchronous motors
Interfacing to the Machine	Via integrated programmable logic controller (PLC)	
	Inputs/outputs expandable via PL 510	Inputs/outputs via PL 6000
Accessories	<ul style="list-style-type: none"> • HR electronic handwheels • TS workpiece touch probe and TT tool touch probe 	

Accessories

Electronic Handwheels

With the electronic handwheel from HEIDENHAIN, you can use the feed drive to make very precise movements in the axis slides in proportion to the rotation of the handwheel. As an option, the handwheels are available with mechanical detent.

HR 410 and HR 420 portable handwheels

The axis keys and certain functional keys are integrated in the housing. It allows you to switch axes or setup the machine at any time—and regardless of where you happen to be standing. The HR 420 also features a display for the position value, the feed rate and spindle speed, the operating mode and other functions, as well as an override potentiometer for feed rate and spindle speed.



HR 420

HR 410

HR 130 and HR 150 panel-mounted handwheels

Panel-mounted handwheels from HEIDENHAIN can be integrated in the machine operating panel or be built-in at another location on the machine. Up to three HR 150 electronic handwheels can be connected through an adapter.



HR 130 for integration in the machine operating panel

Programming Stations

The iTNC and TNC 320/620 programming stations enable you to program in plain language just as you do at the machine, but away from the noise and distractions of the shop floor.

Creating programs

Programming, testing and optimizing HEIDENHAIN conversational or ISO programs with the programming station substantially reduces machine idle times. You do not need to change your way of thinking. At the programming station you program on the same keyboard as at the machine. Of course you can also use the alternative smarT.NC operating mode on the iTNC programming station.

Training with the programming station

Because the programming stations are based on the respective control software, they are ideally suited for apprentice and advanced training.

TNC training in schools

Since they can be programmed in ISO as well as in plain language format, the programming stations can also be used in schools for NC programming training.

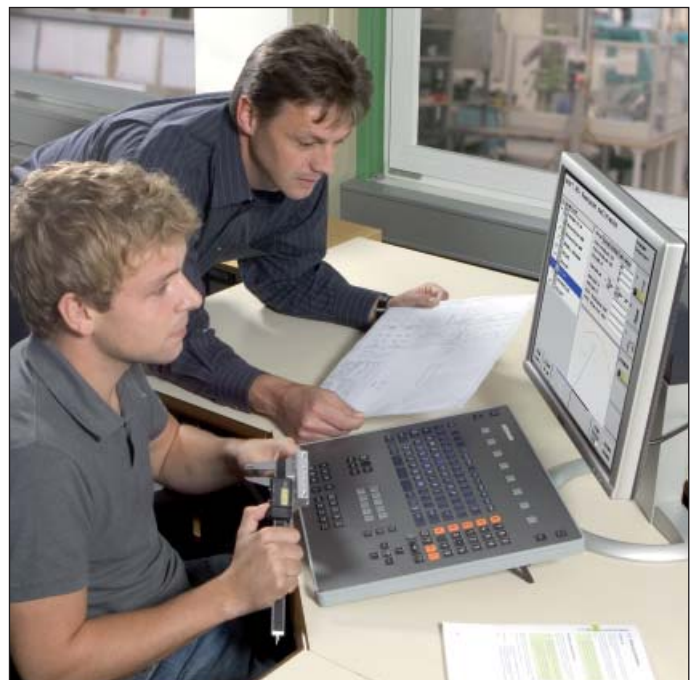

Tool and Workpiece Setup and Measurement

Workpiece Touch Probes

The **TS workpiece touch probes** from HEIDENHAIN help you perform setup, measuring and inspection functions directly on the machine tool.

The stylus of a TS touch trigger probe is deflected upon contact with a workpiece surface. At that moment the TS generates a trigger signal that, depending on the model, is transmitted either by cable or over an infrared beam to the control.

The control simultaneously saves the actual position values as measured by the machine axis encoders, and uses this information for further processing. The trigger signal is generated through a wear-free optical switch that ensures high reliability.

Touch probe with **cable connection for signal transmission** for machines with manual tool change:

- TS 220** – TTL version
- TS 230** – HTL version

Touch probes with **infrared signal transmission** for machines with automatic tool change:

- TS 440** – Compact dimensions
- TS 444** – Compact dimensions, battery-free power supply through integrated air turbine generator over central compressed air supply
- TS 640** – Standard touch probe with wide-range infrared transmission
- TS 740** – High probing accuracy and repeatability, low probing force



SE 540



SE 640



TS 220



TS 440



TS 640



	TS 220	TS 230	TS 440/TS 444/TS 640	TS 740
Probe repeatability	2 σ \leq 1 μ m (at \leq 1 m/min)			2 σ \leq 0.25 μ m (at \leq 0.25 m/min)
Permiss. stylus deflection	Approx. 5 mm in all directions (at stylus length of 40 mm)			
Power supply	5 V \pm 5 % from the NC	10 to 30 V from the NC	TS 440/TS 640/TS 740: Two batteries, 1 to 4 V TS 444: through air turbine generator	
Interface to control	TTL signal levels	HTL signal levels	HTL signal levels via SE transceiver unit	
Signal transmission	Via cable		Infrared beam with 360° range transmission to SE transceiver unit <ul style="list-style-type: none"> • SE 540: for integration in spindle head • SE 640: for integration in the machine's workspace • SE 642: common SE for TS and TT 449 	
Probe velocity	\leq 3 m/min			\leq 0.25 m/min
Styli	Ball-tip styli in various diameters and lengths			
Protection EN 60529	IP 55		IP 67	

Tool Touch Probes

Tool measurement on the machine shortens non-productive times, increases machining accuracy and reduces scrapping and reworking of machined parts. With the tactile TT touch probes and the contact-free TL laser systems, HEIDENHAIN offers two completely different possibilities for tool measurement.

With their rugged design and high degree of protection, these tool touch probes can be installed directly within the machine tool's work envelope. Tool measurement is possible at any time: before machining, between two machining steps, or after machining is done.

Touch probes

The TT 140 and TT 449 are 3-D touch trigger probes for tool measurement and inspection. The disk-shaped probe contact of the TT is deflected during physical probing of a tool. At that moment the TT generates a trigger signal that is transmitted to the control, where it is processed further. The trigger signal is generated through a wear-free optical switch that ensures high reliability.

TT 140

- Signal transmission to the NC over **connecting cable**

TT 449

- Signal transmission over **infrared beam** to transmitter/receiver unit
- The SE 642 is a common transmitter/receiver unit for tool and workpiece touch probes with infrared transmission



TT 140



TT 449

	TT 140	TT 449
Probing method	Physical probing in three dimensions: $\pm X, \pm Y, +Z$	
Probe repeatability	$2 \sigma \leq 1 \mu\text{m}$ (probing velocity 1 m/min)	
Permissible deflection of probe contact	Approx. 5 mm in all directions	
Power supply	10 to 30 V from the NC	
Interface to control	HTL signal levels	HTL signal levels via SE transceiver unit
Signal transmission	Via cable	Via infrared beam with 360° range transmission to SE 642 transceiver unit
Probe contact	Hardened steel disk $\varnothing 40 \text{ mm}$ or $\varnothing 25 \text{ mm}$	
Protection EN 60529	IP 67	

TL laser systems

The TL Micro and TL Nano laser systems can measure tools at the rated speed without making contact. With the aid of the included measuring cycles you can measure tool lengths and diameters, inspect the form of the individual teeth and check for tool wear or breakage. The control automatically saves the results of measurement in the tool table.



	TL Nano	TL Micro 150	TL Micro 200	TL Micro 350
Probing method	Contact-free with laser beam in two dimensions: $\pm X$ (or $\pm Y$), $+Z$			
Tool diameter Central measurement	0.03 to 37 mm	0.03 to 30 mm	0.03 to 80 mm	0.03 to 180 mm
Repeatability	$\pm 0.2 \mu\text{m}$		$\pm 1 \mu\text{m}$	
Spindle speed	Optimized for individual tooth measurement on standard or HSC spindles ($> 30\,000 \text{ min}^{-1}$)			
Lasers	Visible red-light laser with beam focused at center of system; protection class 2 (IEC 825)			
Power supply	24 V from the NC			
Interface to control	HTL signal levels			
Protection EN 60529	IP 68 (when connected, with sealing air)			
Tool cleaning	Integral blowing unit			

Measured Value Acquisition and Display

Digital Readouts

Digital readouts serve to visualize the values measured with linear encoders, length gauges, rotary encoders or angle encoders. Areas of application include:

- Measuring and inspection equipment
- Dividing apparatuses
- Monitoring of measuring equipment
- Manual machine tools
- Measuring machines

Position displays from HEIDENHAIN are designed to be highly **user-friendly**. Typical characteristics:

- Optimally readable, graphic flat panel display
- Simple, logically arranged keypad
- Ergonomically designed push-button keys
- Splash-protected front panel
- Sturdy die-cast housing
- Conversational user guidance with help and graphic functions
- User-friendly functions for easier operation of manual machines and equipment
- Reference mark evaluation for distance-coded and single reference marks
- Problem-free installation, maintenance-free operation
- Fast payback with economical use

Position display units from HEIDENHAIN feature a **data interface** for further processing in the higher-level electronics or simply to print out the measured values.

Interface Electronics

Interface electronics from HEIDENHAIN adapt the encoder signals to the interface of the subsequent electronics.

Counter cards for installation in PCs or subsequent electronics simplify the realization of **customized solutions** such as measuring electronics, controls or automation devices.

With its integrated counting function, the **External Interface Box (EIB)** converts the sinusoidal output signals from HEIDENHAIN encoders into absolute position values to simplify connection to various control systems.



Position display units for maximum productivity

Position display units for metrological applications offer numerous functions for **measured data acquisition** and **statistical evaluation** of measured values.

TOOL-CHEK is a digital readout with special features for use on tool presetters.

QUADRA-CHEK digital readouts for profile projectors, measuring microscopes, 2-D and video measuring machines as well as CMMs measure points on **2-D contours**, depending on the version either automatically or manually by crosshairs, by optical edge detection or by video camera with real-time display of the live picture and integrated image processing. For **3-D contours**, such as planes, cylinders, cones and spheres, the measurement points are saved by probing with a touch probe.

In the optional **CNC version**, they also operate as full-fledged controls for axis positioning and can automatically execute measuring programs.



PC solution for a measuring machine



Position display on a milling machine

Digital readouts for manual machine tools increase your productivity. You save time, increase the dimensional accuracy of the finished workpiece and enjoy user-friendly operation.

Regardless of whether you're installing on new equipment or retrofitting machines already in operation, digital readouts can easily be retrofitted to any model of machine or type of equipment, whatever the application or number of displayed axes.

Practice-oriented functions and cycles are available for various applications. The distance-to-go display feature with graphic positioning aid allows you to approach the next nominal position quickly and reliably simply by traversing to a display value of zero. And POSITIP speeds up small-batch production—repetitive machining sequences can be saved as a program.

Precise manufacturing made easy: Together with linear encoders from HEIDENHAIN, the digital readouts measure the axis movements directly. The backlash caused by mechanical transfer elements such as lead screws, racks and gears therefore has no influence.

Digital Readouts for Metrology Applications		Series	Page
For measuring and positioning equipment	For one axis	ND 200	52
For multipoint inspection apparatuses and SPC	For up to eight axes	ND 2100G GAGE-CHEK	52
For tool presetters	For two axes	ND 1200T TOOL-CHEK	52
For profile projectors, measuring microscopes, 2-D and video measuring machines as well as CMMs	For up to four axes	ND 1000 QUADRA-CHEK IK 5000 QUADRA-CHEK	53
Digital Readouts for Manually Operated Machine Tools			
For milling machines, lathes and positioning devices	For up to six axes For up to three axes	POSITIP 880 ND 780 ND 500	54
Interface Electronics	Counter card for PCs External Interface Box	IK 220 EIB	55

Digital Readouts

For Metrology Applications

For many metrology applications, ranging from simple measuring stations to complex inspection systems with multiple measuring points, HEIDENHAIN supports you with the appropriate digital readouts or PC solutions.

Their functionality always orients itself to the specific application. Whether it is an SPC inspection station, a tool presetter, a profile projector, a measuring microscope, or a coordinate measuring machine, the **digital readouts and PC solutions for metrological applications** from HEIDENHAIN are the right choice for measurement tasks. There is even a CNC option for the automation of measurement tasks.



ND 287



ND 2100 G

	ND 280	ND 287	ND 2100 G GAGE-CHEK	ND 1202 T TOOL-CHEK
Application	Measuring and inspection equipment	<ul style="list-style-type: none"> • Measurement equipment • Testing devices • SPC inspection stations 	<ul style="list-style-type: none"> • Multipoint inspection apparatuses • SPC inspection stations 	Tool presetters
Axes¹⁾	1	1	4 or 8	2 (XZ)
Encoder inputs	$\sim 1 V_{PP}$ $\sim 11 \mu A_{PP}$ or EnDat 2.2		$\sim 1 V_{PP}$ or \square TTL (other interfaces upon request)	
Display	Monochrome flat-panel display	Color flat-panel display	5.7" color flat-panel display	5.7" monochrome flat-panel display
Function	–	<ul style="list-style-type: none"> • Sorting and tolerance checking • Measurement series with min./max. value storage • Functions for statistical process control (SPC) • Graphic display of measurement results • Storage of measured values 	<ul style="list-style-type: none"> • Programming of up to 100 parts • Entry of any formulas, combinations and variables • Output of measurement results 	<ul style="list-style-type: none"> • Point measurement with crosshairs • 99 tool adapters • Memory for 300 tools • Entry of tolerances • Circle and angle measurement • Label printing
Data interfaces	USB; RS-232-C	USB; RS-232-C; Ethernet (option)	USB; RS-232-C	

¹⁾ Depending on version

²⁾ Possible combinations depending on version



ND 1200



ND 1300

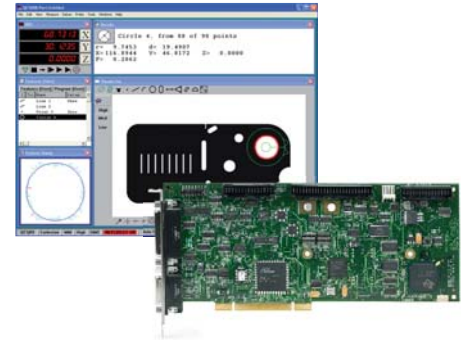

IK 5000

ND 1100 QUADRA-CHEK	ND 1200 QUADRA-CHEK	ND 1300 QUADRA-CHEK	ND 1400 QUADRA-CHEK	IK 5000 QUADRA-CHEK
<ul style="list-style-type: none"> Positioning equipment Measuring fixtures Manual coordinate measuring machines 	<ul style="list-style-type: none"> Profile projectors Measuring microscopes 2-D measuring machines 	<ul style="list-style-type: none"> Profile projectors Measuring microscopes Video measuring machines 	<ul style="list-style-type: none"> Manual coordinate measuring machines 	<ul style="list-style-type: none"> Profile projectors Measuring microscopes Video measuring machines CMMs
2, 3 or 4	XY, XYQ or XYZ	XY, XYQ, XYZ or XYZQ	XYZQ	XYQ, XYZ or XYZQ
\sim 1 V _{pp} or \square TTL (other interfaces upon request)				
5.7" monochrome flat-panel display		8.4" color flat-panel display (touch screen)		Via PC screen
Measurement series with MIN/MAX display	Measurement of 2-D features		Measurement of 2-D and 3-D features	Measurement of 2-D features
<i>Optional:</i> Touch-probe connection	<ul style="list-style-type: none"> Measure Magic function Programming of features and parts Entry of tolerances 			
	Point measurement with crosshairs		<ul style="list-style-type: none"> Points measured via touch probe, crosshairs or rigid probing element Five coordinate systems can be stored Touch-probe management 	Point measurement with crosshairs <i>Depending on version:</i> <ul style="list-style-type: none"> Measurement of 3-D features Automatic edge sensing via optical edge detector Video edge detection and live image display Point measurement by touch probe (also TP 200) CNC axis control and autofocus
	<i>Optional:</i> Automatic edge sensing via optical edge detector	<i>Optional²⁾:</i> <ul style="list-style-type: none"> Automatic edge sensing via optical edge detector Video edge detection and live image display Image archiving Zoom and light control, programmable CNC axis control and autofocus 		
USB; RS-232-C				PCI (PC interface)

Digital Readouts

For Manually Operated Machine Tools

HEIDENHAIN digital readouts for manually operated machine tools have universal application: In addition to standard tasks on milling, drilling and boring machines and lathes, they also offer ideal solutions for many applications on machine tools, measuring and testing equipment, and special machines—in fact all machines where axis slides are moved manually.



ND 780



ND 523

	POSITIP 880	ND 780	ND 522	ND 523
Application	Milling, drilling, boring machines and lathes			
Description	Color flat-panel display, program memory, splash-proof full-travel keyboard	Monochrome flat-panel display, splash-proof full-travel keyboard	Monochrome flat-panel display, membrane keyboard	
Axes	Up to 6 axes	Up to 3 axes	2 axes	3 axes
Encoder inputs	~ 1 V _{PP} or EnDat 2.1	~ 1 V _{PP}	□ TTL	
Display step	10 μm, 5 μm, 1 μm or finer		5 μm (with LS 328C/LS 628C)	
Datums	<i>Milling: 99; turning: 1</i>	10		
Tool data	For 99 tools	For 16 tools		
Programming	Max. 999 program blocks per program	—		
Functions	Contour monitoring with magnify function	Contour monitoring		
For milling, drilling and boring machines	<ul style="list-style-type: none"> • Calculation of positions for hole patterns (circular and linear patterns) • Cutting data calculator 			
	Probing functions for datum acquisition with the KT edge finder: "Edge," "Centerline" and "Circle center"		—	
	Positioning aids for milling and roughing rectangular pockets	—		
For turning	<ul style="list-style-type: none"> • Radius/diameter display • Separate or sum display for Z and Z₀ • Taper calculator • Freezing the tool position for back-off 			
	<ul style="list-style-type: none"> • Oversize allowances • Cycle for area clearance 	—		
Interfaces	Edge finder, switching functions (option)		—	
	RS-232-C/V.24, Centronics	RS-232-C/V.24	USB	

Interface Electronics

IK 220

Universal PC counter card

The IK 220 is an expansion board for PCs for recording the measured values of two incremental or absolute linear or angle encoders. The subdivision and counting electronics subdivide the sinusoidal input signals up to 4096-fold. A driver software package is included in delivery.



	IK 220			
Encoder inputs switchable	~ 1 V _{PP}	~ 11 μA _{PP}	EnDat 2.1	SSI
Connection	Two D-sub connections (15-pin), male			
Input frequency	≤500 kHz	≤33 kHz	–	
Cable length	≤ 60 m		≤ 50 m	≤ 10 m
Signal subdivision	Up to 4096-fold			
Data register for measured values (per channel)	48 bits (44 bits used)			
Internal memory	For 8 192 position values			
Interface	PCI bus (plug and play)			
Driver software and demonstration program	For Windows 98/NT/2000/XP in VISUAL C++, VISUAL BASIC and BORLAND DELPHI			
Dimensions	Approx. 190 mm × 100 mm			

EIB Series

External Interface Box

The External Interface Box subdivides the sinusoidal output signals from HEIDENHAIN encoders and converts them into absolute position values with the aid of the integrated counting function. When the reference mark is crossed, the position value is defined with respect to a fixed reference point.



EIB 392

	EIB 192	EIB 392
Design	Housing	Connector
Degree of protection	IP 65	IP 40
Encoder input	~ 1 V _{PP}	
Connection	M23 connector (12-pin), female	<ul style="list-style-type: none"> D-sub connector (15-pin) M23 connector (12-pin), female
Signal subdivision	≤ 16384-fold	
Output	Absolute position values	
Interface	<i>EIB 192/EIB 392</i> : EnDat 2.2 <i>EIB 192F/EIB 392F</i> : Fanuc Serial Interface <i>EIB 192M/EIB 392M</i> : Mitsubishi High Speed Serial Interface	
Power supply	5 V ± 5 %	

For More Information

Brochures, data sheets and CD-ROMs

The products shown in this General Catalog are described in more detail in separate documentation, including complete specifications, signal descriptions and dimension drawings in English and German (other languages available upon request).

HEIDENHAIN on the Internet

Visit our home page at www.heidenhain.com for up-to-date information on:

- The company
- The products

Our web site also includes:

- Technical articles
- Press releases
- Addresses
- TNC training programs

Length Measurement



Brochure
Linear Encoders
for Numerically Controlled Machine Tools

Contents:
Absolute Linear Encoders
LC
Incremental Linear Encoders
LB, LF, LS



Brochure
Length Gauges

Contents:
HEIDENHAIN-SPECTO
HEIDENHAIN-METRO
HEIDENHAIN-CERTO



Brochure
Exposed Linear Encoders

Contents:
Incremental Linear Encoders
LIP, PP, LIF, LIDA

Angle Measurement

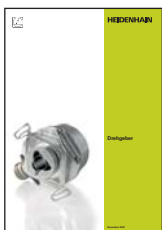

Brochure
Rotary Encoders

Contents:
Absolute Rotary Encoders
ECN, EQN, ROC, ROQ
Incremental Rotary Encoders
ERN, ROD



Brochure
Angle Encoders with Integral Bearing

Contents:
Absolute Angle Encoders
RCN
Incremental Angle Encoders
RON, RPN, ROD



Brochure
Encoders for Servo Drives

Contents:
Rotary Encoders
Angle Encoders
Linear Encoders



Brochure
Angle Encoders without Integral Bearing

Contents:
Incremental Angle Encoders
ERA, ERP

Machine Tool Control



Brochure
iTNC 530 Contouring Control

CD-ROM
iTNC Presentation

Contents:
Information for the user



OEM Brochure
iTNC 530 Contouring Control

Contents:
Information for the machine tool builder



Brochures
TNC 320 Contouring Control
TNC 620 Contouring Control

Contents:
Information for the user



OEM Brochure
TNC 320 Contouring Control
TNC 620 Contouring Control

Contents:
Information for the machine tool builder



Brochure
MANUALplus 620 Contouring Control

Contents:
Information for the user



OEM Brochure
MANUALplus 620 Contouring Control

Contents:
Information for the machine tool builder

Setup and Measurement



Brochure, CD-ROM
Touch Probe Systems

Contents:
Tool Touch Probe
TT, TL
Workpiece Touch Probe
TS



Brochure
Measuring Systems for Machine Tool Inspection and Acceptance Testing

Contents:
Incremental Linear Encoders
KGM, VM

Measured Value Acquisition and Display



Brochure
Digital Readouts
for Metrology Applications

Contents:
Position Display Units
ND 1100, ND 1200, ND 1300, ND 1400
ND 1200T, ND 2100G



Brochure, CD-ROM
Position Display Units Linear Encoders
for Manually Operated Machine Tools

Contents:
Position Display Units
ND 200, ND 500, ND 700, POSITIP
Linear Encoders
LS 300, LS 600

HEIDENHAIN is represented by subsidiaries in all important industrial nations. In addition to the addresses listed here, there are many service agencies located worldwide. For more information, visit our Internet site or contact HEIDENHAIN in Traunreut, Germany.

DR. JOHANNES HEIDENHAIN GmbH

Dr.-Johannes-Heidenhain-Straße 5

83301 Traunreut, Germany

☎ +49 8669 31-0

FAX +49 8669 5061

E-mail: info@heidenhain.de

www.heidenhain.de

Germany

HEIDENHAIN Technisches Büro Nord

12681 Berlin, Deutschland

☎ 030 54705-240

E-Mail: tbn@heidenhain.de

HEIDENHAIN Technisches Büro Mitte

08468 Heinsdorfergrund, Deutschland

☎ 03765 69544

E-Mail: tbn@heidenhain.de

HEIDENHAIN Technisches Büro West

44379 Dortmund, Deutschland

☎ 0231 618083-0

E-Mail: tbw@heidenhain.de

HEIDENHAIN Technisches Büro Südwest

70771 Leinfelden-Echterdingen, Deutschland

☎ 0711 993395-0

E-Mail: tbsw@heidenhain.de

HEIDENHAIN Technisches Büro Südost

83301 Traunreut, Deutschland

☎ 08669 31-1345

E-Mail: tbsso@heidenhain.de

Europe

AT HEIDENHAIN Techn. Büro Österreich

Dr.-Johannes-Heidenhain-Straße 5

83301 Traunreut, Germany

☎ +49 8669 31-1337

www.heidenhain.de

BA Bosnia and Herzegovina → SL

BE HEIDENHAIN NV/SA

Pamelse Klei 47

1760 Roosdaal, Belgium

☎ +32 54 343158

www.heidenhain.be

BG ESD Bulgaria Ltd.

G.M. Dimitrov Blvd.,

bl. 60, entr. G, fl. 1, ap 74

Sofia 1172, Bulgaria

☎ +359 2 9632949

www.esd.bg

BY Belarus

GERTNER Service GmbH

Vogelsangerweg 142222

50354 Huerth, Germany

☎ +49 2233 96314-0

www.gertner.biz

CH HEIDENHAIN (SCHWEIZ) AG

Vieristrasse 14

8603 Schwerzenbach, Switzerland

☎ +41 44 8062727

www.heidenhain.ch

CZ HEIDENHAIN s.r.o.

Dolnometolupska ul. 12b

102 00 Praha 10, Czech Republic

☎ +420 272658131

www.heidenhain.cz

DK TP TEKNIK A/S

Korskildelund 4

2670 Greve, Denmark

☎ +45 70 100966

www.tp-gruppen.dk

ES FARRESA ELECTRONICA S.A.

Les Corts, 36 bajos

08028 Barcelona, Spain

☎ +34 934092491

www.farresa.es

FI HEIDENHAIN Scandinavia AB

Mikkelänkallio 3

02770 Espoo, Finland

☎ +358 9 8676476

www.heidenhain.fi

FR HEIDENHAIN FRANCE sarl

2 avenue de la Cristallerie

92310 Sèvres, France

☎ +33 0141143000

www.heidenhain.fr

GB HEIDENHAIN (G.B.) Limited

200 London Road, Burgess Hill

West Sussex RH15 9RD, United Kingdom

☎ +44 1444 247711

www.heidenhain.co.uk

Americas

AR NAKASE SRL.

Calle 49 Nr. 5764

B1653AOX Villa Ballester,

Provincia de Buenos Aires, Argentina

☎ +54 11 47684242

www.heidenhain.com.ar

BR DIADUR Indústria e Comércio Ltda.

Rua Sérvia, 329 Socorro, Santo Amaro

04763-070 – São Paulo – SP, Brazil

☎ +55 11 5696-6777

www.heidenhain.com.br

CA HEIDENHAIN CORPORATION

Canadian Regional Office

11-335 Admiral Blvd., Unit 11

Mississauga, Ontario L5T2N2, Canada

☎ +1 905 670-8900

www.heidenhain.com

MX HEIDENHAIN CORPORATION MEXICO

Av. Las Américas 1808

Fracc. Valle Dorado

20235 Aguascalientes, Ags., Mexico

☎ +52 449 9130870

E-mail: info@heidenhain.com

US HEIDENHAIN CORPORATION

333 East State Parkway

Schaumburg, IL 60173-5337, USA

☎ +1 847 490-1191

www.heidenhain.com

VE Maquinaria Diekmann S.A.

Av. Humbolt (Prol. Leoncio Martinzes)

Urb. Las Acacias Aptdo. 40.112

Caracas, 1040-A, Venezuela

☎ +58 212 6325410

E-mail: purchase@diekmann.com.ve

Africa

ZA MAFEMA SALES SERVICES C.C.

107 16th Road, Unit B3

Tillbury Business Park, Randjespark

1685 Midrand, South Africa

☎ +27 11 3144416

www.heidenhain.co.za

Australia

AU FCR Motion Technology Pty. Ltd

Automation Place, Unit 6,

38-40 Little Boundary Road

Laverton North 3026, Victoria, Australia

☎ +61 3 93626800

E-mail: vicsales@fcrmotion.com

GR	MB Milionis Vassilis 38, Scoufa Str., St. Dimitrios 17341 Athens, Greece ☎ +30 210 9336607 www.heidenhain.gr	PL	APS Husarska 19B 02-489 Warszawa, Poland ☎ +48 228639737 www.apserwis.com.pl	SK	KOPRETINA TN s.r.o. Suvoz 1660 91101 Trencin, Slovakia ☎ +421 32 7401700 www.kopretina.sk
HR	Croatia → SL	PT	FARRESA ELECTRÓNICA LDA. Rua do Espido, 74 C 4470 - 177 Maia, Portugal ☎ +351 229478140 www.farresa.pt	SL	Posredništvo HEIDENHAIN NAVO d.o.o. Sokolska ulica 46 2000 Maribor, Slovenia ☎ +386 2 4297216 www.heidenhain-hubl.si
HU	HEIDENHAIN Kereskedelmi Képviselet Grassalkovich út 255. 1239 Budapest, Hungary ☎ +36 1 4210952 www.heidenhain.hu	RO	HEIDENHAIN Reprezentantă România Str. Saturn 5 sc. A, ap. 6, Braşov, 500338, Romania ☎ +40 726235914 www.heidenhain.ro	TR	T&M Mühendislik San. ve Tic. LTD. ŞTİ. Eski Bostanci Yolu, KEYAP Carsi Sitesi G1 Blok, No. 119 B 34728 Umraniye-Istanbul, Turkey ☎ +90 216 3141111 www.heidenhain.com.tr
IT	HEIDENHAIN ITALIANA S.r.l. Via Asiago, 14 20128 Milano, Italy ☎ +39 02270751 www.heidenhain.it	RS	Serbia → BG	UA	Gertner Service GmbH Büro Kiev 01133 Kiev, Ukraine bul. L. Ukrainki 14a/40 ☎ +38 044 2357574 www.gertner.biz
ME	Montenegro → SL	RU	OOO HEIDENHAIN Chasovaya Street 23 A 125315 Moscow, Russia ☎ +7 495 931-9646 www.heidenhain.ru		
MK	Macedonia → BG	SE	HEIDENHAIN Scandinavia AB Storsättragränd 5 12739 Skärholmen, Sweden ☎ +46 8 53193350 www.heidenhain.se		
NL	HEIDENHAIN NEDERLAND B.V. Copernicuslaan 34, 6716 BM Ede, Netherlands ☎ +31 318 581800 www.heidenhain.nl				
NO	HEIDENHAIN Scandinavia AB Orkdalsveien 15 7300 Orkanger, Norway ☎ +47 72480048 www.heidenhain.no				

Asia

CN	DR. JOHANNES HEIDENHAIN (CHINA) Co., Ltd. No. 6, TianWeiSanJie, Area A. Beijing Tianzhu Airport Industrial Zone Shunyi District, Beijing 101312, China ☎ +86 10-80420000 www.heidenhain.com.cn	IN	HEIDENHAIN Optics & Electronics India Private Limited Citilights Corporate Centre No. 1, Vivekananda Road, Off Spur Tank Road Srinivasa Nagar, Chetpet Chennai – 600 031, India ☎ +91 44 3023-4000 www.heidenhain.in	PH	Machinebanks` Corporation 482 G. Araneta Avenue, Quezon City, Philippines 1113 ☎ +63 2 7113751 E-mail: info@machinebanks.com
HK	HEIDENHAIN LTD Unit 1706 & 07, Apec Plaza 49 Hoi Yuen Road, Kwun Tong Kowloon, Hong Kong ☎ +852 27591920 E-mail: service@heidenhain.com.hk	JP	HEIDENHAIN K.K. Kudan Center Bldg. 10th Floor Kudankita 4-1-7, Chiyoda-ku Tokyo 102-0073, Japan ☎ +81 3 3234-7781 www.heidenhain.co.jp	SG	HEIDENHAIN PACIFIC PTE LTD. 51, Ubi Crescent Singapore 408593 ☎ +65 6749-3238 www.heidenhain.com.sg
ID	PT Servitama Era Toolsindo GTS Building, Jl. Pulo Sidik Block R29 Jakarta Industrial Estate Pulogadung Jakarta 13930, Indonesia ☎ +62 21 46834111 E-mail: ptset@group.gts.co.id	KR	HEIDENHAIN LTD. 201 Namsung Plaza (9th Ace Techno Tower) 345-30, Gasan-Dong, Geumcheon-Gu, Seoul, Korea, 153-782 ☎ +82 2 2028-7430 www.heidenhain.co.kr	TH	HEIDENHAIN (THAILAND) LTD 53/72 Moo 5 Chaloem Phra Kiat Rama 9 Road Nongbok, Pravate, Bangkok 10250, Thailand ☎ +66 2 398-4147-8 www.heidenhain.co.th
IL	NEUMO VARGUS MARKETING LTD. Post Box 57057 34-36, Itzhak Sade St. Tel Aviv 61570, Israel ☎ +972 3 5373275 E-mail: neumo@neumo-vargus.co.il	MY	ISOSERVE Sdn. Bhd No. 6 - 1 Jalan 2/96A Taman Cheras Makmur 56100 Kuala Lumpur, Malaysia ☎ +60 3 91320685 E-mail: isoserve@po.jaring.my	TW	HEIDENHAIN Co., Ltd. No. 29, 33rd Road Taichung Industrial Park Taichung 40768, Taiwan R.O.C. ☎ +886 4 23588977 www.heidenhain.com.tw
				VN	AMS Advanced Manufacturing Solutions Pte Ltd 310 (12A-13A) Le Hong Phong Street, District 10, HCM City, Việt Nam ☎ +84 8 9123658-8352490 E-mail: davidgoh@amsvn.com

HEIDENHAIN

DR. JOHANNES HEIDENHAIN GmbH

Dr.-Johannes-Heidenhain-Straße 5

83301 Traunreut, Germany

 +49 8669 31-0

 +49 8669 5061

E-mail: info@heidenhain.de

www.heidenhain.de

Zum Abheften hier falzen! / Fold here for filing!

