



IGLIS
⌚

158.100.100

IGLIS
⌚

158.100.100

158.100.100

158.100.100 IGLIS

158.100.100 IGLIS

E2 Tubes



E2 Tubes - protection against hot chips and debris

E2 Energy Tube

Series Zipper, R, R100 and R1000

Laboratory tests and numerous field applications over the past 20 years prove that igus® Energy Chains® and fully enclosed Energy Tubes protect cables used in welding robots and machine tools. For extreme-temperature applications, igus® offers Energy Tubes made from its igumid HT material, which repels hot chips and flying debris reaching 1,562°F (850°C). All standard E2 and E4 Energy Tubes are available made from igumid HT, upon request.

Typical industries and applications

- Tooling machines
- Woodworking machines
- All kind of industries and machines with chip, dirt and dust



iF-Design Awards -
Series R117/118 and Series R68



ESD Classification: Electrically conductive
ESD/ATEX version upon request



Flammability Class
VDE 0304 IIC UL94 HB



Series R - For higher speeds and smooth running

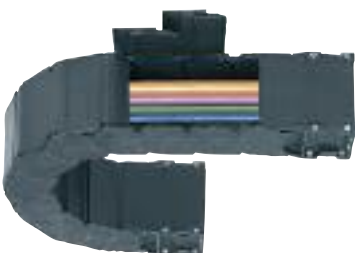

Series R100 - Cost effective alternative, for applications with low and medium speeds





E2 Energy Tubes in chip-area of a tooling machine. Resistant against hot metal chips up to 1,562°F (850°C)



U-shaped supported Energy Tube
for high lateral acceleration



Standing application - R68 Tube -
Note: the first links are supported

RX40 - New Energy Tube with chip repellent design

A world premiere from igus®- a totally redesigned Energy Tube - repels chips, is extremely tight, and can still be opened!

Series RX40 ▶ Page 5.95



Energy Chain System® E2 Tubes Selection Guide

energy chain® configurator 

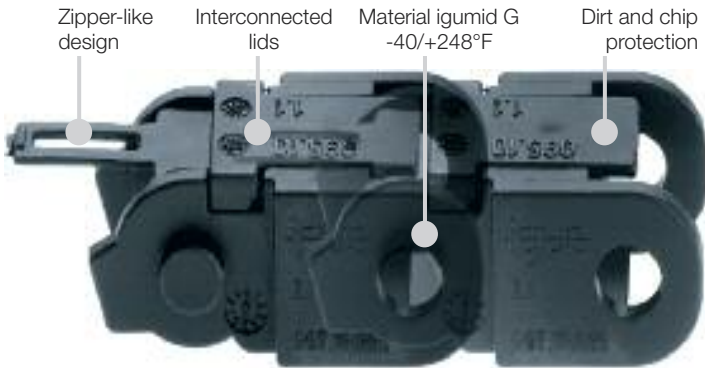

Zipper Energy Tubes against chips and dirt

- Fully enclosed Energy Tube with zipper opening mechanism
- Protection against dirt and chips
- Superfast opening of interconnected lids
- Modular design - tool-free lengthening and shortening
- Small pitch for low noise, smooth operation, high acceleration
- You can find more technical data about the material, chemical resistance, temperatures ► **Design, Chapter 1**

Series	Inner height <i>hi</i>		Inner width <i>Bi</i>		Outer width <i>Ba</i>		Outer height <i>ha</i>		Bending radius <i>R</i>	
	in.	(mm)	in.	(mm)	in.	(mm)	in.	(mm)	in.	(mm)
R07	.41	(10.3)	.39-1.97	(10 - 50)	.65-2.24	(16.5 - 57.0)	.59	(15.0)	1.50-1.89	(38 - 48)
R09	.59	(15.0)	.39-1.97	(10 - 50)	.72-2.29	(18.2 - 58.2)	.76	(19.3)	1.89-3.94	(48 - 100)

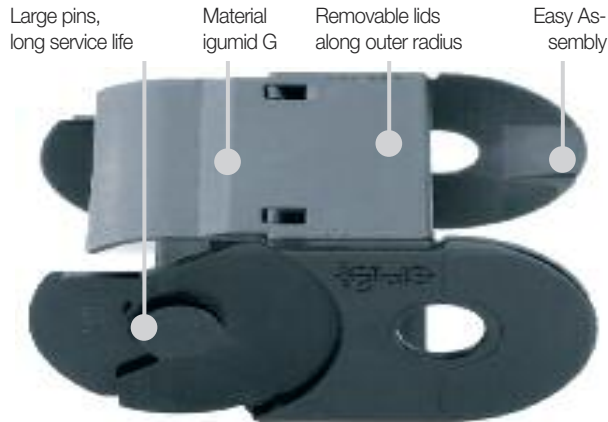

E2 Series R - small pitch for smooth motion

- Protection for cables and hoses against chips (also hot chips)
- Small pitch for low noise, smooth operation
- Smooth, chip repellent exterior
- Lids removable for assembly time reduction
- Double stop dog for strong unsupported lengths
- KMA mounting brackets with attachment capability on all sides
- Very small radii possible due to small pitch
- You can find more technical data about the material, chemical resistance, temperatures ► **Design, Chapter 1**

Series	Inner height <i>hi</i>		Inner width <i>Bi</i>		Outer width <i>Ba</i>		Outer height <i>ha</i>		Bending radius <i>R</i>	
	in.	(mm)	in.	(mm)	in.	(mm)	in.	(mm)	in.	(mm)
R48	.98	(25)	.98-5.12	(25-130)	1.42-5.55	(36-141)	1.42	(36)	2.36-9.84	(60 - 250)
R58	1.38	(35)	1.97-7.87	(50-200)	2.60-8.50	(66-216)	1.97	(50)	2.95-9.84	(75 - 250)
R68	1.77	(45)	1.97-9.84	(50-250)	2.68-10.55	(68-268)	2.52	(64)	3.94-11.81	(100 - 300)

Energy Chain System® E2 Tubes Assembly Instructions

Energy Chains® - Assembling E2 Zipper Energy Tubes



1 Push and click



2 Snap lids together



3 Position and...



4 ...push and snap

Energy Chains® - Separating E2 Zipper Energy Tubes



1 Pull - upward . All lids fit like a "Zipper"



2 Separate lids



1 Release side link



2 Twist and pull apart

Energy Chains® - Assembling E2 Series R48, R58, R68 Energy Tubes



1 Push and click

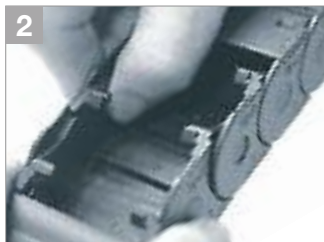

2 Snap in pin



3 Slide lid



4 Push and snap

Energy Chains® - Separating E2 Series R48, R58, R68 Energy Tubes



1 Lever open lid



2 Remove lid



3 Release side-link



4 Twist and pull apart

Energy Chain System® E2 Tubes Selection Guide

energy chain® configurator 

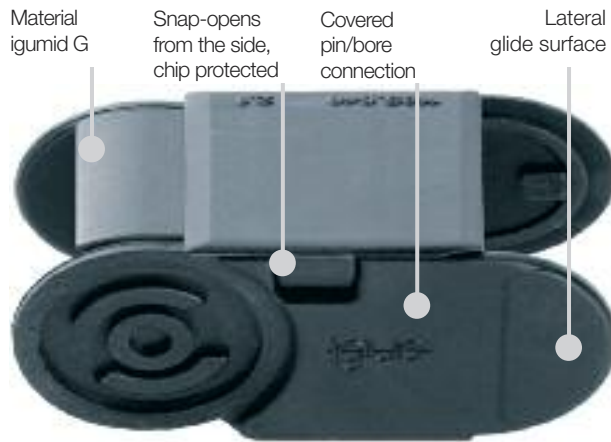

E2 Series R100 - robust and tight

- Very good protection against chips (also hot chips)
- Hinged, snap-open, removable lids along inner or outer radius reduce assembly time
- Space-efficient with optimized ratio of inner dimension to outer dimension
- Double stop dog for long service life and strong unsupported lengths
- Universal KMA mounting brackets with attachment capability on all sides
- You can find more technical data about the material, chemical resistance, temperatures ► **Design, Chapter 1**

Series	Inner height <i>hi</i>		Inner width <i>Bi</i>		Outer width <i>Ba</i>		Outer height <i>ha</i>		Bending radius <i>R</i>	
	in.	(mm)	in.	(mm)	in.	(mm)	in.	(mm)	in.	(mm)
R117/118	.83	(21)	.79-3.94	(20-100)	1.26-4.41	(32-112)	1.10	(28)	2.48-7.09	(63 - 180)
R157/158	1.57	(40)	1.57-7.87	(40-200)	2.20-8.50	(56-216)	1.97	(50)	3.94-9.84	(100 - 250)
R167/168	1.97	(50)	1.97-9.84	(50-250)	2.68-10.55	(68-268)	2.52	(64)	3.94-11.81	(100 - 300)

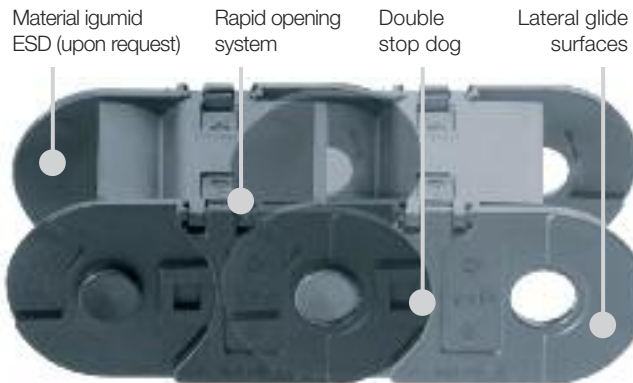

E2 Series R1000

- Enclosed Energy Tube can be used in chip areas (also hot chips)
- Snap-open mechanism, snap-open on left or right
- Opening mechanism accessible from above - rapid opening of the Energy Tube with a screwdriver or by hand
- Lightning-fast closing by hand - Secure fit without additional locking devices
- Secure fit of interior separation even when Energy Tube is open
- You can find more technical data about the material, chemical resistance, temperatures ► **Design, Chapter 1**

Series	Inner height <i>hi</i>		Inner width <i>Bi</i>		Outer width <i>Ba</i>		Outer height <i>ha</i>		Bending radius <i>R</i>	
	in.	(mm)	in.	(mm)	in.	(mm)	in.	(mm)	in.	(mm)
1480	.83	(21)	.59-4.92	(15 - 125)	1.12-5.45	(28.5 - 138.5)	1.10	(28)	2.95-7.09	(75 - 180)
2480	.98	(25)	1.50-4.06	(38 - 103)	2.13-4.69	(54.0 - 119.0)	1.38	(35)	3.94-9.84	(100 - 250)
2680	1.38	(35)	1.97-4.92	(50 - 125)	2.60-5.55	(66.0 - 141.0)	1.97	(50)	3.94-9.84	(100 - 250)
3480	1.77	(45)	2.95-6.89	(75 - 175)	3.74-7.68	(95.0 - 195.0)	2.52	(64)	4.92-11.81	(125 - 300)

Energy Chain System® E2 Tubes Assembly Instructions

Energy Chains® - Assembling E2 Series R100 Energy Tubes

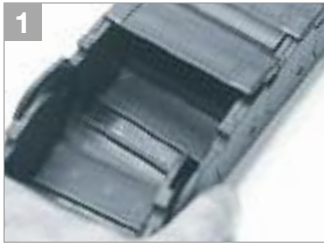

1 Push, click - and snap in pin



2 Swivel lids - push and snap

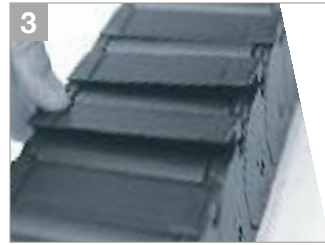

3 Slide last lid



4 Push and snap

Energy Chains® - Separating E2 Series R100 Energy Tubes



1 Lever open lid



2 Bend Energy Tube to remove lid



1 Release side-link



2 Twist and pull apart

Energy Chains® - Opening and Closing E2 Series R1000 Energy Tubes



1 Open: sivel lids



2 Close: push and snap



3 Insert screwdriver into the slot, using a lever action apply pressure to the screwdriver to release



4 Remove lid

Energy Chains® - Separating E2 Series R1000 Energy Tubes



1 Release side link



2 Twist and pull apart

Price Index



Series R07

Special Features / Options



Upon request: Cleanroom Class 1 (ISO class 3) tested by the Dryden Engineering Company, CA



ESD classification:
Electrically conductive
ESD/ATEX version upon request



Flammability Class
VDE 0304 IIC UL94 HB



Low-noise

Assembly Tips



"Zipper" fast opening and closing

Usage Guidelines



- If fast installation using zipper lids is required
- If protection against dust and dirt is required
- If quick insertion of cables with preassembled connectors is required



- If opening of the link is not necessary
➤ **Series 06 E2 Micro**
- If cable installation without opening lids is possible
➤ **Series E06 E-Z Chain**

Features & Benefits

- 1 "Zipper" fast opening and closing
- 2 Small pitch for low-noise, smooth operation
- 3 Zipper lids can be separated and joined at each link
- 4 For high acceleration
- 5 Mounting bracket with integrated strain relief
- 6 Lightweight
- 7 Smallest zip-open Energy Tube
- 8 Protection against dirt and chips



Order Example: Complete Energy Chain®

Please indicate chain length or number of links. Example:

energy chain® configurator

3.28 ft (1 m) **R07-20-038-0**



Energy Chain®

1 Set **060-20-12PZ**



Mounting Bracket

Energy Chain System® E2 Tubes Series R07 Installation Dimensions

energy chain® configurator



R07

Short travel, unsupported length

- FL_B = unsupported with permitted sag
 - FL_G = unsupported with straight upper run
- Further information Design, Chapter 1

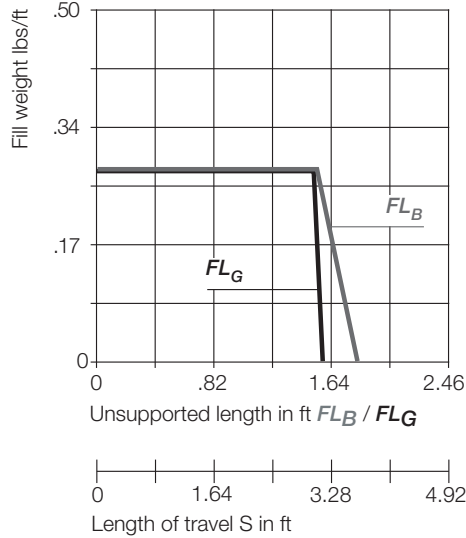
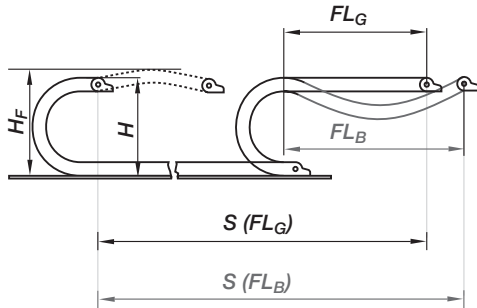

Short Travels - Unsupported



Unsupported Energy Chains® feature positive camber over short travels. This must be accounted for when specifying the clearance height. Please refer to **Installation dimensions** for further details.

Legend

- S = Length of travel
- R = Bending radius
- H = Nominal clearance height
- D = Overlength Energy Chain® radius in final position
- $K = \pi \cdot R + \text{Safety buffer}$
- $H_F = \text{Required clearance height}$

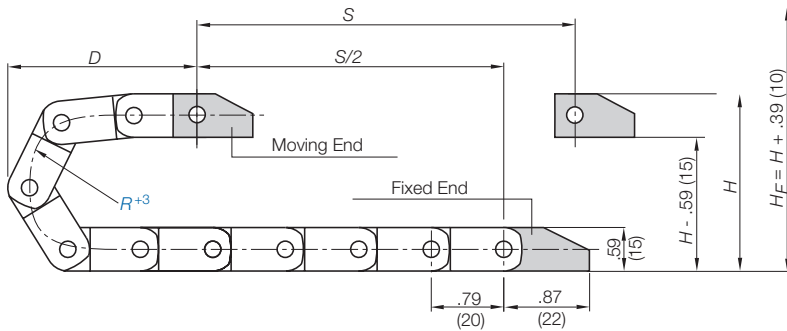

Pitch per link = .79" (20 mm)
Links per ft (m) = 15.24 (50)
For center mount applications:
Chain length = $S/2 + K$

The required clearance height: $H_F = H + .39 \text{ in. (10 mm)}$ (with .13 lbs/ft (0.2 kg/m) fill weight). Please consult igus® if space is particularly restricted.

R	1.50 (038)	1.89 (048)
H	3.58 (91)	4.37 (111)
D	2.99 (76)	3.39 (86)
K	6.30 (160)	7.68 (195)



PDF: www.igus.com/e-chain-pdfs
Specs/CAD/RFQ: www.igus.com/e-chains
RoHS info: www.igus.com/RoHS



Speed / acceleration FL_G	max. 65.6 ft/s (20 m/s) / max. 656 ft/s ² (200 m/s ²)
Speed / acceleration FL_B	max. 9.84 ft/s (3 m/s) / max. 19.69 ft/s ² (6 m/s ²)
Gliding speed / acceleration (maximum)	max. 9.84 ft/s (3 m/s) / max. 32.8 ft/s ² (10 m/s ²)
Material - permitted temperature	igumid G / -40°F (-40°C) up to +248°F (+120° C)
Flammability Class, igumid G	VDE 0304 IIC UL94 HB

Technical Data



Details of material properties

Chapter 1

Series R07 - Energy Tube zip open along the outer radius

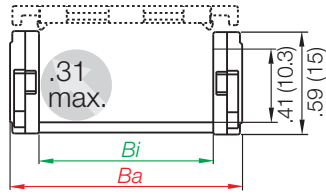

Part Number Structure



- Color - Black
- Bending radius
- Width
- Series

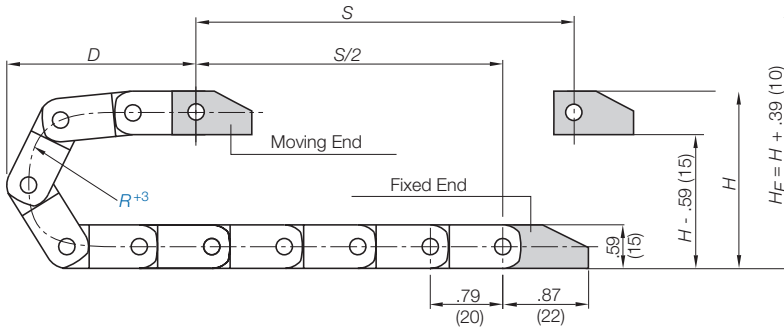

Supplement part number with required radius. Example: R07-20-038-0
Pitch: .79 in. (20 mm) per link links/ft (m) = 15.24 (50)

Part Number	Bi in. (mm)	Ba in. (mm)	Weight lbs/ft (kg/m)
R07-10- <input type="text"/> -0	.39 (10)	.65 (16.5)	≈ 0.09 (0.14)
R07-16- <input type="text"/> -0	.63 (16)	.89 (22.5)	≈ 0.11 (0.16)
R07-20- <input type="text"/> -0	.79 (20)	1.06 (27.0)	≈ 0.11 (0.17)
R07-30- <input type="text"/> -0	1.18 (30)	1.46 (37.0)	≈ 0.13 (0.20)
R07-40- <input type="text"/> -0	1.57 (40)	1.85 (47.0)	≈ 0.15 (0.23)
R07-50- <input type="text"/> -0	1.97 (50)	2.24 (57.0)	≈ 0.17 (0.26)

Choose from the radii below for all of the above sizes

Radius (mm) Example: R07-20-038-0

	038	048
R	1.50 (038)	1.89 (048)
H	3.58 (91)	4.37 (111)
D	2.99 (76)	3.39 (86)
K	6.30 (160)	7.68 (195)

Energy Chain System® E2 Tubes Series R07 Mounting Brackets - Plastic

energy chain® configurator ▶



R07



Plastic, one-piece

- One-piece mounting bracket
- Corrosion resistant
- Available preassembled
- Inner and outer attachment possible
- Available with or without strain relief tie-wrap plates

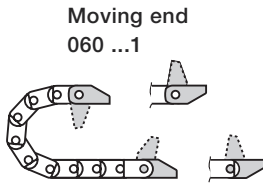

Moving end
060 ...1



Fixed end
060...2

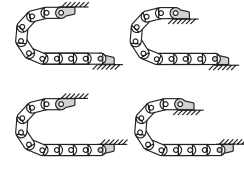

Possible installation configurations -

Part Number Structure

060- 10- 12 PZ

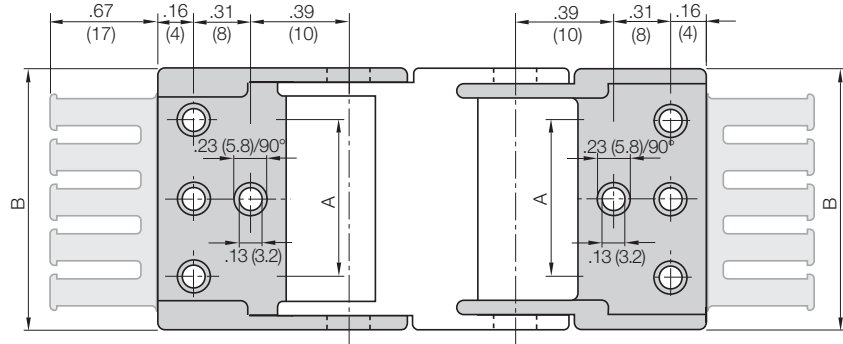
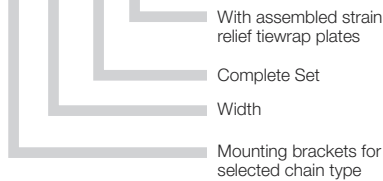

Full set, for both ends:

060- [10- 12] Full set, each part with pin/bore

Single-part order:

060- [10- 1] Mounting bracket with bore

060- [10- 2] Mounting bracket with pin

060-10-12 - 060-20-12:

Center bores only

060-30-12 - 060-50-12:

Outer bores only

Chain Type	Part No.	Part No.	Dimension A		Dimensions B		Number of Teeth
	Full set with Tie-wrap Plate	Full Set without Tie-wrap Plate	in.	(mm)	in.	(mm)	
R07-10	060-10-12PZ	060-10-12	—	—	.65	(16.5)	1
R07-16	060-16-12PZ	060-16-12	—	—	.89	(22.5)	2
R07-20	060-20-12PZ	060-20-12	—	—	1.06	(27.0)	2
R07-30	060-30-12PZ	060-30-12	.87	(22)	1.46	(37.0)	3
R07-40	060-40-12PZ	060-40-12	1.26	(32)	1.85	(47.0)	4
R07-50	060-50-12PZ	060-50-12	1.65	(42)	2.24	(57.0)	5

Additional Accessories



Quicksnap - the complete, detachable mounting unit, upon request



Quickfix - mounting bracket with dowel, upon request

PDF: www.igus.com/e-chain-pdfs
Specs/CAD/RFQ: www.igus.com/e-chains
RoHS info: www.igus.com/RoHS



Price Index

Series R09

Special Features / Options

Upon request: Cleanroom Class 1
(ISO class 3) tested by the Dryden
Engineering Company, CA



iF-Design Award Winner



Flammability Class
VDE 0304 IIC UL94 HB



Low-noise

Assembly Tips

"Zipper" fast opening and closing

Usage Guidelines



- If fast installation using zipper lids is required
- If protection against dust and dirt is required
- If quick insertion of cables with preassembled connectors is required



- If opening of the link is not necessary
➤ **Series 08 E2 Micro**
- If cable installation without opening lids is necessary
➤ **Series E08 E-Z Chain**

Features & Benefits

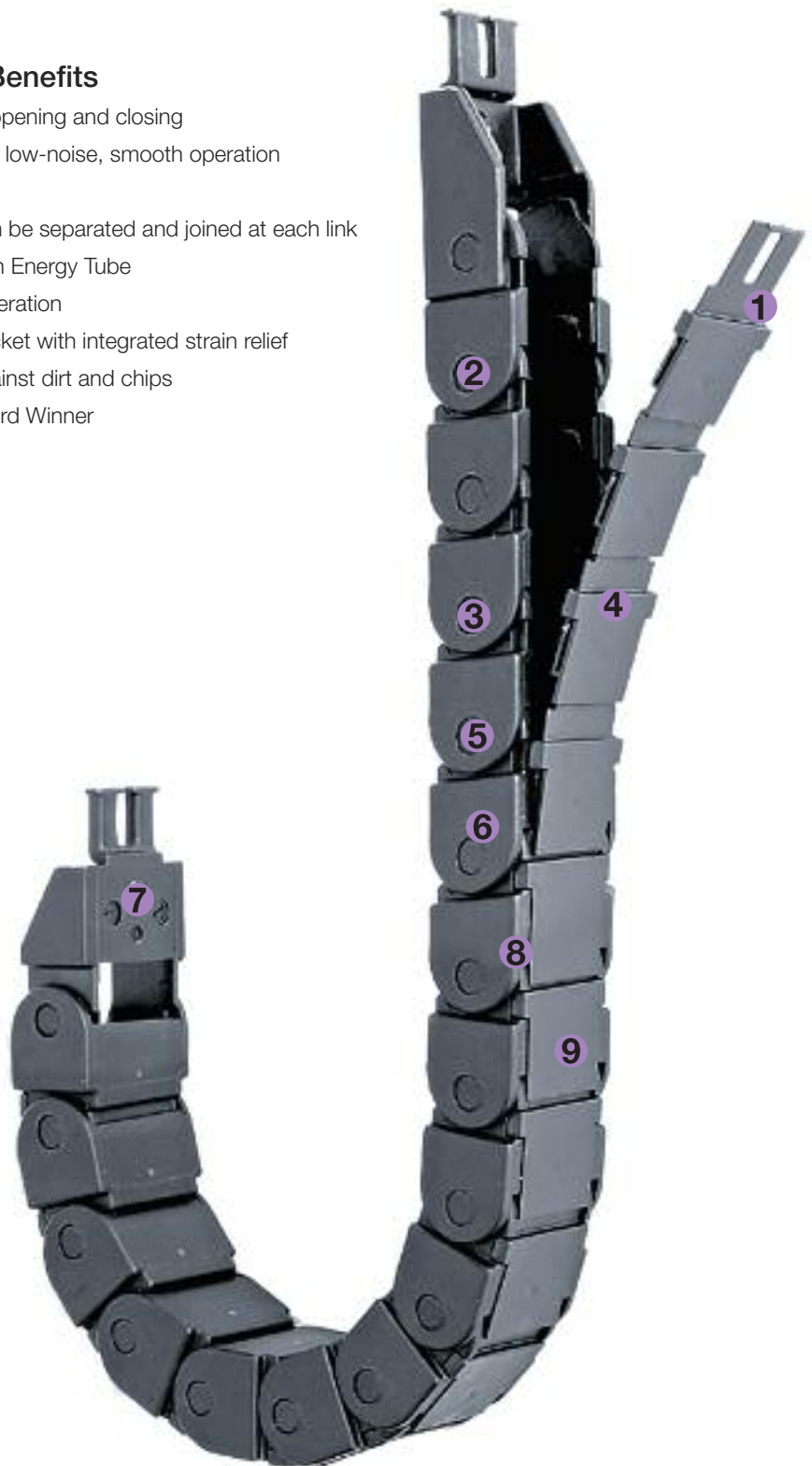
- 1 "Zipper" fast opening and closing
- 2 Small pitch for low-noise, smooth operation
- 3 Lightweight
- 4 Zipper lids can be separated and joined at each link
- 5 Small zip-open Energy Tube
- 6 For high acceleration
- 7 Mounting bracket with integrated strain relief
- 8 Protection against dirt and chips
- 9 iF-Design Award Winner

[energy chain® configurator](#)
Order Example: Complete Energy Chain®

Please indicate chain length or number of links. Example:

3.28 ft (1 m) **R09-20-048-0****Energy Chain®**1 Set **080-20-12PZ****Mounting Bracket**

Energy Chain System® E2 Tubes Series R09 Installation Dimensions

energy chain® configurator ▶



R09

Short travel, unsupported length

- FL_B = unsupported with permitted sag
 - FL_G = unsupported with straight upper run
- Further information ▶ Design, Chapter 1

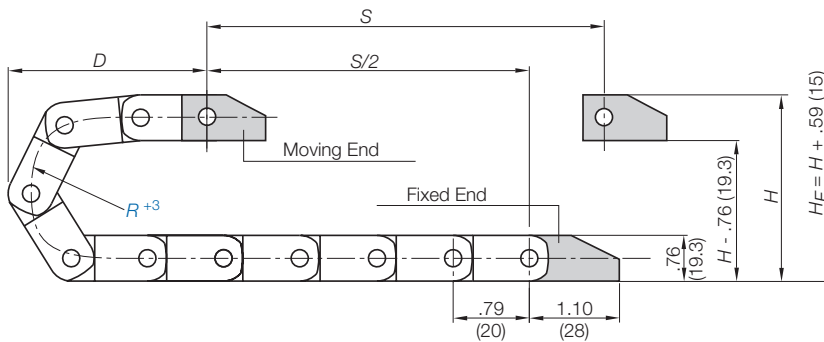
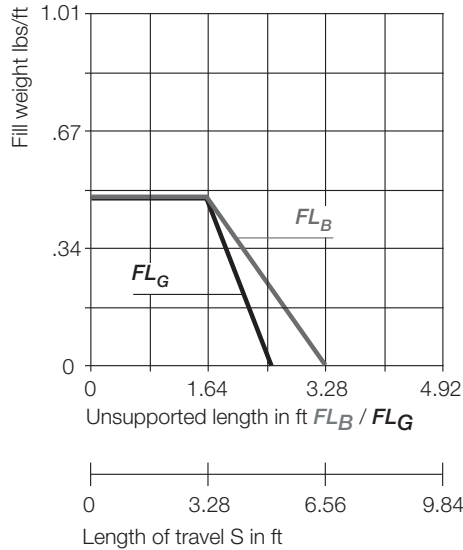
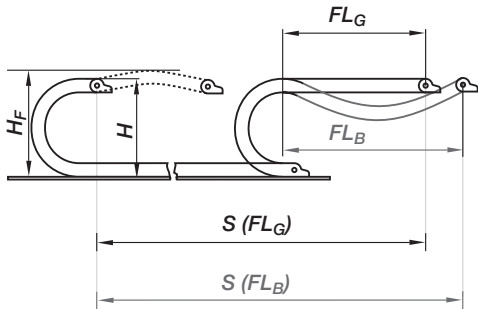

Pitch per link = .79" (20 mm)
Links per ft (m) = 15.24 (50)
For center mount applications:
Chain length = $\frac{S}{2} + K$

The required clearance height: $H_F = H + .59$ in. (15 mm) (with .20 lbs/ft (0.3 kg/m) fill weight).
Please consult igus® if space is particularly restricted.

R	1.89 (048)	2.95 (075)	3.94 (100)
H	4.53 (115)	6.65 (169)	8.62 (219)
D	3.46 (88)	4.53 (115)	5.51 (140)
K	7.68 (195)	11.02 (280)	13.98 (355)

Short Travels - Unsupported



Unsupported Energy Chains® feature positive camber over short travels. This must be accounted for when specifying the clearance height. Please refer to **Installation dimensions** for further details.

Legend

- S = Length of travel
- R = Bending radius
- H = Nominal clearance height
- D = Overlength Energy Chain® radius in final position
- $K = \pi \cdot R + \text{Safety buffer}$
- H_F = Required clearance height



PDF: www.igus.com/e-chain-pdfs
Specs/CAD/RFQ: www.igus.com/e-chains
RoHS info: www.igus.com/RoHS



Speed / acceleration FL_G	max. 65.6 ft/s (20 m/s) / max. 656 ft/s ² (200 m/s ²)
Speed / acceleration FL_B	max. 9.84 ft/s (3 m/s) / max. 19.69 ft/s ² (6 m/s ²)
Gliding speed / acceleration (maximum)	max. 32.8 ft/s (10 m/s) / max. 164 ft/s ² (50 m/s ²)
Material - permitted temperature	igumid G / -40°F (-40°C) up to +248°F (+120°C)
Flammability Class, igumid G	VDE 0304 IIC UL94 HB

Technical Data



Details of material properties

▶ Chapter 1

Series R09 - Energy Tube zip open along the outer radius

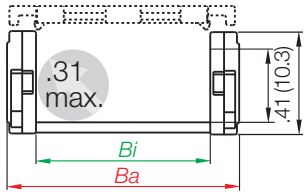

Part Number Structure



- Color - Black
- Bending radius
- Width
- Series

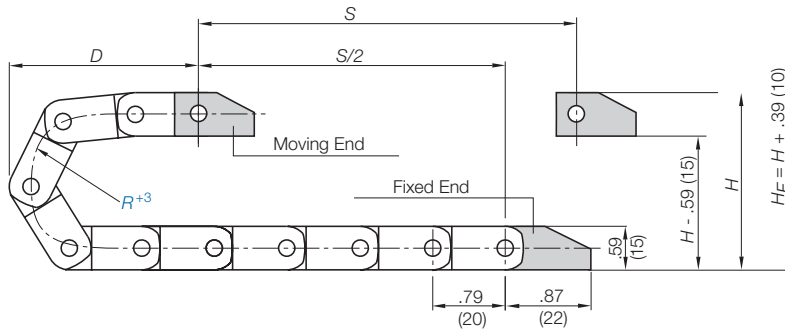

Supplement part number with required radius. Example: R09-20-048-0

Pitch: .79 in. (20 mm) per link links/ft (m) = 15.24 (50)

Part Number	<i>Bi</i> in. (mm)	<i>Ba</i> in. (mm)	Weight lbs/ft (kg/m)
R09-10- <input type="text"/> -0	.39 (10)	.72 (18.2)	≈0.15 (0.23)
R09-16- <input type="text"/> -0	.63 (16)	.95 (24.2)	≈0.17 (0.26)
R09-20- <input type="text"/> -0	.79 (20)	1.11 (28.2)	≈0.18 (0.27)
R09-30- <input type="text"/> -0	1.18 (30)	1.50 (38.2)	≈0.20 (0.30)
R09-40- <input type="text"/> -0	1.57 (40)	1.90 (48.2)	≈0.22 (0.33)
R09-50- <input type="text"/> -0	1.97 (50)	2.29 (58.2)	≈0.24 (0.36)

Choose from the radii below for all of the above sizes

Radius (mm) Example: R09-20-038-0

	048	075	100
<i>R</i>	1.89 (048)	2.95 (075)	3.94 (100)
<i>H</i>	4.53 (115)	6.65 (169)	8.62 (219)
<i>D</i>	3.46 (88)	4.53 (115)	5.51 (140)
<i>K</i>	7.68 (195)	11.02 (280)	13.98 (355)

Energy Chain System® E2 Tubes Series R09 Mounting Brackets - Plastic

energy chain® configurator ▶



R09



Plastic, one-piece

- One-piece mounting bracket
- Corrosion resistant
- Available preassembled
- Inner and outer attachment possible
- Available with or without strain relief tiewrap plates

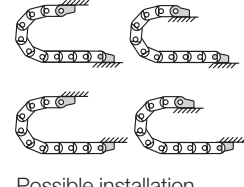
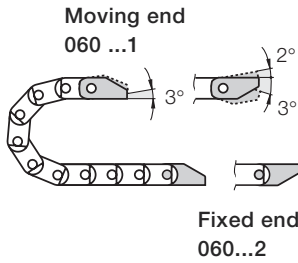

Possible installation configurations -

Part Number Structure

080-	20-	12	PZ
------	-----	----	----

- With assembled strain relief tiewrap plates
- Complete Set
- Width
- Mounting brackets for selected chain type

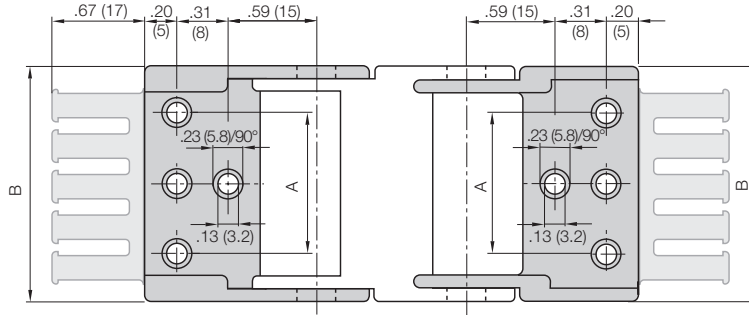

Full set, for both ends:

080- [20- 12] Full set, each part with pin/bore

Single-part order:

080- [20- 1] Mounting bracket with bore

080- [20- 2] Mounting bracket with pin

080-10-12 - 080-20-12:

Center bores only

080-30-12 - 080-50-12:

Outer bores only

Chain Type	Part No. Full set with Tiewrap Plate	Part No. Full Set without Tiewrap Plate	Dimension A		Dimensions B		Number of Teeth
			in.	(mm)	in.	(mm)	
08-10	080-10-12PZ	080-10-12	—	—	.72	(18.2)	1
08-16	080-16-12PZ	080-16-12	—	—	.95	(24.2)	2
08-20	080-20-12PZ	080-20-12	—	—	1.11	(28.2)	2
08-30	080-30-12PZ	080-30-12	.87	(22)	1.50	(38.2)	3
08-40	080-40-12PZ	080-40-12	1.26	(32)	1.90	(48.2)	4
08-50	080-50-12PZ	080-50-12	1.65	(42)	2.29	(58.2)	5

Additional Accessories



Quicksnap - the complete, detachable mounting unit, upon request



Quickfix - mounting bracket with dowel, upon request

PDF: www.igus.com/e-chain-pdfs
Specs/CAD/RFQ: www.igus.com/e-chains
RoHS info: www.igus.com/RoHS



Price Index

Series R48

Special Features / Options

ESD classification:
Electrically conductive
ESD/ATEX version upon request



Flammability Class
VDE 0304 IIC UL94 HB

Assembly Tips

To open the Energy Tube Series R, lift up the lid (with a screwdriver) and remove the lid

Other Installation Methods

Vertical, hanging ≤ 164 ft (50 m)

Vertical, standing ≤ 13.12 ft (4 m)

Side-mounted, un_supp. ≤ 4.92 ft (1.5 m)

Rotary requires further calculation

Usage Guidelines

- If particularly quiet operation is required
- If very high speeds are required
- If chip repellent features are required



- If a particularly low-cost solution is the main factor
➤ **Series R117/R118 E2 Tubes**
- If no chip protection is required
➤ **Series 250 E2 Medium**

Features & Benefits

- 1 Large pins for high stability
- 2 Protection for cables and hoses against hot chips
- 3 Removable lids along the outer radius
- 4 Small pitch for low-noise, smooth operation
- 5 KMA mounting brackets with attachment capabilities on all sides
- 6 Smooth, chip-repellent exterior
- 7 Fully enclosed
- 8 Strain relief separator option: Separator with integrated strain relief for use in the first or last chain link ➤ **Strain Relief, Chapter 10**

Order Example: Complete Energy Chain®

Please indicate chain length or number of links. Example:

energy chain® configurator

3.28 ft (1 m) **48-075-060-0**

Energy Chain®

With 2 separators **482** assembled every 2nd link

Interior Separation

1 Set **480-075-12**

Mounting Bracket

Energy Chain System® E2 Tubes Series R48 Installation Dimensions

energy chain® configurator ▶



R48

Short travel, unsupported length

- FL_B = unsupported with permitted sag
 - FL_G = unsupported with straight upper run
- Further information ▶ Design, Chapter 1

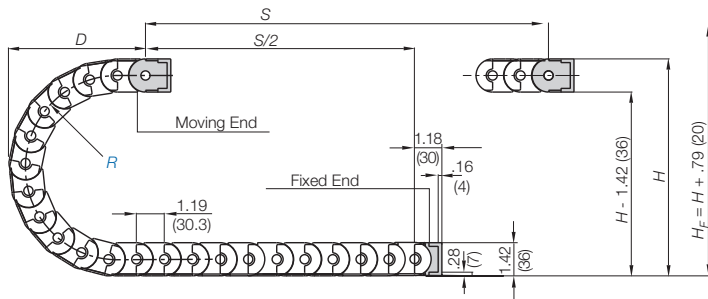
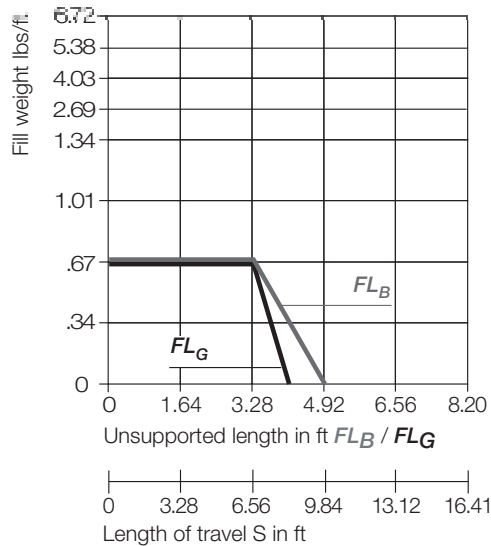
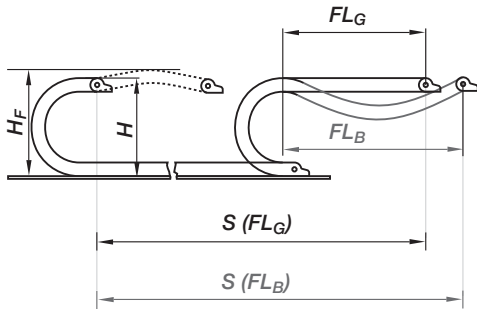

Pitch per link = 1.19" (30.3 mm)
Links per ft (m) = 10.06 (33)
For center mount applications:
Chain length = $S/2 + K$

The required clearance height: $H_F = H + .79$ in. (20 mm) (with .34 lbs/ft (0.5 kg/m) fill weight). Please consult igus® if space is particularly restricted.

R	2.36 (060)	2.95 (075)	3.94 (100)	4.92 (125)	5.91 (150)	6.89 (175)	7.87 (200)	9.84 (250)
H	6.14 (156)	7.32 (186)	9.29 (236)	11.26 (286)	13.23 (336)	15.20 (386)	17.17 (436)	21.10 (536)
D	4.84 (123)	5.43 (138)	6.42 (163)	7.40 (188)	8.39 (213)	9.37 (238)	10.35 (263)	12.32 (313)
K	9.84 (250)	11.81 (300)	14.76 (375)	17.91 (455)	21.06 (535)	24.21 (615)	27.17 (690)	33.46 (850)

Short Travels - Unsupported



Unsupported Energy Chains® feature positive camber over short travels. This must be accounted for when specifying the clearance height. Please refer to **Installation dimensions** for further details.

Legend

- S = Length of travel
 - R = Bending radius
 - H = Nominal clearance height
 - D = Overlength Energy Chain® radius in final position
 - $K = \pi \cdot R + \text{safety buffer}$
 - H_F = Required clearance height
 - H_{R1} = Trough inner height
 - H_2 = *Mounting height
 - D_2 = Over length - long travels, gliding
 - K_2 = *Add-on
- *If the mounting bracket location is set lower



PDF: www.igus.com/e-chain-pdfs
Specs/CAD/RFQ: www.igus.com/e-chains
RoHS info: www.igus.com/RoHS



Speed / acceleration FL_G	max. 32.8 ft/s (10 m/s) / max. 328 ft/s ² (100 m/s ²)
Speed / acceleration FL_B	max. 9.84 ft/s (3 m/s) / max. 19.69 ft/s ² (6 m/s ²)
Gliding speed / acceleration (maximum)	max. 9.84 ft/s (3 m/s) / max. 32.8 ft/s ² (10 m/s ²)
Material - permitted temperature	igumid G / -40°F (-40°C) up to +248°F (+120°C)
Flammability Class, igumid G	VDE 0304 IIC UL94 HB

Technical Data



Details of material properties

▶ Chapter 1

Series R48 - Energy Tube snap-open along the outer radius

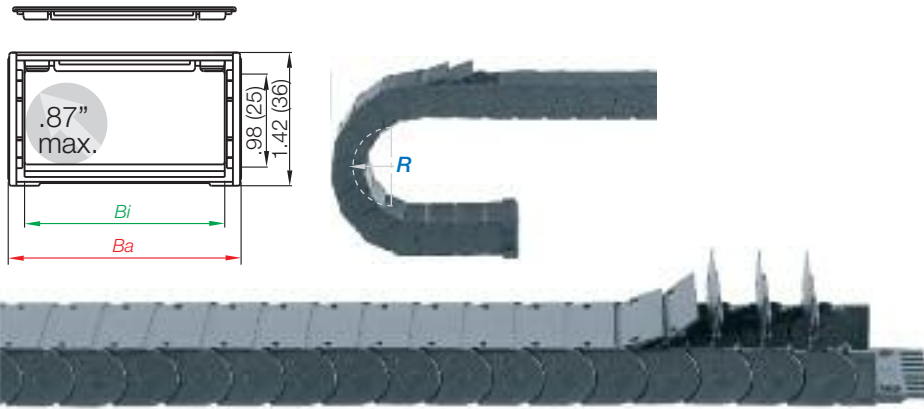

Part Number Structure

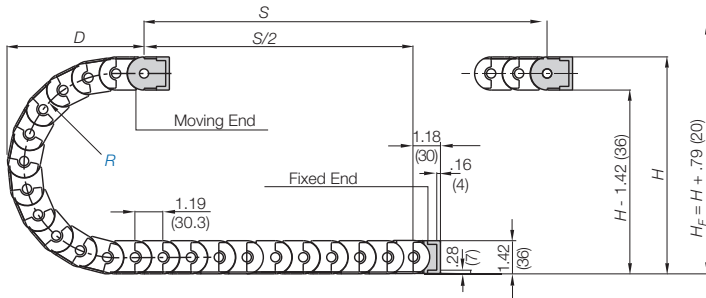
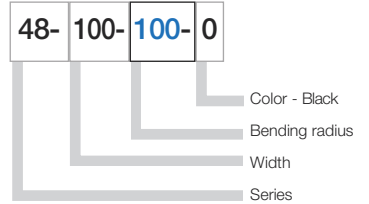

Supplement part number with required radius. Example: R48-100-**100**-0
Pitch: 1.19 in. (30.3 mm) per link links/ft (m) = 10.06 (33)

Part Number	<i>Bi</i> in. (mm)	<i>Ba</i> in. (mm)	Weight lbs/ft (kg/m)
48-025- <input type="checkbox"/> -0	.98 (25)	1.42 (36)	≈ 0.43 (0.64)
48-050- <input type="checkbox"/> -0	1.97 (50)	2.40 (61)	≈ 0.56 (0.84)
48-075- <input type="checkbox"/> -0	2.95 (75)	3.39 (86)	≈ 0.69 (1.03)
48-100- <input type="checkbox"/> -0	3.94 (100)	4.37 (111)	≈ 0.83 (1.23)
48-130- <input type="checkbox"/> -0	5.12 (130)	5.55 (141)	≈ 0.98 (1.46)

Choose from the radii below for all of the above sizes

Radius (mm) Example: R48-100-**100**-0

	060	075	100	125	150	175	200	250
R	2.36 (060)	2.95 (075)	3.94 (100)	4.92 (125)	5.91 (150)	6.89 (175)	7.87 (200)	9.84 (250)
H	6.14 (156)	7.32 (186)	9.29 (236)	11.26 (286)	13.23 (336)	15.20 (386)	17.17 (436)	21.10 (536)
D	4.84 (123)	5.43 (138)	6.42 (163)	7.40 (188)	8.39 (213)	9.37 (238)	10.35 (263)	12.32 (313)
K	9.84 (250)	11.81 (300)	14.76 (375)	17.91 (455)	21.06 (535)	24.21 (615)	27.17 (690)	33.46 (850)

Interior Separation

Option 1: Vertical separators and spacers

Vertical separators are used if a vertical subdivision of the Energy Chain® interior is required. By standard, vertical separators are assembled every other Energy Chain® link. .

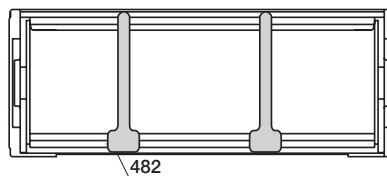

Vertical separator
481

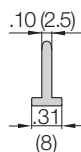

Vertical Separator

Unassembled	Part No. 481
Assembled	Part No. 482

- Standard separator 481 for Energy Chains®
This separator is used for general subdivision of Energy Chain®.

Energy Chain System® E2 Tubes Series R48 Mounting Brackets - KMA

energy chain® configurator ▶



R48

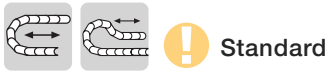

Option 1: KMA pivoting

- Attachment points on all sides
- Corrosion resistant

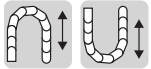
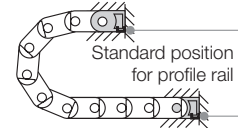
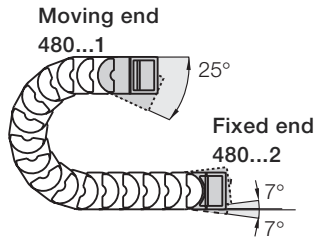

Option 2: KMA locking

- Vertical hanging, standing travel
- Attachment points on all sides
- Corrosion resistant

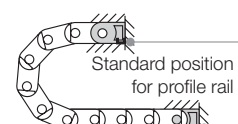
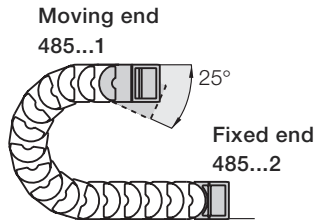

Part Number Structure

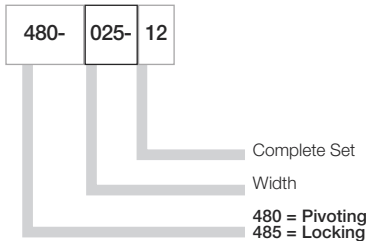

Full set, for both ends:

480-025-12 Full set, each part with pin/bore

Single-part order:

480-025-1 Mounting bracket with bore

480-025-2 Mounting bracket with pin

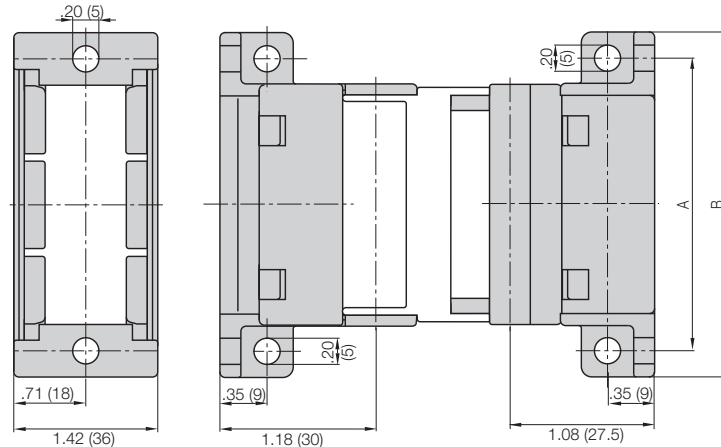

Width	Part No. Full Set		Dimension A		Dimension B	
	Pivoting	Locking	in.	(mm)	in.	(mm)
-025	480	485	1.77	(45)	2.17	(55)
-050	480	485	2.76	(70)	3.15	(80)
-075	480	485	3.74	(95)	4.13	(105)
-100	480	485	4.72	(120)	5.12	(130)
-130	480	485	5.91	(150)	6.30	(160)

The following parts are required for attachment of the mounting brackets:

- Socket head cap bolt M5* DIN 912-8.8
4 pieces/set
- Washer 5.3 DIN 125-ST
8 pieces/set
- Hexagon nut M5 DIN 934-8
4 pieces/set

* The length of the socket head cap bolt is dependent on the thickness of the attachment base.

PDF: www.igus.com/e-chain-pdfs
Specs/CAD/RFQ: www.igus.com/e-chains
RoHS info: www.igus.com/RoHS



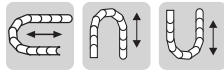

Option 1: Steel

- Locked connection to Energy Tube
- Electrically conductive
- Minimized external width

Moving end
482...1

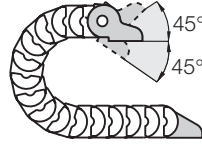

Fixed end
482...2

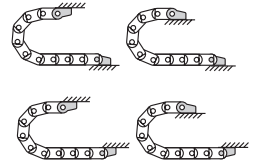

Possible installation configurations -

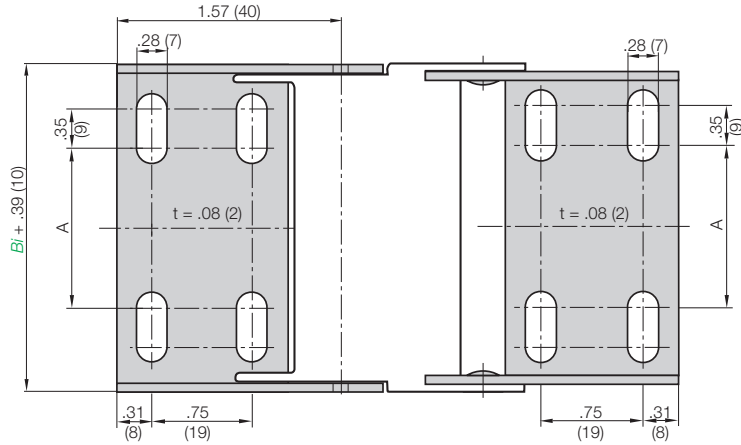

Full set, for both ends:

482- 025- 12 Full set, each part with pin/bore

Single-part order:

482- 025- 1 Mounting bracket with bore

482- 025- 2 Mounting bracket with pin

For Series	Part No. Full Set	Dimension A in. (mm)
------------	----------------------	-------------------------

48-025	482-025-12	-
48-050	482-050-12	.87 (22)
48-075	482-075-12	1.85 (47)
48-100	482-100-12	2.83 (72)
48-130	482-130-12	4.02 (102)

The following parts are required for attachment of the mounting brackets:

- Socket head cap bolt M5* DIN 912-8.8
4 pieces/set
- Washer 5.3 DIN 125-ST
8 pieces/set
- Hexagon nut M5 DIN 934-8
4 pieces/set

* The length of the socket head cap bolt is dependent on the thickness of the attachment base.

Part No. Mounting Brackets Full Set

4 parts, 2 with pin, 2 with bore

Series R48:

482-Width-12

Part No. Mounting bracket with bore

2 parts, 1 left & 1 right

Series R48:

482-Width -1

Part No. Mounting bracket with pin

2 parts, 1 left & 1 right

Series R48:

482-Width-2

Energy Chain System® E2 Tubes Series R48 Mounting Bracket - Plastic

energy chain® configurator



R48



Option 1: Plastic

- Attachment option for strain relief tie-wrap plate
- Locked connection to Energy Tube
- Minimized external width

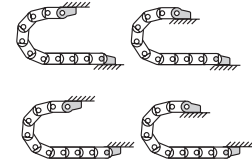
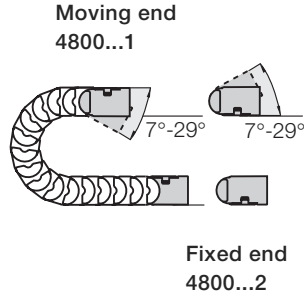

Possible installation configurations -

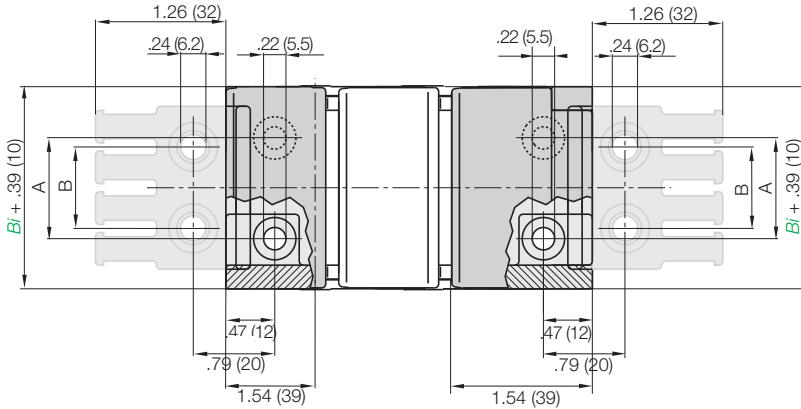

Part Number Structure

4800- 025- 12- PZB

- 4800- With tie-wrap plate
- 025- Complete Set
- 12- Width
- PZB Mounting brackets for selected chain type

Full set, for both ends:

4800-025-12 Full set, each part with pin/bore

Single-part order:

- 4800-025-1 Mounting bracket with bore
- 4800-025-2 Mounting bracket with pin

Part No. Mounting Brackets Full Set

4 parts, 2 with pin, 2 with bore
Series R48:
4800-Width-12

Part No. Mounting bracket with bore

2 parts, 1 left & 1 right
Series R48:
4800-Width -1

Part No. Mounting bracket with pin

2 parts, 1 left & 1 right
Series R48:
4800-Width-2

For Series	Part No. Full Set	Part No. Full Set with Tiewrap Plate	Dimension A		Dimension B	
			in.	(mm)	in.	(mm)
48-025	4800-025-12	4800-025-12PZB	.47	(12)	.59	(15)
48-050	4800-050-12	4800-050-12PZB	1.46	(37)	1.18	(30)
48-075	4800-075-12	4800-075-12PZB	2.44	(62)	1.57	(40)
48-100	4800-100-12	4800-100-12PZB	3.43	(87)	3.15	(80)
48-130	4800-130-12	4800-130-12PZB	4.61	(117)	-	-

The following parts are required for attachment of the mounting brackets:

- Socket head cap bolt M5* DIN 912-8.8
4 pieces/set
- Washer 5.3 DIN 125-ST
8 pieces/set
- Hexagon nut M5 DIN 934-8
4 pieces/set

* The length of the socket head cap bolt is dependent on the thickness of the attachment base.

PDF: www.igus.com/e-chain-pdfs
Specs/CAD/RFQ: www.igus.com/e-chains
RoHS info: www.igus.com/RoHS

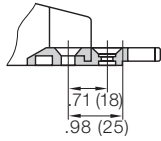
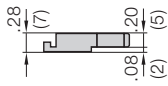

Tiewrap Plates

 Shown
assembled

 Single
tiewrap
plate

**Option 1:
Tiewrap plates as an individual part**

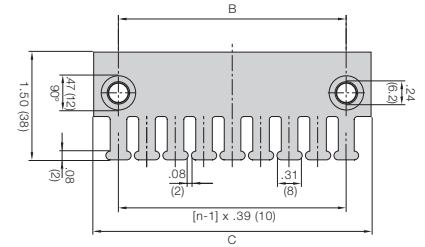
Available as an individual component that can be fixed external to the mounting bracket.

Tiewrap Plates	n Number of Teeth	Dimension C	Dimension B
2020-ZB	3	1.18 (30)	.59 (15)
2030-ZB	4	1.57 (40)	.79 (20)
2040-ZB	5	1.97 (50)	1.18 (30)
2050-ZB	6	2.36 (60)	1.57 (40)
2070-ZB	8	3.15 (80)	2.36 (60)
2090-ZB	9	3.54 (90)	2.76 (70)
2100-ZB	10	3.94 (100)	3.15 (80)
2120-ZB	12	4.72 (120)	3.94 (100)

 For more information please refer to
strain relief section of Chapter 10

Cable tiewraps as individual parts

Cable tiewraps 100 pieces/bag	Width x Length		Maximum Ø		Tensile Strength	
	in.	(mm)	in.	(mm)	lbs	(N)
CFB-001	.19 x 5.91	(4.8 x 150)	1.42	(36)	50	(222)

PDF: www.igus.com/e-chain-pdfs
Specs/CAD/RFQ: www.igus.com/e-chains
RoHS info: www.igus.com/RoHS



Price Index

Series R58

Special Features / Options

ESD classification:
Electrically conductive
ESD/ATEX version upon request



Flammability Class
VDE 0304 IIC UL94 HB

Assembly Tips

To open the Energy Tube Series R, lift up the lid (with a screwdriver) and remove the lid

Other Installation Methods

Vertical, hanging ≤ 164 ft (50 m)

Vertical, standing ≤ 13.12 ft (4 m)

Side-mounted, un supp. ≤ 6.56 ft (2 m)

Rotary requires further calculation

Usage Guidelines

- If particularly quiet operation is required
- If very high speeds are required
- If chip protection is subject to stringent requirements



- If a particularly low-cost solution is the main factor
➤ **Series R157/R158 E2 Tubes**
- If no chip protection is required
➤ **Series 250 E2 Medium**

Features & Benefits

- 1 Protection for cables and hoses against hot chips
- 2 Large pins for high stability
- 3 Removable lids along the outer radius
- 4 Small pitch for low-noise, smooth operation
- 5 KMA mounting brackets with attachment capabilities on all sides
- 6 Smooth, chip-repellent exterior
- 7 Fully enclosed
- 8 Small pitch enable very small radii
- 9 Integrated strain relief available especially for Energy Tubes

Order Example: Complete Energy Chain®

Please indicate chain length or number of links. Example:

energy chain® configurator

3.28 ft (1 m) **58-100-100-0**



Energy Chain®

With 2 separators **582** assembled every 2nd link



Interior Separation

1 Set **580-100-12**



Mounting Bracket

Energy Chain System® E2 Tubes Series R58 Installation Dimensions

energy chain® configurator ▶



R58

Short travel, unsupported length

- FL_B = unsupported with permitted sag
 - FL_G = unsupported with straight upper run
- Further information ▶ Design, Chapter 1

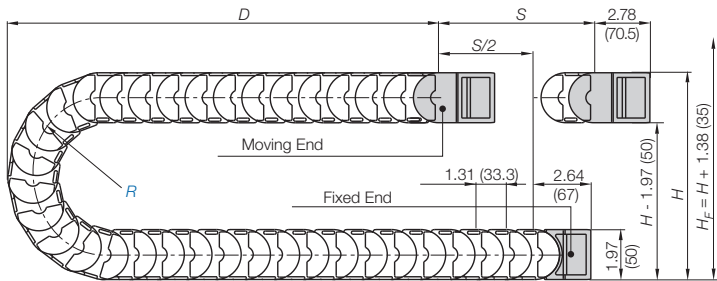
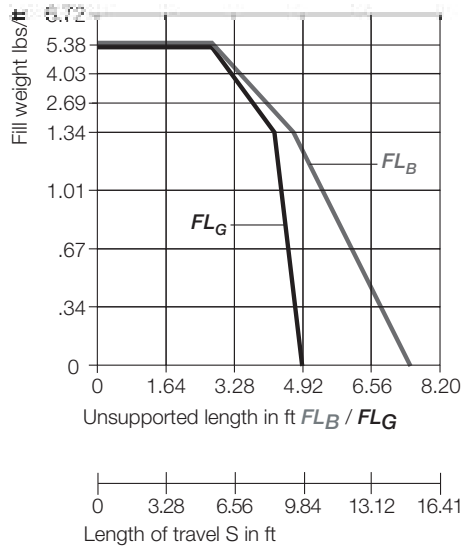
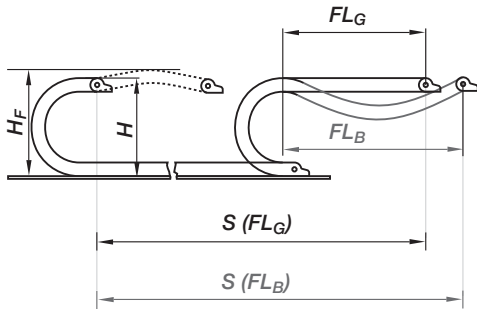

Pitch per link = 1.31" (33.3 mm)
Links per foot (m) = 9.14 (30)
For center mount applications:
Chain length = $S/2 + K$

The required clearance height: $H_f = H + 1.38$ in. (35 mm) (with .34 lbs/ft (0.5 kg/m) fill weight). Please consult igus® if space is particularly restricted.

R	2.95 (075)	3.94 (100)	4.92 (125)	5.91 (150)	7.87 (200)	9.84 (250)
H	7.87 (200)	9.84 (250)	11.81 (300)	13.78 (350)	17.72 (450)	21.65 (550)
D	5.91 (150)	6.89 (175)	7.87 (200)	8.86 (225)	10.83 (275)	12.80 (325)
K	12.96 (305)	15.16 (385)	18.11 (460)	21.26 (540)	27.36 (695)	33.66 (855)

For long travels with lowered mounting height

Long travel lengths from 32.8 ft. (10 m) to max. 246 ft. (75 m)

For center mount applications:
Chain length = $S/2 + K_2$

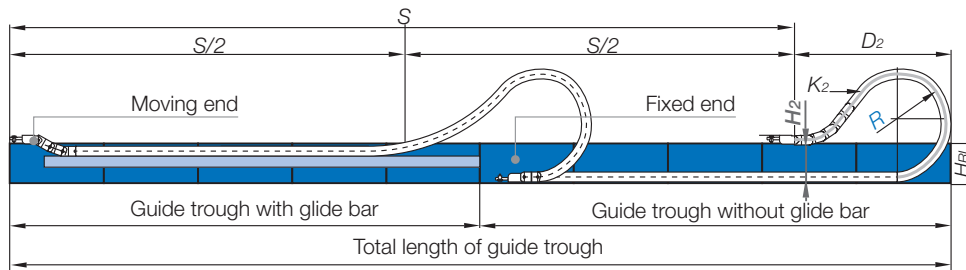

R	2.95 (075)	3.94 (100)	4.92 (125)	5.91 (150)	7.87 (200)	9.84 (250)
H_2	7.87 (200)	8.50 (216)	8.50 (216)	8.50 (216)	8.50 (216)	8.50 (216)
D_2	5.91 (150)	12.20 (310)	14.96 (380)	18.90 (480)	31.50 (800)	41.34 (1050)
K_2	14.76 (375)	19.69 (500)	27.52 (699)	34.09 (866)	49.80 (1265)	65.55 (1665)

Short Travels - Unsupported



Unsupported Energy Chains® feature positive camber over short travels. This must be accounted for when specifying the clearance height. Please refer to **Installation dimensions** for further details.

Legend

- S = Length of travel
 - R = Bending radius
 - H = Nominal clearance height
 - D = Overlength Energy Chain® radius in final position
 - $K = \pi \cdot R + \text{safety buffer}$
 - H_f = Required clearance height
 - H_{R1} = Trough inner height
 - H_2 = *Mounting height
 - D_2 = Overlength - long travels, gliding
 - K_2 = *Add-on
- *If the mounting bracket location is set lower

Long Travels - Gliding



If the unsupported length is exceeded, the Energy Chain®/Tube must glide on itself. This requires a guide trough.

Design, Chapter 1

Technical Data



Details of material properties

▶ Chapter 1

Speed / acceleration FL_G	max. 32.8 ft/s (10 m/s) / max. 328 ft/s ² (100 m/s ²)
Speed / acceleration FL_B	max. 9.84 ft/s (3 m/s) / max. 19.69 ft/s ² (6 m/s ²)
Gliding speed / acceleration (maximum)	max. 9.84 ft/s (3 m/s) / max. 32.8 ft/s ² (10 m/s ²)
Material - permitted temperature	igumid G / -40°F (-40°C) up to +248°F (+120° C)
Flammability Class, igumid G	VDE 0304 IIC UL94 HB

PDF: www.igus.com/e-chain-pdfs
Specs/CAD/RFQ: www.igus.com/e-chains
RoHS info: www.igus.com/RoHS



Series R58 - Energy Tube snap-open along the outer radius

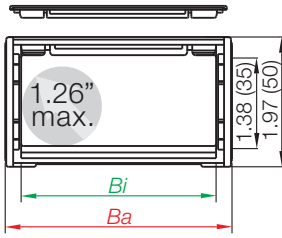

Part Number Structure



- Color - Black
- Bending radius
- Width
- Series

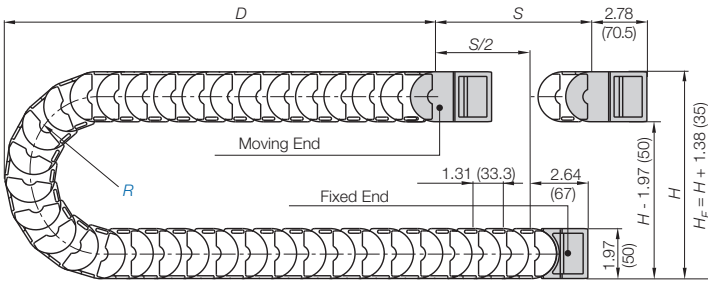

Supplement part number with required radius. Example: R58-100--0
Pitch: 1.31 in. (33.3 mm) per link links/ft (m) = 9.14 (30)

Part Number	<i>Bi</i> in. (mm)	<i>Ba</i> in. (mm)	Weight lbs/ft (kg/m)
58-050- <input type="text" value=""/> -0	1.97 (50)	2.60 (66)	≈ 1.01 (1.50)
58-075- <input type="text" value=""/> -0	2.95 (75)	3.58 (91)	≈ 1.19 (1.77)
58-100- <input type="text" value=""/> -0	3.94 (100)	4.57 (116)	≈ 1.37 (2.04)
58-125- <input type="text" value=""/> -0	4.92 (125)	5.55 (141)	≈ 1.55 (2.31)
58-150- <input type="text" value=""/> -0	5.91 (150)	6.54 (166)	≈ 1.75 (2.61)
58-175- <input type="text" value=""/> -0	6.89 (175)	7.52 (191)	≈ 1.94 (2.88)
58-200- <input type="text" value=""/> -0	7.87 (200)	8.50 (216)	≈ 2.12 (3.15)

Choose from the radii below for all of the above sizes
Radius (mm) Example: R58-100--0

	<input type="text" value="075"/>	<input type="text" value="100"/>	<input type="text" value="125"/>	<input type="text" value="150"/>	<input type="text" value="200"/>	<input type="text" value="250"/>
R	2.95 (75)	3.94 (100)	4.92 (125)	5.91 (150)	7.87 (200)	9.84 (250)
H	7.87 (200)	9.84 (250)	11.81 (300)	13.78 (350)	17.72 (450)	21.65 (550)
D	5.91 (150)	6.89 (175)	7.87 (200)	8.86 (225)	10.83 (275)	12.80 (325)
K	12.96 (305)	15.16 (385)	18.11 (460)	21.26 (540)	27.36 (695)	33.66 (855)

Energy Chain System® E2 Tubes

Series R58

Interior Separation

energy chain® configurator ▶



R58

Option 1: Vertical separators

Vertical separators are used if a vertical subdivision of the Energy Tube interior is required. By standard, vertical separators are assembled every other Energy Tube link.

STANDARD

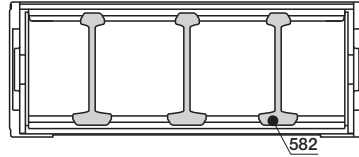

- **Standard separator 581 for Energy Tubes**
This separator is used for general subdivision of Energy Tubes.

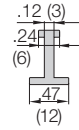

Vertical Separator

Unassembled	Part No. 581
Assembled	Part No. 582

Option 2: Full-width shelf

It is ideal for use in applications involving many thin cables with similar or identical diameters. This shelf slides into place and spans the entire width of the chain.

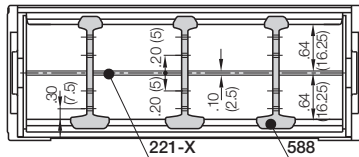

- **Slotted separator 587 for Energy Tubes**
This component is used to form the basic pattern of a shelf system.

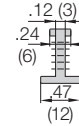

Slotted Separator

Unassembled	Part No. 587
Assembled	Part No. 588

Shelves 220-XX

Shelves can be inserted at 3 different heights in .20" (5mm) increments

Width X in. (mm)	Part No. Unassembled	Part No. Assembled	Width X in. (mm)	Part No. Unassembled	Part No. Assembled
1.97 (50)	220-50	221-50	5.91 (150)	220-150	221-150
2.95 (75)	220-75	221-75	6.89 (175)	220-175	221-175
3.94 (100)	220-100	221-100	7.87 (200)	220-200	221-200
4.92 (125)	220-125	221-125			

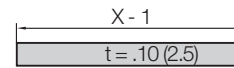

Option 3: Shelves

It is ideal for use in applications involving many cables with similar or identical diameters. Partial separation into individual compartments can be achieved and can be used across the entire width.

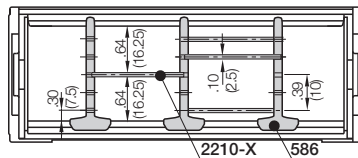

- **Slotted separator 585 for Energy Tubes**
This component is used to form the basic pattern of a shelf system.

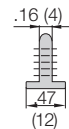

Slotted Separator

Unassembled	Part No. 585
Assembled	Part No. 586

Shelves 2200-XX

These components form the basic pattern of a shelf system. Shelves of various widths can be arranged at 3 different heights in .20" (5mm) increments

Width X in. (mm)	Part No. Unassembled	Part No. Assembled	Width X in. (mm)	Part No. Unassembled	Part No. Assembled
.71 (18)	2200-18	2210-18	2.28 (58)	2200-58	2210-58
.91 (23)	2200-23	2210-23	2.68 (68)	2200-68	2210-68
1.10 (28)	2200-28	2210-28	2.87 (73)	2200-73	2210-73
1.30 (33)	2200-33	2210-33	3.46 (88)	2200-88	2210-88
1.50 (38)	2200-38	2210-38	3.90 (99)	2200-99	2210-99
1.69 (43)	2200-43	2210-43	4.88 (124)	2200-124	2210-124
1.89 (48)	2200-48	2210-48	5.87 (149)	2200-149	2210-149

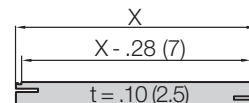

PDF: www.igus.com/e-chain-pdfs
 Specs/CAD/RFQ: www.igus.com/e-chains
 RoHS info: www.igus.com/RoHS



igus® Energy Chain System®

Telephone 1-800-521-2747
Fax 1-401-438-7270

Internet: <http://www.igus.com>
email: sales@igus.com
QuickSpec: <http://www.igus.com/quickspec>

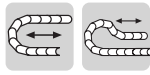

Standard

Option 1: pivoting

- Unsupported and gliding applications
- Space-restricted conditions
- Mounting points on all sides
- KMA with Quickflange option available for short and long travels

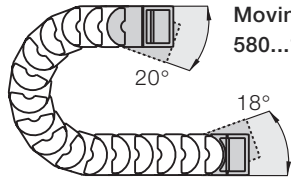

Moving end
580...1

Fixed end
580...2

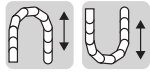
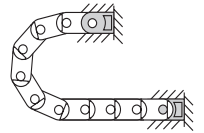

Option 2: locking

- Vertical hanging/standing travels
- Extreme speeds and accelerations
- Mounting points on all sides
- Flush mounting at both ends of the Energy Tube
- KMA with Quickflange option

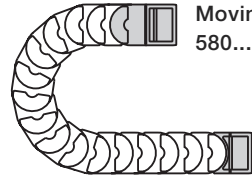

Moving end
580...3

Fixed end
580...4

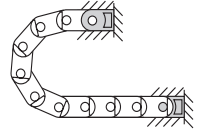

Part Number Structure

580-050-12-QF

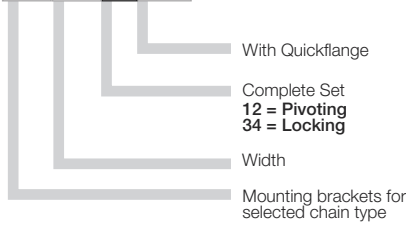

With Quickflange
Complete Set
12 = Pivoting
34 = Locking
Width
Mounting brackets for selected chain type

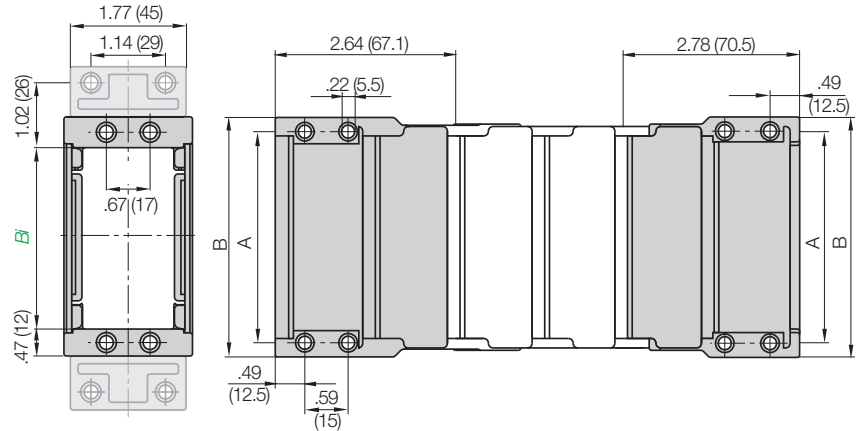

Full set, for both ends:

580-050-12-QF Full set, each part with pin/bore + tiewrap plate

Single-part order:

580-050-1-QF Mounting bracket with bore + tiewrap plate

580-050-2-QF Mounting bracket with pin + tiewrap plate



Quickflange upon request

- Unassembled

Part number 16800-QF

For Tube Type	Part No. Full set with Tiewrap Plate	Part No. Full Set with Quickflange	Dimension A in. (mm)	Dimension B in. (mm)
58-050	580-050-□	580-050-□ QF	2.44 (62)	2.91 (74)
58-075	580-075-□	580-075-□ QF	3.43 (87)	3.90 (99)
58-100	580-100-□	580-100-□ QF	4.41 (112)	4.88 (124)
58-125	580-125-□	580-125-□ QF	5.39 (137)	5.87 (149)
58-150	580-150-□	580-150-□ QF	6.38 (162)	6.85 (174)
58-175	580-175-□	580-175-□ QF	7.36 (187)	7.83 (199)
58-200	580-200-□	580-200-□ QF	8.35 (212)	8.82 (224)

For pivoting brackets choose **12**

For locking brackets choose **34**

Example: 580-050-**34** QF

The following parts are required for attachment of the mounting brackets:

- **Socket head cap bolt**
M5* DIN 912-8.8
8 pieces/set
- **Washer**
5.3 DIN 125-ST
8 pieces/set
- **Hexagon nut**
M5 DIN 934-8
8 pieces/set

* The length of the socket head cap bolt is dependent on the thickness of the attachment base.



Integrated strain relief for E2 Energy Tubes - Series R

- Strain relief disappears completely within the Energy Tube
- Easy to assemble, no screws required

Part. No.	Width (mm)	Number of teeth
5850-Z	1.81 (46)	4

Number of tiewrap plates 5850-Z for selected inner width *Bi*

<i>Bi</i> (mm)	Width tiewrap plate (mm)	Number of tiewrap plate <i>n</i>	Total number of teeth
50	-	-	-
75	1.81 (46)	1	4
100	1.81 (46)	1	4
125	1.81 (46)	2	8
150	1.81 (46)	2	8
175	1.81 (46)	3	12
200	1.81 (46)	3	12

PDF: www.igus.com/e-chain-pdfs
 Specs/CAD/RFQ: www.igus.com/e-chains
 RoHS info: www.igus.com/RoHS



Guide troughs are used with applications where the upper run of the Energy Chain® glides on the lower run. If using igus steel guide troughs, the following components are required:

- Full travel length of guide trough
Part number 95-30
- 1/2 travel length glide bars
Part number 92-01
- Installation sets as end connectors
Part number 95-50-XX

-XX indicates the length of the profile rails on which the guide trough is mounted. The values and part numbers are specified in the table on the right. The standard length of the trough components and glide bars is 6.56 ft (2 m). The required overall length of the guide trough directly correlates to the length of travel.

Example:

Length of travel 164 ft (50 m)
Center mounted

Required guide troughs:

164 ft (50 m) guide trough without glide bar
82 ft (25 m) glide bar
= 25 sections of 6.56 ft (2 m) guide trough

Part No. 95-30

= 13 sections of 6.56 ft (2 m) glide bar

Part No. 92-01

Required number of installation sets:

= Number of guide trough components + 1
= 25 + 1 = 26

Part number of the installation sets

95-50-XXX

Example:

95-50-250 for 9.84" (250 mm) long profile rail.



Width of Crossbar
58-075-200-0

	B_{Ri}	Part No. Installation Set
-050	2.80 (71)	95-50-200
-075	3.78 (96)	95-50-225
-100	4.76 (121)	95-50-250
-125	5.75 (146)	95-50-275
-150	6.73 (171)	95-50-300
-175	7.72 (196)	95-50-325
-200	8.70 (221)	95-50-350

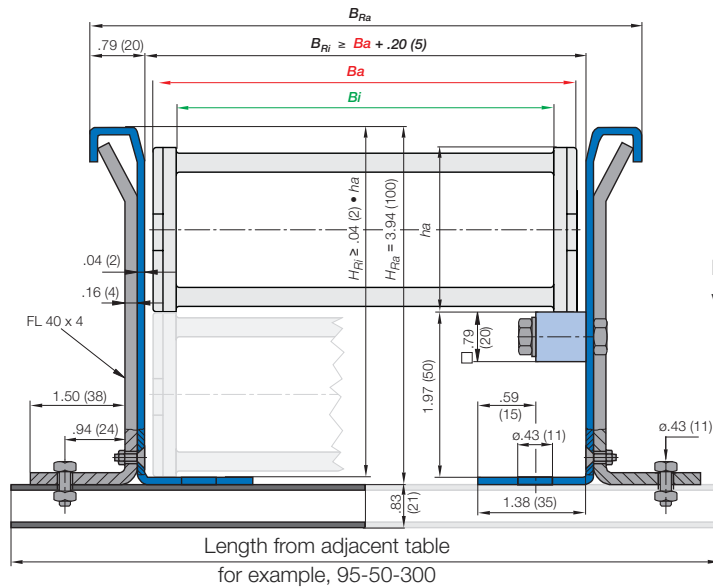

- Guide trough
- Glide bars
- Installation set "Basic"
- C-profile rail

Individual attachment without profile rail

Standard length profile rail

* Specialized guide trough available upon request

PDF: www.igus.com/e-chain-pdfs
Specs/CAD/RFQ: www.igus.com/e-chains
RoHS info: www.igus.com/RoHS



Price Index

Series R68

Special Features / Options

ESD classification:
Electrically conductive
ESD/ATEX version upon request



Flammability Class
VDE 0304 IIC UL94 HB



iF-Design Award Winner

Assembly Tips

To open the Energy Tube Series R, lift up the lid (with a screwdriver) and remove the lid

Other Installation Methods

Vertical, hanging ≤ 197 ft (60 m)

Vertical, standing ≤ 13.12 ft (4 m)

Side-mounted, un supp. ≤ 6.56 ft (2 m)

Rotary requires further calculation

Usage Guidelines

- If particularly quiet operation is required
- If very high speeds are required
- If chip protection is subject to stringent requirements



- If a particularly low-cost solution is the main factor
➤ **Series R167/R168 E2 Tubes**
- If no chip protection is required
➤ **Series 340/350 E2 Medium**

Features & Benefits

- 1 Large pins for high stability
- 2 Protection for cables and hoses against hot chips
- 3 Small pitch for low-noise, smooth operation
- 4 Removable lids along the outer radius
- 5 Smooth, chip-repellent exterior
- 6 KMA mounting brackets with attachment capabilities on all sides
- 7 Fully enclosed
- 8 Integrated strain relief available especially for Energy Tubes

Order Example: Complete Energy Chain®

Please indicate chain length or number of links. Example:

[energy chain® configurator](#)
3.28 ft (1 m) **68-100-100-0****Energy Chain®**With 2 separators **311** assembled every 2nd link**Interior Separation**1 Set **680-100-12****Mounting Bracket**

Energy Chain System® E2 Tubes Series R68 Installation Dimensions

energy chain® configurator



R68

Short travel, unsupported length

- FL_B = unsupported with permitted sag
 - FL_G = unsupported with straight upper run
- Further information Design, Chapter 1

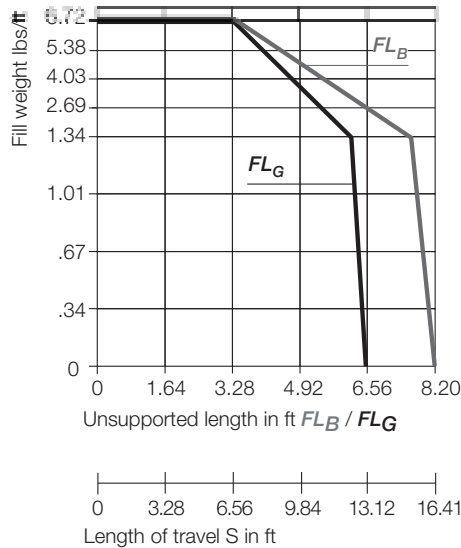
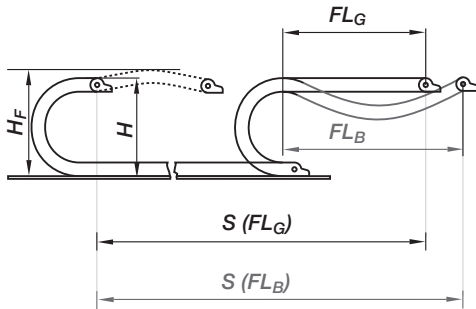

Short Travels - Unsupported



Unsupported Energy Chains® feature positive camber over short travels. This must be accounted for when specifying the clearance height. Please refer to **Installation dimensions** for further details.

Legend

- S = Length of travel
- R = Bending radius
- H = Nominal clearance height
- D = Overlength Energy Chain® radius in final position
- $K = \pi \cdot R + \text{safety buffer}$
- H_f = Required clearance height
- H_{R1} = Trough inner height
- H_2 = *Mounting height
- D_2 = Overlength - long travels, gliding
- K_2 = *Add-on
- *If the mounting bracket location is set lower

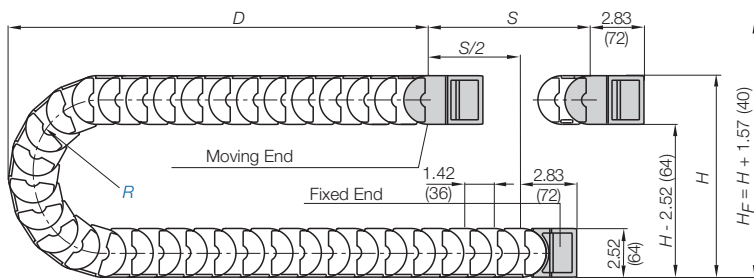

Pitch per link = 1.42" (36 mm)
Links per foot (m) = 8.53 (28)
For center mount applications:
Chain length = $S/2 + K$

The required clearance height: $H_f = H + 1.57$ in. (40 mm) (with 1.68 lbs/ft (2.5 kg/m) fill weight. Please consult igus® if space is particularly restricted.

R	3.94 (100)	4.92 (125)	5.91 (150)	6.89 (175)	7.87 (200)	8.86 (225)	9.84 (250)	11.81 (300)
H	10.39 (264)	12.36 (314)	14.33 (364)	16.30 (414)	18.27 (464)	20.24 (514)	22.20 (564)	26.14 (664)
D	7.32 (186)	8.31 (211)	9.29 (236)	10.28 (261)	11.26 (286)	12.24 (311)	13.23 (336)	15.20 (386)
K	15.35 (390)	18.31 (465)	21.46 (545)	24.60 (625)	27.76 (705)	30.71 (780)	33.86 (860)	39.96 (1015)

For long travels with lowered mounting height

Long travel lengths from 32.8 ft. (10 m) to max. 328 ft. (100 m)

For center mount applications:
Chain length = $S/2 + K_2$

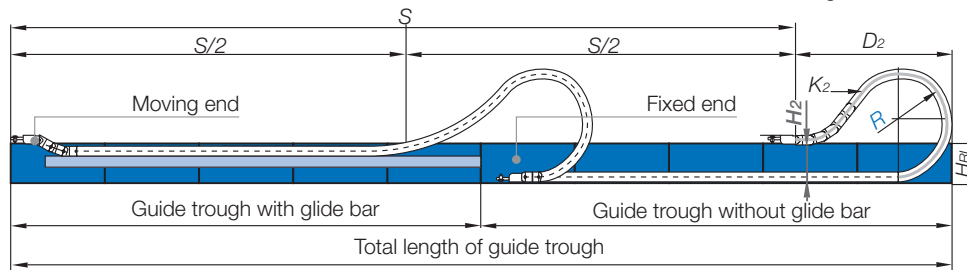

Long Travels - Gliding



If the unsupported length is exceeded, the Energy Chain®/Tube must glide on itself. This requires a guide trough. Design, Chapter 1

R	3.94 (100)	4.92 (125)	5.91 (150)	6.89 (175)	7.87 (200)	8.86 (225)	9.84 (250)	11.81 (300)
H_2	10.43 (265)	11.18 (284)	11.18 (284)	11.18 (284)	11.18 (284)	11.18 (284)	11.18 (284)	11.18 (284)
D_2	7.87 (200)	14.57 (370)	17.32 (440)	21.26 (540)	25.59 (650)	27.56 (700)	33.46 (850)	41.34 (1050)
K_2	19.69 (500)	25.51 (648)	31.18 (792)	35.43 (900)	43.94 (1116)	49.96 (1269)	58.11 (1476)	70.87 (1800)

Speed / acceleration FL_G	max. 32.8 ft/s (10 m/s) / max. 328 ft/s ² (100 m/s ²)
Speed / acceleration FL_B	max. 9.84 ft/s (3 m/s) / max. 19.69 ft/s ² (6 m/s ²)
Gliding speed / acceleration (maximum)	max. 9.84 ft/s (3 m/s) / max. 32.8 ft/s ² (10 m/s ²)
Material - permitted temperature	igumid G / -40°F (-40°C) up to +248°F (+120°C)
Flammability Class, igumid G	VDE 0304 IIC UL94 HB

Technical Data



Details of material properties

Chapter 1

PDF: www.igus.com/e-chain-pdfs
Specs/CAD/RFQ: www.igus.com/e-chains
RoHS info: www.igus.com/RoHS



Series R68 - Energy Tube snap-open along the outer radius

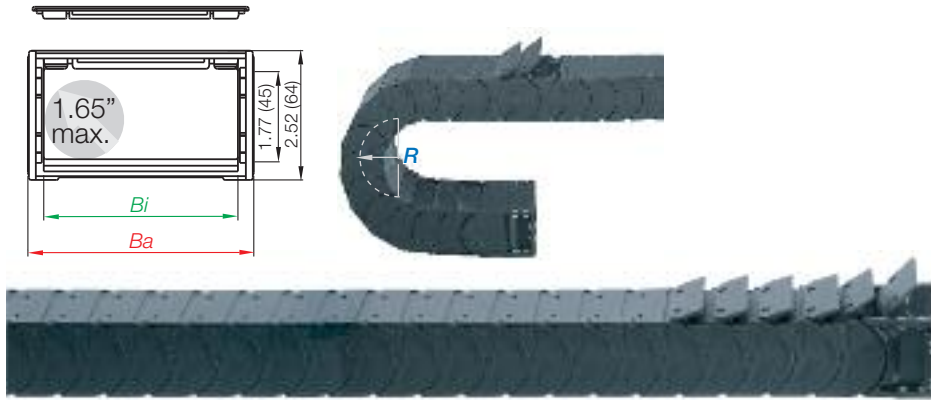

Part Number Structure

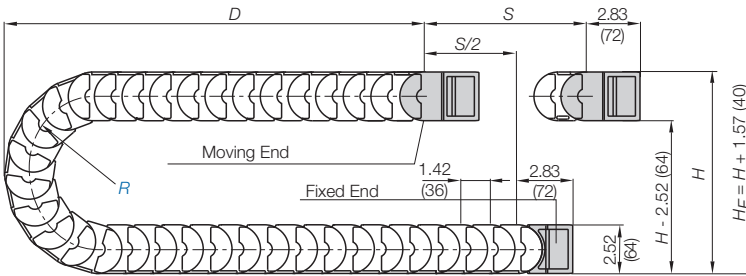
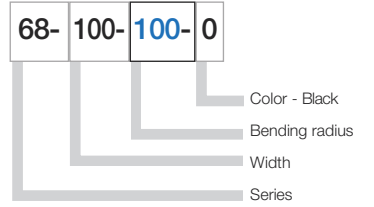

Supplement part number with required radius. Example: R68-100--0
Pitch: 1.42 in. (36 mm) per link links/ft (m) = 8.53 (28)

Part Number	<i>Bi</i> in. (mm)	<i>Ba</i> in. (mm)	Weight lbs/ft (kg/m)
68-050- <input type="text" value=""/> -0	1.97 (50)	2.68 (68)	≈ 1.28 (1.90)
68-075- <input type="text" value=""/> -0	2.95 (75)	3.66 (93)	≈ 1.46 (2.18)
68-100- <input type="text" value=""/> -0	3.94 (100)	4.65 (118)	≈ 1.65 (2.46)
68-115- <input type="text" value=""/> -0	4.53 (115)	5.24 (133)	≈ 1.77 (2.63)
68-125- <input type="text" value=""/> -0	4.92 (125)	5.63 (143)	≈ 1.86 (2.77)
68-150- <input type="text" value=""/> -0	5.91 (150)	6.61 (168)	≈ 2.05 (3.05)
68-175- <input type="text" value=""/> -0	6.89 (175)	7.60 (193)	≈ 2.26 (3.36)
68-200- <input type="text" value=""/> -0	7.87 (200)	8.58 (218)	≈ 2.45 (3.64)
68-225- <input type="text" value=""/> -0	8.86 (225)	9.57 (243)	≈ 2.63 (3.92)
68-250- <input type="text" value=""/> -0	9.84 (250)	10.55 (268)	≈ 2.84 (4.23)

Choose from the radii below for all of the above sizes

Radius (mm) Example: R68-100--0

	100	125	150	175	200	225	250	300
R	3.94 (100)	4.92 (125)	5.91 (150)	6.89 (175)	7.87 (200)	8.86 (225)	9.84 (250)	11.81 (300)
H	10.39 (264)	12.36 (314)	14.33 (364)	16.30 (414)	18.27 (464)	20.24 (514)	22.20 (564)	26.14 (664)
D	7.32 (186)	8.31 (211)	9.29 (236)	10.28 (261)	11.26 (286)	12.24 (311)	13.23 (336)	15.20 (386)
K	15.35 (390)	18.31 (465)	21.46 (545)	24.60 (625)	27.76 (705)	30.71 (780)	33.86 (860)	39.96 (1015)

Energy Chain System® E2 Tubes

Series R68

Interior Separation

energy chain® configurator



R68

Option 1: Vertical separators

Vertical separators are used if a vertical subdivision of the Energy Tube interior is required. By standard, vertical separators are assembled every other Energy Tube link.

STANDARD

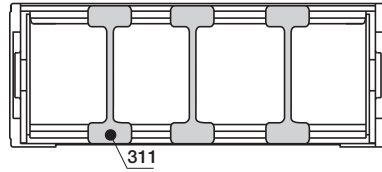

- **Standard separator 301 for Energy Tubes**

This separator is used for general subdivision of Energy Tubes.

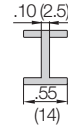

Vertical Separator

Unassembled	Part No. 301
Assembled	Part No. 311

Option 2: Full-width shelf

It is ideal for use in applications involving many thin cables with similar or identical diameters. This shelf slides into place and spans the entire width of the chain.

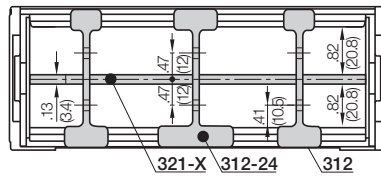

- **Slotted separator 302 for Energy Tubes**

This component is used to form the basic pattern of a shelf system.

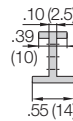

Slotted Separator

Unassembled	Part No. 302
Assembled	Part No. 312

Shelves 320-XX

Shelves can be inserted at 3 different heights in .47" (12mm) increments

Width X in. (mm)	Part No. Unassembled	Part No. Assembled
1.97 (050)	320-050	321-050
2.95 (075)	320-075	321-075
3.94 (100)	320-100	321-100
4.53 (115)	320-115	321-115
4.92 (125)	320-125	321-125
5.91 (150)	320-150	321-150
6.89 (175)	320-175	321-175
7.87 (200)	320-200	321-200

- **Slotted separator 302-24 for Energy Tubes**

This component is used to form the basic pattern of a shelf system.

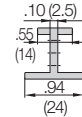

Slotted Separator

Unassembled	Part No. 302-24
Assembled	Part No. 312-24

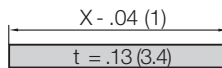

Option 3: Shelves

It is ideal for use in applications involving many cables with similar or identical diameters. Partial separation into individual compartments can be achieved and can be used across the entire width.

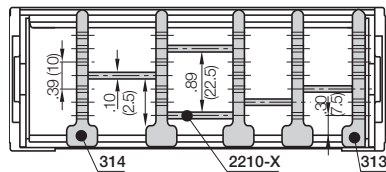

- **Side plate 303 for Energy Tubes**

This component is used to form the basic pattern of a shelf system.

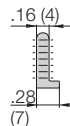

Side Plate

Unassembled	Part No. 303
Assembled	Part No. 313

Shelves 2200-XX

These components form the basic pattern of a shelf system. Shelves of various widths can be arranged at 7 different heights in .20" (5mm) increments

Width X in. (mm)	Part No. Unassembled	Part No. Assembled	Width X in. (mm)	Part No. Unassembled	Part No. Assembled
.71 (18)	2200-18	2210-18	2.28 (58)	2200-58	2210-58
.91 (23)	2200-23	2210-23	2.68 (68)	2200-68	2210-68
1.10 (28)	2200-28	2210-28	2.87 (73)	2200-73	2210-73
1.30 (33)	2200-33	2210-33	3.46 (88)	2200-88	2210-88
1.50 (38)	2200-38	2210-38	3.90 (99)	2200-99	2210-99
1.69 (43)	2200-43	2210-43	4.88 (124)	2200-124	2210-124
1.89 (48)	2200-48	2210-48	5.87 (149)	2200-149	2210-149

- **Vertical separator 304 for Energy Tubes**

This component is used to form the basic pattern of a shelf system.

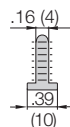

Vertical Separator

Unassembled	Part No. 304
Assembled	Part No. 314

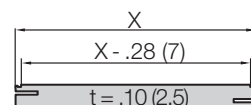

PDF: www.igus.com/e-chain-pdfs
 Specs/CAD/RFQ: www.igus.com/e-chains
 RoHS info: www.igus.com/RoHS



igus® Energy Chain System®

Telephone 1-800-521-2747
Fax 1-401-438-7270

Internet: <http://www.igus.com>
email: sales@igus.com
QuickSpec: <http://www.igus.com/quickspec>

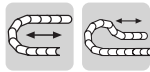

Standard

Option 1: pivoting

- Unsupported and gliding applications
- Space-restricted conditions
- Mounting points on all sides
- KMA with Quickflange option available for short and long travels

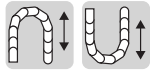
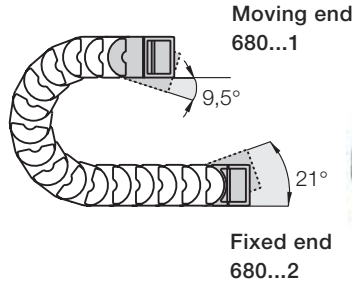

Option 2: locking

- Vertical hanging/standing travels
- Extreme speeds and accelerations
- Mounting points on all sides
- Flush mounting at both ends of the Energy Tube
- KMA with Quickflange option

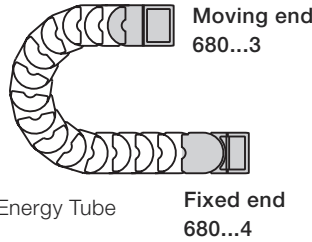

Part Number Structure

680-050-12-QF

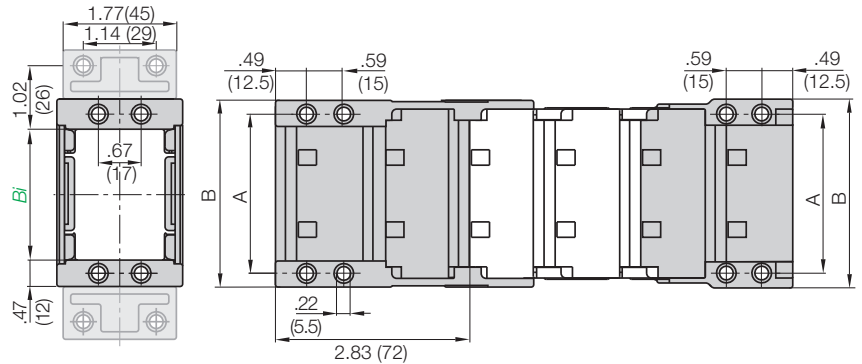
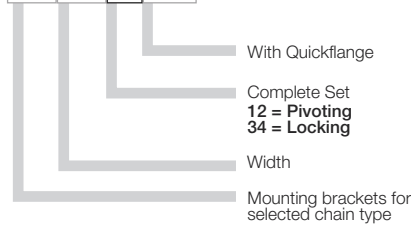

Full set, for both ends:

680-050-12-QF Full set, each part with pin/bore + tiewrap plate

Single-part order:

680-050-1-QF Mounting bracket with bore + tiewrap plate

680-050-2-QF Mounting bracket with pin + tiewrap plate



Quickflange unassembled
Part number 16800-QF

For Tube Type	Part No. Full set with Tiewrap Plate	Part No. Full Set with Quickflange	Dimension A		Dimension B	
			in.	(mm)	in.	(mm)
68-050	680-050- <input type="checkbox"/>	680-050- <input type="checkbox"/> QF	2.44	(62)	2.91	(74)
68-075	680-075- <input type="checkbox"/>	680-075- <input type="checkbox"/> QF	3.43	(87)	3.90	(99)
68-100	680-100- <input type="checkbox"/>	680-100- <input type="checkbox"/> QF	4.41	(112)	4.88	(124)
68-115	680-115- <input type="checkbox"/>	680-115- <input type="checkbox"/> QF	5.00	(127)	5.47	(139)
68-125	680-125- <input type="checkbox"/>	680-125- <input type="checkbox"/> QF	5.39	(137)	5.87	(149)
68-150	680-150- <input type="checkbox"/>	680-150- <input type="checkbox"/> QF	6.38	(162)	6.85	(174)
68-175	680-175- <input type="checkbox"/>	680-175- <input type="checkbox"/> QF	7.36	(187)	7.83	(199)
68-200	680-200- <input type="checkbox"/>	680-200- <input type="checkbox"/> QF	8.35	(212)	8.82	(224)
68-225	680-225- <input type="checkbox"/>	680-225- <input type="checkbox"/> QF	9.33	(237)	9.80	(249)
68-250	680-250- <input type="checkbox"/>	680-250- <input type="checkbox"/> QF	10.31	(262)	10.79	(274)

The following parts are required for attachment of the mounting brackets:

- **Socket head cap bolt**
M5* DIN 912-8.8
8 pieces/set
- **Washer**
5.3 DIN 125-ST
8 pieces/set
- **Hexagon nut**
M5 DIN 934-8
8 pieces/set

* The length of the socket head cap bolt is dependent on the thickness of the attachment base.

12 or 34

For pivoting brackets choose 12

For locking brackets choose 34

Example: 680-050- 34 QF



Integrated strain relief for E2 Energy Tubes - Series R

- Strain relief disappears completely within the Energy Tube
- Easy to assemble, no screws required

Part. No.	Width (mm)	Number of teeth
3050-Z	1.97 (50)	5
3075-Z	2.95 (75)	7

Number of tiewrap plates 3050-Z for selected inner width *Bi*

<i>Bi</i> in. (mm)	Width tiewrap plate in. (mm)	Number of tiewrap plates <i>n</i>	Total number of teeth
1.97 (50)	–	–	–
2.95 (75)	–	–	–
3.94 (100)	1.97 (50)	1	5
4.52 (115)	1.97 (50)	1	5
4.92 (125)	1.97 (50)	1	5
5.91 (150)	1.97 (50)	2	10
6.89 (175)	1.97 (50)	2	10
7.87 (200)	1.97 (50)	3	15
8.86 (225)	1.97 (50)	3	15
9.89 (250)	1.97 (50)	4	20

Number of tiewrap plates 3075-Z for selected inner width *Bi*

<i>Bi</i> in. (mm)	Width tiewrap plate in. (mm)	Number of tiewrap plates <i>n</i>	Total number of teeth
1.97 (50)	–	–	–
2.95 (75)	–	–	–
3.94 (100)	–	–	–
4.52 (115)	2.95 (75)	1	7
4.92 (125)	2.95 (75)	1	7
5.91 (150)	2.95 (75)	1	7
6.89 (175)	2.95 (75)	2	14
7.87 (200)	2.95 (75)	2	14
8.86 (225)	2.95 (75)	3	21
9.89 (250)	2.95 (75)	3	21

PDF: www.igus.com/e-chain-pdfs
Specs/CAD/RFQ: www.igus.com/e-chains
RoHS info: www.igus.com/RoHS



Guide troughs are used with applications where the upper run of the Energy Tube glides on the lower run. If using igus steel guide troughs, the following components are required:

- Full travel length of guide trough
Part number 93-30
- 1/2 travel length glide bars
Part number 93-01
- Installation sets as end connectors
Part number 93-50-XX

-XX indicates the length of the profile rail on which the guide trough is mounted. The values and part numbers are specified in the table on the right. The standard length of the trough components and glide bars is 6.56 ft (2 m). The required overall length of the guide trough directly correlates to the length of travel.

Example:

Length of travel 164 ft (50 m)
Center mounted

Required guide troughs:

164 ft (50 m) guide trough, 82 ft (25 m) glide bar
= 25 sections of 6.56 ft (2 m) guide trough
Part No. 93-30
= 13 sections of 6.56 ft (2 m) glide bar

Part No. 93-01

Required number of installation sets:

= Number of guide trough components + 1
= 25 + 1 = 26

Part number of the installation sets

93-50-XXX

Example:

93-50-250 for 9.84" (250 mm) long profile rail.



Width of Crossbar
68-075-200-0

	B_{Ri}	Installation Part No.
-050	2.87 (73)	93-50-200
-075	3.86 (98)	93-50-225
-100	4.84 (123)	93-50-250
-115	5.43 (138)	93-50-250
-125	5.83 (148)	93-50-275
-150	6.81 (173)	93-50-300
-175	7.80 (198)	93-50-325
-200	8.78 (223)	93-50-350
-225	9.76 (248)	93-50-375
-250	10.75 (273)	93-50-400

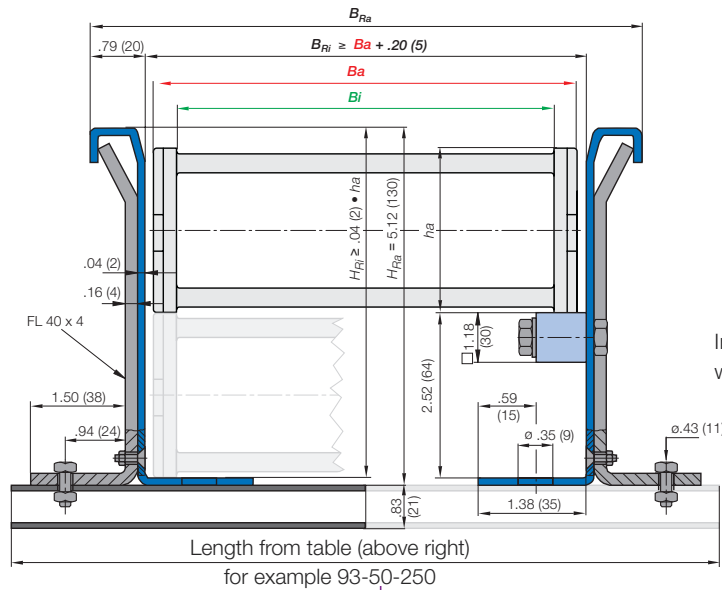

- Guide trough
- Glide bars
- Installation set "Basic"
- C-profile rail

Individual attachment without profile rail

* Specialized guide trough available upon request

Standard length profile rail

PDF: www.igus.com/e-chain-pdfs
Specs/CAD/RFQ: www.igus.com/e-chains
RoHS info: www.igus.com/RoHS



Price Index



Series R117/R118

Special Features / Options



ESD classification:
Electrically conductive
ESD/ATEX version upon request



Flammability Class
VDE 0304 IIC UL94 HB



iF-Design Award Winner

Assembly Tips

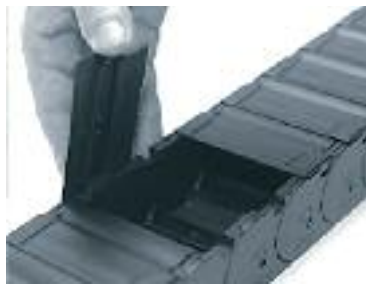

Lids of the Energy Tube Series R100 are hinged for easy access

Usage Guidelines



- If snap-open accessibility along inner or outer radius is required
- If price is an issue
- If flush attachment is required



- For smoother running and smaller pitch
➤ **Series R48 E2 Tubes**
- If accessibility along the sides of the radius is required
➤ **Series R760 E4/100**

Features & Benefits

- 1 Effective chip protection, even against hot metal chips
- 2 Double stop dog for strong unsupported length
- 3 Smooth, chip-repellent exterior
- 4 Lateral glide surfaces for side-mounted operation
- 5 Universal KMA mounting brackets with attachment capability on all sides
- 6 Snap-open from the side, covered pin/bore connection
- 7 Space-efficient with optimized ratio of inner to outer dimension
- 8 Snap-open lids along the inner or outer radius

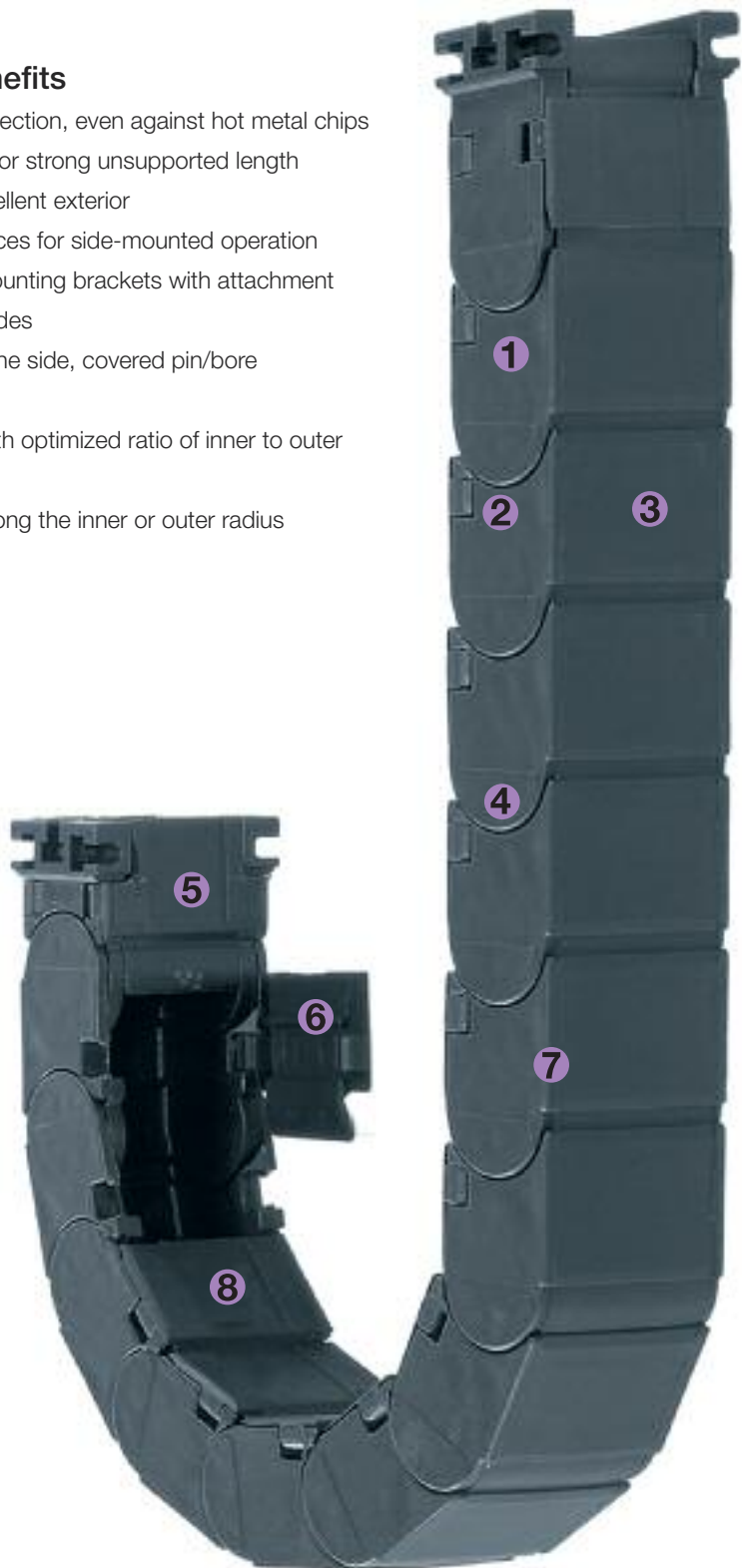

Order Example: Complete Energy Chain®

Please indicate chain length or number of links. Example:

energy chain® configurator ▶

3.28 ft (1 m) 117-100-100-0



Energy Chain®

With 2 separators 1186-01 assembled every 2nd link



Interior Separation

1 Set 11800-100-14



Mounting Bracket

Energy Chain System® E2 Medium Series R117/R118 Installation Dimensions

energy chain® configurator



R117
R118

Short travel, unsupported length

- FL_B = unsupported with permitted sag
 - FL_G = unsupported with straight upper run
- Further information Design, Chapter 1

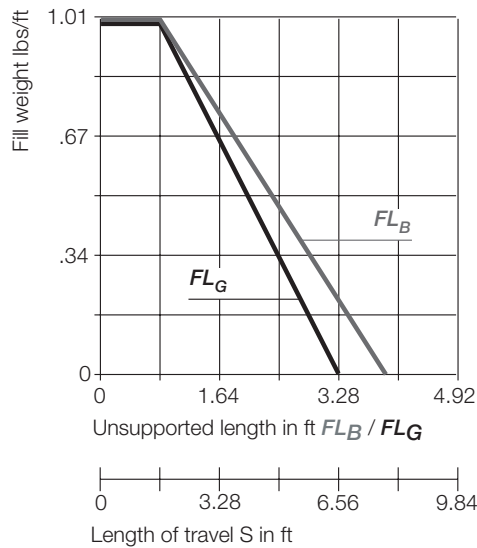
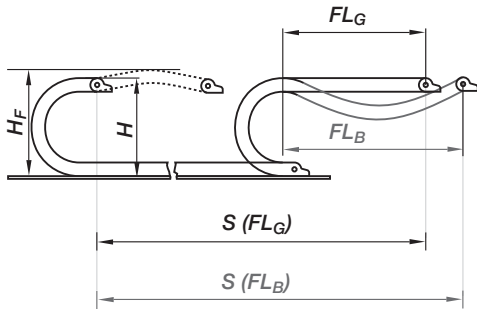

Short Travels - Unsupported



Unsupported Energy Chains® feature positive camber over short travels. This must be accounted for when specifying the clearance height. Please refer to **Installation dimensions** for further details.

Legend

- S = Length of travel
- R = Bending radius
- H = Nominal clearance height
- D = Overlength Energy Chain® radius in final position
- $K = \pi \cdot R + \text{safety buffer}$
- H_F = Required clearance height

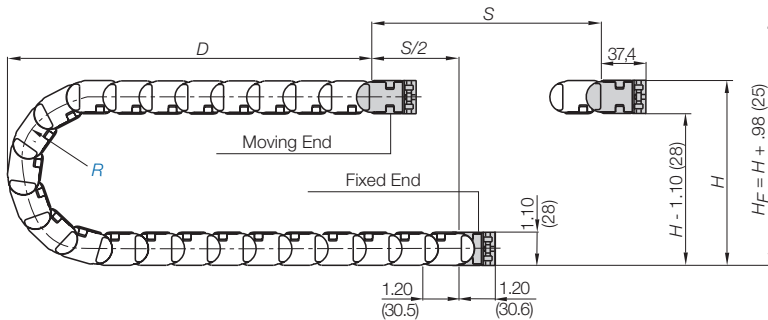

Pitch per link = 1.20" (30.5 mm)
Links per ft (m) = 10.06 (33)
For center mount applications:
Chain length = $S/2 + K$

The required clearance height: $H_F = H + .98$ in. (25 mm) (with .67 lbs/ft (1.0 kg/m) fill weight). Please consult igus® if space is particularly restricted.

R	2.48 (063)	2.95 (075)	3.94 (100)	4.33 (110)	4.92 (125)	5.71 (145)	7.09 (180)
H	6.06 (154)	7.01 (178)	8.98 (228)	9.76 (248)	10.94 (278)	12.52 (318)	15.28 (388)
D	4.84 (123)	5.31 (135)	6.30 (160)	6.69 (170)	7.28 (185)	8.07 (205)	9.45 (240)
K	10.24 (260)	11.81 (300)	14.96 (380)	16.14 (410)	17.91 (455)	20.47 (520)	24.80 (630)

PDF: www.igus.com/e-chain-pdfs
Specs/CAD/RFQ: www.igus.com/e-chains
RoHS info: www.igus.com/RoHS



Speed / acceleration FL_G	max. 32.8 ft/s (10 m/s) / max. 328 ft/s ² (100 m/s ²)
Speed / acceleration FL_B	max. 9.84 ft/s (3 m/s) / max. 19.69 ft/s ² (6 m/s ²)
Gliding speed / acceleration (maximum)	max. 1.64 ft/s (0.5 m/s) / max. 16.4 ft/s ² (5 m/s ²)
Material - permitted temperature	igumid G / -40°F (-40°C) up to +248°F (+120°C)
Flammability Class, igumid G	VDE 0304 IIC UL94 HB

Technical Data



Details of material properties

Chapter 1

Series R117 - hinged, snap-open on both sides of the inner radius

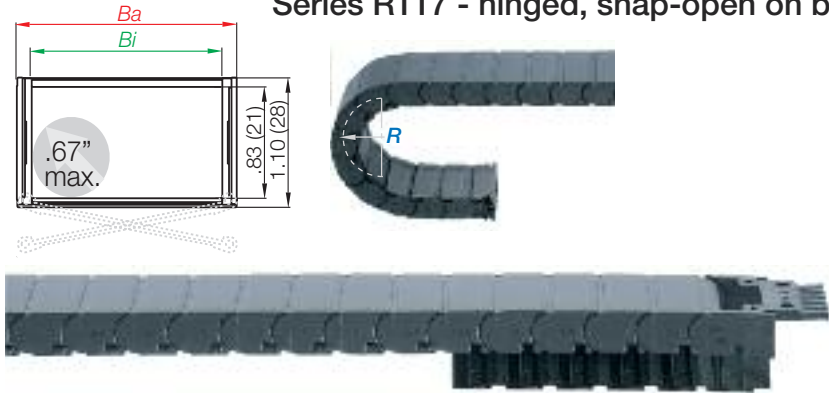

Part Number Structure

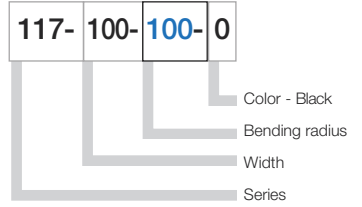

Series R118 - hinged, snap-open on both sides of the outer radius

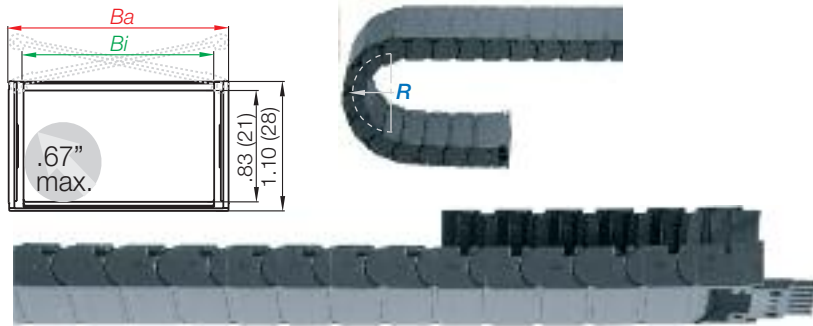

Part Number Structure

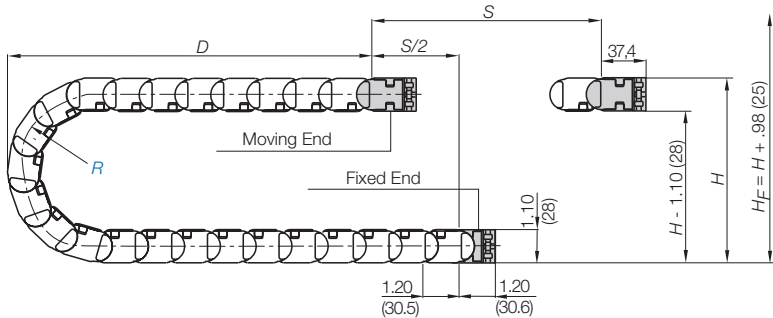
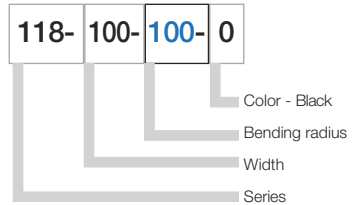

Supplement part number with required radius. Example: 117-100-**100**-0
Pitch: 1.20 in. (30.5 mm) per link links/ft(m) = 10.06 (33)

Part Number.			<i>Bi</i>	<i>Ba</i>	Weight
Snap-open inner radius	Snap-open outer radius		in. (mm)	in. (mm)	lbs/ft (kg/m)
117-020-		<input type="text"/> -0	.79 (20)	1.26 (32)	≈ 0.29 (0.43)
117-025-	118-025-	<input type="text"/> -0	.98 (25)	1.46 (37)	≈ 0.31 (0.46)
117-038-		<input type="text"/> -0	1.50 (38)	1.97 (50)	≈ 0.38 (0.56)
117-048-	118-048-	<input type="text"/> -0	1.89 (48)	2.40 (60)	≈ 0.44 (0.66)
117-063-		<input type="text"/> -0	2.48 (63)	2.95 (75)	≈ 0.51 (0.76)
117-080-	118-080-	<input type="text"/> -0	3.15 (80)	3.62 (92)	≈ 0.60 (0.89)
117-100-		<input type="text"/> -0	3.94 (100)	4.41 (112)	≈ 0.71 (1.06)

Choose from the radii below for all of the above sizes
Radius (mm) Example: 117-100-**100**-0

	063	075	100	110	125	145	180
R	2.48 (063)	2.95 (075)	3.94 (100)	4.33 (110)	4.92 (125)	5.71 (145)	7.09 (180)
H	6.06 (154)	7.01 (178)	8.98 (228)	9.76 (248)	10.94 (278)	12.52 (318)	15.28 (388)
D	4.84 (123)	5.31 (135)	6.30 (160)	6.69 (170)	7.28 (185)	8.07 (205)	9.45 (240)
K	10.24 (260)	1181 (300)	14.96 (380)	16.14 (410)	17.91 (455)	20.47 (520)	24.80 (630)

Energy Chain System® E2 Tubes Series R117/R118 Interior Separation Mounting Brackets - KMA

energy chain® configurator ▶



R117
R118

Option 1: Vertical separators and spacers

Vertical separators are used if a vertical subdivision of the Energy Chain® interior is required. By standard, vertical separators are assembled every other Energy Chain® link. .

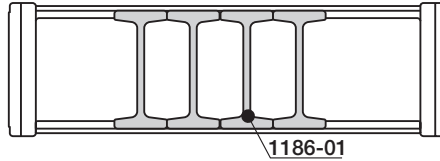

Vertical separator
1185-01

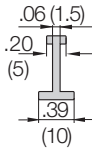

Vertical Separator

Unassembled Part No. 1185-01

Assembled Part No. 1186-01

• Standard separator 1185-01 for Energy Chains®

This separator is used for general subdivision of Energy Chain®.

Mounting Brackets - KMA

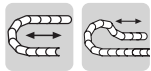

Standard

Option: KMA pivoting

- Short and long travels
- Space restricted
- Corrosion-resistant

Moving end
11800...1

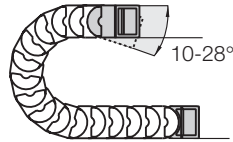

10-28°

Fixed end
11800...4

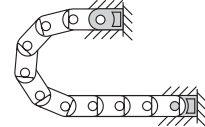

Part Number Structure

11800- 020- 14

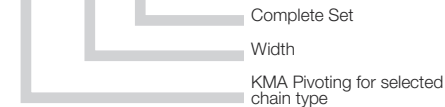

Full set, for both ends:

11800-020-14 Full set, each part with pin/bore

Single-part order:

11800-020-1 Mounting bracket with bore

11800-020-4 Mounting bracket with pin

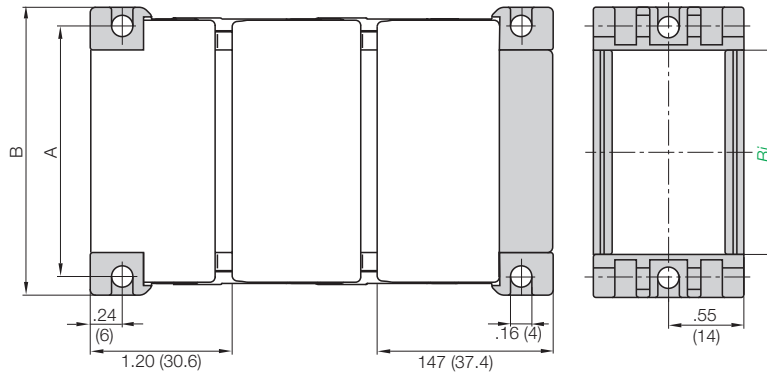

Series	Part No. Full Set	Dimension A		Dimension B	
		in.	(mm)	in.	(mm)
117-020	11800-020-14	1.14	(29)	1.42	(36)
117/118-025	11800-025-14	1.34	(34)	1.61	(41)
117-038	11800-038-14	1.85	(47)	2.13	(54)
117/118-048	11800-048-14	2.24	(57)	2.52	(64)
117-063	11800-063-14	2.83	(72)	3.11	(79)
117/118-080	11800-080-14	3.50	(89)	3.78	(96)
117-100	11800-100-14	4.29	(109)	4.57	(116)

- The mounting brackets are supplied with hexagon nuts and can be attached with M4 bolts, or the mounting brackets may also be attached with M4 socket head cap bolts

PDF: www.igus.com/e-chain-pdfs
Specs/CAD/RFQ: www.igus.com/e-chains
RoHS info: www.igus.com/RoHS



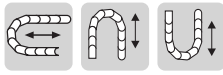

Option: plastic bracket

- For long travels
- Attachment option for strain relief tie-wrap plate
- Locked connection to Energy Tube
- Minimized external width

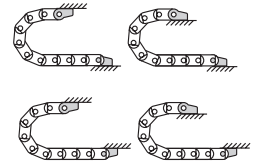
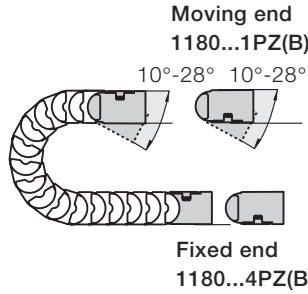

Possible installation configurations -

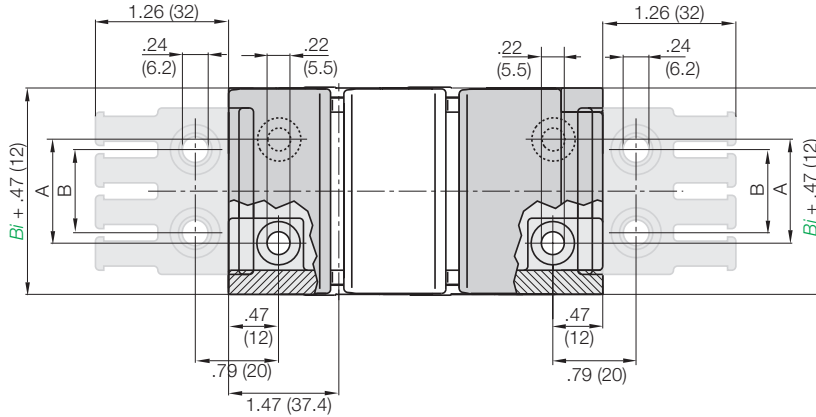

Part Number Structure

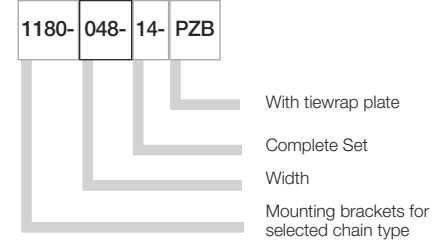

Full set, for both ends:

1180-048-14 Full set, each part with pin/bore

Single-part order:

1180-048-1 Mounting bracket with bore

1180-048-4 Mounting bracket with pin

Part No. Mounting Brackets Full Set
4 parts, 2 with pin, 2 with bore
Series R117/R118:
1180-Width-14

Part No. Mounting bracket with bore
2 parts, 1 left & 1 right
Series R117/R118:
1180-Width-1

Part No. Mounting bracket with pin
2 parts, 1 left & 1 right
Series R117/R118:
1180-Width-4

For Series	Part No. Full Set without Tiewrap Plate	Part No. Full Set with Tiewrap Plate	Dimension A		Dimension B	
			in.	(mm)	in.	(mm)
R117/R118-025	1180-025-14	1180-025-14PZB	.47	(12)	.59	(15)
R117-038	1180-038-14	1180-038-14PZB	.98	(25)	.79	(20)
R117/R118-048	1180-048-14	1180-048-14PZB	1.38	(35)	1.18	(30)
R117-063	1180-063-14	1180-063-14PZB	1.97	(50)	1.57	(40)
R117/R118-080	1180-080-14	1180-080-14PZB	2.64	(67)	2.36	(60)
R117-100	1180-100-14	1180-100-14PZB	3.43	(87)	3.15	(80)

The following parts are required for attachment of the mounting brackets:

- Countersunk bolt M5* DIN 912-8.8
 - Hexagon nut M5 DIN 934-8
- 4 pieces/set

* The length of the socket head cap bolt is dependent on the thickness of the attachment base.

Tiewrap Plates

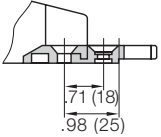

Shown assembled

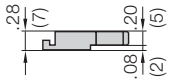

Single tie-wrap plate



Option 1:
Tiewrap plates as an individual part

Available as an individual component, can be fixed onto a mounting bracket with the use of a profile rail.

Tiewrap Plates	n Number of Teeth	Dimension C	Dimension B
2020-ZB	3	1.18 (30)	.59 (15)
2030-ZB	4	1.57 (40)	.79 (20)
2040-ZB	5	1.97 (50)	1.18 (30)
2050-ZB	6	2.36 (60)	1.57 (40)
2070-ZB	8	3.15 (80)	2.36 (60)
2090-ZB	9	3.54 (90)	2.76 (70)
2100-ZB	10	3.94 (100)	3.15 (80)
2125-ZB	12	4.72 (120)	3.94 (100)

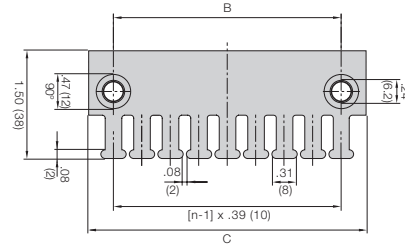

For more information please refer to strain relief section of Chapter 10

Cable tiewraps as individual parts

Cable tiewraps 100 pieces/bag	Width x Length		Maximum Ø		Tensile Strength	
	in.	(mm)	in.	(mm)	lbs	(N)
CFB-001	.19 x 5.91	(4.8 x 150)	1.42	(36)	50	(222)

PDF: www.igus.com/e-chain-pdfs
Specs/CAD/RFQ: www.igus.com/e-chains
RoHS info: www.igus.com/RoHS



Price Index



Series R157/R158

Special Features / Options



ESD classification:
Electrically conductive
ESD/ATEX version upon request



Flammability Class
VDE 0304 IIC UL94 HB

Assembly Tips

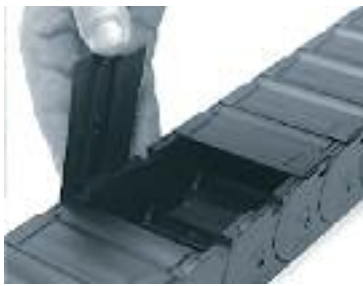

Lids of the Energy Tube Series R100 are hinged for easy access

Usage Guidelines



- If hinged, snap-open accessibility along inner **or** outer radius is required
- If a low-cost, lightweight Energy Tube for many types of applications is required
- If flush attachment is required
- If chip-repellent features are required



- If particularly quiet operation is required
➤ **Series R58 E2 Tubes**
- If snap-open accessibility along both radii simultaneously is required
➤ **Series R770 E4/100**

Features & Benefits

- 1 Effective chip protection even against hot chips
- 2 Space-efficient with optimized ratio of inner dimension to outer dimension
- 3 Snap-open lids along the inner and outer radius
- 4 Snap-open from the side, covered pin/bore connection
- 5 Double stop dog for strong unsupported length
- 6 Universal KMA mounting brackets with attachment capability on all sides
- 7 Lateral glide surfaces for side mounted operation



Order Example: Complete Energy Chain®

Please indicate chain length or number of links. Example:

energy chain® configurator

3.28 ft (1 m) **157-088-100-0**



Energy Chain®

With 2 separators **1586-01** assembled every 2nd link



Interior Separation

1 Set **15800-088-12**



Mounting Bracket

Energy Chain System® E2 Tubes Series R157/R158 Installation Dimensions

energy chain® configurator ▶



R157
R158

Short travel, unsupported length

- FL_B = unsupported with permitted sag
 - FL_G = unsupported with straight upper run
- Further information ▶ Design, Chapter 1

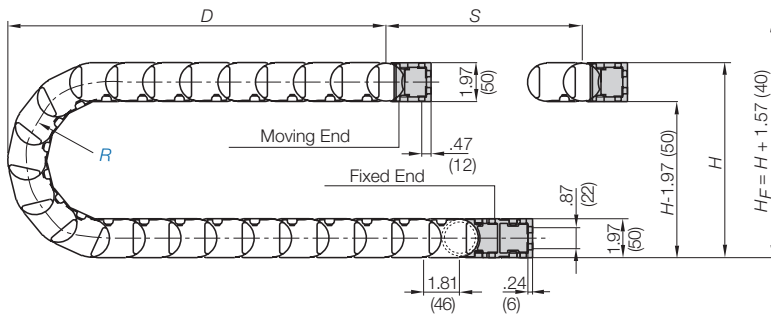
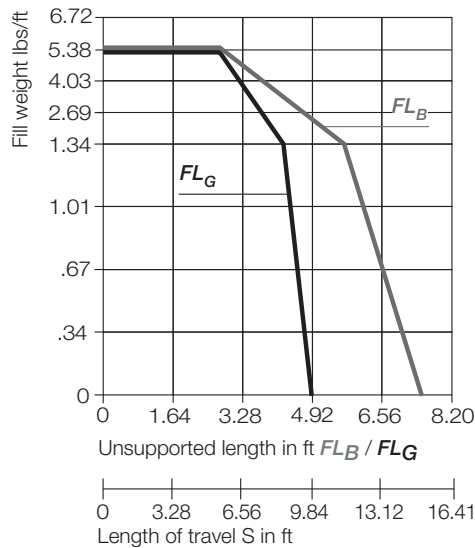
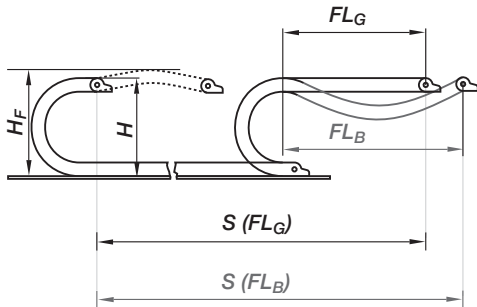

Pitch per link = 1.81" (46 mm)
Links per ft (m) = 6.71 (22)
For center mount applications:
Chain length = $\frac{S}{2} + K$

The required clearance height: $H_F = H + 1.57$ in. (40 mm) (with .67 lbs/ft (1.0 kg/m) fill weight. Please consult igus® if space is particularly restricted.

R	3.94 (100)	4.92 (125)	5.91 (150)	6.89 (175)	7.87 (200)	9.84 (250)
H	9.84 (250)	11.81 (300)	13.78 (350)	15.75 (400)	17.72 (450)	21.65 (550)
D	7.64 (194)	8.62 (219)	9.61 (244)	10.59 (269)	11.57 (294)	13.54 (344)
K	16.14 (410)	19.09 (485)	22.24 (565)	25.39 (645)	28.54 (725)	34.65 (880)

Short Travels - Unsupported



Unsupported Energy Chains® feature positive camber over short travels. This must be accounted for when specifying the clearance height. Please refer to **Installation dimensions** for further details.

Legend

- S = Length of travel
- R = Bending radius
- H = Nominal clearance height
- D = Overlength Energy Chain® radius in final position
- $K = \pi \cdot R + \text{safety buffer}$
- H_F = Required clearance height



PDF: www.igus.com/e-chain-pdfs
Specs/CAD/RFQ: www.igus.com/e-chains
RoHS info: www.igus.com/RoHS



Speed / acceleration FL_G	max. 32.8 ft/s (10 m/s) / max. 328 ft/s ² (100 m/s ²)
Speed / acceleration FL_B	max. 9.84 ft/s (3 m/s) / max. 19.69 ft/s ² (6 m/s ²)
Gliding speed / acceleration (maximum)	max. 1.64 ft/s (0.5 m/s) / max. 16.4 ft/s ² (5 m/s ²)
Material - permitted temperature	igumid G / -40°F (-40°C) up to +248°F (+120°C)
Flammability Class, igumid G	VDE 0304 IIC UL94 HB

Technical Data



Details of material properties

▶ Chapter 1

Series R157 - hinged, snap-open on both sides of the inner radius

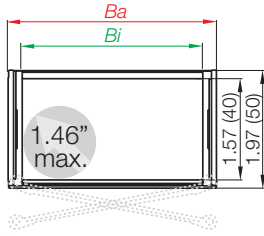

Part Number Structure



- Color - Black
- Bending radius
- Width
- Series

Series R158 - hinged, snap-open on both sides of the outer radius

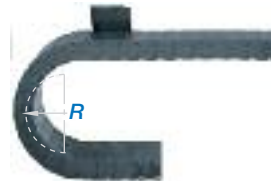
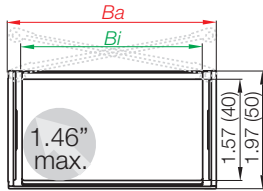

Part Number Structure



- Color - Black
- Bending radius
- Width
- Series

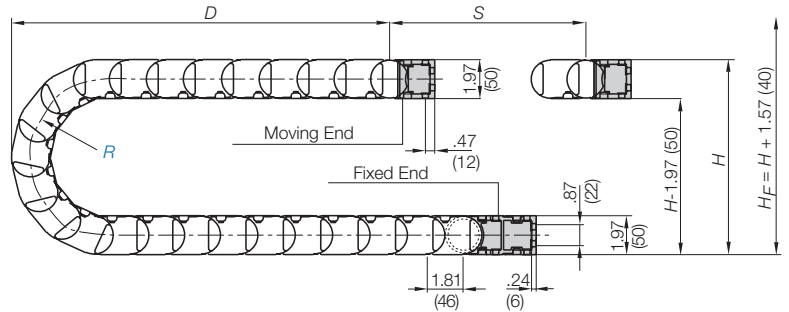

Supplement part number with required radius.
Example: 157-100--0
Pitch: 1.81 in. (46 mm) per link links/ft (m) = 6.71 (22)

Part Number.			<i>Bi</i>	<i>Ba</i>	Weight
Snap-open inner radius	Snap-open outer radius		in. (mm)	in. (mm)	lbs/ft (kg/m)
157-040-*	158-040-*	<input type="text" value=""/> -0	1.57 (40)	2.20 (56)	≈ 0.81 (1.21)
157-050-	158-050-	<input type="text" value=""/> -0	1.97 (50)	2.60 (66)	≈ 0.87 (1.30)
157-075-	158-075-	<input type="text" value=""/> -0	2.95 (75)	3.58 (91)	≈ 1.01 (1.50)
157-088-	158-088-	<input type="text" value=""/> -0	3.46 (88)	4.09 (104)	≈ 1.06 (1.57)
157-090-**	158-090-**	<input type="text" value=""/> -0	3.46 (88)	4.09 (104)	≈ 1.10 (1.63)
157-100-	158-100-	<input type="text" value=""/> -0	3.94 (100)	4.57 (116)	≈ 1.15 (1.71)
157-125-	158-125-	<input type="text" value=""/> -0	4.92 (125)	5.55 (141)	≈ 1.29 (1.92)
157-135-	158-135-	<input type="text" value=""/> -0	5.31 (135)	5.91 (150)	≈ 1.41 (2.10)
157-150-	158-150-	<input type="text" value=""/> -0	5.91 (150)	6.54 (166)	≈ 1.43 (2.13)
157-175-	158-175-	<input type="text" value=""/> -0	6.89 (175)	7.52 (191)	≈ 1.57 (2.34)
157-200-	158-200-	<input type="text" value=""/> -0	7.87 (200)	8.50 (216)	≈ 1.71 (2.55)

Choose from the radii below for all of the above sizes

Radius (mm) Example: 157-100--0

	100	125	150	175	200	250
R	3.94 (100)	4.92 (125)	5.91 (150)	6.89 (175)	7.87 (200)	9.84 (250)
H	9.84 (250)	11.81 (300)	13.78 (350)	15.75 (400)	17.72 (450)	21.65 (550)
D	7.64 (194)	8.62 (219)	9.61 (244)	10.59 (269)	11.57 (294)	13.54 (344)
K	16.14 (410)	19.09 (485)	22.24 (565)	25.39 (645)	28.54 (725)	34.65 (880)

*Removable lid only, not hinged
**Same dimensions as 157/158-088 - removable lids only

Energy Chain System® E2 Tubes

Series R157/R158

Interior Separation

energy chain® configurator 



R157
R158

Option 1: Vertical separators

Vertical separators are used if a vertical subdivision of the Energy Tube interior is required. By standard, vertical separators are assembled every other Energy Tube link.

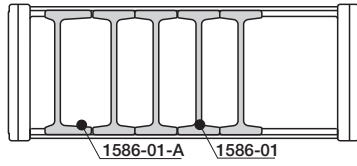

 STANDARD

- **Standard separator 1585-0 for Energy Tubes**

This separator is used for general subdivision of Energy Tubes.

- **Asymmetrical separator 1585-01-A for Energy Tubes**

This separator is used for subdivision of Energy Tubes in side-mounted applications.



Vertical Separator

Unassembled Part No. 1585-01
Assembled Part No. 1586-01

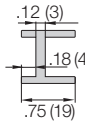

Asymmetrical Separator

Unassembled Part No. 1585-01-A
Assembled Part No. 1586-01-A

Option 2: Full-width shelf

It is ideal for use in applications involving many thin cables with similar or identical diameters. This shelf slides into place and spans the entire width of the chain.

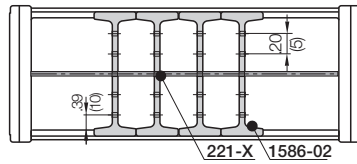

- **Slotted separator 1585-02 for Energy Tubes**

This component is used to form the basic pattern of a shelf system.

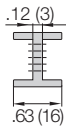

Vertical Separator, slotted

Unassembled Part No. 1585-02
Assembled Part No. 1586-02

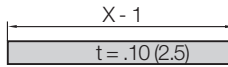

Shelves 220-XX

Shelves can be inserted at 3 different heights in .20" (5mm) increments

Width X in. (mm)	Part No. Unassembled	Part No. Assembled
1.57 (40)	220-40	221-40
1.97 (50)	220-50	221-50
2.95 (75)	220-75	221-75
3.46 (88)	220-88	221-88
3.94 (100)	220-100	221-100
4.92 (125)	220-125	221-125
5.31 (135)	220-135	221-135
5.91 (150)	220-150	221-150
6.89 (175)	220-175	221-175
7.87 (200)	220-200	221-200

Option 3: Shelves

It is ideal for use in applications involving many cables with similar or identical diameters. Partial separation into individual compartments can be achieved and can be used across the entire width.

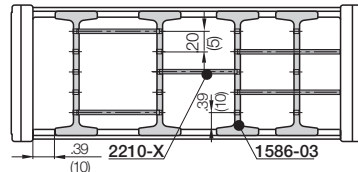

- **Slotted separator 1585-03 for Energy Tubes**

This component is used to form the basic pattern of a shelf system.

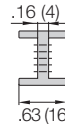

Vertical Separator, slotted

Unassembled Part No. 1585-03
Assembled Part No. 1586-03

Shelves 2200-XX

These components form the basic pattern of a shelf system. Shelves of various widths can be arranged at 5 different heights in .20" (5mm) increments

Width X in. (mm)	Part No. Unassembled	Part No. Assembled	Width X in. (mm)	Part No. Unassembled	Part No. Assembled
.71 (18)	2200-18	2210-18	2.28 (58)	2200-58	2210-58
.91 (23)	2200-23	2210-23	2.68 (68)	2200-68	2210-68
1.10 (28)	2200-28	2210-28	2.87 (73)	2200-73	2210-73
1.30 (33)	2200-33	2210-33	3.46 (88)	2200-88	2210-88
1.50 (38)	2200-38	2210-38	3.90 (99)	2200-99	2210-99
1.69 (43)	2200-43	2210-43	4.88 (124)	2200-124	2210-124
1.89 (48)	2200-48	2210-48	5.87 (149)	2200-149	2210-149

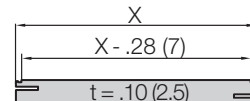

PDF: www.igus.com/e-chain-pdfs
Specs/CAD/RFQ: www.igus.com/e-chains
RoHS info: www.igus.com/RoHS



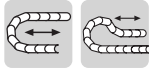

Standard

Option 1: KMA pivoting

- Extended, pivoting
- Easy to install
- Universal use
- Corrosion-resistant
- Long travels with lowered mounting height possible

Moving end
15800/15801...1

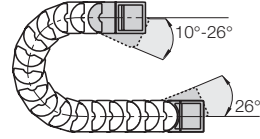

Fixed end
15800/15801...2

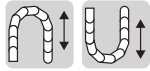
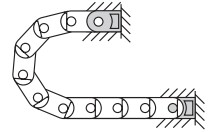

Option 2: KMA locking

- Extended, locking
- Easy to install
- Flush mounting at both ends of the Energy Tube
- Mounting points on all sides
- Corrosion resistant

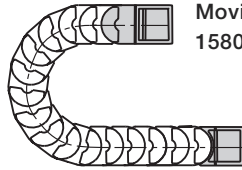

Moving end
15800/15801...3

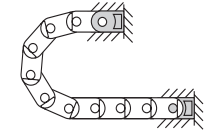

Fixed end
15800/15801...4

Part Number Structure

15800-100-12

Complete Set
12 = Pivoting
34 = Locking

Width

KMA Pivoting for selected chain type

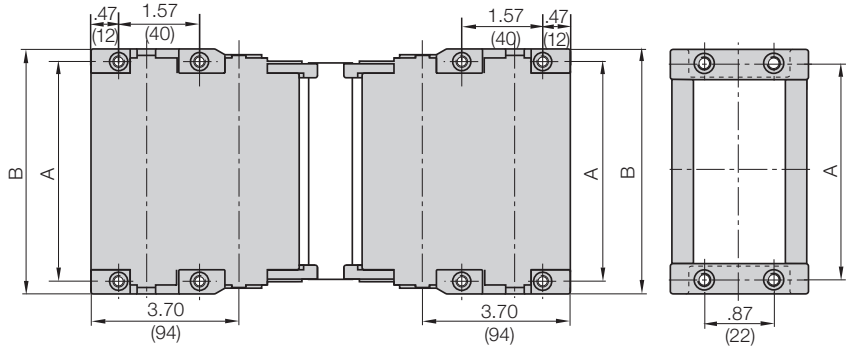

Full set, for both ends:

15800-100-12 Full set, each part with pin/bore

Single-part order:

15800-100-1 Mounting bracket with bore

15800-100-2 Mounting bracket with pin



Quickflange upon request
• Unassembled
Part number 16800-QF

Series	Part No.	Dimension A		Dimension B	
		in.	(mm)	in.	(mm)
157/158-040	15801-040- <input type="checkbox"/>	1.97	(50)	2.40	(61)
157/158-050	15800-050- <input type="checkbox"/>	2.40	(60)	2.80	(71)
157/158-075	15800-075- <input type="checkbox"/>	3.35	(85)	3.78	(96)
157/158-088	15800-088- <input type="checkbox"/>	3.86	(98)	4.29	(109)
157/158-090	15801-090- <input type="checkbox"/>	3.86	(98)	4.29	(109)
157/158-100	15800-100- <input type="checkbox"/>	4.33	(110)	4.76	(121)
157/158-125	15800-125- <input type="checkbox"/>	5.31	(135)	5.75	(146)
157/158-135	15800-135- <input type="checkbox"/>	5.71	(145)	6.14	(156)
157/158-150	15800-150- <input type="checkbox"/>	6.30	(160)	6.73	(171)
157/158-175	15800-175- <input type="checkbox"/>	7.28	(185)	7.72	(196)
157/158-200	15800-200- <input type="checkbox"/>	8.27	(210)	8.70	(221)

The following parts are required for attachment of the mounting brackets:

- **Socket head cap bolt**
M5* DIN 912-8.8
8 pieces/set
- **Washer**
5.3 DIN 125-ST
8 pieces/set
- **Hexagon nut**
M5 DIN 934-8
8 pieces/set

* The length of the socket head cap bolt is dependent on the thickness of the attachment base.

For pivoting brackets choose 12
For locking brackets choose 34
Example: 15800-100- 34

Energy Chain System® E2 Tubes Series R157/R158 Mounting Brackets - KMA Abbreviated

energy chain® configurator 



R157
R158

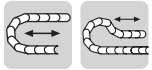

Standard

Option 1: KMA pivoting

- Extended, pivoting
- Easy to install
- Universal use
- Corrosion-resistant
- Long travels with lowered mounting height possible

Moving end
1580...1

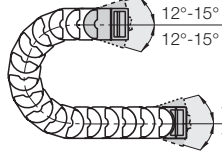

Fixed end
1580...2

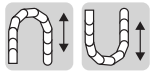
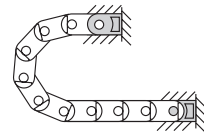

Option 2: KMA locking

- Extended, locking
- Easy to install
- Flush mounting at both ends of the Energy Tube
- Mounting points on all sides
- Corrosion resistant

Moving end
1585...1

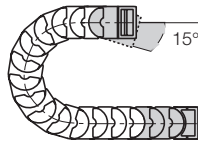

Fixed end
1585...2

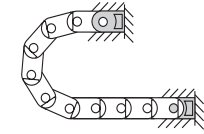

Part Number Structure

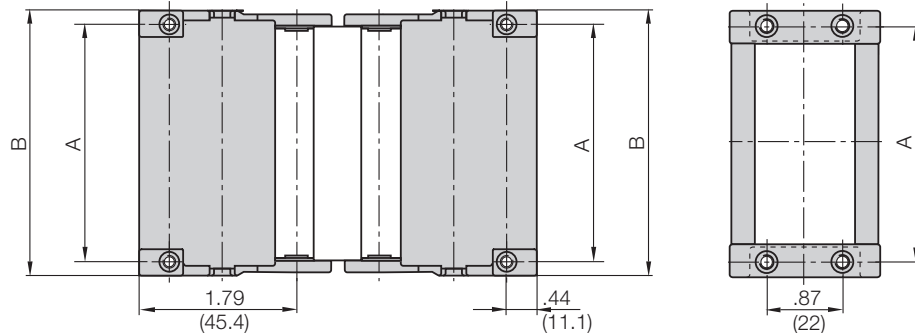
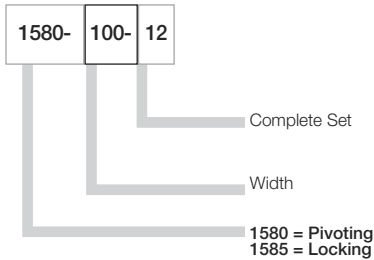

Part number examples are shown for pivoting brackets.
For locking brackets change part number to 1585

Full set, for both ends:

1580-100-12 Full set, each part with pin/bore

Single-part order:

1580-100-1 Mounting bracket with bore

1580-100-2 Mounting bracket with pin



Quickflange upon request

- Unassembled

Part number 16800-QF

Series	Part No. Full Set		Dimension A		Dimension B	
	Pivoting	Locking	in.	(mm)	in.	(mm)
157/158-040	1580-040-12	1585-040-12	1.97	(50)	2.40	(61)
157/158-050	1580-050-12	1585-050-12	2.40	(60)	2.80	(71)
157/158-075	1580-075-12	1585-075-12	3.35	(85)	3.78	(96)
157/158-088	1580-088-12	1585-088-12	3.86	(98)	4.29	(109)
157/158-090	1580-090-12	1585-090-12	3.86	(98)	4.29	(109)
157/158-100	1580-100-12	1585-100-12	4.33	(110)	4.76	(121)
157/158-125	1580-125-12	1585-125-12	5.31	(135)	5.75	(146)
157/158-135	1580-135-12	1585-135-12	5.71	(145)	6.14	(156)
157/158-150	1580-150-12	1585-150-12	6.30	(160)	6.73	(171)
157/158-175	1580-175-12	1585-175-12	7.28	(185)	7.72	(196)
157/158-200	1580-200-12	1585-200-12	8.27	(210)	8.70	(221)

The following parts are required for attachment of the mounting brackets:

- **Socket head cap bolt**
M5* DIN 912-8.8
8 pieces/set
- **Washer**
5.3 DIN 125-ST
8 pieces/set
- **Hexagon nut**
M5 DIN 934-8
8 pieces/set

* The length of the socket head cap bolt is dependent on the thickness of the attachment base.

PDF: www.igus.com/e-chain-pdfs
Specs/CAD/RFQ: www.igus.com/e-chains
RoHS info: www.igus.com/RoHS



Price Index



Series R167/R168

Special Features / Options



ESD classification:
Electrically conductive
ESD/ATEX version upon request



Flammability Class
VDE 0304 IIC UL94 HB

Assembly Tips

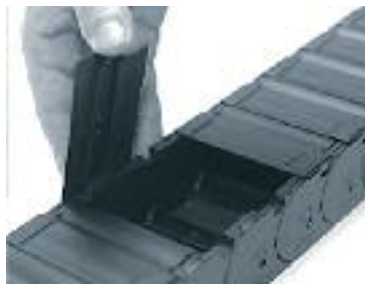

Lids of the Energy Tube Series R100 are hinged for easy access

Usage Guidelines



- If snap-open accessibility along inner **or** outer radius is required
- If a low-cost, lightweight Energy Tube for many types of applications is required
- If flush attachment is required
- If chip-repellent features are required



- If very smooth travel due to small pitch is required
➤ **Series R68 E2 Tubes**
- If snap-open accessibility along both radii simultaneously is required
➤ **Series R780 E4/100**

Features & Benefits

- 1 Lateral glide surfaces for side mounted operation
- 2 Snap-open lids along the inner and outer radius
- 3 Lids can be swiveled from the left to the right
- 4 Universal KMA mounting brackets with attachment capability on all sides
- 5 Double stop dog for strong unsupported length
- 6 Effective chip protection even against hot chips
- 7 Space-efficient with optimized ratio of inner dimension to outer dimension
- 8 Covered pin/bore connection

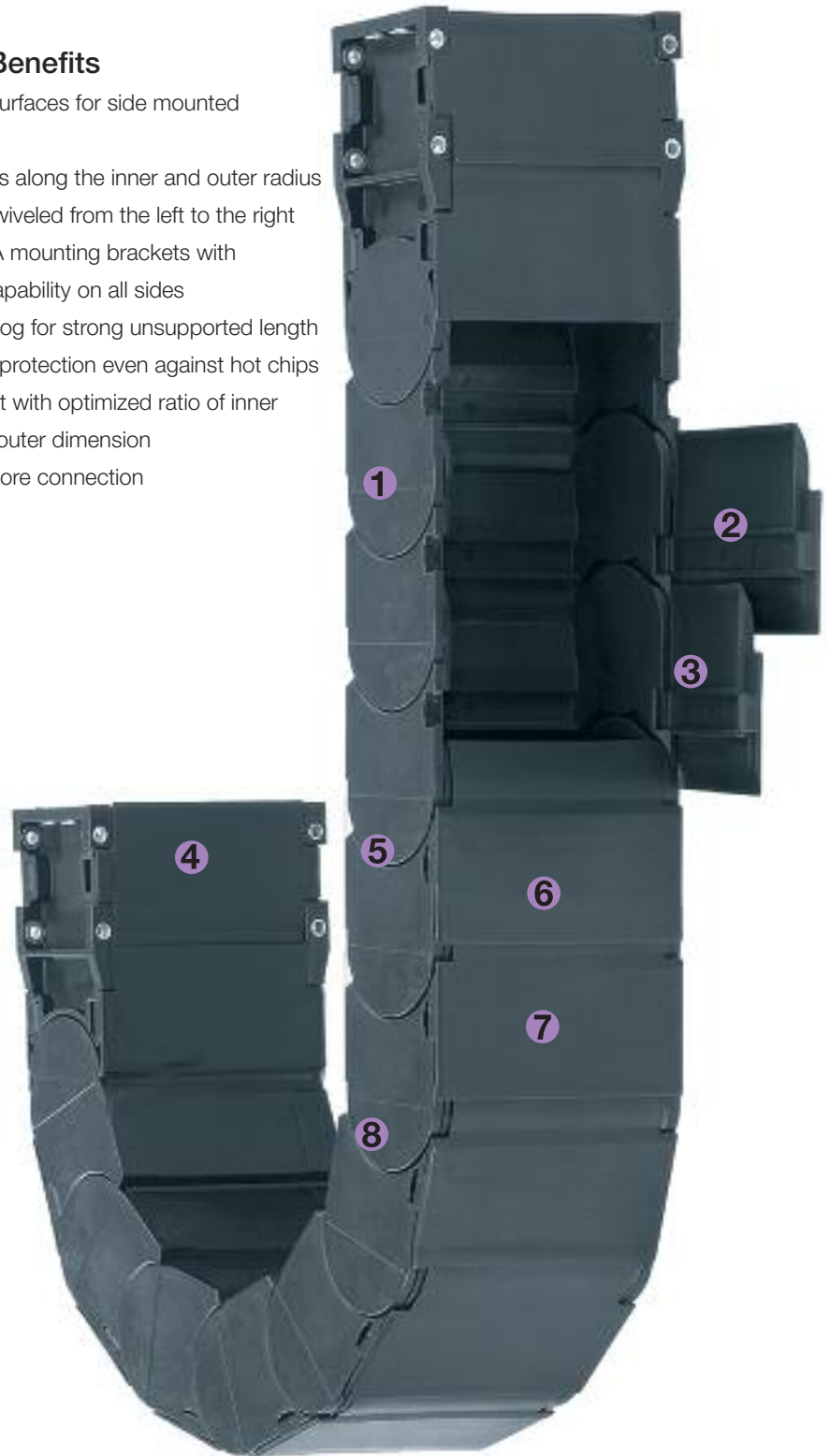

Order Example: Complete Energy Chain®

Please indicate chain length or number of links. Example:

energy chain® configurator ▶

3.28 ft (1 m) **167-100-100-0**



Energy Chain®

With 2 separators **1686-01** assembled every 2nd link



Interior Separation

1 Set **1680-100-12**



Mounting Bracket

Energy Chain System® E2 Tubes Series R167/R168 Installation Dimensions

energy chain® configurator ▶



R167
R168

Short travel, unsupported length

- FL_B = unsupported with permitted sag
 - FL_G = unsupported with straight upper run
- Further information ▶ Design, Chapter 1

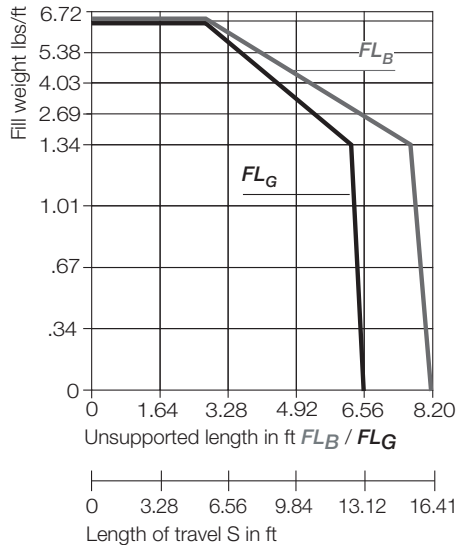
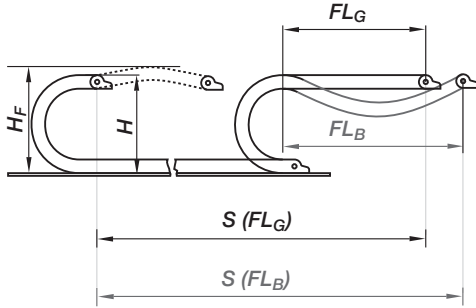

Short Travels - Unsupported



Unsupported Energy Chains® feature positive camber over short travels. This must be accounted for when specifying the clearance height. Please refer to **Installation dimensions** for further details.

Legend

- S = Length of travel
- R = Bending radius
- H = Nominal clearance height
- D = Overlength Energy Chain® radius in final position
- $K = \pi \cdot R + \text{safety buffer}$
- H_f = Required clearance height

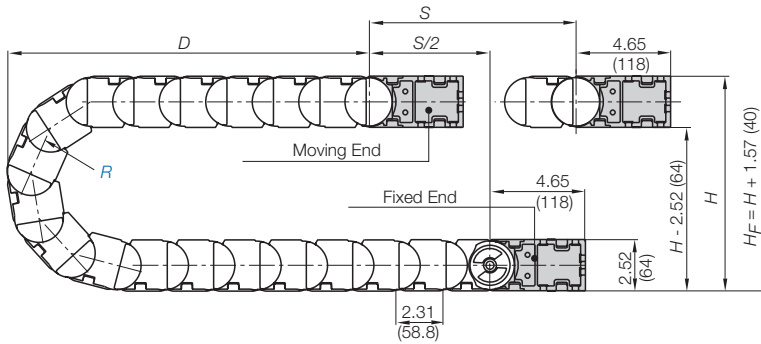

Pitch per link = 2.31" (58.8 mm)
Links per ft (m) = 5.18 (17)
For center mount applications:
Chain length = $\frac{S}{2} + K$

The required clearance height: $H_f = H + 1.57$ in. (40 mm) (with 1.34 lbs/ft (2.0 kg/m) fill weight. Please consult igus® if space is particularly restricted.

R	3.94 (100)	4.92 (125)	5.91 (150)	6.89 (175)	7.87 (200)	8.86 (225)	9.84 (250)	11.81 (300)
H	10.39 (264)	12.36 (314)	14.33 (364)	16.30 (414)	18.27 (464)	20.24 (514)	22.20 (564)	26.14 (664)
D	8.66 (220)	9.65 (245)	10.63 (270)	11.61 (295)	12.60 (320)	13.58 (345)	14.57 (370)	16.54 (420)
K	17.12 (435)	20.28 (515)	23.23 (590)	26.38 (670)	29.53 (750)	32.48 (825)	35.63 (905)	41.93 (1065)

PDF: www.igus.com/e-chain-pdfs
Specs/CAD/RFQ: www.igus.com/e-chains
RoHS info: www.igus.com/RoHS



Speed / acceleration FL_G	max. 32.8 ft/s (10 m/s) / max. 328 ft/s ² (100 m/s ²)
Speed / acceleration FL_B	max. 9.84 ft/s (3 m/s) / max. 19.69 ft/s ² (6 m/s ²)
Gliding speed / acceleration (maximum)	max. 1.64 ft/s (0.5 m/s) / max. 16.4 ft/s ² (5 m/s ²)
Material - permitted temperature	igumid G / -40°F (-40°C) up to +248°F (+120°C)
Flammability Class, igumid G	VDE 0304 IIC UL94 HB

Technical Data



Details of material properties

▶ Chapter 1

Series R167 - hinged, snap-open on both sides of the inner radius

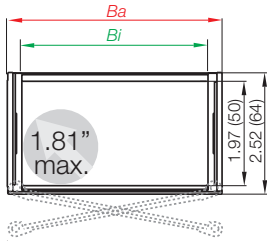

Part Number Structure



- Color - Black
- Bending radius
- Width
- Series

Series R168 - hinged, snap-open on both sides of the outer radius

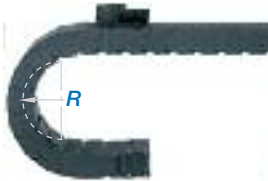
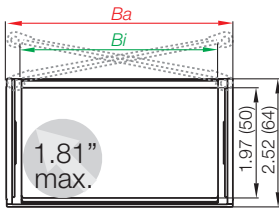

Part Number Structure



- Color - Black
- Bending radius
- Width
- Series

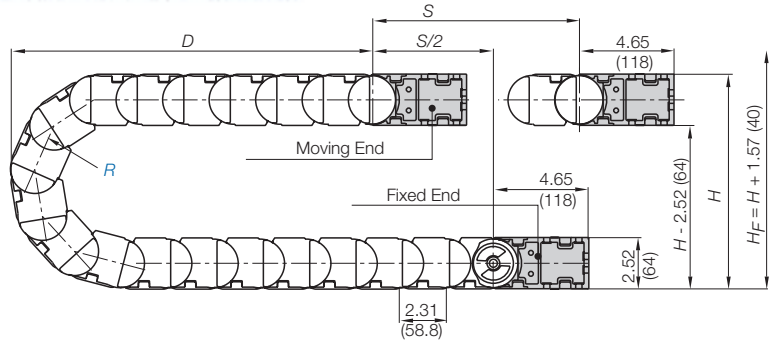

Supplement part number with required radius.
Example: 167-100-**100**-0
Pitch: 2.31 in. (58.8 mm) per link links/ft (m) = 5.18 (17)

Part Number.			<i>Bi</i>	<i>Ba</i>	Weight
Snap-open inner radius	Snap-open outer radius		in. (mm)	in. (mm)	lbs/ft (kg/m)
167-050-	168-050-	<input type="checkbox"/> -0	1.97 (50)	2.68 (68)	≈ 1.06 (1.58)
167-075-	168-075-	<input type="checkbox"/> -0	2.95 (75)	3.66 (93)	≈ 1.24 (1.84)
167-100-	168-100-	<input type="checkbox"/> -0	3.94 (100)	4.65 (118)	≈ 1.40 (2.09)
167-115-	168-115-	<input type="checkbox"/> -0	4.53 (115)	5.24 (133)	≈ 1.51 (2.24)
167-125-	168-125-	<input type="checkbox"/> -0	4.92 (125)	5.63 (143)	≈ 1.58 (2.35)
167-150-	168-150-	<input type="checkbox"/> -0	5.91 (150)	6.61 (168)	≈ 1.75 (2.60)
167-175-	168-175-	<input type="checkbox"/> -0	6.89 (175)	7.60 (193)	≈ 1.92 (2.86)
167-200-	168-200-	<input type="checkbox"/> -0	7.87 (200)	8.58 (218)	≈ 2.09 (3.11)
167-225-	168-225-	<input type="checkbox"/> -0	8.86 (225)	9.57 (243)	≈ 2.26 (3.37)
167-250-	168-250-	<input type="checkbox"/> -0	9.84 (250)	10.55 (268)	≈ 2.43 (3.62)

Choose from the radii below for all of the above sizes

Radius (mm) Example: 167-100-**100**-0

	100	125	150	175	200	225	250	300
R	3.94 (100)	4.92 (125)	5.91 (150)	6.89 (175)	7.87 (200)	8.86 (225)	9.84 (250)	11.81 (300)
H	10.39 (264)	12.36 (314)	14.33 (364)	16.30 (414)	18.27 (464)	20.24 (514)	22.20 (564)	26.14 (664)
D	8.66 (220)	9.65 (245)	10.63 (270)	11.61 (295)	12.60 (320)	13.58 (345)	14.57 (370)	16.54 (420)
K	17.12 (435)	20.28 (515)	23.23 (590)	26.38 (670)	29.53 (750)	32.48 (825)	35.63 (905)	41.93 (1065)

Energy Chain System® E2 Tubes

Series R167/R168

Interior Separation

energy chain® configurator



R167
R168

Option 1: Vertical separators

Vertical separators are used if a vertical subdivision of the Energy Tube interior is required. By standard, vertical separators are assembled every other Energy Tube link.

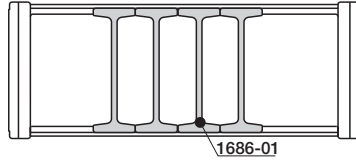

STANDARD

- **Standard separator 1685-01 for Energy Tubes**

This separator is used for general subdivision of Energy Tubes.



Vertical Separator

Unassembled **Part No. 1685-01**
Assembled **Part No. 1686-01**

Option 2: Full-width shelf

It is ideal for use in applications involving many thin cables with similar or identical diameters. This shelf slides into place and spans the entire width of the chain.

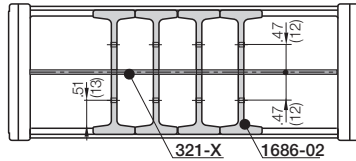

- **Slotted separator 1685-02 for Energy Tubes**

This component is used to form the basic pattern of a shelf system.

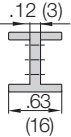

Vertical Separator, slotted

Unassembled **Part No. 1685-02**
Assembled **Part No. 1686-02**

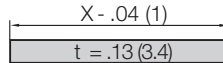

Shelves 220-XX

Shelves can be inserted at 3 different heights in .20" (5mm) increments

Width X	Part No.	Part No.
in. (mm)	Unassembled	Assembled
.98 (25)	320-050	321-050
1.50 (38)	320-075	321-075
2.24 (57)	320-100	321-100
3.03 (77)	320-115	321-115
3.54 (90)	320-125	321-125
4.06 (103)	320-150	321-150
4.92 (125)	320-175	321-175
4.92 (125)	320-200	321-200
4.92 (125)	320-225	321-225
4.92 (125)	320-250	321-250

Option 3: Shelves

It is ideal for use in applications involving many cables with similar or identical diameters. Partial separation into individual compartments can be achieved and can be used across the entire width.

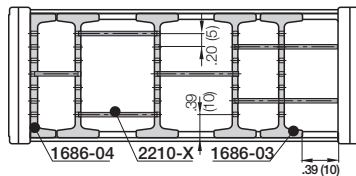

- **Slotted separator 1685-03 for Energy Tubes**

This component is used to form the basic pattern of a shelf system.



Vertical Separator, slotted

Unassembled **Part No. 1685-03**
Assembled **Part No. 1686-03**

- **Side plate 1685-04 for Energy Tubes**

This component is used to form the basic pattern of a shelf system.

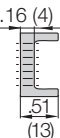

Side Plate

Unassembled **Part No. 1685-04**
Assembled **Part No. 1686-04**

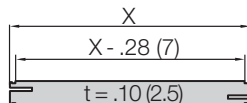

Shelves 2200-XX

These components form the basic pattern of a shelf system. Shelves of various widths can be arranged at 7 different heights in .20" (5mm) increments

Width X	Part No.	Part No.
in. (mm)	Unassembled	Assembled
.71 (18)	2200-18	2210-18
.91 (23)	2200-23	2210-23
1.10 (28)	2200-28	2210-28
1.30 (33)	2200-33	2210-33
1.50 (38)	2200-38	2210-38
1.69 (43)	2200-43	2210-43
1.89 (48)	2200-48	2210-48
2.28 (58)	2200-58	2210-58
2.68 (68)	2200-68	2210-68
2.87 (73)	2200-73	2210-73
3.46 (88)	2200-88	2210-88
3.90 (99)	2200-99	2210-99
4.88 (124)	2200-124	2210-124
5.87 (149)	2200-149	2210-149

PDF: www.igus.com/e-chain-pdfs
Specs/CAD/RFQ: www.igus.com/e-chains
RoHS info: www.igus.com/RoHS





Option 1: pivoting

- Unsupported and gliding applications
- Mounting points on all sides
- Quickflange Option, bolted outside of Energy Tube cross section
- Long travels with lowered mounting height possible
- Corrosion-resistant

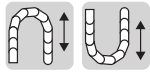

Option 2: locking

- Vertical hanging/standing applications
- Quickflange Option, bolted outside of Energy Tube cross section
- Extreme speeds and accelerations
- Mounting points on all sides
- Flush mounting at both ends of the Energy Tube



Part Number Structure

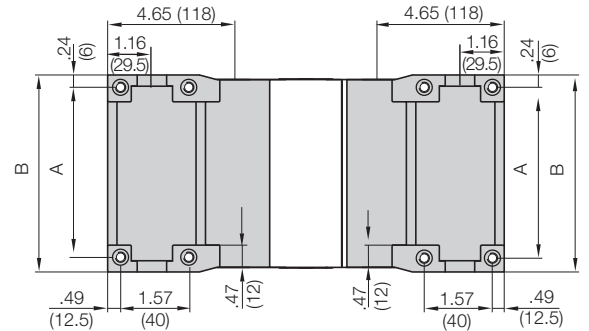
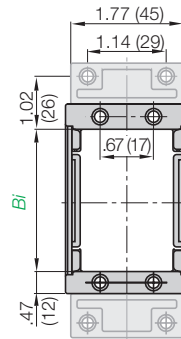
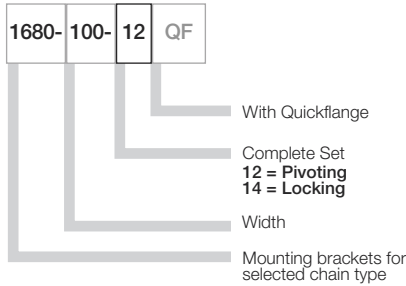

Full set, for both ends:

1680-100-12-QF Full set, each part with pin/bore + tiewrap plate

Single-part order:

1680-100-1-QF Mounting bracket with bore + tiewrap plate

1680-100-2-QF Mounting bracket with pin + tiewrap plate



Quickflange Unassembled
Part number 16800-QF

For Tube Type	Part No. Full set with Tiewrap Plate	Part No. Full Set with Quickflange	Dimension A in. (mm)	Dimension B in. (mm)
167/168-050	1680-050- <input type="checkbox"/>	1680-050- <input type="checkbox"/> QF	2.44 (62)	2.91 (74)
167/168-075	1680-075- <input type="checkbox"/>	1680-075- <input type="checkbox"/> QF	3.43 (87)	3.90 (99)
167/168-100	1680-100- <input type="checkbox"/>	1680-100- <input type="checkbox"/> QF	4.41 (112)	4.88 (124)
167/168-115	1680-115- <input type="checkbox"/>	1680-115- <input type="checkbox"/> QF	5.00 (127)	5.47 (139)
167/168-125	1680-125- <input type="checkbox"/>	1680-125- <input type="checkbox"/> QF	5.39 (137)	5.87 (149)
167/168-150	1680-150- <input type="checkbox"/>	1680-150- <input type="checkbox"/> QF	6.38 (162)	6.85 (174)
167/168-175	1680-175- <input type="checkbox"/>	1680-175- <input type="checkbox"/> QF	7.36 (187)	7.83 (199)
167/168-200	1680-200- <input type="checkbox"/>	1680-200- <input type="checkbox"/> QF	8.35 (212)	8.82 (224)
167/168-225	1680-225- <input type="checkbox"/>	1680-225- <input type="checkbox"/> QF	9.33 (237)	9.80 (249)
167/168-250	1680-250- <input type="checkbox"/>	1680-250- <input type="checkbox"/> QF	10.31 (262)	10.79 (274)

For pivoting brackets choose 12
For locking brackets choose 14
Example: 1680-100- 14 QF

The following parts are required for attachment of the mounting brackets:

- **Socket head cap bolt**
M5* DIN 912-8.8
8 pieces/set
- **Washer**
5.3 DIN 125-ST
8 pieces/set
- **Hexagon nut**
M5 DIN 934-8
8 pieces/set

* The length of the socket head cap bolt is dependent on the thickness of the attachment base.

PDF: www.igus.com/e-chain-pdfs
Specs/CAD/RFQ: www.igus.com/e-chains
RoHS info: www.igus.com/RoHS



Price Index

Series 1480

Special Features / Options

IPA Qualification Certificate
Air Cleanliness Class ISO Class 3
(at $v = 6.56$ ft/s) upon request



ESD classification:
Electrically conductive
ESD/ATEX version upon request



Flammability Class
VDE 0304 IIC UL94 HB

Assembly Tips

Insert screwdriver into the slot, using a lever action apply pressure to the screwdriver to release

Other Installation Methods

Vertical, hanging ≤ 65.6 ft (20 m)

Vertical, standing ≤ 6.56 ft (2 m)

Side-mounted, un_supp. ≤ 2.3 ft (0.7 m)

Rotary requires further calculation

Usage Guidelines



- If hinged, snap-open accessibility along the inner radius is required
- If integrated strain relief is required at the connection point
- If long service life is required
- If chip protection is required
- If easy installation is required



- If the application is very simple
➤ **Series R117 E2 Tubes**

Features & Benefits

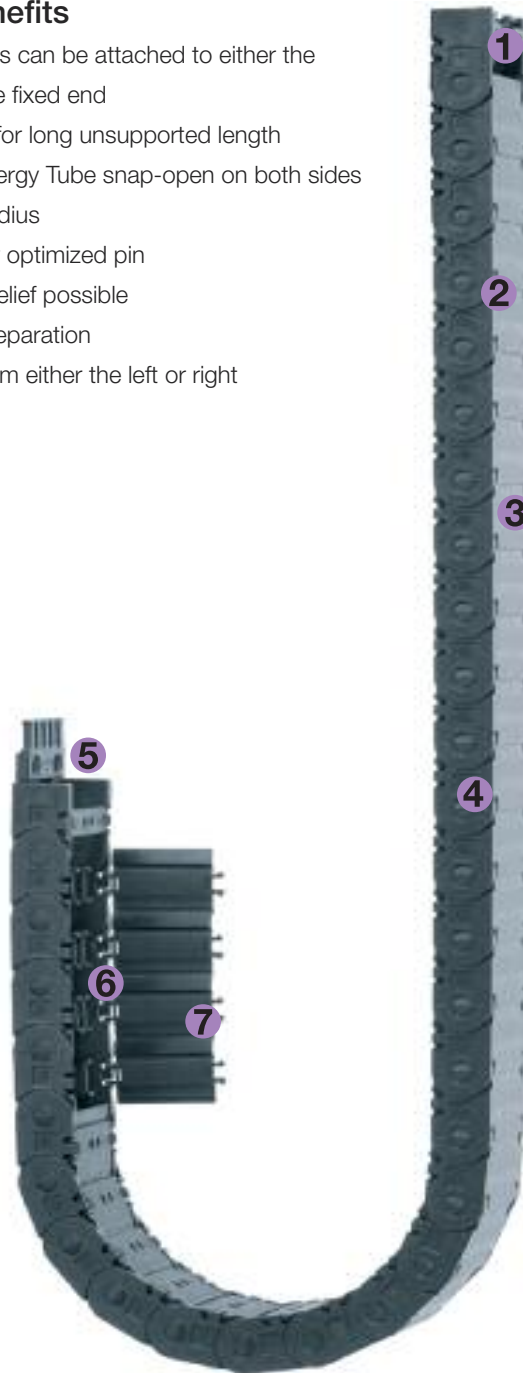
- 1 Mounting brackets can be attached to either the moving end or the fixed end
- 2 Double stop dog for long unsupported length
- 3 Fully enclosed Energy Tube snap-open on both sides along the inner radius
- 4 Easy assembly by optimized pin
- 5 Integrated strain relief possible
- 6 Modular interior separation
- 7 Rapid opening from either the left or right

Order Example: Complete Energy Chain®

Please indicate chain length or number of links. Example:

energy chain® configurator

3.28 ft (1 m) **1480-038-075-0**



Energy Chain®

With 2 separators **14501** assembled every 2nd link



Interior Separation

1 Set **15000-038-34PZB**



Mounting Bracket

Energy Chain System® E2 Tubes Series R1480 Installation Dimensions

energy chain® configurator



R1480

Short travel, unsupported length

- FL_B = unsupported with permitted sag
 - FL_G = unsupported with straight upper run
- Further information Design, Chapter 1

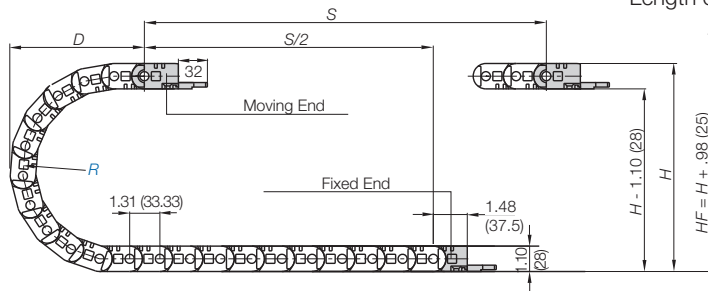
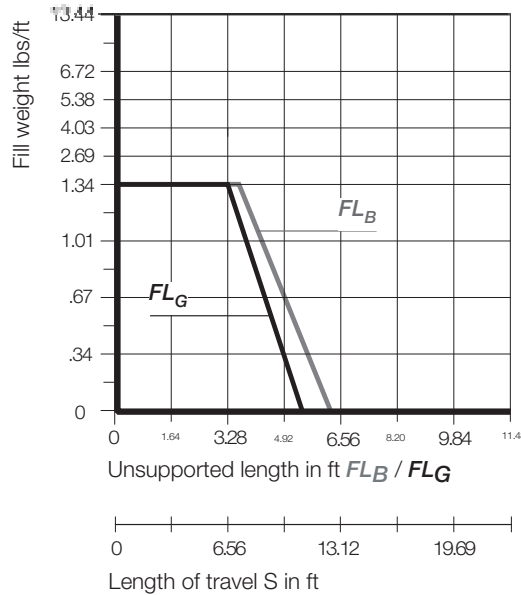
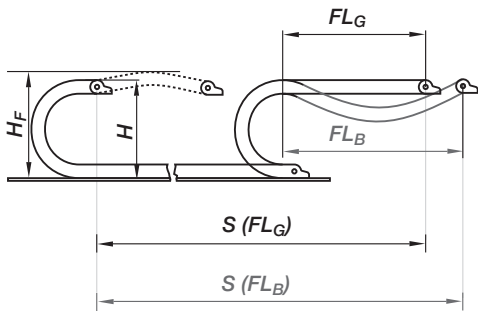

Pitch per link = 1.31" (33 mm)
Links per ft (m) = 9.41 (30)
For center mount applications:
Chain length = $\frac{S}{2} + K$

The required clearance height: $H_F = H + .98$ in. (25 mm) (with .34 lbs/ft (0.5 kg/m) fill weight).
Please consult igus® if space is particularly restricted.

R	2.95 (075)	3.94 (100)	4.92 (125)	5.71 (145)	7.09 (180)
H	7.01 (178)	8.98 (228)	10.94 (278)	12.52 (318)	15.28 (388)
D	5.47 (139)	6.46 (164)	7.44 (189)	8.23 (209)	9.61 (244)
K	12.01 (305)	15.16 (385)	18.11 (460)	20.67 (525)	25.00 (635)

Short Travels - Unsupported

Unsupported Energy Chains® feature positive camber over short travels. This must be accounted for when specifying the clearance height. Please refer to **Installation dimensions** for further details.

Legend

- S = Length of travel
- R = Bending radius
- H = Nominal clearance height
- D = Overlength Energy Chain® radius in final position
- $K = \pi \cdot R + \text{safety buffer}$
- H_F = Required clearance height
- H_{R1} = Trough inner height
- H_2 = *Mounting height
- D_2 = Overlength - long travels, gliding
- K_2 = *Add-on
- *If the mounting bracket location is set lower



PDF: www.igus.com/e-chain-pdfs
Specs/CAD/RFQ: www.igus.com/e-chains
RoHS info: www.igus.com/RoHS

For long travels with lowered mounting height

Long travel lengths from 32.8 ft. (10 m) to max. 246 ft. (75 m)

For center mount applications:
Chain length = $\frac{S}{2} + K_2$

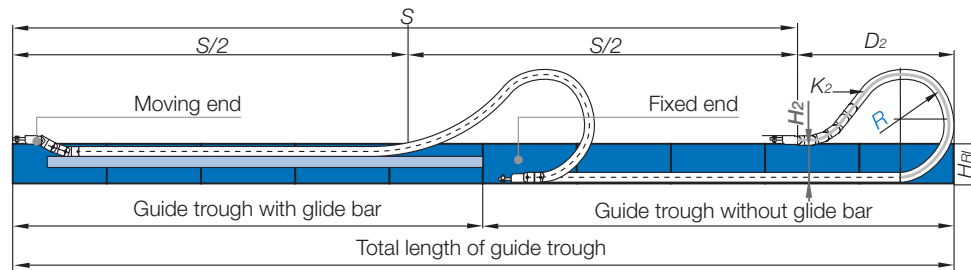

R	6.89 (075)	7.87 (100)	8.86 (125)	9.84 (145)	11.81 (180)
H_2	-	3.94 (100)	3.94 (100)	3.94 (100)	3.94 (100)
D_2^{*25}	-	13.39 (340)	19.49 (495)	21.26 (540)	27.17 (690)
K_2	-	23.62 (600)	31.50 (800)	37.01 (940)	46.06 (1170)

Long Travels - Gliding

If the unsupported length is exceeded, the Energy Chain®/Tube must glide on itself. This requires a guide trough.
Design, Chapter 1

Speed / acceleration FL_G	max. 65.6 ft/s (20 m/s) / max. 656 ft/s ² (200 m/s ²)
Speed / acceleration FL_B	max. 9.84 ft/s (3 m/s) / max. 19.69 ft/s ² (6 m/s ²)
Material - permitted temperature	igumid G / -40°F (-40°C) up to +248°F (+120°C)
Flammability Class, igumid G	VDE 0304 IIC UL94 HB

Technical Data



Details of material properties
 Chapter 1

igus® Energy Chain System®

Series R1480 - hinged, snap-open along the inner radius

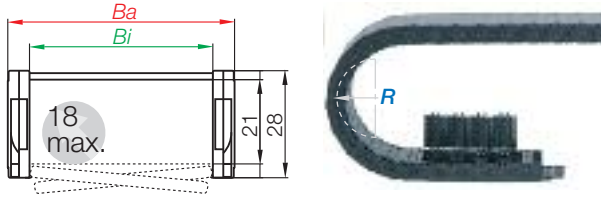

Part Number Structure

1480-038-075-0

- Color - Black
- Bending radius
- Width
- Series

Telephone 1-800-521-2747
Fax 1-401-438-7270

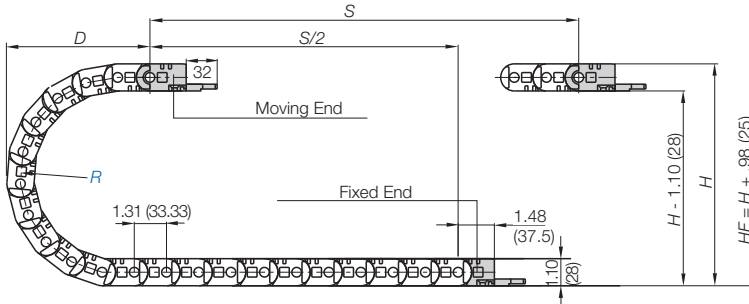

Supplement part number with required radius. Example: 1480-038--0
Pitch: 1.31 in. (33 mm) per link links/ft(m) = 9.41 (30)

Part Number.

Snap-open inner radius	Bi in. (mm)	Ba in. (mm)	Weight lbs/ft (kg/m)
1480-015- <input type="text" value="075"/> -0	.79 (15)	1.12 (28.5)	≈ 0.32 (0.48)
1480-025- <input type="text" value="075"/> -0	.98 (25)	1.52 (38.5)	≈ 0.36 (0.54)
1480-038- <input type="text" value="075"/> -0	1.50 (38)	2.03 (51.5)	≈ 0.41 (0.61)
1480-050- <input type="text" value="075"/> -0	1.97 (50)	2.50 (63.5)	≈ 0.45 (0.67)
1480-068- <input type="text" value="075"/> -0	2.68 (68)	3.21 (81.5)	≈ 0.52 (0.77)
1480-080- <input type="text" value="075"/> -0	3.15 (80)	3.68 (93.5)	≈ 0.56 (0.84)
1480-100- <input type="text" value="075"/> -0	3.94 (100)	4.47 (113.5)	≈ 0.64 (0.95)
1480-125- <input type="text" value="075"/> -0	3.94 (125)	5.45 (138.5)	≈ 0.73 (1.08)

Choose from the radii below for all of the above sizes

Radius (mm) Example: 1480-038--0

	075	100	125	145	180
R	2.95 (075)	3.94 (100)	4.92 (125)	5.71 (145)	7.09 (180)
H	7.01 (178)	8.98 (228)	10.94 (278)	12.52 (318)	15.28 (388)
D	5.47 (139)	6.46 (164)	7.44 (189)	8.23 (209)	9.61 (244)
K	12.01 (305)	15.16 (385)	18.11 (460)	20.67 (525)	25.00 (635)

Internet: <http://www.igus.com>
email: sales@igus.com
QuickSpec: <http://www.igus.com/quickspec>

Energy Chain System® E2 Tubes

Series R1480

Interior Separation

energy chain® configurator 



R1480

Option 1: Vertical separators

Vertical separators are used if a vertical subdivision of the Energy Tube interior is required. By standard, vertical separators are assembled every other Energy Tube link.

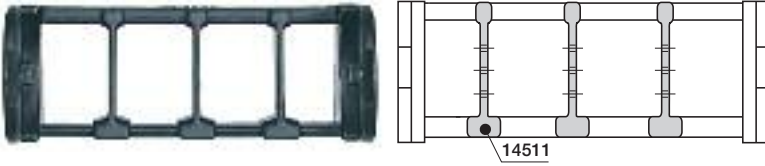

- **Standard separator 14501 for Energy Tubes**

This separator is used for general subdivision of Energy Tubes.



Option 2: Full-width shelf

It is ideal for use in applications involving many thin cables with similar or identical diameters. This shelf slides into place and spans the entire width of the chain.

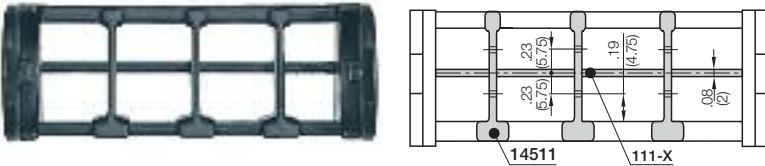

Shelves 110-XX

Shelves can be inserted at 3 different heights in .20" (5mm) increments

Width X in. (mm)	Part No. Unassembled	Part No. Assembled
1.57 (15)	110-15	111-15
1.97 (20)	110-20	111-20
2.95 (25)	110-25	111-25
3.46 (38)	110-38	111-38
3.94 (50)	110-50	111-50
4.92 (68)	110-68	111-68
5.31 (80)	110-80	111-80
5.91 (100)	110-100	111-100
6.89 (125)	110-125	111-125

PDF: www.igus.com/e-chain-pdfs
 Specs/CAD/RFG: www.igus.com/e-chains
 RoHS info: www.igus.com/RoHS



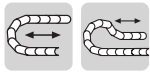

Moving end
15000...3PZ(B)

Option 1: pivoting

- For unsupported applications
- Well suited for tight installation conditions
- Detachable strain relief tiwrap plates
- Can be mounted on the fixed and/or moving end

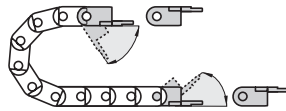

Fixed end
15000...4PZ(B)

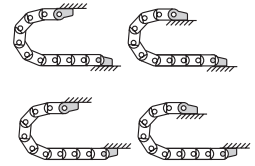

Possible installation configurations -

Part Number Structure

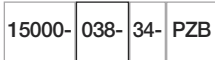

- 15000- With tiwrap plate
- 038- Complete Set
34 = Pivoting
- 34- Width
- PZB- Mounting brackets for selected chain type

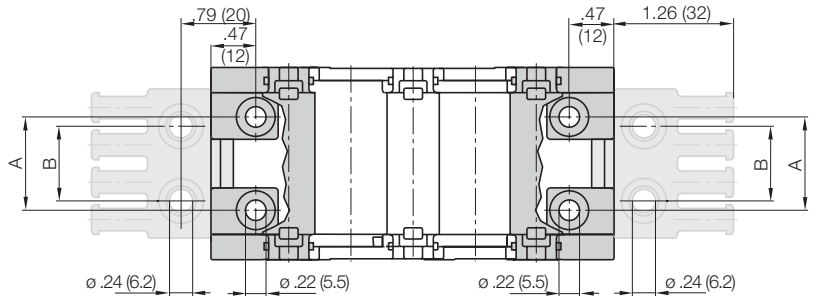

Full set, for both ends:

15000-038-34 Full set, each part with pin/bore

Single-part order:

- 15000-038-3 Mounting bracket with bore
- 15000-038-4 Mounting bracket with pin

Part No. Mounting Brackets Full Set

4 parts, 2 with pin, 2 with bore
Series 1480:
15000-Width-34

Part No. Mounting bracket with bore

2 parts, 1 left & 1 right
Series 1480:
15000-Width-1

Part No. Mounting bracket with pin

2 parts, 1 left & 1 right
Series 1480:
15000-Width-4

For Series	Part No.		Dimension A		Dimension B	
	Full Set without Tiwrap Plate	Full Set with Tiwrap Plate	in.	(mm)	in.	(mm)
1480-015	-	-	-	-	-	-
1480-020	-	-	-	-	-	-
1480-025	15000-025-34PZ	15000-025-34PZB	.47	(12)	.59	(15)
1480-038	15000-038-34PZ	15000-038-34PZB	.98	(25)	.79	(20)
1480-050	15000-050-34PZ	15000-050-34PZB	1.46	(37)	1.18	(30)
1480-068	15000-068-34PZ	15000-068-34PZB	2.17	(55)	1.57	(40)
1480-080	15000-080-34PZ	15000-080-34PZB	2.64	(67)	2.36	(60)
1480-100	15000-100-34PZ	15000-100-34PZB	3.43	(87)	3.15	(80)
1480-125	15000-125-34PZ	15000-125-34PZB	4.41	(112)	4.13	(105)

Energy Chain System® E2 Tubes Series R1480 Mounting Bracket - Steel

energy chain® configurator ▶



R1480



Option 2: Steel

- Locked connections
- One part (two-piece) for all chain widths
- Electrically conductive
- Bolted connection outside of chain cross-section possible

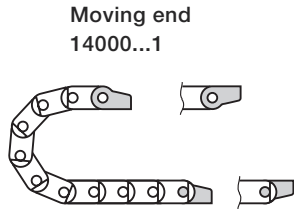

Moving end
14000...1



Fixed end
14000...2

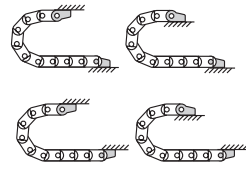

Possible installation configurations -

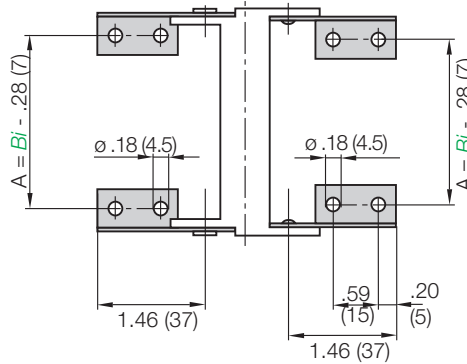
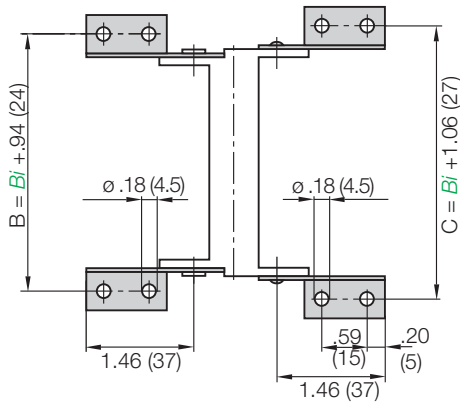

Chain Type	Part No. Full Set	Dimension A		Dimension B		Dimension C	
		in.	(mm)	in.	(mm)	in.	(mm)
1480-015	14000-12	.31	(8)	1.54	(39)	1.65	(42)
1480-020	14000-12	.51	(13)	1.73	(44)	1.85	(47)
1480-025	14000-12	.71	(18)	1.93	(49)	2.05	(52)
1480-038	14000-12	1.22	(31)	2.44	(62)	2.56	(65)
1480-050	14000-12	1.69	(43)	2.91	(74)	3.03	(77)
1480-068	14000-12	2.40	(61)	3.62	(92)	3.74	(95)
1480-080	14000-12	2.87	(73)	4.09	(104)	4.21	(107)
1480-100	14000-12	3.66	(93)	4.88	(124)	5.00	(127)
1480-125	14000-12	4.65	(118)	5.87	(149)	5.98	(152)

Part No. Mounting Brackets Full Set

4 parts, 2 with pin, 2 with bore
Series 1480:
14000-12

Part No. Mounting Bracket Moving End

2 parts, 1 left & 1 right
Series 1480:
14000-1

Part No. Mounting Bracket Fixed End

2 parts, 1 left & 1 right
Series 1480:
14000-2

PDF: www.igus.com/e-chain-pdfs
Specs/CAD/RFQ: www.igus.com/e-chains
RoHS info: www.igus.com/RoHS



Tiewrap Plates

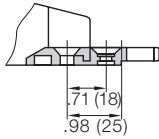

Shown assembled

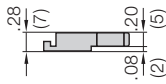

Single tiewrap plate



Option 1:

Tiewrap plates as an individual part

Available as an individual component, can be fixed onto a mounting bracket with the use of a profile rail.

Tiewrap Plates	n Number of Teeth	Dimension C	Dimension B
2020-ZB	3	1.18 (30)	.59 (15)
2030-ZB	4	1.57 (40)	.79 (20)
2040-ZB	5	1.97 (50)	1.18 (30)
2050-ZB	6	2.36 (60)	1.57 (40)
2070-ZB	8	3.15 (80)	2.36 (60)
2090-ZB	9	3.54 (90)	2.76 (70)
2100-ZB	10	3.94 (100)	3.15 (80)
2125-ZB	12	4.72 (120)	3.94 (100)

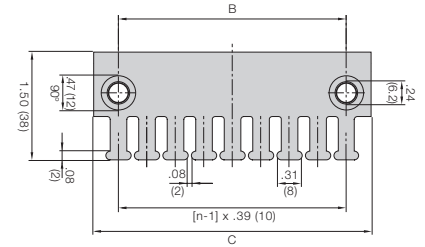

For more information please refer to strain relief section of Chapter 10

Cable tiewraps as individual parts

Cable tiewraps 100 pieces/bag	Width x Length		Maximum Ø		Tensile Strength	
	in.	(mm)	in.	(mm)	lbs	(N)
CFB-001	.19 x 5.91	(4.8 x 150)	1.42	(36)	50	(222)

Strain relief for steel mounting brackets

Clip-on connection is not possible with steel mounting brackets. In this case, the tiewrap plates must be bolted directly into separate bore holes in front of the mounting bracket. Alternatively the tiewrap plates **20XX-ZB** can be also used here. **Details chapter 10**

PDF: www.igus.com/e-chain-pdfs
Specs/CAD/RFQ: www.igus.com/e-chains
RoHS info: www.igus.com/RoHS



Price Index

Series 2480

Special Features / Options

IPA Qualification Certificate
Air Cleanliness Class ISO Class 3
(at v = 6.56 ft/s) upon request



ESD classification:
Electrically conductive
ESD/ATEX version upon request



Flammability Class
VDE 0304 IIC UL94 HB

Assembly Tips

Insert screwdriver into the slot, using a lever action apply pressure to the screwdriver to release

Other Installation Methods

Vertical, hanging ≤ 131 ft (40 m)

Vertical, standing ≤ 9.84 ft (3 m)

Side-mounted, un_supp. ≤ 3.28 ft (1 m)

Rotary requires further calculation

Usage Guidelines

- If hinged, snap-open accessibility along the inner radius is required
- If integrated strain relief is required at the connection point
- If long service life is required
- If chip protection is required
- If easy installation is required



- If particularly quiet operation is required
➤ **Series R58 E2 Tubes**
- If snap-open accessibility along both radii is required
➤ **Series R770 E4/100**

Features & Benefits

- 1 Double stop dog for long unsupported length
- 2 Lateral glide surfaces for side-mounted operation
- 3 Integrated strain relief possible
- 4 Fully enclosed Energy Tube snap-open on both sides along the inner radius
- 5 Modular interior separation
- 6 Easy assembly by optimized pin
- 7 Rapid opening from either the left or right

Order Example: Complete Energy Chain®

Please indicate chain length or number of links. Example:

energy chain® configurator

9.84 ft (3 m) **2480-10-100-0**



Energy Chain®

With 2 separators **24501** assembled every 2nd link



Interior Separation

1 Set **2100-34PZB+**



Mounting Bracket

Energy Chain System® E2 Tubes Series R2480 Installation Dimensions

energy chain® configurator



R2480

Short travel, unsupported length

- FL_B = unsupported with permitted sag
 - FL_G = unsupported with straight upper run
- Further information ► Design, Chapter 1

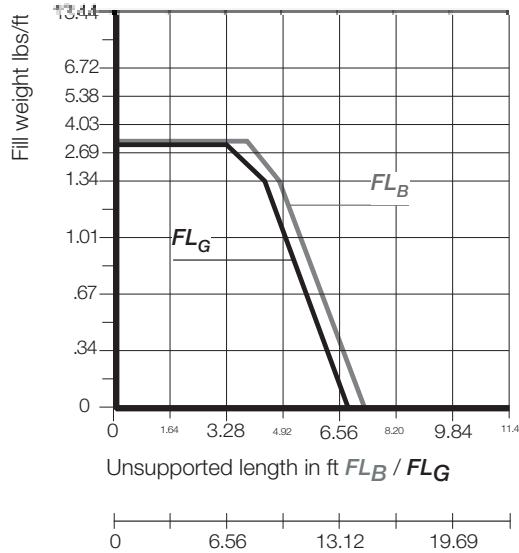
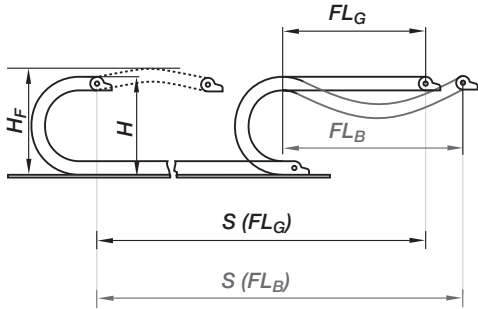

Short Travels - Unsupported



Unsupported Energy Chains® feature positive camber over short travels. This must be accounted for when specifying the clearance height. Please refer to **Installation dimensions** for further details.

Legend

- S = Length of travel
- R = Bending radius
- H = Nominal clearance height
- D = Overlength Energy Chain® radius in final position
- $K = \pi \cdot R + \text{safety buffer}$
- H_F = Required clearance height
- H_{R1} = Trough inner height
- H_2 = *Mounting height
- D_2 = Overlength - long travels, gliding
- K_2 = *Add-on
- *If the mounting bracket location is set lower

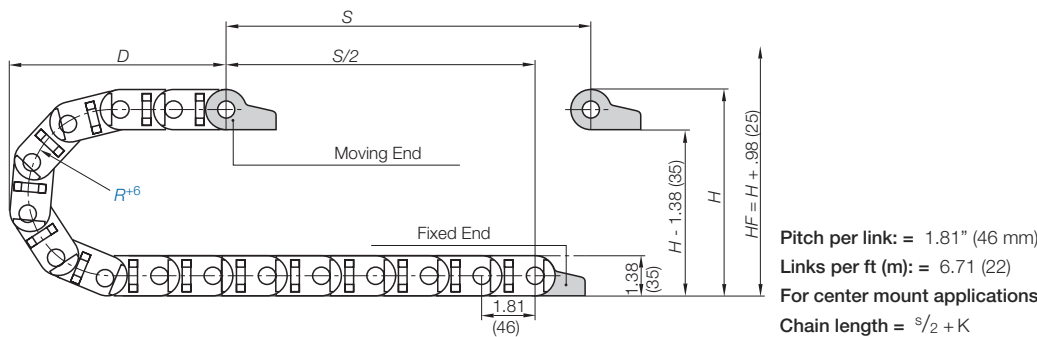

The required clearance height: $H_F = H + .98$ in. (25 mm) (with 1.01 lbs/ft (1.5 kg/m) fill weight). Please consult igus® if space is particularly restricted.

R	1.38 (055*)	1.50 (075)	3.94 (100)	4.92 (125)	5.91 (150)	6.89 (175)	7.87 (200)	8.86 (225)	9.84 (250)
H	5.71 (145)	7.28 (185)	9.25 (235)	11.22 (285)	13.19 (335)	15.16 (385)	17.13 (435)	19.09 (485)	21.06 (535)
D	5.59 (142)	6.38 (162)	7.36 (187)	8.35 (212)	9.33 (237)	10.31 (262)	11.30 (287)	12.28 (312)	13.27 (337)
K	10.43 (265)	12.99 (330)	16.14 (410)	19.09 (485)	22.24 (565)	25.39 (645)	28.54 (725)	31.50 (800)	34.65 (880)

*upon request

For long travels with lowered mounting height

Long travel lengths from 32.8 ft. (10 m) to max. 328 ft. (100 m)

For center mount applications:
Chain length = $S/2 + K_2$

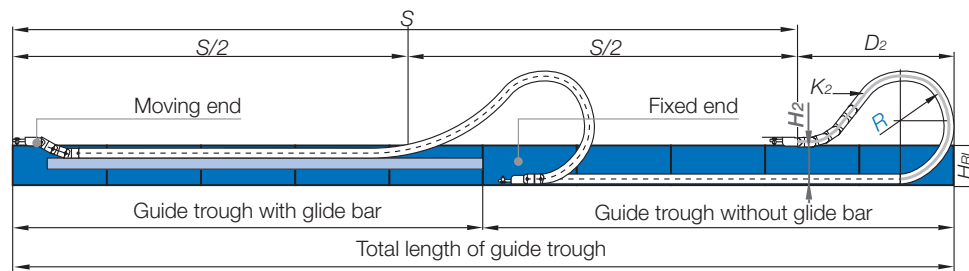

Long Travels - Gliding



If the unsupported length is exceeded, the Energy Chain®/Tube must glide on itself. This requires a guide trough.

Design, Chapter 1

R	1.38 (055*)	1.50 (075)	3.94 (100)	4.92 (125)	5.91 (150)	6.89 (175)	7.87 (200)	8.86 (225)	9.84 (250)
H_2	4.33 (110)	5.91 (150)	3.94 (100)	3.94 (100)	3.94 (100)	3.94 (100)	3.94 (100)	3.94 (100)	3.94 (100)
D_2^{*25}	5.59 (142)	6.38 (162)	14.96 (380)	17.32 (440)	23.23 (590)	29.72 (755)	37.40 (950)	40.94 (1040)	44.49 (1130)
K_2	10.43 (265)	12.99 (330)	25.35 (644)	28.98 (736)	39.84 (1012)	48.90 (1242)	57.95 (1472)	63.39 (1610)	70.63 (1794)

*upon request

Speed / acceleration FL_G	max. 65.6 ft/s (20 m/s) / max. 656 ft/s ² (200 m/s ²)
Speed / acceleration FL_B	max. 9.84 ft/s (3 m/s) / max. 19.69 ft/s ² (6 m/s ²)
Gliding speed / acceleration (maximum)	max. 32.8 ft/s (10 m/s) / max. 164 ft/s ² (50 m/s ²)
Material - permitted temperature	igumid G / -40°F (-40°C) up to +248°F (+120°C)
Flammability Class, igumid G	VDE 0304 IIC UL94 HB

Technical Data



Details of material properties

► Chapter 1

PDF: www.igus.com/e-chain-pdfs
Specs/CAD/RFQ: www.igus.com/e-chains
RoHS info: www.igus.com/RoHS



Series R2480 - hinged, snap-open along the inner radius

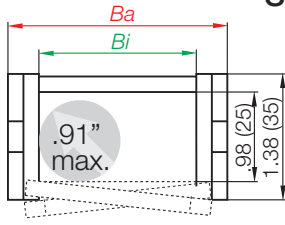

Part Number Structure



- Color - Black
- Bending radius
- Width
- Series

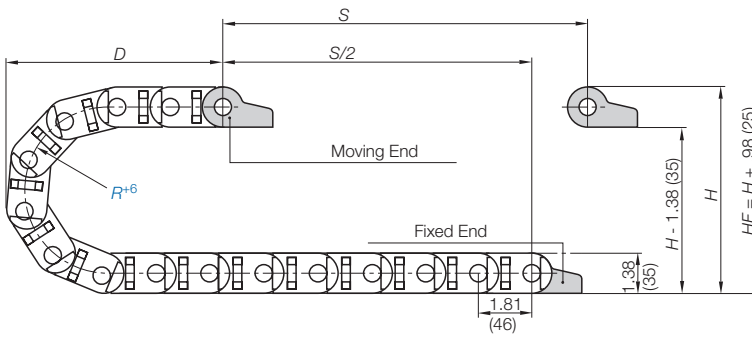

Supplement part number with required radius. Example: 2480-10-**100**-0
Pitch: 1.81 in. (46 mm) per link links/ft(m) = 6.71 (22)

Part Number.

Snap-open inner radius	Bi in. (mm)	Ba in. (mm)	Weight lbs/ft (kg/m)
2480-02- <input type="checkbox"/> -0	.98 (25)	1.61 (41)	≈ 0.55 (0.82)
2480-03- <input type="checkbox"/> -0	1.50 (38)	2.13 (54)	≈ 0.62 (0.92)
2480-05- <input type="checkbox"/> -0	2.24 (57)	2.87 (73)	≈ 0.69 (1.03)
2480-07- <input type="checkbox"/> -0	3.03 (77)	3.66 (93)	≈ 0.79 (1.17)
2480-09- <input type="checkbox"/> -0	3.50 (89)	4.13 (105)	≈ 0.85 (1.26)
2480-10- <input type="checkbox"/> -0	4.06 (103)	4.69 (119)	≈ 0.90 (1.34)
2480-12- <input type="checkbox"/> -0	4.92 (125)	5.55 (141)	≈ 0.96 (1.43)

Choose from the radii below for all of the above sizes

Radius (mm) Example: 2480-10-**100**-0

	055*	075	100	125	150	175	200	225	250
R	1.38 (055*)	1.50 (075*)	3.94 (100)	4.92 (125)	5.91 (150)	6.89 (175)	7.87 (200)	8.86 (225)	9.84 (250)
H	5.71 (145)	7.28 (185)	9.25 (235)	11.22 (285)	13.19 (335)	15.16 (385)	17.13 (435)	19.09 (485)	21.06 (535)
D	5.59 (142)	6.38 (162)	7.36 (187)	8.35 (212)	9.33 (237)	10.31 (262)	11.30 (287)	12.28 (312)	13.27 (337)
K	10.43 (265)	12.99 (330)	16.14 (410)	19.09 (485)	22.24 (565)	25.39 (645)	28.54 (725)	31.50 (800)	34.65 (880)

Energy Chain System® E2 Tubes

Series R2480

Interior Separation

energy chain® configurator ▶



R2480

Option 1: Vertical separators

Vertical separators are used if a vertical subdivision of the Energy Tube interior is required. By standard, vertical separators are assembled every other Energy Tube link.



- **Standard separator 24501 for Energy Tubes**

This separator is used for general subdivision of Energy Tubes.

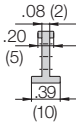

Vertical Separator

Unassembled **Part No. 24501**

Assembled **Part No. 24511**

Option 2: Full-width shelf

It is ideal for use in applications involving many thin cables with similar or identical diameters. This shelf slides into place and spans the entire width of the chain.

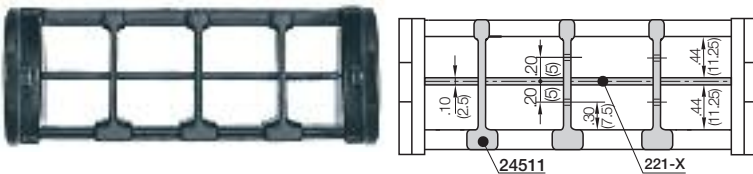

Shelves 220-XX

Shelves can be inserted at 3 different heights in .20" (5mm) increments

Width X	Part No.	Part No.
in. (mm)	Unassembled	Assembled
.98 (25)	220-25	221-25
1.50 (38)	220-38	221-38
2.24 (57)	220-57	221-57
3.03 (77)	220-77	221-77
3.54 (90)	220-90	221-90
4.06 (103)	220-103	221-103
4.92 (125)	220-125	221-125

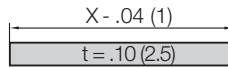

PDF: www.igus.com/e-chain-pdfs
 Specs/CAD/RFQ: www.igus.com/e-chains
 RoHS info: www.igus.com/RoHS



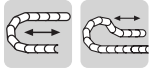

Option 1: pivoting

- For unsupported and gliding applications
- Well suited for tight installation conditions
- Detachable strain relief tiwrap plates
- Can be mounted on the fixed and/or moving end

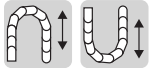
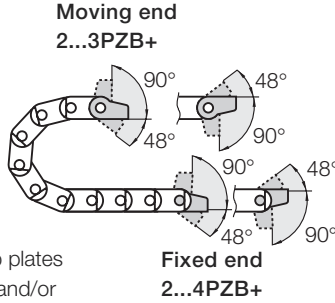

Option 2: locking

- For unsupported and gliding applications
- Extreme speed an/or accelerations
- For height restricted applications
- Can be mounted on the fixed and/or moving end

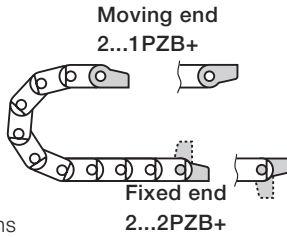

Part Number Structure

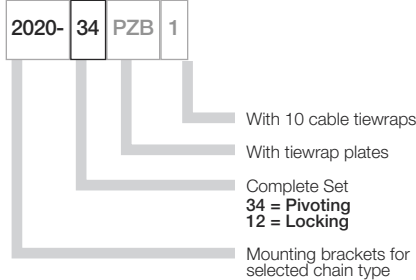

Full set, for both ends:

2020- 34 PZB Full set, each part with pin/bore + tiwrap plate

Single-part order:

2020- 3 PZB Mounting bracket with bore + tiwrap plate

2020- 4 PZB Mounting bracket with pin + tiwrap plate

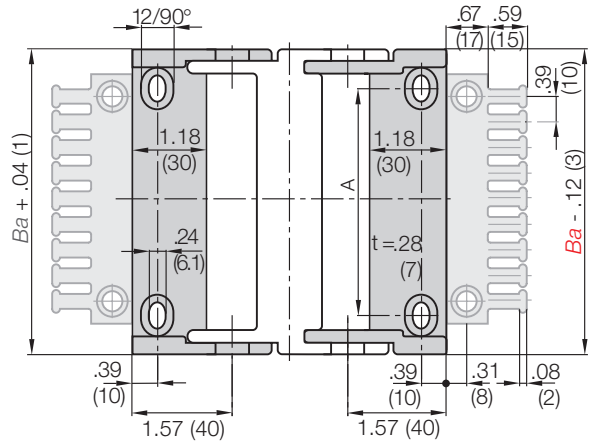

Part No. Full Set (pivoting)

With Tiwrap Plates

Series 2480:

2020-34PZB

Part No. Full Set (locking)

With Tiwrap Plates

+ 10 cable ties

Series 2480:

2020-34PZB1

For Chain Type	Part No. Full set with Tiwrap Plate	Part No. Full Set with Tiwrap Plate + 10 cable ties	Dimension A	
			in.	(mm)
2480-02	2020- <input type="checkbox"/> PZB+	2020- <input type="checkbox"/> PZB1+	.47	(12)
2480-03	2030- <input type="checkbox"/> PZB+	2030- <input type="checkbox"/> PZB1+	.98	(25)
2480-05	2050- <input type="checkbox"/> PZB+	2050- <input type="checkbox"/> PZB1+	1.73	(44)
2480-07	2070- <input type="checkbox"/> PZB+	2070- <input type="checkbox"/> PZB1+	2.52	(64)
2480-09	2090- <input type="checkbox"/> PZB+	2090- <input type="checkbox"/> PZB1+	3.03	(77)
2480-10	2100- <input type="checkbox"/> PZB+	2100- <input type="checkbox"/> PZB1+	3.54	(90)
2480-12	2125- <input type="checkbox"/> PZB+	2125- <input type="checkbox"/> PZB1+	4.41	(112)

34 or 12

For pivoting brackets choose 34

For locking brackets choose 12

Example: 2020- 34 PZB

Energy Chain System® E2 Tubes Series R2480 Mounting Bracket - Steel

energy chain® configurator ▶



R2480

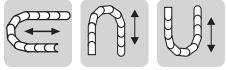

Option 1: Steel

- Pivoting connections
- One part (two-piece) for all chain widths
- Electrically conductive
- Bolted connection outside of chain cross-section possible

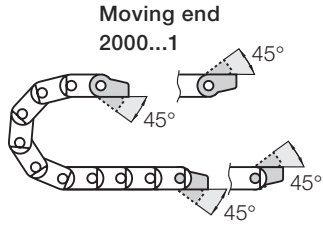

Fixed end
2000...2

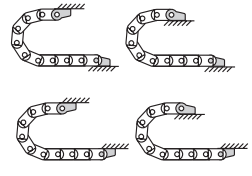

Possible installation configurations -

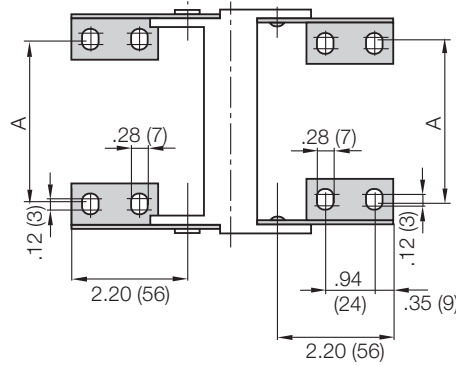
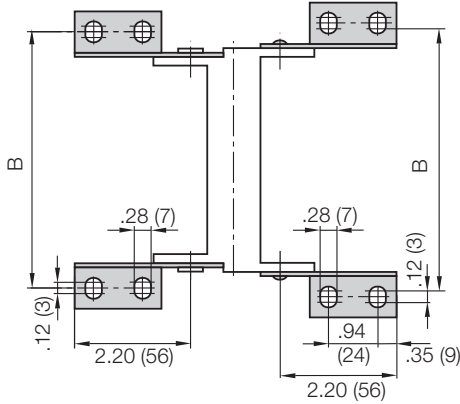

Chain Type	Part No. Full Set	Dimension A		Dimension B	
		in.	(mm)	in.	(mm)
2480-02	2000-12				
2480-03	2000-12	.98	(25)	2.87	(73)
2480-05	2000-12	1.73	(44)	3.62	(92)
2480-07	2000-12	2.52	(64)	4.41	(112)
2480-09	2000-12	2.99	(76)	4.88	(124)
2480-10	2000-12	3.54	(90)	5.43	(138)
2480-12	2000-12	4.41	(112)	6.30	(160)

Part No. Mounting Brackets Full Set
4 parts, 2 with pin, 2 with bore
Series 2480:
2000-12

Part No. Mounting Bracket Moving End
2 parts, 1 left & 1 right
Series 2480:
2000-1

Part No. Mounting Bracket Fixed End
2 parts, 1 left & 1 right
Series 2480:
2000-2

PDF: www.igus.com/e-chain-pdfs
Specs/CAD/RFQ: www.igus.com/e-chains
RoHS info: www.igus.com/RoHS



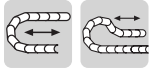

Option 1: pivoting

- For unsupported applications
- Bolted connection outside of chain cross section
- Confined installation conditions
- Attachment points on all sides
- Stackable

Moving end
24801...1

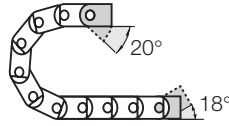

Fixed end
24801...2

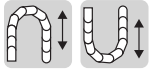
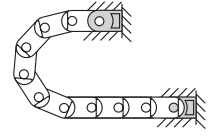

Option 2: locking

- For vertical hanging/standing applications
- Bolted connection outside of chain cross section
- For very high speeds and accelerations
- Attachment points on all sides
- Stackable

Moving end
24811...1

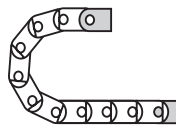

Fixed end
24811...2

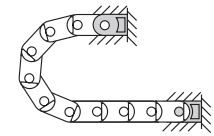

Part Number Structure

24801- 02 12 12

- With tiwrap plates
- Complete Set
- Width
- Mounting brackets for selected chain type
24801 = Pivoting
24811 = Locking

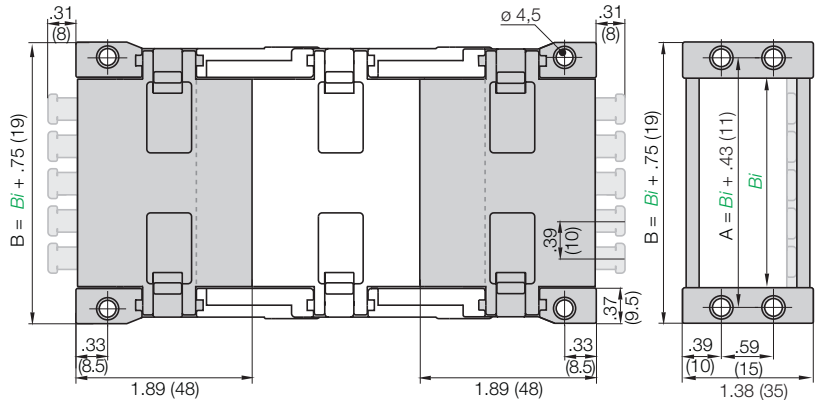

Full set, for both ends:

24801- [12] [ZB] Full set, each part with pin/bore + tiwrap plate

Single-part order:

24801- [1] [ZB] Mounting bracket with bore + tiwrap plate

24801- [2] [ZB] Mounting bracket with pin + tiwrap plate

Part No. Full Set (pivoting)

With Tiwrap Plates

Series 2480:

24801-Width-12ZB

Part No. Full Set (pivoting)

Without Tiwrap Plates

Series 2480:

24801-Width-12

For Chain Type	Part No. Full set with Tiwrap Plate	Part No. Full Set without Tiwrap Plate	Dimension A in. (mm)
2480-02	[] -02-12-ZB	[] -02-12	1.42 (36)
2480-03	[] -03-12-ZB	[] -03-12	1.93 (49)
2480-05	[] -05-12-ZB	[] -05-12	2.68 (68)
2480-07	[] -07-12-ZB	[] -07-12	3.46 (88)
2480-09	[] -09-12-ZB	[] -09-12	3.94 (100)
2480-10	[] -10-12-ZB	[] -10-12	4.49 (114)
2480-12	[] -12-12-ZB	[] -12-12	5.35 (136)

24801 or 24811

For pivoting brackets choose 24801

For locking brackets choose 24811

Example: 24801-02-12-ZB

Tiewrap Plates

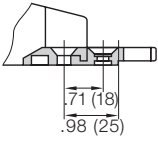

Shown assembled

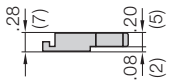

Single tiewrap plate

Option 1:
Tiewrap plates as an individual part

Available as an individual component, can be fixed onto a mounting bracket with the use of a profile rail.

Tiewrap Plates	n Number of Teeth	Dimension C	Dimension B
2020-ZB	3	1.18 (30)	.59 (15)
2030-ZB	4	1.57 (40)	.79 (20)
2040-ZB	5	1.97 (50)	1.18 (30)
2050-ZB	6	2.36 (60)	1.57 (40)
2070-ZB	8	3.15 (80)	2.36 (60)
2090-ZB	9	3.54 (90)	2.76 (70)
2100-ZB	10	3.94 (100)	3.15 (80)
2125-ZB	12	4.72 (120)	3.94 (100)

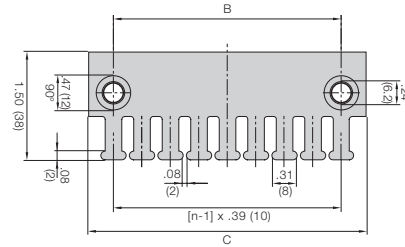

For more information please refer to strain relief section of Chapter 10



Cable tiewraps as individual parts

Cable tiewraps 100 pieces/bag	Width x Length		Maximum Ø		Tensile Strength	
	in.	(mm)	in.	(mm)	lbs	(N)
CFB-001	.19 x 5.91	(4.8 x 150)	1.42	(36)	50	(222)



Strain relief for steel mounting brackets

Clip-on connection is not possible with steel mounting brackets. In this case, the tiewrap plates must be bolted directly into separate bore holes in front of the mounting bracket. Alternatively the tiewrap plates 20XX-ZB can be also used here. **Details chapter 10**

PDF: www.igus.com/e-chain-pdfs
Specs/CAD/RFQ: www.igus.com/e-chains
RoHS info: www.igus.com/RoHS



Guide troughs are used with applications where the upper run of the Energy Chain® glides on the lower run. If using igus® steel guide troughs, the following components are required:

- Full travel length of guide trough
Part Number 92-30
- 1/2 travel length of glide bars
Part Number 92-01
- Installation sets as end connectors
Part Number 92-50-XX

-XX indicates the length of the profile rail on which the guide trough is mounted. The values and part numbers are specified in the table on the left. The standard length of the trough components and glide bars is 6.56 ft (2 m.) The required overall length of the guide trough directly correlates to the length of travel.

Example:
Length of travel 164 ft (50 m)
Center mounted

Required guide troughs:
164 ft (50 m) guide trough
82 ft (25 m) glide bar
= 25 sections of 6.56 ft (2 m) guide trough
Part No. 92-30
= 13 sections of 6.56 ft (2 m) glide bar
Part No. 92-01

Required number of installation sets:
= Number of guide trough components + 1
= 25 + 1 = 26
Part number of the installation sets

Example: 92-50-400 for 15.75" (400 mm) long profile rail.



Width of Crossbar
2480-05-200-0

	B_{Pi}	Installation Part No.
-02	1.81 (46)	92-50-150
-03	2.32 (59)	92-50-175
-05	3.07 (78)	92-50-175
-07	3.86 (98)	92-50-200
-09	4.37 (111)	92-50-250
-10	4.88 (124)	92-50-250
-12	5.75 (146)	92-50-300

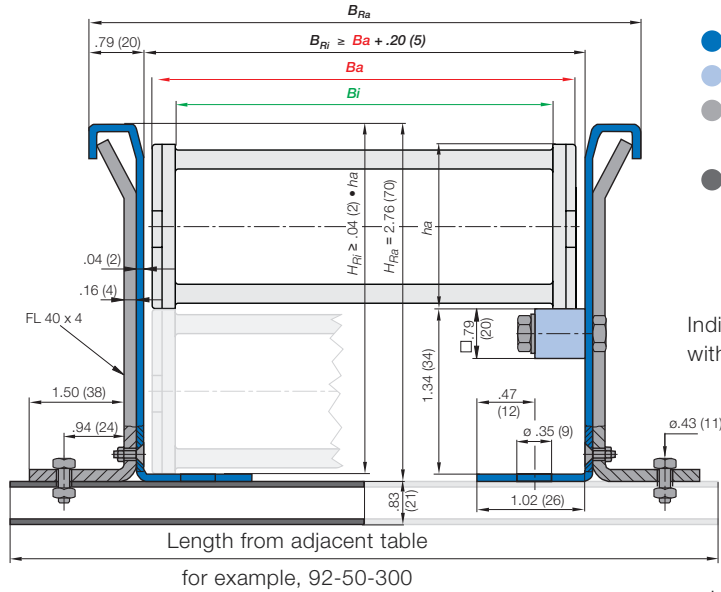

- Guide trough
- Glide bars
- Installation set "Basic"
- Profile rail

Individual attachment without profile rail

* Specialized guide trough available upon request

PDF: www.igus.com/e-chain-pdfs
Specs/CAD/RFQ: www.igus.com/e-chains
RoHS info: www.igus.com/RoHS



Price Index

Series 2680

Special Features / Options

IPA Qualification Certificate
Air Cleanliness Class ISO Class 3
(at v = 6.56 ft/s) upon request



ESD classification:
Electrically conductive
ESD/ATEX version upon request



Flammability Class
VDE 0304 IIC UL94 HB

Assembly Tips

Insert screwdriver into the slot, using a lever action apply pressure to the screwdriver to release

Other Installation Methods

Vertical, hanging ≤ 164 ft (50 m)

Vertical, standing ≤ 9.84 ft (3 m)

Side-mounted, un_supp. ≤ 3.28 ft (1 m)

Rotary requires further calculation

Usage Guidelines



- If hinged, snap-open accessibility along the inner radius is required
- If stable chain of moderate size is required
- If integrated strain relief is required at the connection point
- If loads are moderate
- If chip protection is required
- If easy installation is required



- If the application is very simple
➤ **Series R58 E2 Tubes**
- If maximum stability is required
➤ **Series R770 E4/100**
- If cables over 1.26" (32 mm) are involved
➤ **Series R780 E4/100**

Features & Benefits

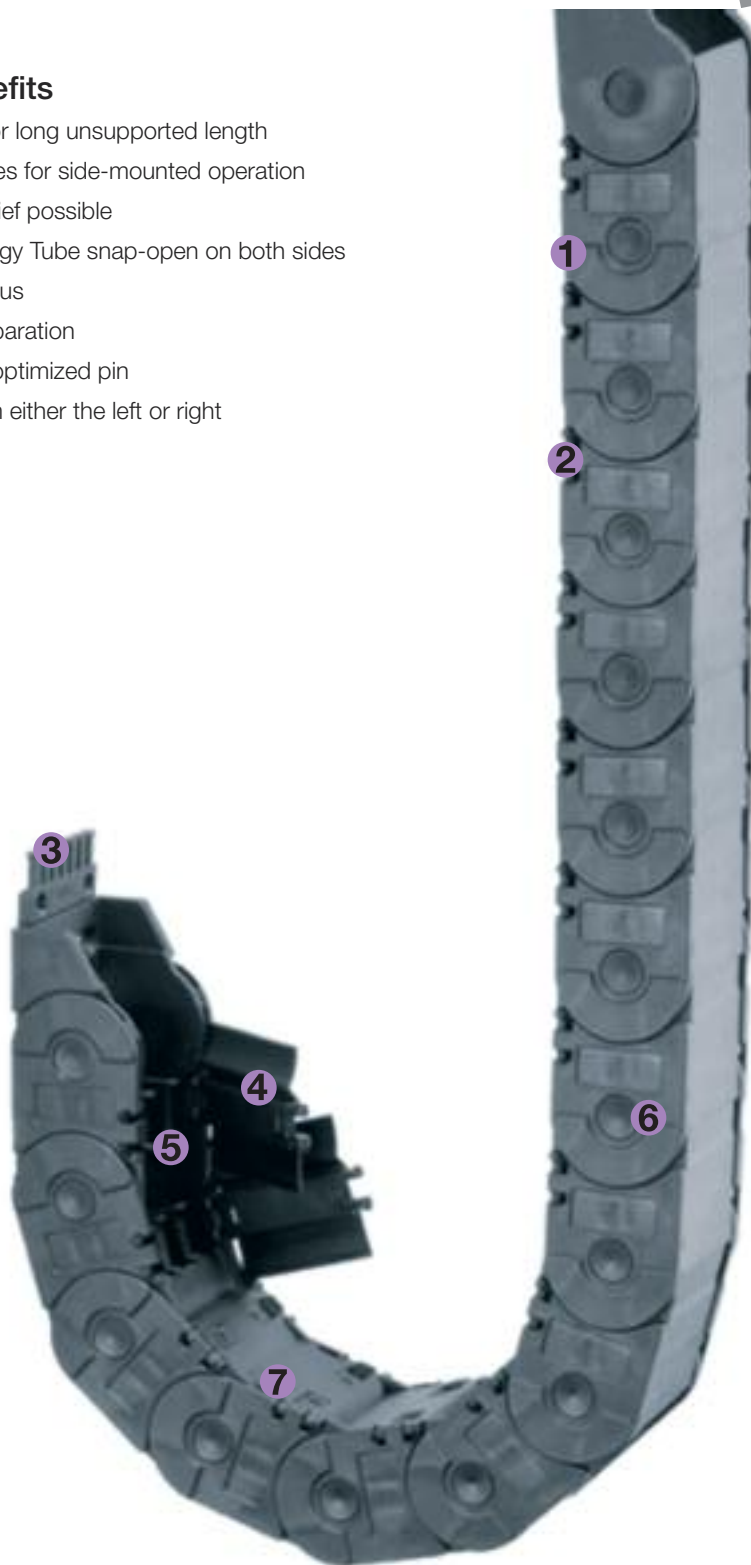
- 1 Double stop dog for long unsupported length
- 2 Lateral glide surfaces for side-mounted operation
- 3 Integrated strain relief possible
- 4 Fully enclosed Energy Tube snap-open on both sides along the inner radius
- 5 Modular interior separation
- 6 Easy assembly by optimized pin
- 7 Rapid opening from either the left or right

Order Example: Complete Energy Chain®

Please indicate chain length or number of links. Example:

energy chain® configurator

9.84 ft (3 m) **2680-10-100-0**



Energy Chain®

With 2 separators **26501** assembled every 2nd link



Interior Separation

1 Set **2610-34 PZB**



Mounting Bracket

Energy Chain System® E2 Tubes Series R2680 Installation Dimensions

energy chain® configurator



R2680

Short travel, unsupported length

- FL_B = unsupported with permitted sag
 - FL_G = unsupported with straight upper run
- Further information Design, Chapter 1

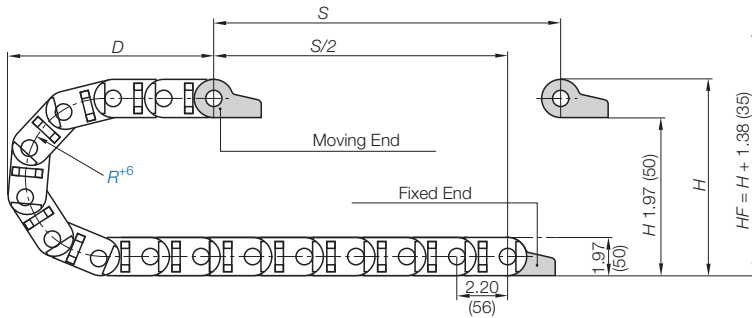
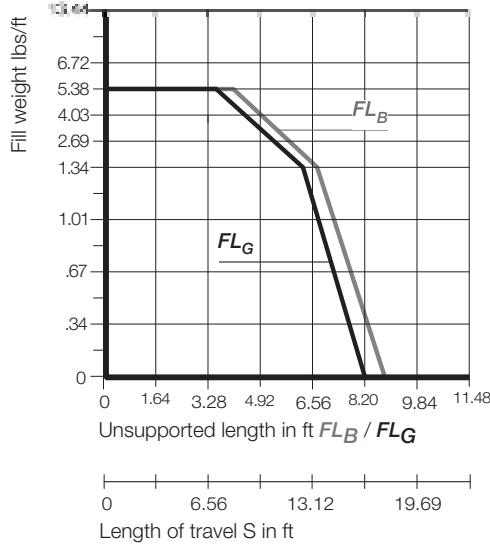
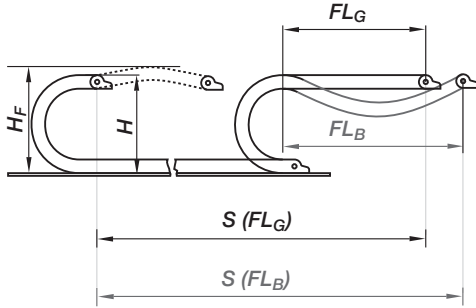

Pitch per link: = 2.20" (56 mm)
Links per foot (m): = 5.49 (18)
For center mount applications:
Chain length = $\frac{S}{2} + K$

The required clearance height: $H_F = H + 1.38$ in. (35 mm) (with 1.34 lbs/ft (2.0 kg/m) fill weight).
Please consult igus® if space is particularly restricted.

R	3.94 (100)	4.92 (125)	5.91 (150)	6.89 (175)	7.87 (200)	9.84 (250)
H	9.84 (250)	11.81 (300)	13.78 (350)	15.75 (400)	17.72 (450)	21.65 (550)
D	8.23 (209)	9.21 (234)	10.20 (259)	11.18 (284)	12.17 (309)	14.13 (359)
K	16.93 (430)	19.88 (505)	23.03 (585)	26.18 (665)	29.33 (745)	35.43 (900)

For long travels with lowered mounting height

Long travel lengths from 32.8 ft. (10 m) to max. 394 ft. (120 m)

For center mount applications:
Chain length: = $\frac{S}{2} + K_2$

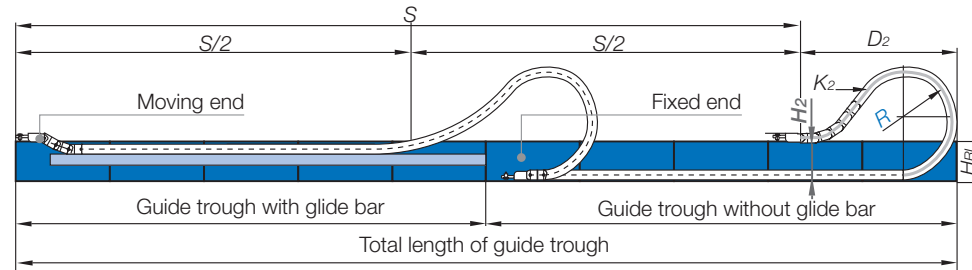

R	3.94 (100)	4.92 (125)	5.91 (150)	6.89 (175)	7.87 (200)	9.84 (250)
H_2	6.54 (166)	6.54 (166)	6.54 (166)	6.54 (166)	6.54 (166)	6.54 (166)
D_2	13.78 (350)	18.70 (475)	19.69 (500)	25.79 (655)	30.31 (770)	37.40 (950)
K_2	24.25 (616)	30.87 (784)	35.28 (896)	44.09 (1120)	50.71 (1288)	63.94 (1624)

Short Travels - Unsupported



Unsupported Energy Chains® feature positive camber over short travels. This must be accounted for when specifying the clearance height. Please refer to **Installation dimensions** for further details.

Legend

- S = Length of travel
 - R = Bending radius
 - H = Nominal clearance height
 - D = Overlength Energy Chain® radius in final position
 - $K = \pi \cdot R + \text{safety buffer}$
 - H_F = Required clearance height
 - H_{R1} = Trough inner height
 - H_2 = *Mounting height
 - D_2 = Overlength - long travels, gliding
 - K_2 = *Add-on
- *If the mounting bracket location is set lower

Long Travels - Gliding



If the unsupported length is exceeded, the Energy Chain®/Tube must glide on itself. This requires a guide trough.

Design, Chapter 1

Technical Data



Details of material properties

Chapter 1

Speed / acceleration FL_G	max. 65.6 ft/s (20 m/s) / max. 656 ft/s ² (200 m/s ²)
Speed / acceleration FL_B	max. 9.84 ft/s (3 m/s) / max. 19.69 ft/s ² (6 m/s ²)
Gliding speed / acceleration (maximum)	max. 32.8 ft/s (10 m/s) / max. 164 ft/s ² (50 m/s ²)
Material - permitted temperature	igumid G / -40°F (-40°C) up to +248°F (+120°C)
Flammability Class, igumid G	VDE 0304 IIC UL94 HB

PDF: www.igus.com/e-chain-pdfs
Specs/CAD/RFQ: www.igus.com/e-chains
RoHS info: www.igus.com/RoHS



Series R2680 - hinged, snap-open along the inner radius

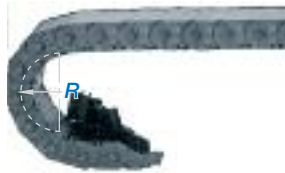
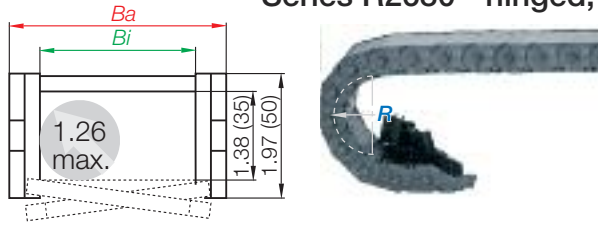

Part Number Structure



Color - Black
Bending radius
Width
Series

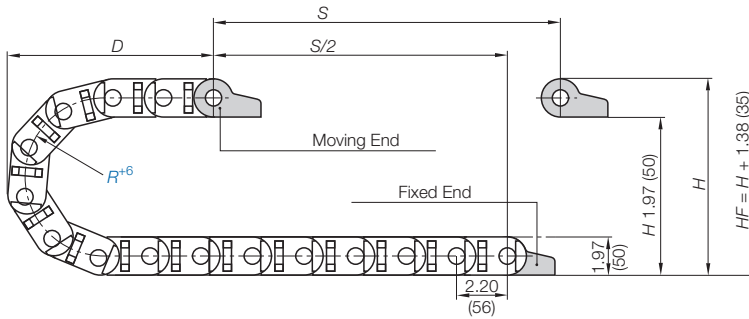

Supplement part number with required radius. Example: 2680-10--0
Pitch: 1.81 in. (46 mm) per link links/ft(m) = 6.71 (22)

Part Number.

Snap-open inner radius	<i>Bi</i> in. (mm)	<i>Ba</i> in. (mm)	Weight lbs/ft (kg/m)
2680-05- <input type="text" value=""/> -0	1.97 (50)	2.60 (66)	≈ 0.89 (1.33)
2680-07- <input type="text" value=""/> -0	2.95 (75)	3.58 (91)	≈ 1.01 (1.51)
2680-10- <input type="text" value=""/> -0	3.94 (100)	4.57 (116)	≈ 1.22 (1.81)
2680-12- <input type="text" value=""/> -0	4.92 (125)	5.55 (141)	≈ 1.34 (1.99)

Choose from the radii below for all of the above sizes

	Radius (mm)					
	100	125	150	175	200	250
R	3.94 (100)	4.92 (125)	5.91 (150)	6.89 (175)	7.87 (200)	9.84 (250)
H	9.84 (250)	11.81 (300)	13.78 (350)	15.75 (400)	17.72 (450)	21.65 (550)
D	8.23 (209)	9.21 (234)	10.20 (259)	11.18 (284)	12.17 (309)	14.13 (359)
K	16.93 (430)	19.88 (505)	23.03 (585)	26.18 (665)	29.33 (745)	35.43 (900)

Example: 2680-10--0

Energy Chain System® E2 Tubes

Series R2680

Interior Separation

energy chain® configurator 



R2680

Option 1: Vertical separators

Vertical separators are used if a vertical subdivision of the Energy Tube interior is required. By standard, vertical separators are assembled every other Energy Tube link.

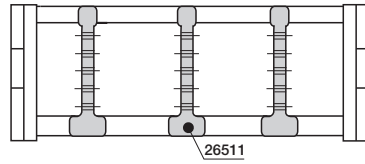

- **Standard separator 26501 for Energy Tubes**
This separator is used for general subdivision of Energy Tubes.

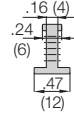

Vertical Separator

Unassembled	Part No. 26501
Assembled	Part No. 26511

Option 2: Full-width shelf

It is ideal for use in applications involving many thin cables with similar or identical diameters. This shelf slides into place and spans the entire width of the chain.

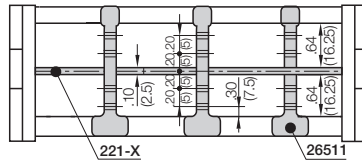

Shelves 220-XX

Shelves can be inserted at 3 different heights in .20" (5mm) increments

Width X in. (mm)	Part No. Unassembled	Part No. Assembled	Width X in. (mm)	Part No. Unassembled	Part No. Assembled
1.97 (50)	220-50	221-50	3.94 (100)	220-100	221-100
2.56 (65)	220-65	221-65	4.92 (125)	220-125	221-125
2.95 (75)	220-75	221-75	5.91 (150)	220-150	221-150
3.54 (90)	220-90	221-90	6.89 (175)	220-175	221-175

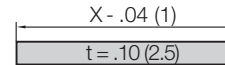

Option 3: shelves

For applications involving many cables with different diameters. This shelf slides into place and spans the entire width of the chain. Use shelf 2200-XX in combination with slotted vertical separator 26510.

- **Open slotted separator 276 for Energy Tubes**
This separator can be retrofitted into an existing interior separation system without removing the shelves, as long as these shelves fit into the 5 middle slots only.

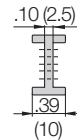
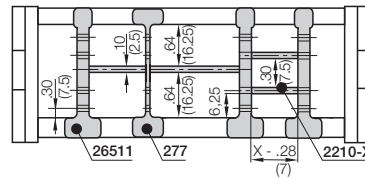

Slotted Separator, Open

Unassembled	Part No. 276
Assembled	Part No. 277

Width X in. (mm)	Part No. Unassembled	Part No. Assembled	Width X in. (mm)	Part No. Unassembled	Part No. Assembled
.71 (18)	2200-18	2210-18	2.28 (58)	2200-58	2210-58
.91 (23)	2200-23	2210-23	2.68 (68)	2200-68	2210-68
1.10 (28)	2200-28	2210-28	2.87 (73)	2200-73	2210-73
1.30 (33)	2200-33	2210-33	3.46 (88)	2200-88	2210-88
1.50 (38)	2200-38	2210-38	3.90 (99)	2200-99	2210-99
1.69 (43)	2200-43	2210-43	4.88 (124)	2200-124	2210-124
1.89 (48)	2200-48	2210-48			

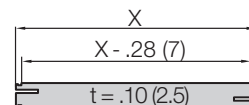

PDF: www.igus.com/e-chain-pdfs
 Specs/CAD/RFQ: www.igus.com/e-chains
 RoHS info: www.igus.com/RoHS



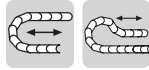

Option 1: pivoting

- For unsupported and gliding applications
- Well suited for tight installation conditions
- Detachable strain relief tiwrap plates
- Can be mounted on the fixed and/or moving end

Moving end
2...3PZB+

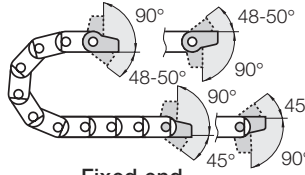

Fixed end
2...4PZB+

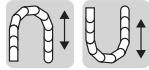
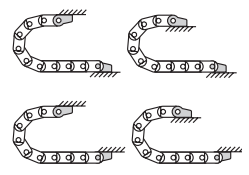

Option 2: locking

- For unsupported and gliding applications
- Extreme speed and/or accelerations
- For height restricted applications
- Can be mounted on the fixed and/or moving end

Moving end
2...1PZB+

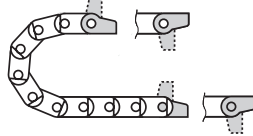

Fixed end
2...2PZB+

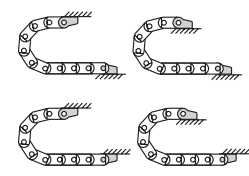

Part Number Structure

2605- 34 PZB K1

- With 10 cable tiwraps
- With tiwrap plates
- Complete Set
34 = Pivoting
12 = Locking
- Mounting brackets for selected chain type

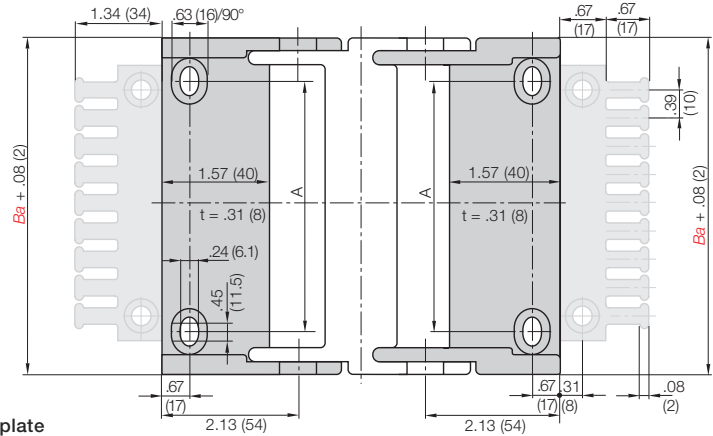

Full set, for both ends:

2605- 34 PZB Full set, each part with pin/bore + tiwrap plate

Single-part order:

2605- 3 PZB Mounting bracket with bore + tiwrap plate

2605- 4 PZB Mounting bracket with pin + tiwrap plate

Part No. Full Set (pivoting)

With Tiwrap Plates

Series 2680:

2605-34PZB

Part No. Full Set (pivoting)

With Tiwrap Plates + 10 cable ties

Series 2680:

2605-34PZBK1

For Chain Type	Part No. Full Set without Tiwrap Plate	Part No. Full Set with Tiwrap Plate	Part No. Full Set with Tiwrap Plate + 10 cable ties	Dimension A	
				in.	(mm)
2680-05	2605- <input type="checkbox"/> PZ	2605- <input type="checkbox"/> PZB	2605- <input type="checkbox"/> PZBK1	1.18	(30)
2680-07	2607- <input type="checkbox"/> PZ	2607- <input type="checkbox"/> PZB	2607- <input type="checkbox"/> PZBK1	2.17	(55)
2680-10	2610- <input type="checkbox"/> PZ	2610- <input type="checkbox"/> PZB	2610- <input type="checkbox"/> PZBK1	3.15	(80)
2680-12	2612- <input type="checkbox"/> PZ	2612- <input type="checkbox"/> PZB	2612- <input type="checkbox"/> PZBK1	4.13	(105)

For pivoting brackets choose 34
For locking brackets choose 12
Example: 2605- 34 PZB

Energy Chain System® E2 Tubes Series R2680 Mounting Bracket - Steel

energy chain® configurator ▶



R2680



Option 1: Steel

- One part (two-piece) for all chain widths
- Electrically conductive
- Bolted connection outside of chain cross-section possible

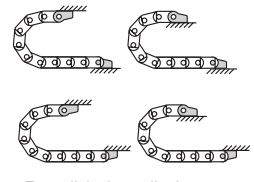
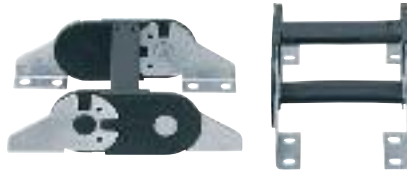
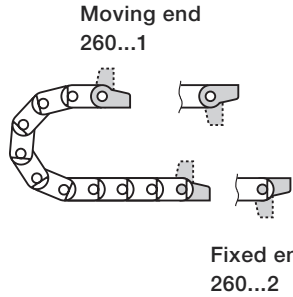

Possible installation configurations -

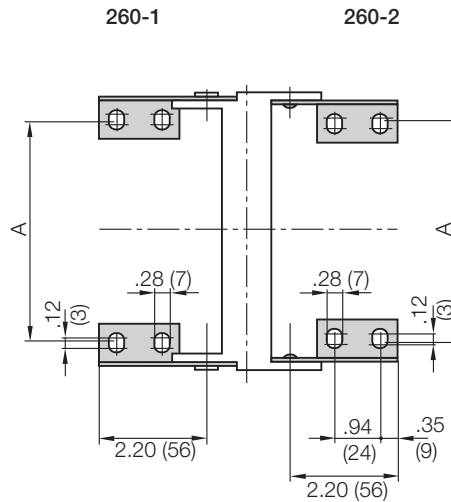
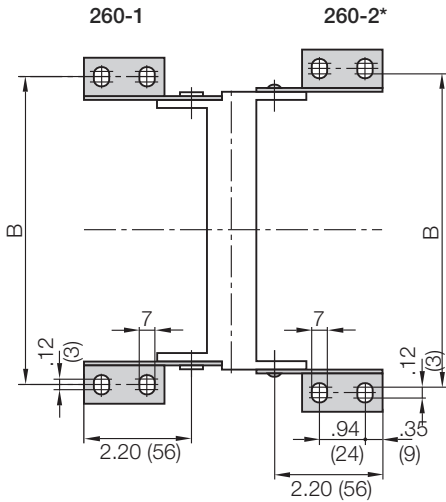

*pivoting with no stop, (360°)

Chain Type	Part No. Full Set	Dimension A		Dimension B	
		in.	(mm)	in.	(mm)
2680-05	260-12	1.46	(37)	3.27	(83)
2680-07	260-12	2.44	(62)	4.25	(108)
2680-10	260-12	3.43	(87)	5.24	(133)
2680-12	260-12	4.41	(112)	6.22	(158)

Part No. Mounting Brackets Full Set
4 parts, 2 with pin, 2 with bore
Series 2680:
260-12

Part No. Mounting Bracket Moving End
2 parts, 1 left & 1 right
Series 2680:
260-1

Part No. Mounting Bracket Fixed End
2 parts, 1 left & 1 right
Series 2680:
260-2

PDF: www.igus.com/e-chain-pdfs
Specs/CAD/RFQ: www.igus.com/e-chains
RoHS info: www.igus.com/RoHS

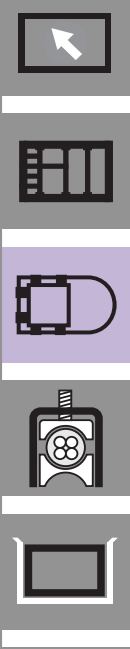

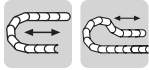

Option 1: pivoting

- For unsupported applications
- Bolted connection outside of chain cross section
- Confined installation conditions
- Attachment points on all sides
- Stackable

Moving end
26800...1

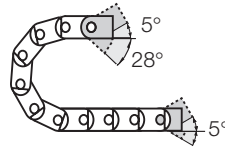

Fixed end
26800...2

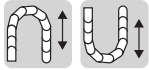
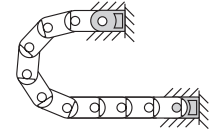

Option 2: locking

- For vertical hanging/standing applications
- Bolted connection outside of chain cross section
- For very high speeds and accelerations
- Attachment points on all sides
- Stackable

Moving end
26810...1

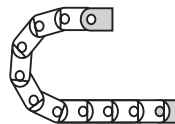

Fixed end
26810...2

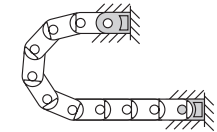

Part Number Structure

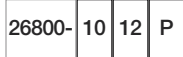

- With profile rail
- Complete Set
- Width
- Mounting brackets for selected chain type
26800 = Pivoting
26810 = Locking

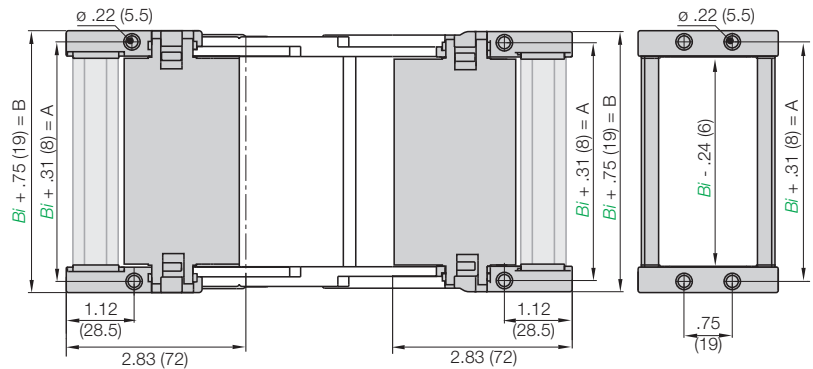

Full set, for both ends:

26800-12 P Full set, each part with pin/bore + proile rail

Single-part order:

26800-1 P Mounting bracket with bore + proile rail

26800-2 P Mounting bracket with pin + proile rail

Part No. Full Set (pivoting)

With Profile Rail

Series 2680:

26800-Width-12P

Part No. Full Set (pivoting)

Without Profile Rail

Series 2680:

26800-Width-12

For Chain Type	Part No. Full set with Profile Rail	Part No. Full Set without Profile Rail	Dimension A in. (mm)	Dimension B in. (mm)
2680-05	-05-12P	-05-12	2.28 (58)	2.72 (69)
2680-07	-07-12P	-07-12	3.27 (83)	3.70 (94)
2680-10	-10-12P	-10-12	4.25 (108)	4.69 (119)
2680-12	-12-12P	-12-12	5.24 (133)	5.67 (144)

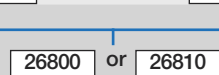

For pivoting brackets choose **26800**

For locking brackets choose **26810**

Example: **24800**-10-12P

Energy Chain System® E2 Tubes

Series R2680

Strain Relief

energy chain® configurator 



R2680

Chainfix clamps for the profile rail



igus® Chainfix strain relief elements are available in either steel or stainless steel. They can be adjusted with a hexagon socket and are available in single, double and triple configurations.

Part No. Single Clamp		Part No. Double Clamp		Part No. Triple Clamp		Cable ø	
Steel	Stainless	Steel	Stainless	Steel	Stainless	in.	(mm)
CFX12-1	CFX12-1E	CFX12-2	CFX12-2E	CFX12-3	-	.24 - .47	(06 - 12)
CFX14-1	CFX14-1E	CFX14-2	CFX14-2E	CFX14-3	-	.47 - .55	(12 - 14)
CFX16-1	CFX16-1E	CFX16-2	CFX16-2E	CFX16-3	-	.55 - .63	(14 - 16)
CFX18-1	CFX18-1E	CFX18-2	CFX18-2E	CFX18-3	-	.63 - .71	(16 - 18)
CFX20-1	CFX20-1E	CFX20-2	CFX20-2E	CFX20-3	-	.71 - .79	(18 - 20)
CFX22-1	CFX22-1E	CFX22-2	CFX22-2E	CFX22-3	-	.79 - .87	(20 - 22)
CFX26-1	CFX26-1E	CFX26-2	CFX26-2E	-	-	.87 - 1.02	(22 - 26)
CFX30-1	CFX30-1E	CFX30-2	CFX30-2E	-	-	1.02 - 1.18	(26 - 30)
CFX34-1	CFX34-1E	CFX34-2	CFX34-2E	-	-	1.18 - 1.34	(30 - 34)
CFX38-1	CFX38-1E	-	-	-	-	1.34 - 1.50	(34 - 38)
CFX42-1	CFX42-1E	-	-	-	-	1.50 - 1.65	(38 - 42)

For more information please refer to strain relief section of Chapter 10

Chainfix Clip



Modular snap-on strain relief device

Chainfix clip is available for cable diameters ranging from .16" (4mm) to .94" (24 mm). It is suitable for assembly on KMA mounting brackets, clip-on strain relief for crossbars as well as profile rails. Quick assembly without the use of tools. **For more information please refer to strain relief section of Chapter 10**

Cable ø	Part No. Clamp	Part No. Bottom
in. (mm)		
.16-.31 (04-08)	CFC-08-M	CFC-08-C
.31-.47 (08-12)	CFC-12-M	CFC-12-C
.47-.63 (12-16)	CFC-16-M	CFC-16-C
.63-.79 (16-20)	CFC-20-M	CFC-20-C
.79-.94 (20-24)	CFC-24-M	CFC-24-C

Tiewrap Plates

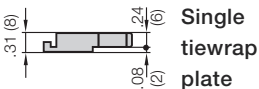
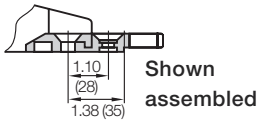

Option 1:

Tiewrap plates as an individual part

Available as an individual component, it can be fixed onto a mounting bracket with the use of a profile rail.

Tiewrap Plate	n Number of Teeth	C Overall Width in. (mm)	B Bore Width in. (mm)	Center Bore
3050-ZB	5	1.97 (50)	1.18 (30)	no
3075-ZB	7	2.95 (75)	2.16 (55)	no
3100-ZB	10	3.94 (100)	3.15 (80)	no
3115-ZB	11	4.53 (115)	3.74 (95)	no
3125-ZB	12	4.92 (125)	4.13 (105)	no
3150-ZB	15	5.91 (150)	5.12 (130)	no
3175-ZB	17	6.89 (175)	6.10 (155)	no
3200-ZB	20	7.87 (200)	7.09 (180)	yes
3225-ZB	22	8.86 (225)	8.07 (205)	yes
3250-ZB	25	9.84 (250)	9.06 (230)	yes

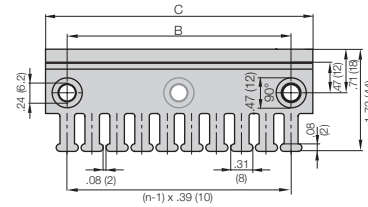

For more information please refer to strain relief section of Chapter 10

Option 2:

Clip-on Tiewrap plates

Available as a clip-on tiewrap plate without the use of bolts They are inserted and removed with a screwdriver used as a lever. Clip-on tiewrap plates are also available as an attachment to the opening crossbars.

Part No.	Number of Teeth	Width of Strain Relief in. (mm)
3050-ZC	5	1.97 (50)
3075-ZC	7	2.95 (75)

For more information please refer to strain relief section of Chapter 10

Strain relief for steel mounting brackets

Clip-on connection is not possible with steel mounting brackets. In this case, the tiewrap plates must be bolted directly into separate bore holes in front of the mounting bracket. Alternatively the tiewrap plates 30XX-Z and ZS can be also used here. **Details chapter 10**

PDF: www.igus.com/e-chain-pdfs
 Specs/CAD/RFQ: www.igus.com/e-chains
 RoHS info: www.igus.com/RoHS



Guide troughs are used with applications where the upper run of the Energy Chain® glides on the lower run. If using igus® steel guide troughs, the following components are required:

- Full travel length of guide trough
Part Number 95-30
- 1/2 travel length of glide bars
Part number 92-01
- Installation sets as end connectors
Part Number 95-50-XX

-XX indicates the length of the profile rail on which the guide trough is mounted. The values and part numbers are specified in the table on the left. The standard length of the trough components and glide bars is 6.56 ft (2 m.) The required overall length of the guide trough directly correlates to the length of travel.

Example:

Length of travel 164 ft (50 m)
Center mounted

Required guide troughs:

164 ft (50 m) guide trough
82 ft (25 m) glide bar
= 25 sections of 6.56 ft (2 m) guide trough

Part No. 95-30

= 13 sections of 6.56 ft (2 m) glide bar

Part No. 92-01

Required number of installation sets:

= Number of guide trough components + 1
= 25 + 1 = 26

Part number of the installation sets

Example: 95-50-400 for 15.75" (400 mm) long profile rail.

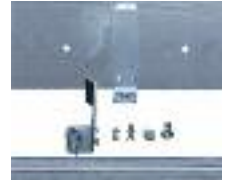

Width of Crossbar
2680-05-200-0

	B_{Ri}	Installation Part No.
-05	2.80 (71)	95-50-200
-07	3.78 (96)	95-50-225
-10	4.76 (121)	95-50-250
-12	5.75 (146)	95-50-250

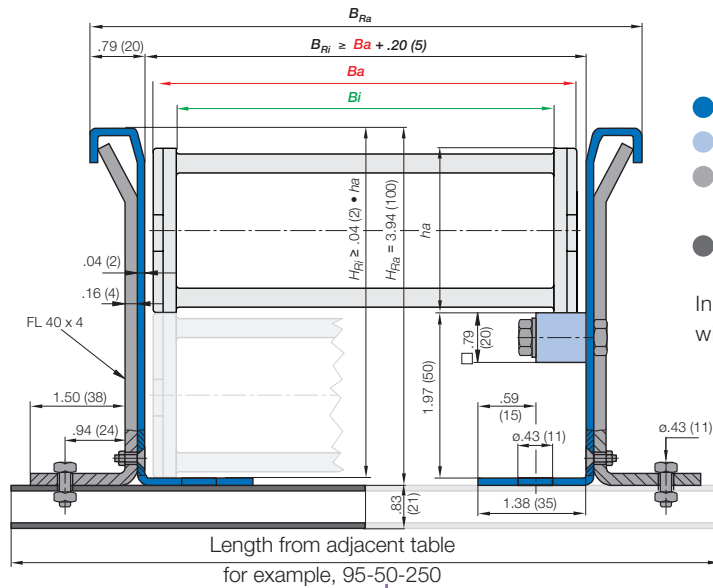

- Guide trough
- Glide bars
- Installation set "Basic"
- Profile rail

Individual attachment without profile rail

Standard length profile rail

* Specialized guide trough available upon request

PDF: www.igus.com/e-chain-pdfs
Specs/CAD/RFQ: www.igus.com/e-chains
RoHS info: www.igus.com/RoHS



Price Index

Series 3480

Special Features / Options

IPA Qualification Certificate
 Air Cleanliness Class ISO Class 3
 (at $v = 6.56$ ft/s) upon request



ESD classification:
 Electrically conductive
 ESD/ATEX version upon request



Flammability Class
 VDE 0304 IIC UL94 HB

Assembly Tips

Insert screwdriver into the slot, using a lever action apply pressure to the screwdriver to release

Other Installation Methods

Vertical, hanging ≤ 262 ft (80 m)

Vertical, standing ≤ 9.84 ft (3 m)

Side-mounted, un supp. ≤ 3.28 ft (1 m)

Rotary requires further calculation

Usage Guidelines

- If hinged, snap-open accessibility along the inner radius is required
- If integrated strain relief is required at the connection point
- If modular interior separation is required
- If chip protection is required
- If easy installation is required
- If long service life is required



- If the application is very simple
 ▶ **Series R68 E2 Tubes**
- If maximum stability is required
 ▶ **Series R780 E4/100**
- If each link requires snap-open accessibility on both sides simultaneously
 ▶ **Series R780 E4/100**

5.87

Features & Benefits

- 1 Double stop dog for long unsupported length
- 2 Lateral glide surfaces for side-mounted operation
- 3 Integrated strain relief possible
- 4 Fully enclosed Energy Tube snap-open on both sides along the inner radius
- 5 Modular interior separation
- 6 Easy assembly by optimized pin
- 7 Rapid opening from either the left or right

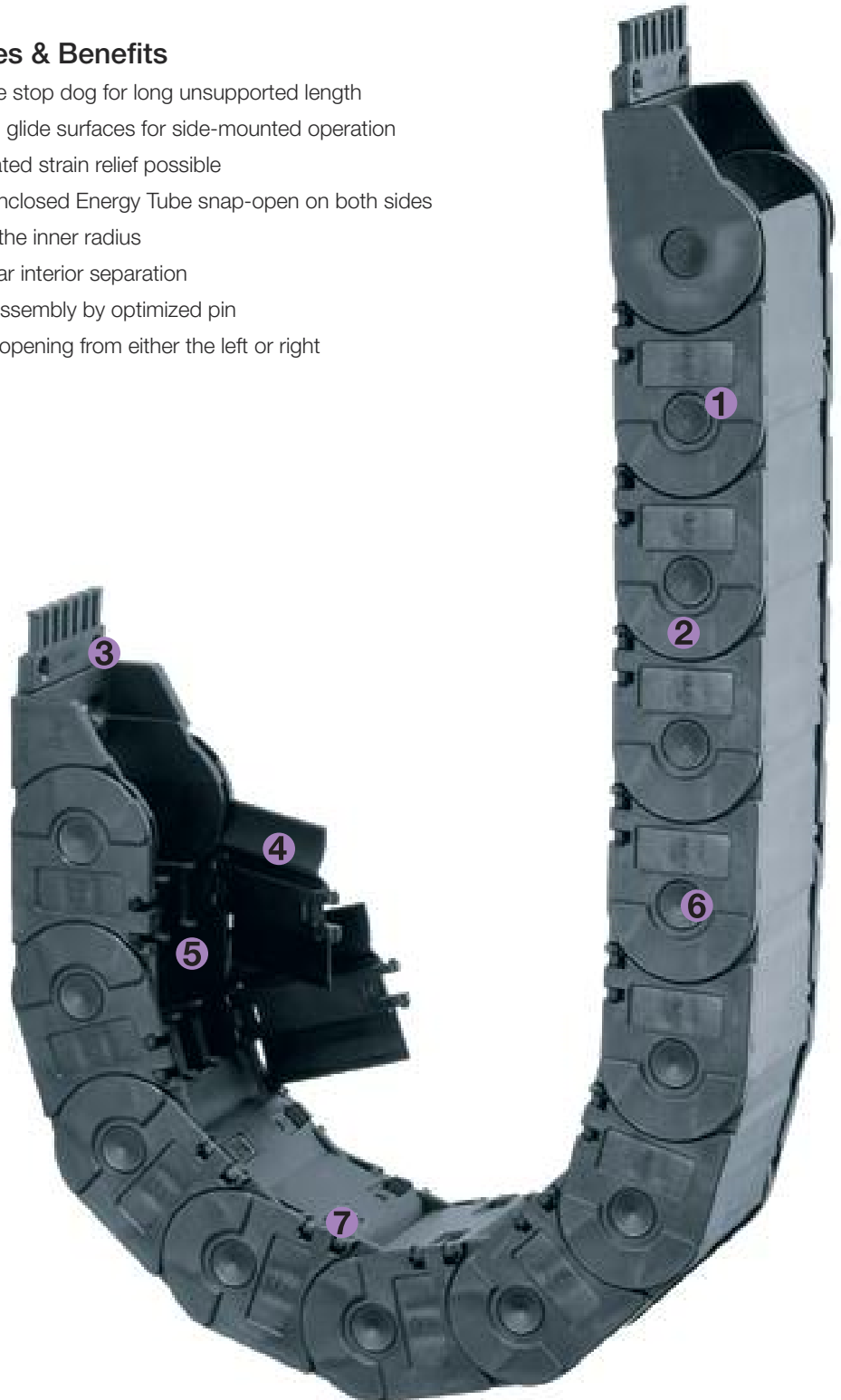
Order Example: Complete Energy Chain®

Please indicate chain length or number of links. Example:

9.84 ft (3 m) **3480-150-100-0**

With 2 separators **34501** assembled every 2nd link

1 Set **3150-34PZB**

energy chain® configurator ▶



Energy Chain®



Interior Separation



Mounting Bracket

Energy Chain System® E2 Tubes Series R3480 Installation Dimensions

energy chain® configurator ▶



R3480

Short travel, unsupported length

- FL_B = unsupported with permitted sag
 - FL_G = unsupported with straight upper run
- Further information ▶ Design, Chapter 1

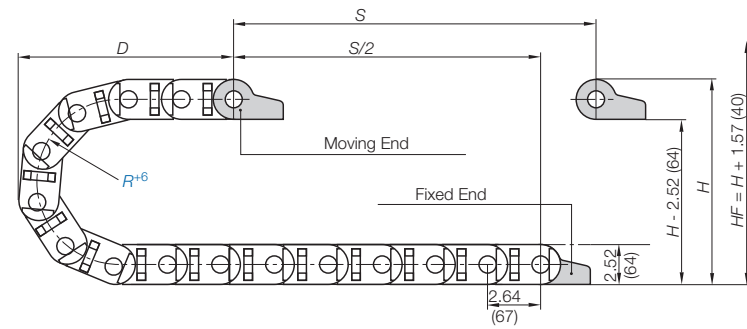
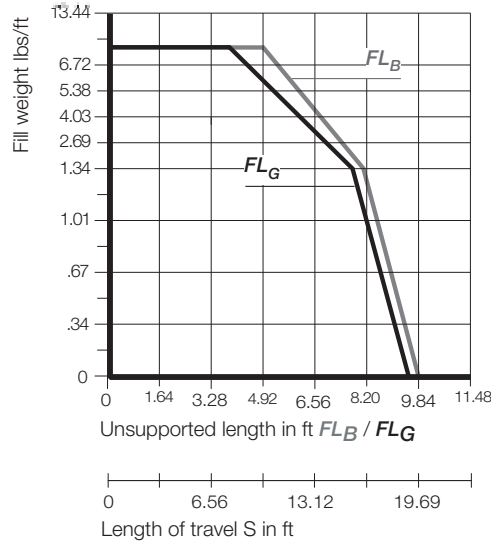
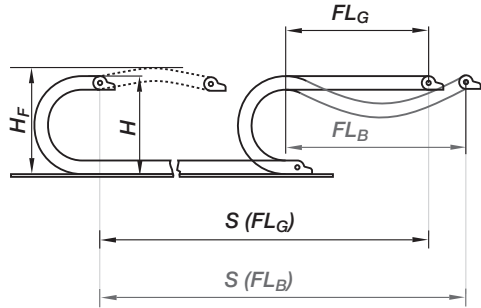

Pitch per link = 2.64" (67 mm)
Links per ft (m) = 4.57 (15)
For center mount applications:
Chain length = $\frac{S}{2} + K$

The required clearance height: $H_f = H + 1.57$ in. (40 mm) (with 1.68 lbs/ft (2.5 kg/m) fill weight.
Please consult igus® if space is particularly restricted.

R	1.50 (075*)	3.94 (100*)	4.92 (125)	5.91 (150)	7.87 (200)	9.84 (250)	11.81 (300)
H	8.43 (214)	10.39 (264)	12.36 (314)	14.33 (364)	18.27 (464)	22.20 (564)	26.14 (664)
D	8.19 (208)	9.17 (233)	10.16 (258)	11.14 (283)	13.11 (333)	15.08 (383)	17.05 (433)
K	14.57 (370)	17.72 (450)	20.87 (530)	24.02 (610)	30.11 (765)	36.22 (920)	42.52 (1080)

*upon request

For long travels with lowered mounting height

Long travel lengths from 32.8 ft. (10 m) to max. 328 ft. (100 m)

Chain length = $\frac{S}{2} + K_2$

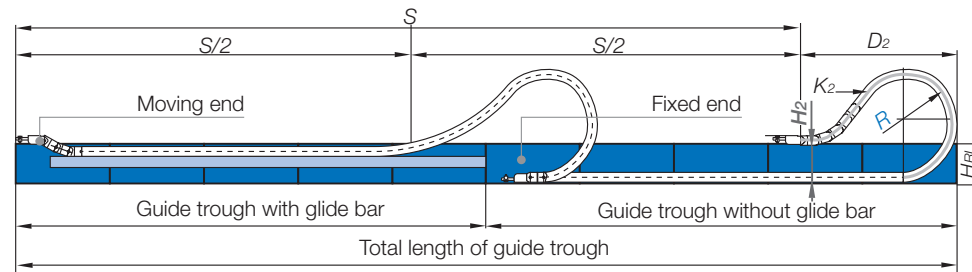

R	1.50 (075*)	3.94 (100*)	4.92 (125)	5.91 (150)	7.87 (200)	9.84 (250)	11.81 (300)
H	-	-	7.32 (186)	7.32 (186)	7.32 (186)	7.32 (186)	7.32 (186)
D	-	-	18.70 (475)	22.44 (570)	30.71 (780)	39.76 (1010)	45.28 (1150)
K	-	-	31.65 (804)	39.57 (1005)	52.76 (1340)	65.94 (1675)	76.50 (1943)

*upon request

Short Travels - Unsupported



Unsupported Energy Chains® feature positive camber over short travels. This must be accounted for when specifying the clearance height. Please refer to **Installation dimensions** for further details.

Legend

- S = Length of travel
- R = Bending radius
- H = Nominal clearance height
- D = Overlength Energy Chain® radius in final position
- $K = \pi \cdot R + \text{safety buffer}$
- H_f = Required clearance height
- H_{R1} = Trough inner height
- H_2 = *Mounting height
- D_2 = Overlength - long travels, gliding
- K_2 = *Add-on
- *If the mounting bracket location is set lower

Long Travels - Gliding



If the unsupported length is exceeded, the Energy Chain®/Tube must glide on itself. This requires a guide trough.

Design, Chapter 1

Technical Data



Details of material properties

▶ Chapter 1

Speed / acceleration FL_G	max. 65.6 ft/s (20 m/s) / max. 656 ft/s ² (200 m/s ²)
Speed / acceleration FL_B	max. 9.84 ft/s (3 m/s) / max. 19.69 ft/s ² (6 m/s ²)
Gliding speed / acceleration (maximum)	max. 32.8 ft/s (10 m/s) / max. 164 ft/s ² (50 m/s ²)
Material - permitted temperature	igumid G / -40°F (-40°C) up to +248°F (+120°C)
Flammability Class, igumid G	VDE 0304 IIC UL94 HB

PDF: www.igus.com/e-chain-pdfs
Specs/CAD/RFQ: www.igus.com/e-chains
RoHS info: www.igus.com/RoHS



Series R3480 - hinged, snap-open along the inner radius

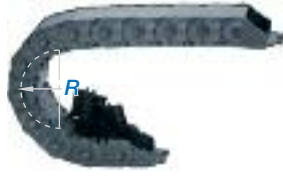
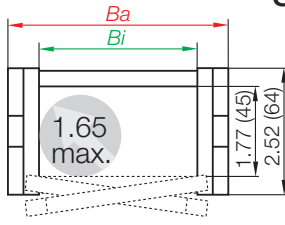

Part Number Structure

3480-075-100-0

- Color - Black
- Bending radius
- Width
- Series

Please note: For using this series for long travels (gliding), please consult with igus® first. For long travels, igus® specifies Energy Chains® that snap open on the outer radius.

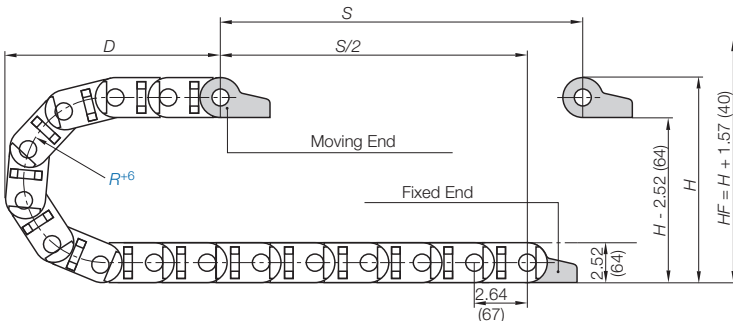

Supplement part number with required radius. Example: 3480-075-**100**-0
Pitch: 2.64 in. (67 mm) per link links/ft(m) = 4.57 (15)

Part Number.

Snap-open inner radius	Bi in. (mm)	Ba in. (mm)	Weight lbs/ft (kg/m)
3480-075- <input type="text"/> -0	2.95 (75)	3.74 (95)	≈ 1.39 (2.07)
3480-100- <input type="text"/> -0	3.94 (100)	4.72 (120)	≈ 1.55 (2.30)
3480-115- <input type="text"/> -0	4.53 (115)	5.31 (135)	≈ 1.65 (2.46)
3480-150- <input type="text"/> -0	5.91 (150)	6.69 (170)	≈ 1.76 (2.62)
3480-175- <input type="text"/> -0	6.89 (175)	7.68 (195)	≈ 1.88 (2.80)

Choose from the radii below for all of the above sizes

Radius (mm) Example: 3480-075-**100**-0

	075*	100	125	150	175	200	250
R	1.50 (075*)	3.94 (100)	4.92 (125)	5.91 (150)	6.89 (175)	7.87 (200)	9.84 (250)
H	8.43 (214)	10.39 (264)	12.36 (314)	14.33 (364)	18.27 (464)	22.20 (564)	26.14 (664)
D	8.19 (208)	9.17 (233)	10.16 (258)	11.14 (283)	13.11 (333)	15.08 (383)	17.05 (433)
K	14.57 (370)	17.72 (450)	20.87 (530)	24.02 (610)	30.11 (765)	36.22 (920)	42.52 (1080)

Energy Chain System® E2 Tubes

Series R3480

Interior Separation

energy chain® configurator 



R3480

Option 1: Vertical separators

Vertical separators are used if a vertical subdivision of the Energy Tube interior is required. By standard, vertical separators are assembled every other Energy Tube link.

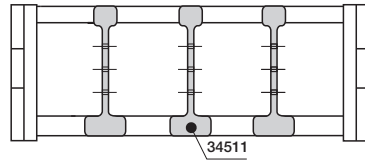

- **Standard separator 26501 for Energy Tubes**
This separator is used for general subdivision of Energy Tubes.

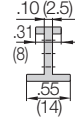

Vertical Separator

Unassembled	Part No. 34501
Assembled	Part No. 34511

Option 2: Full-width shelf

It is ideal for use in applications involving many thin cables with similar or identical diameters. This shelf slides into place and spans the entire width of the chain.

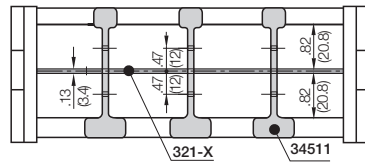

Shelves 220-XX

Shelves can be inserted at 3 different heights in .20" (5mm) increments

Width X in. (mm)	Part No. Unassembled	Part No. Assembled	Width X in. (mm)	Part No. Unassembled	Part No. Assembled
1.97 (50)	320-50	321-50	5.91 (150)	320-150	321-150
2.95 (75)	320-75	321-75	6.89 (175)	320-175	321-175
3.94 (100)	320-100	321-100	7.87 (200)	320-200	321-200
4.53 (115)	320-115	321-115	8.86 (225)	320-225	321-225
4.92 (125)	320-125	321-125	9.84 (250)	320-250	321-250

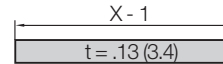

Option 3: shelves

For applications involving many cables with different diameters. This shelf slides into place and spans the entire width of the chain. Use shelf 2200-XX in combination with slotted vertical separator 26510.

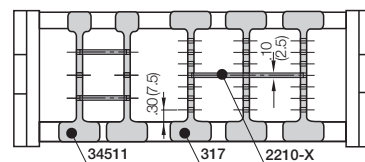

- **Open slotted separator 307 for Energy Tubes**
This separator can be retrofitted into an existing interior separation system without removing the shelves, as long as these shelves fit into the 5 middle slots only.

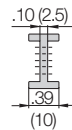

Slotted Separator, Open

Unassembled	Part No. 307
Assembled	Part No. 317

Width X in. (mm)	Part No. Unassembled	Part No. Assembled	Width X in. (mm)	Part No. Unassembled	Part No. Assembled
.71 (18)	2200-18	2210-18	2.28 (58)	2200-58	2210-58
.91 (23)	2200-23	2210-23	2.68 (68)	2200-68	2210-68
1.10 (28)	2200-28	2210-28	2.87 (73)	2200-73	2210-73
1.30 (33)	2200-33	2210-33	3.46 (88)	2200-88	2210-88
1.50 (38)	2200-38	2210-38	3.90 (99)	2200-99	2210-99
1.69 (43)	2200-43	2210-43	4.88 (124)	2200-124	2210-124
1.89 (48)	2200-48	2210-48	5.87 (149)	2200-149	2210-149

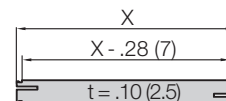

PDF: www.igus.com/e-chain-pdfs
 Specs/CAD/RFQ: www.igus.com/e-chains
 RoHS info: www.igus.com/RoHS



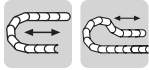

Option 1: pivoting

- For unsupported and gliding applications
- Well suited for tight installation conditions
- Detachable strain relief tiwrap plates
- Can be mounted on the fixed and/or moving end

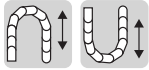
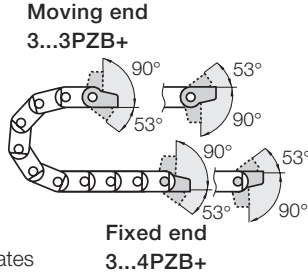

Option 2: locking

- For unsupported and gliding applications
- Extreme speed and/or accelerations
- For height restricted applications
- Can be mounted on the fixed and/or moving end

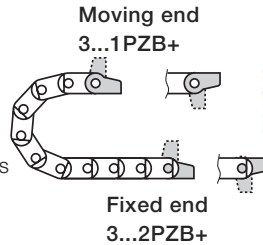

Part Number Structure

3075- 34 PZB K1

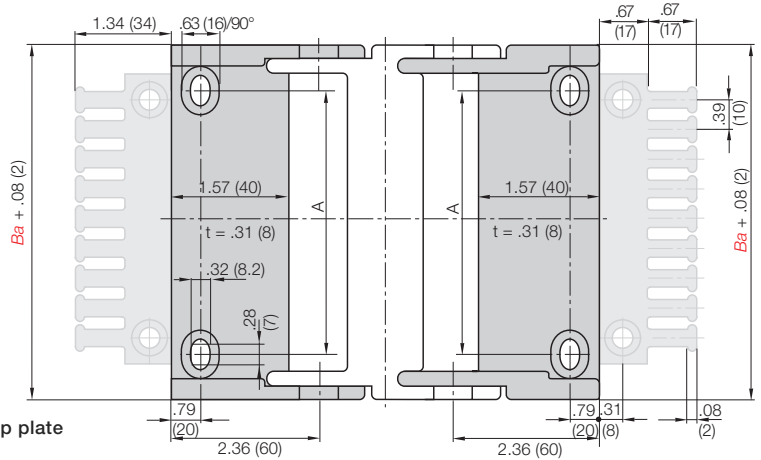
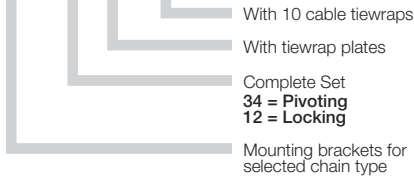

Full set, for both ends:

3075- 34 PZB Full set, each part with pin/bore + tiwrap plate

Single-part order:

3075- 3 PZB Mounting bracket with bore + tiwrap plate

3075- 4 PZB Mounting bracket with pin + tiwrap plate

Part No. Full Set (pivoting)

Without Tiwrap Plates

Series 3480:

3075-34PZ

Part No. Full Set (pivoting)

With Tiwrap Plates

Series 3480:

3075-34PZB

Part No. Full Set (pivoting)

With Tiwrap Plates + 10 cable ties

Series 3480:

3075-34PZBK1

For Chain Type	Part No. Full Set without Tiwrap Plate	Part No. Full Set with Tiwrap Plate	Part No. Full Set with Tiwrap Plate + 10 cable ties	Dimension A	
				in.	(mm)
3480-075	3075- <input type="checkbox"/> PZ	3075- <input type="checkbox"/> PZB	3075- <input type="checkbox"/> PZBK1	2.09	(53)
3480-100	3100- <input type="checkbox"/> PZ	3100- <input type="checkbox"/> PZB	3100- <input type="checkbox"/> PZBK1	3.07	(78)
3480-115	3115- <input type="checkbox"/> PZ	3115- <input type="checkbox"/> PZB	3115- <input type="checkbox"/> PZBK1	3.66	(93)
3480-150	3150- <input type="checkbox"/> PZ	3150- <input type="checkbox"/> PZB	3150- <input type="checkbox"/> PZBK1	5.04	(128)
3480-175	3175- <input type="checkbox"/> PZ	3175- <input type="checkbox"/> PZB	3175- <input type="checkbox"/> PZBK1	6.02	(153)

For pivoting brackets choose **34**
For locking brackets choose **12**
Example: 3075- **34** PZB

Energy Chain System® E2 Tubes Series R3480 Mounting Bracket - Steel

energy chain® configurator ▶



R3480



Option 1: Steel

- One part (two-piece) for all chain widths
- Electrically conductive
- Bolted connection outside of chain cross-section possible

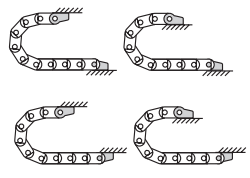
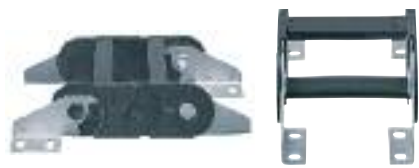
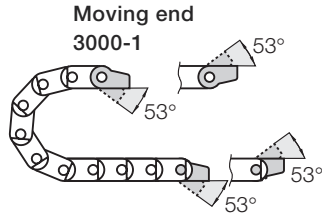

Possible installation configurations -

Fixed end
3000-2

3000-1

3000-2*

3000-1

3000-2

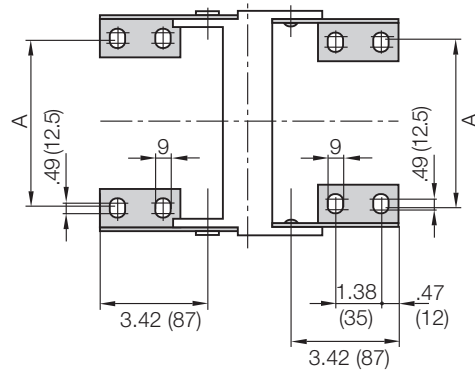
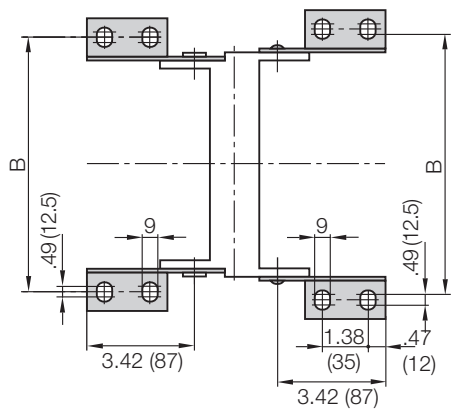

*pivoting with no stop, (360°)

Chain Type	Part No. Full Set	Dimension A		Dimension B	
		in.	(mm)	in.	(mm)
3480-075	3000-12	2.09	(53)	4.37	(111)
3480-100	3000-12	3.07	(78)	5.35	(136)
3480-115	3000-12	3.66	(93)	5.94	(151)
3480-150	3000-12	5.04	(128)	7.32	(186)
3480-175	3000-12	6.02	(153)	8.35	(212)

Part No. Mounting Brackets Full Set

4 parts, 2 with pin, 2 with bore
Series 3480:
3000-12

Part No. Mounting Bracket Moving End

2 parts, 1 left & 1 right
Series 3480:
3000-1

Part No. Mounting Bracket Fixed End

2 parts, 1 left & 1 right
Series 3480:
3000-2

PDF: www.igus.com/e-chain-pdfs
Specs/CAD/RFQ: www.igus.com/e-chains
RoHS info: www.igus.com/RoHS

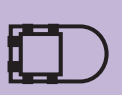

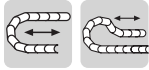

Option 1: pivoting

- For unsupported applications
- Bolted connection outside of chain cross section
- Confined installation conditions
- Attachment points on all sides
- Stackable

Moving end
34800...1

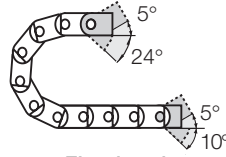

Fixed end
34800...2

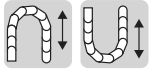
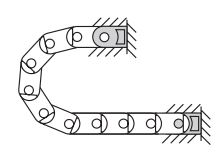

Option 2: locking

- For vertical hanging/standing applications
- Bolted connection outside of chain cross section
- For very high speeds and accelerations
- Attachment points on all sides
- Stackable

Moving end
34810...1

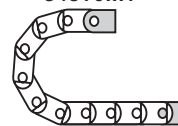

Fixed end
34810...2

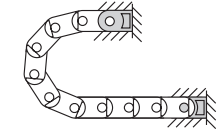

Part Number Structure

34800-075-12 P

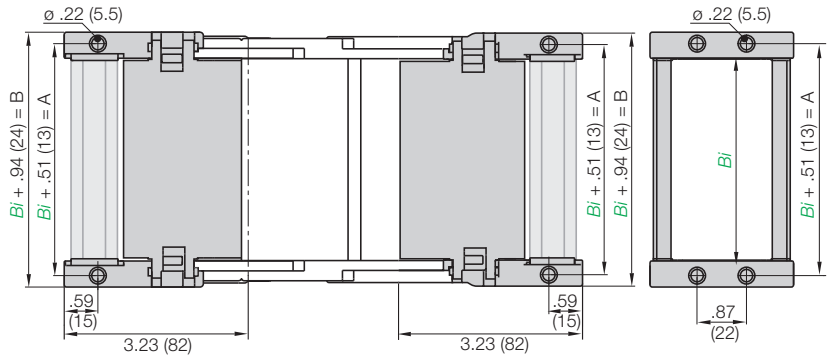
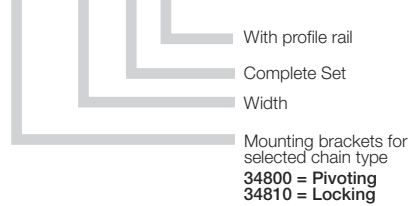

Full set, for both ends:

34800-12 P Full set, each part with pin/bore + proile rail

Single-part order:

34800-1 P Mounting bracket with bore + proile rail

34800-2 P Mounting bracket with pin + proile rail

Part No. Full Set (pivoting)

With Profile Rail

Series 3480:

34800-Width-12P

Part No. Full Set (pivoting)

Without Profile Rail

Series 3480:

34800-Width-12

For Chain Type	Part No. Full set with Profile Rail	Part No. Full Set without Profile Rail	Dimension A in. (mm)	Dimension B in. (mm)
3480-075	<input type="text"/> -075-12P	<input type="text"/> -075-12	3.46 (88)	3.90 (99)
3480-100	<input type="text"/> -100-12P	<input type="text"/> -100-12	4.45 (113)	4.88 (124)
3480-115	<input type="text"/> -115-12P	<input type="text"/> -115-12	5.04 (128)	5.47 (139)
3480-150	<input type="text"/> -150-12P	<input type="text"/> -150-12	6.42 (163)	6.85 (174)
3480-175	<input type="text"/> -175-12P	<input type="text"/> -175-12	7.40 (188)	7.83 (199)

For pivoting brackets choose 34800

For locking brackets choose 34810

Example: 34800-075-12P

34800 or 34810

Energy Chain System® E2 Tubes

Series R3480

Strain Relief

energy chain® configurator 



R3480

Chainfix clamps for the profile rail



igus® Chainfix strain relief elements are available in either steel or stainless steel. They can be adjusted with a hexagon socket and are available in single, double and triple configurations.

Part No. Single Clamp		Part No. Double Clamp		Part No. Triple Clamp		Cable ø	
Steel	Stainless	Steel	Stainless	Steel	Stainless	in.	(mm)
CFX12-1	CFX12-1E	CFX12-2	CFX12-2E	CFX12-3	-	.24 - .47	(06 - 12)
CFX14-1	CFX14-1E	CFX14-2	CFX14-2E	CFX14-3	-	.47 - .55	(12 - 14)
CFX16-1	CFX16-1E	CFX16-2	CFX16-2E	CFX16-3	-	.55 - .63	(14 - 16)
CFX18-1	CFX18-1E	CFX18-2	CFX18-2E	CFX18-3	-	.63 - .71	(16 - 18)
CFX20-1	CFX20-1E	CFX20-2	CFX20-2E	CFX20-3	-	.71 - .79	(18 - 20)
CFX22-1	CFX22-1E	CFX22-2	CFX22-2E	CFX22-3	-	.79 - .87	(20 - 22)
CFX26-1	CFX26-1E	CFX26-2	CFX26-2E	-	-	.87 - 1.02	(22 - 26)
CFX30-1	CFX30-1E	CFX30-2	CFX30-2E	-	-	1.02 - 1.18	(26 - 30)
CFX34-1	CFX34-1E	CFX34-2	CFX34-2E	-	-	1.18 - 1.34	(30 - 34)
CFX38-1	CFX38-1E	-	-	-	-	1.34 - 1.50	(34 - 38)
CFX42-1	CFX42-1E	-	-	-	-	1.50 - 1.65	(38 - 42)

For more information please refer to strain relief section of Chapter 10

Chainfix Clip



Modular snap-on strain relief device

Chainfix clip is available for cable diameters ranging from .16" (4mm) to .94" (24 mm). It is suitable for assembly on KMA mounting brackets, clip-on strain relief for crossbars as well as profile rails. Quick assembly without the use of tools. **For more information please refer to strain relief section of Chapter 10**

Cable ø	Part No. Clamp	Part No. Bottom
in. (mm)		
.16-.31 (04-08)	CFC-08-M	CFC-08-C
.31-.47 (08-12)	CFC-12-M	CFC-12-C
.47-.63 (12-16)	CFC-16-M	CFC-16-C
.63-.79 (16-20)	CFC-20-M	CFC-20-C
.79-.94 (20-24)	CFC-24-M	CFC-24-C

Tiewrap Plates

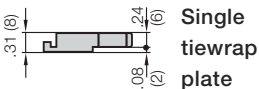
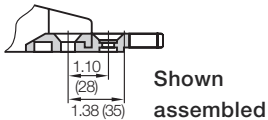

Option 1:

Tiewrap plates as an individual part

Available as an individual component, it can be fixed onto a mounting bracket with the use of a profile rail.

Tiewrap Plate	n Number of Teeth	C Overall Width in. (mm)	B Bore Width in. (mm)	Center Bore
3050-ZB	5	1.97 (50)	1.18 (30)	no
3075-ZB	7	2.95 (75)	2.16 (55)	no
3100-ZB	10	3.94 (100)	3.15 (80)	no
3115-ZB	11	4.53 (115)	3.74 (95)	no
3125-ZB	12	4.92 (125)	4.13 (105)	no
3150-ZB	15	5.91 (150)	5.12 (130)	no
3175-ZB	17	6.89 (175)	6.10 (155)	no
3200-ZB	20	7.87 (200)	7.09 (180)	yes
3225-ZB	22	8.86 (225)	8.07 (205)	yes
3250-ZB	25	9.84 (250)	9.06 (230)	yes

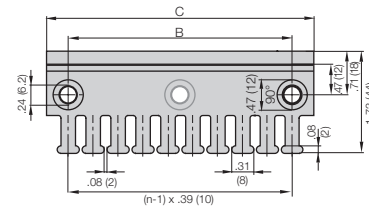

For more information please refer to strain relief section of Chapter 10

Option 2:

Clip-on Tiewrap plates

Available as a clip-on tiewrap plate without the use of bolts They are inserted and removed with a screwdriver used as a lever. Clip-on tiewrap plates are also available as an attachment to the opening crossbars.

Part No.	Number of Teeth	Width of Strain Relief in. (mm)
3050-ZC	5	1.97 (50)
3075-ZC	7	2.95 (75)

For more information please refer to strain relief section of Chapter 10

Strain relief for steel mounting brackets

Clip-on connection is not possible with steel mounting brackets. In this case, the tiewrap plates must be bolted directly into separate bore holes in front of the mounting bracket. Alternatively the tiewrap plates **30XX-Z** and **ZS** can be also used here. **Details chapter 10**

PDF: www.igus.com/e-chain-pdfs
 Specs/CAD/RFQ: www.igus.com/e-chains
 RoHS info: www.igus.com/RoHS





RX Energy





Tubes

RX Tube - Totally new Energy Tube with chip repellent design

A world premiere from igus® - a totally redesigned Energy Tube repels chips, is extremely tight, and can be opened!

- Full chip protection without undercuts, projecting edges and gaps
- Round contour prevents chip accumulation
- Large interior cross section with 2.87" (73 mm) max. inner height
- Covered pin/bore connection and stop dogs
- Reverse bending radius (RBR) becomes a standard option

Typical industries and applications

- Tooling machines
- Woodworking machines
- All kind of industries and machines with chip, dirt and dust



ESD Classification: Electrically conductive
ESD/ATEX version upon request



Flammability Class
VDE 0304 IIC UL94 HB



Energy Tubes with HT-material for hot chips
up to 1562°F (850°C) available upon request





RX Energy Tubes, without undercuts, projecting edges or gaps

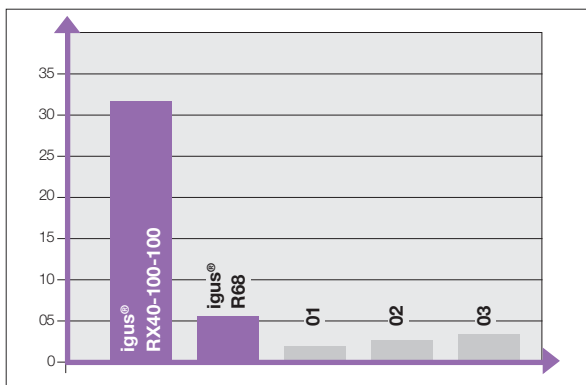

Test 1: Drowning - Various tube styles were submerged under water. For the RX Energy Tube, it takes more than 30 sec. to fill up with water

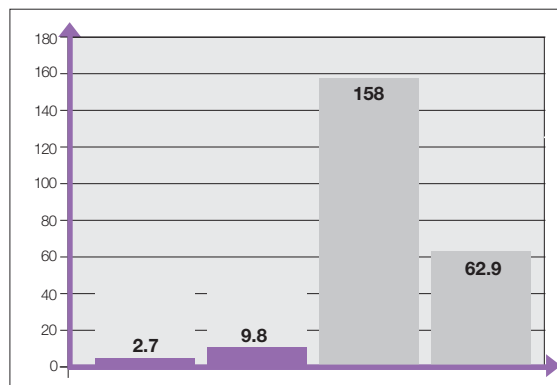

Test 2: Chip intrusion - Various tube styles were charged with a defined quantity of chips. Only 3.7 g of chips were found inside the new RX Energy Tube after 251,900 cycles



Chip-test at the igus® test-lab proven enormous tightness.

Energy Chain System® E2 Medium Series RX40

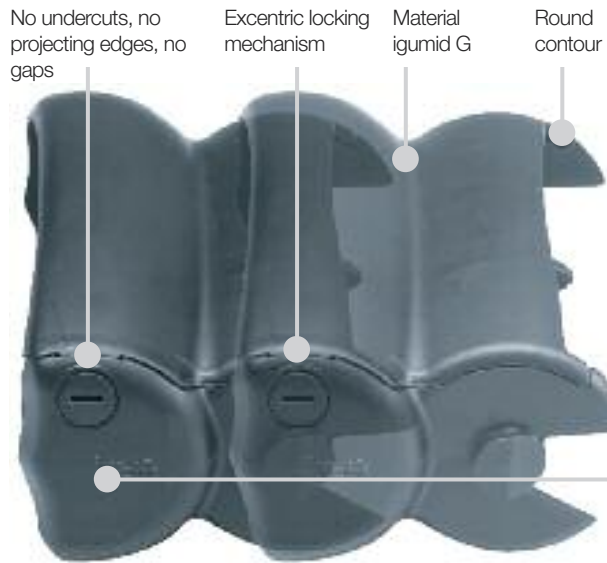

Series RX - new chip protected design, small pitch, lids open

- Full chip protection without undercuts, projecting edges or gaps
- Round contour prevents chip accumulation
- Large interior cross section with 2.05 (52 mm) maximum inner height
- Covered pin/bore connection and stop dogs
- Reverse bending radius (RBR) becomes a standard option
- Perfect fastening with flange mounting brackets
- You can find more technical data about the material, chemical resistance, temperatures ► **Design, Chapter 1**

Fully covered stop dogs and connections

Selection table

Series	Inner height <i>hi</i>		Inner width <i>Bi</i>		Outer width <i>Ba</i>		Outer height <i>ha</i>		Bending radius <i>R</i>	
	in.	(mm)	in.	(mm)	in.	(mm)	in.	(mm)	in.	(mm)
RX32	1.02-1.65	(26-42)	3.15	(80)	3.87	(98.4)	2.20	(56)	3.15-5.91	(80-150)
RX40	1.26/2.05	(32/52)	3.94	(100)	4.84	(123)	2.76	(70)	3.94-11.81	(100-300)
RX48	1.38-2.44	(35-62)	4.72	(120)	5.81	(147.6)	3.31	(84)	4.72-5.91	(120-150)
RX56	1.61-2.87	(41-73)	5.51	(140)	6.78	(172.2)	3.86	(98)	5.51	(140)



Protection from all kinds of chips

Energy Chain System® E2 Medium Series RX40

Energy Tubes - Assembling RX Energy Tube



Easy opening of lids on the outer radius with embedded excentric locking mechanism

Energy Tubes - Interior Separation of the RX Energy Tube



Interior separation with cable-friendly separators and shelves

Price Index



Series RX32

Special Features / Options



ESD classification:
Electrically conductive
ESD/ATEX version upon request



Flammability Class
VDE 0304 IIC UL94 HB

Assembly Tips



Easy opening of lids on the outer radius with embedded excentric locking mechanism

Features & Benefits

- 1 Mounting bracket available with or without strain relief
- 2 Full chip protection without undercuts, projecting edges or gaps
- 3 Large interior cross section
- 4 Round contour prevents chip accumulation
- 5 Covered pin/bore connection and stop dogs
- 6 Lids open from outer radius
- 7 Interior separation available



Usage Guidelines



- If fully protected Energy Tube is desired
- If easy access from the outside is required



- If a particularly low-cost solution is the main factor
 - Series R168 E2 Tubes
- If no chip protection is required
 - Series R4-56 E4-1

Order Example: Complete Energy Chain®

Please indicate chain length or number of links. Example:

3.28 ft (1 m) RX32-080-080-0



Energy Chain®

With 3 separators RX32-1-1/RX32-1-2 assemb. every 2nd link



Interior Separation

1 Set RX321-080-12



Mounting Bracket

Energy Chain System® E2 Tubes Series RX32

energy chain® configurator



RX32

Short travel, unsupported length

- FL_B = unsupported with permitted sag
 - FL_G = unsupported with straight upper run
- Further information Design, Chapter 1

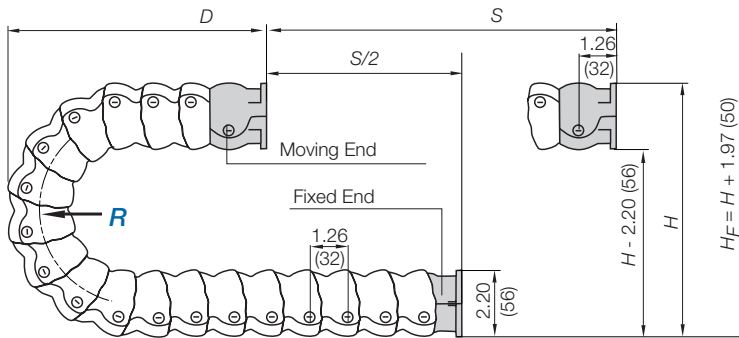
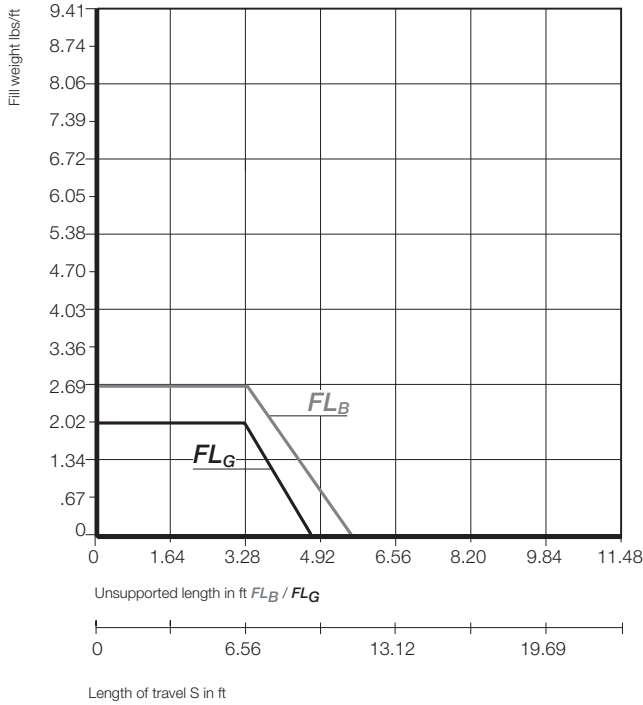
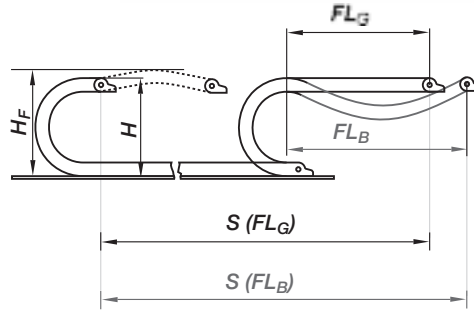

Pitch per link = 1.26" (32 mm)
 Links per ft (m) = 9.52 (32)
 For center mount applications:
 Chain length = $\frac{S}{2} + K$

The required clearance height: $H_F = H + 1.97$ in. (50 mm) (with .34 lbs/ft (0.5 kg/m) fill weight).
 Please consult igus® if space is particularly restricted.

R	3.15 (080)	5.91 (150)
H	8.50 (216)	14.02 (356)
D	5.51 (140)	8.27 (210)
K	12.60 (320)	21.26 (540)

Short Travels - Unsupported



Unsupported Energy Chains® feature positive camber over short travels. This must be accounted for when specifying the clearance height. Please refer to **Installation dimensions** for further details.

Legend

- S = Length of travel
- R = Bending radius
- H = Nominal clearance height
- D = Overlength Energy Chain® radius in final position
- $K = \pi \cdot R + \text{safety buffer}$
- H_F = Required clearance height

1.65

PDF: www.igus.com/echainpdf.asp
 Specs/CAD/RFQ: www.igus.com/echain.asp
 RoHS info: www.igus.com/RoHS.asp



Technical Data

Speed / acceleration FL_G	max. 32.8 ft/s (10 m/s) / max. 328 ft/s ² (100 m/s ²)
Speed / acceleration FL_B	max. 9.84 ft/s (3 m/s) / max. 19.69 ft/s ² (6 m/s ²)
Material - permitted temperature	igumid G / -40°F (-40°C) up to +248°F (+120° C)
Flammability Class, igumid G	VDE 0304 IIC UL94 HB



Details of material properties

Chapter 1

5.102

igus® Energy Chain System®

Telephone 1-800-521-2747
Fax 1-401-438-7270

Internet: <http://www.igus.com>
email: sales@igus.com
QuickSpec: <http://www.igus.com/qs/echain.asp>

Series RX32 - snap-open along the outer radius

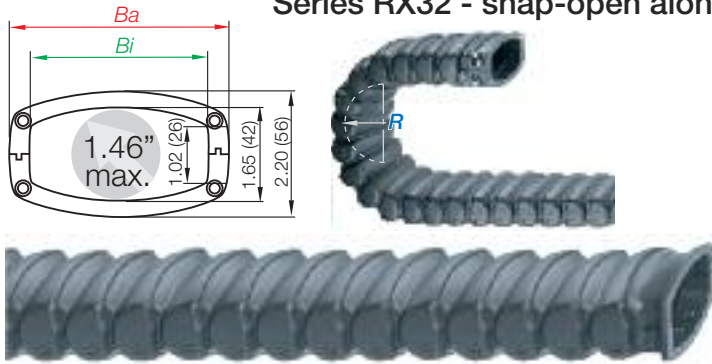

Part Number Structure

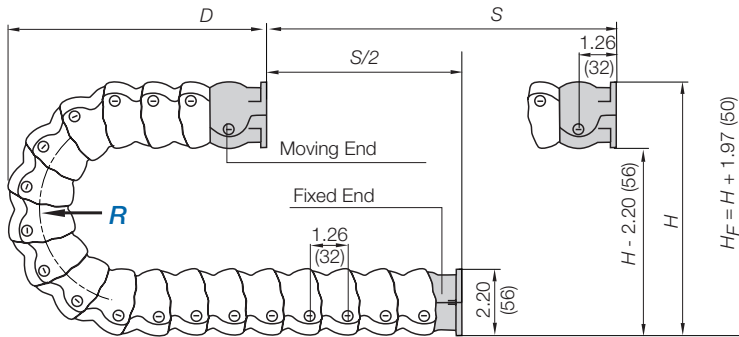
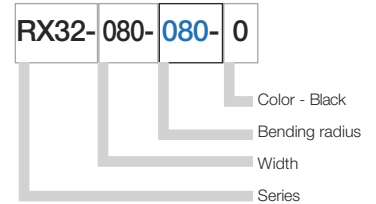

Supplement part number with required radius. Example: RX32-080-080-0
Pitch: 1.26 in. (32 mm) per link links/ft(m) = 9.52 (32)

Part Number	Bi in. (mm)	Ba in. (mm)	Weight lbs/ft (kg/m)
RX32-080- <input type="text"/> -0	3.15 (80)	3.87 (98.4)	≈ 0.83 (1.23)

Choose from the radii below for all of the above sizes
Radius (mm) Example: RX32-080-080-0

	080	150
R	3.15 (80)	5.91 (150)
H	8.50 (216)	14.02 (356)
D	5.51 (140)	8.27 (210)
K	12.60 (320)	21.26 (540)

Separators and shelves

Vertical separators are used if a vertical subdivision of the Energy Tube interior is required. By standard, vertical separators are assembled every other Energy Tube link.

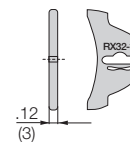
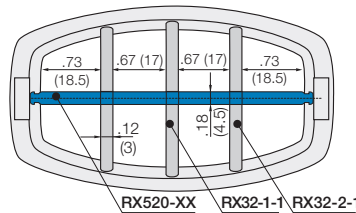

Separator, central
Unassembled Part No. RX32-1
Assembled Part No. RX32-1-1

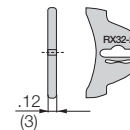

Slotted Separator, lateral
Unassembled Part No. RX32-1
Assembled Part No. RX32-2-1

Shelves RX520-XX

Full width shelves lock into separators on both ends, fixed width possible. Separators can be moved freely over the shelf horizontally.

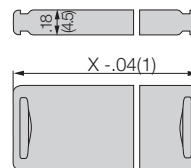

Width X in. (mm)	Part No. Unassembled	Part No. Assembled
1.14 (29)	RX520-29	RX521-29
2.13 (54)	RX520-54	RX521-54
3.11 (79)	RX520-79	RX521-79
4.09 (104)	RX520-104	RX521-104

Energy Chain System® E2 Tubes Series RX32 Mounting Brackets

energy chain® configurator 



RX32



Option: Flange mounting brackets

- Universally mountable with flange attachment capability
- Optional strain relief tiwrap plates
- Easy to open
- Optional M4 insert nuts

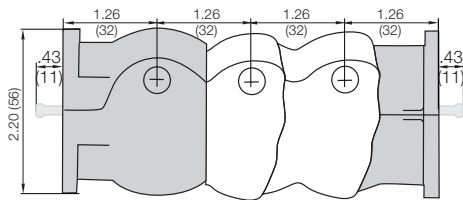
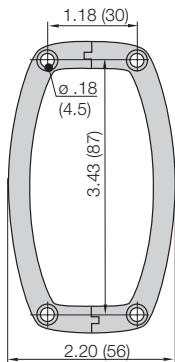
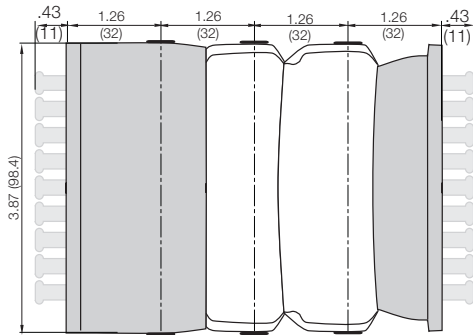
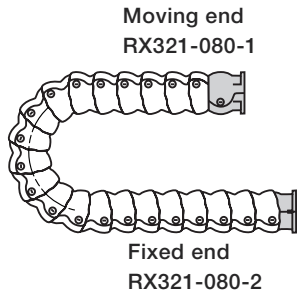

Shown with strain relief



Chain Type	Part No.	Number of Teeth
RX32	RX321-080-12	8

Full set, for both ends:

RX321-080-12

Single-part order:

RX321-080-1 Mounting bracket moving end

RX321-080-2 Mounting bracket fixed end

PDF: www.igus.com/echainpdf.asp
Specs/CAD/RFG: www.igus.com/echain.asp
RoHS info: www.igus.com/RoHS.asp



Price Index

Series RX40

Special Features / Options

ESD classification:
Electrically conductive
ESD/ATEX version upon request



Flammability Class
VDE 0304 IIC UL94 HB



Energy Tubes with HT-material
for hot chips up to 1562°F
(850°C) available upon request

Assembly Tips

Easy opening of lids on the outer radius with embedded excentric locking mechanism

Features & Benefits

- 1 Mounting bracket available with or without strain relief
- 2 Full chip protection without undercuts, projecting edges or gaps
- 3 Large interior cross section
- 4 Round contour prevents chip accumulation
- 5 Covered pin/bore connection and stop dogs
- 6 Lids open from outer radius
- 7 Interior separation available

Usage Guidelines

- If a fully protected Energy Tube is desired
- If easy access from the outside is required



- If a particularly low-cost solution is the main factor
 - **Series R68 E2 Tubes**
- If no chip protection is required
 - **Series 340/350 E2 Medium**

Order Example: Complete Energy Chain®

Please indicate chain length or number of links. Example:

3.28 ft (1 m) **RX-40-100-100-0**



Energy Chain®

With 3 separators **RX40-1-1/RX40-1-2** assemb. every 2nd link



Interior Separation

1 Set **RX401-100-12**



Mounting Bracket

Energy Chain System® E2 Tubes Series RX40 Installation Dimensions

energy chain® configurator ▶



RX40

Short travel, unsupported length

- FL_B = unsupported with permitted sag
 - FL_G = unsupported with straight upper run
- Further information ▶ Design, Chapter 1

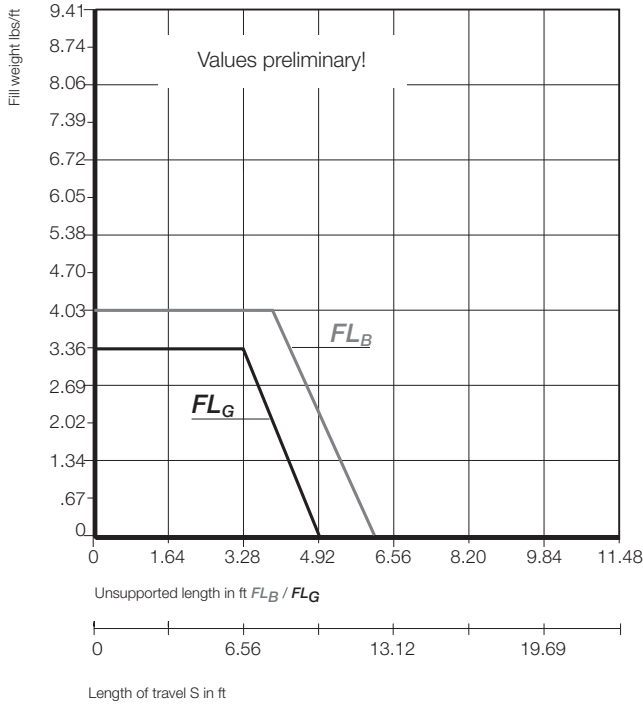
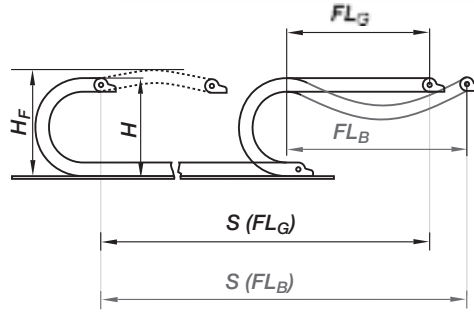

Short Travels - Unsupported



Unsupported Energy Chains® feature positive camber over short travels. This must be accounted for when specifying the clearance height. Please refer to **Installation dimensions** for further details.

Legend

- S = Length of travel
- R = Bending radius
- H = Nominal clearance height
- D = Overlength Energy Chain® radius in final position
- $K = \pi \cdot R + \text{safety buffer}$
- H_F = Required clearance height

2.05

PDF: www.igus.com/e-chain-pdfs
Specs/CAD/RFQ: www.igus.com/e-chains
RoHS info: www.igus.com/RoHS

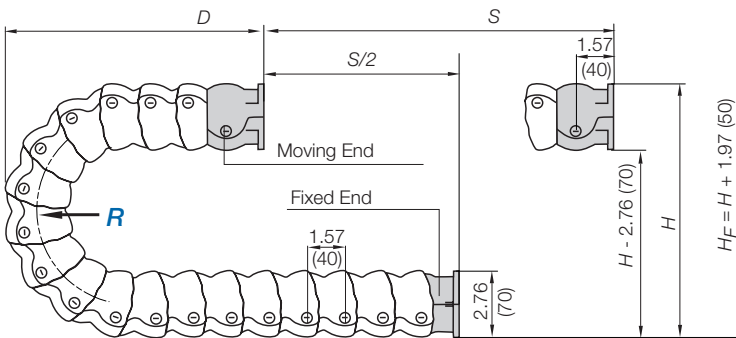

Pitch per link = 1.57" (40 mm)
Links per ft (m) = 7.62 (25)
For center mount applications:
Chain length = $\frac{S}{2} + K$

The required clearance height: $H_F = H + 1.97$ in. (50 mm) (with 1.68 lbs/ft (2.5 kg/m) fill weight. Please consult igus® if space is particularly restricted.

R	3.94 (100)	4.92 (125)	5.91 (150)	6.89 (175)	7.87 (200)	8.86 (225)	9.84 (250)	10.83 (275)	11.81 (300)
H	10.63 (270)	12.59 (320)	14.57 (370)	16.54 (420)	18.50 (470)	20.47 (520)	22.44 (570)	24.41 (620)	26.38 (670)
D	6.89 (175)	7.87 (200)	8.86 (225)	9.84 (250)	10.83 (275)	11.81 (300)	12.80 (325)	13.78 (350)	14.76 (375)
K	15.55 (395)	18.70 (475)	21.85 (555)	24.80 (630)	27.95(710)	31.10 (790)	34.25 (870)	37.20 (945)	40.35(1025)

Technical Data

Speed / acceleration FL_G	max. 32.8 ft/s (10 m/s) / max. 328 ft/s ² (100 m/s ²)
Speed / acceleration FL_B	max. 9.84 ft/s (3 m/s) / max. 19.69 ft/s ² (6 m/s ²)
Material - permitted temperature	igumid G / -40°F (-40°C) up to +248°F (+120° C)
Flammability Class, igumid G	VDE 0304 IIC UL94 HB



Details of material properties

▶ Chapter 1

5.106

Series RX40 - snap-open along the outer radius

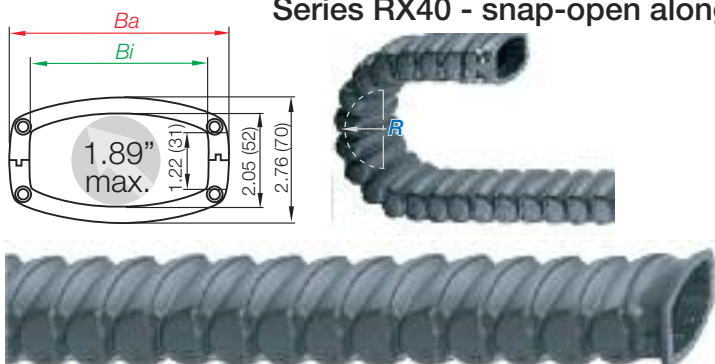

Part Number Structure

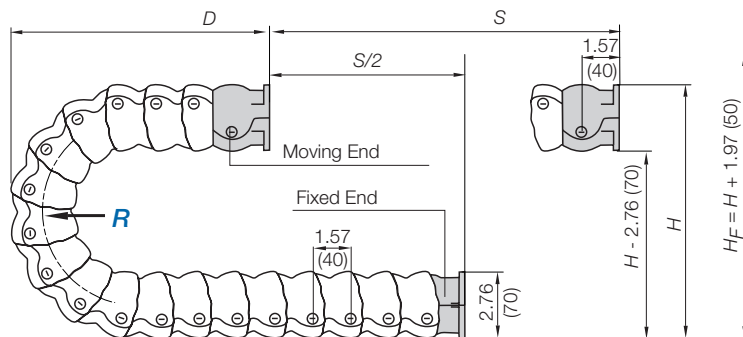
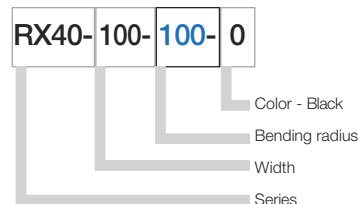

Supplement part number with required radius. Example: RX40-100-**100**-0
Pitch: 1.57 in. (40 mm) per link links/ft(m) = 7.62 (25)

Part Number	Bi in. (mm)	Ba in. (mm)	Weight lbs/ft (kg/m)
RX40-100- <input type="text"/> -0	3.94 (100)	4.84 (123)	≈ 1.27 (1.89)

Choose from the radii below for all of the above sizes
Radius (mm) Example: RX40-100-**100**-0

	100	150
R	3.94 (100)	5.91 (150)
H	10.63 (270)	14.57 (370)
D	6.89 (175)	8.86 (225)
K	15.55 (395)	21.85 (555)

Separators and shelves

Vertical separators are used if a vertical subdivision of the Energy Tube interior is required. By standard, vertical separators are assembled every other Energy Tube link.

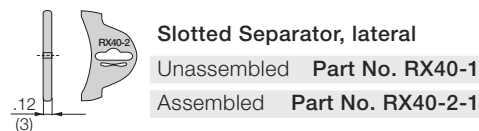
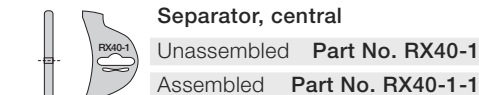
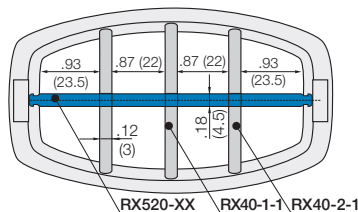

Shelves RX520-XX

Full width shelves lock into separators on both ends, fixed width possible. Separators can be moved freely over the shelf horizontally.

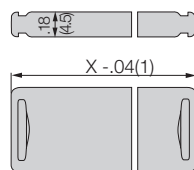

Width X in. (mm)	Part No. Unassembled	Part No. Assembled
1.14 (29)	RX520-24	RX521-24
2.13 (54)	RX520-44	RX521-44
3.11 (79)	RX520-64	RX521-64
4.09 (104)	RX520-84	RX521-84

Energy Chain System® E2 Tubes Series RX40 Mounting Brackets

energy chain® configurator ▶



RX40



Option: Flange mounting brackets

- Universally mountable with flange attachment capability
- Optional strain relief tiwrap plates
- Easy to open
- Optional M4 insert nuts

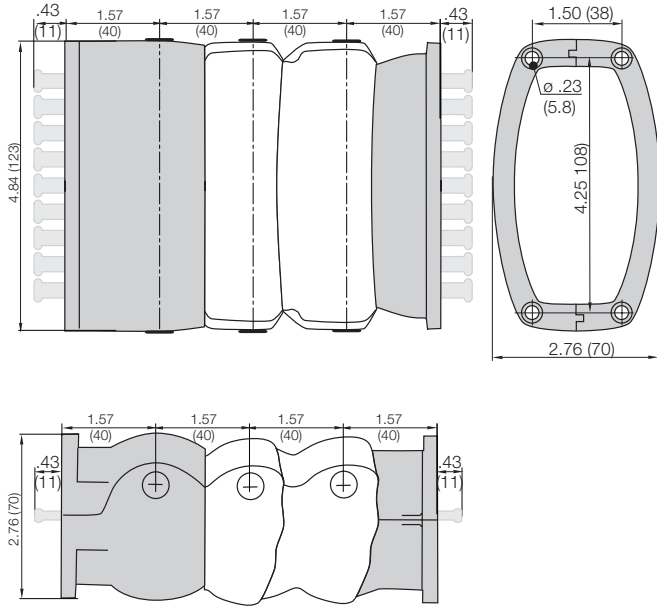
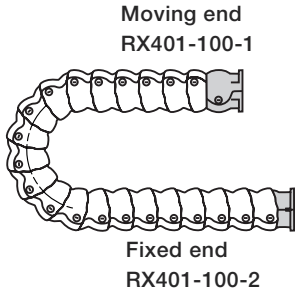

Chain Type	Part No.	Number of Teeth
RX40	RX401-100-12	10

Full set, for both ends:
RX401-100-12
 Single-part order:
RX401-100-1 Mounting bracket moving end
RX401-100-2 Mounting bracket fixed end

PDF: www.igus.com/e-chain-pdfs
 Specs/CAD/RFG: www.igus.com/e-chains
 RoHS info: www.igus.com/RoHS



Price Index

Series RX48

Special Features / Options

ESD classification:
Electrically conductive
ESD/ATEX version upon request



Flammability Class
VDE 0304 IIC UL94 HB

Assembly Tips

Easy opening of lids on the outer radius with embedded excentric locking mechanism

Features & Benefits

- 1 Mounting bracket available with or without strain relief
- 2 Full chip protection without undercuts, projecting edges or gaps
- 3 Large interior cross section
- 4 Round contour prevents chip accumulation
- 5 Covered pin/bore connection and stop dogs
- 6 Lids open from outer radius
- 7 Interior separation available

Usage Guidelines

- If a fully protected Energy Tube is desired
- If easy access from the outside is required



- For chip protection in gliding applications
➤ Series R18840 E4 Light

Order Example: Complete Energy Chain®

Please indicate chain length or number of links. Example:

9.84 ft (3 m) RX48-120-120-0



Energy Chain®

With 3 separators RX48-1-1/RX48-1-2 assemb. every 2nd link



Interior Separation

1 Set RX48-120-12



Mounting Bracket

Energy Chain System® E2 Tubes Series RX48 Installation Dimensions

energy chain® configurator ▶

igus®

RX48

Short travel, unsupported length

- FL_B = unsupported with permitted sag
 - FL_G = unsupported with straight upper run
- Further information ▶ Design, Chapter 1

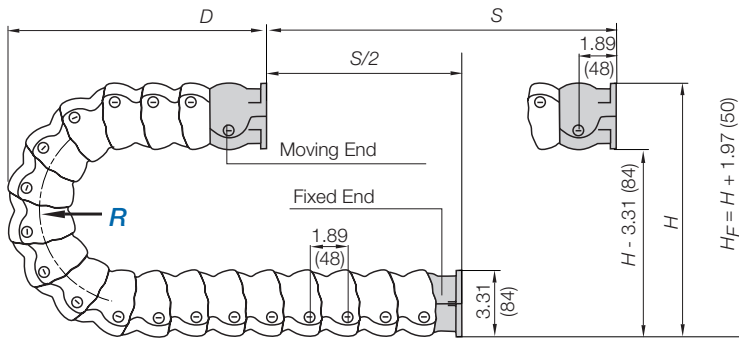
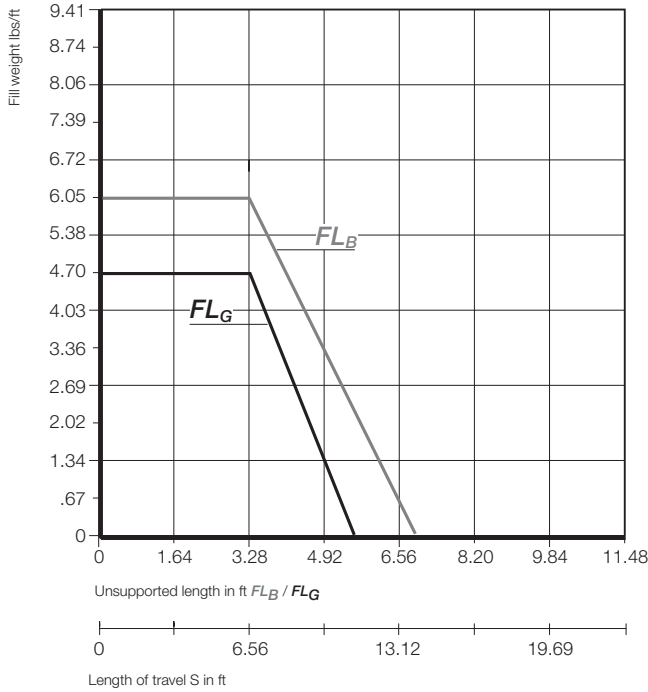
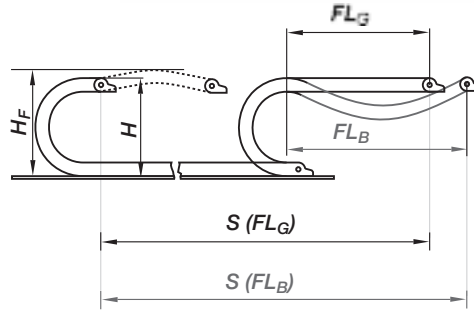

Pitch per link = 1.89" (48 mm)
Links per ft (m) = 6.35 (21)
For center mount applications:
Chain length = $\frac{S}{2} + K$

The required clearance height: $H_F = H + 1.97$ in. (50 mm) (with .34 lbs/ft (0.5 kg/m) fill weight).
Please consult igus® if space is particularly restricted.

R	4.72 (120)	5.91 (150)
H	12.76 (324)	15.12 (384)
D	8.27 (210)	9.45 (240)
K	18.70 (475)	22.44 (570)

Short Travels - Unsupported



Unsupported Energy Chains® feature positive camber over short travels. This must be accounted for when specifying the clearance height. Please refer to **Installation dimensions** for further details.

Legend

- S = Length of travel
- R = Bending radius
- H = Nominal clearance height
- D = Overlength Energy Chain® radius in final position
- $K = \pi \cdot R + \text{safety buffer}$
- H_F = Required clearance height

2.44

PDF: www.igus.com/echainpdf.asp
Specs/CAD/RFQ: www.igus.com/echain.asp
RoHS info: www.igus.com/RoHS.asp



Technical Data

Speed / acceleration FL_G	max. 32.8 ft/s (10 m/s) / max. 328 ft/s ² (100 m/s ²)
Speed / acceleration FL_B	max. 9.84 ft/s (3 m/s) / max. 19.69 ft/s ² (6 m/s ²)
Material - permitted temperature	igumid G / -40°F (-40°C) up to +248°F (+120°C)
Flammability Class, igumid G	VDE 0304 IIC UL94 HB



Details of material properties

▶ Chapter 1

5.110

igus® Energy Chain System®

Telephone 1-800-521-2747
Fax 1-401-438-7270

Internet: <http://www.igus.com>
email: sales@igus.com
QuickSpec: <http://www.igus.com/qs/echain.asp>
5.111

Series RX48 - snap-open along the outer radius

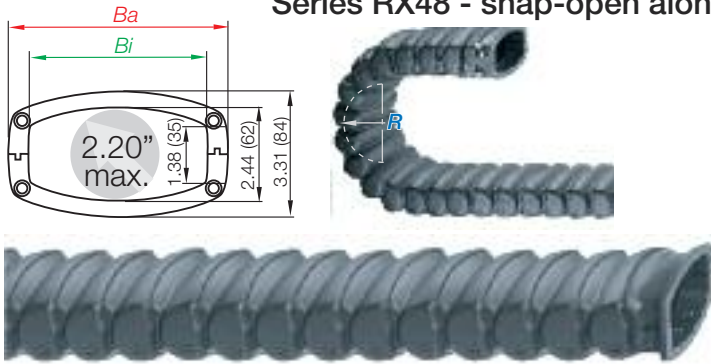

Part Number Structure

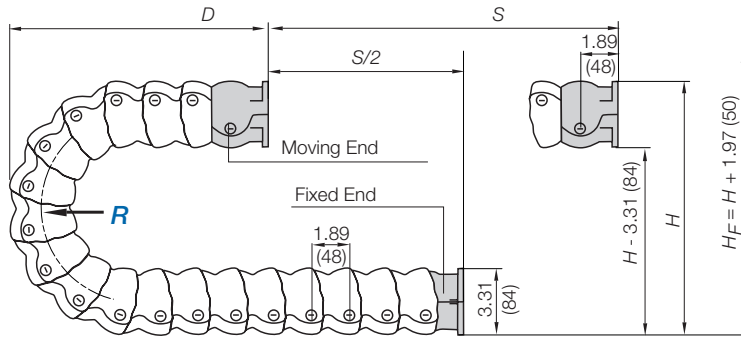
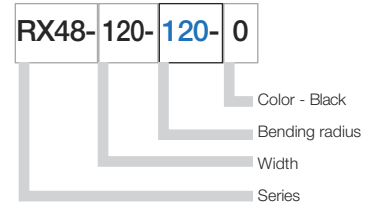

Supplement part number with required radius. Example: RX48-120-**120**-0
Pitch: 1.89 in. (48 mm) per link links/ft(m) = 6.35 (21)

Part Number	Bi in. (mm)	Ba in. (mm)	Weight lbs/ft (kg/m)
RX48-120- <input type="text"/> -0	4.72 (120)	5.81 (147.6)	≈ 1.85 (2.76)

Choose from the radii below for all of the above sizes
Radius (mm) Example: RX48-120-**120**-0

	120	150
R	4.72 (120)	5.91 (150)
H	12.76 (324)	15.12 (384)
D	8.27 (210)	9.45 (240)
K	18.70 (475)	22.44 (570)

Separators and shelves

Vertical separators are used if a vertical subdivision of the Energy Tube interior is required. By standard, vertical separators are assembled every other Energy Tube link.

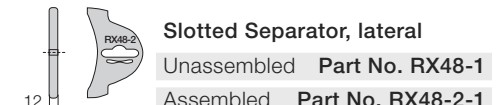
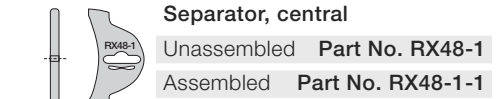
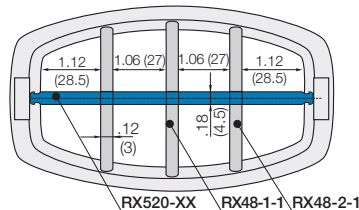

Shelves RX520-XX

Full width shelves lock into separators on both ends, fixed width possible. Separators can be moved freely over the shelf horizontally.

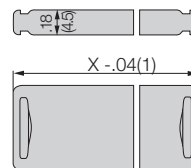

Width X in. (mm)	Part No. Unassembled	Part No. Assembled
1.34 (34)	RX520-34	RX521-24
2.52 (64)	RX520-64	RX521-44
3.70 (94)	RX520-94	RX521-64
4.88 (124)	RX520-124	RX521-84

Energy Chain System® E2 Tubes Series RX48 Mounting Brackets

energy chain® configurator 



RX48



Option: Flange mounting brackets

- Universally mountable with flange attachment capability
- Optional strain relief tiwrap plates
- Easy to open
- Optional M4 insert nuts

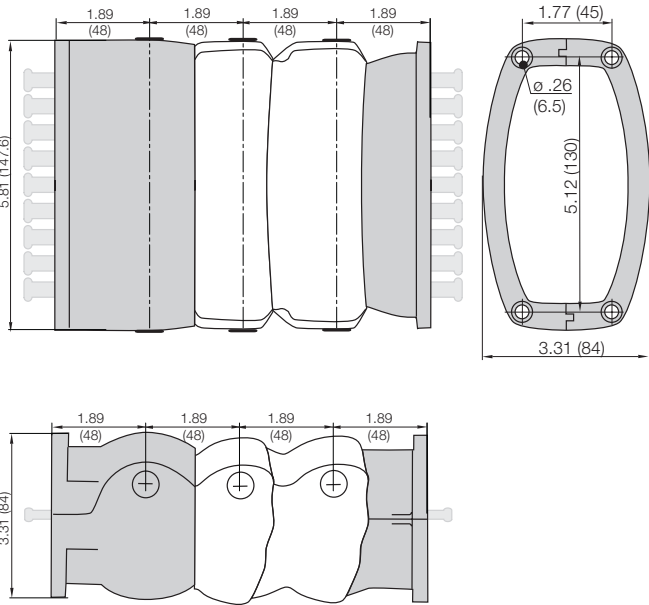
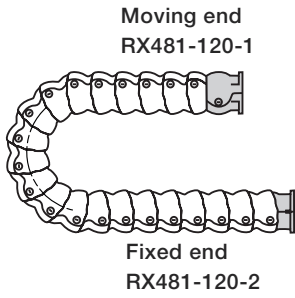

Shown with strain relief



Chain Type	Part No.	Number of Teeth
RX48	RX481-120-12	upon request

Full set, for both ends:

RX481-120-12

Single-part order:

RX481-120-1 Mounting bracket moving end

RX481-120-2 Mounting bracket fixed end

PDF: www.igus.com/echainpdf.asp
Specs/CAD/RFG: www.igus.com/echain.asp
RoHS info: www.igus.com/RoHS.asp



Price Index



Series RX56

Special Features / Options



ESD classification:
Electrically conductive
ESD/ATEX version upon request



Flammability Class
VDE 0304 IIC UL94 HB

Assembly Tips



Easy opening of lids on the outer radius with embedded excentric locking mechanism

Features & Benefits

- 1 Mounting bracket available with or without strain relief
- 2 Full chip protection without undercuts, projecting edges or gaps
- 3 Large interior cross section
- 4 Round contour prevents chip accumulation
- 5 Covered pin/bore connection and stop dogs
- 6 Lids open from outer radius
- 7 Interior separation available



Usage Guidelines



- If a fully protected Energy Tube is desired
- If easy access from the outside is required



- For chip protection in gliding applications
➤ Series R19850 E4 Light

Order Example: Complete Energy Chain®

Please indicate chain length or number of links. Example:

9.84 ft (3 m) RX56-140-140-0



Energy Chain®

With 3 separators RX56-1-1/RX56-1-2 assemb. every 2nd link



Interior Separation

1 Set RX561-140-12



Mounting Bracket

Energy Chain System® E2 Tubes Series RX56 Installation Dimensions

energy chain® configurator ▶

igus®

RX56

Short travel, unsupported length

- FL_B = unsupported with permitted sag
 - FL_G = unsupported with straight upper run
- Further information ▶ Design, Chapter 1

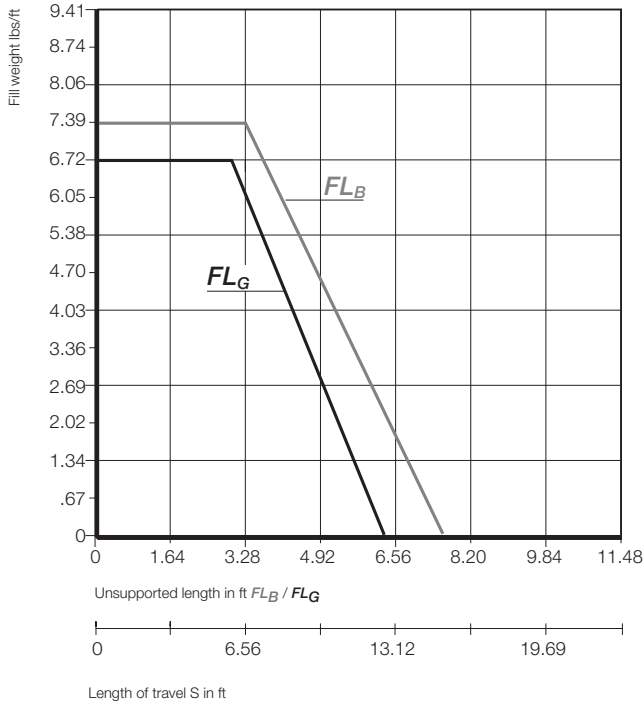
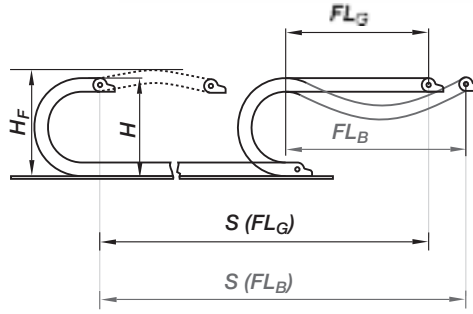

Short Travels - Unsupported



Unsupported Energy Chains® feature positive camber over short travels. This must be accounted for when specifying the clearance height. Please refer to **Installation dimensions** for further details.

Legend

- S = Length of travel
- R = Bending radius
- H = Nominal clearance height
- D = Overlength Energy Chain® radius in final position
- $K = \pi \cdot R + \text{safety buffer}$
- H_F = Required clearance height

2.87

PDF: www.igus.com/echainpdf.asp
Specs/CAD/RFQ: www.igus.com/echain.asp
RoHS info: www.igus.com/RoHS.asp

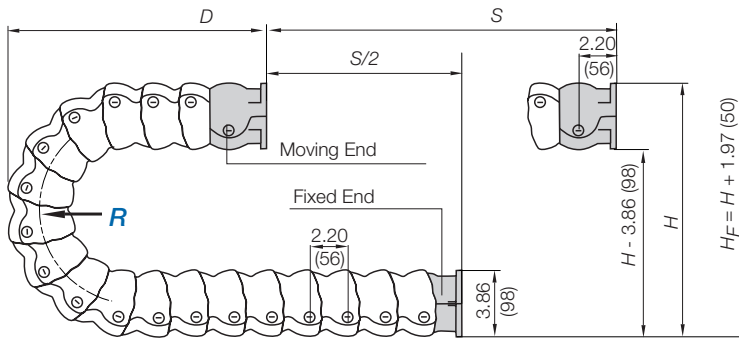

Pitch per link = 2.20" (56 mm)
Links per ft (m) = 5.45 (18)
For center mount applications:
Chain length = $\frac{S}{2} + K$

The required clearance height: $H_F = H + 1.97$ in. (50 mm) (with .34 lbs/ft (0.5 kg/m) fill weight. Please consult igus® if space is particularly restricted.

R	5.51 (140)
H	14.88 (378)
D	9.65 (245)
K	21.85 (555)

Technical Data

Speed / acceleration FL_G	max. 32.8 ft/s (10 m/s) / max. 328 ft/s ² (100 m/s ²)
Speed / acceleration FL_B	max. 9.84 ft/s (3 m/s) / max. 19.69 ft/s ² (6 m/s ²)
Material - permitted temperature	igumid G / -40°F (-40°C) up to +248°F (+120°C)
Flammability Class, igumid G	VDE 0304 IIC UL94 HB



Details of material properties

▶ Chapter 1

5.114

Series RX56 - snap-open along the outer radius

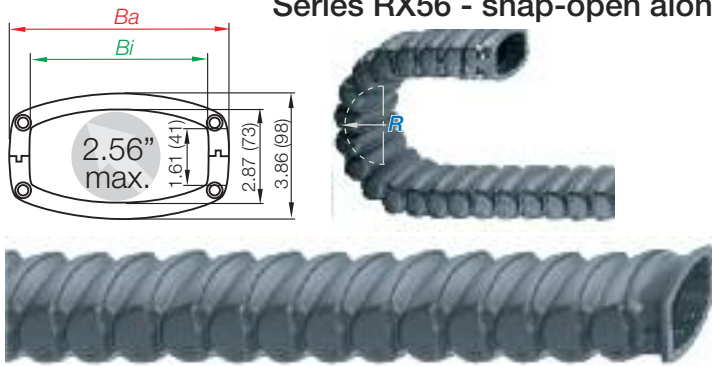

Part Number Structure

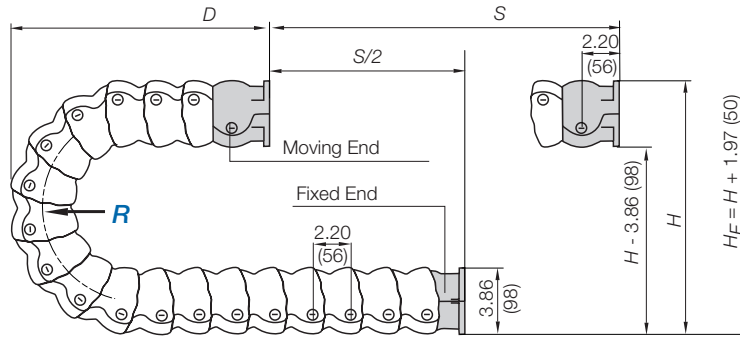
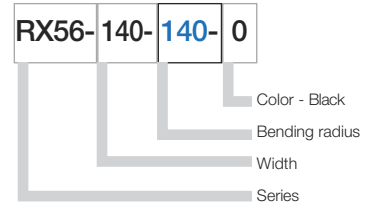

Supplement part number with required radius. Example: RX56-140-**140**-0
Pitch: 2.20 in. (56 mm) per link links/ft(m) = 5.45 (18)

Part Number	Bi in. (mm)	Ba in. (mm)	Weight lbs/ft (kg/m)
RX40-100- <input type="text"/> -0	5.51 (140)	6.78 (172.2)	≈ 2.57 (3.83)

Choose from the radii below for all of the above sizes
Radius (mm) Example: RX56-140--0

R	<input type="text" value="140"/> 5.51 (140)
H	14.88 (378)
D	9.65 (245)
K	21.85 (555)

Separators and shelves

Vertical separators are used if a vertical subdivision of the Energy Tube interior is required. By standard, vertical separators are assembled every other Energy Tube link.

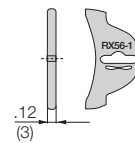
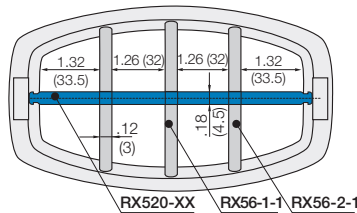

Separator, central

Unassembled Part No. RX56-1
Assembled Part No. RX56-1-1

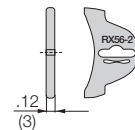

Slotted Separator, lateral

Unassembled Part No. RX56-1
Assembled Part No. RX56-2-1

Shelves RX520-XX

Full width shelves lock into separators on both ends, fixed width possible. Separators can be moved freely over the shelf horizontally.

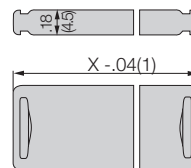

Width X in. (mm)	Part No. Unassembled	Part No. Assembled
1.54 (39)	RX520-39	RX521-39
2.91 (74)	RX520-74	RX521-74
4.29 (109)	RX520-109	RX521-109
5.67 (144)	RX520-144	RX521-144

Energy Chain System® E2 Tubes Series RX56 Mounting Brackets

energy chain® configurator ▶



RX56



Option: Flange mounting brackets

- Universally mountable with flange attachment capability
- Optional strain relief tiwrap plates
- Easy to open
- Optional M4 insert nuts

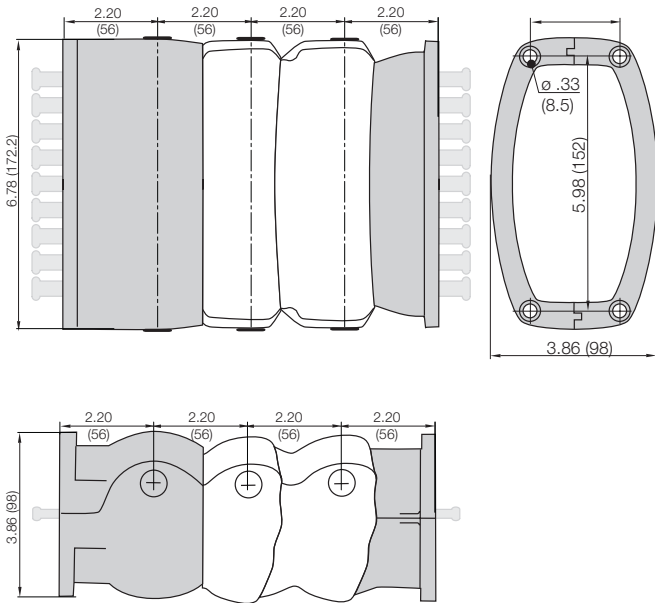
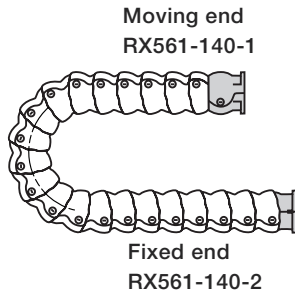

Shown with strain relief



Chain Type	Part No.	Number of Teeth
RX56	RX561-140-12	upon request

Full set, for both ends:

RX561-140-12

Single-part order:

RX561-140-1 Mounting bracket moving end

RX561-140-2 Mounting bracket fixed end

PDF: www.igus.com/echainpdf.asp
Specs/CAD/RFG: www.igus.com/echain.asp
RoHS info: www.igus.com/RoHS.asp

