

Variable Speed Drive Interchange Guide

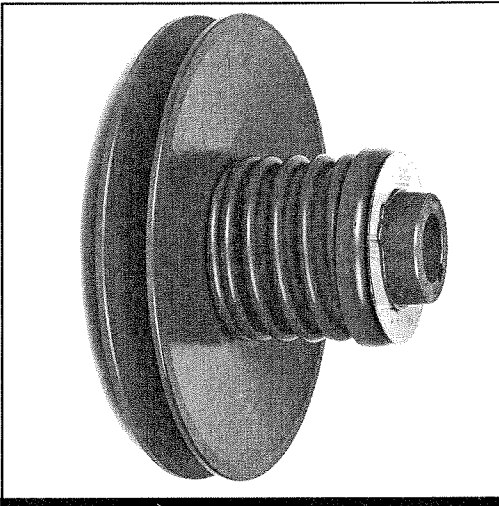

**COMPARED
WITH:**

BROWNING
GERBING
HI-LO
LEWELLEN
MAUREY
REEVES
SPEED SELECTOR
T.B. WOOD'S

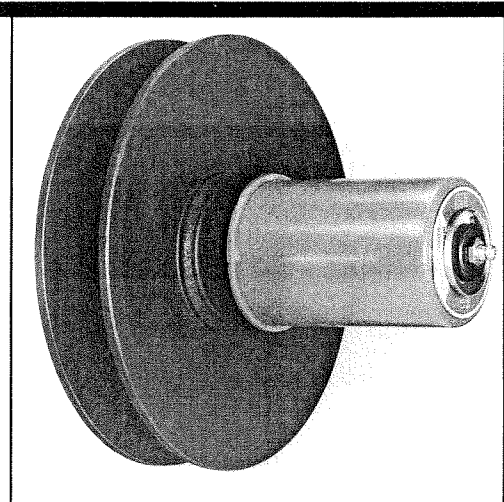

Lovejoy, Inc.
2655 Wisconsin Avenue
Downers Grove, IL 60515
Phone: 630-852-0500 Fax: 630-852-2120
www.lovejoy-inc.com

Variable Speed Pulley Interchange Guide

How to use this Interchange Guide

As the title implies, this is a *guide* to help you select the Lovejoy variable speed pulley most suitable for replacing a product made by one of the other major manufacturers. Unlike bearings and some other power transmission products, these are not always exact interchanges and there may be differences between the pulley you are replacing and the nearest Lovejoy equivalent. Sometimes this difference is insignificant and will not affect the performance of the drive package. For example, the Lovejoy pulley might be slightly shorter in overall length than the other brand, but it will still deliver the same torque and speed range with the same belt. At other times, the difference can be significant enough that the drive package will have to be re-positioned or other components will have to be changed in order to get the same results. For example, replacing a 13 inch diameter motor pulley with a similar pulley that is 12-1/2 inches in diameter will lower the highest available driven speed. There are other critical differences to be concerned with such as horsepower ratings, belt differences, and belt centerline (dimension "C" in the charts). **Please do not recommend any of these interchanges without checking all of the critical dimensions and data in the chart.** Failure to do so could result in unsatisfactory drive performance. If you're not sure, call Lovejoy's Engineering Department for assistance.

Table Of Contents

	Page
Browning Products	1
Gerbing Products	2-3
Hi-Lo Products	4-6
Lewellen Products	7
Maurey Products	7
Reeves Products	8
Speed Selector Products	9-12
T.B. Wood's Products	12-17

Variable Speed Pulley Interchange Guide

BROWNING

"MC" Series

Manually Adjustable Pulleys

MODEL NUMBER		BELT SIZE	*MAXIMUM RATIO	"A"
BROWNING	LOVEJOY			
3MC		4L(A)	3.1:1	3.00
		4L(A)	3.7:1	3.38
		4L(A)	3.7:1	3.38
4MC		4L(A)	3.3:1	4.00
		4L(A)	5.3:1	4.00
5MC		5L(B)	2.0:1	5.00
		5L(B)	7.6:1	5.00
		5L(B)	7.6:1	5.00
6MC		5L(B)	1.8:1	6.00
		5L(B)	5.8:1	6.00
		5L(B)	5.8:1	6.00

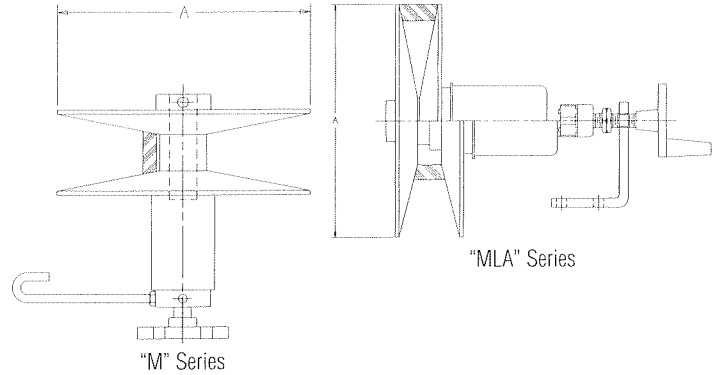

* Ratio will vary depending upon which companion spring-loaded pulley is being used.

BROWNING

"SL" Series

1-Side Moveable
Spring Loaded Pulleys

MODEL NUMBER		HP @ 1750 RPM	BELT SIZE	RATIO	"A"	"B"	"C"	"D"	"E"
BROWNING	LOVEJOY								
3SL		1/3	4L(A)	1.75:1	3.00	2.50	.91	.72	2.44
		3403	1/3	4L(A)	1.9:1	3.38	2.81	.94	.75
4SL		1/2	4L(A)	1.8:1	4.00	2.75	1.03	.78	2.94
		4005	1/2	4L(A)	2.3:1	4.00	2.81	.94	.75
5SL		1	5L(B)	1.5:1	5.00	3.94	1.03	.78	3.56
		5010	1	5L(B)	2.7:1	5.00	3.50	1.09	.81
6SL		1-1/2	5L(B)	1.4:1	6.00	3.94	1.03	.78	3.56
		6020	2	5L(B)	2.1:1	6.00	4.13	1.19	.95

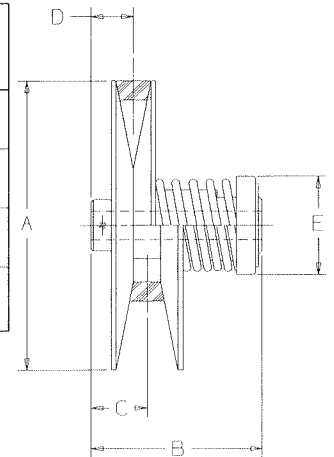

BROWNING

Wide Range Variable Speed Sheaves

MODEL NUMBER		BELT SIZE	P.D. RANGE		"A"	"B"	
BROWNING	LOVEJOY		MIN. P.D.	MAX. P.D.			
49R97		2530V	4.90	9.70	9.95	5.38	
		LAS 25-10.25	2530V	5.00	9.95	10.25	5.38
49W110		4430V	4.90	11.00	11.25	6.13	
		LAS 44-10.75	4430V	4.84	10.35	10.75	7.38
		LAS 44-12.50	4430V	4.84	12.10	12.50	7.38

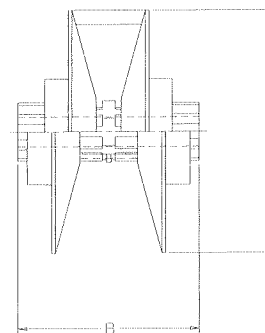

GERBING

"Roto-Cone" Series

2-Side Moveable
Spring Loaded Pulleys

MODEL NUMBER		HP @ 1750 RPM	BELT SIZE	RATIO	"A"	"B"	"C"	"D"
GERBING	LOVEJOY							
55		1/2	1422V	3.0:1	5.50	4.75	1.00	2.06
	245	1/2	1422V	3.0:1	6.00	4.86	1.31	2.25
60*		3/4	1922V	3.0:1	6.00	5.75	.94	2.25
	260*	3/4	1422V	3.0:1	6.00	4.86	1.31	2.25
75		1-1/2	1922V	3.0:1	7.50	7.13	1.25	2.63
	301E	1 to 1-1/2	1922V	3.0:1	7.50	7.13	1.56	2.50
80		3	2322V	3.0:1	8.00	8.00	1.44	2.87
	3030E	3	2322V	3.0:1	8.50	8.75	2.00	2.87
105		3	2926V	4.0:1	10.62	8.00	1.81	2.87
	403E	3	2926V	3.8:1	11.00	8.75	1.81	2.87
100		5	2926V	3.0:1	10.00	10.44	2.06	3.63
	3050E	5	2926V	3.0:1	10.00	10.31	2.13	3.19
125		7-1/2	4430V	3.0:1	12.50	11.50	2.13	4.25
	3075B	7-1/2	4430V	3.0:1	13.00	13.44	2.50	4.00
1307		7-1/2	4430V	3.0:1	13.00	12.56	2.25	4.50
	3075B	7-1/2	4430V	3.0:1	13.00	13.44	2.50	4.00
1310		10	4430V	3.0:1	13.00	12.56	2.25	4.50
	3100B	10	4430V	3.0:1	13.00	13.44	2.50	4.00
1315		15	4430V	3.0:1	13.00	12.56	2.25	4.50
	3150B	15	4430V	3.0:1	13.00	13.44	2.50	4.00

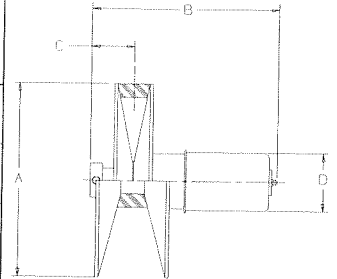

* Not an ideal interchange due to the difference in the belt width. For best performance, you should consider replacing the entire drive.

If any of the above Gerbing model numbers contain a "W" or "A" suffix, it is a manually adjustable pulley. These are not directly interchangeable with Lovejoy. The entire drive will need to be replaced. Call Lovejoy Engineering for assistance.

GERBING

"Var-A-Cone" Series

Manually Adjustable Pulleys

MODEL NUMBER		BELT SIZE	*MAXIMUM RATIO	"A"
GERBING	LOVEJOY			
30A		4L(A)	4.0:1	3.38
	MLA-34	4L(A)	3.6:1	3.38
	M-34	4L(A)	3.6:1	3.38
40A		4L(A)	5.6:1	4.00
	MLA-40	4L(A)	4.8:1	4.00
51A		5L(B)	7.5:1	5.00
	MLA-50	5L(B)	5.7:1	5.00
	M-50	5L(B)	5.7:1	5.00
57A		5L(B)	5.8:1	5.75
	MLA-60	5L(B)	4.7:1	6.00
	M-60	5L(B)	4.7:1	6.00

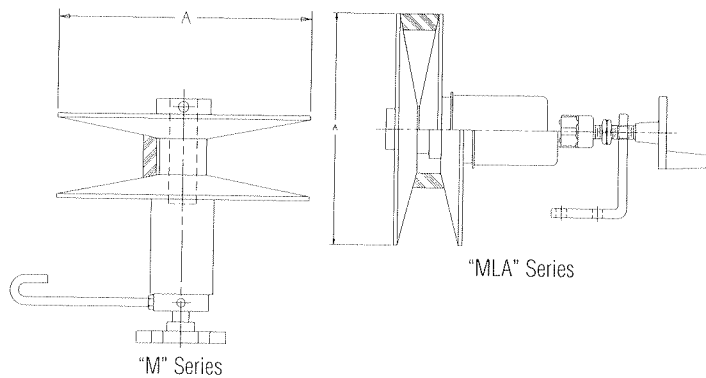

* Ratio will vary depending upon which companion spring-loaded pulley is being used.

See pg. 3 for the interchange of the companion "1-Side Moveable" Spring Loaded Pulleys.

Variable Speed Pulley Interchange Guide



GERBING

“Var-A-Cone” Series

1-Side Moveable
Spring Loaded Pulleys

MODEL NUMBER		HP @ 1750 RPM	BELT SIZE	RATIO	“A”	“B”	“C”	“D”	“E”
GERBING	LOVEJOY								
30		1/3	4L(A)	2.0:1	3.38	2.81	.94	.75	2.13
	3403	1/3	4L(A)	1.9:1	3.38	2.81	.94	.75	2.16
40		1/2	4L(A)	2.4:1	4.00	2.81	.94	.75	2.13
	4005	1/2	4L(A)	2.3:1	4.00	2.81	.94	.75	2.16
51		3/4	5L(B)	2.8:1	5.00	3.50	1.09	.81	2.13
	5010	1	5L(B)	2.7:1	5.00	3.50	1.09	.81	2.50
57		1-1/2	5L(B)	2.3:1	5.75	4.38	1.19	.95	2.25
	6020	2	5L(B)	2.1:1	6.00	4.13	1.19	.95	3.13

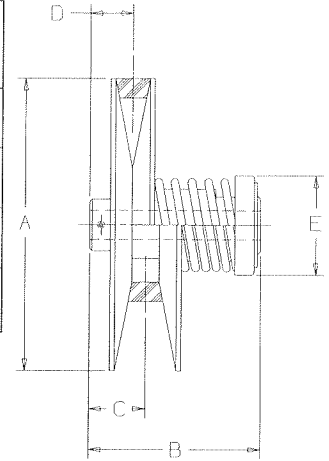

GERBING

“Quadra-Key” Series

2-Side Moveable
Spring Loaded Pulleys

MODEL NUMBER		HP @ 1750 RPM	BELT SIZE	RATIO	“A”	“B”	“C”	“D”
GERBING	LOVEJOY							
2303		3	2322V	3.0:1	9.05	5.75	2.88	5.40
	3030E ¹	3	2322V	3.0:1	8.50	8.75	2.00	2.87
2305*		5	2322V	3.0:1	9.05	5.75	2.88	5.40
	22905*	5	2926V	3.0:1	10.00	8.25	4.31	6.62
2905		5	2926V	3.0:1	10.50	7.48	3.74	5.40
	22905	5	2926V	3.0:1	10.00	8.25	4.31	6.62
2907		7-1/2	2926V	3.0:1	10.50	7.48	3.74	5.40
	22907	7-1/2	2926V	3.0:1	10.00	8.25	4.31	6.62
2910*		10	2926V	3.0:1	10.50	7.48	3.74	5.40
	23210*	10	3230HV	2.3:1	10.75	9.38	5.00	6.62
4410 (Alum)		10	4430V	3.0:1	13.00	9.60	4.80	6.67
4411 (CI)		10	4430V	3.0:1	13.00	9.60	4.80	6.67
	24410	10	4430V	2.7:1	12.50	10.13	5.38	6.62
4415 (Alum)		15	4430V	3.0:1	13.00	9.60	4.80	6.67
4416 (CI)		15	4430V	3.0:1	13.00	9.60	4.80	6.67
	24420	15 to 20	4430V	2.7:1	12.50	10.13	5.38	6.62
4420 (Alum)		20	4430V	3.0:1	13.00	9.60	4.80	6.67
4421 (CI)		20	4430V	3.0:1	13.00	9.60	4.80	6.67
	24420	15 to 20	4430V	2.7:1	12.50	10.13	5.38	6.62
4426		25	4430V	3.0:1	13.00	9.60	4.80	6.67
	24430	25 to 30	4430V	2.7:1	12.50	10.13	5.38	6.62
4431		30	4430V	3.0:1	13.00	9.60	4.80	6.67
	24430	25 to 30	4430V	2.7:1	12.50	10.13	5.38	6.62

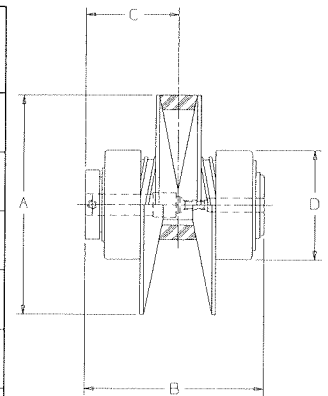

* Not an ideal interchange due to the difference in the belt width or angle. For best performance, you should consider replacing the entire drive.

(Alum) - Aluminum Flanges
(CI) - Cast Iron Flanges

¹ Requires sheave re-alignment.

HI-LO

"TBR" Series

1-Side Moveable

Spring Loaded Pulleys

MODEL NUMBER		HP @ 1750 RPM	BELT SIZE	RATIO	"A"	"B"	"C"	"D"	"E"
HI-LO	LOVEJOY								
30TBR	3407	3/4	4L(A)	2.0:1	3.38	2.69	.97	.78	3.06
		3/4	4L(A)	1.9:1	3.38	2.81	.94	.75	2.16
40TBR	4010	1	4L(A)	2.5:1	4.25	2.69	.97	.78	3.06
		1	4L(A)	2.3:1	4.00	2.81	.94	.75	2.16
50TBR	5015	1-1/2	5L(B)	2.7:1	5.00	3.06	1.01	.78	4.06
		1-1/2	5L(B)	2.7:1	5.00	3.50	1.09	.81	2.50
57-20TBR	6020	2	5L(B)	2.5:1	5.75	3.06	1.01	.78	4.06
		2	5L(B)	2.1:1	6.00	4.13	1.19	.95	3.13
57TBR	6030	3	5L(B)	2.5:1	5.75	3.88	1.33	1.09	5.07
		3	5L(B)	2.1:1	6.00	4.13	1.19	.95	3.13
66TBR	7050	5	5L(B)	2.0:1	6.63	3.88	1.33	1.09	5.07
		5	5L(B)	1.8:1	7.00	4.13	1.19	.95	3.13
86TBR	8250	5	5L(B)	1.6:1	8.63	3.88	1.33	1.09	5.07
		5	5L(B)	1.6:1	8.25	4.38	1.23	1.02	3.13

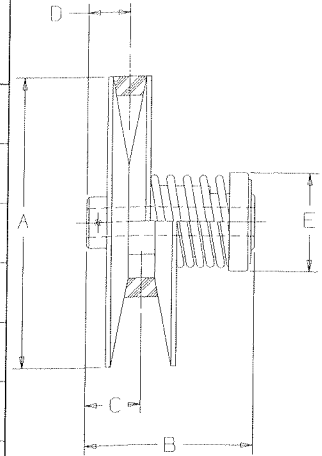

HI-LO

"DCW" Series

2-Side Moveable

Spring Loaded Pulleys

MODEL NUMBER		HP @ 1750 RPM	BELT SIZE	RATIO	"A"	"B"	"C"	"D"
HI-LO	LOVEJOY							
1160	21401	1 to 1-1/2	1422V	3.0:1	6.13	4.38	2.19	4.06
		1	1422V	2.6:1	6.00	4.63	2.50	2.88
1270	21903	3	1922V	3.0:1	7.50	5.88	2.87	5.07
		3	1922V	3.0:1	8.25	6.75	3.63	3.00
1590*	22905*	5	2322V	3.0:1	9.00	7.06	3.53	7.13
		5	2926V	3.0:1	10.00	8.25	4.31	6.63
1711*	23210*	10	3226V	3.0:1	11.00	8.66	4.33	7.13
		10	3230HV	2.3:1	10.75	9.38	5.00	6.63
2011	23220	20	3230HV	2.5:1	11.00	9.75	4.88	7.13
		15 to 20	3230HV	2.3:1	10.75	9.38	5.00	6.63
2513	24430	30	4430V	3.0:1	13.00	9.75	4.88	7.13
		25 to 30	4430V	2.7:1	12.50	10.13	5.38	6.63

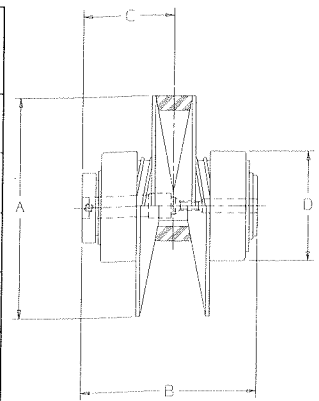

* Not an ideal interchange due to the difference in the belt width or angle. For best performance, you should consider replacing the entire drive.

HI-LO

"DCV" Series

2-Side Moveable
Spring Loaded Pulleys

MODEL NUMBER		HP @ 1750 RPM	BELT SIZE	RATIO	"A"	"B"	"C"	"D"
HI-LO	LOVEJOY							
140*		1	4L(A)	2.3:1	4.00	4.38	2.19	4.06
	2510*	1	5L(B)	2.5:1	5.00	4.06	2.18	2.67
150		1-1/2	5L(B)	2.5:1	5.00	4.38	2.19	4.06
	2515	1-1/2	5L(B)	2.3:1	5.00	4.06	2.18	2.67
157-20		2	5L(B)	2.2:1	5.75	4.38	2.19	4.06
	2620	2	5L(B)	2.1:1	6.00	5.06	2.53	3.13
157		3	5L(B)	2.2:1	5.75	4.94	2.50	5.07
	2630	3	5L(B)	2.1:1	6.00	5.06	2.53	3.13
167		5	5L(B)	2.5:1	6.88	5.88	2.88	5.07
	2750	5	5L(B)	1.8:1	7.00	5.06	2.53	3.13

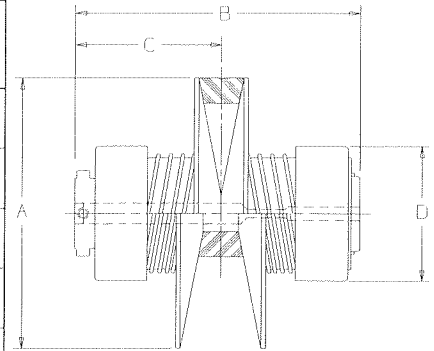

* Not an ideal interchange due to the difference in the belt width or angle. For best performance, you should consider replacing the entire drive.

Lovejoy Pulley Pledge Program

One of the keys of selling variable speed pulleys is product availability. Lovejoy has just made that job a little easier. Now, you are **guaranteed** the pulley required is available within 24 hours. The Lovejoy Pulley Pledge is simple but direct: each Lovejoy warehouse will be stocked with that region's most popular standard variable speed drive products as designated by a "+" in the Lovejoy Price Book or Lovejoy will ship your order next day air at no additional charge! Orders must be placed by 2:00 pm Central Time for one piece of a variable speed pulley, adjustable motor base or companion sheave. No more unnecessary downtime, no production delays because the pulley needed is out of stock. Please contact your local Lovejoy distributor or Lovejoy Customer Service for complete details.

HI-LO

"MCV" & "MCW" Series

Fixed Center Drives

DRIVER PULLEY MODEL NUMBER		DRIVEN PULLEY MODEL NUMBER		HP @ 1750 RPM (DRIVER)	BELT SIZE	DRIVEN SPEED RANGE (1750 RPM DRIVER)		"A" DRIVER O.D.	"B" DRIVEN O.D.	"C" OFFSET
HI-LO	LOVEJOY	HI-LO	LOVEJOY			MIN	MAX			
MCV30	M-34	30TBR	3405R	1/2	4L(A)	875	3500	3.38	3.38	.93
		40TBR		1/2	4L(A)	910	3380	3.38	3.38	1.12
			4007R	3/4	4L(A)	687	2106	3.38	4.25	.93
				3/4	4L(A)	760	2300	3.38	4.00	1.12
MCV500 MCV50	M-50	50TBR	5010R	1	5L(B)	647	4625	5.00	5.00	1.27
				1	5L(B)	610	4640	5.00	5.00	1.62
		57-20TBR	6020R	2	5L(B)	557	3014	5.00	5.75	1.27
			6020R	2	5L(B)	500	2760	5.00	6.00	2.12
		66TBR	7020R	2	5L(B)	485	2248	5.00	6.62	1.77
			7020R	2	5L(B)	430	1940	5.00	7.00	2.12
		86TBR	8220R	2	5L(B)	367	1408	5.00	8.62	1.77
				2	5L(B)	360	1440	5.00	8.25	2.30
MVC57	M-60	57TBR	6030R	3	5L(B)	648	4500	5.75	5.75	1.38
				3	5L(B)	730	3500	6.00	6.00	1.95
		66TBR	7030R	3	5L(B)	564	3214	5.75	6.62	1.38
			7030R	3	5L(B)	620	2660	6.00	7.00	1.95
		86TBR	8250R	5	5L(B)	427	1750	5.75	8.62	1.38
				5	5L(B)	520	1910	6.00	8.25	2.12
MCW600	M-14	60TBR	1401	1	1422V	550	5500	6.12	6.12	1.51
				1/2 to 1	1422V	430	3658	6.00	7.00	1.59
MCW600*	M-19*	75TBR*	1902*	1-1/2	1422V	400	3000	6.12	7.50	1.51
				1 to 2	1922V	403	4630	7.50	8.25	1.81
MCW70	M-19	80TBR	1902	2	1922V	423	4075	6.20	6.12	1.51
				1 to 2	1922V	403	4630	7.50	8.25	1.81
		90-19TBR	1903	3	1922V	375	2863	6.20	9.00	1.51
			1903	3	1922V	403	4275	7.50	8.25	1.81
MCW77	M-19	90-19TBR	1903	3	1922V	450	3470	7.75	9.00	2.44
				3	1922V	403	4275	7.50	8.25	1.81
		110TBR	2305*	5	1922V	365	2108	7.75	11.00	2.44
			2305*	5	2322V	346	4197	9.50	11.00	1.40
MCW90	M-23	90-23TBR	2303	3	2322V	450	4500	9.00	9.00	2.56
				3	2322V	346	4197	9.50	11.00	1.40
		106TBR	2305	5	2322V	380	3420	9.00	10.60	2.56
			2305	5	2322V	346	4197	9.50	11.00	1.40
		120TBR	2305	5	2322V	336	2490	9.00	12.00	2.56
		2305	5	2322V	346	4197	9.50	11.00	1.40	
MCW-90-75*	HM-7*	120TBR*	32905*	7-1/2	2322V	336	2397	9.00	12.00	2.56
				7-1/2	2926V	590	4005	10.00	10.00	1.89

* Not an ideal interchange due to the difference in the belt width or angle. For best performance, you should consider replacing the entire drive.

These interchange suggestions are only to be used to replace a complete belt drive system. Do not attempt to replace just one part of the drive with a different manufacturer's pulley.

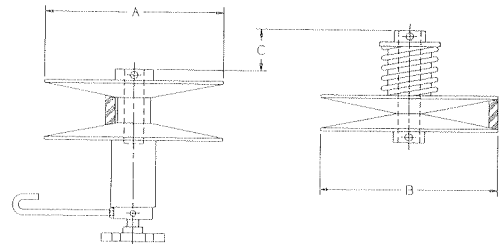

"M" Series

Variable Speed Pulley Interchange Guide



LEWELLEN

"400" Series

2-Side Moveable
Spring Loaded Pulleys

MODEL NUMBER		HP @ 1750 RPM	BELT SIZE	RATIO	"A"	"B"	"C"	"D"
LEWELLEN	LOVEJOY							
406		1/2 to 3/4	1422V	3.0:1	5.75	5.19	1.13	2.25
	245	1/2	1422V	3.0:1	6.00	4.86	1.31	2.25
	260	3/4	1422V	3.0:1	6.00	4.86	1.31	2.25
408		1 to 1-1/2	1922V	3.0:1	7.75	6.19	1.38	2.87
	301E	1 to 1-1/2	1922V	3.0:1	7.50	7.13	1.56	2.50
409		2 to 3	2322V	3.0:1	9.00	7.00	1.50	3.19
	3030E	3	2322V	3.0:1	8.50	8.75	2.00	2.87
411		2 to 3	2926V	4.0:1	11.00	8.13	1.75	3.19
	402E	2	2926V	3.8:1	11.00	8.75	1.81	2.87
	403E	3	2926V	3.8:1	11.00	8.75	1.81	2.87
410*		5	3230HV	3.0:1	10.00	8.56	1.87	3.75
	3050E*	5	2926V	3.0:1	10.00	10.31	2.13	3.19
410/B*		7-1/2	3230HV	3.0:1	10.00	8.56	1.87	3.75
	3050E-HD*	7-1/2	2926V	3.0:1	10.00	10.31	2.13	3.19
412		10	4430V	3.0:1	12.00	10.69	2.38	4.38
	3100B	10	4430V	3.0:1	13.00	13.44	2.50	4.00
412/15		15	4430V	3.0:1	12.00	10.69	2.38	4.38
	3150B	15	4430V	3.0:1	13.00	13.44	2.50	4.00

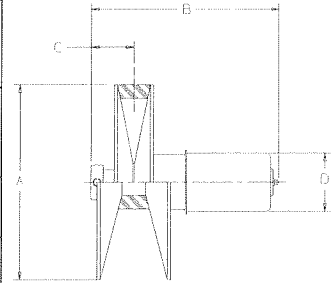

* Not an ideal interchange due to the difference in the belt width or angle. For best performance, you should consider replacing the entire drive.

MAUREY

"FHP" Series

1-Side Moveable
Spring Loaded Pulleys

MODEL NUMBER		HP @ 1750 RPM	BELT SIZE	RATIO	"A"	"B"	"C"	"D"	"E"
MAUREY	LOVEJOY								
6325		1/3	4L(A)	1.6:1	3.25	2.38	N/A	.72	2.31
	3403	1/3	4L(A)	1.9:1	3.38	2.81	.94	.75	2.16
6400		1/2	4L(A)	2.0:1	4.00	2.38	N/A	.72	2.31
	4005	1/2	4L(A)	2.3:1	4.00	2.81	.94	.75	2.16
6500		3/4 to 1	5L(B)	2.0:1	5.00	3.62	N/A	.96	3.18
	5010	1	5L(B)	2.7:1	5.00	3.50	1.09	.81	2.50
6600		1	5L(B)	2.1:1	6.00	3.88	N/A	.96	3.18
	6010	1	5L(B)	2.1:1	6.00	4.13	1.19	.95	3.13
66150		1-1/2	5L(B)	2.1:1	6.00	3.88	N/A	.96	3.18
	6020	2	5L(B)	2.1:1	6.00	4.13	1.19	.95	3.13
66200		2	5L(B)	2.1:1	6.00	3.88	N/A	.96	3.18
	6020	2	5L(B)	2.1:1	6.00	4.13	1.19	.95	3.13

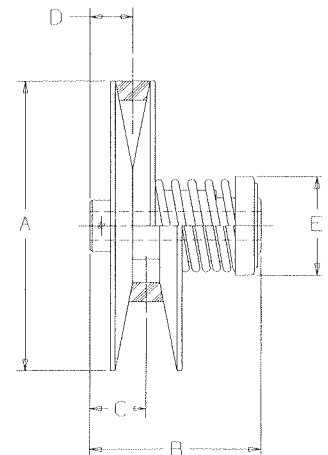

REEVES

“Sr. Pulley” Series

1-Side Moveable
Spring Loaded Pulleys

MODEL NUMBER		HP @ 1750 RPM	BELT SIZE	RATIO	“A”	“B”	“C”	“D”	“E”
REEVES	LOVEJOY								
5675		3/4	1422V	3.0:1	5.44	5.12	N/A	N/A	2.44
	11407	3/4	1422V	2.6:1	6.00	3.56	1.38	1.00	2.88
7202		1 to 2	1922V	3.0:1	7.01	6.04	N/A	N/A	3.13
	11902	2	1922V	3.0:1	8.25	5.38	1.88	1.38	3.00
9205		3 to 5	2926V	3.0:1	8.96	7.75	N/A	N/A	3.69
	12905	5	2926V	3.0:1	10.00	6.44	2.62	1.88	6.63
1110		7-1/2 to 10	4430V	3.0:1	11.09	10.08	N/A	N/A	5.00
	14410	10	4430V	2.7:1	12.50	8.62	3.44	2.38	6.63
912-15		15	4430V	2.0:1	12.00	11.31	N/A	N/A	4.28
	14420	15 to 20	4430V	2.7:1	12.50	8.62	3.44	2.38	6.63

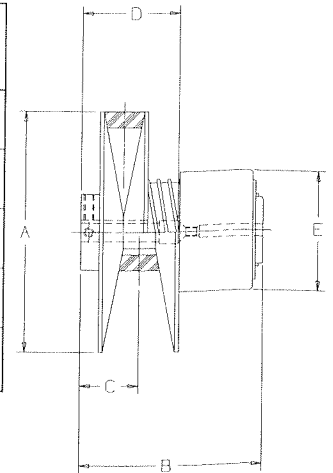

REEVES

“Jr. Pulley” Series

1-Side Moveable
Spring Loaded Pulleys

MODEL NUMBER		HP @ 1750 RPM	BELT SIZE	RATIO	“A”	“B”	“C”	“D”	“E”
REEVES	LOVEJOY								
830		1/4 to 1/3	4L(A)	1.7:1	3.75	3.69	N/A	N/A	2.16
	3403	1/4 to 1/3	4L(A)	1.9:1	3.38	2.81	.94	.75	2.16
850		1/2	4L(A)	2.2:1	5.13	4.97	N/A	N/A	2.16
	5005A	1/2	4L(A)	1.8:1	5.00	3.50	.92	.75	2.50
860		3/4	4L(A)	2.7:1	6.16	5.88	N/A	N/A	2.16
	170*	3/4	4L(A)	2.5:1	6.31	7.13	1.63	1.63	2.50
	5010A	3/4 to 1	4L(A)	1.8:1	5.00	3.50	.92	.75	2.50
870		1	5L(B)	2.5:1	7.16	6.88	N/A	N/A	2.78
	7010	1	5L(B)	1.8:1	7.00	4.13	1.19	.95	3.13
875		1-1/2	5L(B)	2.5:1	7.66	7.09	N/A	N/A	2.78
	180*	1-1/2	5L(B)	2.5:1	6.31	7.13	1.63	1.63	2.50
	7020	2	5L(B)	1.8:1	7.00	4.13	1.19	.95	3.13
	8220	2	5L(B)	1.6:1	8.25	4.38	1.23	1.02	3.13

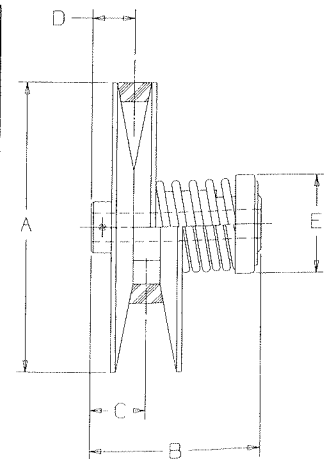

* These pulley models are 2-side moveable aluminum construction

SPEED SELECTOR

"Series 21"

Fixed Center Drives

DRIVER PULLEY MODEL NUMBER		DRIVEN PULLEY MODEL NUMBER		HP @ 1750 RPM (DRIVER)	BELT SIZE	DRIVEN SPEED RANGE (1750 RPM DRIVER)		"A" DRIVER O.D.	"B" DRIVEN O.D.	"C" OFFSET
SPEED SELECTOR	LOVEJOY	SPEED SELECTOR	LOVEJOY			MIN	MAX			
3C	MLA/M-34*	3M	3403R			1/4	4L(A)			
		4M	4005R	1/3	4L(A)	910	3380	3.38	3.38	1.12
				1/4	4L(A)	789	2152	3.12	4.00	.53
4C	MLA-40*	4M	4005R	1/2	4L(A)	760	2300	3.38	4.00	1.12
				1/2	4L(A)	875	3500	4.00	4.00	.50
5C	MLA/M-50*	5M	5010R	3/4	4L(A)	715	4290	5.00	5.00	.56
				1	5L(B)	610	4640	5.00	5.00	1.62
		6M	6010R	3/4	4L(A)	585	2710	5.00	6.00	1.00
				1	5L(B)	500	2760	5.00	6.00	2.12
		7M	7010R	3/4	4L(A)	535	2130	5.00	7.00	1.38
1	5L(B)			430	1940	5.00	7.00	2.12		
6C	MLA/M-60*	6M	6010R	3/4	4L(A)	455	1595	5.00	8.12	2.38
				1	5L(B)	360	1440	5.00	8.25	2.30
		7M	7010R	1	4L(A)	685	4650	6.00	6.00	.81
				1	5L(B)	730	3500	6.00	6.00	1.95
8-1-M	8210R	1	4L(A)	630	3160	6.00	7.00	1.19		
		1	5L(B)	620	2660	6.00	7.00	1.95		
7C	MLA/M-70*	7M	7020R	1	4L(A)	535	2310	6.00	8.12	2.00
				1	5L(B)	520	1910	6.00	8.25	2.12
		8-1-M	8220R	2	5L(B)	685	4450	7.00	7.00	.88
				2	5L(B)	880	3020	7.00	7.00	1.95
8-1-C	MLA/M-70*	8-1-M	8250R	2	5L(B)	608	3040	7.00	8.12	1.88
				2	5L(B)	750	2360	7.00	8.25	2.12
8-1-C	MLA/M-70*	8-1-M	8250R	5	5L(B)	645	4820	8.12	8.12	1.56
				5	5L(B)	750	2360	7.00	8.25	2.13

* The Lovejoy "MLA" Series Pulleys require a Lovejoy #76 Control Stand to actuate the pulley. The "M" Series Pulleys have a built in adjusting screw and handwheel for speed adjustment.

These interchange suggestions are only to be used to replace a complete belt drive system. Do not attempt to replace just one part of the drive with a different manufacturer's pulley.

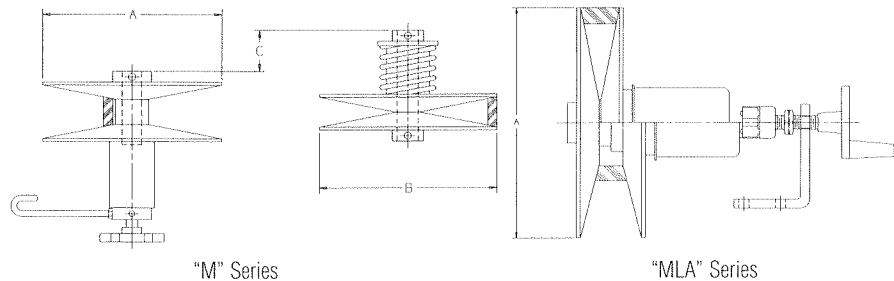

SPEED SELECTOR

"Series 21"

Adjustable Center Drives
Spring Loaded Pulleys

MODEL NUMBER		1750 RPM	HP @ BELT SIZE	RATIO	"A"	"B"	"C" MIN. P.D.	"D" MAX. P.D.	"E"
SPEED SELECTOR	LOVEJOY								
3M	3402	1/4	4L(A)	2.0:1	3.12	2.44	1.50	1.65	1.25
		1/4	4L(A)	1.9:1	3.38	2.81	.94	.75	2.16
4M	4005	1/2	4L(A)	2.0:1	4.00	2.25	1.28	1.44	1.68
		1/2	4L(A)	2.3:1	4.00	2.81	.94	.75	2.16
5M	5010A	3/4	4L(A)	2.5:1	5.00	3.62	1.38	1.68	1.68
		1	4L(A)	1.8:1	5.00	3.50	.92	.75	2.50
6M	6020	1-1/2	4L(A)	2.6:1	6.00	4.68	1.75	2.13	2.25
		1-1/2 to 2	5L(B)	2.1:1	6.00	4.13	1.19	.95	3.13
7M	7020	2	5L(B)	2.8:1	7.00	4.65	2.00	2.53	2.38
		2	5L(B)	1.8:1	7.00	4.13	1.19	.95	3.13
8-1-M	8250	5	5L(B)	2.8:1	8.12	6.44	2.62	3.31	2.88
		5	5L(B)	1.6:1	8.25	4.38	1.23	1.02	3.13

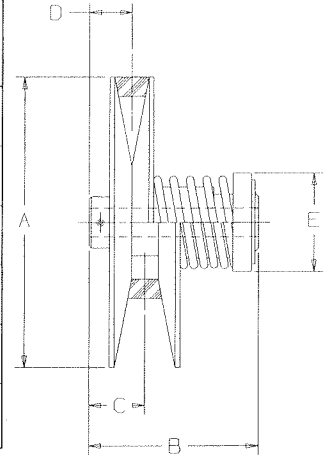

SPEED SELECTOR

"Series 800"

1-Side Moveable
Spring Loaded Pulleys

MODEL NUMBER		HP @ 1750 RPM	BELT SIZE	RATIO	"A"	"B"	"C"	"D"	"E"
SPEED SELECTOR	LOVEJOY								
816	11407 11401	1/2 to 1	1422V	3.0:1	6.50	4.38	1.90	1.53	4.18
		1/2 to 3/4	1422V	2.6:1	6.00	3.56	1.38	1.00	2.87
		1	1422V	2.6:1	6.00	3.56	1.38	1.00	2.87
827	11901 11902 11903	1-1/2 to 3	1922V	3.0:1	7.75	5.25	1.80	1.31	4.62
		1-1/2	1922V	3.0:1	8.25	5.38	1.87	1.38	3.00
		2	1922V	3.0:1	8.25	5.38	1.87	1.38	3.00
		3	1922V	3.0:1	8.25	5.38	1.87	1.38	3.00
859	3030D 12905*	3 to 5	2322V	3.0:1	9.50	6.50	1.90	1.31	5.87
		3	2322V	3.0:1	8.50	8.75	1.81	1.18	2.87
		5	2926V	3.0:1	10.00	6.44	2.62	1.87	6.62
810*	13207* 13210*	7-1/2 to 10	3226V	3.0:1	10.50	7.94	2.31	1.53	7.00
		7-1/2	3230HV	2.3:1	10.75	7.88	3.00	2.25	6.62
		10	3230HV	2.3:1	10.75	7.88	3.00	2.25	6.62
821	14420	15 to 20	4430V	3.0:1	12.00	9.03	3.09	2.06	7.00
		15 to 20	4430V	2.7:1	12.50	8.62	3.44	2.38	6.62
833	14430	25 to 30	4430V	3.0:1	13.00	9.34	2.97	1.84	6.94
		25 to 30	4430V	2.7:1	12.50	8.62	3.44	2.38	6.62

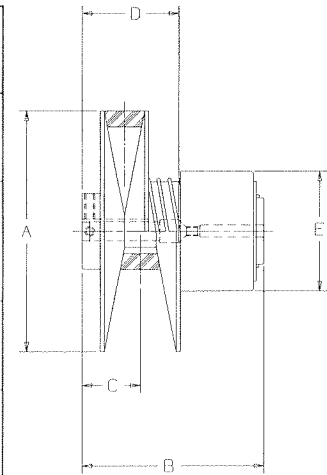

* Not an ideal interchange due to the difference in the belt width or angle. For best performance, you should consider replacing the entire drive.

Variable Speed Pulley Interchange Guide



SPEED SELECTOR

“Series 8800”

2-Side Moveable

Spring Loaded Pulleys

MODEL NUMBER		HP @ 1750 RPM	BELT SIZE	RATIO	“A”	“B”	“C”	“D”
SPEED SELECTOR	LOVEJOY							
8816		1/2 to 1	1422V	3.0:1	6.50	4.38	2.34	4.18
	21407	1/2 to 3/4	1422V	2.6:1	6.00	4.62	2.50	2.87
	21401	1	1422V	2.6:1	6.00	4.62	2.50	2.87
8827		1-1/2 to 3	1922V	3.0:1	7.75	5.25	2.81	4.62
	21901	1-1/2	1922V	3.0:1	8.25	6.75	3.62	3.00
	21902	2	1922V	3.0:1	8.25	6.75	3.62	3.00
	21903	3	1922V	3.0:1	8.25	6.75	3.62	3.00
8859		3 to 5	2322V	3.0:1	9.50	6.50	3.41	5.87
	3030E ¹	3	2322V	3.0:1	8.50	8.75	2.00	2.87
	22905*	5	2926V	3.0:1	10.00	8.25	4.31	6.62
8810		7-1/2 to 10	3226V	3.0:1	10.50	7.94	4.12	7.00
	23207*	7-1/2	3230HV	2.3:1	10.75	9.38	5.00	6.62
	23210*	10	3230HV	2.3:1	10.75	9.38	5.00	6.62
8822-2		20	3230HV	2.5:1	10.41	9.03	4.51	7.00
	23220	20	3230HV	2.3:1	10.75	9.38	5.00	6.62
8822-2.75		20	4430V	2.5:1	10.41	9.03	4.83	7.00
	032481H	20	4430V	2.2:1	10.00	9.81	5.06	6.62
8821		15 to 20	4430V	3.0:1	12.00	9.03	4.84	7.00
	24420	15 to 20	4430V	2.7:1	12.50	10.13	5.37	6.62
8813		7-1/2 to 10	4430V	3.0:1	13.00	9.44	5.03	7.94
	24407	7-1/2	4430V	2.7:1	12.50	10.13	5.37	6.62
	24410	10	4430V	2.7:1	12.50	10.13	5.37	6.62
8823		15 to 20	4430V	3.0:1	13.00	9.44	5.03	7.94
	24420	15 to 20	4430V	2.7:1	12.50	10.13	5.37	6.62
8833		25 to 30	4430V	3.0:1	13.00	9.44	5.03	7.94
	24430	25 to 30	4430V	2.7:1	12.50	10.13	5.37	6.62

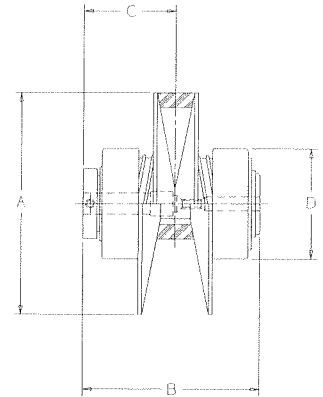

* Not an ideal interchange due to the difference in the belt width or angle. For best performance, you should consider replacing the entire drive.

¹ Requires sheave re-alignment.

SPEED SELECTOR

“Series 45”

Fixed Center Drives

DRIVER PULLEY MODEL NUMBER		DRIVEN PULLEY MODEL NUMBER		HP @ 1750 RPM (DRIVER)	BELT SIZE	DRIVEN SPEED RANGE (1750 RPM DRIVER)		“A” DRIVER O.D.	“B” DRIVEN O.D.	“C” OFFSET
SPEED SELECTOR	LOVEJOY	SPEED SELECTOR	LOVEJOY			MIN	MAX			
406		5116		1/2 to 1	1422V	506	3800	5.75	6.50	1.75
	M-14		1401	1/2 to 1	1422V	430	3300	6.00	7.00	1.59
	M-007		260	3/4	1422V	573	5342	6.00	6.00	0.00
407		5128		1-1/2 to 2	1922V	435	4250	7.125	8.00	2.00
	HM-3		31901	1 to 1-1/2	1922V	590	4850	8.25	8.25	2.21
	HM-3		31902	2	1922V	590	4850	8.25	8.25	2.21
	M-19		1902	1 to 2	1922V	403	4260	7.50	8.25	1.81
409		5151		3 to 5	2322V	444	3700	9.00	10.50	2.44
	M-23		2303	3	2322V	346	3700	9.50	11.00	1.40
	M-23		2305	5	2322V	346	3700	9.50	11.00	1.40
411		5112		7-1/2 to 10	3226V	495	3740	10.56	12.00	3.25
	HM-7*		32905	7-1/2	2926V	590	4000	10.00	10.00	1.89
	HM-30*		34407	10	4430V	640	3200	12.50	12.50	2.19
414		5122		15 to 20	3230HV	630	3300	10.62	12.00	2.90
	HM-30*		34410	15 to 20	4430V	640	3200	12.50	12.50	2.19
414		5133		25 to 30	3230HV	580	2775	10.62	13.00	3.34
	HM-30*		34420	25 to 30	4430V	640	3200	12.50	12.50	2.19

* Not an ideal interchange due to the difference in the belt width or angle. For best performance, you should consider replacing the entire drive.

These interchange suggestions are only to be used to replace a complete belt drive system. Do not attempt to replace just one part of the drive with a different manufacturer's pulley.

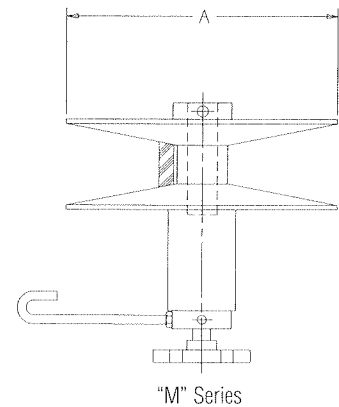

T.B. WOOD'S

“VPS” Series

Variable Speed Sheaves

MODEL NUMBER		BELT SIZE	P.D. RANGE		“A”	“B”
T.B. WOOD'S	LOVEJOY		MIN. P.D.	MAX. P.D.		
VPS-9-R		2530V	4.25	9.00	9.25	4.88
	LAS 25-10.25	2530V	5.00	9.95	10.25	5.38
VPS-10-R		2530V	5.25	10.00	10.25	4.88
	LAS 25-10.25	2530V	5.00	9.95	10.25	5.38
VPS-10-W		4430V	5.00	10.00	10.25	6.13
	LAS 44-10.75	4430V	4.84	10.35	10.75	7.38
VPS-129-W		4430V	4.30	12.90	13.00	7.00
	LAS 44-12.50	4430V	4.84	12.10	12.50	7.38

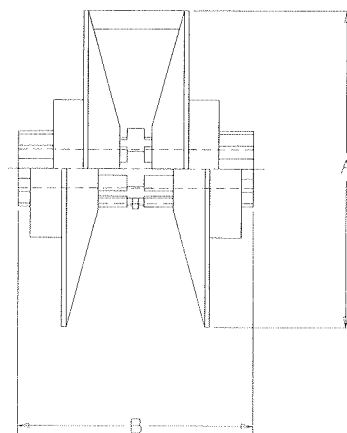

Variable Speed Pulley Interchange Guide



T.B. WOOD'S

"MCS" Series

2-Side Moveable

Spring Loaded Pulleys

MODEL NUMBER		HP @ 1750 RPM	BELT SIZE	RATIO	"A"	"B"	"C"	"D"
T.B. WOOD'S	LOVEJOY							
MCS-10W-HD	111979H-20	15	4430V	2.0:1	10.25	9.94	5.06	6.75
		15 to 20	4430V	2.1:1	10.75	10.12	5.34	6.63
MCS-12W-HD	24420	15 to 20	4430V	2.0:1	12.25	9.94	5.06	6.75
		15 to 20	4430V	2.7:1	12.50	10.12	5.38	6.63
MCS-11S	23230	25	3230HV	2.0:1	10.75	9.56	5.06	6.75
		25 to 30	3230HV	2.3:1	10.75	9.38	5.00	6.63
MCS-12S	112579H-30* 021881H-30*	25	3230HV	2.0:1	12.25	9.56	5.12	6.75
		25 to 30	3230HV	2.0:1	12.50	9.33	4.97	6.63
		25 to 30	3230HV	2.0:1	12.25	8.94	4.75	6.63
MCS-13S	05188H*	30	3230HV	2.0:1	13.00	9.56	5.12	6.75
		30	3230HV	2.0:1	13.00	9.56	5.12	6.63

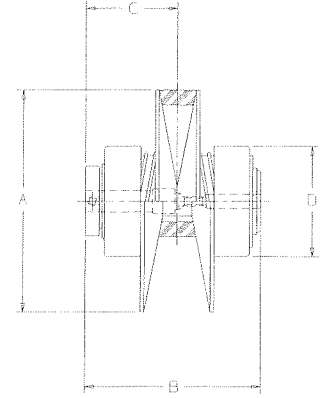

* These models are designed for **driven** applications only. For **driver** applications, please consult the factory.

T.B. WOOD'S

"PRO" Series

2-Side Moveable

Spring Loaded Pulleys

MODEL NUMBER		HP @ 1750 RPM	BELT SIZE	RATIO	"A"	"B"	"C"	"D"
T.B. WOOD'S	LOVEJOY							
160N		1 to 2	1922V	3.0:1	6.50	5.50	2.75	4.00
	21901	1-1/2	1922V	3.0:1	8.25	6.75	3.63	3.00
	21902	2	1922V	3.0:1	8.25	6.75	3.63	3.00
200N	21903	3 to 5	1922V	3.0:1	8.10	6.13	3.07	5.20
		3	1922V	3.0:1	8.25	6.75	3.63	3.00
240T	22907 22908	7-1/2 to 10	2926V	3.0:1	9.80	8.44	4.21	5.25
		7-1/2	2926V	3.0:1	10.00	8.25	4.31	6.63
		7-1/2 HD	2926V	3.0:1	10.00	8.25	4.31	6.63
250S	23220	15	3230HV	2.4:1	10.40	10.00	5.00	6.50
		15 to 20	3230HV	2.3:1	10.75	9.38	5.00	6.63
250W	24420 111979H-20	20	4430V	2.0:1	10.40	10.00	5.00	6.50
		15 to 20	4430V	2.7:1	12.50	10.12	5.38	6.63
		15 to 20	4430V	2.1:1	10.75	10.12	5.34	6.63
300W	24420	20	4430V	2.9:1	12.30	10.00	5.00	6.50
		15 to 20	4430V	2.7:1	12.50	10.12	5.38	6.63
320W	24430 072790H	30	4430V	3.0:1	13.00	10.50	5.25	6.50
		25 to 30	4430V	2.7:1	12.50	10.12	5.38	6.63
		25 to 30	4430V	2.8:1	13.00	10.13	5.38	6.63

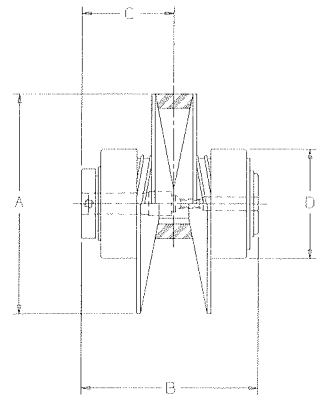

T.B. WOOD'S

"All-Pro" Series

2-Side Moveable

Spring Loaded Pulleys

MODEL NUMBER		HP @ 1750 RPM	BELT SIZE	RATIO	"A"	"B"	"C"	"D"
T.B. WOOD'S	LOVEJOY							
AP160M		1 to 1-1/2	1922V	3.0:1	6.50	5.50	2.75	4.00
	21901	1	1922V	3.0:1	8.25	6.75	3.63	3.00
	21902	2	1922V	3.0:1	8.25	6.75	3.63	3.00
AP200N		2 to 5	1922V	3.0:1	8.10	6.13	3.07	5.20
	21903	3	1922V	3.0:1	8.25	6.75	3.63	3.00
AP260T		5 to 10	2926V	3.0:1	10.50	7.48	3.74	5.40
	22905	5	2926V	3.0:1	10.00	8.25	4.31	6.63
	22907	7-1/2	2926V	3.0:1	10.00	8.25	4.31	6.63
	22908	8	2926V	3.0:1	10.00	8.25	4.31	6.63
AP260U*		5 to 10	3226V	2.4:1	10.50	7.48	3.74	5.40
	23207*		3230HV	2.3:1	10.75	9.38	5.00	6.63
	23210*		3230HV	2.3:1	10.75	9.38	5.00	6.63
AP255W		7-1/2 to 15	4430V	2.5:1	10.40	9.60	4.80	6.67
	24407	7-1/2	4430V	2.7:1	12.50	10.13	5.38	6.63
	24410	10	4430V	2.7:1	12.50	10.13	5.38	6.63
	24420	15 to 20	4430V	2.7:1	12.50	10.13	5.38	6.63
AP255S		10 to 20	3230HV	2.5:1	10.40	9.60	4.80	6.67
	23210	10	3230HV	2.3:1	10.75	9.38	5.00	6.63
	23210	20	3230HV	2.3:1	10.75	9.38	5.00	6.63
AP321W		7-1/2 to 10	4430V	3.0:1	13.00	9.60	4.80	6.67
	24407	7-1/2	4430V	2.7:1	12.50	10.13	5.38	6.63
	24410	10	4430V	2.7:1	12.50	10.13	5.38	6.63
AP322W		10 to 20	4430V	3.0:1	13.00	9.60	4.80	6.67
	24410	10	4430V	2.7:1	12.50	10.13	5.38	6.63
	24420	20	4430V	2.7:1	12.50	10.13	5.38	6.63
AP323W		15 to 30	4430V	3.0:1	13.00	9.60	4.80	6.67
	24420	25 to 30	4430V	2.7:1	12.50	10.13	5.38	6.63
	24430	25 to 30	4430V	2.7:1	12.50	10.13	5.38	6.63

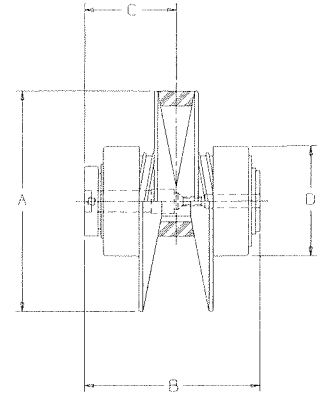

* Not an ideal interchange due to the difference in the belt width. For best performance, you should consider replacing the entire drive.

T.B. WOOD'S

"Roto-Cone" Series

2-Side Moveable

Spring Loaded Pulleys

MODEL NUMBER		HP @ 1750 RPM	BELT SIZE	RATIO	"A"	"B"	"C"	"D"
T.B. WOOD'S	LOVEJOY							
RC55		1/2	1422V	3.0:1	5.50	5.125	1.00	2.125
	245	1/2	1422V	3.0:1	6.00	4.86	1.31	2.25
RC60*		3/4	1922V	3.0:1	6.00	6.06	.94	2.125
	260*	3/4	1422V	3.0:1	6.00	4.86	1.31	2.25
RC75		1 to 1-1/2	1922V	3.0:1	7.50	7.50	1.25	2.50
	301E	1 to 1-1/2	1922V	3.0:1	7.50	7.13	1.56	2.50
RC80		3	2322V	3.0:1	8.00	8.50	1.44	3.00
	3030E	3	2322V	3.0:1	8.50	8.75	2.00	2.87
RC105		3	2926V	4.0:1	10.62	8.5	1.81	3.00
	403E	3	2926V	3.8:1	11.00	8.75	1.81	2.87
RC100		5	2926V	3.0:1	10.00	10.81	2.06	3.87
	3050E	5	2926V	3.0:1	10.00	10.31	2.13	3.19
RC1315		15	4430V	3.0:1	13.00	12.87	2.25	5.00
	3150B	15	4430V	3.0:1	13.00	13.44	2.50	4.00

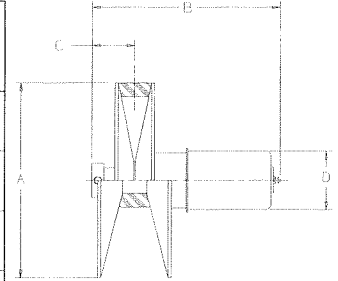

If any of the above Wood's model numbers contain a "W" suffix, it is a manually adjustable pulley. These are not directly interchangeable with Lovejoy. The entire drive will need to be replaced. Call Lovejoy Engineering for assistance.

* Not an ideal interchange due to the difference in the belt width. For best performance, you should consider replacing the entire drive.

Lovejoy Pulley Refurbishing Service

Variable Speed Pulleys are often exposed to harsh environments and tough operating conditions which can reduce the pulley's service life. Fortunately, Lovejoy's Variable Speed Pulley Refurbishing Service offers the opportunity to have your Lovejoy pulley inspected and evaluated for possible refurbishing and repair. Some pulleys may only need individual parts replaced in order to be brought back into service. Therefore, refurbishing is often less costly than replacement.

Additionally, pulley inspection can often spot potential problems in the drive setup and operation, such as worn or undersized shafts, belt misalignment and a variety of other problems. While Lovejoy can truly be your variable speed drive partner, it is important to remember that not all pulley repairs will be cost effective. Contact Lovejoy Customer Service for complete information on the Lovejoy Pulley Refurbishing Service.

Lovejoy's Variable Speed Pulley-Belt Drive Trouble-Shooting Guide

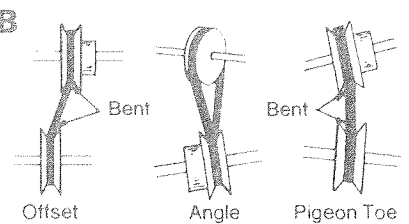
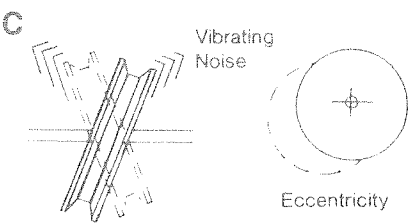
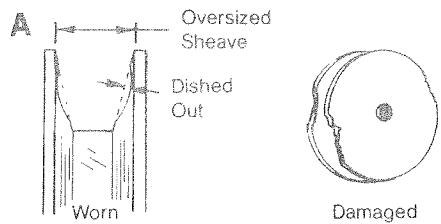
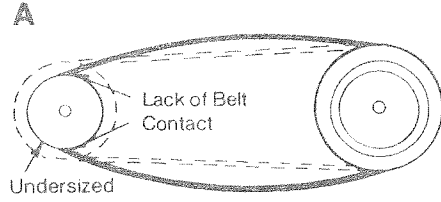
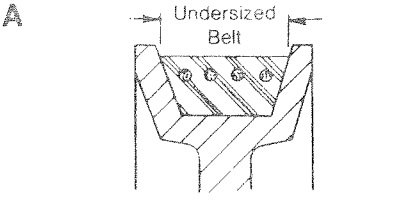
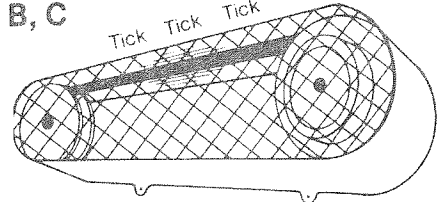
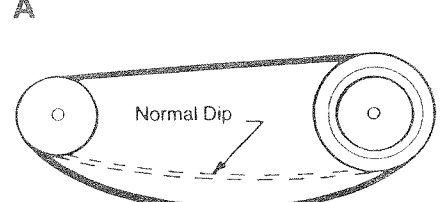
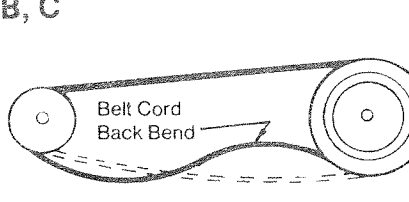
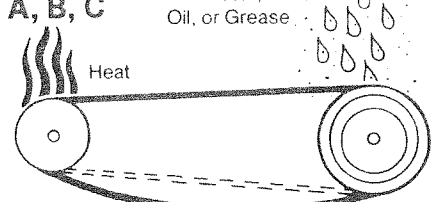
 <p>MISALIGNED SHEAVES</p>	 <p>SHEAVE WOBBLE</p>	 <p>SHEAVE PROBLEMS</p>
 <p>IMPROPER SHEAVE SIZE</p>	 <p>BELT BOTTOMING</p>	 <p>MECHANICAL INTERFERENCE</p>
 <p>OVERLOADED DRIVE</p>	 <p>EXCESSIVE BELT TENSION</p>	 <p>BELT HOP AND SLIP</p>

PROBLEM	PROBABLE CAUSE	SUGGESTED CORRECTION
<p>A BELT SLIPPAGE</p> <ul style="list-style-type: none"> • Rule of thumb very audible belt squeal = 5% or more belt slippage 	<ol style="list-style-type: none"> 1. Overloaded drive 2. Worn sheaves 3. Excessive dust, oil, or grease 4. Lack of flange support (weak VSP spring tension or broken spring) 5. Improper companion sheave size 6. Undersized P.D. (Belt Riding on bottom of sheave) 	<ul style="list-style-type: none"> • Check motor ampere load to max. speed range of pulley drive to insure proper size drive package selected. • Replace worn sheaves • Provide better shielding • Replace weak or broken spring; Consult factory; consult catalog for pulley rating • Consult catalog specifications and factory • 1/32" min. belt clearance when belt at pulley's specified minimum pitch diameter
<p>B RAPID BELT WEAR</p> <ul style="list-style-type: none"> • Heavy rubber dust deposit • Belt side "wear" pattern irregular • Heat build-up beyond 160°F max. limit 	<ol style="list-style-type: none"> 1. Misaligned sheaves 2. Loose motorbase supports 3. Damaged or worn sheaves 4. Excessive temperatures 5. Mechanical interference 6. Overloaded drive 7. Broken belt cords (excessive spring tension) 8. Dirt and grit entering drive 	<ul style="list-style-type: none"> • Realign sheaves — remove "bends" • Replace undersize screws or broken base • Replace sheaves • Ventilate belt guard — determine cause • Remove interference — move pulley over • Increase pitch diameter • Reduce pulley HP rating — reduce spring tension • Air ventilate belt guard
<p>C VIBRATION</p> <ul style="list-style-type: none"> • Pulley sheave lacks dynamic smoothness common to belt drive arrangement 	<ol style="list-style-type: none"> 1. Sheave wobble 2. Pulleys or sheaves out of balance 3. Mechanical interference 4. Pulsating loads belt hop and skip 5. Undersized motorshaft 6. Bent shaft 7. Worn — Undersize motorbase — Improper installation 8. Excessive pulley spring tension 	<ul style="list-style-type: none"> • Replaced distorted sheave rim; replace worn "QD" bushing • Determine cause, return to factory for correction • Enlarge belt guard, and avoid pulley housing contact • Belt's side surfaces glazed - replace; remove oil from pulley's flange surfaces • Correct or resize shaft diameter per NEMA specifications • Replace shaft • Replace, consult catalog for HP rating • Install lighter HP rated pulley consult factory.