



**N.B.** For the correct choice of the gearmotor, please refer to the tables on page 118. Refer to **AM** series page 12 for motor revs under load. On request, motor may be supplied with electromagnetic brake at 230 Vac, marked with the letter KA (ACKA), or at 24 Vdc, marked with the letter KB (ACKB), see specifications on page 120.

**N.B.** Para una selección correcta del motorreductor se aconseja ajustarse a las tablas presentadas en la página 118. Para las revoluciones del motor bajo carga, hágase referencia a la serie **AM** en la pág. 12. A petición es posible suministrar el motor con freno electromagnético alimentado con 230 Vca, que se distingue por la letra KA (ACKA), ó con 24 Vdc, que se distingue por las letras KB (ACKB), ver características en la pág. 120.

## COAXIAL GEARED MOTOR WITH GEAR PAIRS

**MOTOR:** Asynchronous single or three phase with 2 or 4 poles, totally enclosed with external ventilation. Thermal safety cutout on single phase models. Class F winding. IP65 protection according to CEI EN 60529.

**GEAR UNIT:** With die-cast aluminum housing. Case-hardened gearing with shafts rotating on roller bearings. Lubricated with synthetic oil. High temperature oil seals. 15 gear ratios (i), from 7.4 to 441.9. Rated torque 44.3 in-lbs. Version B3 or B5.

## MOTORREDUCTOR COAXIAL DE ENGRANAJES

**MOTOR:** *asíncrono monofásico o trifásico de 2 ó 4 polos, en forma cerrada con ventilación externa. Protector térmico de seguridad en el tipo monofásico. Aislamiento clase F. Protección IP 65 según normas CEI EN 60529.*

**REDUCTOR:** *con carcasa de aluminio inyectado a presión. Engranajes templados y endurecidos con correspondientes ejes que giran sobre cojinetes de rodillos. Lubricación con aceite especial de larga duración. Retenes para la estanqueidad de goma especial para altas temperaturas. Las relaciones de reducción disponibles (i) son 15, de 7.4 a 441.9. Par nominal 44.3 in-lbs. Versión B3 ó B5.*

# AC



Type Tipo	Ratio Relación	Delivered power Potencia entregada	Input r.p.m. no-load Revoluciones entrada sin carga	Output r.p.m. no-load Revoluciones salida sin carga	Rated torque Par nominal	Voltage Tensión	Current Intensidad	Capacitor Condensador
	i	HP	rpm	rpm	in-lbs	Vac - 60 Hz	A	µF
AC 66	7.4	1/23	3360	453.6	5.3	115 1Ø	0.82	10
AC 100P	7.4	1/18	3360	453.6	7.1	115 1Ø	0.98	12.5
AC 160P2	7.4	1/10	3360	453.6	12.4	115 1Ø	1.30	16
AC 44	7.4	1/56	1680	223.2	4.4	115 1Ø	0.62	12.5
AC 80P	7.4	1/40	1680	223.2	6.2	115 1Ø	0.80	16
AC 110P2	7.4	1/33	1680	223.2	8	115 1Ø	1	20
AC 72T	7.4	1/33	3360	453.6	3.5	230 3Ø	0.26	-
AC 244PT	7.4	1/13	3360	453.6	9.7	230 3Ø	0.62	-
AC 320 P2T	7.4	1/9	3360	453.6	15	230 3Ø	0.74	-
AC 66T	7.4	1/56	1680	223.2	4.4	230 3Ø	0.23	-
AC 110PT	7.4	1/40	1680	223.2	6.2	230 3Ø	0.30	-
AC 145P2T	7.4	1/33	1680	223.2	7.1	230 3Ø	0.38	-
AC 66	10.17	1/23	3360	330	7.1	115 1Ø	0.82	10
AC 100P	10.17	1/18	3360	330	9.7	115 1Ø	0.98	12.5
AC 160P2	10.17	1/10	3360	330	16.8	115 1Ø	1.30	16
AC 44	10.17	1/56	1680	165	6.2	115 1Ø	0.62	12.5
AC 80P	10.17	1/40	1680	165	8.9	115 1Ø	0.80	16
AC 110P2	10.17	1/33	1680	165	11.5	115 1Ø	1	20
AC 72T	10.17	1/33	3360	330	5.3	230 3Ø	0.26	-
AC 244PT	10.17	1/13	3360	330	13.3	230 3Ø	0.62	-
AC 320P2T	10.17	1/9	3360	330	20.4	230 3Ø	0.74	-
AC 66T	10.17	1/56	1680	165	6.2	230 3Ø	0.23	-
AC 110PT	10.17	1/40	1680	165	8	230 3Ø	0.30	-
AC 145P2T	10.17	1/33	1680	165	10.6	230 3Ø	0.38	-
AC 66	13.32	1/23	3360	252	9.7	115 1Ø	0.82	10
AC 100P	13.32	1/18	3360	252	12.3	115 1Ø	0.98	12.5
AC 160P2	13.32	1/10	3360	252	22.1	115 1Ø	1.30	16
AC 44	13.32	1/56	1680	126	8.9	115 1Ø	0.62	12.5
AC 80P	13.32	1/40	1680	126	11.5	115 1Ø	0.80	16
AC 110P2	13.32	1/33	1680	126	15	115 1Ø	1	20
AC 72T	13.32	1/33	3360	252	7.1	230 3Ø	0.26	-
AC 244PT	13.32	1/13	3360	252	17.7	230 3Ø	0.62	-
AC 320P2T	13.32	1/9	3360	252	27.4	230 3Ø	0.74	-
AC 66T	13.32	1/56	1680	126	8	230 3Ø	0.23	-
AC 110PT	13.32	1/40	1680	126	10.6	230 3Ø	0.30	-
AC 145P2T	13.32	1/33	1680	126	14.2	230 3Ø	0.38	-
AC 66	17.76	1/23	3360	188.4	13.3	115 1Ø	0.82	10
AC 100P	17.76	1/18	3360	188.4	17.7	115 1Ø	0.98	12.5
AC 160P2	17.76	1/10	3360	188.4	29.2	115 1Ø	1.30	16
AC 44	17.76	1/56	1680	94.2	11.5	115 1Ø	0.62	12.5
AC 80P	17.76	1/40	1680	94.2	15.9	115 1Ø	0.80	16
AC 110P2	17.76	1/33	1680	94.2	19.5	115 1Ø	1	20
AC 72T	17.76	1/33	3360	188.4	8.9	230 3Ø	0.26	-
AC 244PT	17.76	1/13	3360	188.4	23.9	230 3Ø	0.62	-
AC 320P2T	17.76	1/9	3360	188.4	36.3	230 3Ø	0.74	-
AC 66T	17.76	1/56	1680	94.2	10.6	230 3Ø	0.23	-
AC 110PT	17.76	1/40	1680	94.2	14.2	230 3Ø	0.30	-
AC 145P2T	17.76	1/33	1680	94.2	18.6	230 3Ø	0.38	-



# AC

Type Tipo	Ratio Relación	Delivered power Potencia entregada	Input r.p.m. no-load Revoluciones entrada sin carga	Output r.p.m. no-load Revoluciones salida sin carga	Rated torque Par nominal	Voltage Tensión	Current Intensidad	Capacitor Condensador
	i	HP	rpm	rpm	in-lbs	Vac - 60 Hz	A	µF
AC 66	24.4	1/23	3360	136.8	18.6	115 1Ø	0.82	10
AC 100P	24.4	1/18	3360	136.8	23.9	115 1Ø	0.98	12.5
AC 160P2	24.4	1/10	3360	136.8	40.7	115 1Ø	1.30	16
AC 44	24.4	1/56	1680	68.4	15.9	115 1Ø	0.62	12.5
AC 80P	24.4	1/40	1680	68.4	22.1	115 1Ø	0.80	16
AC 110P2	24.4	1/33	1680	68.4	27.4	115 1Ø	1	20
AC 72T	24.4	1/33	3360	136.8	12.3	230 3Ø	0.26	-
AC 244PT	24.4	1/13	3360	136.8	32.7	230 3Ø	0.62	-
AC 320P2T	24.4	1/9	3360	136.8	44.3	230 3Ø	0.74	-
AC 66T	24.4	1/56	1680	68.4	14.2	230 3Ø	0.23	-
AC 110PT	24.4	1/40	1680	68.4	20.4	230 3Ø	0.30	-
AC 145P2T	24.4	1/33	1680	68.4	25.7	230 3Ø	0.38	-
AC 66	31.9	1/23	3360	104.4	23.9	115 1Ø	0.82	10
AC 100P	31.9	1/18	3360	104.4	31	115 1Ø	0.98	12.5
AC 160P2	31.9	1/10	3360	104.4	44.3	115 1Ø	1.30	16
AC 44	31.9	1/56	1680	52.2	21.2	115 1Ø	0.62	12.5
AC 80P	31.9	1/40	1680	52.2	28.3	115 1Ø	0.80	16
AC 110P2	31.9	1/33	1680	52.2	36.3	115 1Ø	1	20
AC 72T	31.9	1/33	3360	104.4	16.8	230 3Ø	0.26	-
AC 244PT	31.9	1/13	3360	104.4	43.4	230 3Ø	0.62	-
AC 66T	31.9	1/56	1680	52.2	18.6	230 3Ø	0.23	-
AC 110PT	31.9	1/40	1680	52.2	26.6	230 3Ø	0.30	-
AC 145P2T	31.9	1/33	1680	52.2	33.6	230 3Ø	0.38	-
AC 66	42.6	1/23	3360	78	31.9	115 1Ø	0.82	10
AC 100P	42.6	1/18	3360	78	41.6	115 1Ø	0.98	12.5
AC 44	42.6	1/56	1680	39	28.3	115 1Ø	0.62	12.5
AC 80P	42.6	1/40	1680	39	38	115 1Ø	0.80	16
AC 72T	42.6	1/33	3360	78	22.1	230 3Ø	0.26	-
AC 244PT	42.6	1/13	3360	78	*44.3	230 3Ø	0.62	-
AC 66T	42.6	1/56	1680	39	25.7	230 3Ø	0.23	-
AC 110PT	42.6	1/40	1680	39	35.4	230 3Ø	0.30	-
AC 145P2T	42.6	1/33	1680	39	*44.3	230 3Ø	0.38	-
AC 66	58.6	1/23	3360	56.4	*44.3	115 1Ø	0.80	10
AC 44	58.6	1/56	1680	28.2	39.8	115 1Ø	0.62	12.5
AC 72T	58.6	1/33	3360	56.4	31	230 3Ø	0.26	-
AC 66T	58.6	1/56	1680	28.2	35.4	230 3Ø	0.23	-
AC 66	76.7	1/23	3360	43.2	*44.3	115 1Ø	0.80	10
AC 44	76.7	1/56	1680	21.6	*44.3	115 1Ø	0.62	12.5
AC 72T	76.7	1/33	3360	43.2	40.7	230 3Ø	0.26	-
AC 66T	76.7	1/56	1680	21.6	*44.3	230 3Ø	0.23	-
AC 66	102.3	1/23	3360	32.4	*44.3	115 1Ø	0.80	10
AC 44	102.3	1/56	1680	16.2	*44.3	115 1Ø	0.62	12.5
AC 72T	102.3	1/33	3360	32.4	*44.3	230 3Ø	0.26	-
AC 66T	102.3	1/56	1680	16.2	*44.3	230 3Ø	0.23	-
AC 40	140.6	1/33	3360	23.9	*44.3	115 1Ø	0.62	8
AC 44	140.6	1/56	1680	11.9	*44.3	115 1Ø	0.62	12.5
AC 72T	140.6	1/33	3360	23.9	*44.3	230 3Ø	0.26	-
AC 66T	140.6	1/56	1680	11.9	*44.3	230 3Ø	0.23	-



Type Tipo	Ratio Relación	Delivered power Potencia entregada	Input r.p.m. no-load Revoluciones entrada sin carga	Output r.p.m. no-load Revoluciones salida sin carga	Rated torque Par nominal	Voltage Tensión	Current Intensidad	Capacitor Condensador
	i	HP	rpm	rpm	in-lbs	Vac - 60 Hz	A	µF
AC 40	184	1/33	3360	18	*44.3	115 1Ø	0.62	8
AC 44	184	1/56	1680	9	*44.3	115 1Ø	0.62	12.5
AC 72T	184	1/33	3360	18	*44.3	230 3Ø	0.26	-
AC 66T	184	1/56	1680	9	*44.3	230 3Ø	0.23	-
AC 40	245.5	1/33	3360	13.7	*44.3	115 1Ø	0.62	8
AC 44	245.5	1/56	1680	6.9	*44.3	115 1Ø	0.62	12.5
AC 72T	245.5	1/33	3360	13.7	*44.3	230 3Ø	0.26	-
AC 66T	245.5	1/56	1680	6.9	*44.3	230 3Ø	0.23	-
AC 40	337.5	1/33	3360	9.8	*44.3	115 1Ø	0.62	8
AC 44	337.5	1/56	1680	4.9	*44.3	115 1Ø	0.62	12.5
AC 72T	337.5	1/33	3360	9.8	*44.3	230 3Ø	0.26	-
AC 66T	337.5	1/56	1680	4.9	*44.3	230 3Ø	0.23	-
AC 40	441.9	1/33	3360	7.6	*44.3	115 1Ø	0.62	8
AC 44	441.9	1/56	1680	3.8	*44.3	115 1Ø	0.62	12.5
AC 72T	441.9	1/33	3360	7.6	*44.3	230 3Ø	0.26	-
AC 66T	441.9	1/56	1680	3.8	*44.3	230 3Ø	0.23	-

(\*) - Under no circumstances should the torque values marked with an asterisk be exceeded. With higher gear ratios the motor power is considerably higher than the capacity of the gear unit.

(\*) - Los valores referentes al par marcados con el asterisco, no se deben en absoluto superar, ya que, con las altas relaciones, la potencia del motor es notablemente mayor que la capacidad del reductor.

Also available in 230 Vac single phase input.

Also available in 460 Vac three phase input.

Note - 230 Vac three phase suitable at 208 Vac.

Disponible también con entrada monofásica de 230 Vca.

Disponible también con entrada trifásica de 460 Vca.

Nota - 230 Vca trifásica adecuada para 208 Vca.



# AC

## B3

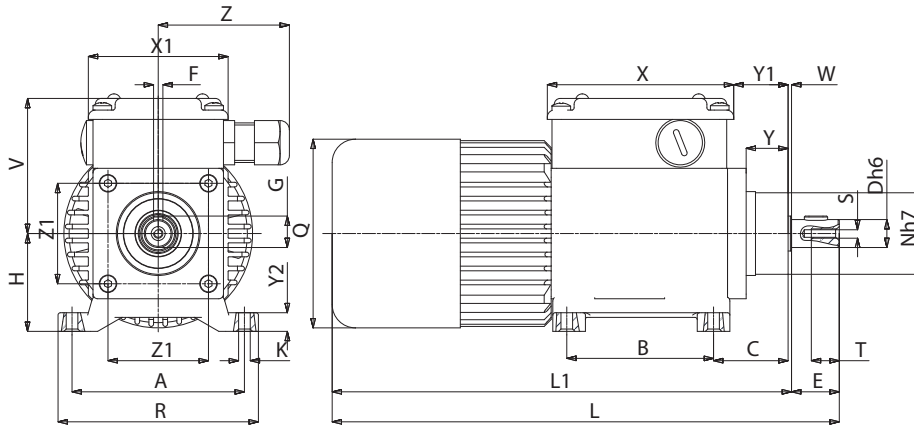

Type Tipo	A	B	C	D	E	F	G	H	K	L	L1	N	Q
AC...	2.913	2.480	1.319	0.472	0.807	0.157	0.535	1.693	0.217	8.425	7.638	1.417	3.189
AC...P	2.913	2.480	1.319	0.472	0.807	0.157	0.535	1.693	0.217	9.016	8.228	1.417	3.189
AC...P2	2.913	2.480	1.319	0.472	0.807	0.157	0.535	1.693	0.217	9.803	9.016	1.417	3.189

Type Tipo	R	S	T	V	X	X1	Y	Y1	Y2	W	Z	Z1	Weight Peso lbs
AC...	3.386	M4	0.394	2.362	3.150	2.362	0.689	0.984	0.315	0.079	2.205	1.693	4.338
AC...P	3.386	M4	0.394	2.362	3.150	2.362	0.689	0.984	0.315	0.079	2.205	1.693	4.923
AC...P2	3.386	M4	0.394	2.362	3.150	2.362	0.689	0.984	0.315	0.079	2.205	1.693	5.828

## B5

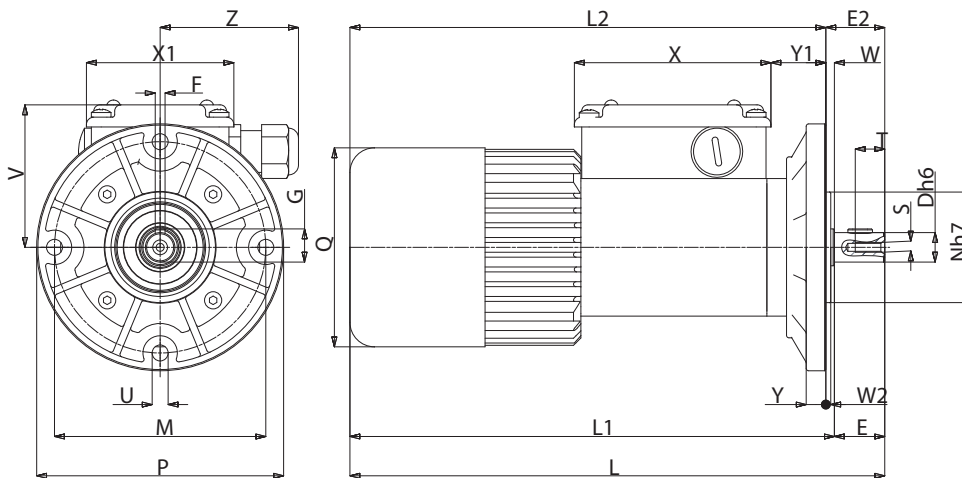

Type Tipo	D	E	E2	F	G	L	L1	L2	M	N	P	Q
AC...	0.472	0.807	0.945	0.157	0.535	8.425	7.638	7.480	3.386	1.772	3.937	3.189
AC...P	0.472	0.807	0.945	0.157	0.535	9.016	8.228	8.070	3.386	1.772	3.937	3.189
AC...P2	0.472	0.807	0.945	0.157	0.535	9.803	9.016	8.858	3.386	1.772	3.937	3.189

Type Tipo	S	T	U	V	X	X1	Y	Y1	W	W2	Z	Weight Peso lbs
AC...	M4	0.394	0.256	2.362	3.150	2.362	0.315	0.906	0.138	0.079	2.205	4.426
AC...P	M4	0.394	0.256	2.362	3.150	2.362	0.315	0.906	0.138	0.079	2.205	5.011
AC...P2	M4	0.394	0.256	2.362	3.150	2.362	0.315	0.906	0.138	0.079	2.205	5.916

For the self-braking version, add the letter KA or KB to the type designation. Dimensions L, L1, increase by 1.063 in.

En la versión freno, añadir las letras KA ó KB a la sigla del tipo. Las cotas L, L1, Y1 aumentan de 1.063 in.