

N.B. For the correct choice of the gearmotor, please refer to the tables on page 118. On request, motor can be supplied with electromagnetic brake at 24 Vdc, marked with letter KB (ACCEKB), see specifications on page 120.

N.B. Para una selección correcta del motorreductor se aconseja ajustarse a las tablas presentadas en la página 118. A petición es posible suministrar el motor con freno electromagnético alimentado con 24 Vdc, que se distingue por las letras KB (ACCEKB), ver características en la pág. 120.

COAXIAL GEARED MOTOR WITH PLANETARY REDUCTION GEAR

MOTOR: Direct Current with permanent magnets. Totally enclosed with external ventilation. Class F winding. 12 or 24 Vdc power supply. Absorbed power 60 W. IP65 protection according to CEI EN 60529.

GEAR UNIT: First stage with die-cast aluminum housing, second stage steel. Case-hardened gearing with shafts rotating on roller bearings. Lubricated with synthetic. High temperature oil seals. 15 gear ratios (i) from 37 to 2209.5. Rated torque 208 in-lbs. Version B3 or B5.

MOTORREDUCTOR COAXIAL DE ENGRANAJES CON REDUCTOR EPICICLOIDAL

MOTOR: de corriente continua con imanes permanentes, en forma cerrada con ventilación externa. Aislamiento clase F. Alimentación con 12 ó 24 Vcc. Potencia absorbida 60 W. Protección IP 65 según normas CEI EN 60529.

REDUCTOR: Primera etapa con carcasa de aluminio inyectado a presión, segunda etapa de acero. Engranajes templados y endurecidos con correspondientes ejes que giran sobre cojinetes de rodillos. Lubricación con aceite especial de larga duración. Retenes para la estanqueidad de goma especial para altas temperaturas. Las relaciones de reducción disponibles (i) son 15, de 37 a 2209.5. Par nominal 208 in-lbs. Versión B3 ó B5.



ACCE

Type	Ratio	Voltage	Current	Absorbed power	Delivered power	Input r.p.m.	Output r.p.m.	Rated torque
Tipo	Relación	Tensión	Intensidad	Potencia absorbida	Potencia entregada	Revoluciones entrada	Revoluciones salida	Par nominal
	i	V	A	W	HP	rpm	rpm	in-lbs
ACCE 12MP	37	12	5	60	1/20	2800	75	38.1
ACCE 24MP	37	24	2.5	60	1/20	2800	75	38.1
ACCE 12MP	50.8	12	5	60	1/20	2800	55	54.9
ACCE 24MP	50.8	24	2.5	60	1/20	2800	55	54.9
ACCE 12MP	66.6	12	5	60	1/20	2800	42	67.3
ACCE 24MP	66.6	24	2.5	60	1/20	2800	42	67.3
ACCE 12MP	88.8	12	5	60	1/20	2800	31.5	88.5
ACCE 24MP	88.8	24	2.5	60	1/20	2800	31.5	88.5
ACCE 12MP	122.1	12	5	60	1/20	2800	23	122.1
ACCE 24MP	122.1	24	2.5	60	1/20	2800	23	122.1
ACCE 12MP	159.8	12	5	60	1/20	2800	17.5	159.3
ACCE 24MP	159.8	24	2.5	60	1/20	2800	17.5	159.3
ACCE 12MP	213	12	5	60	1/20	2800	13	208.0
ACCE 24MP	213	24	2.5	60	1/20	2800	13	208.0
ACCE 12MP	293	12	4	48	1/26	3000	10.2	208.0
ACCE 24MP	293	24	2	48	1/26	3000	10.2	208.0
ACCE 12MP	383.6	12	3.4	41	1/31	3150	8.2	208.0
ACCE 24MP	383.6	24	1.7	41	1/31	3150	8.2	208.0
ACCE 12MP	511.4	12	2.8	34	1/40	3250	6.4	208.0
ACCE 24MP	511.4	24	1.4	34	1/40	3250	6.4	208.0
ACCE 12MP	703	12	2.2	26	1/62	3350	4.8	208.0
ACCE 24MP	703	24	1.1	26	1/62	3350	4.8	208.0
ACCE 12MP	920.5	12	2	24	1/83	3400	3.6	208.0
ACCE 24MP	920.5	24	1	24	1/83	3400	3.6	208.0
ACCE 12MP	1227.5	12	1.8	22	1/107	3450	2.8	208.0
ACCE 24MP	1227.5	24	0.9	22	1/107	3450	2.8	208.0
ACCE 12MP	1687.5	12	1.6	19	1/150	3500	2	208.0
ACCE 24MP	1687.5	24	0.8	19	1/150	3500	2	208.0
ACCE 12MP	2209.5	12	1.4	17	1/200	3550	1.6	208.0
ACCE 24MP	2209.5	24	0.7	17	1/200	3550	1.6	208.0

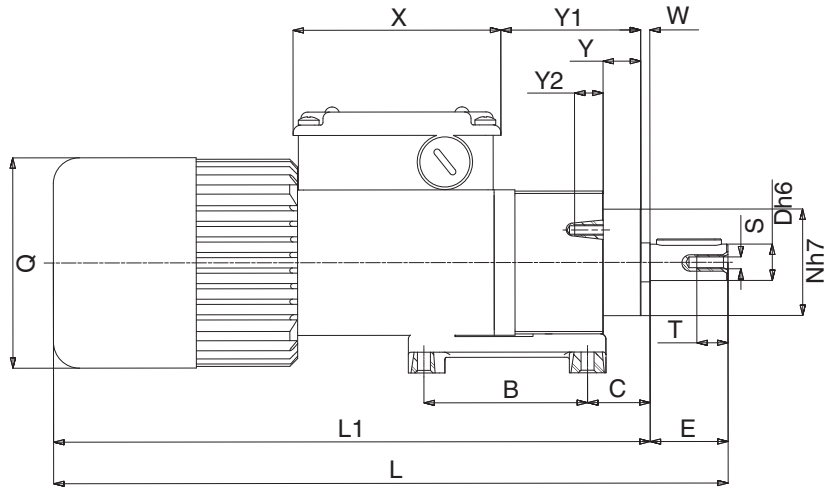
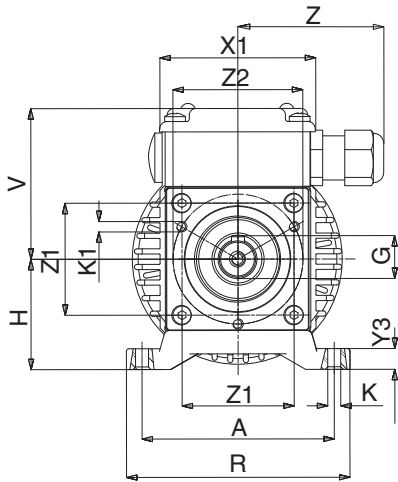

B3

Type Tipo	A	B	C	D	E	F	G	H	K	K1	L	L1	N	Q	R
ACCE 12/24 MP	2.913	2.480	0.945	0.551	1.181	0.197	0.630	1.693	0.216	M4	10.315	9.134	1.614	3.189	3.386

Type Tipo	S	T	V	X	X1	Y	Y1	Y2	Y3	W	Z	Z1	Z2	Weight Peso lbs
ACCE 12/24 MP	M5	0.394	2.362	3.150	2.362	0.571	2.185	0.433	0.315	0.138	2.205	1.693	1.969	5.486

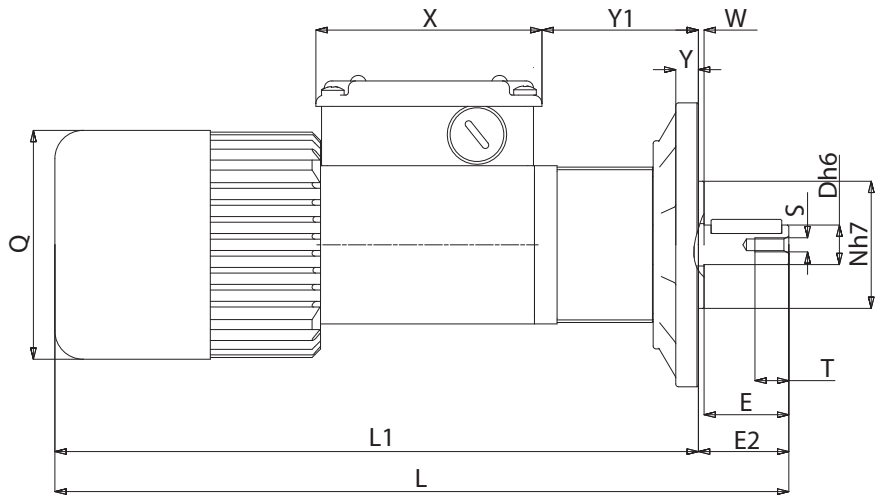
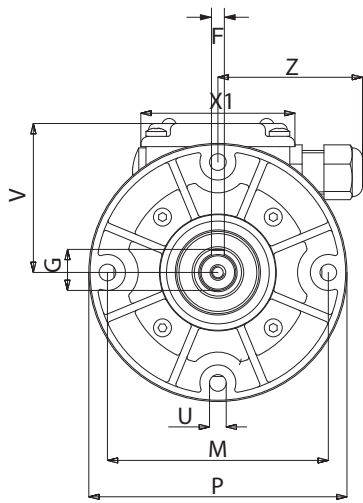

B5

Type Tipo	D	E	E2	F	G	L	L1	M	N	P	Q
ACCE 12/24 MP	0.551	1.181	1.260	0.197	0.630	10.315	9.056	3.386	1.772	3.937	3.189

Type Tipo	S	T	U	V	X	X1	Y	Y1	W	Z	Weight Peso lbs
ACCE 12/24 MP	M5	0.394	0.256	2.362	3.150	2.362	0.315	2.244	0.079	2.205	5.552

For the self-braking version, add the letter KA or KB to the type designation. Dimensions L, L1 increase by 1.063 in.

En la versión freno, añadir las letras KA ó KB a la sigla del tipo. Las cotas L, L1 aumentan de 1.063 in.