



BRUSHLESS SERVOMOTOR

4 poles sinusoidal brushless servomotor. totally enclosed. Rotor with NdFeB magnets. Safety circuit breaker. Winding class F. IP65 protection according to CEI EN 60529 standards. Feedback with 2 pole resolver.

Reduced clearance bearings with special grease for high temperatures.

Available in the RC version with circular connectors or RP version with cable clamps and pre-wired cables inside the motor.

On request a 24 Vdc NC brake (normally closed) with permanent magnets may be supplied. It is identified by the letter K (BSK). See specifications on page 120.

MOTORES SIN ESCOBILLAS

Sinusoidales de 4 polos. en forma cerrada. Rotor con imanes NdFeB. Protector térmico de seguridad. Aislamiento clase F. Protección IP65 según normas CEI EN 60529. Realimentación con resolver 2 polos. Cojinetes con juego reducido. con grasa especial para altas temperaturas.

Disponible en las versiones RC con conectores circulares o RP con prensaestopas y cables precableados dentro del motor.

A petición es posible montar un freno de 24 Vdc NC (normalmente cerrado) de imanes permanentes que se distingue por la letra K (BSK). Ver características en la pag. 120.



BS

Type - Tipo	U.m.	BS 35/30	BS 35/60	BS 45/35	BS 45/70	BS 55/50	BS 55/100	BS 80/50	BS 80/100
AC Drive voltage	Vac.	230	230	230	230	230	230	230	230
<i>Tensión CA accionamiento</i>									
Rated speed	Rpm	4000	4000	4000	4000	4000	4000	4000	4000
<i>Velocidad nominal</i>									
Torque with rotor blocked. flanged DT = 194°F *	in-lbs	0.752	1.460	1.770	3.009	4.425	7.965	10.62	20.35
<i>Par con rotor bloqueado con brida DT = 194°F *</i>									
Current at rated speed. flanged DT = 194°F *	A rms	0.22	0.40	0.51	0.75	1.00	1.77	2.66	4.9
<i>Corriente con rotor bloqueado con brida DT = 194°F *</i>									
Torque at rated speed. flanged DT = 194°F *	in-lbs	0.664	1.363	1.593	2.832	3.982	6.195	9.735	18.58
<i>Par a la velocidad nominal con brida DT = 194°F *</i>									
Current at rated speed. flanged DT = 194°F *	A rms	0.22	0.39	0.51	0.71	0.94	1.65	2.62	4.7
<i>Corriente a la velocidad nominal con brida DT = 194°F *</i>									
Rated power flanged DT = 194°F *	hp	1/23	1/12	1/10	1/5.5	1/4	1/2.5	1/1.6	1.2
<i>Potencia nominal con brida DT = 194°F *</i>									
Torque with rotor blocked in air DT = 194°F	in-lbs	0.575	1.106	1.283	2.257	3.363	6.018	8.850	16.37
<i>Par con rotor bloqueado al aire DT = 194°F</i>									
Current with rotor blocked in air DT = 194°F	A rms	0.17	0.30	0.36	0.60	0.76	1.37	2.2	3.83
<i>Corriente con rotor bloqueado al aire DT = 194°F</i>									



Type - Tipo	U.m.	BS 35/30	BS 35/60	BS 45/35	BS 45/70	BS 55/50	BS 55/100	BS 80/50	BS 80/100
Torque at rated speed in air DT = 194° F	in lbs	0.504	0.974	1.062	2.124	2.832	3.894	7.965	14.16
<i>Par a la velocidad nominal al aire DT = 194°F</i>									
Current at rated speed in air DT = 194° F	A rms	0.17	0.30	0.36	0.54	0.68	1.14	2.15	3.6
<i>Corriente a la velocidad nominal al aire DT = 194°F</i>									
Rated power in air DT = 194° F	hp	1/31	1/16	1/15	1/7.3	1/5.5	1/4	1/2	1/1.1
<i>Potencia nominal al aire DT = 194°F</i>									
Maximum torque	in lbs	2.213	4.425	5.310	9.027	13.28	23.90	31.86	61.07
<i>Par máximo</i>									
Maximum current	A rms	0.65	1.19	1.53	2.25	3.00	5.31	8	14.7
<i>Corriente máxima</i>									
Phase voltage constant	V x s	0.155	0.162	0.145	0.174	0.202	0.189	0.167	0.176
<i>Constante de tensión de fase</i>									
Torque constant	in-lbs/A	3.443	3.690	3.469	4.009	4.425	4.496	3.991	4.160
<i>Constante de par</i>									
Phase resistance at 68° F	Ohm	156	58	41	22	13	5	2.77	1.39
<i>Resistencia de fase a 68°F</i>									
Phase inductance	mH	207	103	74	43	33	14	6	2.75
<i>Inductancia de fase</i>									



BS

Type - Tipo	U.m.	BS 35/30	BS 35/60	BS 45/35	BS 45/70	BS 55/50	BS 55/100	BS 80/50	BS 80/100
Rotor inertia	lb in ²	0.01346	0.0201	0.02361	0.03964	0.07319	0.13535	0.2426	0.4647
<i>Inercia rotor</i>									
Working temperature	°F	32-104	32-104	32-104	32-104	32-104	32-104	32-104	32-104
<i>Temperatura operativa</i>									
Thermal cutout switch	/	PTC 284°F	PTC 284°F	Contatto NC	Contatto NC	Contatto NC	Contatto NC	Contatto NC	Contatto NC
<i>Térmico</i>				284°F	284°F	284°F	284°F	284°F	284°F

*Flanged on a steel plate. 11.81 x 11.81 x 0.787 in

*Con brida sobre placa de acero dimensiones 11.81 x 11.81 x 0.787 in

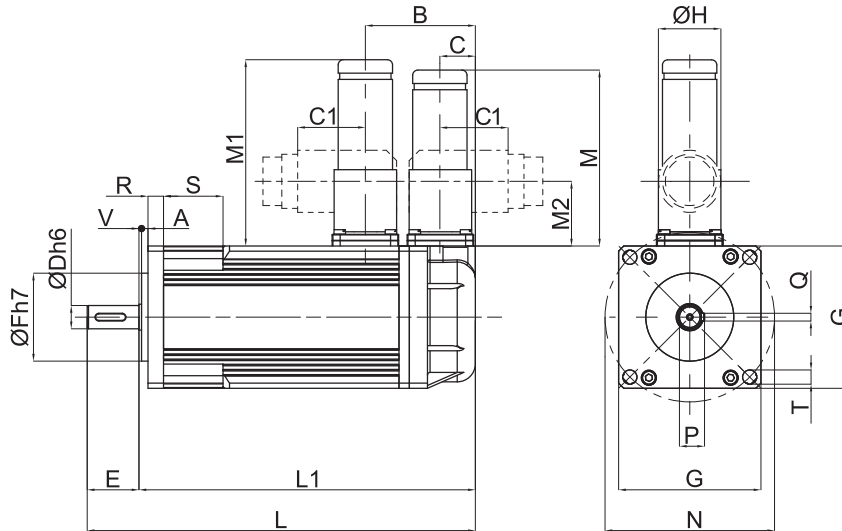

RC

Resolver - connector
 Resolver - conector

BS... RC

Type Tipo	A	B	C	C1	D	E	F	G	H	L	L1
BS 35/30 RC	0.059	1.437	0.472	1.063	0.197	0.590	0.866	1.378	0.827	4.803	4.213
BS 35/60 RC	0.059	1.437	0.472	1.063	0.197	0.590	0.866	1.378	0.827	5.984	5.394
BS 45/35 RC	0.079	1.850	0.492	1.063	0.236	0.807	0.984	1.771	0.827	5.472	4.665
BS 45/70 RC	0.079	1.850	0.492	1.063	0.236	0.807	0.984	1.771	0.827	6.850	6.043
BS 55/50 RC	0.098	1.673	0.492	1.063	0.354	0.768	1.339	2.165	0.827	5.905	5.138
BS 55/100 RC	0.098	1.673	0.492	1.063	0.354	0.768	1.339	2.165	0.827	7.874	7.106
BS 80/50 RC	0.118	1.673	0.492	0.866	0.55	1.181	1.771	3.150	0.984	6.811	5.630
BS 80/100 RC	0.118	1.673	0.492	0.866	0.55	1.181	1.771	3.150	0.984	8.780	7.598

Type Tipo	M	M1	M2	N	P	Q	R	S	T	V	Weight Peso lbs
BS 35/30 RC	2.677	2.835	0.984	1.673	-	-	0.157	0.591	0.138	0.020	1.102
BS 35/60 RC	2.677	2.835	0.984	1.673	-	-	0.157	0.591	0.138	0.020	1.588
BS 45/35 RC	2.835	2.835	0.984	2.087	-	-	0.197	0.787	0.169	0.020	1.676
BS 45/70 RC	2.835	2.835	0.984	2.087	-	-	0.197	0.787	0.169	0.020	3.881
BS 55/50 RC	2.835	2.835	0.984	2.579	0.409	0.118	0.236	0.906	0.216	0.039	2.889
BS 55/100 RC	2.835	2.835	0.984	2.579	0.409	0.118	0.236	0.906	0.216	0.039	4.867
BS 80/50 RC	3.346	2.677	0.709	3.858	0.630	0.197	0.315	1.181	0.256	0.079	5.733
BS 80/100 RC	3.346	2.677	0.709	3.858	0.630	0.197	0.315	1.181	0.256	0.079	9.040

Prewired resolver and power cables with lengths of 98.4/196.85/393.7 in are available on request

For the self-braking version add the letter K to the model code. Measurements L, L1 increase by: 0.945 in (BS35), 1.102 in (BS45), 1.142 in (BS55), 1.535 (BS80).

Resolver y cables de potencia precableados de 98.4/196.85/393.7 in de longitud están disponibles a petición

En la versión freno, añadir la letra K a la sigla del tipo. Las cotas L, L1 aumentan de: 0.945 in (BS35), 1.102 in (BS45), 1.142 in (BS55), 1.535 in (BS80).



BS

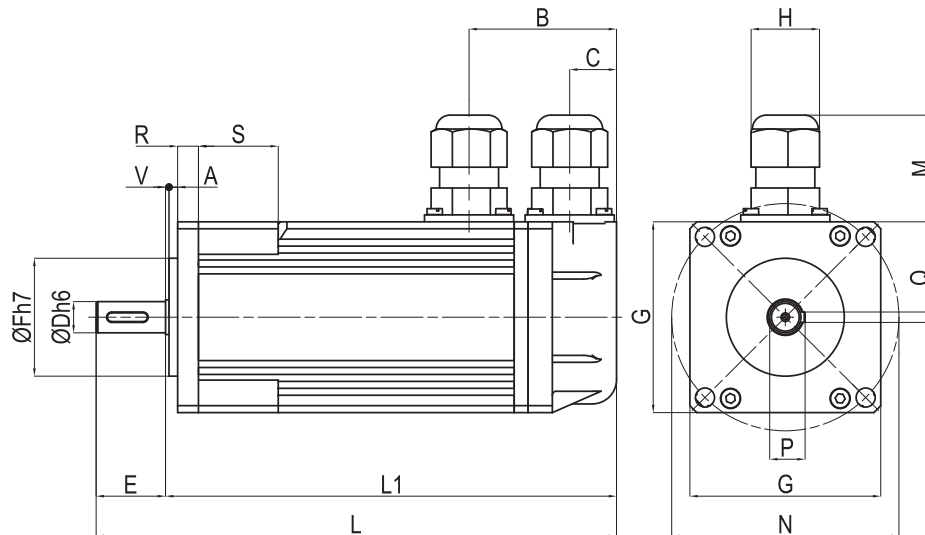

RP

Resolver - cable clamp with cables 98.4 in long

Resolver - prensaestopas con cables L=98.4 in

BS... RP

Type Tipo	A	B	C	D	E	F	G	H	L	L1
BS 35/30 RP	0.059	1.437	0.472	0.197	0.591	0.866	1.378	0.748	4.803	4.213
BS 35/60 RP	0.059	1.437	0.472	0.197	0.591	0.866	1.378	0.748	5.984	5.394
BS 45/35 RP	0.079	1.850	0.492	0.236	0.807	0.984	1.771	0.748	5.472	4.665
BS 45/70 RP	0.079	1.850	0.492	0.236	0.807	0.984	1.771	0.748	6.850	6.043
BS 55/50 RP	0.098	1.673	0.492	0.354	0.768	1.339	2.165	0.748	5.906	5.138
BS 55/100 RP	0.098	1.673	0.492	0.354	0.768	1.339	2.165	0.748	7.874	7.106
BS 80/50 RP	0.118	1.791	0.492	0.551	1.181	1.772	3.150	0.748	6.811	5.630
BS 80/100 RP	0.118	1.791	0.492	0.551	1.181	1.772	3.150	0.748	8.780	7.598

Type Tipo	M	N	P	Q	R	S	T	V	Weight Peso lb
BS 35/30 RP	0.827	1.673	-	-	0.157	0.591	0.138	0.019	0.772
BS 35/60 RP	0.827	1.673	-	-	0.157	0.591	0.138	0.019	1.257
BS 45/35 RP	0.925	2.087	-	-	0.197	0.787	0.169	0.019	1.632
BS 45/70 RP	0.925	2.087	-	-	0.197	0.787	0.169	0.019	2.359
BS 55/50 RP	0.925	2.579	0.409	0.118	0.236	0.906	0.217	0.039	2.844
BS 55/100 RP	0.925	2.579	0.409	0.118	0.236	0.906	0.217	0.039	4.860
BS 80/50 RP	0.925	3.858	0.630	0.197	0.315	1.181	0.256	0.079	5.292
BS 80/100 RP	0.925	3.858	0.630	0.197	0.315	1.181	0.256	0.079	8.599

For the self-braking version add the letter K to the model code. Measurements L, L1 increase by: 0.945 in (BS35), 1.102 (BS45), 1.142 (BS55), 1.535 (BS80).

En la version freno, añadir la letra K a la sigla del tipo. Las cotas L, L1 aumentan de: 0.945 in (BS35), 1.102 (BS45), 1.142 (BS55), 1.535 (BS80).

TORQUE CURVES - BS SERIES / CURVAS DE PAR - SERIE BS

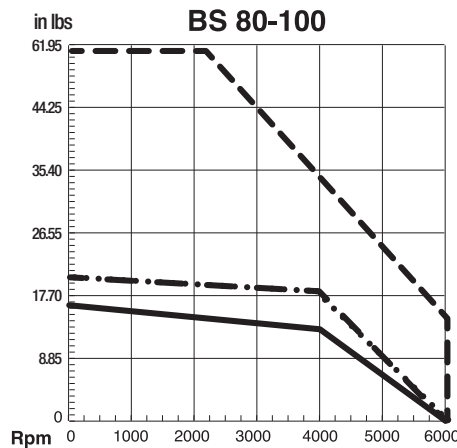
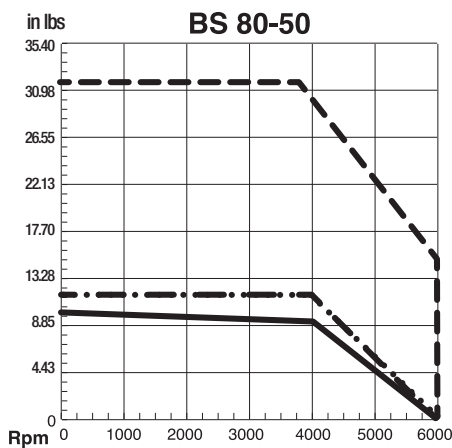
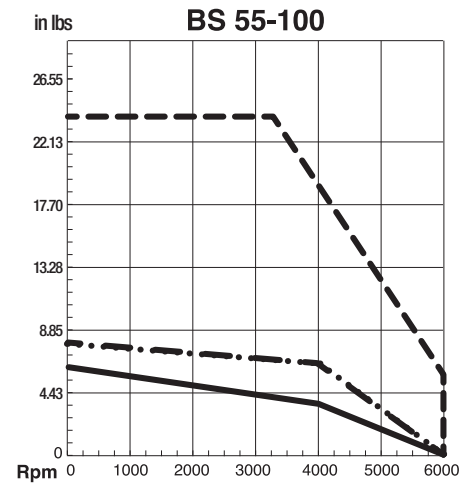
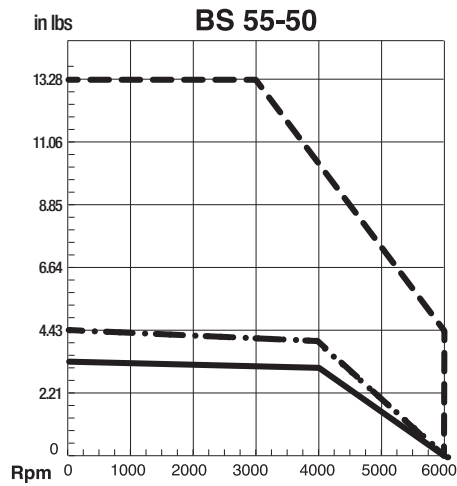
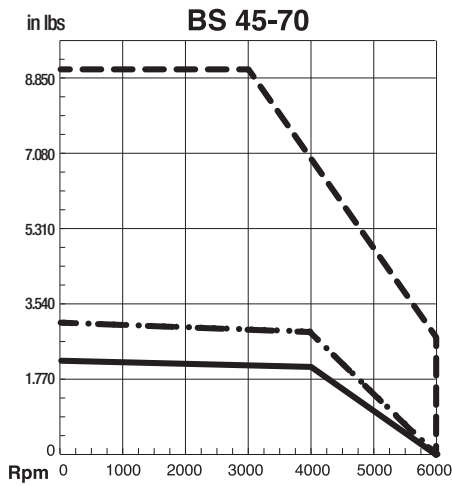
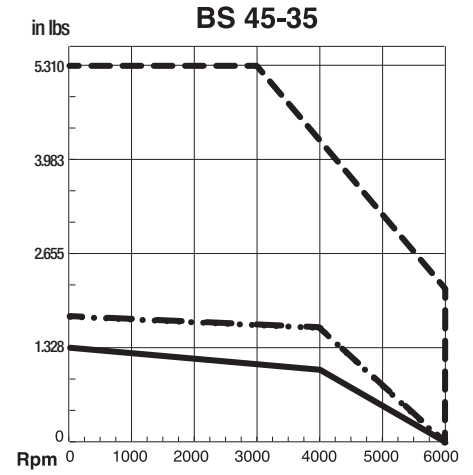
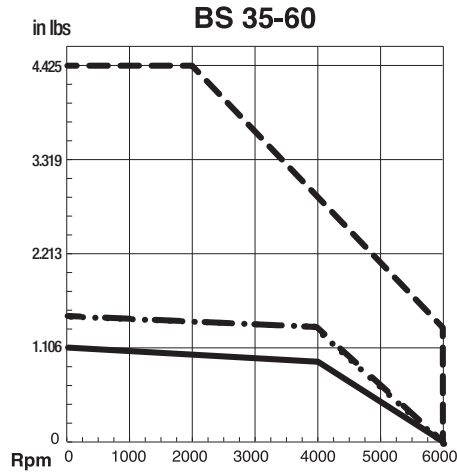
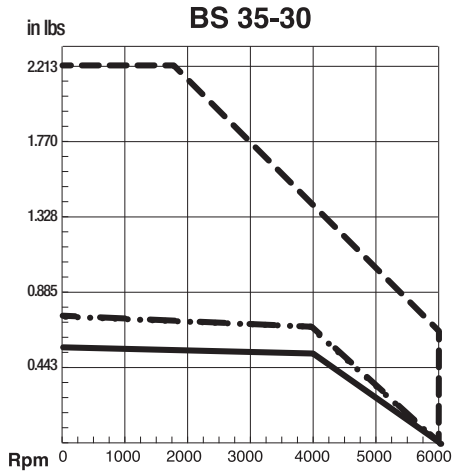

- MAX TORQUE**
PAR MÁX
- NOMINAL TORQUE WITH MOTOR COUPLED TO THE FLANGE $\Delta T=194^{\circ}F$**
- PAR NOMINAL CON MOTOR UNIDO A BRIDA $\Delta T=194^{\circ}F$**
- NOMINAL TORQUE WITH MOTOR UNCOUPLED $\Delta T=194^{\circ}F$**
- PAR NOMINAL CON MOTOR AL AIRE $\Delta T=194^{\circ}F$**