

17HDN SERIES 1.8°

Key Features

- High Torque
- High Accuracy
- Smooth Movement

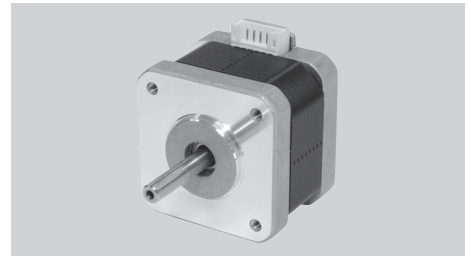

General Specifications

- Bi-polar

Series & Length	Model Number	Holding Torque		Rated Current	Resistance per Phase	Inductance per Phase	Detent Torque		Rotor Inertia	
		mNm	oz-in	A	ohm	mH	mNm	oz-in	g.cm ²	oz-in ²
17HD4N 34.3 mm (1.35 in.)	17HD4022-01N	220	31.18	1.1	3	4.2	12	1.7	38	0.21
	17HD4024N	300	42.52	0.5	15	20				
	17HD4025N	250	35.43	0.25	54	78				
17HD2N 39.8 mm (1.57 in.)	17HD2011N	380	53.85	1.5	1.9	4	15	2.12	57	0.31
	17HD2018N	450	63.78	0.85	8	14				
	17HD2026N	460	65.19	1	4.4	10				
	17HD2027N	450	63.78	0.25	71.4	140				
17HD6N 48.3 mm (1.90 in.)	17HD6012N	430	60.94	1.5	2.4	5.1	25	3.54	82	0.45
	17HD6016N	600	85.03	1	5.3	10				
	17HD6017N	480	68.03	0.85	7.5	14				
	17HD6019N	500	70.86	0.25	80	130				
	17HD6020N	540	76.53	0.5	20	35				
17HDBN 62.8 mm (2.47 in.)	17HDB001N	730	103.5	1.5	2.3	4.6	30	4.25	123	0.68
	17HDB002N	800	113.4	2	1.6	3				

- Uni-polar

Series & Length	Model Number	Holding Torque		Rated Current	Resistance per Phase	Inductance per Phase	Detent Torque		Rotor Inertia	
		mNm	oz-in	A	ohm	mH	mNm	oz-in	g.cm ²	oz-in ²
17HD4N 34.3 mm (1.35 in.)	17HD4030N	220	31.18	1.2	2.4	2	12	1.7	38	0.21
	17HD4031N	200	28.34	0.95	4.2	2.4				
	17HD4032N	220	31.18	0.4	24	13				
	17HD4033N	220	31.18	0.31	38.5	21				
17HD2N 39.8 mm (1.57 in.)	17HD2032N	260	36.85	1.4	1.8	1.7	15	2.12	57	0.31
	17HD2033N	280	39.68	0.8	7.5	6.9				
17HD6N 48.3 mm (1.90 in.)	17HD6023N	360	51.02	1	4.6	4	25	3.54	82	0.45
	17HD6024N	330	46.77	0.4	30	21.6				
	17HD6025N	390	55.27	0.8	7.5	7.3				
	17HD6026N	360	51.02	1.4	2.4	2.2				
17HDBN 62.8 mm (2.47 in.)	17HDB003N	460	65.19	1.5	2.3	2.4	30	4.25	123	0.68
	17HDB004N	500	70.86	2	1.6	1.6				

- Wiring Connection, Lead Wires, Schematic Diagrams & Stepping Sequence.....Page 62 - 64

Mechanical Dimension

Series	L	Mass
	mm (in.)	kg (lb.)
17HD4N	34.3 (1.35)	0.21 (0.46)
17HD2N	39.8 (1.57)	0.28 (0.62)
17HD6N	48.3 (1.90)	0.36 (0.79)
17HD8N	62.8 (2.47)	0.60 (1.32)

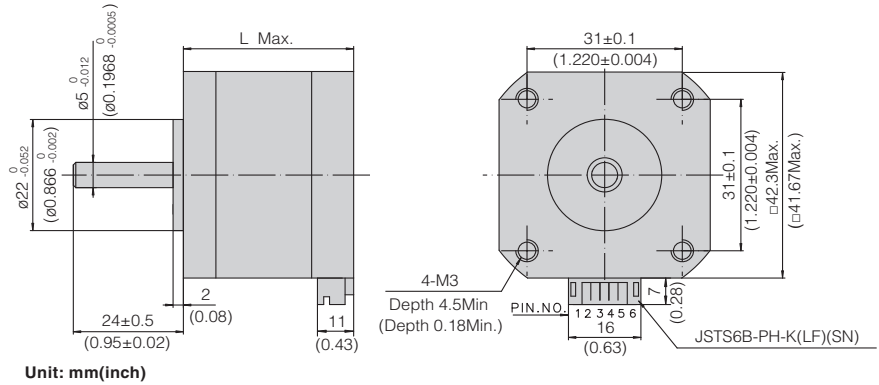

Dynamic Torque Curves

Bi-polar

17HD4022-01N

Conditions: Bi-polar Constant Current Driver
 Driver: AMA MS3540M
 Mode: Full Step

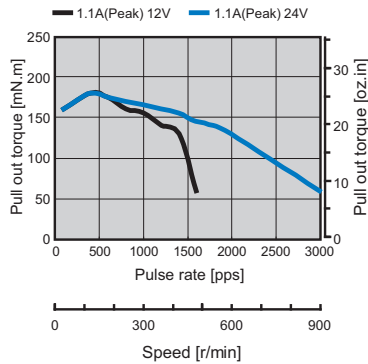

17HD4024N

Conditions: Bi-polar Constant Current Driver
 Driver: AMA MS3540M
 Mode: Full Step

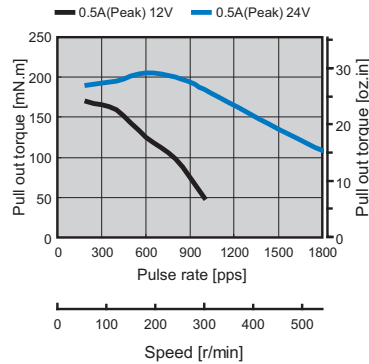

17HD4025N

Conditions: Bi-polar Constant Current Driver
 Driver: AMA MS3540M
 Mode: Full Step

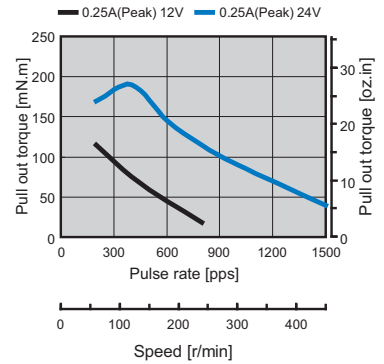

17HD2011N

Conditions: Bi-polar Constant Current Driver
 Driver: AMA MS3540M
 Mode: Full Step

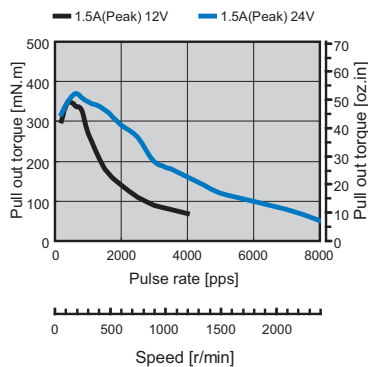

17HD2018N

Conditions: Bi-polar Constant Current Driver
 Driver: AMA MS3540M
 Mode: Full Step

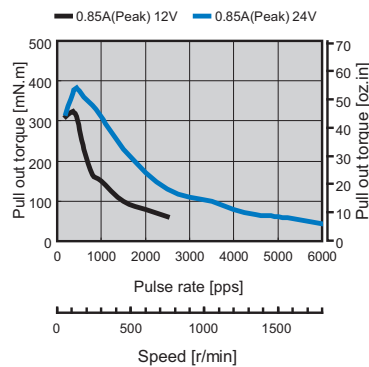

17HD2026N

Conditions: Bi-polar Constant Current Driver
 Driver: AMA MS3540M
 Mode: Full Step

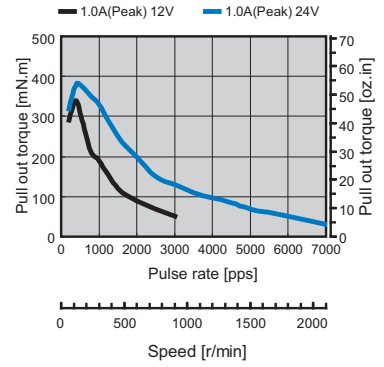

Dynamic Torque Curves

- Bi-polar

17HD2027N

Conditions: Bi-polar Constant Current Driver
 Driver: AMA MS3540M
 Mode: Full Step

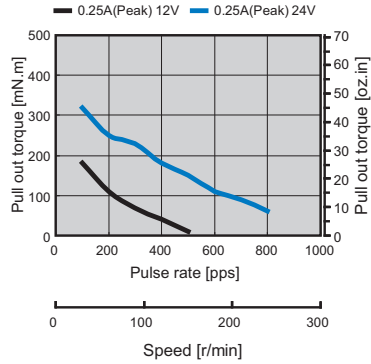

17HD6012N

Conditions: Bi-polar Constant Current Driver
 Driver: AMA MS3540M
 Mode: Full Step

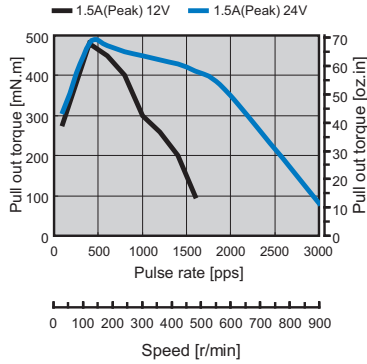

17HD6016N

Conditions: Bi-polar Constant Current Driver
 Driver: AMA MS3540M
 Mode: Full Step

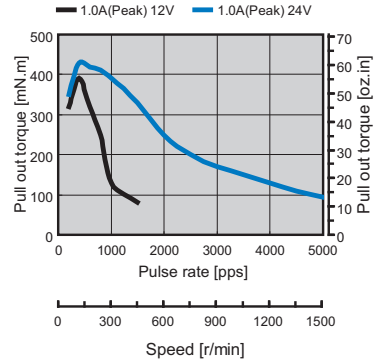

17HD6017N

Conditions: Bi-polar Constant Current Driver
 Driver: AMA MS3540M
 Mode: Full Step

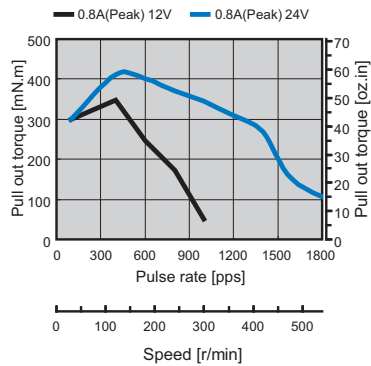

17HD6019N

Conditions: Bi-polar Constant Current Driver
 Driver: AMA MS3540M
 Mode: Full Step

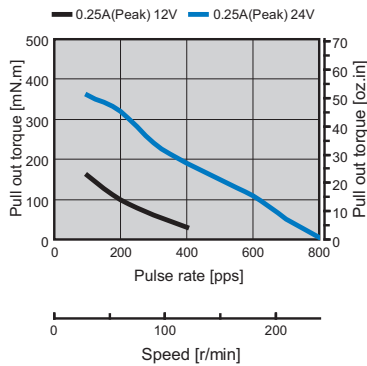

17HD6020N

Conditions: Bi-polar Constant Current Driver
 Driver: AMA MS3540M
 Mode: Full Step

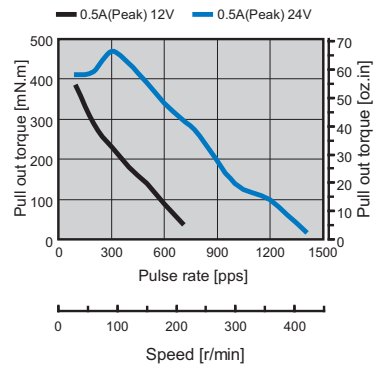

17HDB001N

Conditions: Bi-polar Constant Current Driver
 Driver: AMA MS3540M
 Mode: Full Step

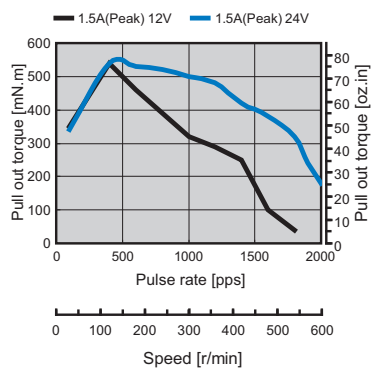

17HDB002N

Conditions: Bi-polar Constant Current Driver
 Driver: AMA MS3540M
 Mode: Full Step

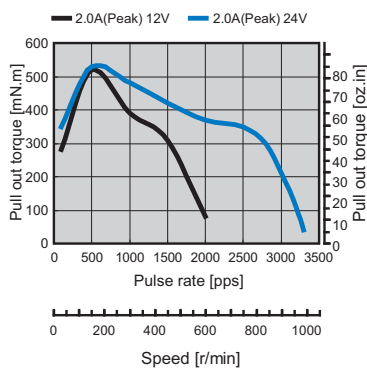

Dynamic Torque Curves

- Uni-polar

17HD4030N

Conditions:Uni-polar Constant Current Driver
Driver: AMA MSU3040M
Mode:Full Step

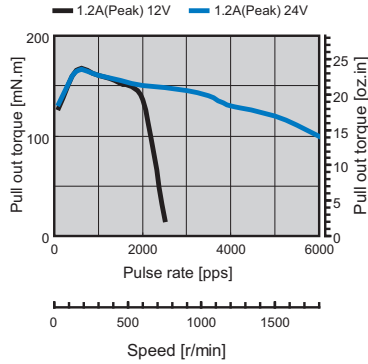

17HD4031N

Conditions:Uni-polar Constant Current Driver
Driver: AMA MSU3040M
Mode:Full Step

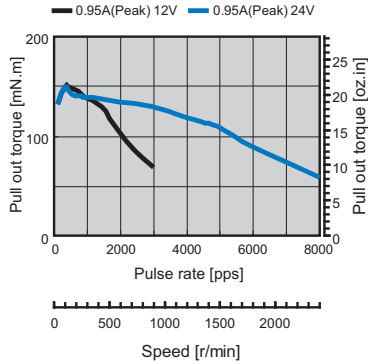

17HD4032N

Conditions:Uni-polar Constant Current Driver
Driver: AMA MSU3040M
Mode:Full Step

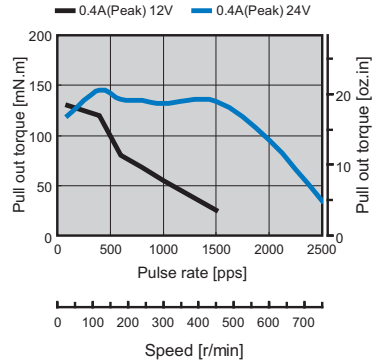

17HD4033N

Conditions:Uni-polar Constant Current Driver
Driver: AMA MSU3040M
Mode:Full Step

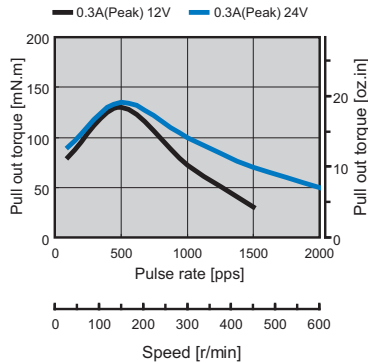

17HD2032N

Conditions:Uni-polar Constant Current Driver
Driver: AMA MSU3040M
Mode:Full Step

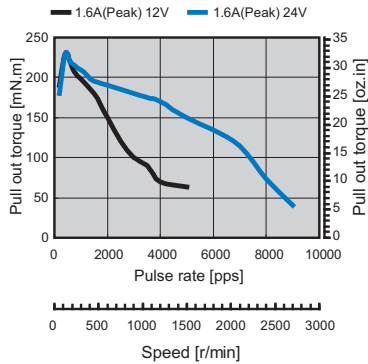

17HD2033N

Conditions:Uni-polar Constant Current Driver
Driver: AMA MSU3040M
Mode:Full Step

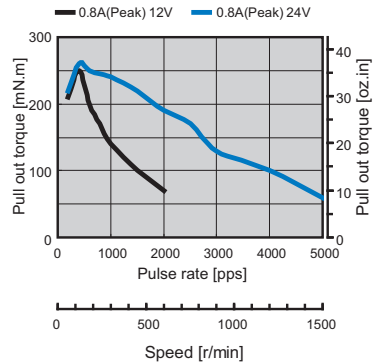

17HD6023N

Conditions:Uni-polar Constant Current Driver
Driver: AMA MSU3040M
Mode:Full Step

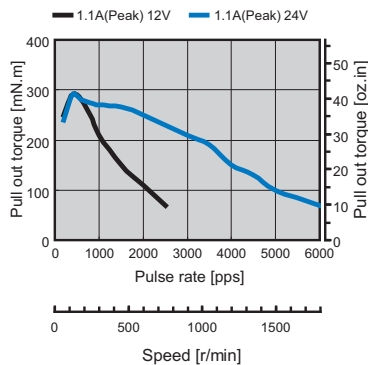

17HD6024N

Conditions:Uni-polar Constant Current Driver
Driver: AMA MSU3040M
Mode:Full Step

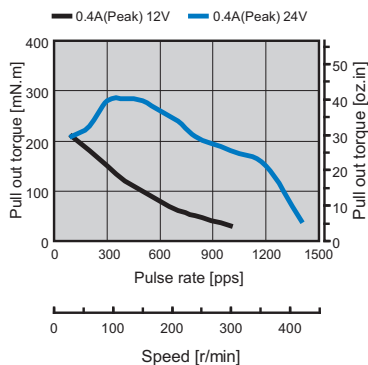

17HD6025N

Conditions:Uni-polar Constant Current Driver
Driver: AMA MSU3040M
Mode:Full Step

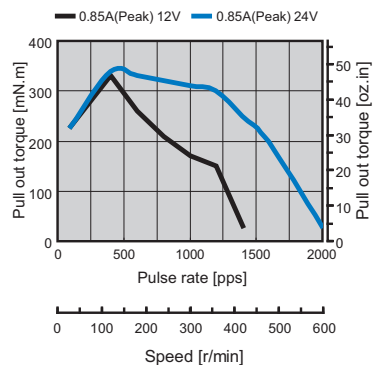

Dynamic Torque Curves

- Uni-polar

17HD6026N

Conditions: Uni-polar Constant Current Driver
 Driver: AMA MSU3040M
 Mode: Full Step

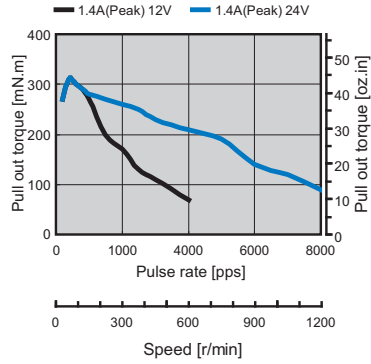

17HDB003N

Conditions: Uni-polar Constant Current Driver
 Driver: AMA MSU3040M
 Mode: Full Step

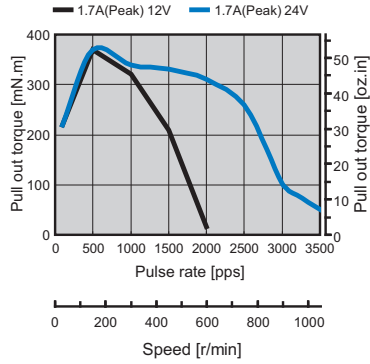

17HDB004N

Conditions: Uni-polar Constant Current Driver
 Driver: AMA MSU3040M
 Mode: Full Step

