



PowerTrac™ PRECISION BALL SCREW ASSEMBLIES

PowerTrac™ METRIC SCREW ASSEMBLIES

PRECISION BALL SCREW ASSEMBLY TECHNICAL INTRODUCTION

80-94

- Glossary and Technical Data 80-85
- Ball Screw Selection 86-87
- Application Examples 88-89
- Life Expectancy, Column Strength and Critical Speed: SRT, XPR and SGT Screws 90-93
- Ball Screw Screw and Nut Selection 94

LUBRICATION FOR PRECISION BALL SCREW ASSEMBLIES

95

INCH BALL SCREW AND NUT TECHNICAL DATA

96-144

- Ball Screw and Nut Characteristics Defined 96-97
- Reference Number System: Ball Screws and Nuts 98
- Inch Ball Screws and Nuts: SRT, XPR and SGT 99-143
- Quick Reference Chart: SRT, XPR and SGT 144

INCH BALL SCREW ASSEMBLIES

145-147

INCH TWIN-LEAD BALL SCREW ASSEMBLIES

148-149

METRIC BALL SCREW AND NUT TECHNICAL DATA

150-174

- Metric Screw and Nut Introduction 150
- Life Expectancy, Column Strength and Critical Speed: MRT, PMT and CARRY™ 151-153
- Reference Number System: Metric Screws and Nuts 154
- Metric Screws and Nuts: MRT, PMT and CARRY™ 155-173
- Quick Reference Chart: MRT, PMT and CARRY™ 174



PowerTrac™ Precision Ball Screw Assemblies



BALL SCREW FORM TERMS

INTRODUCTION

Ball screws offer an efficient means of converting rotary motion to linear motion. A ball screw is an improvement over an acme screw just as an antifriction ball bearing is an improvement over a plain bushing.

Ball screw assemblies have a number of bearing balls that transfer the load between the nut and screw. The thread form in which the bearing balls ride is an ogival shape formed from two arcs of the same radius with offset centers. This form is also referred to as a gothic arch. (SEE FIG. 1)

FIG. 1

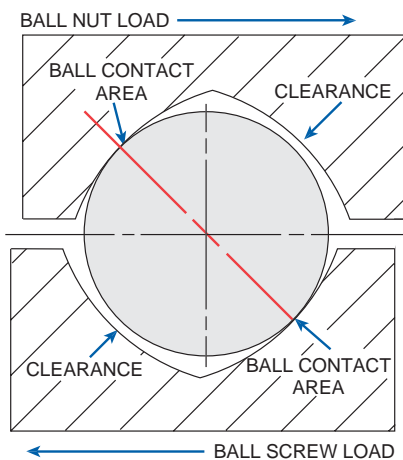

BEARING BALL CIRCUIT

The closed path that the bearing balls follow through the ball nut. Ball nuts may have one or more circuits.

RETURN GUIDE

When bearing balls circulate in a ball nut, a ball enters the ball path between the nut and screw carrying the load one or more turns around the screw. The bearing ball is then picked up and returned to the beginning of the circuit through the return guide.

LOAD CARRYING BALLS

The bearing balls in contact with ball nut and ball screw sharing the load.

LAND DIAMETER

The outside diameter of the screw. This diameter is less than the ball circle diameter.

BALL CIRCLE DIAMETER

The diameter of the circle generated by the center of the bearing balls when in contact with the screw and nut.

ROOT DIAMETER

The diameter of the screw measured at the bottom of the thread. This is the diameter used for column strength, critical speed calculations and end machining considerations.

PITCH

The axial distance between threads. Pitch is equal to the lead in a single start screw.

LEAD

The axial distance the nut advances in one revolution of the screw. The lead is equal to the pitch times the number of starts.

PITCH x STARTS = LEAD

SCREW STARTS

The number of independent threads on the screw shaft; typically one, two or four. (SEE FIG. 2)

LEAD ACCURACY

Lead accuracy is the difference between the actual distance traveled versus the theoretical distance traveled based on lead. For example: A screw with a .5 inch lead and ±.001 inch per foot lead accuracy rotated 24 times theoretically moves the nut 12 inches.

24 Revolutions X .500 inches per revolution = 12.000 inches of travel with a Lead accuracy of .001 per foot, actual travel could be from 11.999 to 12.001 inches.

FIG. 2

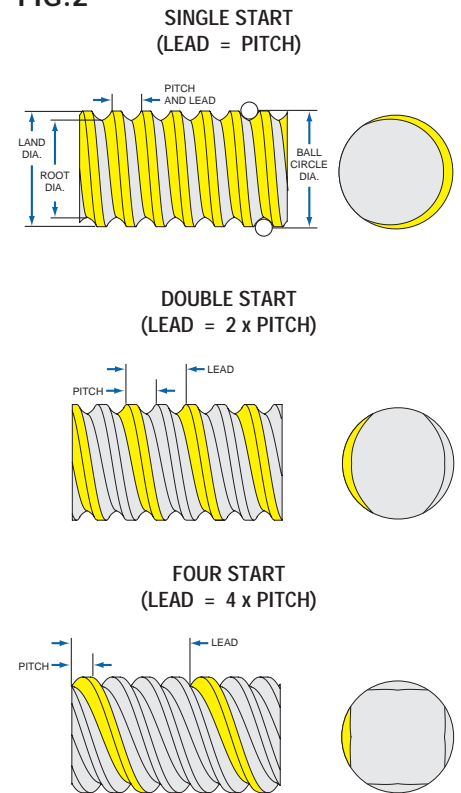

PowerTrac™ SRT Ball Screws

will not deviate from nominal lead by more than ±.004 inch/foot on screws through 2 1/2" diameter and ±.008 inch/foot on screws 3" and over.

PowerTrac™ XPR Ball Screws

will not deviate from nominal lead by more than ±.001 inch/foot.

PowerTrac™ SGT Ball Screws

will not deviate from nominal lead by more than ±.0005 inch/foot.

MATCHED LEAD

When multiple screws are used to move a load with precise synchronicity, screws of similar lead accuracy can be factory selected and supplied as sets. Consult factory for matched lead set tolerances.



STRAIGHTNESS

Although PowerTrac™ Ball Screws are manufactured from straight, cylindrical material, internal stresses may cause the material to bend or yield. When ordering random lengths or cut material without end machining, straightening is recommended. Handling or machining of screws can also cause the material to bend or yield. Before, during and after machining, additional straightening is required.

When ordering screws with machined ends from Nook Industries, the following straightness tolerances can be expected:

PowerTrac™ SRT and XPR Ball Screws are straight within .010 inch/foot when shipped from the factory, and do not exceed .030 inch in any 6 foot section.

PowerTrac™ SGT Ball Screws are straight within .001 inch/foot when shipped from the factory.

LIFE

A ball screw assembly uses rolling elements to carry a load similar to an anti-friction (ball) bearing. These elements do not wear during normal use. Therefore, ball screw life is predictable and is determined by calculating the fatigue failure of the components.

Proper lubrication, regular maintenance, and operation within specified limits will allow PowerTrac™ Ball Screws to operate to the predicted life.

EFFICIENCY

The low coefficient of friction of the rolling elements of PowerTrac™ Ball Screws and Nuts results in an operating efficiency greater than 90%.

BACKDRIVING

Normally, ball screws are used to convert rotary motion into linear motion. Backdriving is the result of the load pushing axially on the screw or nut to create rotary motion.

All ball screws, due to their high efficiency, will backdrive. The resulting torque is known as “backdriving torque” and is the torque required to hold a load in position.

CAUTION - When using ball screws, applications should be analyzed to determine the necessity of a brake, especially when the possibility of injury may occur.

BACKLASH

Backlash (lash) is the relative axial movement between a screw and nut without rotation of the screw or nut. The axial movement between a new PowerTrac™ SBN or SGN ball nut and screw will range from .003" to .015" depending on size. Lash in ball screws will remain constant during normal use.

SELECTIVE FIT

When less than standard lash (listed above) is desired, SBN and SGN ball nuts can be custom-fit to a specific screw with selected bearing balls to minimize lash to .003" to .005" depending on ball size. Select fitting may result in lower life.

LOAD DEFINITIONS

STATIC LOAD

The maximum thrust load – including shock – that can be applied to the ball nut without damaging the assembly.

DYNAMIC LOAD

The thrust load in pounds which, when applied to the ball nut and rotating screw assembly will result in a minimum life of 1,000,000 inches of travel. Metric screw

designs are per ISO 3408 and show the load ratings in kilonewtons for 1 million revolutions of the screw. For inch or metric rotating nut designs, contact Nook Industries at 800-321-7800.

TENSION LOAD

A load that tends to “stretch” the screw. (SEE FIG. 3)

COMPRESSION LOAD

A load that tends to “squeeze” the screw. (SEE FIG. 3)

OVERTURNING LOAD

A load that tends to rotate the nut

FIG.3

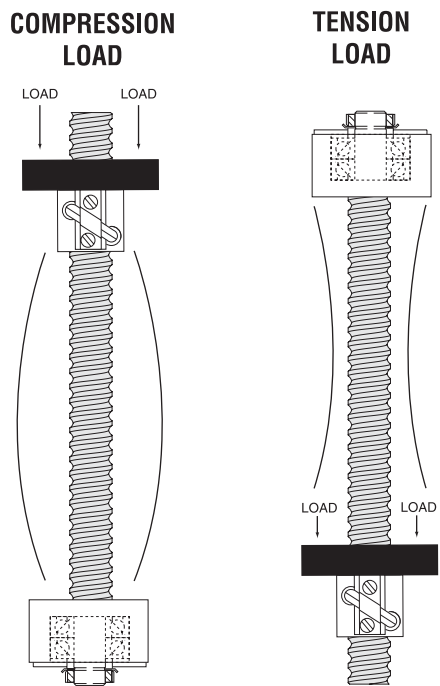

around the longitudinal axis of the screw. (SEE FIG. 4)

SIDE LOAD

A load that is applied radially to the nut. (SEE FIG. 4)

FIG.4

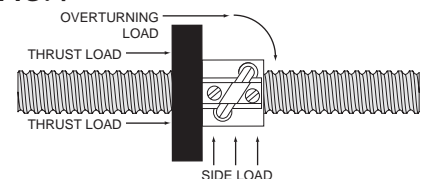

GLOSSARY AND TECHNICAL DATA

CAUTION - Although a side load will not prevent the ball screw from operating, the nut is not designed to operate with a side load, such as those generated from pulleys, drive belts, misalignment, etc. See "Load Definition" section for further information.

THRUST LOAD

A load parallel to and concentric with the axis of the screw.

(SEE FIG. 4)

PRELOAD

Preload is an internal force introduced between a ball nut and screw assembly that eliminates free axial and radial lash. Preloaded assemblies provide excellent repeatability and increased system stiffness.

Preloading is achieved either by using two nuts and forcing them apart or by shifting the circuits within a single nut. Nook Industries has a variety of preload ball nut designs available. (SEE FIG. 5)

FIG. 5

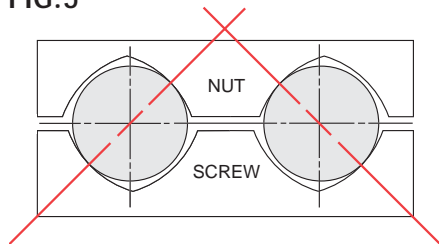

DESIGN CONSIDERATIONS

MOUNTING AND PINNING OF BALL NUT FLANGE

If a flange is used, it must be permanently fixed to the nut. Since mounting methods usually require the disassembly of the ball nut from the screw, it is best to order the nut and flange factory assembled.

The preferred method of locking a flange to a nut is a pin or set screw parallel to the screw which intersects the flange/nut mounting

thread. Because of the dissimilarity of materials, the hole may need to be milled, not drilled. (SEE FIG. 6 & 7)

FIG. 6

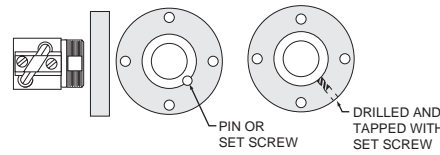

Alternatively, the flange may be drilled and tapped radially for a setscrew. After assembly of the flange to the nut, spot drill the nut threads through the flange and install a dog point set screw from the flange O.D. into the nut O.D. threads. Avoid getting metal chips in the nut when drilling.

Commercially available thread adhesives may be used for light load applications. Follow the manufacturers recommendations to ensure a satisfactory bond. Avoid getting the adhesive onto the ball tracks.

STANDARD FLANGE ORIENTATION

Standard flange orientation varies with the number of holes in the flange. Unless otherwise specified, a factory-assembled flange will be oriented on the nut as shown. (SEE FIG. 8)

FIG. 8

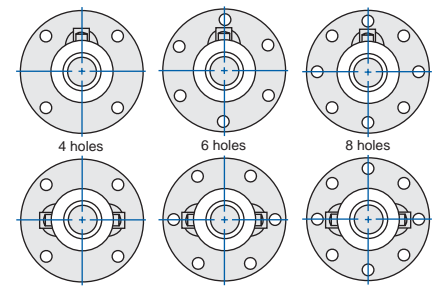

PROPER BALL NUT ORIENTATION

When a ball screw assembly is used in an orientation other than vertical, it is important to orient the return tubes to optimize ball nut operation. (SEE FIG. 9)

FIG. 9

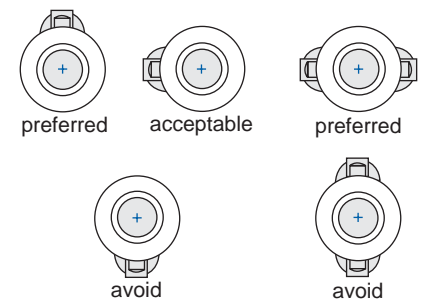

Ball nuts run best with the return guides up. Horizontal guide orientation is also acceptable. Return guides down should be avoided.

Some ball nut designs have return guides on both sides of the nut. In this case the preferred guide orientation is horizontal.

FIG. 7

DIAMETER	DESCRIPTION	QUANTITY
Up to 1	3/16 x 1/2 Slotted Spring Pin	1
1.125	3/16 x 1/2 Slotted Spring Pin	2
1.5	5/16 - 18 x 1/2 Set Screw	2
2.25 to 3.0	3/8 - 16 x 3/4 Set Screw	2
4	1/2 - 13 x 1 Set Screw	2

Note: Ball Nuts are case hardened.

TRANSFERRING BALL NUTS FROM SHIPPING ARBOR

When not ordered as part of an assembly, ball nuts are shipped on arbors. Transferring the ball nut from the arbor to the ball screw is achieved by placing the arbor against the end of the screw thread and carefully rotating the ball nut onto the screw from the arbor.

If the inside diameter of the arbor is too small to slip over the outside diameter of the journal, apply tape to the journal to bring the outside diameter up to the root diameter of the screw to prevent the bearing balls from falling out of the ball nut. The ball nut can then be transferred across the taped journal onto the ball screw. (SEE FIG. 10)

CAUTION - Removal of the arbor from the ball nut will result in the loss of the bearing balls. All of the bearing balls in a ball nut are matched. If any balls are lost during this transfer, they all must be replaced.

INSTALLING SEL, SAR, AND SAG BALL NUTS

These nuts must be transferred from the arbor to the screw without preload. Be sure to keep the ball return tubes aligned with each other and make sure the coupling tangs line up with the slots in the ball nut.

Center the adjusting nut on the coupling. Before preloading these ball nuts, all the coupling threads, spring washers/spacers and ball grooves should be lubricated.

Position the ball nut on the center of the screw shaft. It is a good idea to place retainers (tape, tie-straps, etc.) on the screw to prevent the ball nut from over-traveling. With the ball return tubes facing upward, tighten the adjusting nut against the spring washer or spacer by hand until it cannot be turned. While holding the ball nut with tubes

facing up, rotate the screw several turns in both directions.

Running torque can be measured by means of a spring scale. The force reading multiplied by the lever arm length yields the running torque value.

Make adjustments to achieve desired preload and recheck running torque value up and down the screw shaft. Do not tighten the adjusting nut to a point that fully collapses the spring washers.

After the system is adjusted, secure the adjusting nut with the set screws provided.

LUBRICATION

Proper and frequent lubrication must be provided to achieve predicted service life. A 90% reduction in the ball screw life

should be anticipated when operating the nut and screw without lubricants.

Standard lubrication practices for antifriction bearings should be followed when lubricating ball screws. A light oil or grease (lithium-based) is suitable for most applications. Lubricants containing additives such as molydisulfide or graphite should not be used.

E-900, Nook Ball Screw Lubricant, is oil that has been developed specifically for ball screws and is available as a spray or liquid. See page 95.

Lubrication intervals are determined by the application. It is required that screw assemblies are lubricated often enough to maintain a film of lubricant on the screw.

FIG. 10

1. Remove any ball nut retainer from arbor. Hold arbor firmly end to end with the screw. Make certain the arbor end is centered on the screw shaft end.

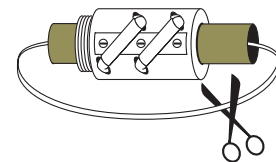

2. Slide the ball nut down the screw shaft and rotate counter to the thread until you feel the balls drop into the screw thread. Then rotate with the screw thread until the ball nut completely clears the end of the screw shaft adjacent to the arbor.

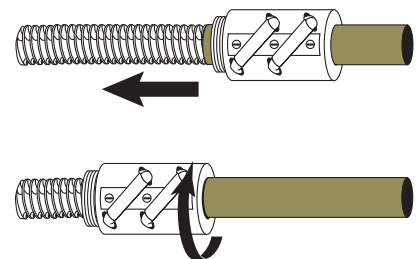

3. Remove the arbor.

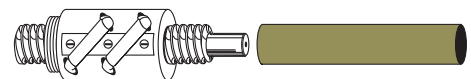

To transfer the ball nut from screw to arbor, reverse the above procedure.

CAUTION: Extreme care must be taken to prevent the ball nut from sliding off the end of the screw shaft during installation and handling. Temporary stops can be made by wrapping tape around shaft balls grooves at each end. Be sure to remove tape and any residual adhesive after the ball screw assembly is properly installed.

DRIVING TORQUE

Driving torque is the amount of torque required by the ball screw to move a load. To simplify this calculation a “torque to raise one pound or one kN” value is provided in the technical data for each ball screw size. (SEE FIG. 11)

To determine the required torque to move a load, multiply the load to be moved by the “torque to raise one pound or kN”. For more information on drive torque, see the application example at the end of the section.

FIG. 11

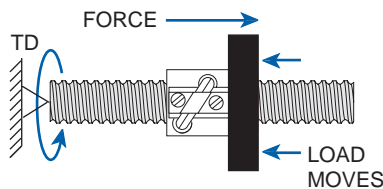

$$T_d = \frac{P \times L}{2\pi e} = .177 P \times L$$

WHERE:

- T_d = Drive Torque (pound-inches)
- P = Load (lbs.)
- L = Screw Lead (inches/turn)
- e = Ball Bearing Screw Efficiency (90%)

BACKDRIVING TORQUE

Due to the efficiency of a ball screw, a load applied to the ball nut will generate backdriving torque on the ball screw. The torque required to hold the load in position can be calculated by the following formula. (SEE FIG. 12)

FIG. 12

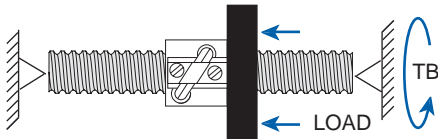

$$T_d = \frac{P \times L \times e}{2\pi} = .143 P \times L$$

WHERE:

- T_d = Drive Torque (pound-inches)
- P = Load (lbs.)
- L = Screw Lead (inches/turn)
- e = Ball Bearing Screw Efficiency (90%)

TEMPERATURE

PowerTrac™ Ball Nuts will operate between -65°F and 300°F with proper lubrication. PowerTrac™ ball nuts equipped with elastomeric wipers are limited to operation between -20°F and 180°F.

END MACHINING

To obtain optimum performance of your ball screw assembly, it is recommended that the machining be performed at the Nook Industries factory. Screws may be purchased machined to your specifications or to standard end machining designs shown on pages 212-213.

Annealed ends can be provided on SRT screws to facilitate end machining of journals.

EZZE-MOUNT™

Ball screws in operation generate an axial load and a radial load; therefore, end mounts must be designed to accommodate these loads. Nook Industries has designed precision end mounts to work specifically with lead screws. For a detailed description of these bearing supports see pages 214-218.

An EZZE-MOUNT™ can be shipped pre-assembled to a PowerTrac™ Ball Screw. For complete PowerTrac™ Ball Screw Assemblies refer to pages 145-147.

OPTIONAL SURFACE COATINGS

PowerTrac™ Ball Screws are available with optional corrosion resistant and/or lubricated finishes like Nickel, Teflon, or Hard Chrome; consult Nook Industries for detailed specifications.

WIPER KITS

It is recommended that wipers be used with ball nuts to prevent contamination from foreign materials. The product pages detail the different types of wipers available for or standard with each

ball nut. Brush wipers may require customer-supplied retention. For the different ways that this can be achieved (SEE FIG. 13).

FIG. 13

SOME EXAMPLES OF HOW TO ATTACH WIPERS TO V-THREAD END

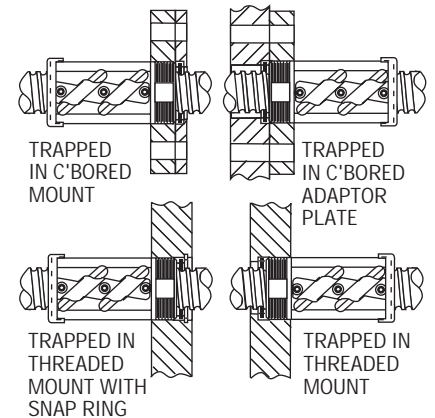

BOOTS AND BELLOWS

For contaminated environments, use of a boot or metal cover to protect the ball screw assembly is recommended.

POWERTRAC™ MATERIAL SPECIFICATIONS

PowerTrac™ Ball Screws are manufactured from high quality alloy steel, induction hardened to Rc 58-60.

PowerTrac™ Ball Nuts are manufactured from carburized steel with ball tracks heat treated to Rc 58-60.

SRT ball screws less than 16 ft. are given a protective black oxide finish. XPR and SGT ball screws are provided with a polished finish. Selected sizes are available in heat-treated stainless steel (Rc 40-45) for applications in corrosive environments. (SEE FIG. 14 on following page)



BALL SCREW SELECTION

The selection of the correct ball screw and nut for a particular application involves five interrelated factors. Before attempting to determine the ball screw and nut combination, the following values must be known:

- Load measured in pounds or newtons
- Speed measured in inches or millimeters per minute
- Length between bearings measured in inches or millimeters
- Life expectancy
- End fixity type

LOAD

The loads that need to be considered are the static loads, dynamic loads, reaction forces and any external forces affecting the screw. See Load definitions section above for details.

SPEED

The travel rate (linear speed) is the rpm at which the screw or nut is rotating multiplied by the lead of the screw.

LENGTH

Unsupported length of the screw.

LIFE EXPECTANCY

The dynamic load ratings shown on the product specification pages indicate the load that can be carried for 1,000,000 inches of travel.

The charts on pages 90-91 relate life to load. In applications where

the load is relatively constant over the entire stroke, use the highest load to select the ball screw to provide a factor of extra life. For applications where the loads vary significantly, an equivalent load can be calculated using the following formula:

$$L_m = \sqrt[3]{\frac{\%_1(L_1)^3 + \%_2(L_2)^3 + \%_3(L_3)^3 + \dots + \%_n(L_n)^3}{100}}$$

WHERE:

- L_m = equivalent load
- L_n = each increment of load
- $\%_n$ = percent of stroke at load L_n

FOR EXAMPLE:

- $L_1 = 150\#$ $\%_1 = 30\%$
- $L_2 = 225\#$ $\%_2 = 45\%$
- $L_3 = 725\#$ $\%_3 = 25\%$

$$L_m = \sqrt[3]{\frac{30(150)^3 + 45(225)^3 + 25(725)^3}{100}}$$

$L_m = 466$ lbs.

The life required is determined by multiplying the total stroke in inches by the total number of strokes required for the designed life of the equipment.

To calculate the travel life for a ball nut other than at rated load use the formula (SEE FIG. 15).

FIG. 15

$$T_x = \left(\frac{F_r}{F_x}\right)^3 \times T_r$$

WHERE:

- T_x = Travel other than rated load. Life is given in inches or meters
- F_r = Rated Load in pounds or kilonewtons
- F_x = Actual or Equivalent load in pounds or kilonewtons

T_r = Rated Travel Life. For inch screws this is equal to 1,000,000 inches. For Metric Screws this is equal to the ball nut lead in meters times one million revolutions.

END FIXITY

End fixity refers to the method by which the ends of the screw are supported. The degree of end fixity is related to the amount of restraint of the ends of the screw.

Three basic types of end fixity are:

Free No support.

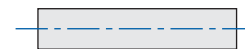

Simple Shaft supported at a single point.

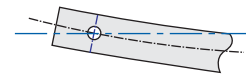

Fixed Shaft rigidly restrained against axial rotation.

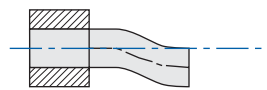

"Simple" end fixity can be provided through a single bearing support. Multiple or spaced pairs of bearings are more rigid than a "simple" support, but, because of their inherent compliance are not truly "fixed".

A screw can be supported with different combinations of end fixity. (SEE FIG. 16)

FIG. 14	ALLOY			STAINLESS STEEL
	SRT	XPR	SGT	
MATERIAL	4150 Series*	4150 Series*	4150 Series*	17- 4 PH
HARDNESS	Rc 58-60 Case Hardened	Rc 58-60 Case Hardened	Rc 58-60 Case Hardened	Rc 40-45 Thru Hardened
TENSILE	120,000 psi	120,000 psi	120,000 psi	150,000 psi
LEAD ACCURACY	±.004"/ft. thru 2-1/2" Dia.	±.001"/ft. thru 2-1/2" Dia.	±.0005"/ft. thru 2-1/2" Dia.	±.004"/ft.
FINISH	Roller Burnished, Black Oxide Finish(16 ft. or less)	Precision Roller Burnished	Precision Ground	Roller Burnished

*or equivalent

GLOSSARY AND TECHNICAL DATA

FIG. 16: A- D

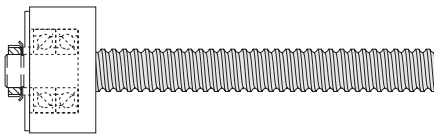

A: One end supported with a Double Bearing EZZE-MOUNT™, other end Free. Use Line "A" in reference to the charts shown on pages 92-93 and 152-153.

NOTE: Not recommended for any application other than short travels and slow speeds.

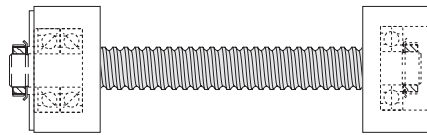

B: One end supported with a Double Bearing EZZE-MOUNT™, other supported with a Single Bearing EZZE-MOUNT™. Use Line "B" in reference to the charts shown on pages 92-93 and 152-153.

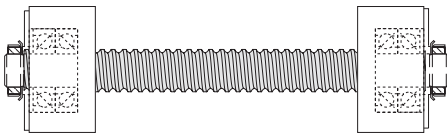

C: Both ends supported with a Double Bearing EZZE-MOUNT™. Use Line "C" in reference to the charts shown on pages 92-93 and 152-153.

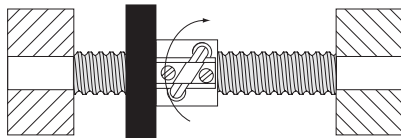

D: Both ends rigidly mounted with a rotating nut or both ends mounted with a double preloaded angular contact bearing spaced apart by at least 1.5 times the diameter of the mounting journal. Use Line "D" in reference to the charts shown on pages 92-93 and 152-153.

CRITICAL SPEED

The speed that excites the natural frequency of the screw is referred to as the critical speed. Resonance at the natural frequency of the screw will occur regardless of the screw

orientation (vertical, horizontal etc.) or if the system is designed so the nut rotates about the screw.

The critical speed will vary with the diameter, unsupported length, end fixity and rpm. Since critical speed can also be affected by shaft straightness and assembly alignment, it is recommended the maximum speed be limited to 80% of the calculated critical speed. The theoretical formula to calculate critical speed in rpm is:

$$N = \frac{C_s \times 4.76 \times 10^6 \times d}{L^2}$$

WHERE:

- N = Critical Speed
- d = Root Diameter of Screw
- L = Length Between Bearing Supports
- C_s = .36 for one end fixed, one end free
- 1.00 for both ends simple
- 1.47 for one end fixed, one end simple
- 2.23 for both ends fixed

The critical speed chart on page 93 or 153 is provided to quickly determine the minimum screw size applicable for Nook EZZE-MOUNT™ designs.

Maximum travel rate is also limited by ball velocity. The ball velocity is a function of the ball circle diameter and rotational speed. Ball velocity is limited by a maximum DN (ball circle diameter x rpm). The charts show the maximum speed based on the DN value for each screw in parentheses.

If the selected ball screw does not meet the speed criteria, consider the following options:

- a) Increase screw lead (reduce rpm)
- b) Change end fixity (e.g. simple to fixed)
- c) Increase ball circle diameter

The final consideration should be to recheck the selected screw against all three of the design criteria: life, column strength and critical speed.

COLUMN STRENGTH

When a screw is loaded in compression (see compression load definition on page 82), its limit of elastic stability can be exceeded and the screw will fail through bending or buckling.

The theoretical formula to calculate the column strength in pounds is:

$$P_{cr} = \frac{14.03 \times 10^6 \times F_c \times d^4}{L^2}$$

WHERE:

- P_{cr} = Maximum Load
- F_c = End Fixity Factor
- .25 for one end fixed, one end free
- 1.00 for both ends supported
- 2.00 for one end fixed, one end simple
- 4.00 for both ends rigid

d = Root Diameter of Screw

L = Distance between nut and load carrying bearing

The column strength chart, on page 92 or 152, may be used to verify that the screw can carry the required load without buckling.

The charts show the theoretical limitations of each screw on a separate line. The lines are limited horizontally by the slenderness ratio and vertically by the maximum static capacity of the nut. Actual load is limited by the maximum nut capacity.

If the selected screw does not meet compression load criteria, consider the following options:

- a) Change end fixity (e.g. simple to fixed)
- b) Design to use screw in tension
- c) Increase screw diameter



APPLICATION

Given the following requirements select a ball screw for the application which uses a ball screw for an automatic part feeder on a machine.

Specifications:

- 5000 lb. load supported and guided on linear bearings moving horizontally
- 36" travel
- Complete 36" travel in 10 seconds
- Bearing Support Undecided
- Positioning accuracy $\pm 1/4"$

STEP 1

Find the axial force required to move load. The axial force is determined by multiplying the coefficient of friction of the guidance system by the load.

$$F = \mu \times N$$

μ = coefficient of friction of the guidance system

Using Nook linear bearings in this application;
 μ = Coefficient of Friction for lubricated Nook Linear Bearings = .0013
 (Refer to linear ball bearing engineering data found on page 223.)

$$N = \text{Load} = 5000 \text{ pounds}$$

$$F = \mu \times N$$

$$F = .0013 \times 5000 \text{ lbs.}$$

$$F = 6.5 \text{ lbs.}$$

Therefore:

The Axial Force the screw must produce to move the load is 6.5 lbs.

STEP 2

Find Average Travel Rate. The average travel rate is determined by dividing travel distance by travel time.
 $V \text{ average} = D/t$

$$D = \text{distance} = 36 \text{ inches}$$

$$t = \text{total time} = 10 \text{ seconds}$$

$$V \text{ avg.} = D/t$$

$$V \text{ avg.} = 36 \text{ in.} / 10 \text{ sec.}$$

$$V \text{ avg.} = 3.69 \text{ in} / \text{sec. or } 216 \text{ in/minute}$$

Therefore the average travel rate is 216 in/min.

STEP 3

Find Maximum Travel Rate. When considering critical speed, peak velocity should be used. Using a basic triangular motion profile (acceleration = deceleration with no constant velocity travel), the peak velocity equals twice the average velocity.

$$V \text{ peak} = 2 \times V \text{ avg.}$$

$$V \text{ avg.} = 3.6 \text{ in} / \text{sec. or } 216 \text{ in/minute}$$

$$V \text{ peak} = 2 \times 216 V \text{ avg.}$$

$$V \text{ peak} = 432 \text{ in/min}$$

The Maximum Travel Rate is 432 in/min during the traverse of 36 inches in 10 seconds.

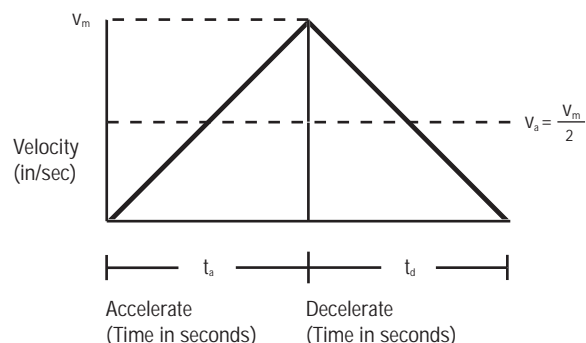

APPLICATION EXAMPLE

STEP 4

Determine total unsupported length. Total Travel is given as 36 inches, but extra screw length should be considered for travel nut, carriage, and any extra screw length for over travel.

Based on the travel nut and attachment of the nut to the carriage in this application it is determined an extra 4" of screw length will be required.

(Refer to the dimensional information of the particular nut used)

$$L \text{ total} = 36 \text{ in} + 4 \text{ in} = 40 \text{ inches}$$

The total unsupported length to be used for critical speed and column loading calculations is 40 inches.

STEP 5

Determining end fixity. The layout of the application shows that adequate space is available to use a double bearing EZZE-MOUNT™ at each end.

(See end fixity definitions on page 86-87)

$$\text{End Fixity} = \text{Type "C"}$$

STEP 6

Select a screw based on the critical speed. Use previously determined values with the Critical Speed chart on page 93.

$$\text{Max Travel Rate} = 432 \text{ in/min}$$

$$\text{End Fixity} = \text{Type "C"}$$

$$\text{Length between bearings} = 40 \text{ inches}$$

Based on the Critical Speed Chart, the best choice, appears to be a 1000-0250 SRT. Since the lead of the 1000-0250 SRT ball screw is .250", the maximum rpm needed to achieve the maximum travel rate would be 1728 rpm.

STEP 7

Check Column Strength of screw. Use previously determined values with the Column Strength Chart.

$$\text{Load} = 6.5 \text{ pounds}$$

$$\text{End Fixity} = \text{Type "C"}$$

$$\text{Length Between Bearing Supports} = 40 \text{ inches}$$

Based on the Column Strength Chart the load is within the column strength of this screw.

NOTE: Note: If this were a vertical application the full 5000 lb. load would be used. Also under high acceleration conditions the inertia load must be determined and added to the total load for column considerations.

STEP 8

Create a reference number for the assembly. See page 98 for Reference Number System Chart.

The 1000-0250 SRT thread form is desired in a Right hand thread. The end code used for machining this screw is end code 20. The type of end machining will be a Type 3 on both ends of the screw to allow for the mounting of double bearing EZZE-MOUNT™. One of the ends will have an extension to attach a coupling, the other will not. To determine the overall length of the assembly, add up the length of the ends plus the unsupported length:

$$\text{One end Type 3K (drive end with keyway)} = 4.03"$$

$$\text{One end Type 3N (no drive end)} = 2.71"$$

$$40 \text{ inches between supports}$$

$$\text{Overall length: } 40" + 4.03" + 2.71" = 46.74"$$

The Parts List Includes:

- 1000-0250 SRT Ball Screw
- Ball Nut Number: SBN7508
- Flange Number: FLG7571
- EZZE-MOUNT™: EZM-2020 – 2 required

To receive an assembly of these components with the EZZE-MOUNT™, nut, and flange installed on the screw, the order reference number is:

1000-0250 SRT RH/EK/EN/46.74/SBN7508/FS

LIFE EXPECTANCY: INCH SRT ROLLED



TO USE THIS CHART:

- 1) Determine required Life (in million inches of travel) at equivalent operating load.
 - 2) Find point at which load and life requirement intersect.
 - 3) Select ball nut to the right or above the intersect point.
- NOTE:** IF USING A BALL SCREW WITHOUT LUBRICANT DE-RATE LIFE BY 90%

PRECISION BALL SCREW ASSEMBLY TECHNICAL INTRODUCTION

Alloy Steel Screws

Stainless Steel Screws

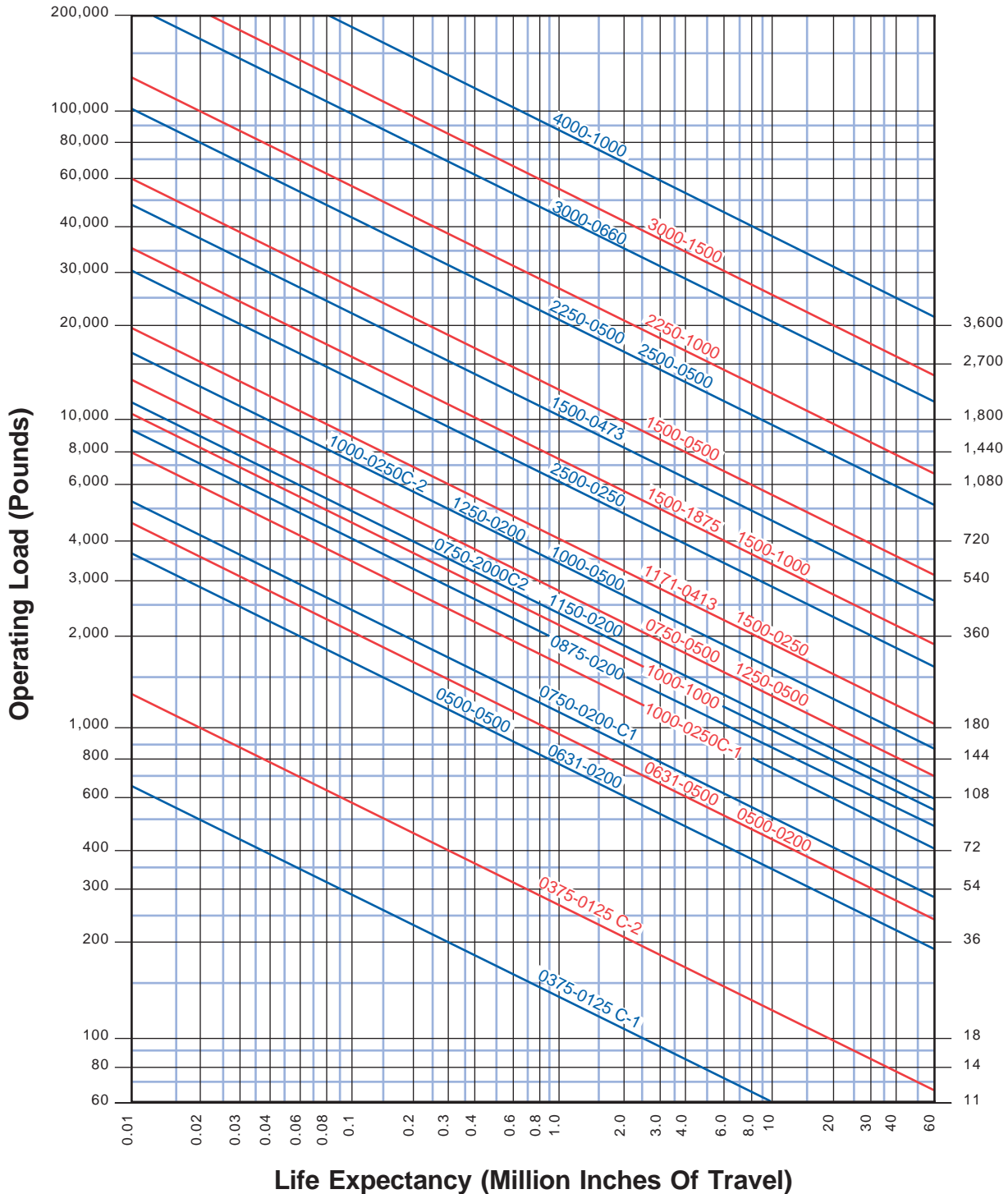

TO USE THIS CHART:

- 1) Determine required Life (in million inches of travel) at equivalent operating load.
 - 2) Find point at which load and life requirement intersect.
 - 3) Select ball nut to the right or above the intersect point.
- NOTE:** IF USING A BALL SCREW WITHOUT LUBRICANT DE-RATE LIFE BY 90%

PRECISION BALL SCREW ASSEMBLY TECHNICAL INTRODUCTION

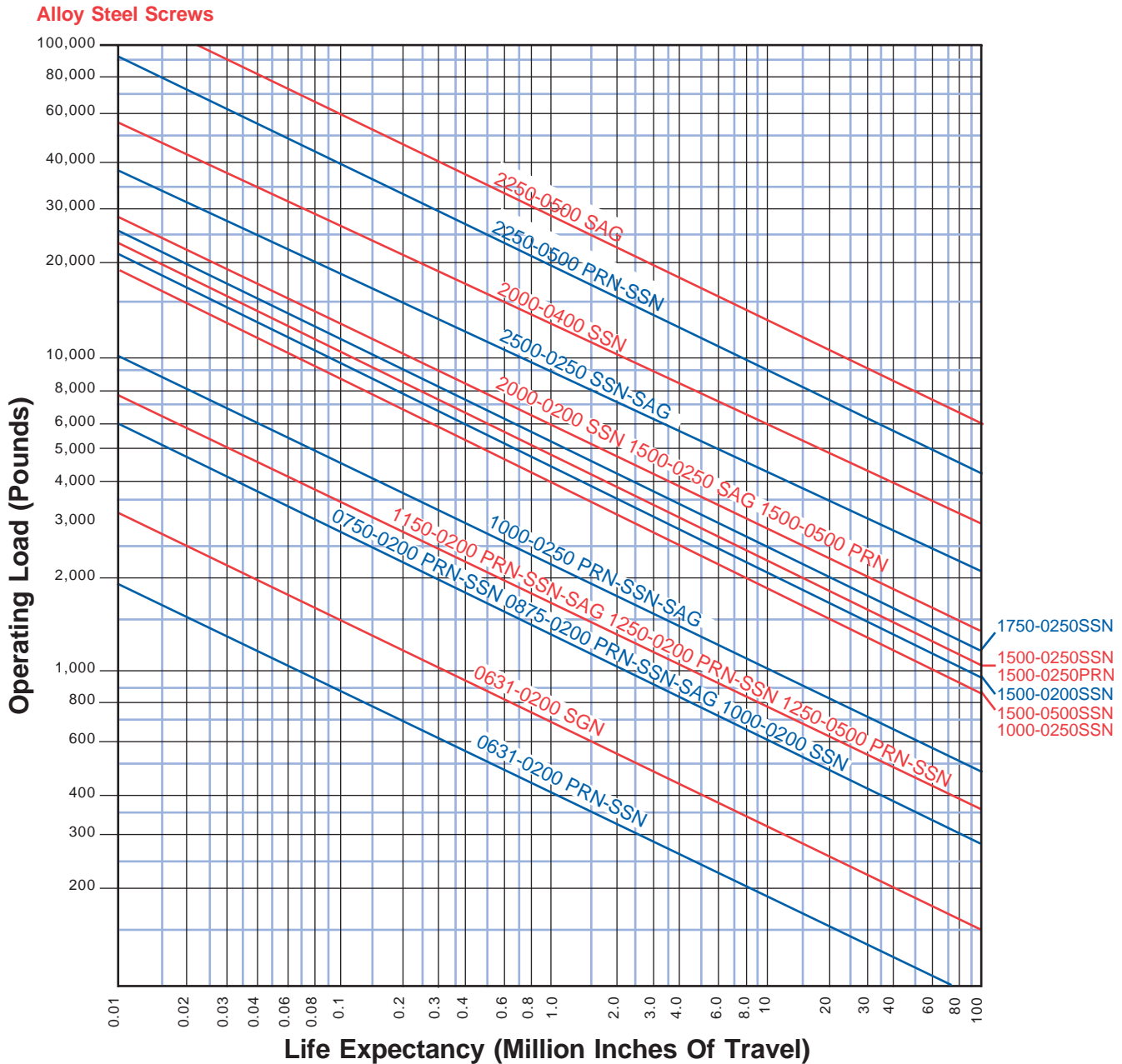

COLUMN STRENGTH: INCH SRT, XPR AND SGT SCREWS



Use this chart to verify the screw selected has sufficient column strength for your load.

TO USE THIS CHART: find a point at which the maximum length between bearing and load intersects the maximum load. Be sure the screw selected is above and to the right of that point.

PRECISION BALL SCREW ASSEMBLY TECHNICAL INTRODUCTION

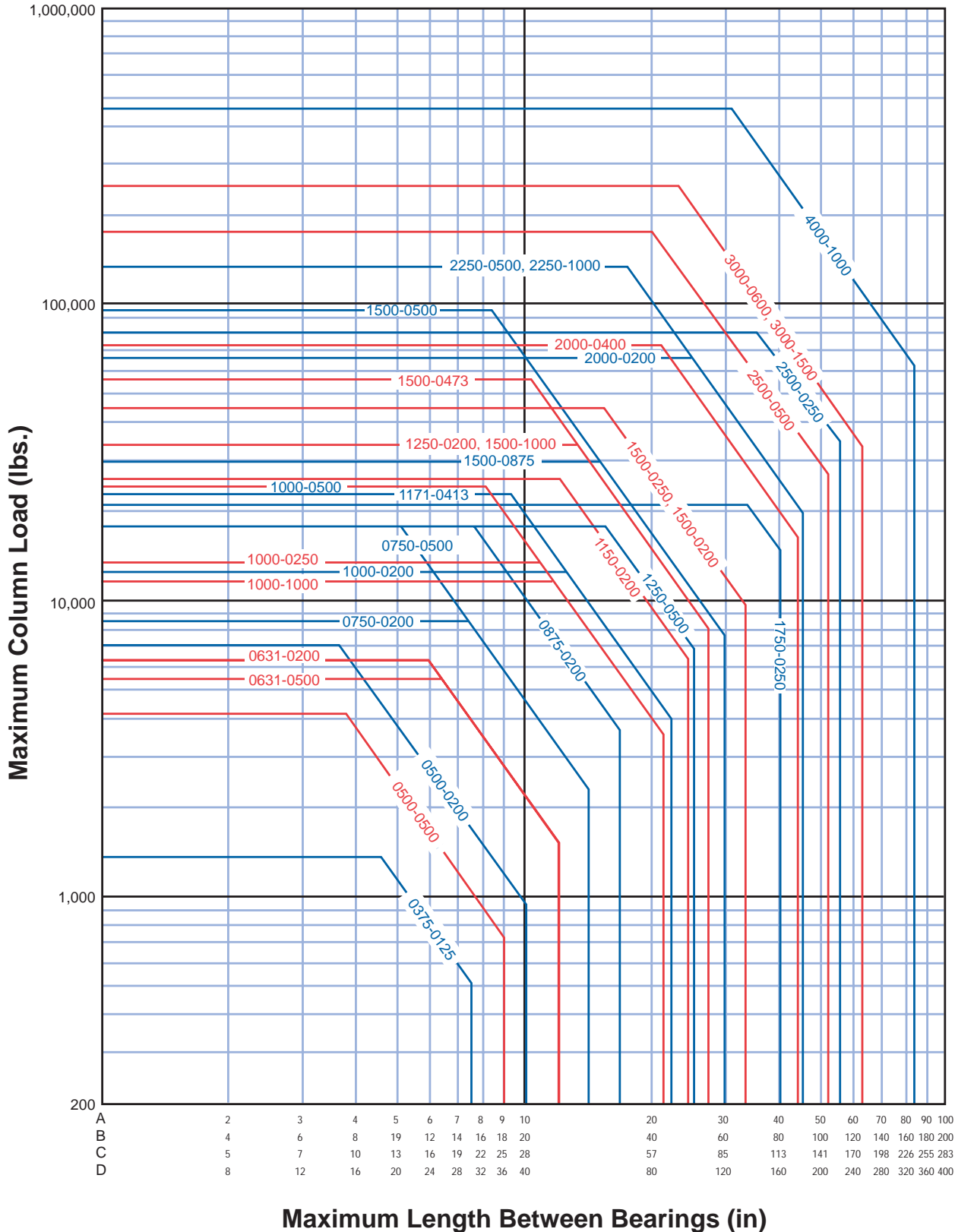

See Page 87 for Reference Description for "A-B-C-D" end fixity.

Maximum Length Between Bearings (in)

TO USE THIS CHART:

- 1) Determine maximum travel rate required.
- 2) Determine screw length "L".
- 3) Find point at which travel rate and screw length intersect.
Select a screw above and to the right of that point.

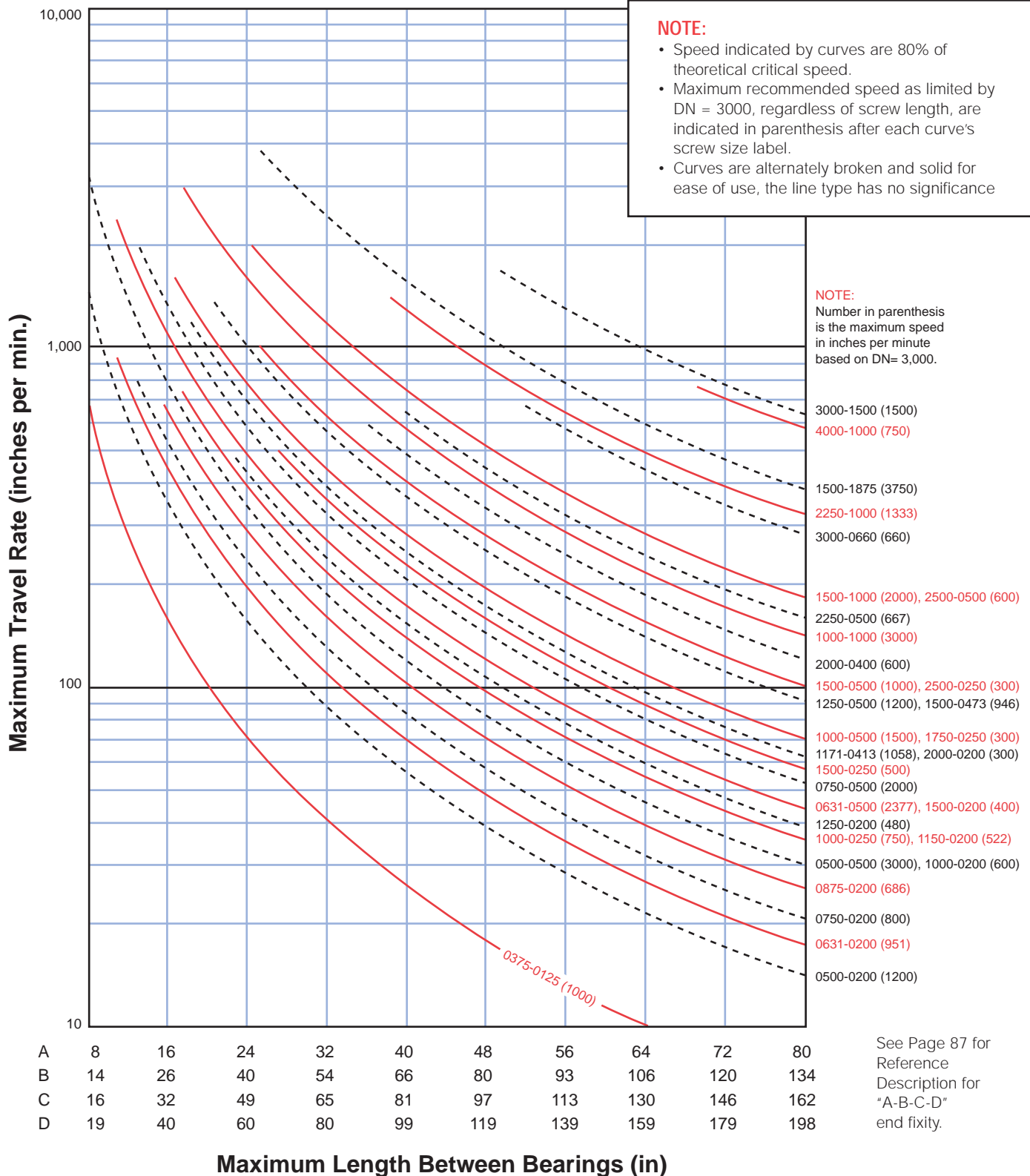

See Page 87 for
Reference
Description for
"A-B-C-D"
end fixity.



SRT, XPR and SGT BALL SCREWS

All ball screws are manufactured under controlled rolling or grinding processes. Heat treatment is controlled to guarantee consistent high quality.

PowerTrac™ SRT rolled alloy or stainless steel ball screw assemblies feature ± 0.004 "/ft lead accuracy.

PowerTrac™ XPR precision rolled ball screw assemblies feature ± 0.001 "/ft lead accuracy.

PowerTrac™ SGT precision ground ball screw assemblies feature ± 0.0005 "/ft lead accuracy.

<p>SBN for SRT</p>	<p>SGN Standard Ground Nut for SRT, XPR and SGT with V Thread</p>	<p>SEL Preload for SRT V Thread and Wipers</p>	<p>SAR Adjustable Preload for SRT with Integral Flange and Wipers</p>	<p>SAG Adjustable Preload for SGT with Integral Flange and Wipers</p>	<p>PRN Internal Preload for XPR/SGT V Thread and Wipers</p>	<p>SSN Internal Preload for XPR/SGT with Integral Flange and Wipers</p>
<p>Internal Return</p>						

SRT, XPR and SGT BALL NUTS

SBN Standard Ball Nut (no preload) for SRT screw – offer durable, low cost linear motion. Mounting flanges and wiper kits can be installed on the SBN nuts.

SGN Standard Ground Nut (“V” thread, no preload) for SRT, XPR or SGT Screw – are similar to SBN style ball nuts and have internal threads that are ground into the ball nut body. These nuts provide smooth, precise operation on rolled thread or ground thread ball screws.

SEL Standard Easy-Loc Adjustable Preload Ball Nut for SRT Screw – designed to eliminate the axial play or movement associated with standard ball nuts. Mounting flanges and wiper kits can be installed on the SEL nuts.

SAR Standard Adjustable Preload Ball Nut (Ground Ball Groove, Integral Flange & Wipers) for SRT Screw – offer the same high performance features found in precision ground thread ball nut assemblies with the added ability to run on rolled thread or ground thread screws. The SAR ball nut features adjustable preload, ground ball races, integral flange and wipers. The precision ground flange assures alignment of the nut preventing unnecessary wear.

SAG Standard Adjustable Preload Ball Nut (Ground Ball Groove, Integral Flange and Wipers) for SGT Screw – offer the precision tolerances of ground ball screw systems with the flexibility of adjustable preload.

PRN Standard Internal Preload Nut (“V” thread end with wipers) for XPR or SGT Screws – has a preload that is created by shifted internal threads that are ground in a single set-up. The resulting concentricity assures uniform preload. The PRN ball nuts are compact and stiff due to the single nut integral preload configuration. Factory fitting on ball screws provides a backlash-free system with uniform torque, high stiffness and long life.

SSN Standard Internal Preload Nut (Integral flange and wipers) for XPR or SGT Screws – have the same features as the PRN nut design while incorporating an integral flange.

E-900 IS A SPECIALIZED LUBRICANT FOR LINEAR APPLICATIONS THAT HAS BEEN PROVEN IN USE FOR OVER TWENTY-FIVE YEARS.

PROTECTS AGAINST INTER-BALL FRICTION, WEAR AND CORROSION

E-900 Ball Screw Lubricant may be used on rolled and ground thread ball screws. E-900 will provide a lasting film for wear protection and resistance to corrosion. With an operating range of -65° to +375°F, E-900 has low starting torque characteristics and helps reduce inter-ball friction in ball screw assemblies.

For optimum results the ball screw should be in good repair and free of dirt and grease. Used regularly E-900 will extend the life of ball screw assemblies. It should be applied generously on the entire length of the screw.

In addition, E-900 will prolong the useful life of ball bearing splines, bearings, anti-friction bearings, and other rolling element products.



LUBRICATION FOR PRECISION BALL SCREW ASSEMBLIES

E-900 SPRAY CAN	
PART NAME	E-900
NET CONTENTS PER UNIT	12 oz.
PART # NLU-1003	1 CAN weight of 1 lb.
PART # NLU-2003	1 CASE with 12 cans total weight of 13 lbs.

E-900 LIQUID	
PART NAME	E-900L
NET CONTENTS PER UNIT	32 oz.
PART # NLU-1004	1 BOTTLE weight of 32 oz.
PART # NLU-2004	1 CASE with 12 Quarts total weight of 25 lbs. 5 oz.



These definitions/descriptions are for the Product Specifications listed on the ball screw pages. Additional technical information on the preceding pages are designed to help you in selecting a ball screw and nut

that is best for your application. For additional assistance please contact our Application Engineers at 800-321-7800.

INCH BALL SCREW AND NUT TECHNICAL DATA

0631-0200 SRT

LEAD ACCURACY: ±0.004 in./ft.

Single Start	
0.631	Ball Circle Diameter
0.200	Lead
0.500	Root Diameter
0.125	Nominal Ball Diameter
0.82	Screw Weight (lbs./ft.)

Lead Accuracy Measured in inch/foot or μm/300mm. See page 94 for additional screw lead accuracy specifications.

Starts The integral number of helical thread elements on the screw shaft.

Ball Circle Diameter The diameter of the circle generated by the center of the bearing balls.

Lead The distance the nut advances in one revolution (lead = pitch x number of starts).

Root Diameter The diameter of the screw at the bottom of the thread groove.

Nominal Ball Diameter The approximate diameter of the load carrying balls contained in the ball nut.

Screw Weight/Mass Measured in lbs/ft for inch screws and in g/m for metric screws.

Ball Nut Style Heading The style of nut is identified in the drawing heading, refer to page 94 for additional nut style description.

Load Capacity Measured in lbs. or kN, this is the dynamic and static load rating of the nut.

Torque To Raise A linearly scalable value measured by in.-lb./lb. or N-m/kN. This is the torque required to keep one pound or one kN of load in motion.

Ball Nut Weight, Ball Nut, Flange and Wiper Kit Part Numbers Wiper Kits are available for most nuts.

Spring Rate/Preload Range Nuts which feature a preload have the spring rate or preload range listed. See page 94 for additional description for preload ball nuts.

Wiper Type Some nuts include integral wipers which are either Elastomer, Felt or Brush

Ball Quantity Ball quantity and size are nominal and may vary per nut.

Ball Nut Threads/Materials

All screws have an alloy steel right hand threaded nut and many sizes have an alloy steel left hand threaded and a stainless steel right hand threaded nut.

SBN Single Circuit Ball Nut

68 bearing balls total per nut

PRODUCT SPECIFICATIONS	RH	LH	RHSS	
Dynamic Load (lbs.)	815	815	—	1.200 DIA
Static Load (lbs.)	6,384	6,384	—	
Torque to Raise 1 lb. (in.-lb.)	.035	.035	—	
Nut Weight (lbs.)	.27	.27	—	
Ball Nut Number	SBN0827	SBN0828	—	
Flange Part Number	FLG7570	FLG7570	—	
Wiper Kit Part Number	WKB2647	WKB2647	—	

PRN Preloaded Ball Nut with Wipers

PRODUCT SPECIFICATIONS	RH	
Dynamic Load (lbs.)	440	
Static Load (lbs.)	2,110	
Torque to Raise 1 lb. (in.-lb.)	.035	
Spring Rate x 10 ⁶ (lb./in.)	1.6	
Nut Weight (lbs.)	.98	
Ball Nut Number	PRN10108	
Flange Part Number	—	
Wiper Type	ELASTOMER	

Standard Screw Threads, Materials and Lengths All screws are available in alloy steel with right hand threads. Many sizes are also available with left hand threads or in stainless steel with right hand threads.

Standard cut lengths are available for each screw size, custom cut screws up to 288" are available. Custom Screws over 288" can be manufactured based on material availability. See the Reference Number Configurator on page 98 for additional explanation on specifying a custom length screw.

Standard rolled screw length part number product or unmachined cut to length material may have approximately one inch of lead in taper on one or both ends, ground screws up to 3" unthreaded portion.

Standard Screw Lengths	PART NUMBERS		
	RH	LH	RHSS
2 FT.	SRT9392	SRT9562	SRT5359
4 FT.	SRT9987	SRT5092	SRT5648
6 FT.	SRT7540	SRT7541	SRT5378

Custom cut lengths available up to 24' for alloy, up to 12' for stainless.
For longer lengths contact Customer Service.

Flanges are made of black oxidized steel. Flanges are manufactured to be pinned to the ball nut. See page 83 for additional pinning information.

Flange - FLG7574

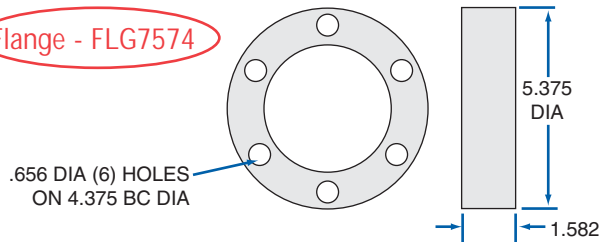

Wiper Kits Felt or brush wiper kits are available for most ball nuts.

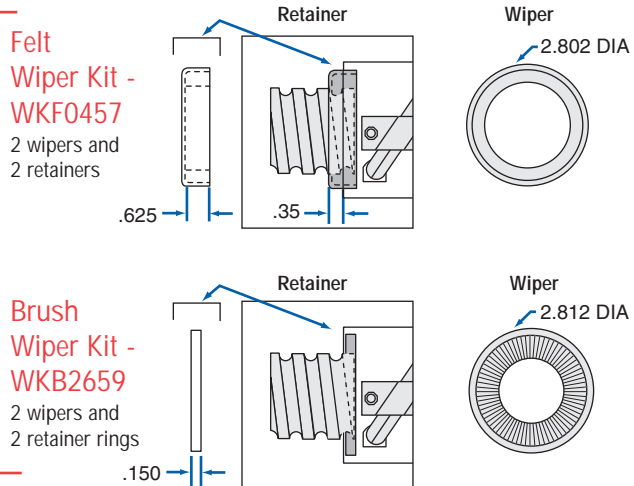

1000-0250 SRT RH / EK / 4N / 41.87 / SBN7508 / FS

INCH BALL SCREW AND NUT TECHNICAL DATA

BALL SCREW

Thread Form Codes

Part#	Dia. - Lead	Part#	Dia. - Lead
0375-0125	= 0.375-0.125	1500-0200	= 1.500-0.200
0500-0200	= 0.500-0.200	1500-0250	= 1.500-0.250
0500-0500	= 0.500-0.500	1500-0473	= 1.500-0.473
0631-0200	= 0.631-0.200	1500-0500	= 1.500-0.500
0631-0500	= 0.631-0.500	1500-1000	= 1.500-1.000
0750-0200	= 0.750-0.200	1500-1875	= 1.500-0.875
0750-0500	= 0.750-0.500	1750-0250	= 1.750-0.250
0875-0200	= 0.875-0.200	2000-0200	= 2.000-0.200
1000-0200	= 1.000-0.200	2000-0400	= 2.000-0.400
1000-0250	= 1.000-0.250	2250-0500	= 2.250-0.500
1000-0500	= 1.000-0.500	2250-1000	= 2.250-1.000
1000-1000	= 1.000-1.000	2500-0250	= 2.500-0.250
1150-0200	= 1.150-0.200	2500-0500	= 2.500-0.500
1171-0413	= 1.171-0.413	3000-0660	= 3.000-0.660
1250-0200	= 1.250-0.200	3000-1500	= 3.000-1.500
1250-0500	= 1.250-0.500	4000-1000	= 4.000-1.000

PRECISION

SRT = Standard Rolled Thread ±0.004"/ft.
XPR = Precision Rolled Thread ±0.001"/ft.
SGT = Precision ground Thread ±0.0005"/ft.

NOTE:
Not all precisions are available for all sizes.

MATERIAL

RH = Right Hand Thread SS = Stainless Steel
LH = Left Hand Thread

NOTE:
Not all materials/threads are available for all sizes.

FIRST END CONFIGURATION

EZZE-MOUNT™ / End Machining
(see page 214 & 212)

- 1 = Type 1 3 = Type 3
- 2 = Type 2 4 = Type 4

B = Universal Double Bearing Support End Cap Facing Screw Thread

C = Universal Single Bearing Support

D = Flanged Single Bearing Support Flange Facing Screw Thread

E = Universal Double Bearing Support End Cap Facing Away From Screw Thread

F = Flanged Double Bearing Support Flange Facing Screw Thread

G = Flanged Single Bearing Support Flange Facing Away From Screw Thread

H = Flanged Double Bearing Support Flange Facing Away From Screw Thread

U = Universal Double Bearing Support with Motor Mount (see page 217)

Y = Flanged Double Bearing Support with Motor Mount (see page 218)

00 = No End Machining (Screw will be cut to desired length).

XX = Custom Machining (Print or specified data must be provided).

EK

EK = Universal Double Bearing Support, with Keyway

Shaft Extension
(see page 212)

- K** = Shaft Extension with Keyway
- L** = Shaft Extension without Keyway
- Q** = HandWheel
- N** = No Shaft Extension

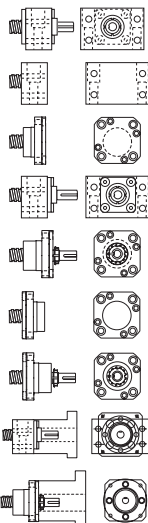

NOTE: Both Ends must be specified.

Single Bearing Supports are used in conjunction with Type 1N end machining.

Double Bearing Supports are used in conjunction with Type 3K, 3L, or 3N end machining.

SECOND END CONFIGURATION

Refer to the First End Configuration section above.

NOTE: Both Ends must be specified.

OVER - ALL - LENGTH (OAL)

Length in inches, 2 place decimal

BALL NUT

Nut will be installed with flange or threaded end toward first end designation. 00000 = No Nut

MODIFIER LIST

F, B, and/or W Optional
F = Round Flange **B** = Boot
W = Wiper

S or M Required
S = Standard, no additional description required
M = Modified, additional description required

Standard Screw Lengths	PART NUMBERS		
	RH	LH	RHSS
2 FT.	SRT9420	SRT8528	SRT6536
4 FT.	SRT7538	SRT8532	SRT6540

Custom cut lengths available up to 12'. For longer lengths contact Customer Service.

0375-0125 SRT

LEAD ACCURACY: ±0.004 in./ft.

Single Start

- 0.375** Ball Circle Diameter
- 0.125** Lead
- 0.300** Root Diameter
- 0.0625** Nominal Ball Diameter
- 0.31** Screw Weight (lbs./ft.)

SBN Single Circuit Ball Nut				60 bearing balls total per nut
PRODUCT SPECIFICATIONS	RH	LH	RHSS	
Dynamic Load (lbs.)	136	136	24	
Static Load (lbs.)	1,415	1,415	255	
Torque to Raise 1 lb. (in.-lb.)	.022	.022	.022	
Nut Weight (lbs.)	.13	.13	.13	
Ball Nut Number	SBN9574	SBN9576	SBN9578	
Flange Part Number	FLG6751	FLG6751	—	
Wiper Kit Part Number	—	—	—	

SBN Double Circuit Ball Nut				60 bearing balls per circuit - 120 total per nut
PRODUCT SPECIFICATIONS	RH	LH	RHSS	
Dynamic Load (lbs.)	272	272	50	
Static Load (lbs.)	2,830	2,830	509	
Torque to Raise 1 lb. (in.-lb.)	.022	.022	.022	
Nut Weight (lbs.)	.21	.21	.21	
Ball Nut Number	SBN7502	SBN8282	SBN7643	
Flange Part Number	FLG6751	FLG6751	—	
Wiper Kit Part Number	—	—	—	

SEL Preload Ball Nut				60 bearing balls per circuit - 120 total per nut
PRODUCT SPECIFICATIONS	RH	LH	RHSS	
Dynamic Load (lbs.)	136	—	—	
Static Load (lbs.)	1,415	—	—	
Torque to Raise 1 lb. (in.-lb.)	.022	—	—	
Preload (lbs.)	10	—	—	
Nut Weight (lbs.)	.21	—	—	
Ball Nut Number	SEL0375	—	—	
Flange Part Number	FLG6751	—	—	
Wiper Kit Part Number	—	—	—	

Flange - FLG6751

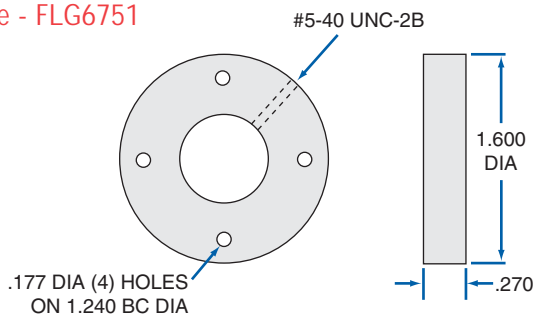

TWIN-LEAD SCREW

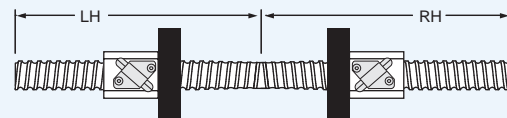

See page 148 for complete product details.

EZZE-MOUNT™ END BEARING SUPPORTS

A convenient solution for mounting ball screw assemblies.



Single or Double Bearing Universal Mount Single or Double Bearing Flange Mount

See page 214 for complete product details.

0500-0200 SRT

LEAD ACCURACY: ±0.004 in./ft.

Single Start

- 0.500** Ball Circle Diameter
- 0.200** Lead
- 0.405** Root Diameter
- 0.125** Nominal Ball Diameter
- 0.50** Screw Weight (lbs./ft.)

Standard Screw Lengths	PART NUMBERS
	RH
2 FT.	SRT5224
4 FT.	SRT5248
6 FT.	SRT5272

Custom cut lengths available up to 12'. For longer lengths contact Customer Service.

INCH BALL SCREW AND NUT TECHNICAL DATA

SBN Double Circuit Ball Nut		40 bearing balls per circuit - 80 total per nut
PRODUCT SPECIFICATIONS	RH	
Dynamic Load (lbs.)	973	
Static Load (lbs.)	7,071	
Torque to Raise 1 lb. (in.-lb.)	.035	
Nut Weight (lbs.)	.51	
Ball Nut Number	SBN10094	
Flange Part Number	FLG7570	
Wiper Kit Part Number	—	

SEL Adjustable Preload Ball Nut		40 bearing balls per circuit - 160 total per nut
PRODUCT SPECIFICATIONS	RH	
Dynamic Load (lbs.)	973	
Static Load (lbs.)	7,071	
Torque to Raise 1 lb. (in.-lb.)	.035	
Preload Range (lbs.)	97-292	
Nut Weight (lbs.)	1.1	
Ball Nut Number	SEL10103	
Flange Part Number	FLG7570	
Wiper Kit Part Number	—	

Flange - FLG7570

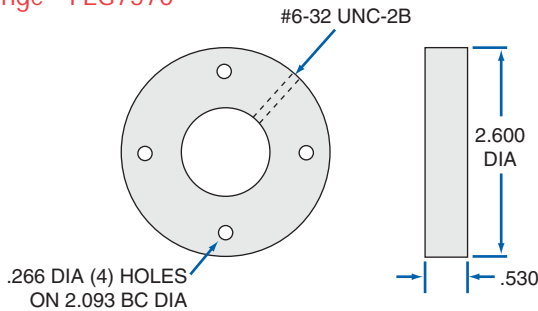

BALL SCREW ASSEMBLIES

These assemblies are shipped with screw, nut, flange, and bearing supports.

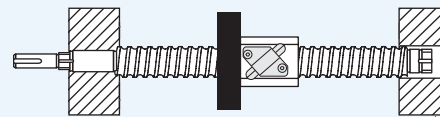

See page 145 for complete product details.

EZZE-MOUNT™ END BEARING SUPPORTS

A convenient solution for mounting ball screw assemblies.

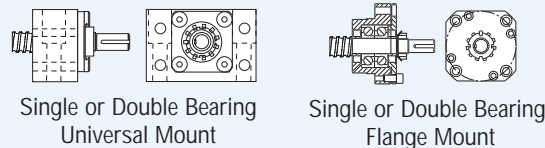

See page 214 for complete product details.

LUBRICANT

Prolong ball screw and nut performance with this special lubricant.

E-900 12oz. Spray or 32oz. Liquid
See page 95 for complete product details.



Standard Screw Lengths	PART NUMBERS	
	RH	RHSS
2 FT.	SRT6736	SRT6700
4 FT.	SRT6740	SRT6704
6 FT.	SRT6744	SRT6846

Custom cut lengths available up to 24' for alloy, up to 12' for stainless.
For longer lengths contact Customer Service.

0500-0500 SRT

LEAD ACCURACY: ±0.004 in./ft.

Double Start

- 0.500** Ball Circle Diameter
- 0.500** Lead
- 0.360** Root Diameter
- 0.125** Nominal Ball Diameter
- 0.50** Screw Weight (lbs./ft.)

SBN Double Circuit Ball Nut			30 bearing balls per circuit - 60 total per nut
PRODUCT SPECIFICATIONS	RH	RH Nickel Plated	
Dynamic Load (lbs.)	786	786/141*	
Static Load (lbs.)	4,131	4,131/744*	
Torque to Raise 1 lb. (in.-lb.)	.088	.088	
Nut Weight (lbs.)	.27	.27	
Ball Nut Number	SBN9582	SBN9582E	
Flange Part Number	FLG7570	FLG7570	
Wiper Kit Part Number	—	—	

*Load rating for stainless steel screw

SBN Double Circuit Ball Nut		30 bearing balls per circuit - 60 total per nut
PRODUCT SPECIFICATIONS	RH	
Dynamic Load (lbs.)	786	
Static Load (lbs.)	4,131	
Torque to Raise 1 lb. (in.-lb.)	.088	
Nut Weight (lbs.)	.26	
Ball Nut Number	SBN7506	
Flange Part Number	—	
Wiper Kit Part Number	—	

Flange - FLG7570

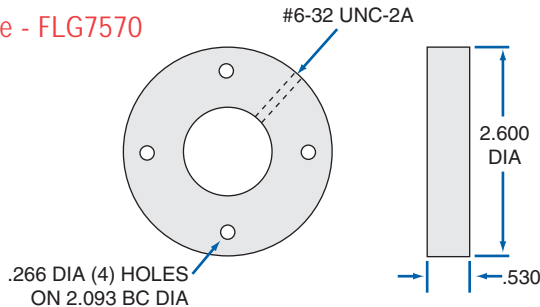

BALL SCREW ASSEMBLIES

These assemblies are shipped with screw, nut, flange, and bearing supports.

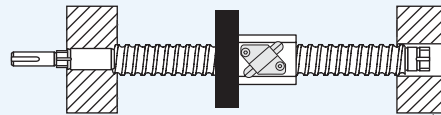

See page 145 for complete product details.

EZZE-MOUNT™ END BEARING SUPPORTS

A convenient solution for mounting ball screw assemblies.

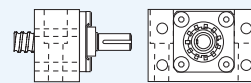

Single or Double Bearing
Universal Mount

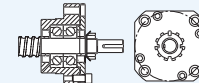

Single or Double Bearing
Flange Mount

See page 214 for complete product details.



LUBRICANT

Prolong ball screw and nut performance with this special lubricant.

E-900 12oz. Spray or 32oz. Liquid
See page 95 for complete product details.



0631-0200 SRT

LEAD ACCURACY: ±0.004 in./ft.

Single Start

- 0.631** Ball Circle Diameter
- 0.200** Lead
- 0.500** Root Diameter
- 0.125** Nominal Ball Diameter
- 0.82** Screw Weight (lbs./ft.)

Standard Screw Lengths	PART NUMBERS		
	RH	LH	RHSS
2 FT.	SRT9392	SRT9562	SRT5359
4 FT.	SRT9987	SRT5092	SRT5648
6 FT.	SRT7540	SRT7541	SRT5378

Custom cut lengths available up to 24' for alloy, up to 12' for stainless.
For longer lengths contact Customer Service.

INCH BALL SCREW AND NUT TECHNICAL DATA

SBN Single Circuit Ball Nut				68 bearing balls total per nut
PRODUCT SPECIFICATIONS	RH	LH	RHSS	
Dynamic Load (lbs.)	—	—	140	
Static Load (lbs.)	—	—	1,149	
Torque to Raise 1 lb. (in.-lb.)	—	—	.035	
Nut Weight (lbs.)	—	—	.27	
Ball Nut Number	—	—	SBN7645	
Flange Part Number	—	—	—	
Wiper Kit Part Number	—	—	—	

SBN Single Circuit Ball Nut with Wrench Flats				68 bearing balls total per nut
PRODUCT SPECIFICATIONS	RH	LH	RHSS	
Dynamic Load (lbs.)	815	815	—	
Static Load (lbs.)	6,384	6,384	—	
Torque to Raise 1 lb. (in.-lb.)	.035	.035	—	
Nut Weight (lbs.)	.27	.27	—	
Ball Nut Number	SBN10325	SBN10409	—	
Flange Part Number	FLG7570	FLG7570	—	
Wiper Kit Part Number	WKB10407	WKB10407	—	

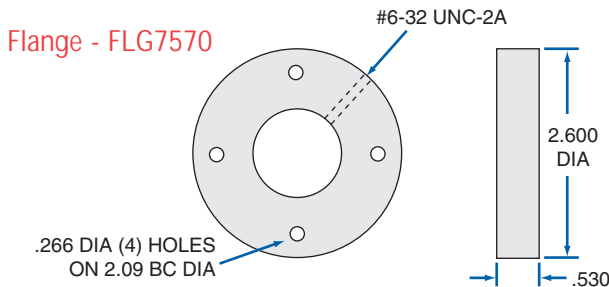

Brush Wiper Kit - WKB2647
2 wipers and 1 retainer

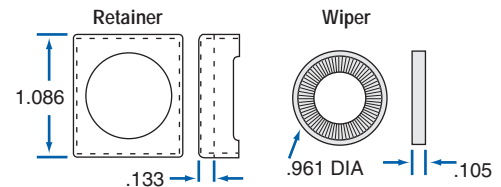

Brush Wiper Kit - WKB10407
2 wipers and 1 retainer

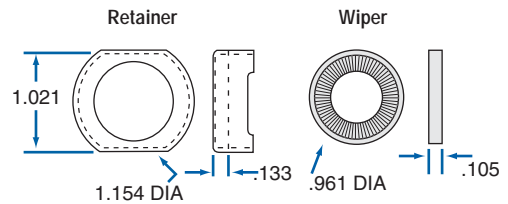

Standard Screw Lengths	PART NUMBERS		
	RH	LH	RHSS
2 FT.	SRT9392	SRT9562	SRT5359
4 FT.	SRT9987	SRT5092	SRT5648
6 FT.	SRT7540	SRT7541	SRT5378
Custom cut lengths available up to 24' for alloy, up to 12' for stainless. For longer lengths contact Customer Service.			

0631-0200 SRT continued

LEAD ACCURACY: ±0.004 in./ft.

Single Start

- 0.631** Ball Circle Diameter
- 0.200** Lead
- 0.500** Root Diameter
- 0.125** Nominal Ball Diameter
- 0.82** Screw Weight (lbs./ft.)

SBN Internal Return Ball Nut				64 bearing balls total per nut
PRODUCT SPECIFICATIONS	RH	LH	RHSS	
Dynamic Load (lbs.)	712	712	—	
Static Load (lbs.)	5,250	5,250	—	
Torque to Raise 1 lb. (in.-lb.)	.035	.035	—	
Nut Weight (lbs.)	.27	.27	—	
Ball Nut Number	SBN10263	SBN10264	—	
Flange Part Number	FLG7570	FLG7570	—	
Wiper Kit Part Number	—	—	—	

SEL Adjustable Preload Ball Nut with Wrench Flats				68 bearing balls per circuit - 136 total per nut
PRODUCT SPECIFICATIONS	RH	LH	RHSS	
Dynamic Load (lbs.)	815	815	—	
Static Load (lbs.)	6,384	6,384	—	
Torque to Raise 1 lb. (in.-lb.)	.035	.035	—	
Preload Range (lbs.)	78-233	78-233	—	
Nut Weight (lbs.)	.65	.65	—	
Ball Nut Number	SEL10408	SEL10410	—	
Flange Part Number	FLG7570	FLG7570	—	
Wiper Kit Part Number	WKB10407	WKB10407	—	

BALL SCREW ASSEMBLIES

These assemblies are shipped with screw, nut, flange, and bearing supports.

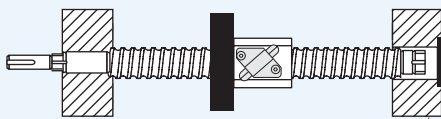

See page 145 for complete product details.

EZZE-MOUNT™ END BEARING SUPPORTS

A convenient solution for mounting ball screw assemblies.

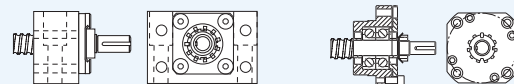

Single or Double Bearing
Universal Mount

Single or Double Bearing
Flange Mount

See page 214 for complete product details.

TWIN-LEAD SCREW

Single piece twin-lead screws offer opposing motion through a single drive system.

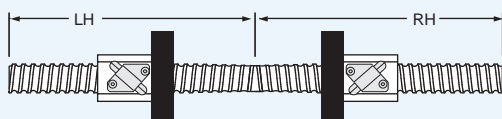

See page 148 for complete product details.

LUBRICANT

Prolong ball screw and nut performance with this special lubricant.



E-900 12oz. Spray or 32oz. Liquid
See page 95 for complete product details.

0631-0200 XPR and SGT

LEAD ACCURACY: XPR ± 0.001 in./ft. SGT ± 0.0005 in./ft.

Single Start

- 0.631** Ball Circle Diameter
- 0.200** Lead
- 0.500** Root Diameter
- 0.125** Nominal Ball Diameter
- 0.86** Screw Weight (lbs./ft.)

Standard Screw Lengths	PART NUMBERS		
	XPR RH	SGT RH	SGT LH
4 FT.	XPR6320R48	GT06320R48	GT06320L48
6 FT.	XPR6320R72	—	—

XPR custom cut lengths available up to 12',
SGT custom cut lengths available up to 6', contact Customer Service.

INCH BALL SCREW AND NUT TECHNICAL DATA

PRN Preloaded Ball Nut with Wipers

30 bearing balls per circuit - 60 total per nut

PRODUCT SPECIFICATIONS	RH
Dynamic Load (lbs.)	440
Static Load (lbs.)	2,110
Torque to Raise 1 lb. (in.-lb.)	.035
Spring Rate x 10 ⁶ (lb./in.)	1.6
Nut Weight (lbs.)	.98
Ball Nut Number	PRN10108
Flange Part Number	FLG7555
Wiper Type	ELASTOMER

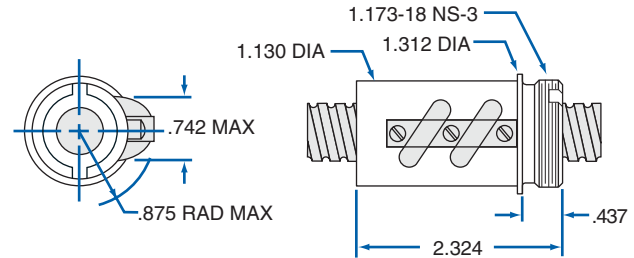

SGN Ball Nut

30 bearing balls per circuit - 60 total per nut

PRODUCT SPECIFICATIONS	RH	LH
Dynamic Load (lbs.)	700	700
Static Load (lbs.)	3,360	3,360
Torque to Raise 1 lb. (in.-lb.)	.035	.035
Nut Weight (lbs.)	.80	.80
Ball Nut Number	SGN10083	SGN10253
Flange Part Number	FLG7570	FLG7570
Wiper Kit Part Number	—	—

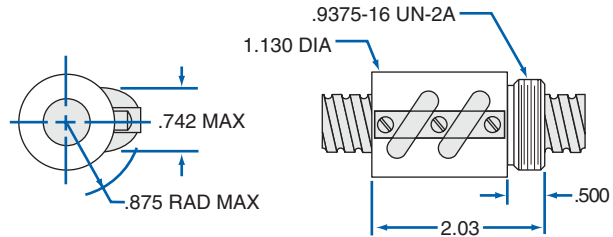

PRN Preloaded Ball Nut

30 bearing balls per circuit - 60 total per nut

PRODUCT SPECIFICATIONS	RH
Dynamic Load (lbs.)	350
Static Load (lbs.)	1,680
Torque to Raise 1 lb. (in.-lb.)	.035
Spring Rate x 10 ⁶ (lb./in.)	1.0
Nut Weight (lbs.)	.80
Ball Nut Number	PRN10106
Flange Part Number	FLG7570
Wiper Kit Part Number	—

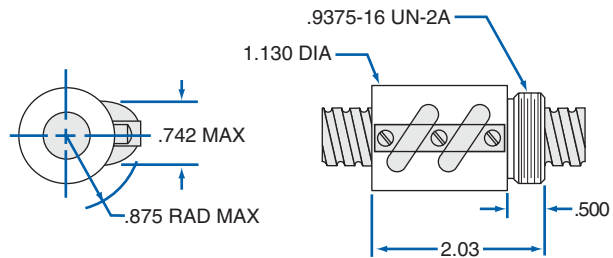

SSN Preloaded Flanged Ball Nut with Wipers

30 bearing balls per circuit - 60 total per nut

PRODUCT SPECIFICATIONS	RH
Dynamic Load (lbs.)	440
Static Load (lbs.)	2,110
Torque to Raise 1 lb. (in.-lb.)	.035
Spring Rate x 10 ⁶ (lb./in.)	1.6
Nut Weight (lbs.)	1.2
Ball Nut Number	SSN0389
Flange	INTEGRAL
Wiper Type	ELASTOMER

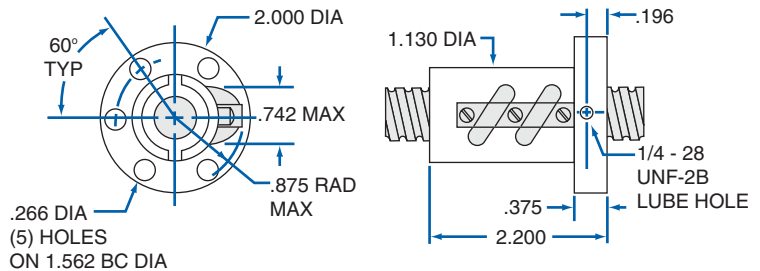

Standard Screw Lengths	PART NUMBERS	
	XPR RH	SGT RH
4 FT.	XPR6320R48	GT06320R48
6 FT.	XPR6320R72	—

XPR custom cut lengths available up to 12',
SGT custom cut lengths available up to 4', contact Customer Service.

0631-0200 XPR and SGT

LEAD ACCURACY: XPR ±0.001 in./ft. SGT ±0.0005 in./ft.

Single Start

- 0.631** Ball Circle Diameter
- 0.200** Lead
- 0.500** Root Diameter
- 0.125** Nominal Ball Diameter
- 0.86** Screw Weight (lbs./ft.)

SSN Preloaded Internal Return Ball Nut with Wipers 64 bearing balls total per nut

PRODUCT SPECIFICATIONS	RH
Dynamic Load (lbs.)	450
Static Load (lbs.)	2,115
Torque to Raise 1 lb. (in.-lb.)	.035
Spring Rate x 10 ⁶ (lb./in.)	1.5
Nut Weight (lbs.)	.27
Ball Nut Number	SSN10274
Flange Part Number	FLG7570
Wiper Type	ELASTOMER

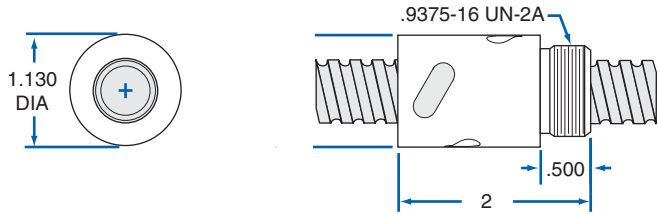

SSN Preloaded Flanged Internal Return Ball Nut with Wipers 64 bearing balls total per nut

PRODUCT SPECIFICATIONS	RH
Dynamic Load (lbs.)	450
Static Load (lbs.)	2,115
Torque to Raise 1 lb. (in.-lb.)	.035
Spring Rate x 10 ⁶ (lb./in.)	1.5
Nut Weight (lbs.)	.45
Ball Nut Number	SSN10304
Flange	INTEGRAL
Wiper Type	ELASTOMER

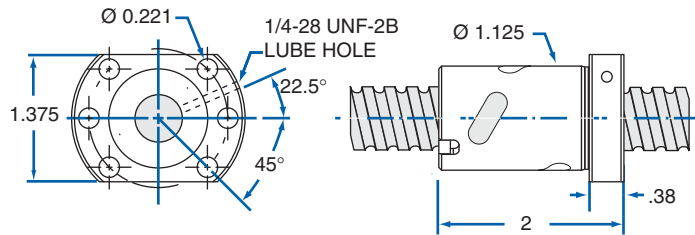

BALL SCREW ASSEMBLIES

These assemblies are shipped with screw, nut, flange, and bearing supports.

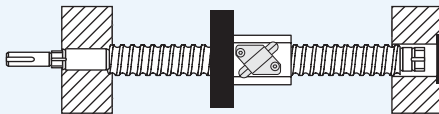

See page 145 for complete product details.

EZZE-MOUNT™ END BEARING SUPPORTS

A convenient solution for mounting ball screw assemblies.

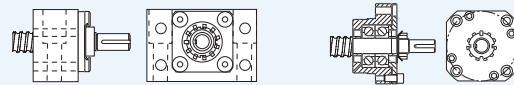

Single or Double Bearing
Universal Mount

Single or Double Bearing
Flange Mount

See page 214 for complete product details.

TWIN-LEAD SCREW

Single piece twin-lead screws offer opposing motion through a single drive system.

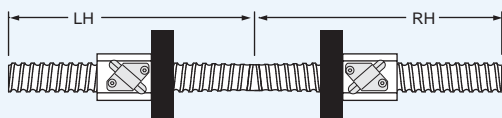

See page 148 for complete product details.

LUBRICANT

Prolong ball screw and nut performance with this special lubricant.



E-900 12oz. Spray or 32oz. Liquid
See page 95 for complete product details.



0631-0500 SRT

LEAD ACCURACY: ±0.004 in./ft.

Double Start

- 0.631** Ball Circle Diameter
- 0.500** Lead
- 0.500** Root Diameter
- 0.125** Nominal Ball Diameter
- 0.82** Screw Weight (lbs./ft.)

Standard Screw Lengths	PART NUMBERS
	RH
2 FT.	SRT6524
4 FT.	SRT6548
6 FT.	SRT6572

Custom cut lengths available up to 12'. For longer lengths contact Customer Service.

INCH BALL SCREW AND NUT TECHNICAL DATA

SBN Double Circuit Ball Nut

37 bearing balls per circuit - 74 total per nut

PRODUCT SPECIFICATIONS	RH
Dynamic Load (lbs.)	960
Static Load (lbs.)	5,565
Torque to Raise 1 lb. (in.-lb.)	.088
Nut Weight (lbs.)	.27
Ball Nut Number	SBN10113
Flange Part Number	FLG7570

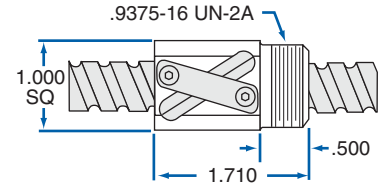
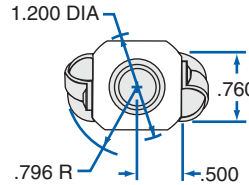

SEL Adjustable Preload Ball Nut

37 bearing balls per circuit - 148 total per nut

PRODUCT SPECIFICATIONS	RH
Dynamic Load (lbs.)	960
Static Load (lbs.)	5,565
Torque to Raise 1 lb. (in.-lb.)	.088
Preload Range (lbs.)	96-288
Nut Weight (lbs.)	.65
Ball Nut Number	SEL10182
Flange Part Number	FLG7570

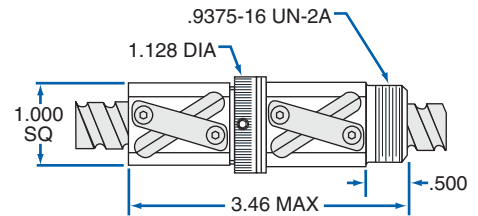
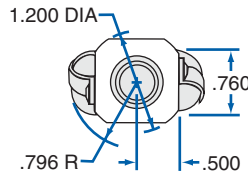

Flange - FLG7570

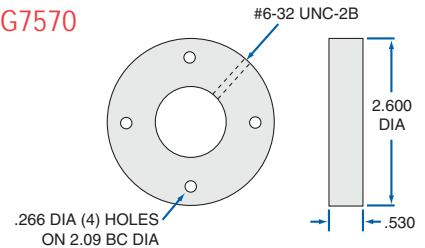

0631-1000 SRT

LEAD ACCURACY: ±0.004 in./ft.

Double Start

- 0.631** Ball Circle Diameter
- 0.500** Lead
- 1.000** Root Diameter
- 0.125** Nominal Ball Diameter
- 0.82** Screw Weight (lbs./ft.)

Standard Screw Lengths	PART NUMBERS
	RH
2 FT.	SRT6124
4 FT.	SRT6148
6 FT.	SRT6172

Custom cut lengths available up to 12'. For longer lengths contact Customer Service.

SBN Double Circuit Ball Nut

21 bearing balls per circuit - 42 total per nut

PRODUCT SPECIFICATIONS	RH
Dynamic Load (lbs.)	620
Static Load (lbs.)	2580
Torque to Raise 1 lb. (in.-lb.)	0.177
Nut Weight (lbs.)	0.28
Ball Nut Number	SBN10392*
Flange Part Number	FLG 7570

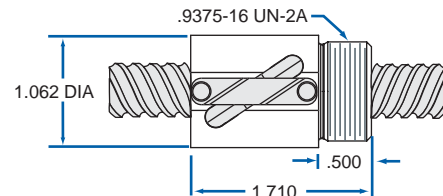
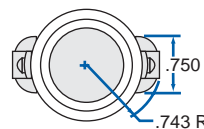

* High capacity 4 circuit available—consult engineers

Standard Screw Lengths	PART NUMBERS
	RH
4 FT.	SRT7248
8 FT.	SRT7296
12 FT.	SRT7244

Custom cut lengths available up to 24'. For longer lengths contact Customer Service.

0750-0200 SRT

LEAD ACCURACY: ±0.004 in./ft.

Single Start

- 0.750** Ball Circle Diameter
- 0.200** Lead
- 0.602** Root Diameter
- 0.141** Nominal Ball Diameter
- 1.22** Screw Weight (lbs./ft.)

SBN Single Circuit Ball Nut		70 bearing balls total per nut
PRODUCT SPECIFICATIONS	RH	
Dynamic Load (lbs.)	1,100	
Static Load (lbs.)	8,569	
Torque to Raise 1 lb. (in.-lb.)	.035	
Nut Weight (lbs.)	.5	
Ball Nut Number	SBN7201	
Flange Part Number	FLG7555	
Wiper Kit Part Number	WKB7200	

SBN Double Circuit Ball Nut		70 bearing balls per circuit - 140 total per nut
PRODUCT SPECIFICATIONS	RH	
Dynamic Load (lbs.)	2,200	
Static Load (lbs.)	17,138	
Torque to Raise 1 lb. (in.-lb.)	.035	
Nut Weight (lbs.)	.8	
Ball Nut Number	SBN7202	
Flange Part Number	FLG7555	
Wiper Kit Part Number	WKB7200	

SEL Adjustable Preload Ball Nut		70 bearing balls per circuit - 280 total per nut
PRODUCT SPECIFICATIONS	RH	
Dynamic Load (lbs.)	2,200	
Static Load (lbs.)	17,138	
Torque to Raise 1 lb. (in.-lb.)	.035	
Preload Range (lbs.)	220-660	
Nut Weight (lbs.)	2.1	
Ball Nut Number	SEL10057	
Flange Part Number	FLG7555	
Wiper Kit Part Number	WKB7200	

Flange - FLG7555

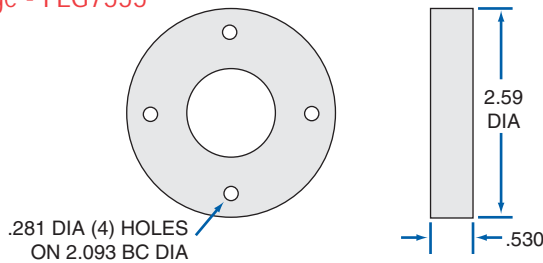

Brush Wiper Kit - WKB7200

2 wipers and
1 retainer

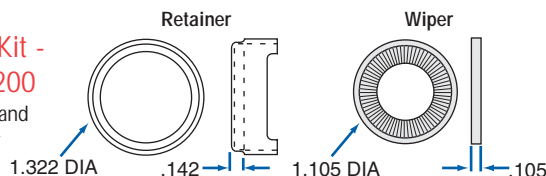

BALL SCREW ASSEMBLIES

These assemblies are shipped with screw, nut, flange, and bearing supports.

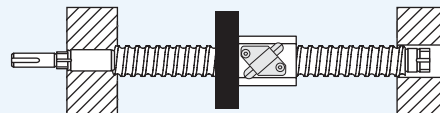

See page 145 for complete product details.

0750-0200 XPR and SGT

LEAD ACCURACY: XPR ± 0.001 in./ft. SGT ± 0.0005 in./ft.

Single Start

- 0.750** Ball Circle Diameter
- 0.200** Lead
- 0.602** Root Diameter
- 0.141** Nominal Ball Diameter
- 1.2** Screw Weight (lbs./ft.)

Standard Screw Lengths	PART NUMBERS	
	XPR RH	SGT RH
4 FT.	XPR7520R48	GT07520R48
8 FT.	XPR7520R96	—

XPR custom cut lengths available up to 12',
SGT custom cut lengths available up to 5', contact Customer Service.

INCH BALL SCREW AND NUT TECHNICAL DATA

PRN Preloaded Ball Nut with Wipers

71 bearing balls per circuit - 142 total per nut

PRODUCT SPECIFICATIONS	RH
Dynamic Load (lbs.)	1,473
Static Load (lbs.)	9,916
Torque to Raise 1 lb. (in.-lb.)	.035
Spring Rate x 10 ⁶ (lb./in.)	2.75
Nut Weight (lbs.)	1.0
Ball Nut Number	PRN10109
Flange Part Number	FLG8281
Wiper Type	ELASTOMER

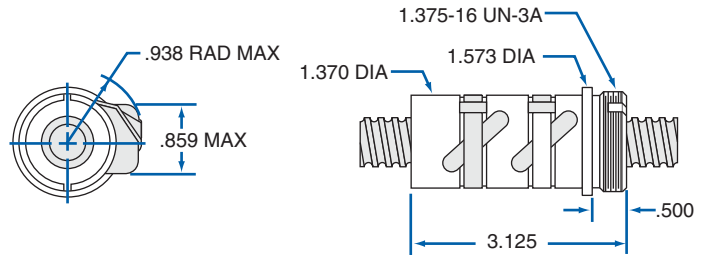

SSN Preloaded Flanged Ball Nut with Wipers

71 bearing balls per circuit - 142 total per nut

PRODUCT SPECIFICATIONS	RH
Dynamic Load (lbs.)	1,473
Static Load (lbs.)	9,916
Torque to Raise 1 lb. (in.-lb.)	.035
Spring Rate x 10 ⁶ (lb./in.)	2.75
Nut Weight (lbs.)	1.2
Ball Nut Number	SSN0390
Flange	INTEGRAL
Wiper Type	ELASTOMER

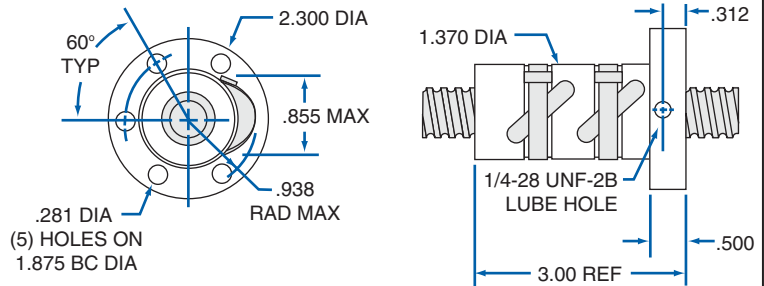

BALL SCREW ASSEMBLIES

These assemblies are shipped with screw, nut, flange, and bearing supports.

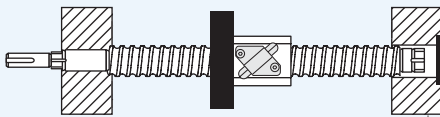

See page 145 for complete product details.

EZZE-MOUNT™

END BEARING SUPPORTS

A convenient solution for mounting ball screw assemblies.

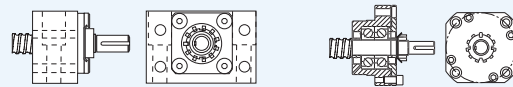

Single or Double Bearing
Universal Mount

Single or Double Bearing
Flange Mount

See page 214 for complete product details.

END MACHINING

Machining for Nook standard ends or custom requirement available.

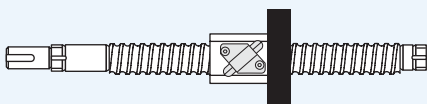

See page 212 for complete product details.

LUBRICANT

Prolong ball screw and nut performance with this special lubricant.



E-900 12oz. Spray or 32oz. Liquid
See page 95 for complete product details.

Standard Screw Lengths	PART NUMBERS	
	RH	
4 FT.	SRT7552	
8 FT.	SRT7596	
12 FT.	SRT7292	

Custom cut lengths available up to 24'. For longer lengths contact Customer Service.

0750-0500 SRT

LEAD ACCURACY: ±0.004 in./ft.

Double Start

- 0.750** Ball Circle Diameter
- 0.500** Lead
- 0.602** Root Diameter
- 0.141** Nominal Ball Diameter
- 1.22** Screw Weight (lbs./ft.)

SBN Double Circuit Ball Nut		78 bearing balls per circuit - 156 total per nut
PRODUCT SPECIFICATIONS	RH	
Dynamic Load (lbs.)	2,723	
Static Load (lbs.)	17,425	
Torque to Raise 1 lb. (in.-lb.)	.088	
Nut Weight (lbs.)	.8	
Ball Nut Number	SBN7500	
Flange Part Number	FLG7555	
Wiper Kit Part Number	WKB7200	

SEL Adjustable Preload Ball Nut		78 bearing balls per circuit - 312 total per nut
PRODUCT SPECIFICATIONS	RH	
Dynamic Load (lbs.)	2,723	
Static Load (lbs.)	17,425	
Torque to Raise 1 lb. (in.-lb.)	.088	
Preload Range (lbs.)	272-817	
Nut Weight (lbs.)	.8	
Ball Nut Number	SEL10058	
Flange Part Number	FLG7555	
Wiper Kit Part Number	WKB7200	

Flange - FLG7555

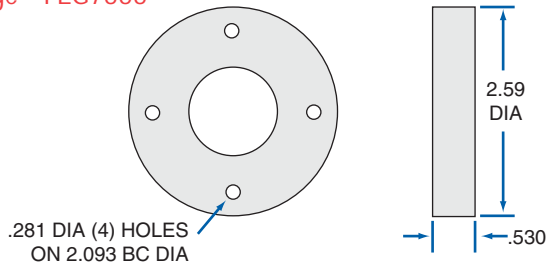

Brush Wiper Kit - WKB7200

2 wipers and
1 retainer

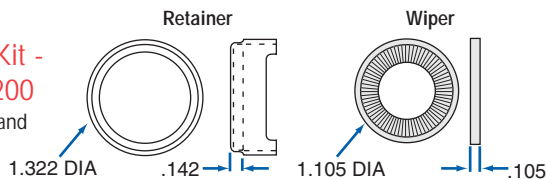

BALL SCREW ASSEMBLIES

These assemblies are shipped with screw, nut, flange, and bearing supports.

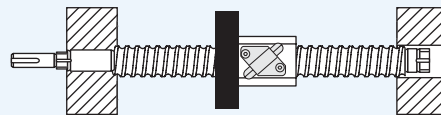

See page 145 for complete product details.

EZZE-MOUNT™ END BEARING SUPPORTS

A convenient solution for mounting ball screw assemblies.

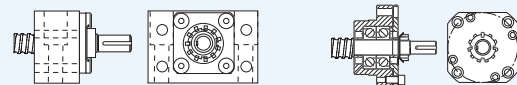

Single or Double Bearing
Universal Mount

Single or Double Bearing
Flange Mount

See page 214 for complete product details.

0875-0200 SRT

LEAD ACCURACY: ± 0.004 in./ft.

Single Start

0.875 Ball Circle Diameter

0.200 Lead

0.735 Root Diameter

0.125 Nominal Ball Diameter

1.78 Screw Weight (lbs./ft.)

Standard Screw Lengths	PART NUMBERS
	RH
4 FT.	SRT8541
8 FT.	SRT8553
12 FT.	SRT8859

Custom cut lengths available up to 24'. For longer lengths contact Customer Service.

INCH BALL SCREW AND NUT TECHNICAL DATA

SBN Double Circuit Ball Nut

91 bearing balls per circuit - 182 total per nut

PRODUCT SPECIFICATIONS	RH
Dynamic Load (lbs.)	1,942
Static Load (lbs.)	18,063
Torque to Raise 1 lb. (in.-lb.)	.035
Nut Weight (lbs.)	.7
Ball Nut Number	SBN8277
Flange Part Number	FLG8281
Wiper Kit Part Number	WKB2648

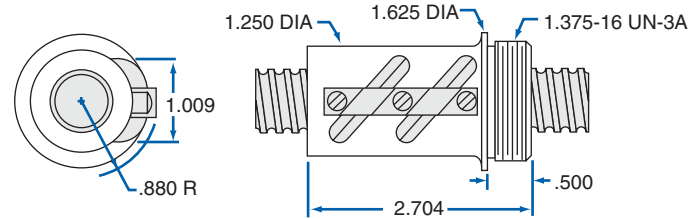

SAR Adjustable Preload Ball Nut with Wipers

91 bearing balls per circuit - 182 total per nut

PRODUCT SPECIFICATIONS	RH
Dynamic Load (lbs.)	971
Static Load (lbs.)	9,482
Torque to Raise 1 lb. (in.-lb.)	.035
Preload (lbs.)	97-291
Nut Weight (lbs.)	1.8
Ball Nut Number	SAR3040
Flange	INTEGRAL
Wiper Type	FELT

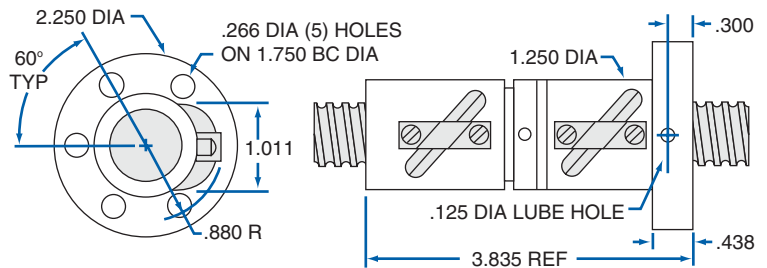

Flange - FLG8281

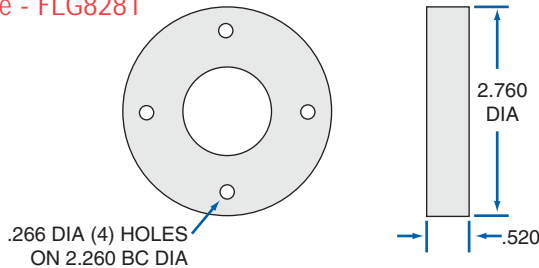

BALL SCREW ASSEMBLIES

These assemblies are shipped with screw, nut, flange, and bearing supports.

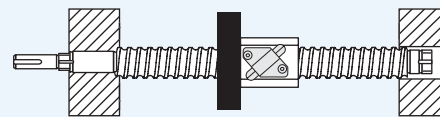

See page 145 for complete product details.

Brush Wiper Kit - WKB2648

2 wipers and
1 retainer

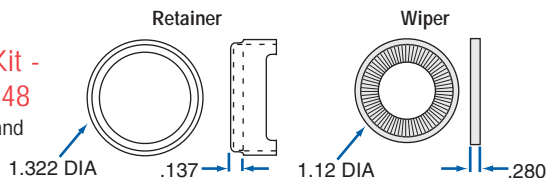

EZZE-MOUNT™ END BEARING SUPPORTS

A convenient solution for mounting ball screw assemblies.

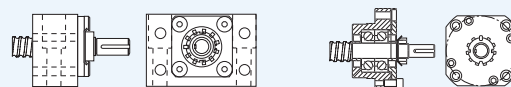

Single or Double Bearing
Universal Mount

Single or Double Bearing
Flange Mount

See page 214 for complete product details.

Standard Screw Lengths	PART NUMBERS	
	XPR RH	SGT RH
4 FT.	XPR8720R48	GT08720R48
8 FT.	XPR8720R96	—

XPR custom cut lengths available up to 12',
SGT custom cut lengths available up to 5', contact Customer Service.

0875-0200 XPR and SGT

LEAD ACCURACY: XPR ±0.001 in./ft. SGT ±0.0005 in./ft.

Single Start

- 0.875** Ball Circle Diameter
- 0.200** Lead
- 0.735** Root Diameter
- 0.125** Nominal Ball Diameter
- 1.8** Screw Weight (lbs./ft.)

PRN Preloaded Ball Nut with Wipers		93 bearing balls per circuit - 186 total per nut
PRODUCT SPECIFICATIONS	RH	
Dynamic Load (lbs.)	1,375	
Static Load (lbs.)	10,780	
Torque to Raise 1 lb. (in.-lb.)	.035	
Spring Rate x 10 ⁶ (lb./in.)	3.10	
Nut Weight (lbs.)	1.1	
Ball Nut Number	PRN10110	
Flange Part Number	FLG8281	
Wiper Type	ELASTOMER	

SSN Preloaded Flanged Ball Nut with Wipers		93 bearing balls per circuit - 186 total per nut
PRODUCT SPECIFICATIONS	RH	
Dynamic Load (lbs.)	1,375	
Static Load (lbs.)	10,780	
Torque to Raise 1 lb. (in.-lb.)	.035	
Spring Rate x 10 ⁶ (lb./in.)	3.10	
Nut Weight (lbs.)	1.4	
Ball Nut Number	SSN0388	
Flange	INTEGRAL	
Wiper Type	ELASTOMER	

SAG Adjustable Preload Flanged Ball Nut with Wipers		93 bearing balls per circuit - 186 total per nut
PRODUCT SPECIFICATIONS	RH	
Dynamic Load (lbs.)	1,375	
Static Load (lbs.)	10,780	
Torque to Raise 1 lb. (in.-lb.)	.035	
Preload (lbs.)	220	
Nut Weight (lbs.)	1.8	
Ball Nut Number	SAG0702	
Flange	INTEGRAL	
Wiper Type	FELT	

BALL SCREW ASSEMBLIES

These assemblies are shipped with screw, nut, flange, and bearing supports.

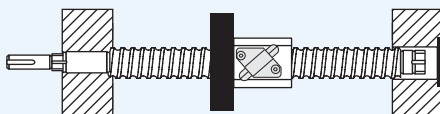

See page 145 for complete product details.

EZZE-MOUNT™ END BEARING SUPPORTS

A convenient solution for mounting ball screw assemblies.

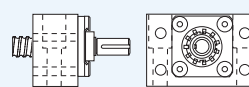

Single or Double Bearing
Universal Mount

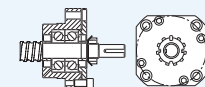

Single or Double Bearing
Flange Mount

See page 214 for complete product details.

INCH BALL SCREW AND NUT TECHNICAL DATA

1000-0200 SGT

LEAD ACCURACY: ± 0.0005 in./ft.

Single Start

- 1.000** Ball Circle Diameter
- 0.200** Lead
- 0.865** Root Diameter
- 0.125** Nominal Ball Diameter
- 2.2** Screw Weight (lbs./ft.)

Standard Screw Lengths	PART NUMBERS
6 FT.	GT10020R72
Custom cut lengths available up to 6', contact Customer Service.	

INCH BALL SCREW AND NUT TECHNICAL DATA

SSN Preloaded Flanged Ball Nut with Wipers

107 bearing balls per circuit - 214 total per nut

PRODUCT SPECIFICATIONS	RH
Dynamic Load (lbs.)	1,565
Static Load (lbs.)	13,073
Torque to Raise 1 lb. (in.-lb.)	.035
Spring Rate x 10 ⁶ (lb./in.)	3.50
Nut Weight (lbs.)	1.5
Ball Nut Number	SSN0391
Flange	INTEGRAL
Wiper Type	ELASTOMER

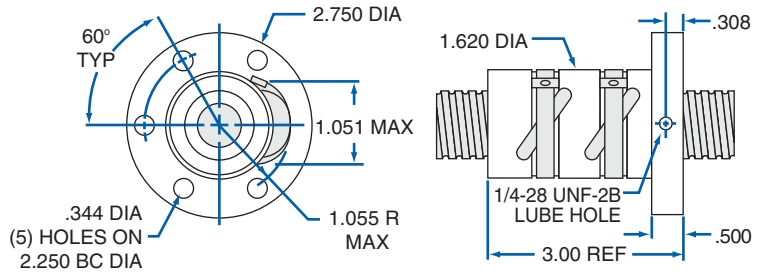

BALL SCREW ASSEMBLIES

These assemblies are shipped with screw, nut, flange, and bearing supports.

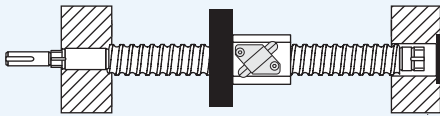

See page 145 for complete product details.

EZZE-MOUNT™ END BEARING SUPPORTS

A convenient solution for mounting ball screw assemblies.

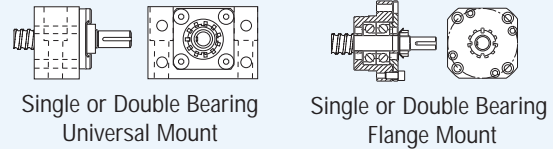

See page 214 for complete product details.

END MACHINING

Machining for Nook standard ends or custom requirement available.

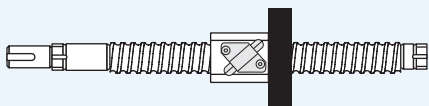

See page 212 for complete product details.

LUBRICANT

Prolong ball screw and nut performance with this special lubricant.



E-900 12oz. Spray or 32oz. Liquid
See page 95 for complete product details.



Standard Screw Lengths	PART NUMBERS		
	RH	LH	RHSS
4 FT.	SRT5005	SRT5499	SRT6668
8 FT.	SRT5013	SRT5507	SRT6676
12 FT.	SRT5021	SRT5515	SRT6684
16 FT.	SRT0426	SRT0428	—
Custom cut lengths available up to 24' for alloy, up to 12' for stainless. For longer lengths contact Customer Service.			

1000-0250 SRT

LEAD ACCURACY: ±0.004 in./ft.

Single Start

- 1.000** Ball Circle Diameter
- 0.250** Lead
- 0.820** Root Diameter
- 0.156** Nominal Ball Diameter
- 2.2** Screw Weight (lbs./ft.)

SBN Single Circuit Ball Nut				86 bearing balls total per nut
PRODUCT SPECIFICATIONS	RH	LH	RHSS	
Dynamic Load (lbs.)	1,612	1,612	290	
Static Load (lbs.)	13,913	13,913	2,504	
Torque to Raise 1 lb. (in.-lb.)	.044	.044	.044	
Nut Weight (lbs.)	.8	.8	.8	
Ball Nut Number	SBN10466	SBN10468	SBN10470	
Flange Part Number	FLG7571	FLG7571	—	
Wiper Kit Part Number	WKB1050	WKB1050	WKB1050	

SBN Double Circuit Ball Nut				86 bearing balls per circuit - 172 total per nut
PRODUCT SPECIFICATIONS	RH	LH	RHSS	
Dynamic Load (lbs.)	3,224	—	—	
Static Load (lbs.)	27,826	—	—	
Torque to Raise 1 lb. (in.-lb.)	.044	—	—	
Nut Weight (lbs.)	1.2	—	—	
Ball Nut Number	SBN10472	—	—	
Flange Part Number	FLG7571	—	—	
Wiper Kit Part Number	WKB1050	—	—	

SBN Double Circuit Flanged Ball Nut				86 bearing balls per circuit - 172 total per nut
PRODUCT SPECIFICATIONS	RH	LH	RHSS	
Dynamic Load (lbs.)	3,224	3,224	—	
Static Load (lbs.)	27,826	27,826	—	
Torque to Raise 1 lb. (in.-lb.)	.044	.044	—	
Nut Weight (lbs.)	1.5	1.5	—	
Ball Nut Number	SBN8278	SBN8284	—	
Flange	INTEGRAL	INTEGRAL	—	
Wiper Kit Part Number	WKB2651	WKB2651	—	

Flange - FLG7571

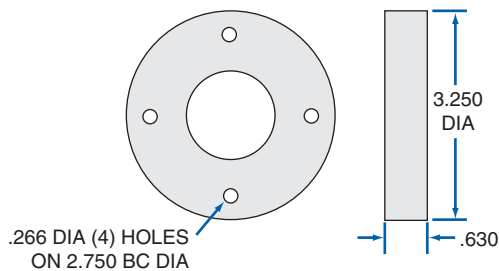

Brush Wiper Kit - WKB1050

2 wipers and 1 retainer

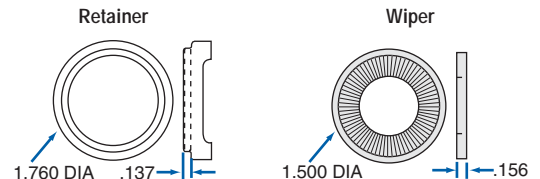

Brush Wiper Kit - WKB2651

2 wipers and 1 retainer

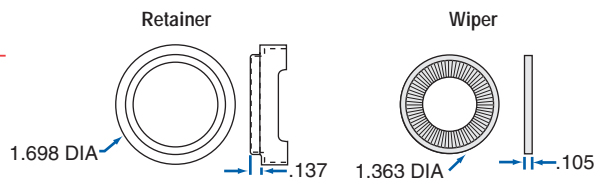

1000-0250 SRT continued

LEAD ACCURACY: ±0.004 in./ft.

Single Start

- 1.000** Ball Circle Diameter
- 0.250** Lead
- 0.820** Root Diameter
- 0.156** Nominal Ball Diameter
- 2.2** Screw Weight (lbs./ft.)

Standard Screw Lengths	PART NUMBERS		
	RH	LH	RHSS
4 FT.	SRT5005	SRT5499	SRT6668
8 FT.	SRT5013	SRT5507	SRT6676
12 FT.	SRT5021	SRT5515	SRT6684
16 FT.	SRT0426	SRT0428	—

Custom cut lengths available up to 24' for alloy, up to 12' for stainless.
For longer lengths contact Customer Service.

SEL Preload Ball Nut

86 bearing balls per circuit - 172 total per nut

PRODUCT SPECIFICATIONS	RH	LH	RHSS
Dynamic Load (lbs.)	1,612	1,612	—
Static Load (lbs.)	13,913	13,913	—
Torque to Raise 1 lb. (in.-lb.)	.044	.044	—
Preload (lbs.)	330	330	—
Nut Weight (lbs.)	1.9	1.9	—
Ball Nut Number	SEL10474	SEL10477	—
Flange Part Number	FLG7571	FLG7571	—
Wiper Kit Part Number	WKB1050	WKB1050	—

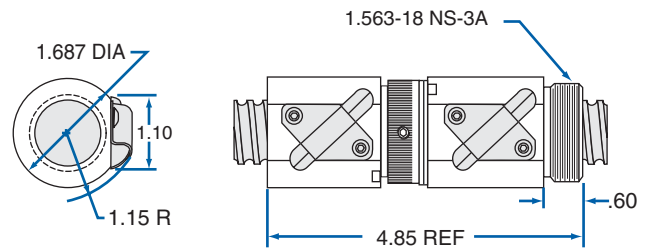

SAR Adjustable Preload Flanged Ball Nut

86 bearing balls per circuit - 172 total per nut

PRODUCT SPECIFICATIONS	RH	LH	RHSS
Dynamic Load (lbs.)	1,612	—	—
Static Load (lbs.)	13,913	—	—
Torque to Raise 1 lb. (in.-lb.)	.044	—	—
Preload Range (lbs.)	330	—	—
Nut Weight (lbs.)	2.0	—	—
Ball Nut Number	SAR3041	—	—
Flange	INTEGRAL	—	—
Wiper Type	—	—	—

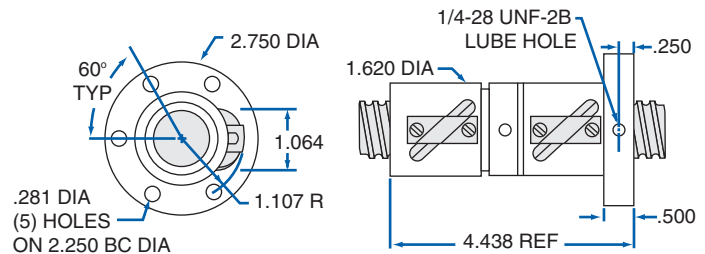

INCH BALL SCREW AND NUT TECHNICAL DATA

BALL SCREW ASSEMBLIES

These assemblies are shipped with screw, nut, flange, and bearing supports.

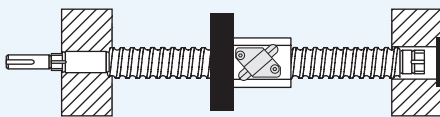

See page 145 for complete product details.

EZZE-MOUNT™

END BEARING SUPPORTS

A convenient solution for mounting ball screw assemblies.

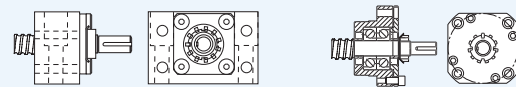

Single or Double Bearing
Universal Mount

Single or Double Bearing
Flange Mount

See page 214 for complete product details.

TWIN-LEAD SCREW

Single piece twin-lead screws offer opposing motion through a single drive system.

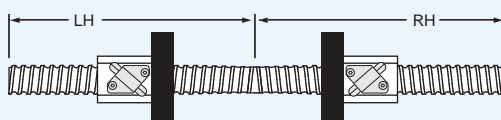

See page 148 for complete product details.

LUBRICANT

Prolong ball screw and nut performance with this special lubricant.



E-900 12oz. Spray or 32oz. Liquid
See page 95 for complete product details.

Standard Screw Lengths	PART NUMBERS	
	XPR RH	SGT RH
6 FT.	XPR10025R72	GT10025R72
12 FT.	XPR10025R144	—

XPR custom cut lengths available up to 12',
SGT custom cut lengths available up to 6', contact Customer Service.

1000-0250 XPR and SGT

LEAD ACCURACY: XPR ±0.001 in./ft. SGT ±0.0005 in./ft.

Single Start

- 1.000** Ball Circle Diameter
- 0.250** Lead
- 0.820** Root Diameter
- 0.156** Nominal Ball Diameter
- 2.2** Screw Weight (lbs./ft.)

PRN Preloaded Ball Nut with Wipers		86 bearing balls per circuit - 172 total per nut
PRODUCT SPECIFICATIONS	RH	
Dynamic Load (lbs.)	2,285	
Static Load (lbs.)	15,815	
Torque to Raise 1 lb. (in.-lb.)	.044	
Spring Rate x 10 ⁶ (lb./in.)	1.7	
Nut Weight (lbs.)	3.50	
Ball Nut Number	PRN10111	
Flange Part Number	FLG7576*	
Wiper Type	ELASTOMER	
* See page 116 for Flange dimensions.		

SGN Ball Nut or PRN Preloaded Ball Nut			86 bearing balls per circuit - 172 total per nut
PRODUCT SPECIFICATIONS	SGN-RH	PRN-RH	
Dynamic Load (lbs.)	4,570	2,285	
Static Load (lbs.)	31,630	15,815	
Torque to Raise 1 lb. (in.-lb.)	.044	.044	
Spring Rate x 10 ⁶ (lb./in.)	No Preload	2.50	
Nut Weight (lbs.)	1.5	1.5	
Ball Nut Number	SGN10117	PRN10115	
Flange Part Number	FLG7571	FLG7571	
Wiper Kit Part Number	—	—	

SSN Preloaded Flanged Ball Nut with Wipers		86 bearing balls per circuit - 172 total per nut
PRODUCT SPECIFICATIONS	RH	
Dynamic Load (lbs.)	2,285	
Static Load (lbs.)	15,815	
Torque to Raise 1 lb. (in.-lb.)	.044	
Spring Rate x 10 ⁶ (lb./in.)	3.50	
Nut Weight (lbs.)	2.0	
Ball Nut Number	SSN0404	
Flange	INTEGRAL	
Wiper Type	ELASTOMER	

SAG Adjustable Preload Flanged Ball Nut with Wipers		86 bearing balls per circuit - 172 total per nut
PRODUCT SPECIFICATIONS	RH	
Dynamic Load (lbs.)	2,285	
Static Load (lbs.)	15,815	
Torque to Raise 1 lb. (in.-lb.)	.044	
Preload (lbs.)	330	
Nut Weight (lbs.)	2.0	
Ball Nut Number	SAG0703	
Flange	INTEGRAL	
Wiper Type	BRUSH	

INCH BALL SCREW AND NUT TECHNICAL DATA

1000-0500 SRT

LEAD ACCURACY: ±0.004 in./ft.

Double Start

- 1.000** Ball Circle Diameter
- 0.500** Lead
- 0.820** Root Diameter
- 0.156** Nominal Ball Diameter
- 2.2** Screw Weight (lbs./ft.)

Standard Screw Lengths	PART NUMBERS
	RH
4 FT.	SRT9990
8 FT.	SRT9991
12 FT.	SRT9992
16 FT.	SRT9993

Custom cut lengths available up to 24'. For longer lengths contact Customer Service.

INCH BALL SCREW AND NUT TECHNICAL DATA

SBN Double Circuit Ball Nut

91 bearing balls per circuit - 182 total per nut

PRODUCT SPECIFICATIONS	RH
Dynamic Load (lbs.)	3,440
Static Load (lbs.)	25,250
Torque to Raise 1 lb. (in.-lb.)	.088
Nut Weight (lbs.)	1.2
Ball Nut Number	SBN1050
Flange Part Number	FLG7571
Wiper Kit Part Number	WKB1050

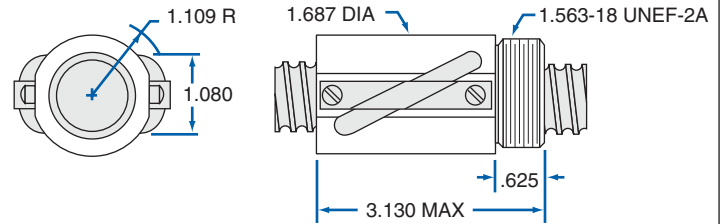

SEL Adjustable Preload Integral Wipers Ball Nut

91 bearing balls per circuit - 364 total per nut

PRODUCT SPECIFICATIONS	RH
Dynamic Load (lbs.)	3,440
Static Load (lbs.)	25,250
Torque to Raise 1 lb. (in.-lb.)	.088
Preload Range (lbs.)	272-817
Nut Weight (lbs.)	2.6
Ball Nut Number	SEL10066
Flange Part Number	FLG7571
Wiper Kit Part Number	WKB1050

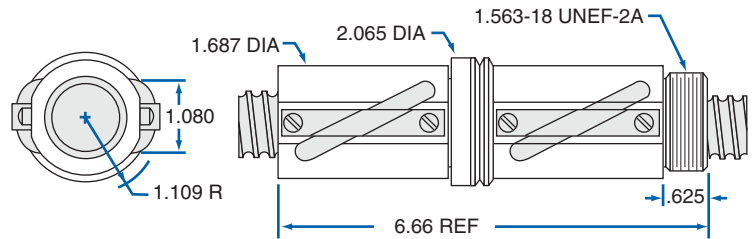

Flange - FLG7571

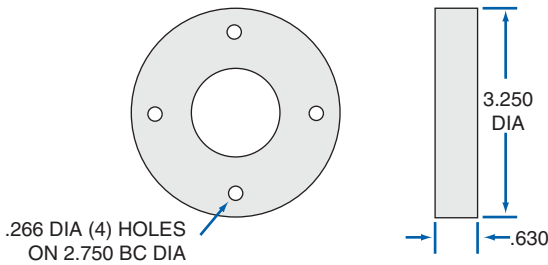

BALL SCREW ASSEMBLIES

These assemblies are shipped with screw, nut, flange, and bearing supports.

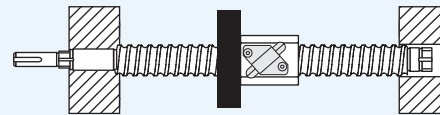

See page 145 for complete product details.

Brush Wiper Kit - WKB1050

2 wipers and 1 retainer

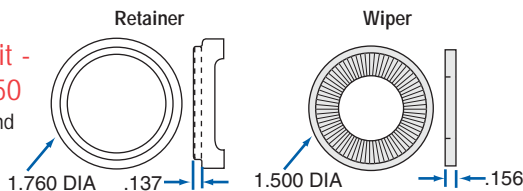

EZZE-MOUNT™ END BEARING SUPPORTS

A convenient solution for mounting ball screw assemblies.

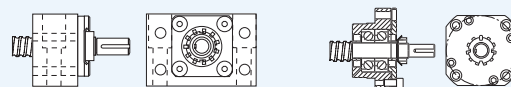

Single or Double Bearing
Universal Mount

Single or Double Bearing
Flange Mount

See page 214 for complete product details.

Standard Screw Lengths	PART NUMBERS	
	RH	
4 FT.	SRT6814	
8 FT.	SRT6822	
12 FT.	SRT6830	
16 FT.	SRT0429	

Custom cut lengths available up to 24'. For longer lengths contact Customer Service.

1000-1000 SRT

LEAD ACCURACY: ±0.004 in./ft.

Four Start

- 1.000** Ball Circle Diameter
- 1.000** Lead
- 0.820** Root Diameter
- 0.156** Nominal Ball Diameter
- 2.2** Screw Weight (lbs./ft.)

SBN Double Circuit Ball Nut		50 bearing balls per circuit - 100 total per nut
PRODUCT SPECIFICATIONS	RH	
Dynamic Load (lbs.)	2,142	
Static Load (lbs.)	11,925	
Torque to Raise 1 lb. (in.-lb.)	.177	
Nut Weight (lbs.)	1.11	
Ball Nut Number	SBN10461	
Flange Part Number	FLG7571	
Wiper Kit Part Number	WKB1050	

SEL Adjustable Preload Ball Nut		50 bearing balls per circuit - 200 total per nut
PRODUCT SPECIFICATIONS	RH	
Dynamic Load (lbs.)	2,142	
Static Load (lbs.)	11,925	
Torque to Raise 1 lb. (in.-lb.)	.177	
Preload (lbs.)	300	
Nut Weight (lbs.)	2.5	
Ball Nut Number	SEL10462	
Flange Part Number	FLG7571	
Wiper Kit Part Number	WKB1050	

Flange - FLG7571

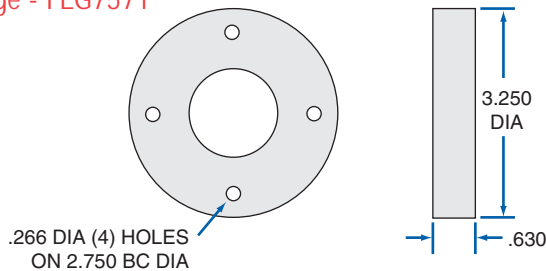

Brush Wiper Kit - WKB1050

2 wipers and
1 retainer

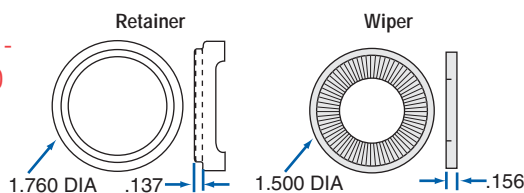

BALL SCREW ASSEMBLIES

These assemblies are shipped with screw, nut, flange, and bearing supports.

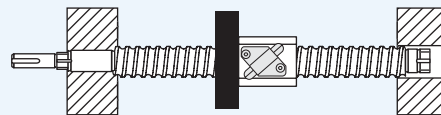

See page 145 for complete product details.

EZZE-MOUNT™ END BEARING SUPPORTS

A convenient solution for mounting ball screw assemblies.

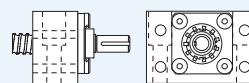

Single or Double Bearing
Universal Mount

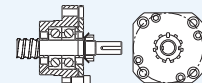

Single or Double Bearing
Flange Mount

See page 214 for complete product details.

1150-0200 SRT

LEAD ACCURACY: ± 0.004 in./ft.

Single Start

- 1.150** Ball Circle Diameter
- 0.200** Lead
- 1.015** Root Diameter
- 0.125** Nominal Ball Diameter
- 3.18** Screw Weight (lbs./ft.)

Standard Screw Lengths	PART NUMBERS	
	RH	LH
4 FT.	SRT8738	SRT0285
8 FT.	SRT8746	SRT0286
12 FT.	SRT8753	SRT0287
16 FT.	SRT0430	SRT0431

Custom cut lengths available up to 24'. For longer lengths contact Customer Service.

INCH BALL SCREW AND NUT TECHNICAL DATA

SBN Double Circuit Ball Nut

121 bearing balls per circuit - 242 total per nut

PRODUCT SPECIFICATIONS	RH	LH
Dynamic Load (lbs.)	2,370	2,370
Static Load (lbs.)	26,180	26,180
Torque to Raise 1 lb. (in.-lb.)	.035	.035
Nut Weight (lbs.)	.9	.9
Ball Nut Number	SBN1566	SBN0207
Flange Part Number	FLG8283	FLG8283
Wiper Kit Part Number	WKB2652	WKB2652

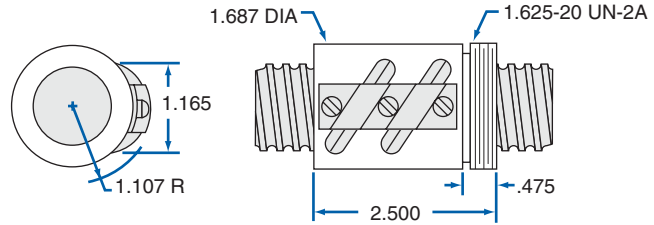

SEL Adjustable Preload Ball Nut

121 bearing balls per circuit - 242 total per nut

PRODUCT SPECIFICATIONS	RH	LH
Dynamic Load (lbs.)	1,185	1,185
Static Load (lbs.)	13,090	13,090
Torque to Raise 1 lb. (in.-lb.)	.035	.035
Preload (lbs.)	240	240
Nut Weight (lbs.)	1.34	1.34
Ball Nut Number	SEL4270	SEL0206
Flange Part Number	FLG8283	FLG8283
Wiper Kit Part Number	WKB2652	WKB2652

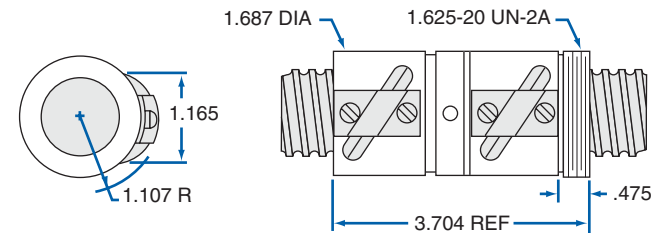

SAR Adjustable Preload Flanged Ball Nut

121 bearing balls per circuit - 242 total per nut

PRODUCT SPECIFICATIONS	RH	LH
Dynamic Load (lbs.)	1,185	—
Static Load (lbs.)	13,090	—
Torque to Raise 1 lb. (in.-lb.)	.035	—
Preload (lbs.)	240	—
Nut Weight (lbs.)	1.8	—
Ball Nut Number	SAR3042	—
Flange	INTEGRAL	—
Wiper Type	BRUSH	—

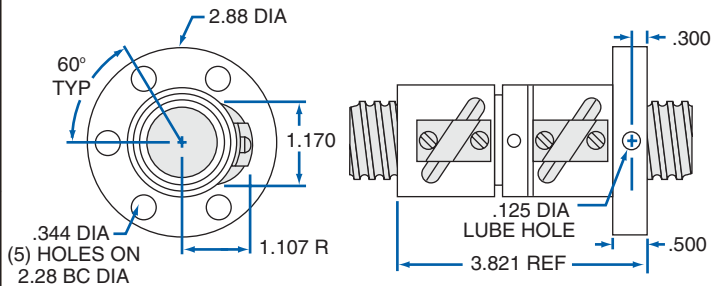

Flange - FLG8283

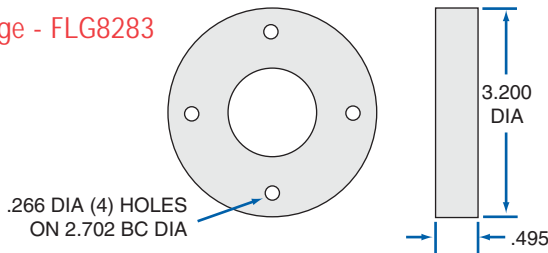

Brush
Wiper Kit -
WKB2652

2 wipers and
1 retainer

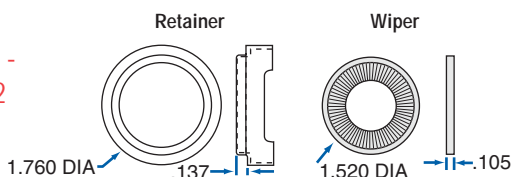

TWIN-LEAD SCREW

Single piece twin-lead screws offer opposing motion through a single drive system.

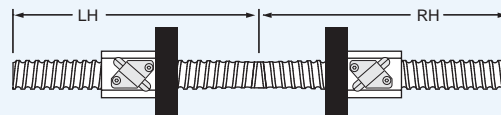

See page 148 for complete product details.

LUBRICANT

Prolong ball screw and nut performance with this special lubricant.
See page 95 for complete product details.

Standard Screw Lengths	PART NUMBERS	
	XPR RH	SGT RH
6 FT.	XPR11520R72	GT11520R72
12 FT.	XPR11520R144	—

XPR custom cut lengths available up to 12',
SGT custom cut lengths available up to 6', contact Customer Service.

1150-0200 XPR and SGT

LEAD ACCURACY: XPR ±0.001 in./ft. SGT ±0.0005 in./ft.

Single Start

- 1.150** Ball Circle Diameter
- 0.200** Lead
- 1.015** Root Diameter
- 0.125** Nominal Ball Diameter
- 3.18** Screw Weight (lbs./ft.)

PRN Preloaded Ball Nut with Wipers

121 bearing balls per circuit - 242 total per nut

PRODUCT SPECIFICATIONS	RH
Dynamic Load (lbs.)	1,680
Static Load (lbs.)	14,886
Torque to Raise 1 lb. (in.-lb.)	.035
Spring Rate x 10 ⁶ (lb./in.)	4.25
Nut Weight (lbs.)	1.45
Ball Nut Number	PRN10112
Flange Part Number	FLG7576*
Wiper Type	ELASTOMER

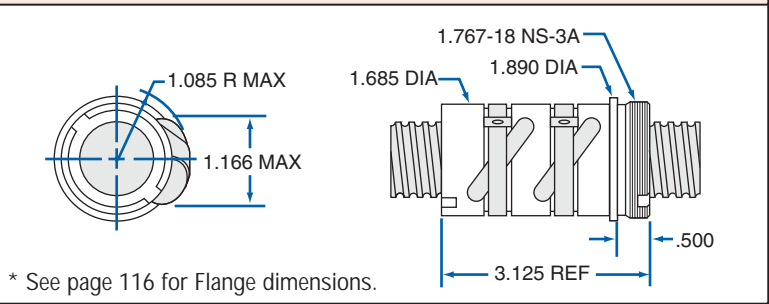

SSN Preloaded Flanged Ball Nut with Wipers

121 bearing balls per circuit - 242 total per nut

PRODUCT SPECIFICATIONS	RH
Dynamic Load (lbs.)	1,680
Static Load (lbs.)	14,886
Torque to Raise 1 lb. (in.-lb.)	.035
Spring Rate x 10 ⁶ (lb./in.)	4.25
Nut Weight (lbs.)	2.0
Ball Nut Number	SSN0392
Flange	INTEGRAL
Wiper Type	ELASTOMER

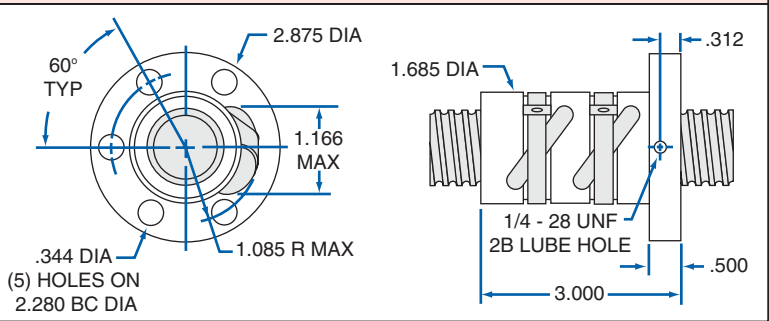

SAG Adjustable Preload Flanged Ball Nut

121 bearing balls per circuit - 242 total per nut

PRODUCT SPECIFICATIONS	RH
Dynamic Load (lbs.)	1,680
Static Load (lbs.)	14,886
Torque to Raise 1 lb. (in.-lb.)	.035
Preload (lbs.)	240
Nut Weight (lbs.)	1.8
Ball Nut Number	SAG0704
Flange	INTEGRAL
Wiper Type	BRUSH

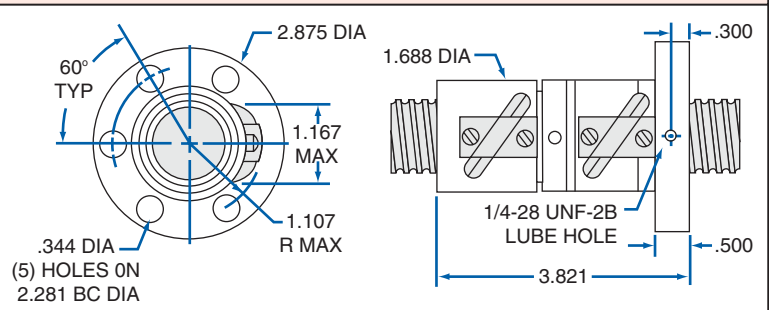

BALL SCREW ASSEMBLIES

These assemblies are shipped with screw, nut, flange, and bearing supports.

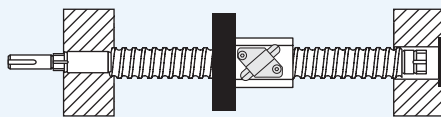

See page 145 for complete product details.

EZZE-MOUNT™ END BEARING SUPPORTS

A convenient solution for mounting ball screw assemblies.

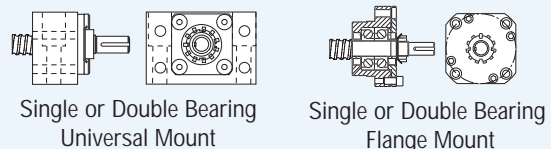

See page 214 for complete product details.

INCH BALL SCREW AND NUT TECHNICAL DATA



1171-0413 SRT

LEAD ACCURACY: ±0.004 in./ft.

Single Start

- 1.171** Ball Circle Diameter
- 0.413** Lead
- 0.870** Root Diameter
- 0.281** Nominal Ball Diameter
- 2.77** Screw Weight (lbs./ft.)

Standard Screw Lengths	PART NUMBERS
	RH
4 FT.	SRT9569
8 FT.	SRT5035
12 FT.	SRT5043
16 FT.	SRT0432

Custom cut lengths available up to 24'. For longer lengths contact Customer Service.

INCH BALL SCREW AND NUT TECHNICAL DATA

SBN Double Circuit Ball Nut

28 bearing balls per circuit - 56 total per nut

PRODUCT SPECIFICATIONS	RH
Dynamic Load (lbs.)	3,894
Static Load (lbs.)	22,917
Torque to Raise 1 lb. (in.-lb.)	.073
Nut Weight (lbs.)	1.9
Ball Nut Number	SBN7511
Flange Part Number	FLG7572
Wiper Kit Part Number	WKB2653

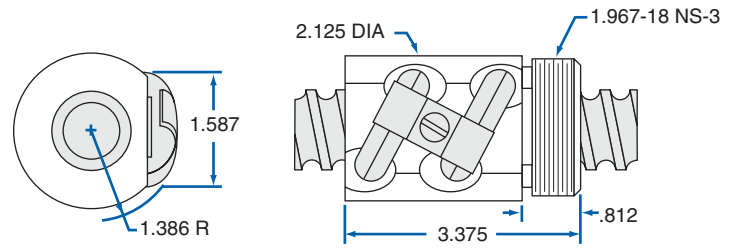

Flange - FLG7572

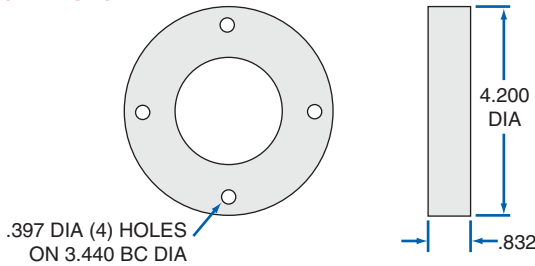

BALL SCREW ASSEMBLIES

These assemblies are shipped with screw, nut, flange, and bearing supports.

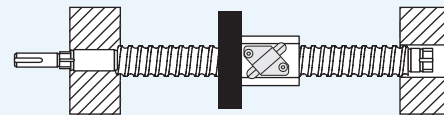

See page 145 for complete product details.

Brush Wiper Kit - WKB2653

2 wipers and 1 retainer

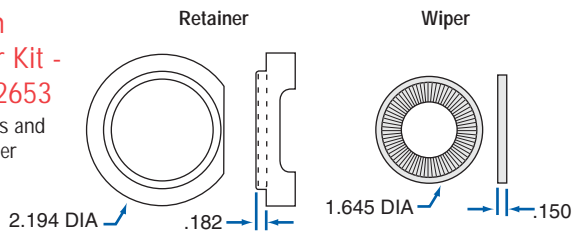

EZZE-MOUNT™ END BEARING SUPPORTS

A convenient solution for mounting ball screw assemblies.

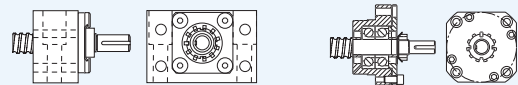

Single or Double Bearing Universal Mount

Single or Double Bearing Flange Mount

See page 214 for complete product details.

LUBRICANT

Prolong ball screw and nut performance with this special lubricant.



E-900 12oz. Spray or 32oz. Liquid
See page 95 for complete product details.

END MACHINING

Machining for Nook standard ends or custom requirement available.

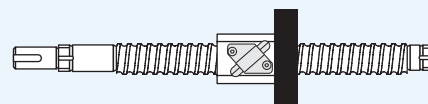

See page 212 for complete product details.

Standard Screw Lengths	PART NUMBERS	
	RH	LH
4 FT.	SRT1224	SRT1223
8 FT.	SRT1228	SRT1227
12 FT.	SRT1222	SRT1221
16 FT.	SRT1226	SRT1225

Custom cut lengths available up to 24'. For longer lengths contact Customer Service.

1250-0200 SRT

LEAD ACCURACY: ±0.004 in./ft.

Single Start

- 1.250** Ball Circle Diameter
- 0.200** Lead
- 1.115** Root Diameter
- 0.125** Nominal Ball Diameter
- 3.7** Screw Weight (lbs./ft.)

SBN Double Circuit Ball Nut			130 bearing balls per circuit - 260 total per nut
PRODUCT SPECIFICATIONS	RH	LH	
Dynamic Load (lbs.)	3,336	3,336	
Static Load (lbs.)	34,688	34,688	
Torque to Raise 1 lb. (in.-lb.)	.035	.035	
Nut Weight (lbs.)	1.8	1.8	
Ball Nut Number	SBN10187	SBN10189	
Flange Part Number	FLG8283	FLG8283	
Wiper Type	ELASTOMER	ELASTOMER	

Flange - FLG8283

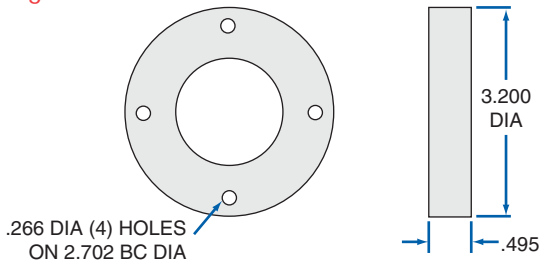

BALL SCREW ASSEMBLIES

These assemblies are shipped with screw, nut, flange, and bearing supports.

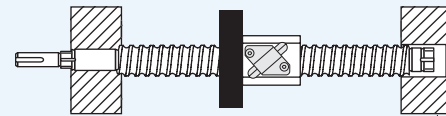

See page 145 for complete product details.

END MACHINING

Machining for Nook standard ends or custom requirement available.

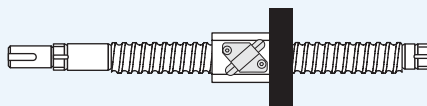

See page 212 for complete product details.

EZZE-MOUNT™ END BEARING SUPPORTS

A convenient solution for mounting ball screw assemblies.

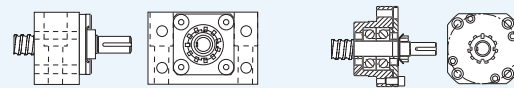

Single or Double Bearing
Universal Mount

Single or Double Bearing
Flange Mount

See page 214 for complete product details.

LUBRICANT

Prolong ball screw and nut performance with this special lubricant.



E-900 12oz. Spray or 32oz. Liquid
See page 95 for complete product details.

TWIN-LEAD SCREW

Single piece twin-lead screws offer opposing motion through a single drive system.

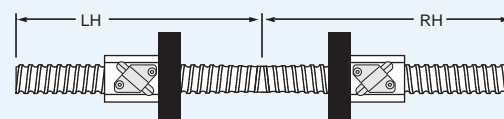

See page 148 for complete product details.

1250-0200 XPR and SGT

LEAD ACCURACY: XPR ± 0.001 in./ft. SGT ± 0.0005 in./ft.

Single Start

- 1.250** Ball Circle Diameter
- 0.200** Lead
- 1.115** Root Diameter
- 0.125** Nominal Ball Diameter
- 3.7** Screw Weight (lbs./ft.)

Standard Screw Lengths	PART NUMBERS		
	XPR-RH	SGT-RH	SGT-LH
6 FT.	XPR12520R72	GT12520R72	GT12520L72
12 FT.	XPR12520R144	—	—

XPR custom cut lengths available up to 12',
SGT custom cut lengths available up to 6', contact Customer Service.

INCH BALL SCREW AND NUT TECHNICAL DATA

PRN Preloaded Ball Nut with Wipers			130 bearing balls per circuit - 260 total per nut
PRODUCT SPECIFICATIONS	RH	LH	
Dynamic Load (lbs.)	1,668	1,668	
Static Load (lbs.)	17,344	17,344	
Torque to Raise 1 lb. (in.-lb.)	.035	.035	
Spring Rate x 10 ⁶ (lb./in.)	4.25	4.25	
Nut Weight (lbs.)	1.8	1.8	
Ball Nut Number	PRN10191	PRN10193	
Flange Part Number	—	—	
Wiper Type	ELASTOMER	ELASTOMER	

SSN Preloaded Flanged Ball Nut with Wipers			130 bearing balls per circuit - 260 total per nut
PRODUCT SPECIFICATIONS	RH	LH	
Dynamic Load (lbs.)	1,668	1,668	
Static Load (lbs.)	17,344	17,344	
Torque to Raise 1 lb. (in.-lb.)	.035	.035	
Spring Rate x 10 ⁶ (lb./in.)	4.25	4.25	
Nut Weight (lbs.)	1.8	1.8	
Ball Nut Number	SSN0393	SSN0398	
Flange	INTEGRAL	INTEGRAL	
Wiper Type	ELASTOMER	ELASTOMER	

BALL SCREW ASSEMBLIES

These assemblies are shipped with screw, nut, flange, and bearing supports.

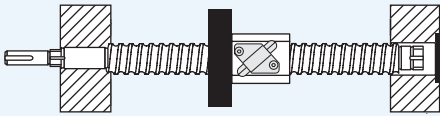

See page 145 for complete product details.

EZZE-MOUNT™ END BEARING SUPPORTS

A convenient solution for mounting ball screw assemblies.

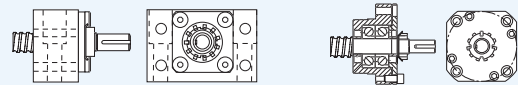

Single or Double Bearing
Universal Mount

Single or Double Bearing
Flange Mount

See page 214 for complete product details.

TWIN-LEAD SCREW

Single piece twin-lead screws offer opposing motion through a single drive system.

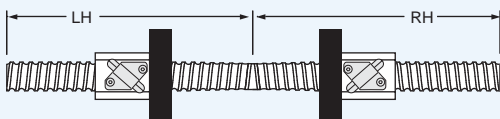

See page 148 for complete product details.

LUBRICANT

Prolong ball screw and nut performance with this special lubricant.



E-900 12oz. Spray or 32oz. Liquid
See page 95 for complete product details.

Standard Screw Lengths	PART NUMBERS	
	RH	
4 FT.	SRT1254	
8 FT.	SRT1258	
12 FT.	SRT1252	
16 FT.	SRT1256	

Custom cut lengths available up to 24'. For longer lengths contact Customer Service.

1250-0500 SRT

LEAD ACCURACY: ±0.004 in./ft.

Single Start

- 1.250** Ball Circle Diameter
- 0.500** Lead
- 1.050** Root Diameter
- 0.188** Nominal Ball Diameter
- 3.7** Screw Weight (lbs./ft.)

SBN Double Circuit Ball Nut		46 bearing balls per circuit - 92 total per nut
PRODUCT SPECIFICATIONS	RH	
Dynamic Load (lbs.)	2,745	
Static Load (lbs.)	17,235	
Torque to Raise 1 lb. (in.-lb.)	.088	
Nut Weight (lbs.)	1.8	
Ball Nut Number	SBN10104	
Flange Part Number	FLG7572	
Wiper Type	ELASTOMER	

Flange - FLG7572

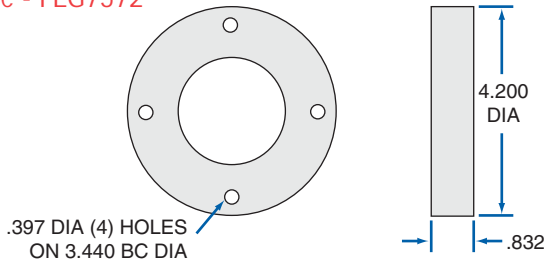

BALL SCREW ASSEMBLIES

These assemblies are shipped with screw, nut, flange, and bearing supports.

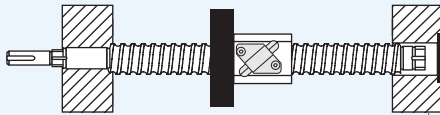

See page 145 for complete product details.

EZZE-MOUNT™ END BEARING SUPPORTS

A convenient solution for mounting ball screw assemblies.

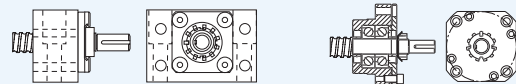

Single or Double Bearing
Universal Mount

Single or Double Bearing
Flange Mount

See page 214 for complete product details.

END MACHINING

Machining for Nook standard ends or custom requirement available.

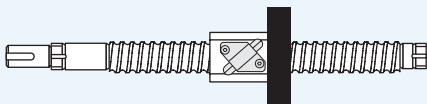

See page 212 for complete product details.

LUBRICANT

Prolong ball screw and nut performance with this special lubricant.

E-900 12oz. Spray or 32oz. Liquid
See page 95 for complete product details.



1250-0500 XPR and SGT

LEAD ACCURACY: XPR ± 0.001 in./ft. SGT ± 0.0005 in./ft.

Single Start

- 1.250** Ball Circle Diameter
- 0.500** Lead
- 1.050** Root Diameter
- 0.188** Nominal Ball Diameter
- 3.7** Screw Weight (lbs./ft.)

Standard Screw Lengths	PART NUMBERS	
	XPR RH	SGT RH
6 FT.	XPR12550R72	GT12550R72
12 FT.	XPR12550R144	—

XPR custom cut lengths available up to 12',
SGT custom cut lengths available up to 6', contact Customer Service.

INCH BALL SCREW AND NUT TECHNICAL DATA

PRN Preloaded Ball Nut with Wipers

46 bearing balls per circuit - 92 total per nut

PRODUCT SPECIFICATIONS	RH
Dynamic Load (lbs.)	1,765
Static Load (lbs.)	11,080
Torque to Raise 1 lb. (in.-lb.)	.088
Spring Rate x 10 ⁶ (lb./in.)	4.25
Nut Weight (lbs.)	2.75
Ball Nut Number	PRN10087
Flange Part Number	FLG7572
Wiper Type	ELASTOMER

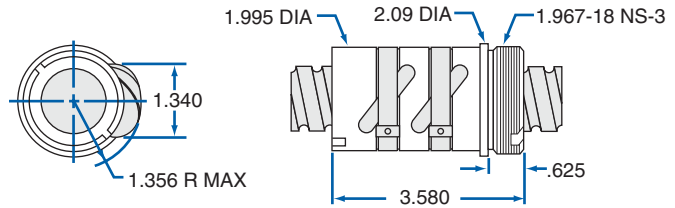

SSN Preloaded Flanged Ball Nut with Wipers

46 bearing balls per circuit - 92 total per nut

PRODUCT SPECIFICATIONS	RH
Dynamic Load (lbs.)	1,765
Static Load (lbs.)	11,080
Torque to Raise 1 lb. (in.-lb.)	.088
Spring Rate x 10 ⁶ (lb./in.)	4.25
Nut Weight (lbs.)	3.2
Ball Nut Number	SSN0399
Flange	INTEGRAL
Wiper Type	ELASTOMER

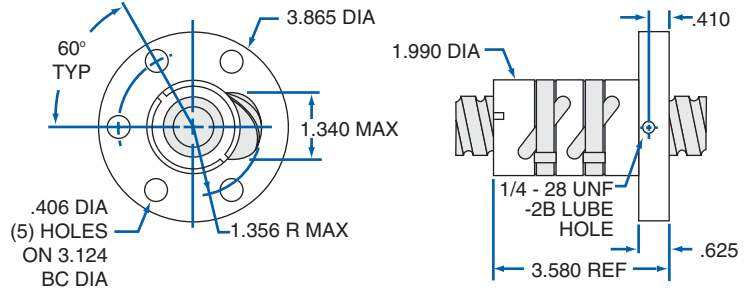

BALL SCREW ASSEMBLIES

These assemblies are shipped with screw, nut, flange, and bearing supports.

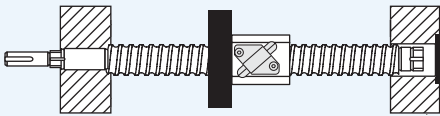

See page 145 for complete product details.

EZZE-MOUNT™

END BEARING SUPPORTS

A convenient solution for mounting ball screw assemblies.

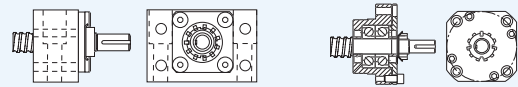

Single or Double Bearing
Universal Mount

Single or Double Bearing
Flange Mount

See page 214 for complete product details.

END MACHINING

Machining for Nook standard ends or custom requirement available.

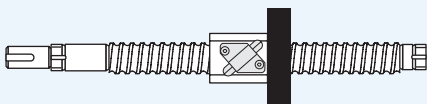

See page 212 for complete product details.

LUBRICANT

Prolong ball screw and nut performance with this special lubricant.

E-900 12oz. Spray or 32oz. Liquid
See page 95 for complete product details.



Standard Screw Lengths	PART NUMBERS
	SGT RH
6 FT.	GT15020R72
10 FT.	GT15020R120
Custom cut lengths available up to 10', contact Customer Service.	

1500-0200 SGT

LEAD ACCURACY: ±0.0005 in./ft.

Single Start

- 1.500** Ball Circle Diameter
- 0.200** Lead
- 1.349** Root Diameter
- 0.141** Nominal Ball Diameter
- 5.65** Screw Weight (lbs./ft.)

SSN Preloaded Flanged Ball Nut with Wipers		137 bearing balls per circuit - 548 total per nut
PRODUCT SPECIFICATIONS	RH	
Dynamic Load (lbs.)	4,745	
Static Load (lbs.)	45,073	
Torque to Raise 1 lb. (in.-lb.)	.035	
Spring Rate x 10 ⁶ (lb./in.)	5.00	
Nut Weight (lbs.)	3.8	
Ball Nut Number	SSN0394	
Flange	INTEGRAL	
Wiper Type	ELASTOMER	

INCH BALL SCREW AND NUT TECHNICAL DATA

BALL SCREW ASSEMBLIES

These assemblies are shipped with screw, nut, flange, and bearing supports.

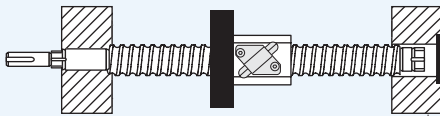

See page 145 for complete product details.

EZZE-MOUNT™ END BEARING SUPPORTS

A convenient solution for mounting ball screw assemblies.

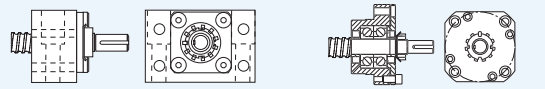

Single or Double Bearing
Universal Mount

Single or Double Bearing
Flange Mount

See page 214 for complete product details.

END MACHINING

Machining for Nook standard ends or custom requirement available.

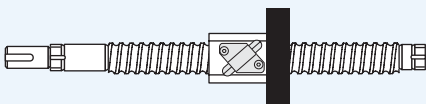

See page 212 for complete product details.

LUBRICANT

Prolong ball screw and nut performance with this special lubricant.



E-900 12oz. Spray or 32oz. Liquid
See page 95 for complete product details.

1500-0250 SRT

LEAD ACCURACY: ± 0.004 in./ft.

Single Start

- 1.500** Ball Circle Diameter
- 0.250** Lead
- 1.320** Root Diameter
- 0.156** Nominal Ball Diameter
- 5.16** Screw Weight (lbs./ft.)

Standard Screw Lengths	PART NUMBERS	
	RH	LH
4 FT.	SRT7012	SRT3252
8 FT.	SRT7020	SRT3253
12 FT.	SRT7028	SRT3254
16 FT.	SRT0433	SRT0434
20 FT.	SRT0595	SRT0596

Custom cut lengths available up to 24'. For longer lengths contact customer service.

INCH BALL SCREW AND NUT TECHNICAL DATA

SBN Double Circuit Ball Nut

125 bearing balls per circuit - 250 total per nut

PRODUCT SPECIFICATIONS	RH	LH
Dynamic Load (lbs.)	4,198	4,198
Static Load (lbs.)	44,030	44,030
Torque to Raise 1 lb. (in.-lb.)	.044	.044
Nut Weight (lbs.)	1.7	1.7
Ball Nut Number	SBN9587	SBN1990
Flange Part Number	FLG6754	FLG6754
Wiper Kit Part Number	WKB2654	WKB2654

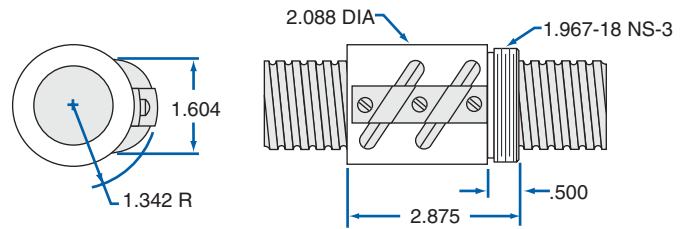

SEL Preload Ball Nut

125 bearing balls per circuit - 500 total per nut

PRODUCT SPECIFICATIONS	RH	LH
Dynamic Load (lbs.)	4,198	4,198
Static Load (lbs.)	44,030	44,030
Torque to Raise 1 lb. (in.-lb.)	.044	.044
Nut Weight (lbs.)	3.0	3.0
Preload (lbs.)	920	920
Ball Nut Number	SEL4271	SEL4573
Flange Part Number	FLG6754	FLG6754
Wiper Kit Part Number	WKB2654	WKB2654

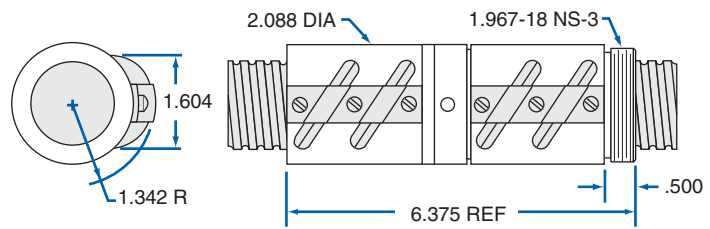

SAR Adjustable Preload Flanged Ball Nut

125 bearing balls per circuit - 500 total per nut

PRODUCT SPECIFICATIONS	RH	LH
Dynamic Load (lbs.)	4,198	—
Static Load (lbs.)	44,030	—
Torque to Raise 1 lb. (in.-lb.)	.044	—
Nut Weight (lbs.)	6.0	—
Preload (lbs.)	920	—
Ball Nut Number	SAR3043	—
Flange	INTEGRAL	—
Wiper Type	BRUSH	—

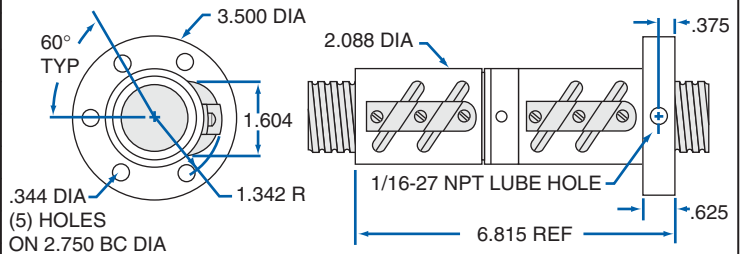

Flange - FLG6754

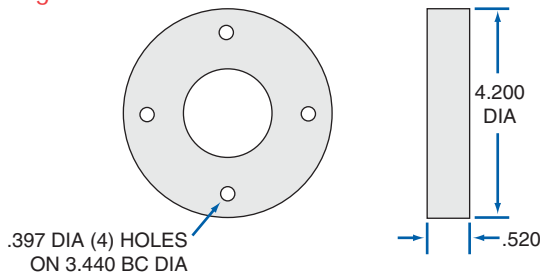

Brush Wiper Kit - WKB2654

2 wipers and 1 retainer

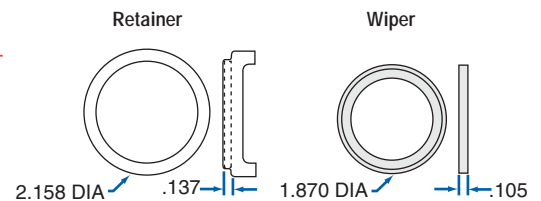

TWIN-LEAD SCREW

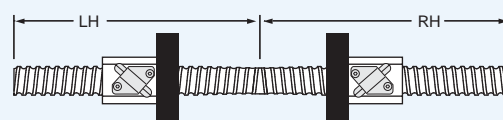

See page 148 for complete product details.

Standard Screw Lengths	PART NUMBERS	
	XPR RH	SGT RH
6 FT.	XPR15025R72	GT15025R72
10 FT.	—	GT15025R120
12 FT.	XPR15025R144	—

XPR custom cut lengths available up to 12',
SGT custom cut lengths available up to 10', contact Customer Service.

1500-0250 XPR and SGT

LEAD ACCURACY: XPR ± 0.001 in./ft. SGT ± 0.0005 in./ft.

Single Start

- 1.500** Ball Circle Diameter
- 0.250** Lead
- 1.320** Root Diameter
- 0.156** Nominal Ball Diameter
- 5.41** Screw Weight (lbs./ft.)

PRN Preloaded Ball Nut with Wipers		95 bearing balls per circuit - 380 total per nut
PRODUCT SPECIFICATIONS	RH	
Dynamic Load (lbs.)	5,075	
Static Load (lbs.)	27,250	
Torque to Raise 1 lb. (in.-lb.)	.044	
Spring Rate x 10 ⁶ (lb./in.)	5.0	
Nut Weight (lbs.)	2.7	
Ball Nut Number	PRN10113	
Flange Part Number	—	
Wiper Type	ELASTOMER	

SSN Preloaded Flanged Ball Nut with Wipers		95 bearing balls per circuit - 380 total per nut
PRODUCT SPECIFICATIONS	RH	
Dynamic Load (lbs.)	5,075	
Static Load (lbs.)	27,250	
Torque to Raise 1 lb. (in.-lb.)	.044	
Spring Rate x 10 ⁶ (lb./in.)	5.0	
Nut Weight (lbs.)	3.8	
Ball Nut Number	SSN0400	
Flange	INTEGRAL	
Wiper Type	ELASTOMER	

SAG Adjustable Preload Flanged Ball Nut		95 bearing balls per circuit - 380 total per nut
PRODUCT SPECIFICATIONS	RH	
Dynamic Load (lbs.)	5,950	
Static Load (lbs.)	44,030	
Torque to Raise 1 lb. (in.-lb.)	.044	
Preload (lbs.)	920	
Nut Weight (lbs.)	6	
Ball Nut Number	SAG0705	
Flange	INTEGRAL	
Wiper Type	BRUSH	

BALL SCREW ASSEMBLIES

These assemblies are shipped with screw, nut, flange, and bearing supports.

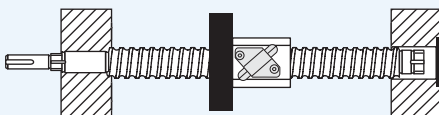

See page 145 for complete product details.

EZZE-MOUNT™ END BEARING SUPPORTS

A convenient solution for mounting ball screw assemblies.

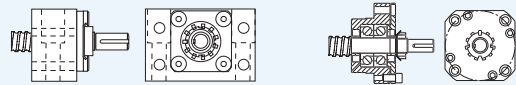

Single or Double Bearing
Universal Mount

Single or Double Bearing
Flange Mount

See page 214 for complete product details.

1500-0473 SRT

LEAD ACCURACY: ± 0.004 in./ft.

Single Start

- 1.500** Ball Circle Diameter
- 0.473** Lead*
- 1.140** Root Diameter
- 0.344** Nominal Ball Diameter
- 4.47** Screw Weight (lbs./ft.)

* actual lead 0.47368

Standard Screw Lengths	PART NUMBERS
	RH
4 FT.	SRT9610
8 FT.	SRT9127
12 FT.	SRT9624
16 FT.	SRT0435
20 FT.	SRT0597

Custom cut lengths available up to 24'. For longer lengths contact Customer Service.

INCH BALL SCREW AND NUT TECHNICAL DATA

SBN Double Circuit Ball Nut

43 bearing balls per circuit - 86 total per nut

PRODUCT SPECIFICATIONS	RH
Dynamic Load (lbs.)	10,050
Static Load (lbs.)	57,770
Torque to Raise 1 lb. (in.-lb.)	.084
Nut Weight (lbs.)	3.9
Ball Nut Number	SBN7513
Flange Part Number	FLG7573
Wiper Kit Part Number	WKB2655

SBN Keyed Double Circuit Ball Nut

43 bearing balls per circuit - 86 total per nut

PRODUCT SPECIFICATIONS	RH
Dynamic Load (lbs.)	10,050
Static Load (lbs.)	57,770
Torque to Raise 1 lb. (in.-lb.)	.084
Nut Weight (lbs.)	3.9
Ball Nut Number	SBN8345
Flange Part Number	—
Wiper Kit Part Number	WKB2656

Flange - FLG7573

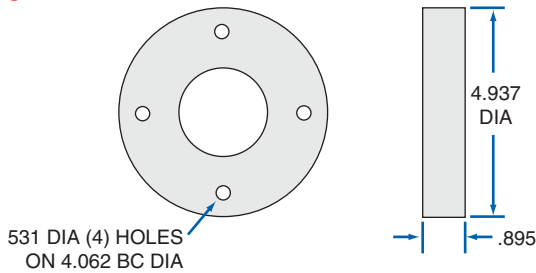

Brush Wiper Kit - WKB2656

2 wipers and 2 retainers

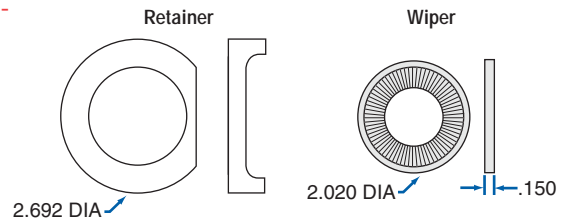

Brush Wiper Kit - WKB2655

2 wipers, 1 retainer and 1 retaining ring

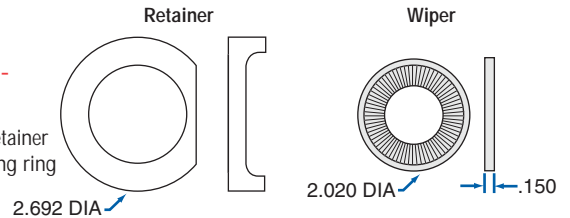

Standard Screw Lengths	PART NUMBERS	
	RH	
4 FT.	SRT9994	
8 FT.	SRT9995	
12 FT.	SRT9996	
16 FT.	SRT9997	

Custom cut lengths available up to 24'. For longer lengths contact Customer Service.

1500-0500 SRT

LEAD ACCURACY: ±0.004 in./ft.

Single Start

- 1.500** Ball Circle Diameter
- 0.500** Lead
- 1.174** Root Diameter
- 0.312** Nominal Ball Diameter
- 5.25** Screw Weight (lbs./ft.)

SBN Double Circuit Ball Nut		65 bearing balls per circuit - 130 total per nut
PRODUCT SPECIFICATIONS	RH	
Dynamic Load (lbs.)	12,320	
Static Load (lbs.)	97,696	
Torque to Raise 1 lb. (in.-lb.)	.088	
Nut Weight (lbs.)	5.2	
Ball Nut Number	SBN1550	
Flange Part Number	FLG10060	
Wiper Type	BRUSH	

SEL Adjustable Preload Ball Nut		65 bearing balls per circuit - 260 total per nut
PRODUCT SPECIFICATIONS	RH	
Dynamic Load (lbs.)	12,320	
Static Load (lbs.)	97,696	
Torque to Raise 1 lb. (in.-lb.)	.088	
Preload Range (lbs.)	1,232-3,696	
Nut Weight (lbs.)	11.7	
Ball Nut Number	SEL10072	
Flange Part Number	FLG10060	
Wiper Type	BRUSH	

Flange - FLG10060

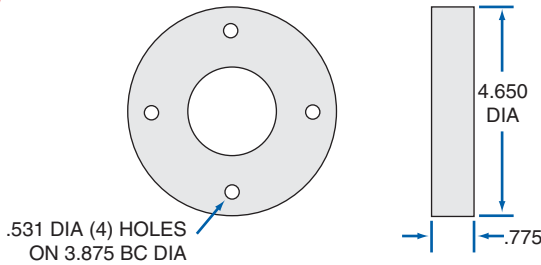

BALL SCREW ASSEMBLIES

These assemblies are shipped with screw, nut, flange, and bearing supports.

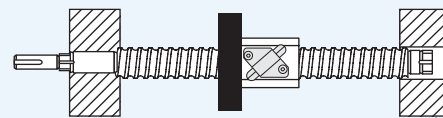

See page 145 for complete product details.

EZZE-MOUNT™ END BEARING SUPPORTS

A convenient solution for mounting ball screw assemblies.

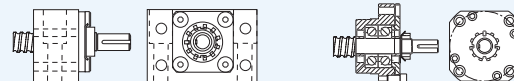

Single or Double Bearing
Universal Mount

Single or Double Bearing
Flange Mount

See page 214 for complete product details.



LUBRICANT

Prolong ball screw and nut performance with this special lubricant.

E-900 12oz. Spray or 32oz. Liquid
See page 95 for complete product details.



1500-0500 XPR

LEAD ACCURACY: ± 0.001 in./ft.

Single Start

- 1.500** Ball Circle Diameter
- 0.500** Lead
- 1.174** Root Diameter
- 0.312** Nominal Ball Diameter
- 5.3** Screw Weight (lbs./ft.)

Standard Screw Lengths	PART NUMBERS
	XPR RH
6 FT.	XPR15050R72
12 FT.	XPR15050R144
Custom cut lengths available up to 12', contact Customer Service.	

INCH BALL SCREW AND NUT TECHNICAL DATA

PRN Preloaded Ball Nut with Wipers

48 bearing balls per circuit - 96 total per nut

PRODUCT SPECIFICATIONS	RH
Dynamic Load (lbs.)	5,650
Static Load (lbs.)	35,522
Torque to Raise 1 lb. (in.-lb.)	.088
Spring Rate x 10 ⁶ (lb./in.)	5.2
Nut Weight (lbs.)	3.5
Ball Nut Number	PRN10114
Flange Part Number	—
Wiper Type	ELASTOMER

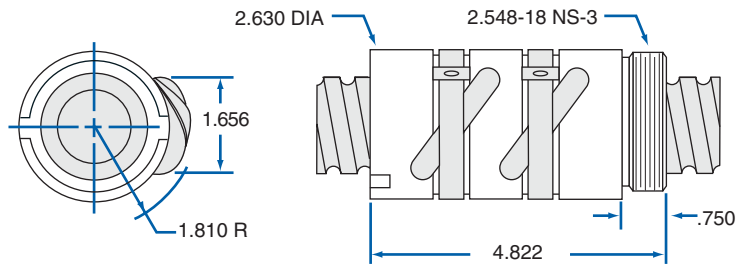

1500-0500 SGT

LEAD ACCURACY: ± 0.0005 in./ft.

Single Start

- 1.500** Ball Circle Diameter
- 0.500** Lead
- 1.230** Root Diameter
- 0.250** Nominal Ball Diameter
- 5.3** Screw Weight (lbs./ft.)

Standard Screw Lengths	PART NUMBERS
	SGT RH
6 FT.	GT15050R72
10 FT.	GT15050R120
Custom cut lengths available up to 10', contact Customer Service.	

SSN Preloaded Flanged Ball Nut with Wipers

48 bearing balls per circuit - 96 total per nut

PRODUCT SPECIFICATIONS	RH
Dynamic Load (lbs.)	4,250
Static Load (lbs.)	35,770
Torque to Raise 1 lb. (in.-lb.)	.088
Spring Rate x 10 ⁶ (lb./in.)	5.0
Nut Weight (lbs.)	3.8
Ball Nut Number	SSN0401
Flange	INTEGRAL
Wiper Type	ELASTOMER

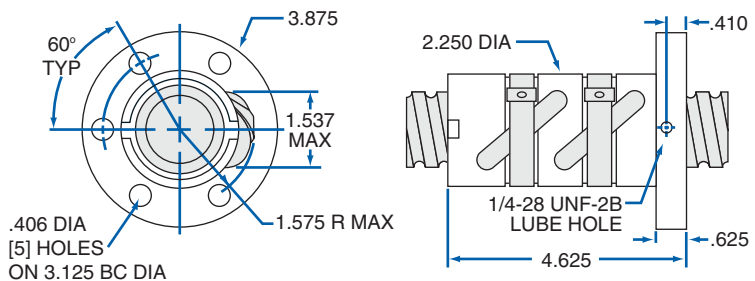

BALL SCREW ASSEMBLIES

These assemblies are shipped with screw, nut, flange, and bearing supports.

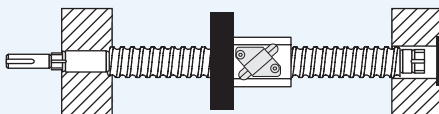

See page 145 for complete product details.

EZZE-MOUNT™ END BEARING SUPPORTS

A convenient solution for mounting ball screw assemblies.

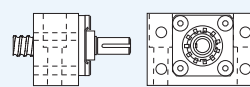

Single or Double Bearing
Universal Mount

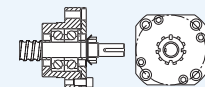

Single or Double Bearing
Flange Mount

See page 214 for complete product details.

Standard Screw Lengths	PART NUMBERS	
	RH	LH
4 FT.	SRT8837	SRT1991
8 FT.	SRT8845	SRT1992
12 FT.	SRT8853	SRT2203
16 FT.	SRT0436	SRT0437
20 FT.	SRT0598	SRT0615

Custom cut lengths available up to 24'. For longer lengths contact customer service.

1500-1000 SRT

LEAD ACCURACY: ±0.004 in./ft.

Double Start

- 1.500** Ball Circle Diameter
- 1.000** Lead
- 1.140** Root Diameter
- 0.344** Nominal Ball Diameter
- 4.47** Screw Weight (lbs./ft.)

SBN Double Circuit Ball Nut			30 bearing balls per circuit - 60 total per nut
PRODUCT SPECIFICATIONS	RH	LH	
Dynamic Load (lbs.)	7,560	7,560	
Static Load (lbs.)	34,662	34,662	
Torque to Raise 1 lb. (in.-lb.)	.177	.177	
Nut Weight (lbs.)	3.9	3.9	
Ball Nut Number	SBN8280	SBN1995	
Flange Part Number	FLG7777	FLG7777	
Wiper Kit Part Number	WKB2657	WKB2657	

SEL Adjustable Preload Ball Nut			30 bearing balls per circuit - 60 total per nut
PRODUCT SPECIFICATIONS	RH	LH	
Dynamic Load (lbs.)	7,560	7,560	
Static Load (lbs.)	34,662	34,662	
Torque to Raise 1 lb. (in.-lb.)	.177	.177	
Preload Range (lbs.)	1,650	1,650	
Nut Weight (lbs.)	9.1	9.1	
Ball Nut Number	SEL0698	SEL0697	
Flange Part Number	FLG7777	FLG7777	
Wiper Kit Part Number	WKB2657	WKB2657	

Flange - FLG7777

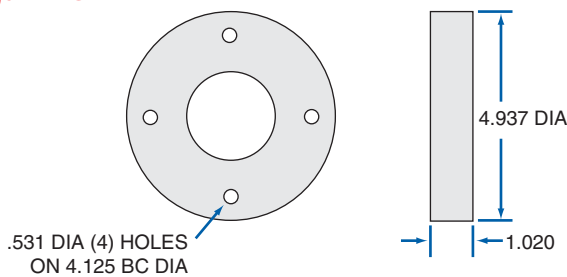

Brush Wiper Kit - WKB2657

2 wipers and 1 retainer

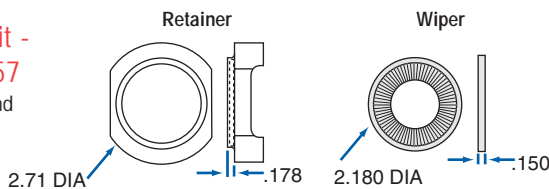

BALL SCREW ASSEMBLIES

These assemblies are shipped with screw, nut, flange, and bearing supports.

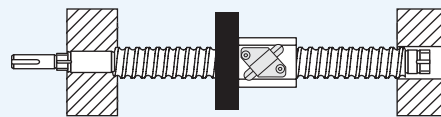

See page 145 for complete product details.

TWIN-LEAD SCREW

Single piece twin-lead screws offer opposing motion through a single drive system.

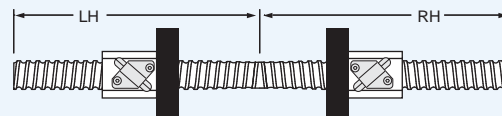

See page 148 for complete product details.

1500-1875 SRT

LEAD ACCURACY: ± 0.004 in./ft.

Four Start

- 1.500** Ball Circle Diameter
- 1.875** Lead
- 1.188** Root Diameter
- 0.281** Nominal Ball Diameter
- 5.25** Screw Weight (lbs./ft.)

Standard Screw Lengths	PART NUMBERS
	RH
4 FT.	SRT7702
8 FT.	SRT7710
12 FT.	SRT7718
16 FT.	SRT0438
20 FT.	SRT0599

Custom cut lengths available up to 24'. For longer lengths contact Customer Service.

INCH BALL SCREW AND NUT TECHNICAL DATA

SBN Double Circuit Ball Nut

44 bearing balls per circuit - 88 total per nut

PRODUCT SPECIFICATIONS	RH
Dynamic Load (lbs.)	7,242
Static Load (lbs.)	29,895
Torque to Raise 1 lb. (in.-lb.)	.332
Nut Weight (lbs.)	4.2
Ball Nut Number	SBN7654
Flange Part Number	FLG7777
Wiper Kit Part Number	WKB2657

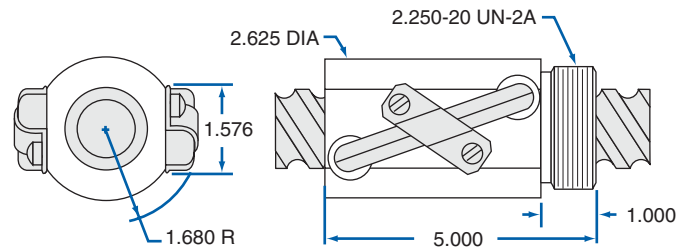

SEL Adjustable Preload Integral Wipers Ball Nut

44 bearing balls per circuit - 176 total per nut

PRODUCT SPECIFICATIONS	RH
Dynamic Load (lbs.)	7,242
Static Load (lbs.)	29,895
Torque to Raise 1 lb. (in.-lb.)	.332
Preload Range (lbs.)	1,650
Nut Weight (lbs.)	9.9
Ball Nut Number	SEL4272
Flange Part Number	FLG7777
Wiper Kit Part Number	WKB2657

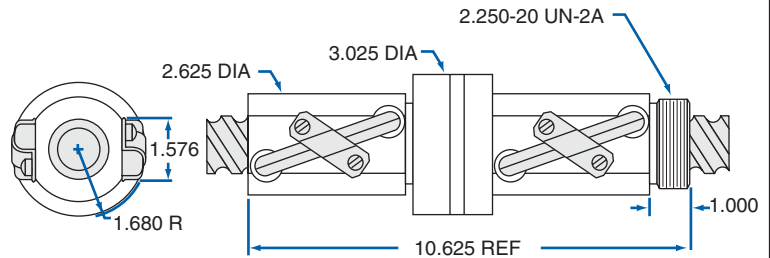

Flange - FLG7777

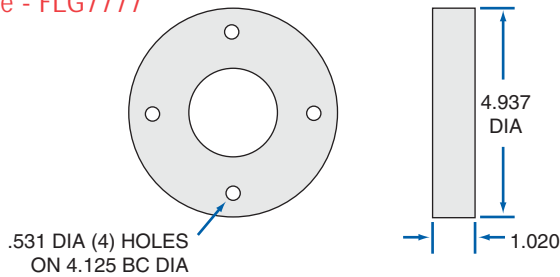

Brush Wiper Kit - WKB2657

2 wipers and
1 retainer

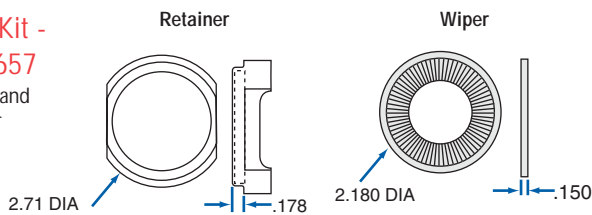

BALL SCREW ASSEMBLIES

These assemblies are shipped with screw, nut, flange, and bearing supports.

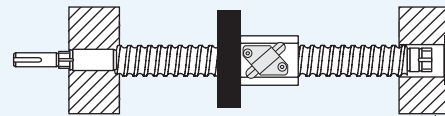

See page 145 for complete product details.

EZZE-MOUNT™ END BEARING SUPPORTS

A convenient solution for mounting ball screw assemblies.

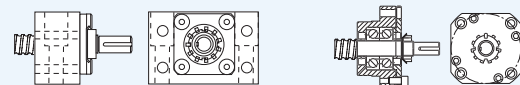

Single or Double Bearing
Universal Mount

Single or Double Bearing
Flange Mount

See page 214 for complete product details.

Standard Screw Lengths	PART NUMBERS
	SGT RH
6 FT.	GT17525R72
Custom cut lengths available up to 6', contact Customer Service.	

1750-0250 SGT

LEAD ACCURACY: ±0.0005 in./ft.

Single Start

- 1.750** Ball Circle Diameter
- 0.250** Lead
- 1.613** Root Diameter
- 0.156** Nominal Ball Diameter
- 7.56** Screw Weight (lbs./ft.)

SSN Preloaded Flanged Ball Nut with Wipers		112 bearing balls per circuit - 448 total per nut	
PRODUCT SPECIFICATIONS	RH		
Dynamic Load (lbs.)	5,600		
Static Load (lbs.)	32,500		
Torque to Raise 1 lb. (in.-lb.)	.044		
Spring Rate x 10 ⁶ (lb./in.)	5.8		
Nut Weight (lbs.)	3.25		
Ball Nut Number	SSN10277		
Flange	INTEGRAL		
Wiper Type	ELASTOMER		

BALL SCREW ASSEMBLIES

These assemblies are shipped with screw, nut, flange, and bearing supports.

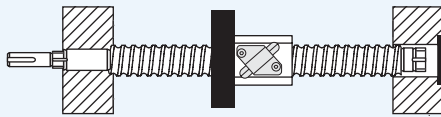

See page 145 for complete product details.

EZZE-MOUNT™ END BEARING SUPPORTS

A convenient solution for mounting ball screw assemblies.

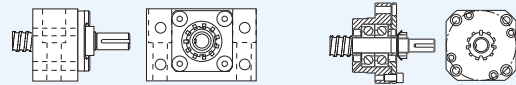

Single or Double Bearing
Universal Mount

Single or Double Bearing
Flange Mount

See page 214 for complete product details.

END MACHINING

Machining for Nook standard ends or custom requirement available.

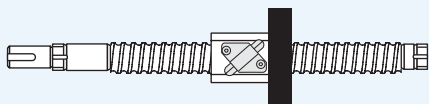

See page 212 for complete product details.

LUBRICANT

Prolong ball screw and nut performance with this special lubricant.



E-900 12oz. Spray or 32oz. Liquid
See page 95 for complete product details.

INCH BALL SCREW AND NUT TECHNICAL DATA

2000-0200 SGT

LEAD ACCURACY: ± 0.0005 in./ft.

Single Start

- 2.000** Ball Circle Diameter
- 0.200** Lead
- 1.849** Root Diameter
- 0.141** Nominal Ball Diameter
- 9.9** Screw Weight (lbs./ft.)

Standard Screw Lengths	PART NUMBERS	
	SGT RH	SGT LH
6 FT.	GT20020R72	GT20020L48
10 FT.	GT20020R120	GT20020L120

Custom cut lengths available up to 10', contact Customer Service.

SSN Preloaded Flanged Ball Nut with Wipers

138 bearing balls per circuit - 828 total per nut

PRODUCT SPECIFICATIONS	RH	LH
Dynamic Load (lbs.)	6,181	6,181
Static Load (lbs.)	65,903	65,903
Torque to Raise 1 lb. (in.-lb.)	.035	.035
Spring Rate x 10 ⁶ (lb./in.)	6.50	6.50
Nut Weight (lbs.)	4.5	4.5
Ball Nut Number	SSN0396	SSN10267
Flange	INTEGRAL	INTEGRAL
Wiper Type	ELASTOMER	ELASTOMER

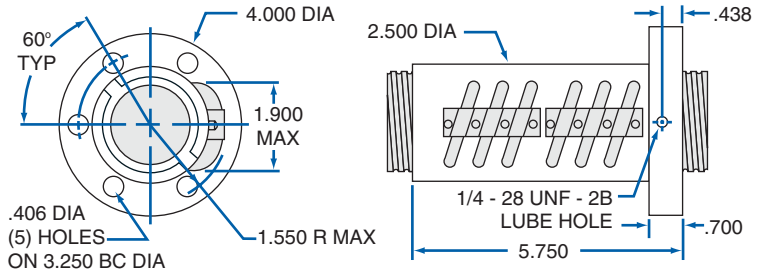

INCH BALL SCREW AND NUT TECHNICAL DATA

2000-0400 SGT

LEAD ACCURACY: ± 0.0005 in./ft.

Single Start

- 2.000** Ball Circle Diameter
- 0.400** Lead
- 1.742** Root Diameter
- 0.250** Nominal Ball Diameter
- 9.4** Screw Weight (lbs./ft.)

Standard Screw Lengths	PART NUMBERS	
	SGT RH	
6 FT.	GT20040R72	
10 FT.	GT20040R120	

Custom cut lengths available up to 10', contact Customer Service.

SSN Preloaded Flanged Ball Nut with Wipers

79 bearing balls per circuit - 316 total per nut

PRODUCT SPECIFICATIONS	RH
Dynamic Load (lbs.)	12,830
Static Load (lbs.)	72,360
Torque to Raise 1 lb. (in.-lb.)	.070
Spring Rate x 10 ⁶ (lb./in.)	11.00
Nut Weight (lbs.)	6.7
Ball Nut Number	SSN10005
Flange	INTEGRAL
Wiper Type	ELASTOMER

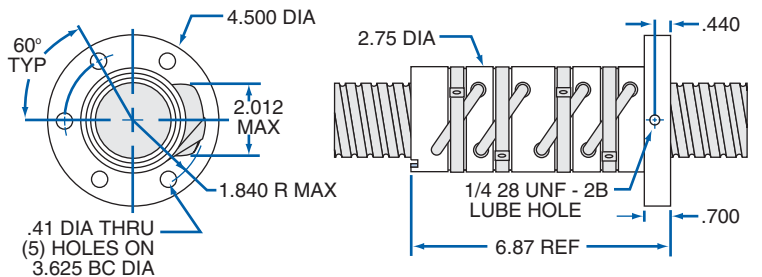

BALL SCREW ASSEMBLIES

These assemblies are shipped with screw, nut, flange, and bearing supports.

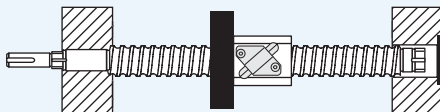

See page 145 for complete product details.

EZZE-MOUNT™ END BEARING SUPPORTS

A convenient solution for mounting ball screw assemblies.

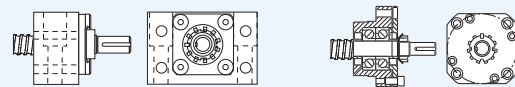

Single or Double Bearing
Universal Mount

Single or Double Bearing
Flange Mount

See page 214 for complete product details.

Standard Screw Lengths	PART NUMBERS	
	RH	LH
4 FT.	SRT5051	SRT4001
8 FT.	SRT5059	SRT4002
12 FT.	SRT5067	SRT4003
16 FT.	SRT0439	SRT0440
20 FT.	SRT0600	SRT0602

Custom cut lengths available up to 24'. For longer lengths contact customer service.

2250-0500 SRT

LEAD ACCURACY: ± 0.004 in./ft.

Single Start

- 2.250** Ball Circle Diameter
- 0.500** Lead
- 1.850** Root Diameter
- 0.375** Nominal Ball Diameter
- 10.9** Screw Weight (lbs./ft.)

SBN Double Circuit Ball Nut			78 bearing balls per circuit - 156 total per nut
PRODUCT SPECIFICATIONS	RH	LH	
Dynamic Load (lbs.)	21,306	21,306	
Static Load (lbs.)	142,660	142,660	
Torque to Raise 1 lb. (in.-lb.)	.088	.088	
Nut Weight (lbs.)	9.0	9.0	
Ball Nut Number	SBN7516	SBN4000	
Flange Part Number	FLG7574	FLG7574	
Wiper Kit Part Number	WKB2659/WKF3890	WKB2659/WKF0456	

SBN Keyed Double Circuit Ball Nut			78 bearing balls per circuit - 156 total per nut
PRODUCT SPECIFICATIONS	RH	LH	
Dynamic Load (lbs.)	21,306	21,306	
Static Load (lbs.)	142,660	142,660	
Torque to Raise 1 lb. (in.-lb.)	.088	.088	
Nut Weight (lbs.)	8.2	8.2	
Ball Nut Number	SBN8346	SBN4005	
Flange Part Number	—	—	
Wiper Kit Part Number	WKB2659	WKB2659	

SAR Preloaded Flanged Ball Nut or SEL Preloaded Ball Nut				78 bearing balls per circuit - 312 total per nut
PRODUCT SPECIFICATIONS	SAR RH	SEL RH*	SEL LH*	
Dynamic Load (lbs.)	21,306	21,306	21,306	
Static Load (lbs.)	142,660	142,660	142,660	
Torque to Raise 1 lb. (in.-lb.)	.088	.088	.088	
Nut Weight (lbs.)	24.2	22.2	22.2	
Preload Range (lbs.)	2,130-6,390	2,130-6,390	2,130-6,390	
Ball Nut Number	SAR3044	SEL10084	SEL10090	
Flange Part Number	INCLUDED	FLG7574	FLG7574	
Wiper Type/Kit Part Number	BRUSH	WKB2659	WKF3890	

* No Integral Flange - Threaded End same as SBN7516/SBN4000

Flange - FLG7574

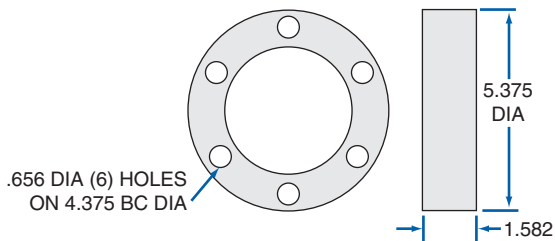

Felt Wiper Kit - WKF3890

2 wipers and 2 retainers

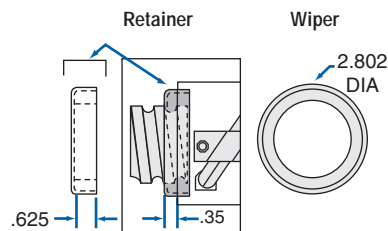

Brush Wiper Kit - WKB2659

2 wipers and 2 retainer rings

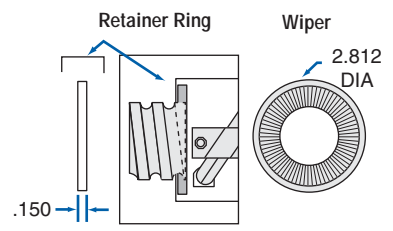

2250-0500 XPR and SGT

LEAD ACCURACY: XPR ± 0.001 in./ft. SGT ± 0.0005 in./ft.

Single Start

- 2.250** Ball Circle Diameter
- 0.500** Lead
- 1.850** Root Diameter
- 0.375** Nominal Ball Diameter
- 10.8** Screw Weight (lbs./ft.)

Standard Screw Lengths	PART NUMBERS	
	XPR RH	SGT RH
6 FT.	XPR22550R72	GT22550R72
10 FT.	—	GT22550R120
12 FT.	XPR22550R144	—

XPR custom cut lengths available up to 12',
SGT custom cut lengths available up to 10', contact Customer Service.

INCH BALL SCREW AND NUT TECHNICAL DATA

PRN Preloaded Ball Nut with Wipers		99 bearing balls per circuit - 198 total per nut
PRODUCT SPECIFICATIONS	RH	
Dynamic Load (lbs.)	20,106	
Static Load (lbs.)	108,325	
Torque to Raise 1 lb. (in.-lb.)	.088	
Spring Rate x 10 ⁶ (lb./in.)	7.25	
Nut Weight (lbs.)	10.5	
Ball Nut Number	PRN10089	
Flange Part Number	—	
Wiper Type	ELASTOMER	

SSN Preloaded Flanged Ball Nut with Wipers		99 bearing balls per circuit - 198 total per nut
PRODUCT SPECIFICATIONS	RH	
Dynamic Load (lbs.)	20,106	
Static Load (lbs.)	108,325	
Torque to Raise 1 lb. (in.-lb.)	.088	
Spring Rate x 10 ⁶ (lb./in.)	7.25	
Nut Weight (lbs.)	15.2	
Ball Nut Number	SSN0402	
Flange	INTEGRAL	
Wiper Type	ELASTOMER	

SAG Adjustable Preload Flanged Ball Nut		99 bearing balls per circuit - 396 total per nut
PRODUCT SPECIFICATIONS	RH	
Dynamic Load (lbs.)	30,000	
Static Load (lbs.)	142,660	
Torque to Raise 1 lb. (in.-lb.)	.088	
Preload (lbs.)	2,130-6,390	
Nut Weight (lbs.)	24.2	
Ball Nut Number	SAG0706	
Flange	INCLUDED	
Wiper Type	BRUSH	

BALL SCREW ASSEMBLIES

These assemblies are shipped with screw, nut, flange, and bearing supports.

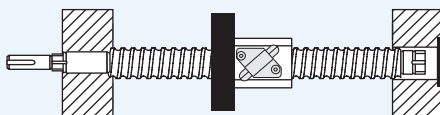

See page 145 for complete product details.

EZZE-MOUNT™ END BEARING SUPPORTS

A convenient solution for mounting ball screw assemblies.

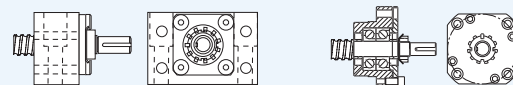

Single or Double Bearing
Universal Mount

Single or Double Bearing
Flange Mount

See page 214 for complete product details.

Standard Screw Lengths	PART NUMBERS
	RH
4 FT.	SRT4556
8 FT.	SRT4557
12 FT.	SRT4558
16 FT.	SRT0441
20 FT.	SRT0604

Custom cut lengths available up to 24'. For longer lengths contact Customer Service.

2250-1000 SRT

LEAD ACCURACY: ±0.004 in./ft.

Double Start

- 2.250** Ball Circle Diameter
- 1.000** Lead
- 1.850** Root Diameter
- 0.375** Nominal Ball Diameter
- 10.9** Screw Weight (lbs./ft.)

SBN Double Circuit Ball Nut		83 bearing balls per circuit - 166 total per nut
PRODUCT SPECIFICATIONS	RH	
Dynamic Load (lbs.)	26,538	
Static Load (lbs.)	142,660	
Torque to Raise 1 lb. (in.-lb.)	.177	
Nut Weight (lbs.)	9.0	
Ball Nut Number	SBN4555	
Flange Part Number	FLG7574	
Wiper Kit Part Number	WKB2659/WKF0457	

SAR Preloaded Integral Flange Ball Nut		83 bearing balls per circuit - 332 total per nut
PRODUCT SPECIFICATIONS	RH	
Dynamic Load (lbs.)	26,538	
Static Load (lbs.)	142,660	
Torque to Raise 1 lb. (in.-lb.)	.177	
Nut Weight (lbs.)	24.2	
Preload Range (lbs.)	2,650-7,960	
Ball Nut Number	SAR2210	
Flange	INCLUDED	
Wiper Type	BRUSH	

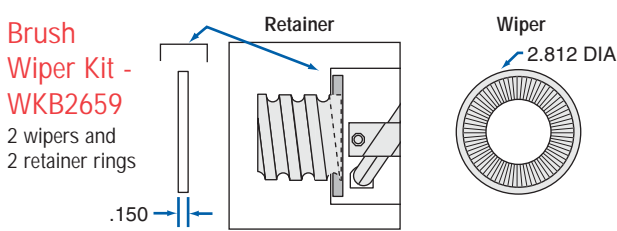
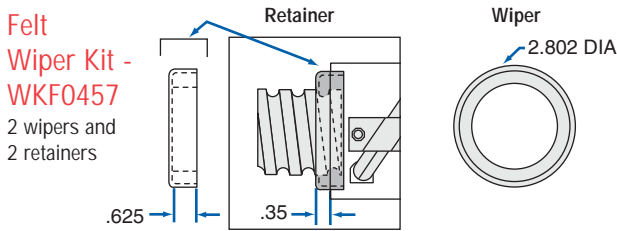
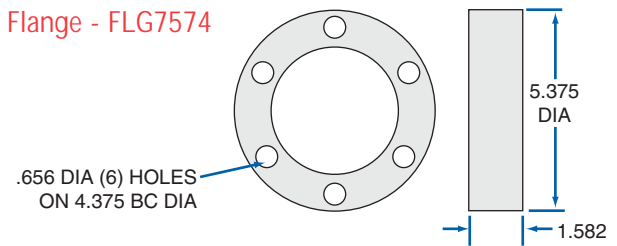

BALL SCREW ASSEMBLIES

These assemblies are shipped with screw, nut, flange, and bearing supports.

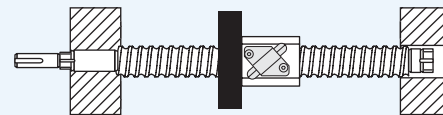

See page 145 for complete product details.

EZZE-MOUNT™ END BEARING SUPPORTS

A convenient solution for mounting ball screw assemblies.

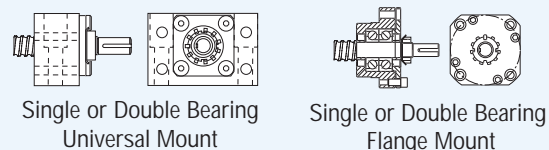

See page 214 for complete product details.

2500-0250 SRT & SGT

LEAD ACCURACY: ± 0.004 in./ft.

Single Start

- 2.500** Ball Circle Diameter
- 0.250** Lead
- 2.320** Root Diameter-SRT
- 2.333** Root Diameter-SGT
- 0.156** Nominal Ball Diameter
- 15.45** Screw Weight (lbs./ft.)

Standard Screw Lengths	PART NUMBERS		
	SRT - RH	SRT - LH	SGT - RH
4 FT.	SRT3255	SRT0400	—
6 FT.	—	—	GT25025R72
8 FT.	SRT3256	SRT0401	—
12 FT.	SRT3257	SRT0402	GT25025R144
16 FT.	SRT0442	SRT0403	—
20 FT.	SRT0606	SRT0404	—

Custom cut lengths available up to 24'. For longer lengths contact customer service.

INCH BALL SCREW AND NUT TECHNICAL DATA

SBN Triple Circuit Ball Nut

158 bearing balls per circuit - 474 total per nut

PRODUCT SPECIFICATIONS	RH	LH
Dynamic Load (lbs.)	6,315	6,315
Static Load (lbs.)	81,938	81,938
Torque to Raise 1 lb. (in.-lb.)	.044	.044
Nut Weight (lbs.)	4.7	4.7
Ball Nut Number	SBN3243	SBN10329
Flange Part Number	FLG3263	FLG3263
Wiper Kit Part Number	WKB3324	WKB3324

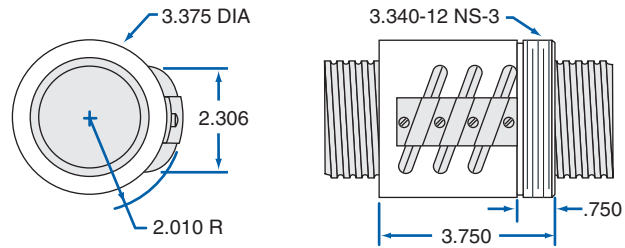

SAR Preloaded Integral Flange Ball Nut

SAG Adjustable Preload Integral Flange Ball Nut

158 bearing balls per circuit - 948 total per nut

PRODUCT SPECIFICATIONS	SAR RH	SAG RH
Dynamic Load (lbs.)	6,315	8,945
Static Load (lbs.)	81,938	93,165
Torque to Raise 1 lb. (in.-lb.)	.044	.044
Nut Weight (lbs.)	9.9	631-1,895
Preload Range (lbs.)	631-1,895	9.9
Ball Nut Number	SAR3242	SAG0707
Flange	INTEGRAL	INTEGRAL
Wiper Type	BRUSH	BRUSH

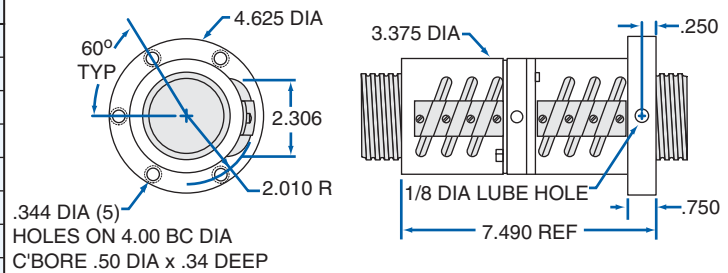

SSN Integral Preload Integral Flange Ball Nut

158 bearing balls per circuit - 948 total per nut

PRODUCT SPECIFICATIONS	RH
Dynamic Load (lbs.)	8,945
Static Load (lbs.)	93,165
Torque to Raise 1 lb. (in.-lb.)	.044
Spring Rate x 10 ⁶ (lb./in.)	8.00
Nut Weight (lbs.)	9.0
Ball Nut Number	SSN0403
Flange	INTEGRAL
Wiper Type	ELASTOMER

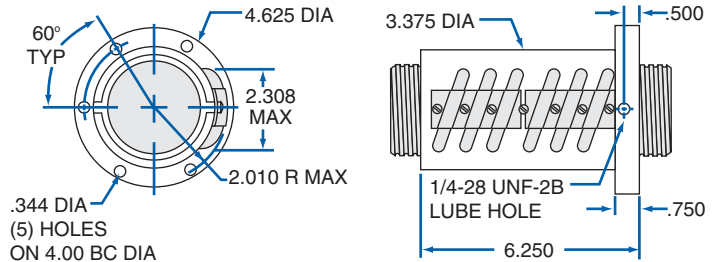

Flange - FLG3263

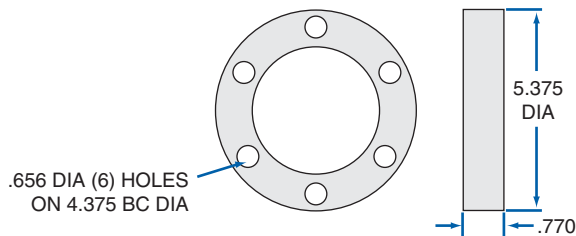

Brush Wiper Kit - WKB3324

2 wipers and 2 retainers

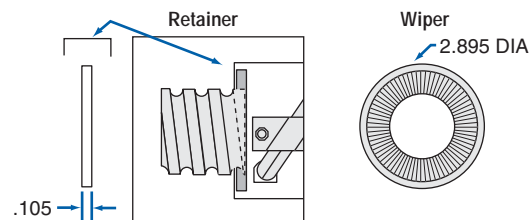

Standard Screw Lengths	PART NUMBERS
	RH
4 FT.	SRT0405
8 FT.	SRT0406
12 FT.	SRT0407
16 FT.	SRT0408
20 FT.	SRT0409

Custom cut lengths available up to 24'. For longer lengths contact Customer Service.

2500-0500 SRT

LEAD ACCURACY: ±0.004 in./ft.

Single Start

- 2.500** Ball Circle Diameter
- 0.500** Lead
- 2.116** Root Diameter
- 0.375** Nominal Ball Diameter
- 14.0** Screw Weight (lbs./ft.)

SBN Double Circuit Ball Nut

88 bearing balls per circuit - 176 total per nut

PRODUCT SPECIFICATIONS	RH
Dynamic Load (lbs.)	21,200
Static Load (lbs.)	186,000
Torque to Raise 1 lb. (in.-lb.)	.088
Nut Weight (lbs.)	12.7
Ball Nut Number	SBN10316
Flange Part Number	70600
Wiper Kit Part Number	—

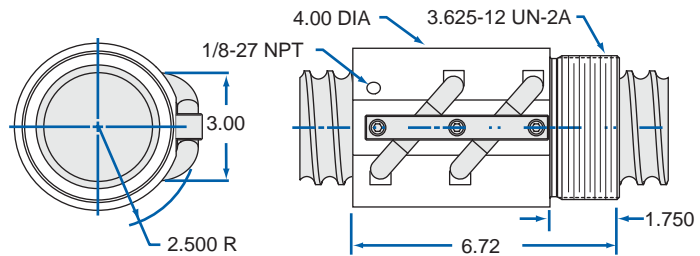

Flange - 70600

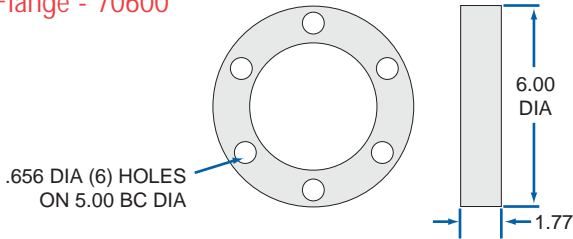

BALL SCREW ASSEMBLIES

These assemblies are shipped with screw, nut, flange, and bearing supports.

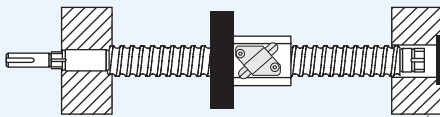

See page 145 for complete product details.

EZZE-MOUNT™ END BEARING SUPPORTS

A convenient solution for mounting ball screw assemblies.

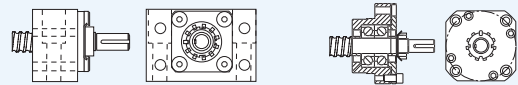

Single or Double Bearing
Universal Mount

Single or Double Bearing
Flange Mount

See page 214 for complete product details.

END MACHINING

Machining for Nook standard ends or custom requirement available.

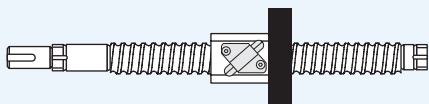

See page 212 for complete product details.

LUBRICANT

Prolong ball screw and nut performance with this special lubricant.



E-900 12oz. Spray or 32oz. Liquid
See page 95 for complete product details.

3000-0660 SRT

LEAD ACCURACY: ±0.008 in./ft.

Single Start

- 3.000** Ball Circle Diameter
- 0.660** Lead
- 2.480** Root Diameter
- 0.500** Nominal Ball Diameter
- 19.6** Screw Weight (lbs./ft.)

Standard Screw Lengths	PART NUMBERS	
	RH	LH
4 FT.	SRT5073	SRT0410
8 FT.	SRT5080	SRT0411
12 FT.	SRT5087	SRT0412
16 FT.	SRT0433	SRT0413
20 FT.	SRT0607	SRT0414

Custom cut lengths available up to 24'. For longer lengths contact customer service.

INCH BALL SCREW AND NUT TECHNICAL DATA

SBN Triple Circuit Ball Nut with Load-Lock Feature

57 bearing balls per circuit - 171 total per nut

PRODUCT SPECIFICATIONS	RH	RH w/safety thread	LH
Dynamic Load (lbs.)	44,316	44,316	44,316
Static Load (lbs.)	271,733	271,733	271,733
Torque to Raise 1 lb. (in.-lb.)	.117	.117	.117
Nut Weight (lbs.)	26	26	26
Ball Nut Number	SBN7519	SBN10202	SBN10257
Flange Part Number	FLG7575	FLG7575	FLG7575
Wiper Kit Part Number	WKB2661/ WKF3891	WKB2661/ WKF3891	WKB2661

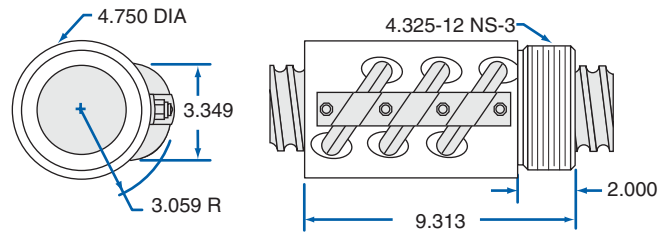

SBN Keyed Triple Circuit Ball Nut

57 bearing balls per circuit - 171 total per nut

PRODUCT SPECIFICATIONS	RH
Dynamic Load (lbs.)	44,316
Static Load (lbs.)	271,733
Torque to Raise 1 lb. (in.-lb.)	.117
Nut Weight (lbs.)	22
Ball Nut Number	SBN8347
Flange Part Number	—
Wiper Kit Part Number	—

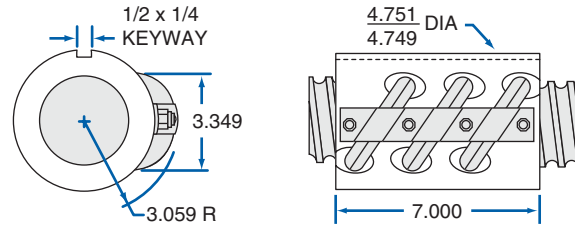

SAR Preloaded Flanged Ball Nut with Wipers or SEL Preloaded Ball Nut

57 bearing balls per circuit - 342 total per nut

PRODUCT SPECIFICATIONS	SAR RH	SEL RH*	SEL LH*
Dynamic Load (lbs.)	44,316	44,316	44,316
Static Load (lbs.)	271,733	271,733	271,733
Torque to Raise 1 lb. (in.-lb.)	.117	.117	.117
Nut Weight (lbs.)	67.5	51.5	51.5
Preload Range (lbs.)	4,430-13,295	4,430-13,295	4,430-13,295
Ball Nut Number	SAR3045	SEL10085	SEL10330
Flange Part Number	INCLUDED	FLG7575	FLG7575
Wiper Type/Kit Part Number	BRUSH	WKB2661/WKF3891	WKB2661

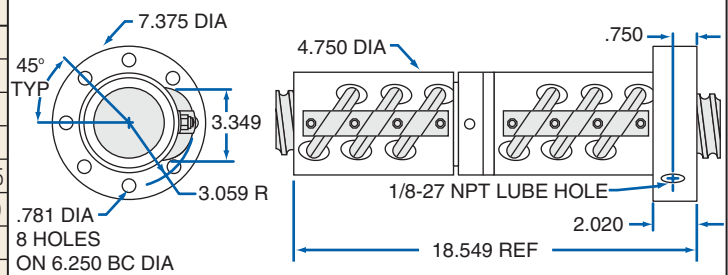

* No Integral Flange - Threaded End same as SBN4986

Flange - FLG7575

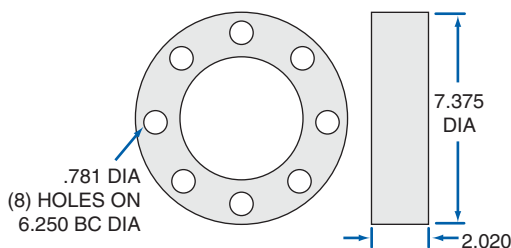

Felt Wiper Kit - WKF3891

2 wipers and 2 retainers

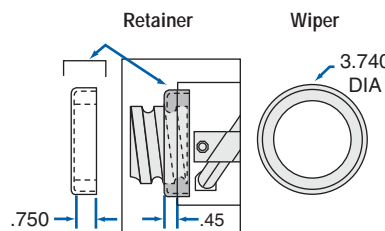

Brush Wiper Kit - WKB2661

2 wipers and 2 retainer rings

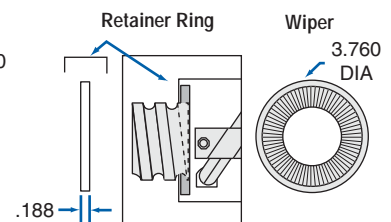

Standard Screw Lengths	PART NUMBERS	
	RH	
4 FT.	SRT4987	
8 FT.	SRT4988	
12 FT.	SRT4989	
16 FT.	SRT0444	
20 FT.	SRT0609	

Custom cut lengths available up to 24'. For longer lengths contact Customer Service.

3000-1500 SRT

LEAD ACCURACY: ±0.008 in./ft.

Double Start

- 3.000** Ball Circle Diameter
- 1.500** Lead
- 2.480** Root Diameter
- 0.500** Nominal Ball Diameter
- 19.3** Screw Weight (lbs./ft.)

SBN Double Circuit Ball Nut

83 bearing balls per circuit - 166 total per nut

PRODUCT SPECIFICATIONS	RH
Dynamic Load (lbs.)	53,646
Static Load (lbs.)	253,617
Torque to Raise 1 lb. (in.-lb.)	.266
Nut Weight (lbs.)	27.2
Ball Nut Number	SBN4986
Flange Part Number	FLG7575
Wiper Kit Part Number	WKB2661/WKF0458

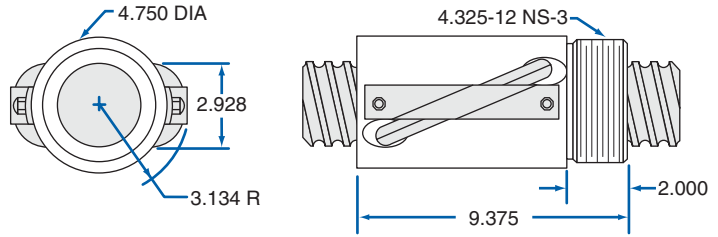

SAR Adjustable Preload Flanged Ball Nut with Wipers

83 bearing balls per circuit - 332 total per nut

PRODUCT SPECIFICATIONS	RH
Dynamic Load (lbs.)	53,646
Static Load (lbs.)	213,617
Torque to Raise 1 lb. (in.-lb.)	.266
Nut Weight (lbs.)	67.5
Preload Range (lbs.)	5,365-16,904
Ball Nut Number	SAR3015
Flange	INCLUDED
Wiper Type	BRUSH

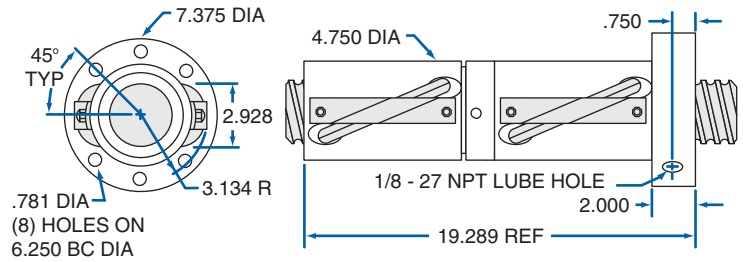

Flange - FLG7575

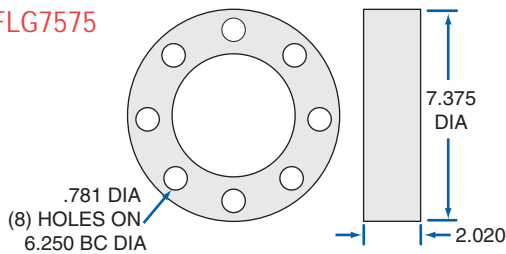

Felt Wiper Kit - WKF0458

2 wipers and 2 retainers

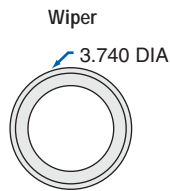
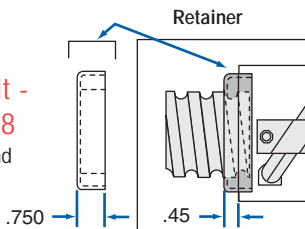

Brush Wiper Kit - WKB2661

2 wipers and 2 retainer rings

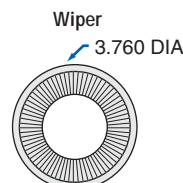
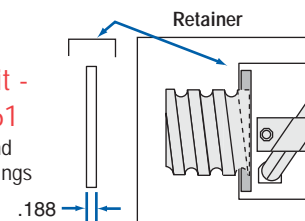

BALL SCREW ASSEMBLIES

These assemblies are shipped with screw, nut, flange, and bearing supports.

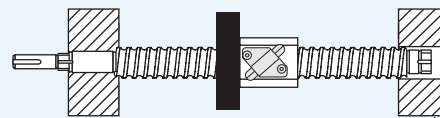

See page 145 for complete product details.

EZZE-MOUNT™ END BEARING SUPPORTS

A convenient solution for mounting ball screw assemblies.

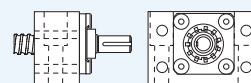

Single or Double Bearing
Universal Mount

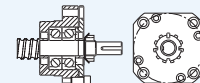

Single or Double Bearing
Flange Mount

See page 214 for complete product details.

4000-1000 SRT

LEAD ACCURACY: ±0.008 in./ft.

Single Start

- 4.000** Ball Circle Diameter
- 1.000** Lead
- 3.338** Root Diameter
- 0.625** Nominal Ball Diameter
- 34.4** Screw Weight (lbs./ft.)

Standard Screw Lengths	PART NUMBERS
	RH
4 FT.	SRT3259
8 FT.	SRT3260
12 FT.	SRT3261
16 FT.	SRT0624
20 FT.	SRT3262

Custom cut lengths available up to 24'. For longer lengths contact Customer Service.

INCH BALL SCREW AND NUT TECHNICAL DATA

SBN Triple Circuit Ball Nut with Load-Lock Feature

61 bearing balls per circuit - 183 total per nut

PRODUCT SPECIFICATIONS	RH
Dynamic Load (lbs.)	85,758
Static Load (lbs.)	476,970
Torque to Raise 1 lb. (in.-lb.)	.177
Nut Weight (lbs.)	53.5
Ball Nut Number	SBN3258
Flange Part Number	FLG3307
Wiper Kit Part Number	WKB3006/WKF4057

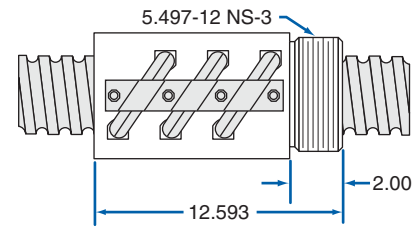
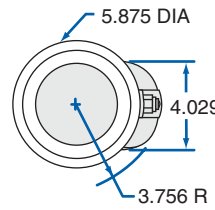

SAR Adjustable Preload Flanged Ball Nut with Wipers

61 bearing balls per circuit - 366 total per nut

PRODUCT SPECIFICATIONS	RH
Dynamic Load (lbs.)	85,758
Static Load (lbs.)	476,970
Torque to Raise 1 lb. (in.-lb.)	.177
Nut Weight (lbs.)	167.5
Preload Range (lbs.)	8,575-25,725
Ball Nut Number	SAR4625
Flange	INCLUDED
Wiper Type	BRUSH

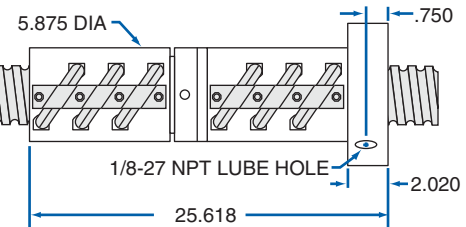
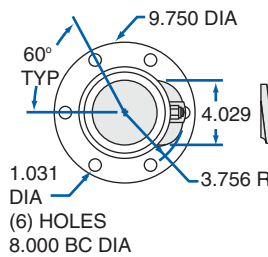

Flange - FLG3307

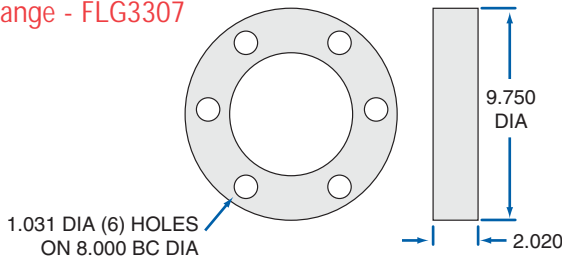

Felt Wiper Kit - WKF0457

2 wipers and
2 retainers

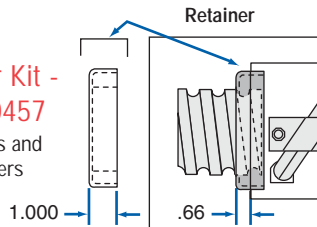

Wiper

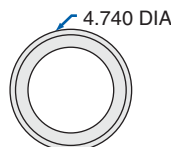

Brush Wiper Kit - WKB3306

2 wipers and
2 retainer rings

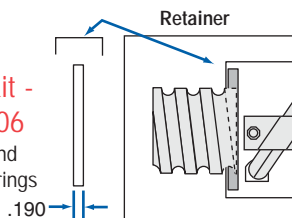

Wiper

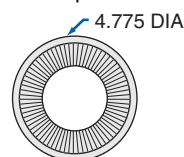

END MACHINING

Machining for Nook standard ends or custom requirement available.

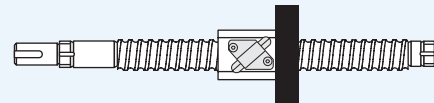

See page 212 for complete product details.

LUBRICANT

Prolong ball screw and nut performance with this special lubricant.



E-900 12oz. Spray or 32oz. Liquid
See page 95 for complete product details.

Standard Screw Lengths	RH
	NO STANDARD LENGTHS, ALL LENGTHS WILL BE QUOTED PER DRAWING

6000-1000 SRT

LEAD ACCURACY: ±0.002 in./ft.

Single Start

- 6.000** Ball Circle Diameter
- 1.000** Lead
- 5.232** Root Diameter
- 1.514** Nominal Ball Diameter
- 34.4** Screw Weight (lbs./ft.)

SBN Integral Return Ball Nut		25 bearing balls per circuit - 200 total per nut
PRODUCT SPECIFICATIONS	RH	
Dynamic Load (lbs.)	115,507	
Static Load (lbs.)	443,548	
Torque to Raise 1 lb. (in.-lb.)	.177	
Nut Weight (lbs.)	170	
Ball Nut Number	SBN10438	
Flange Part Number	FLG10437	
Wiper Kit Part Number	WKP10441	

SBN Internal Return Ball Nut with Integral Flange		25 bearing balls per circuit - 200 total per nut
PRODUCT SPECIFICATIONS	RH	
Dynamic Load (lbs.)	115,507	
Static Load (lbs.)	443,548	
Torque to Raise 1 lb. (in.-lb.)	.177	
Nut Weight (lbs.)	225	
Ball Nut Number	SBN10442	
Flange	INTEGRAL	
Wiper Type	PLASTIC	

Flange - FLG10437

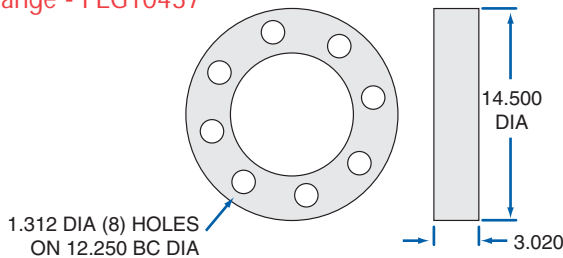

INCH BALL SCREW AND NUT TECHNICAL DATA

INCH QUICK REFERENCE: SRT, XPR AND SGT SCREWS AND NUTS

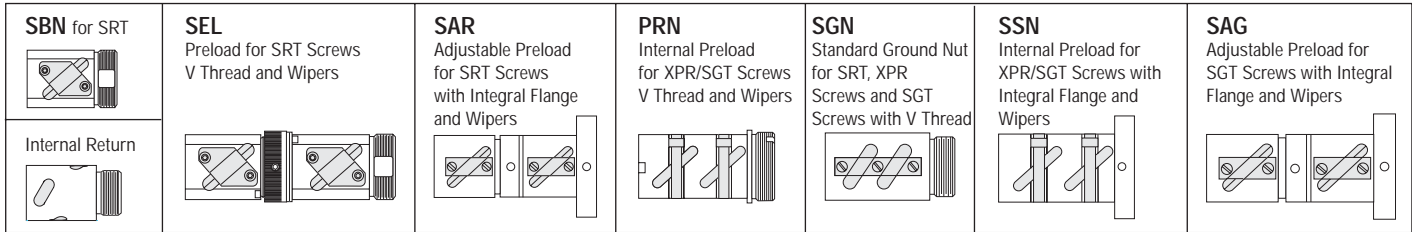

INCH BALL SCREW AND NUT TECHNICAL DATA

SCREW SELECTION										NUT SELECTION										Page Ref			
NOMINAL DIA-LEAD	Root Dia.	SRT 0.004"/ft			XPR 0.001"/ft		SGT 0.0005"/ft		LOAD RATING*		Torque To Raise 1lb. (in-lb)	SBN		SEL		SAR	PRN		SGN		SSN		SAG
		ALLOY RH	SS LH	SS RH	RH	LH	RH	LH	Static lbs.	Dynamic lbs.		ALLOY RH	SS LH	RH	LH		RH	LH			RH	LH	
0.375-0.125	0.300	●	●	●					1,415	136	0.022	●	●	●									99
0.500-0.200	0.405	●							7,071	973	0.035	●			●								100
0.500-0.500	0.360	●		●					4,131	786	0.088	●											101
0.631-0.200	0.500	●	●	●	●	●	●	●	6,384	815	0.035	●	●	●	●			●		●			102
0.631-0.500	0.500	●							5,565	960	0.088	●			●								106
0.631-1.000	1.000	●							2,580	620	0.177	●											106
0.750-0.200	0.602	●				●		●	8,569	1,100	0.035	●			●				●				107
0.750-0.500	0.602	●							17,425	2,723	0.088	●			●								109
0.875-0.200	0.735	●				●		●	18,063	1,942	0.035	●				●	●			●		●	110
1.000-0.200	0.865							●	13,073	1,565	0.035										●	●	112
1.000-0.250	0.820	●	●	●	●	●		●	13,913	1,612	0.044	●	●	●	●	●	●	●	●	●	●	●	113
1.000-0.500	0.820	●							25,250	2,142	0.088	●			●								116
1.000-1.000	0.820	●							11,925	2,370	0.177	●			●								117
1.150-0.200	1.015	●	●		●		●		28,180	3,894	0.035	●	●		●	●	●	●		●		●	118
1.171-0.413	0.870	●							22,917	3,894	0.073	●											120
1.250-0.200	1.115	●	●		●	●	●		34,688	3,336	0.035	●	●			●	●			●	●		121
1.250-0.500	1.050	●				●		●	17,235	2,745	0.088	●			●					●			123
1.500-0.200	1.349							●	45,073	4,745	0.035										●		125
1.500-0.250	1.320	●	●		●		●		44,030	4,198	0.044	●	●		●	●	●	●		●		●	126
1.500-0.473	1.140	●							57,770	10,050	0.084	●											128
1.500-0.500	1.174	●				●		●	97,696	12,320	0.088	●			●					●			129
1.500-1.000	1.140	●	●						34,662	7,560	0.177	●	●		●	●					●	●	131
1.500-1.875	1.188	●							28,895	7,242	0.332	●			●								132
1.750-0.250	1.613							●	32,500	5,600	0.044										●	●	133
2.000-0.200	1.849							●	65,903	6,181	0.035										●	●	134
2.000-0.400	1.742							●	72,360	12,830	0.070										●		134
2.250-0.500	1.850	●	●		●		●		142,660	21,306	0.088	●	●		●	●	●	●		●		●	135
2.250-1.000	1.850	●							142,660	26,538	0.177	●									●	●	137
2.500-0.250	2.320	●	●					●	81,938	6,315	0.044	●	●			●					●	●	138
2.500-0.500	2.116	●							186,000	21,200	0.088	●											139
3.000-0.660	2.480	●	●						271,733	44,316	0.117	●	●		●	●							140
3.000-1.500	2.480	●							253,617	53,646	0.266	●				●							141
4.000-1.000	3.338	●							253,167	53,646	0.177	●				●							142

* Load rating listed is for SBN nut, except for 1.000-0.200, 2.000-0.200, 2.000-0.400 and 2.000-0.400 which list the SSN Load rating. Refer to the screw page for specific nut style load ratings.

CONVENIENCE AND MODULARITY

PowerTrac™ modular assemblies are pre-engineered and feature an SRT ball screw, steel mounting flange with an SBN ball nut, one single and one double bearing EZZE-MOUNT™ support. One end of the mounted screw is provided with a drive shaft and keyway for coupling the assembly to a drive mechanism.



Use the reference number below to select the assembly that meets the design requirement. See page 214-218 for EZZE-MOUNT™ information and page 212-213 for End Machining information.

EXAMPLE:

0631-0200 SRT RH / EK / CN / 24.5 / SBN10325 / FS

Is a 0631-0200 SRT right hand alloy steel rolled Screw with an SBN10325 ball nut Universal Double and a Universal Single EZZE-MOUNT™ overall Length of 24.50".

Note: Ball nut direction must be specified at the time of order.

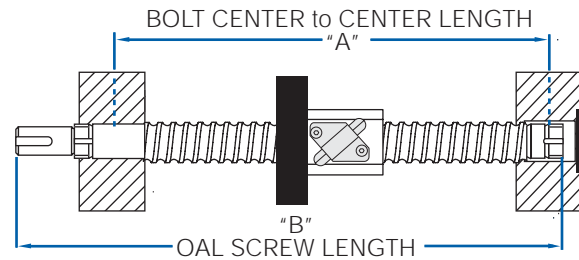

NOTE: "A" & "B" Dimensions reflect a 1/2" over travel at each end.

SCREW DIA.	LEAD	BOLT CENTER "A"	O.A.L. "B"	REFERENCE NUMBER	Page
0375-0125	0.125	3.00" + Travel	4.78" + Travel	0375-0125 SRT RH / EK / CN / "B" / SBN9574 / FS	99
0500-0200	0.200	4.71" + Travel	7.16" + Travel	0500-0200 SRT RH / EK / CN / "B" / SBN10094 / FS	100
0500-0500	0.500	4.03" + Travel	5.90" + Travel	0500-0500 SRT RH / EK / CN / "B" / SBN9582 / FS	101
0631-0200	0.200	4.09" + Travel	7.14" + Travel	0631-0200 SRT RH / EK / CN / "B" / SBN10325 / FS	102
0631-0500	0.500	4.09" + Travel	7.14" + Travel	0631-0500 SRT RH / EK / CN / "B" / SBN10113 / FS	106
0750-0200	0.200	4.25" + Travel	7.23" + Travel	0750-0200 SRT RH / EK / CN / "B" / SBN7201 / FS	107
0750-0500	0.500	5.31" + Travel	8.28" + Travel	0750-0500 SRT RH / EK / CN / "B" / SBN7500 / FS	109
0875-0200	0.200	5.38" + Travel	8.65" + Travel	0875-0200 SRT RH / EK / CN / "B" / SBN8277 / FS	110
1000-0250	0.250	5.08" + Travel	9.00" + Travel	1000-0250 SRT RH / EK / CN / "B" / SBN7508 / FS	113
1000-0500	0.500	5.85" + Travel	9.77" + Travel	1000-0500 SRT RH / EK / CN / "B" / SBN1050 / FS	116
1000-1000	1.000	5.72" + Travel	9.64" + Travel	1000-1000 SRT RH / EK / CN / "B" / SBN7509 / FS	117
1150-0200	0.200	5.44" + Travel	9.59" + Travel	1150-0200 SRT RH / EK / CN / "B" / SBN1566 / FS	118
1250-0200	0.200	6.23" + Travel	10.38" + Travel	1250-0200 SRT RH / EK / CN / "B" / SBN10187 / FS	121
1250-0500	0.500	6.52" + Travel	10.67" + Travel	1250-0500 SRT RH / EK / CN / "B" / SBN10104 / FS	123
1500-0250	0.250	5.81" + Travel	10.41" + Travel	1500-0250 SRT RH / EK / CN / "B" / SBN9587 / FS	126
1500-0473	0.413	7.25" + Travel	11.40" + Travel	1500-0473 SRT RH / EK / CN / "B" / SBN7513 / FS	128
1500-0500	0.500	8.53" + Travel	12.68" + Travel	1500-0500 SRT RH / EK / CN / "B" / SBN1550 / FS	129
1500-1000	1.000	6.57" + Travel	10.72" + Travel	1500-1000 SRT RH / EK / CN / "B" / SBN8280 / FS	131
1500-1875	1.875	7.94" + Travel	12.54" + Travel	1500-1875 SRT RH / EK / CN / "B" / SBN7654 / FS	132



CONVENIENCE AND MODULARITY

PowerTrac™ modular assemblies are pre-engineered and feature an SRT ball screw, steel mounting flange with an SBN ball nut, one single and one double bearing EZZE-MOUNT™ support with motor mount. One end of the mounted screw is provided with a drive shaft and keyway for coupling the motor mount assembly.



Use the reference number below to select the assembly that meets the design requirement. See page 214-218 for EZZE-MOUNT™ information and page 212-213 for End Machining information.

EXAMPLE:

0631-0200 SRT RH / U2 / CN / 24.5 / SBN10325/ FS

Is a 0631-0200 SRT right hand alloy steel rolled Screw with an SBN0827 ball nut EZM-3012-23 Universal Double Bearing Support with Motor Mount and a Universal Single EZZE-MOUNT™ overall Length of 24.50".

Note: Ball nut direction must be specified at the time of order.

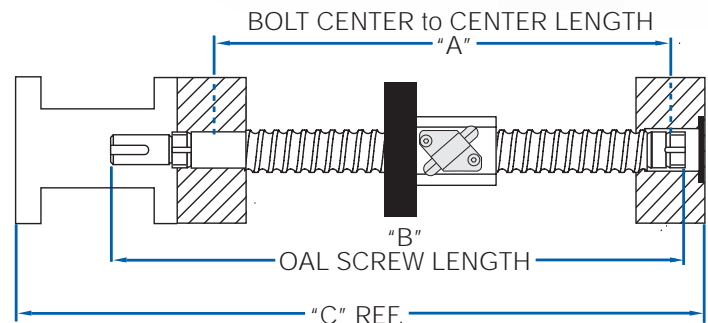

NOTE: "A" & "B" Dimensions reflect a 1/2" over travel at each end.

PRECISION BALL SCREW ASSEMBLY TECHNICAL INTRODUCTION

SCREW DIA.	LEAD	ADD MEASUREMENT BELOW + TRAVEL			REFERENCE NUMBER	MOTOR MOUNT	PAGE
		BOLT CENTER "A"	O.A.L "B"	"C" REF.			
0500-0200	0.200	4.71"	7.16"	8.88"	0500-0200 SRT RH / U2 / CN / "B" / SBN10094 / FS	EZM-3010-23	100
0500-0500	0.500	4.03"	5.90"	7.44"	0500-0500 SRT RH / U1 / CN / "B" / SBN9582 / FS	EZM-1008-17	101
0631-0200	0.200	4.09"	7.14"	8.57"	0631-0200 SRT RH / U2 / CN / "B" / SBN10325 / FS	EZM-3012-23	102
0631-0500	0.500	4.09"	7.14"	8.57"	0631-0500 SRT RH / U2 / CN / "B" / SBN10113 / FS	EZM-3012-23	106
0750-0200	0.200	4.25"	7.23"	8.95"	0750-0200 SRT RH / U2 / CN / "B" / SBN7201 / FS	EZM-3015-23	107
0750-0500	0.500	5.31"	8.28"	10.00"	0750-0500 SRT RH / U2 / CN / "B" / SBN7500 / FS	EZM-3015-23	109
0875-0200	0.200	5.38"	8.65"	10.64"	0875-0200 SRT RH / U3 / CN / "B" / SBN8277 / FS	EZM-3017-34	110
1000-0250	0.250	5.08"	9.00"	11.04"	1000-0250 SRT RH / U3 / CN / "B" / SBN7508 / FS	EZM-2020-34	113
1000-0500	0.500	5.85"	9.77"	11.81"	1000-0500 SRT RH / U3 / CN / "B" / SBN1050 / FS	EZM-2020-34	116
1000-1000	1.000	5.72"	9.64"	11.68"	1000-1000 SRT RH / U3 / CN / "B" / SBN7509 / FS	EZM-2020-34	117
1150-0200	0.200	5.44"	9.59"	11.88"	1150-0200 SRT RH / U3 / CN / "B" / SBN1566 / FS	EZM-3025-34	118
1250-0200	0.200	6.23"	10.38"	12.67"	1250-0200 SRT RH / U3 / CN / "B" / SBN10187 / FS	EZM-3025-34	121
1250-0500	0.500	6.52"	10.67"	12.96"	1250-0500 SRT RH / U3 / CN / "B" / SBN10104 / FS	EZM-3025-34	123
1500-0250	0.250	5.81"	10.41"	12.79"	1500-0250 SRT RH / U3 / CN / "B" / SBN9587 / FS	EZM-2030-34	126
1500-0473	0.413	7.25"	11.40"	13.70"	1500-0473SRT RH / U3 / CN / "B" / SBN7513 / FS	EZM-3025-34	128
1500-0500	0.500	8.53"	12.68"	14.97"	1500-0500 SRT RH / U3 / CN / "B" / SBN1550 / FS	EZM-3025-34	129
1500-1000	1.000	6.57"	10.72"	13.01"	1500-1000 SRT RH / U3 / CN / "B" / SBN8280 / FS	EZM-3025-34	131
1500-1875	1.875	7.94"	12.54"	14.91"	1500-1875 SRT RH / U3 / CN / "B" / SBN7654 / FS	EZM-2030-34	132

CONVENIENCE AND MODULARITY

These PowerAc™ modular assemblies are pre-engineered and feature a 2-C acme screw, steel mounting flange with choice of nut material, one single and one double bearing EZZE-MOUNT™ support. Drive end of the mounted screw is provided with a HandWheel for manual operation.

Use the reference number below to select the assembly that meets the design requirement. See page 214-218 for EZZE-MOUNT™ information, page 212-213 for End Machining information and page 287 for HandWheel information.

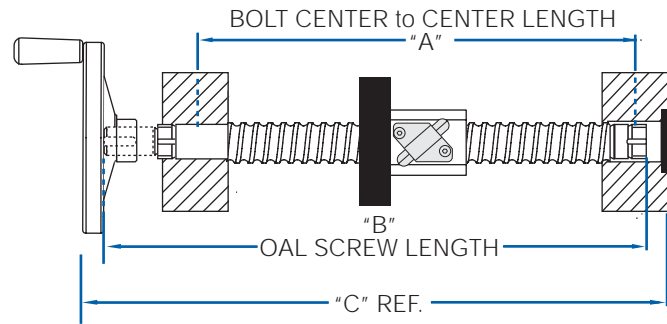

NOTE: "A" & "B" Dimensions reflect a 1/2" over travel at each end.

EXAMPLE:

0631-0200 SRT RH / EQ / CN / 24.5 / SBN10325 / FS

Is a 0631-0200 SRT right hand alloy steel rolled screw with an SBN0827 ball nut Universal Double and Universal Single EZZE-MOUNT™ overall length of 24.50", with HandWheel 4" diameter.

Note: Ball nut direction must be specified at the time of order.

SCREW DIA.	LEAD	ADD MEASUREMENT BELOW + TRAVEL			REFERENCE NUMBER	HANDWHEEL		PAGE
		BOLT CENTER "A"	O.A.L "B"	"C" REF.		SIZE	PART NO.	
0631-0200	0.200	4.09"	7.14"	7.88"	0631-0200 SRT RH / EQ / CN / "B" / SBN10325 / FS	4"	HO43*	102
0631-0500	0.500	4.09"	7.14"	7.88"	0631-0500 SRT RH / EQ / CN / "B" / SBN10113 / FS	4"	HO43*	106
0750-0200	0.200	4.25"	7.23"	7.94"	0750-0200 SRT RH / EQ / CN / "B" / SBN7201 / FS	4"	HO44	107
0750-0500	0.500	5.31"	8.28"	8.99"	0750-0500 SRT RH / EQ / CN / "B" / SBN7500 / FS	4"	HO44	109
0875-0200	0.200	5.38"	8.65"	9.48"	0875-0200 SRT RH / EQ / CN / "B" / SBN8277 / FS	6"	HO64	110
1000-0250	0.250	5.08"	9.00"	9.86"	1000-0250 SRT RH / EQ / CN / "B" / SBN7508 / FS	6"	HO65**	113
1000-0500	0.500	5.85"	9.77"	10.63"	1000-0500 SRT RH / EQ / CN / "B" / SBN1050 / FS	6"	HO65**	116
1000-1000	1.000	5.72"	9.64"	10.50"	1000-1000 SRT RH / EQ / CN / "B" / SBN7509 / FS	6"	HO65**	117
1150-0200	0.200	5.44"	9.59"	10.64"	1150-0200 SRT RH / EQ / CN / "B" / SBN1566 / FS	8"	HO86	118
1250-0200	0.200	6.23"	10.38"	11.43"	1250-0200 SRT RH / EQ / CN / "B" / SBN10187 / FS	8"	HO86	121
1250-0500	0.500	6.52"	10.67"	11.72"	1250-0500 SRT RH / EQ / CN / "B" / SBN10104 / FS	8"	HO86	123
1500-0250	0.250	5.81"	10.41"	11.43"	1500-0250 SRT RH / EQ / CN / "B" / SBN9587 / FS	8"	HO88	126
1500-0473	0.413	7.25"	11.40"	12.46"	1500-0473SRT RH / EQ / CN / "B" / SBN7513 / FS	8"	HO86	128
1500-0500	0.500	8.53"	12.68"	13.73"	1500-0500 SRT RH / EQ / CN / "B" / SBN1550 / FS	8"	HO86	129
1500-1000	1.000	6.57"	10.72"	11.77"	1500-1000 SRT RH / EQ / CN / "B" / SBN8280 / FS	8"	HO86	131
1500-1875	1.875	7.94"	12.54"	13.55"	1500-1875 SRT RH / EQ / CN / "B" / SBN7654 / FS	8"	HO88	132

*Indicates modified Type III End Machining required.

**HO65 HandWheel has the same outer dimensions as HO64, but different bore.

Other combinations of screw assemblies and handwheels available upon request.



Twin-lead ball screws offer dual opposing motion using a single drive system. These one-piece high performance ball screws are made from high alloy steel that is black oxidized for protection. Twin-lead ball screw assemblies can be assembled with Nook PowerTrac™ ball nuts, flanges and EZZE-MOUNT™ (see page 214-218) bearing supports to form cost effective systems. Twin-lead ball screws can be used in molding machines, packaging equipment, food processing machinery, robotics, material handling equipment, tire manufacturing and assembly applications.



Twin-lead ball screws can be used in molding machines, packaging equipment, food processing machinery, robotics, material handling equipment, tire manufacturing and assembly applications.

- Lead accuracy of ± 0.004 "/foot is standard
- For a shorter unthreaded center section, contact Nook Industries customer service. 800-321-7800

Twin-Lead screws are stocked for quick delivery without machined ends in the sizes in the left chart below. To order a twin-lead cut to a custom length and/or with machined ends, select a size from the Twin-Lead Chart, determine OAL, LH and RH thread length, nut, flange and, if required, EZZE-MOUNT™ bearing support.

Consult the Twin-Lead Reference Number System on the next page to complete your part number.

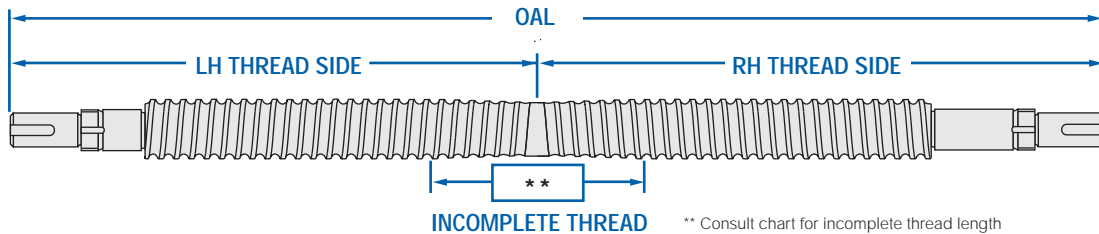

STOCKED SIZES WITHOUT END MACHINING

SCREW SIZE DIA-LEAD	ROOT DIA. (min)	MAX OVERALL LENGTH	MAX USEABLE LH & RH THREAD	INCOMPLETE OVERLAPPING THREAD LENGTH	PAGE
0375-0125	0.300	36	16.50	2.50	99
0631-0200	0.500	72	34.25	3.00	102
1000-0250	0.820	96	46.25	3.00	113
1150-0200	1.015	108	52.50	3.00	118
1250-0200	1.115	108	52.50	3.00	121
1500-0250	1.320	108	52.25	3.50	126
1500-1000	1.140	192	94.00	4.00	131

SIZES AVAILABLE ON ORDER

SCREW SIZE DIA-LEAD	ROOT DIA. (min)	MAX OVERALL LENGTH	MAX USEABLE LH & RH THREAD	INCOMPLETE OVERLAPPING THREAD LENGTH	PAGE
2000-0200†	1.849	140	69.00	2.00	134
2250-0500	1.850	192	93.50	5.00	135
2500-0250	2.320	192	94.00	4.00	138
3000-0660	2.480	192	93.50	5.00	140

Measurements in inches † SGT - Ground Screw Only

1000-0250 SRT TA / EK / 4N / 33.50 / 16.75 / 16.75 / SBN7535A / SBN7508A / FS

TWIN-LEAD BALL SCREW

Thread Form Codes

Part#	Dia. - Lead	Part#	Dia. - Lead
0375-0125	= 0.375-0.125	1500-1000	= 1.500-1.000
0631-0200	= 0.631-0.200	2000-0200	= 2.000-0.200
1000-0250	= 1.000-0.250	2250-0500	= 2.250-0.500
1150-0200	= 1.150-0.200	2500-0250	= 2.500-0.250
1250-0200	= 1.250-0.200	3000-0660	= 3.000-0.660
1500-0250	= 1.500-0.250		

PRECISION

SRT = Standard Rolled Thread ±0.004"/ft.
SGT = Precision Ground Thread ±0.0005"/ft.

NOTE: Not all precisions are available for all sizes.

MATERIAL

TA = Twin-Lead Alloy
TS = Twin-Lead Stainless Steel

NOTE: Not all materials are available for all sizes.

FIRST END CONFIGURATION

EZZE-MOUNT™ / End Machining **EK**

(see page 214 & 212)

- 1 = Type 1 3 = Type 3
- 2 = Type 2 4 = Type 4

- B** = Universal Double Bearing Support End Cap Facing Screw Thread
- C** = Universal Single Bearing Support
- D** = Flanged Single Bearing Support Flange Facing Screw Thread
- E** = Universal Double Bearing Support End Cap Facing Away From Screw Thread
- F** = Flanged Double Bearing Support Flange Facing Screw Thread
- G** = Flanged Single Bearing Support Flange Facing Away From Screw Thread
- H** = Flanged Double Bearing Support Flange Facing Away From Screw Thread
- U_** = Universal Double Bearing Support with Motor Mount (see page 217)
- Y_** = Flanged Double Bearing Support with Motor Mount (see page 218)

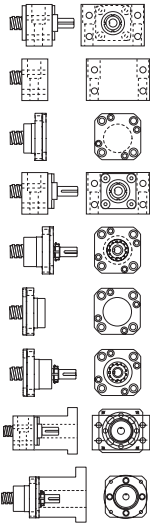

EK = Universal Double Bearing Support, with Keyway

Shaft Extension
(see page 188)

- K** = Shaft Extension with Keyway
- L** = Shaft Extension without Keyway
- Q** = HandWheel
- N** = No Shaft Extension

NOTE: Both Ends must be specified.

Single Bearing Supports are used in conjunction with Type 1N end machining.

Double Bearing Supports are used in conjunction with Type 3K, 3L, or 3N end machining.

SECOND END CONFIGURATION

Refer to the First End Configuration section above.

NOTE: Both Ends must be specified.

OVER - ALL - LENGTH (OAL)

Length in inches, 2 place decimal

LEFT HAND THREAD

Length in inches, 2 place decimal **NOTE:** See figure on page 148

RIGHT HAND THREAD

Length in inches, 2 place decimal **NOTE:** See figure on page 148

LEFT HAND BALL NUT

000000 = No Nut

RIGHT HAND BALL NUT

000000 = No Nut

NOTE: To Select the Nut Direction After Nut Part # Add
A = Nut Thread or Flange installed towards center of screw
B = Nut Thread or Flange installed towards end of screw

MODIFIER LIST

F Optional

F = Round Flange

S or M Required

S = Standard, no additional description required M = Modified, additional description required



With over thirty years of experience manufacturing precision ball screws, Nook Industries has expanded the PowerTrac™ offering to include metric ball screws providing design engineers a globally accepted product. Metric ball screws are available in many diameters, leads, and pitches.

The metric ball screws are available with internal, low profile external or external return guide ball nuts in more than 25 sizes. Several Nook metric products are available with preloaded ball nut systems. See the metric ball screw product technical data pages 155-173 for additional detail.

METRIC BALL SCREW AND NUT TECHNICAL DATA



MRT and PMT BALL SCREWS

These screw assemblies are similar in construction and materials to PowerTrac™ Inch Ball Screws and Nuts.

MRT Standard lead accuracy:

±100µm / 300mm

PMT Standard lead accuracy:

±25µm / 300mm

Temperature Range:

For standard applications: -20° to +80° C

Wipers: Plastic

CARRY™ BALL SCREWS

PowerTrac™ Carry™ Metric Rolled Ball Screws are hardworking and durable. Designed for applications which require predictable life while moving a load with high efficiency and duty cycle. These screws are economical and maintain lead accuracy that is appropriate for most industrial applications.

Made of hardened alloy PowerTrac™ Carry™ ball screws are matched with a range of durable ball nuts with either external low-profile returns or internal returns. Their compact shape enhances the inherent advantages of ball screw design.

Standard lead accuracy: is ±100µm / 300mm
±50µm / 300mm available on request.

Temperature Range:

For standard applications: -20° to +80° C

Wipers: Plastic or brush

CARRY™ BALL NUTS

TYPE Z:

Internal Return or Low-Profile
External Return



TYPE FG:

Internal Return or Low-Profile
External Return



TYPE FB:

Internal Return or Low-Profile
External Return



16x50:

Internal
Return



TO USE THIS CHART:

1) Determine required Life
(in meters of travel)
at equivalent operating load.

2) Find point at which load and life
requirement intersect.

3) Select ball nut to the right or above
the intersect point.

NOTE: IF USING A BALL SCREW
WITHOUT LUBRICANT
DE-RATE LIFE BY 90%

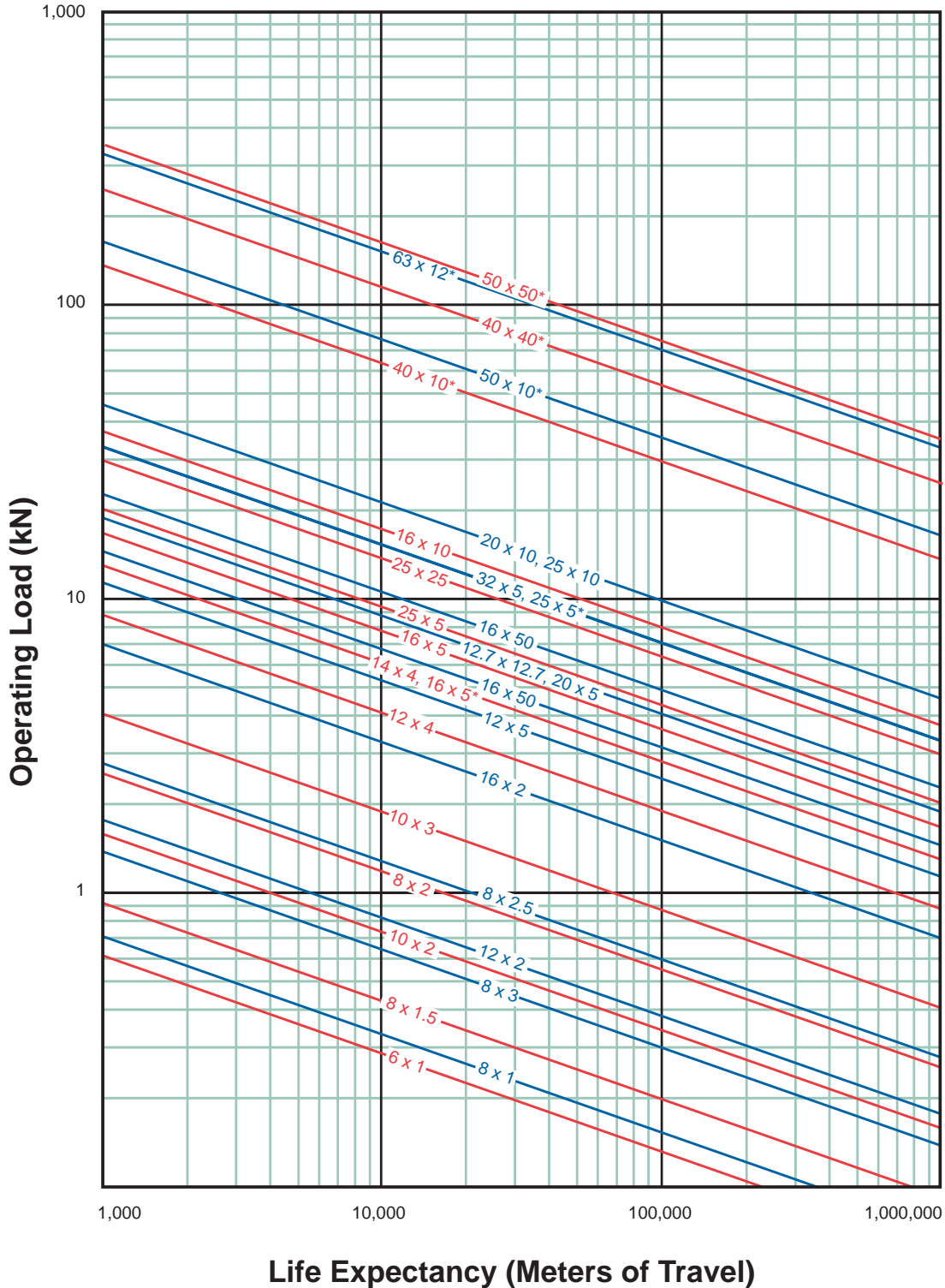

* Indicates ISO
Standard Thread

METRIC BALL SCREW AND NUT TECHNICAL DATA



Use this chart to verify the screw selected has sufficient column strength for your load.

TO USE THIS CHART: find a point at which the maximum length between bearing and load intersects the maximum load. Be sure the screw selected is above and to the right of that point.

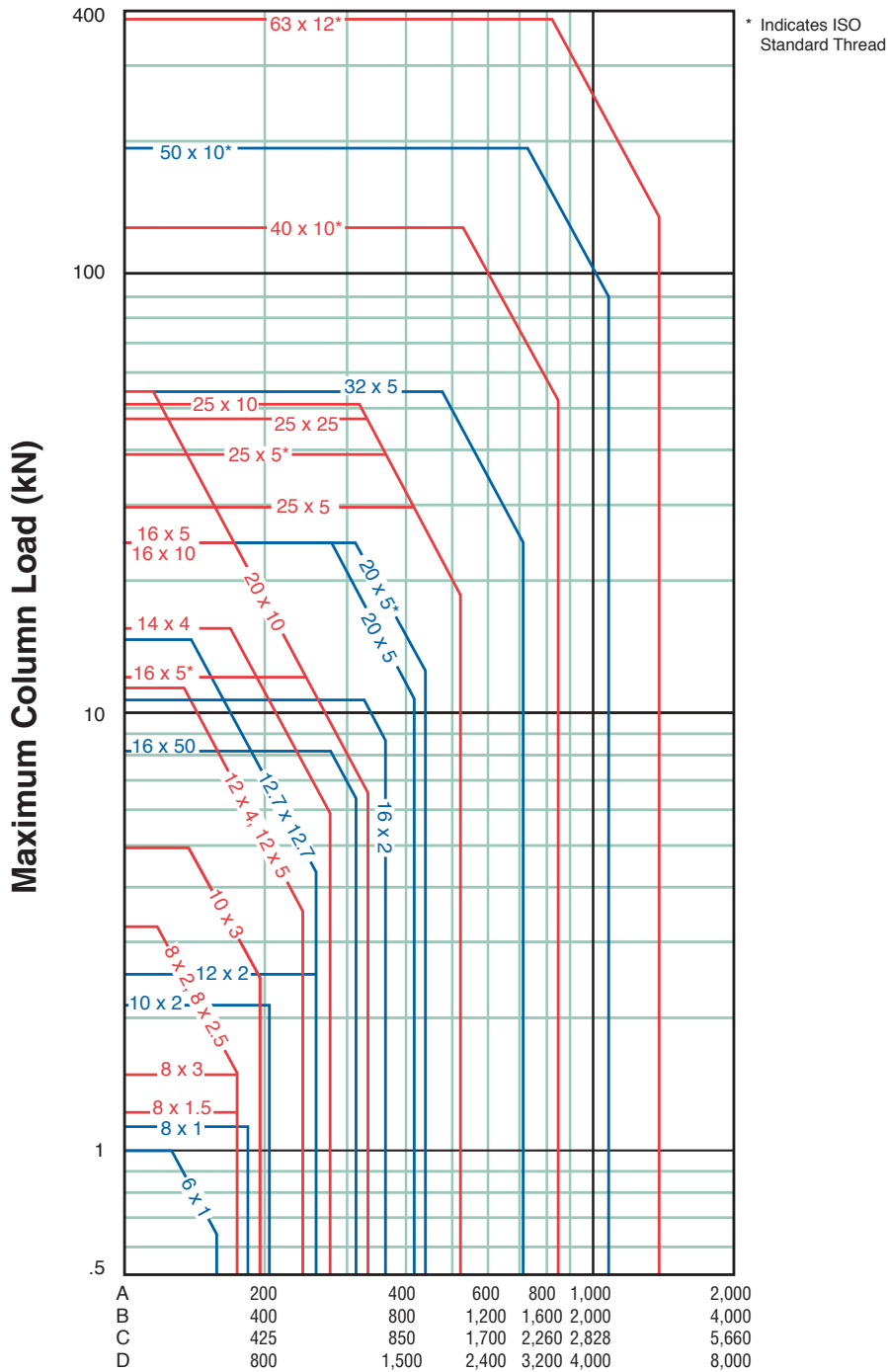

Maximum Length Between Bearings (mm)

See Page 87 for Reference Description on "A-B-C-D" end fixity.

Metric to Inch Conversions:

1 Newton = .224 lbf 1mm = 0.039 in. 1 N•m = 8.85 in.-lb.

METRIC BALL SCREW AND NUT TECHNICAL DATA

TO USE THIS CHART:

- 1) Determine maximum travel rate required.
- 2) Determine screw length "L".
- 3) Find point at which travel rate and screw length intersect.
Select a screw above and to the right of that point.

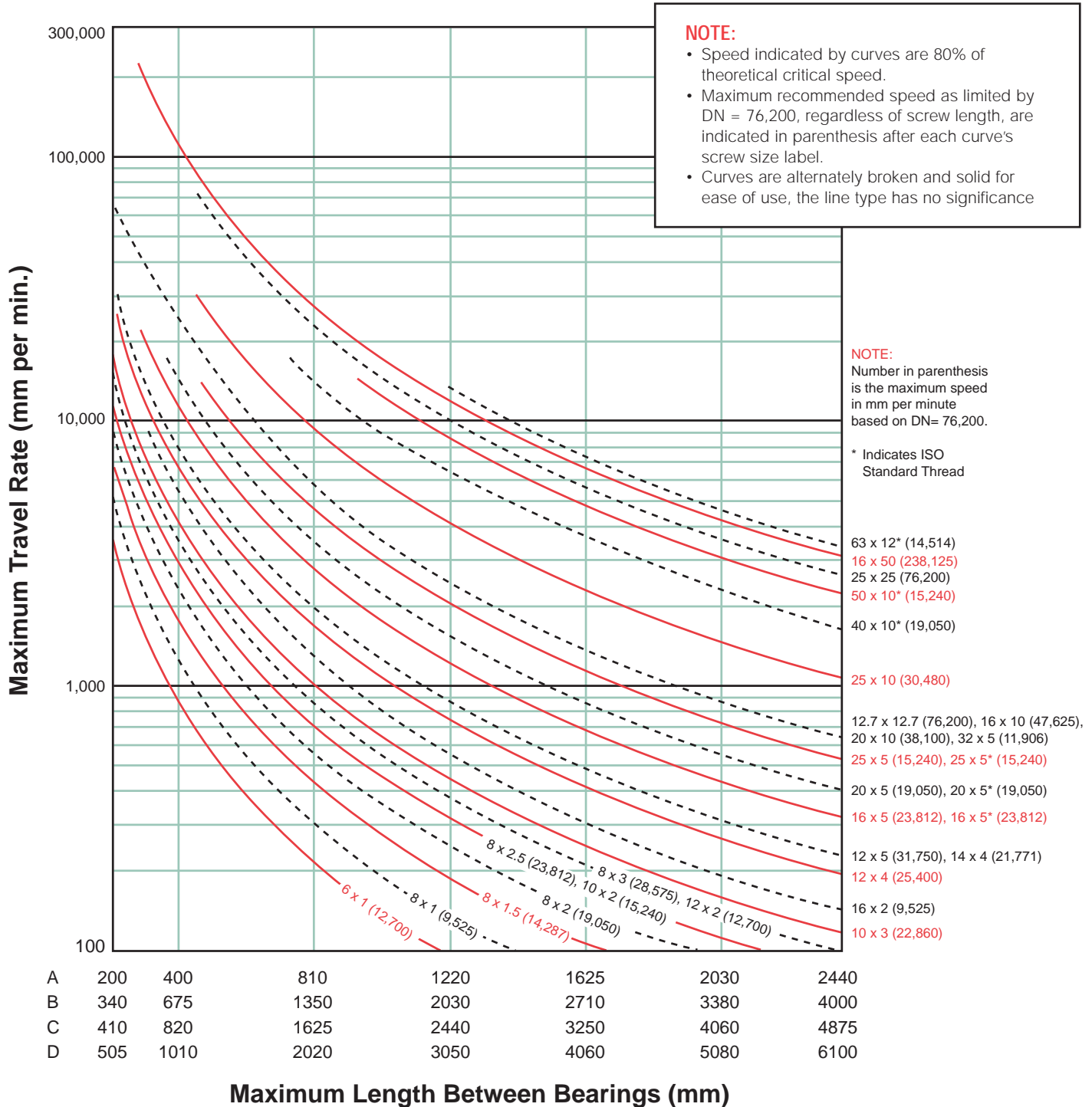

METRIC BALL SCREW AND NUT TECHNICAL DATA

Maximum Length Between Bearings (mm)

See Page 87 for Reference Description on "A-B-C-D" end fixity.

Metric to Inch Conversions:

1 Newton = .224 lbf 1mm = 0.039 in. 1 N·m = 8.85 in.-lb.

ECS-16020 - RA / EK / 4N / 1063 / ECN-16020-RBU / S

METRIC BALL SCREW AND NUT TECHNICAL DATA

BALL SCREW

Carry Part#	Dia. x Lead	Thread Form Codes	Carry Part#	Dia. x Lead	Part#	Dia. x Lead
ECS-06010	= 6 x 1	ECS-14040	= 14 x 4	MRT 16x5	= 16 x 5	
ECS-08010	= 8 x 1	ECS-16020	= 16 x 2	MRT 20x5	= 20 x 5	
ECS-08015	= 8 x 1.5	ECS-16050	= 16 x 5	MRT 25x5	= 25 x 5	
ECS-08020	= 8 x 2	ECS-16100	= 16 x 10	MRT 40x10	= 40 x 10	
ECS-08025	= 8 x 2.5	ECS-16500	= 16 x 50	MRT 50x10	= 50 x 10	
ECS-08030	= 8 x 3	ECS-20050	= 20 x 5	MRT 63x12	= 63 x 12	
ECS-10020	= 10 x 2	ECS-20010	= 20 x 10	PMT 16x5	= 16 x 5	
ECS-10030	= 10 x 3	ECS-25050	= 25 x 5	PMT 20x5	= 20 x 5	
ECS-12020	= 12 x 2	ECS-25100	= 25 x 10	PMT 25x5	= 25 x 5	
ECS-12040	= 12 x 4	ECS-25250	= 25 x 25	PMT 40x10	= 40 x 10	
ECS-12050	= 12 x 5	ECS-32050	= 32 x 5	PMT 50x10	= 50 x 10	
ECS-12120	= 12.7 x 12.7			PMT 63x12	= 63 x 12	

MATERIAL

THREAD	RA	MATERIAL
R = Right Hand		A = Alloy Steel - Rolled
L = Left Hand		B = Alloy Steel - Precision Rolled
		S = Stainless Steel - Rolled

NOTE: Not all materials/threads are available for all sizes.

FIRST END CONFIGURATION

EZZE-MOUNT™ / End Machining

(see page 214 & 212)

- 1 = Type 1
- 2 = Type 2
- 3 = Type 3
- 4 = Type 4

- B = Universal Double Bearing Support End Cap Facing Screw Thread
- C = Universal Single Bearing Support
- D = Flanged Single Bearing Support Flange Facing Screw Thread
- E = Universal Double Bearing Support End Cap Facing Away From Screw Thread
- F = Flanged Double Bearing Support Flange Facing Screw Thread
- G = Flanged Single Bearing Support Flange Facing Away From Screw Thread
- H = Flanged Double Bearing Support Flange Facing Away From Screw Thread
- U = Universal Double Bearing Support with Motor Mount (see page 217)
- Y = Flanged Double Bearing Support with Motor Mount (see page 218)

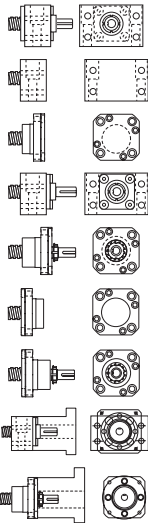

EK EK = Universal Double Bearing Support, with Keyway

Shaft Extension

(see page 212)

- K = Shaft Extension with Keyway
- L = Shaft Extension without Keyway
- N = No Shaft Extension

NOTE: Both Ends must be specified.

Single Bearing Supports are used in conjunction with Type 1N end machining.

Double Bearing Supports are used in conjunction with Type 3K, 3L, or 3N end machining.

SECOND END CONFIGURATION

Refer to the First End Configuration section above.

NOTE: Both Ends must be specified.

OVER - ALL - LENGTH (OAL)

Length in mm.

TRAVEL NUT

CARRY NUT

ECN - 16020 - R B U

Nut Thread Code	N = No Wiper	U = With Wiper
MATERIAL	NUT STYLE	
R = Right Hand Alloy	Z = Type Z Nut	H = 16 x 50 Nut
L = Left Hand Alloy	G = Type FG	
S = Right Hand Stainless Steel		
M = Left Hand Stainless Steel		

- A = Type FB Round Flange
- B = Type FB Standard Flange
- C = Type FB "D" Flange

- K = Type FB Round Flange High Load
- J = Type FB Standard Flange High Load
- L = Type FB "D" Flange High Load

MRT or PMT NUT

Use standard part number found in the Technical Data Section for Metric Ball Screws.
Example:
MBN 10206 = 16 x 5 MRT Nut

Nut will be installed with flange or threaded end toward first end designation. 00000 = No Nut

MODIFIER LIST

F (Optional for MRT and PMT Screws Only)

S or M Required

F = Round Flange

S = Standard, no additional description required

M = Modified, additional description required

6mm Carry™ METRIC THREAD

LEAD ACCURACY: ±100µm/300mm

Carry Type Z Ball Nut

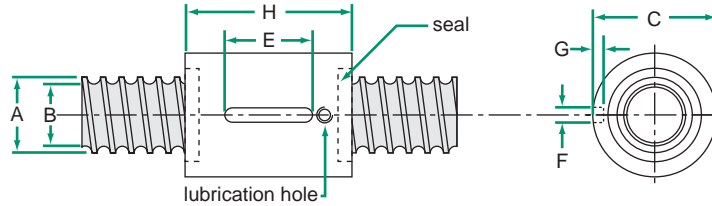

dimensions in mm

SCREW SPECIFICATIONS						NUT SPECIFICATIONS												
dia x lead	helix	reference number*	A	B root dia	wgt. (g/m)	part number	C	H	E	F	G	lash	wiper**	ball return location	wgt. (g)	torque to raise 1 kN (N·m)	load rating (N)	
																	Dyn. (C _d)	Static (C _{0a})
6 x 1	RH	ECS-06010-RA	6.0	5.0	196	ECN-06010-□ZN	12	14	8	2	1.0	0.03	—	Internal	8	0.178	600	1000

*Lengths available up to 3,000 mm. See page 154 and 174 to complete reference number **All nuts with wiper feature an M5 lubrication hole.

END MACHINING

Machining for Nook standard ends or custom requirement available.

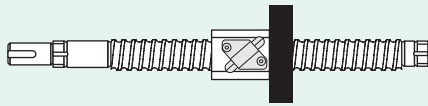

See page 212 for complete product details.

LUBRICANT

Prolong ball screw and nut performance with this special lubricant.



E-900 12oz. Spray or 32oz. Liquid
See page 95 for complete product details.



8mm Carry™ METRIC THREAD

LEAD ACCURACY: ±100µm/300mm

Carry Type Z Ball Nut

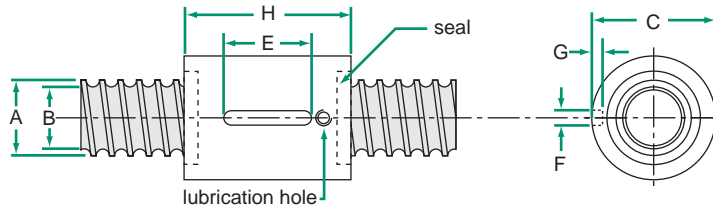

dimensions in mm

SCREW SPECIFICATIONS						NUT SPECIFICATIONS												
dia x lead	helix	reference number*	A	B root dia	wgt. (g/m)	part number	C	H	E	F	G	lash	wiper**	ball return location	wgt. (g)	torque to raise 1 kN (N·m)	load rating (N)	
																	Dyn. (C _a)	Static (C _{0a})
8 x 1	RH	ECS-08010-RA	8.0	7.0	357	ECN-08010-RZN	14	14	8	2	1.2	0.03	—	Internal	9	0.178	700	1200
8 x 1.5	RH	ECS-08015-R□	8.0	6.7	322	ECN-08015-□ZLN	14	14	8	2	1.2	0.04	—	Internal	17	0.254	800	1300
8 x 2	RH	ECS-08020-RA	8.0	6.5	295	ECN-08020-RZN	16	14	8	2	1.2	0.06	—	External	18	0.356	2000	3200
8 x 2.5	RH	ECS-08025-R□	8.0	6.6	335	ECN-08025-RZN	18	16	10	3	2.0	0.06	—	External	22	0.432	2000	3200
8 x 3	RH	ECS-08030-RA	8.0	6.7	352	ECN-08030-RZN	14	12	8	2	1.2	0.05	—	Internal	16	0.533	950	1500

*Lengths available up to 3,000 mm. See page 154 and 174 to complete reference number **All nuts with wiper feature an M5 lubrication hole.

Carry Type FG Ball Nut

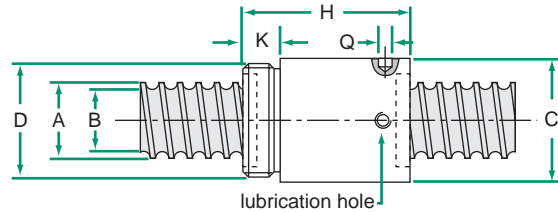

dimensions in mm

SCREW SPECIFICATIONS						NUT SPECIFICATIONS												
dia x lead	helix	reference number*	A	B root dia	wgt. (g/m)	part number	C	D	H	K	Q	lash	wiper**	ball return location	wgt. (g)	torque to raise 1 kN (N·m)	load rating (N)	
																	Dyn. (C _a)	Static (C _{0a})
8 x 1.5	RH	ECS-08015-R□	8.0	6.7	322	ECN-08015-□GN	16	M14x1	22	8	2.5	0.04	—	Internal	25	0.254	800	1300
8 x 2.5	RH	ECS-08025-R□	8.0	6.6	335	ECN-08025-□GN	17.5	M15x1	24	8	2.5	0.06	—	External	35	0.432	2000	3200
8 x 3	RH	ECS-08030-RA	8.0	6.7	352	ECN-08030-RGN	16	M14x1	22	8	2.5	0.05	—	Internal	25	0.533	950	150

*Lengths available up to 3,000 mm. See page 154 and 174 to complete reference number **All nuts with wiper feature an M5 lubrication hole.

† Left hand screw not available in stainless steel

Carry Type FB Ball Nut

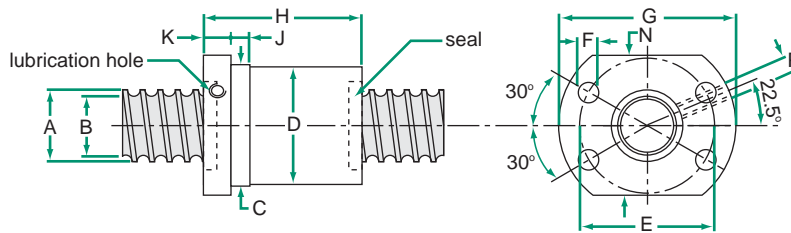

dimensions in mm

SCREW SPECIFICATIONS						NUT SPECIFICATIONS																	
dia x lead	helix	reference number*	A	B root dia	wgt. (g/m)	part number	C	D	E	F	G	H	J	K	N	P	lash	wiper**	ball return location	wgt. (g)	torque to raise 1 kN (N·m)	load rating (N)	
																						Dyn. (C _a)	Static (C _{0a})
8 x 2	RH	ECS-08020-RA	8.1	6.5	295	ECN-08020-RBU	16	15.5	22	3.4	28	25	4	6	19	∅4	0.06	Plastic	External	33	0.356	2000	3200

*Lengths available up to 3,000 mm. See page 154 and 174 to complete reference number **All nuts with wiper feature an M5 lubrication hole.

METRIC BALL SCREW AND NUT TECHNICAL DATA

10mm Carry™ METRIC THREAD

LEAD ACCURACY: ±100µm/300mm

Carry Type Z Ball Nut

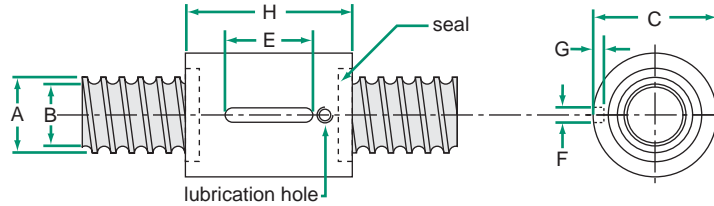

dimensions in mm

SCREW SPECIFICATIONS						NUT SPECIFICATIONS												
dia x lead	helix	reference number*	A	B root dia	wgt. (g/m)	part number	C	H	E	F	G	lash	wiper**	ball return location	wgt. (g)	torque to raise 1 kN (N·m)	load rating (N)	
																	Dyn. (C _a)	Static (C _{oa})
10 x 2	RH	ECS-10020-RA	9.7	8.2	494	ECN-10020-RZN	18	14	10	3	1.2	0.06	—	Internal	15	0.356	1250	2100
10 x 3	RH,LH†	ECS-10030-□□	9.9	7.8	494	ECN-10030-□ZU	22	24	10	3	2.0	0.06	Plastic	External	46	0.541	2800	5000

*Lengths available up to 3,000 mm. See page 154 and 174 to complete reference number **All nuts with wiper feature an M5 lubrication hole.

† Left hand screw not available in stainless steel

Carry Type FG Ball Nut

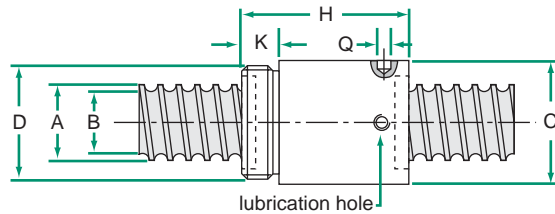

dimensions in mm

SCREW SPECIFICATIONS						NUT SPECIFICATIONS												
dia x lead	helix	reference number*	A	B root dia	wgt. (g/m)	part number	C	D	H	K	Q	lash	wiper**	ball return location	wgt. (g)	torque to raise 1 kN (N·m)	load rating (N)	
																	Dyn. (C _a)	Static (C _{oa})
10 x 2	RH	ECS-10020-RA	9.7	8.2	494	ECN-10020-RGN	18	M16x1	22	8	2.5	0.06	—	Internal	23	0.356	1250	2100
10 x 2	RH	ECS-10020-RA	9.7	8.2	494	ECN-10020-RDN	19.5	M17x1	22	7	2.5	0.06	—	Internal	23	0.356	1700	2800
10 x 3	RH,LH†	ECS-10030-□□	9.9	7.8	494	ECN-10030-□GU	21	M18x1	29	9	3	0.06	Plastic	External	44	0.533	2800	5000

*Lengths available up to 3,000 mm. See page 154 and 174 to complete reference number **All nuts with wiper feature an M5 lubrication hole.

† Left hand screw not available in stainless steel

BALL SCREW ASSEMBLIES

These assemblies are shipped with screw, nut, flange, and bearing supports.

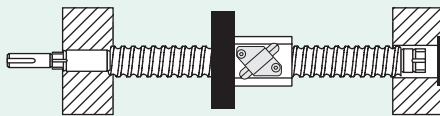

See page 145 for complete product details.

EZZE-MOUNT™ END BEARING SUPPORTS

A convenient solution for mounting ball screw assemblies.

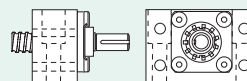

Single or Double Bearing
Universal Mount

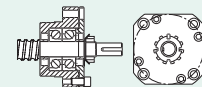

Single or Double Bearing
Flange Mount

See page 214 for complete product details.

METRIC BALL SCREW AND NUT TECHNICAL DATA

12mm Carry™ METRIC THREAD

LEAD ACCURACY: ±100µm/300mm

Carry Type Z Ball Nut

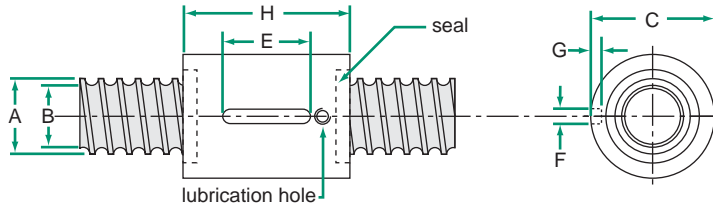

dimensions in mm

SCREW SPECIFICATIONS						NUT SPECIFICATIONS												
dia x lead	helix	reference number*	A	B root dia	wgt. (g/m)	part number	C	H	E	F	G	lash	wiper**	ball return location	wgt. (g)	torque to raise 1 kN (N·m)	load rating (N)	
																	Dyn. (C _a)	Static (C _{0a})
12 x 2	RH	ECS-12020-RA	12.0	10.6	750	ECN-12020-RZN	20	15	10	3	1.2	0.06	—	Internal	19	0.356	1380	2500
12 x 4	RH	ECS-12040-R□	12.0	9.8	739	ECN-12040-□ZN	26	24	10	3	1.8	0.07	—	External	68	0.711	5500	11000
12 x 4	RH	ECS-12040-R□	12.0	9.8	739	ECN-12040-□ZU	26	32	10	3	1.8	0.07	Plastic	External	70	0.711	5500	11000

*Lengths available up to 3,000 mm. See page 154 and 174 to complete reference number **All nuts with wiper feature an M5 lubrication hole.

Carry Type FG Ball Nut

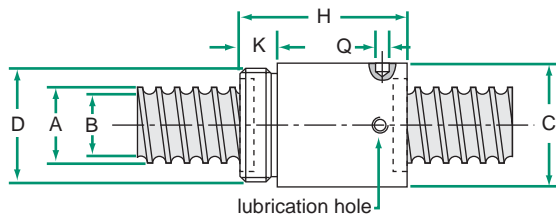

dimensions in mm

SCREW SPECIFICATIONS						NUT SPECIFICATIONS												
dia x lead	helix	reference number*	A	B root dia	wgt. (g/m)	part number	C	D	H	K	Q	lash	wiper**	ball return location	wgt. (g)	torque to raise 1 kN (N·m)	load rating (N)	
																	Dyn. (C _a)	Static (C _{0a})
12 x 2	RH	ECS-12020-RA	12.0	10.6	750	ECN-12020-RGN	20	M18x1	23	8	2.5	0.06	—	Internal	24	0.356	1380	2500
12 x 4	RH	ECS-12040-R□	12.0	9.8	739	ECN-12040-□GN	26	M20x1	32	8	2.5	0.07	—	External	83	0.711	5500	11000
12 x 4	RH	ECS-12040-R□	12.0	9.8	739	ECN-12040-□GU	26	M20x1	34	10	2.5	0.07	Plastic	External	84	0.711	5500	11000
12 x 5	RH	ECS-12050-R□	12.0	9.5	737	ECN-12050-□G□	26	M20x1	37	8	2.5	0.07	Plastic	External	87	0.889	6600	12000
12.7 x 12.7	RH	ECS-12120-R□	13.1	10.3	880	ECN-12120-□G□	29.5	M25x1.5	50	12	3	0.07	Brush	External	134	2.235	8000	15500

*Lengths available up to 3,000 mm. See page 154 and 174 to complete reference number **All nuts with wiper feature an M5 lubrication hole.

Carry Type FB Ball Nut

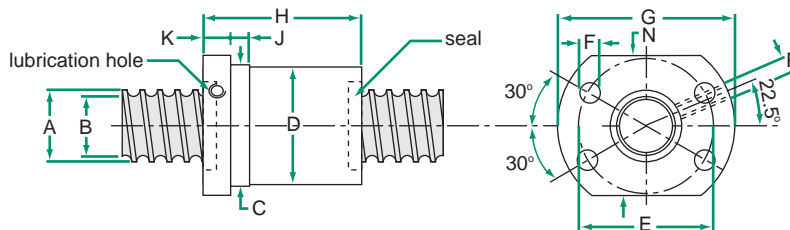

dimensions in mm

SCREW SPECIFICATIONS						NUT SPECIFICATIONS																	
dia x lead	helix	reference number*	A	B root dia	wgt. (g/m)	part number	C	D	E	F	G	H	J	K	N	P	lash	wiper**	ball return location	wgt. (g)	torque to raise 1 kN (N·m)	load rating (N)	
																	Dyn. (C _a)	Static (C _{0a})					
12 x 4	RH	ECS-12040-R□	12.0	9.8	739	ECN-12040-□BU	26	25.5	32	4.5	39.5	36	5	8	28	M5	0.07	Plastic	External	126	0.711	5500	11000
12 x 5	RH	ECS-12050-R□	12.0	9.5	737	ECN-12050-□BU	26	25.5	32	4.5	39.5	40	5	7	28	M5	0.07	Plastic	External	126	0.889	6600	12000

*Lengths available up to 3,000 mm. See page 154 and 174 to complete reference number **All nuts with wiper feature an M5 lubrication hole.

METRIC BALL SCREW AND NUT TECHNICAL DATA

14mm Carry™ METRIC THREAD

LEAD ACCURACY: ±100µm/300mm

Carry Type Z Ball Nut

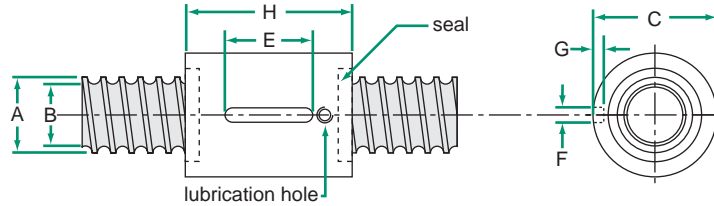

dimensions in mm

SCREW SPECIFICATIONS						NUT SPECIFICATIONS												
dia x lead	helix	reference number*	A	B root dia	wgt. (g/m)	part number	C	H	E	F	G	lash	wiper**	ball return location	wgt. (g)	torque to raise 1 kN (N·m)	load rating (N)	
																	Dyn. (C _a)	Static (C _{0a})
14 x 4	RH,LH	ECS-14040-□A	14.0	11.5	986	ECN-14040-□ZN	29	24	16	4	2.5	0.07	—	External	79	0.711	8100	16000
14 x 4	RH,LH	ECS-14040-□A	14.0	11.5	986	ECN-14040-□ZU	29	32	16	4	2.5	0.07	Plastic	External	82	0.711	8100	16000

*Lengths available up to 3,000 mm. See page 154 and 174 to complete reference number **All nuts with wiper feature an M5 lubrication hole.

Carry Type FG Ball Nut

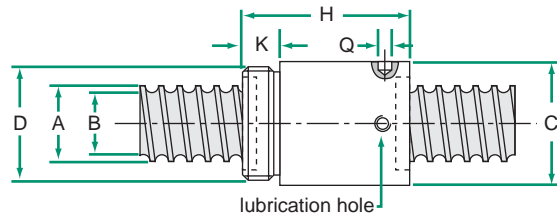

dimensions in mm

SCREW SPECIFICATIONS						NUT SPECIFICATIONS												
dia x lead	helix	reference number*	A	B root dia	wgt. (g/m)	part number	C	D	H	K	Q	lash	wiper**	ball return location	wgt. (g)	torque to raise 1 kN (N·m)	load rating (N)	
																	Dyn. (C _a)	Static (C _{0a})
14 x 4	RH,LH	ECS-14040-□A	14.0	11.5	986	ECN-14040-□GN	29	M22x1.5	32	8	3	0.07	—	External	97	0.711	8100	16000
14 x 4	RH,LH	ECS-14040-□A	14.0	11.5	986	ECN-14040-□GU	29	M22x1.5	38	8	3	0.07	Plastic	External	111	0.711	8100	16000

*Lengths available up to 3,000 mm. See page 154 and 174 to complete reference number **All nuts with wiper feature an M5 lubrication hole.

Carry Type FB Ball Nut

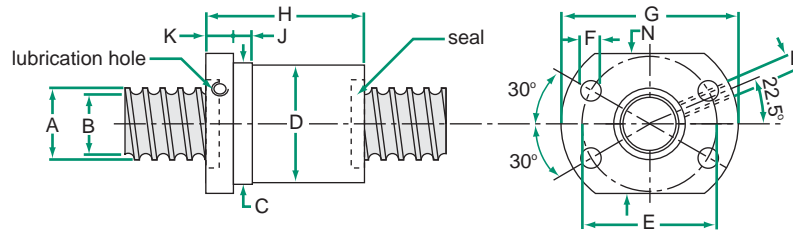

dimensions in mm

SCREW SPECIFICATIONS						NUT SPECIFICATIONS																	
dia x lead	helix	reference number*	A	B root dia	wgt. (g/m)	part number	C	D	E	F	G	H	J	K	N	P	lash	wiper**	ball return location	wgt. (g)	torque to raise 1 kN (N·m)	load rating (N)	
																						Dyn. (C _a)	Static (C _{0a})
14 x 4	RH,LH	ECS-14040-□A	14.0	11.5	986	ECN-14040-□BU	29	28.8	38	5.5	48	40	6	8	36	M5	0.07	Plastic	External	175	0.711	8100	16000

*Lengths available up to 3,000 mm. See page 154 and 174 to complete reference number **All nuts with wiper feature an M5 lubrication hole.

METRIC BALL SCREW AND NUT TECHNICAL DATA

16x5 MRT

LEAD ACCURACY: ±100µm/300mm

Single Start

- 16.0** Ball Circle Diameter
- 5.0** Lead
- 12.9** Root Diameter
- 3.175** Nominal Ball Diameter
- 1222** Screw Mass (g/m)

Available Screw Length	PART NUMBERS
	RH
up to 7 M	16x5MRT
Custom cut lengths available up to 7M. For longer lengths contact customer service.	

MBN Single Circuit Ball Nut

PRODUCT SPECIFICATIONS	RH
Dynamic Load C_a (kN)	7.6
Static Load C_{0a} (kN)	12.4
Torque to Raise 1 kN (N·m)	.88
Nut Weight (g)	123
Ball Nut Number	MBN10436
Flange Part Number	FLG7165
Wiper Kit Part Number	—

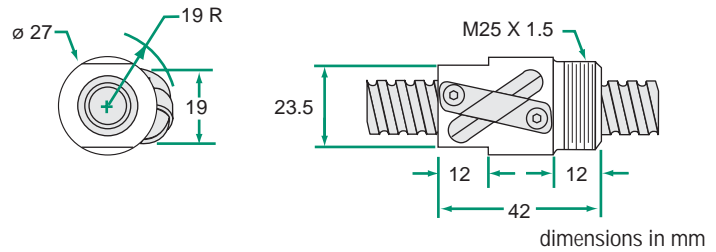

Flange - FLG7165

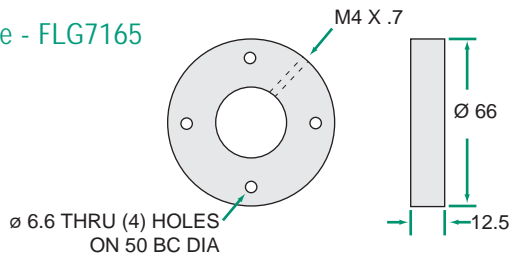

METRIC BALL SCREW AND NUT TECHNICAL DATA

16x5 PMT

LEAD ACCURACY: ±25µm/300mm

Single Start

- 16.0** Ball Circle Diameter
- 5.0** Lead
- 12.9** Root Diameter
- 3.175** Nominal Ball Diameter
- 1222** Screw Mass (g/m)

Available Screw Length	PART NUMBERS
	RH
up to 7 M	16x5PMT
Custom cut lengths available up to 7M. For longer lengths contact customer service.	

MPN Preloaded Flanged Internal Return Ball Nut

PRODUCT SPECIFICATIONS	RH
Dynamic Load C_a (kN)	5.7
Static Load C_{0a} (kN)	8.6
Torque to Raise 1 kN (N·m)	.88
Nut Weight (g)	190
Spring Rate (kN/µm)	.22
Ball Nut Number	MPN10331
Flange	INTEGRAL
Wiper Type	ELASTOMER

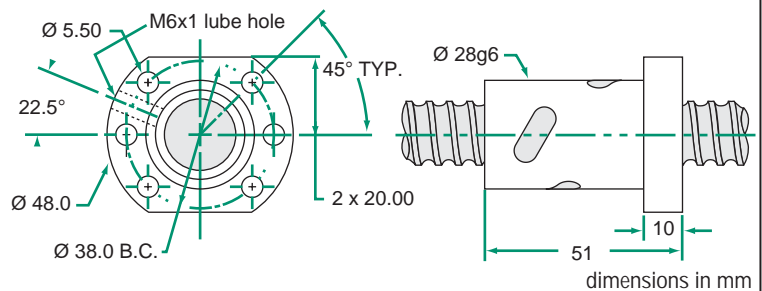

16mm Carry™ METRIC THREAD

LEAD ACCURACY: ±100µm/300mm

Carry Type 16 x 50 Ball Nut

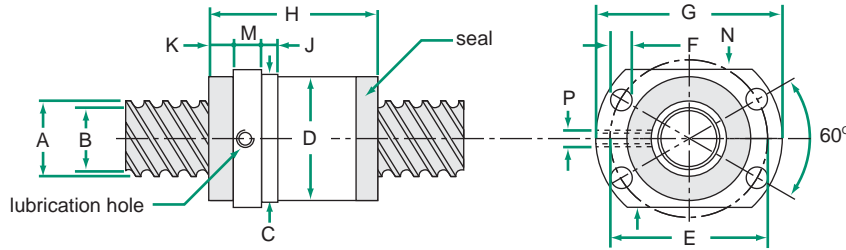

dimensions in mm

SCREW SPECIFICATIONS						NUT SPECIFICATIONS																	
dia x lead	helix	reference number*	A	B root dia	wgt. (g/m)	part number	C	D	E	F	G	H	J	K	M	N	P	wiper**	ball return location	wgt. (g)	torque to raise 1 kN (N·m)	load rating (N)	
																						Dyn. (C _d)	Static (C _{0a})
16 x 50	RH	ECS-16500-RA	15.8	10.6	1250	ECN-16500-RHU	34	33.5	45	5.4	54	46	5	10	10	36	M6	Plastic	Internal	236	8.839	4500	10000

*Lengths available up to 3,000 mm. See page 154 and 174 to complete reference number **All nuts with wiper feature an M5 lubrication hole.

BALL SCREW ASSEMBLIES

These assemblies are shipped with screw, nut, flange, and bearing supports.

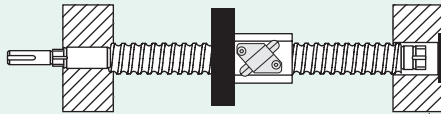

See page 145 for complete product details.

EZZE-MOUNT™ END BEARING SUPPORTS

A convenient solution for mounting ball screw assemblies.

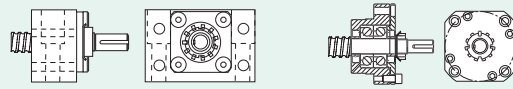

Single or Double Bearing Universal Mount

Single or Double Bearing Flange Mount

See page 214 for complete product details.

END MACHINING

Machining for Nook standard ends or custom requirement available.

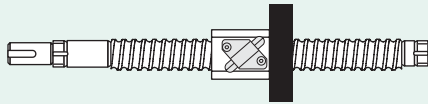

See page 212 for complete product details.

LUBRICANT

Prolong ball screw and nut performance with this special lubricant.



E-900 12oz. Spray or 32oz. Liquid
See page 95 for complete product details.

METRIC BALL SCREW AND NUT TECHNICAL DATA

16mm Carry™ METRIC THREAD

LEAD ACCURACY: ±100µm/300mm

Carry Type Z Ball Nut

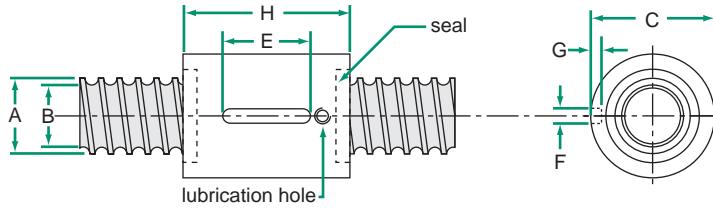

dimensions in mm

SCREW SPECIFICATIONS						NUT SPECIFICATIONS												
dia x lead	helix	reference number*	A	B root dia	wgt. (g/m)	part number	C	H	E	F	G	lash	wiper**	ball return location	wgt. (g)	torque to raise 1 kN (N·m)	load rating (N)	
																	Dyn. (C _a)	Static (C _{0a})
16 x 5	RH	ECS-16050-R□	15.7	13.0	1251	ECN-16050-□ZU	30	43	16	4	2.5	0.07	Plastic	Internal	113	0.889	9700	22000

*Lengths available up to 3,000 mm. See page 154 and 174 to complete reference number **All nuts with wiper feature an M5 lubrication hole.

Carry Type FG Ball Nut

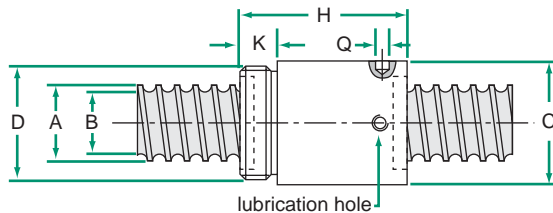

dimensions in mm

SCREW SPECIFICATIONS						NUT SPECIFICATIONS												
dia x lead	helix	reference number*	A	B root dia	wgt. (g/m)	part number	C	D	H	K	Q	lash	wiper**	ball return location	wgt. (g)	torque to raise 1 kN (N·m)	load rating (N)	
																	Dyn. (C _a)	Static (C _{0a})
16 x 2	RH	ECS-16020-RA	16.0	14.5	1416	ECN-16020-RGU	30	M26x1.5	28	12	3.5	0.06	Plastic	External	76	0.356	2500	5500
16 x 5	RH	ECS-16050-R□	15.7	13.0	1251	ECN-16050-□GU	30.2	M26x1.5	50	12	3.5	0.07	Plastic	Internal	123	0.889	9700	22000
16 x 5	RH	ECS-16050-R□	15.7	13.0	1251	ECN-16050-□DN	32	M26x1.5	42	12	4	0.07	—	External	144	0.889	12000	25000
16 x 5	RH	ECS-16050-R□	15.7	13.0	1251	ECN-16020-□DU	32	M26x1.5	47	12	4	0.07	Plastic	External	164	0.889	12000	25000
16 x 10	RH	ECS-16100-RA	15.7	13.0	1251	ECN-16100-RGN	32	M26x1.5	47	12	4	0.07	—	External	165	1.778	17000	25000
16 x 10	RH	ECS-16100-RA	15.7	13.0	1251	ECN-16100-RGU	32	M26x1.5	52	12	4	0.07	Plastic	External	184	1.788	17000	25000

*Lengths available up to 3,000 mm. See page 154 and 174 to complete reference number **All nuts with wiper feature an M5 lubrication hole.

BALL SCREW ASSEMBLIES

These assemblies are shipped with screw, nut, flange, and bearing supports.

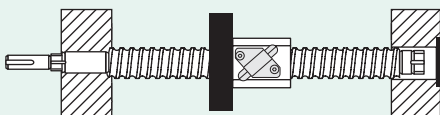

See page 145 for complete product details.

EZZE-MOUNT™ END BEARING SUPPORTS

A convenient solution for mounting ball screw assemblies.

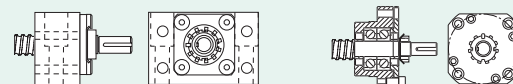

Single or Double Bearing
Universal Mount

Single or Double Bearing
Flange Mount

See page 214 for complete product details.

16mm Carry™ METRIC THREAD

LEAD ACCURACY: ±100µm/300mm

Carry Type FB Ball Nut

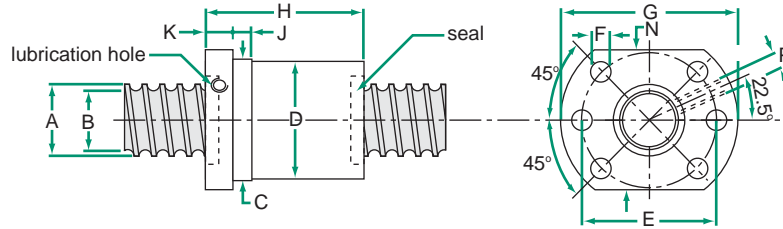

dimensions in mm

SCREW SPECIFICATIONS						NUT SPECIFICATIONS																	
dia x lead	helix	reference number*	A	B root dia	wgt. (g/m)	part number	C	D	E	F	G	H	J	K	N	P	lash	wiper**	ball return location	wgt. (g)	torque to raise 1 kN (N·m)	load rating (N)	
																						Dyn. (C _a)	Static (C _{oa})
16 x 2	RH	ECS-16020-RA	16.0	14.5	1416	ECN-16020-RBU	30	29.5	38	5.5	48	45	6	10	40	M6	0.06	Plastic	External	225	0.356	4500	11000
16 x 5	RH	ECS-16050-R□	15.7	13.0	1251	ECN-16050-□BU	28	27.8	38	5.5	48	45	6	10	40	M6	0.07	Plastic	Internal	160	0.889	9700	22000
16 x 10	RH	ECS-16100-RA	15.7	13.0	1251	ECN-16100-RBU	32	31.5	43	6.6	54	52	6	12	44	M6	0.07	Plastic	External	281	1.778	17000	25000

*Lengths available up to 3,000 mm. See page 154 and 174 to complete reference number **All nuts with wiper feature an M5 lubrication hole.

END MACHINING

Machining for Nook standard ends or custom requirement available.

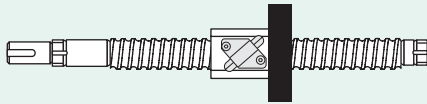

See page 212 for complete product details.



LUBRICANT

Prolong ball screw and nut performance with this special lubricant.

E-900 12oz. Spray or 32oz. Liquid
See page 95 for complete product details.



20x5 MRT

LEAD ACCURACY: ±100µm/300mm

Single Start

- 20.71** Ball Circle Diameter
- 5** Lead
- 17.5** Root Diameter
- 3.175** Nominal Ball Diameter
- 2,170** Screw Mass (g/m)

Available Screw Length	PART NUMBERS
up to 7 M	20x5MRT
Custom cut lengths available up to 7M. For longer lengths contact customer service.	

MBN Internal Return Ball Nut

PRODUCT SPECIFICATIONS	RH
Dynamic Load C_a (kN)	13
Static Load C_{0a} (kN)	24.4
Torque to Raise 1 kN (N·m)	.88
Nut Weight (g)	238
Ball Nut Number	MBN10295
Flange Part Number	FLG10324
Wiper Type	ELASTOMER

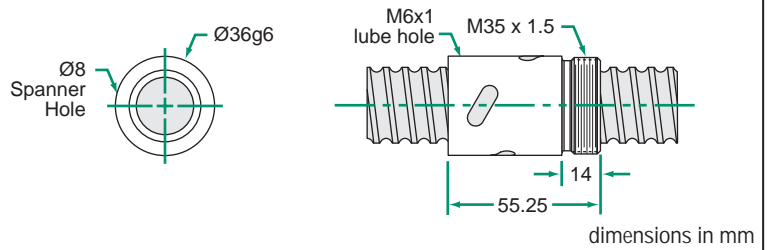

Flange - FLG10324

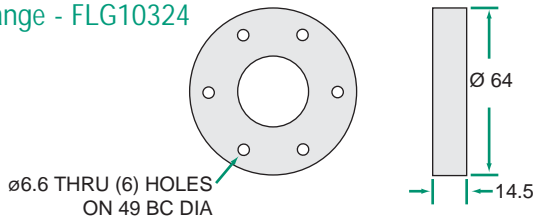

METRIC BALL SCREW AND NUT TECHNICAL DATA

20x5 PMT

LEAD ACCURACY: ±25µm/300mm

Single Start

- 20.71** Ball Circle Diameter
- 5** Lead
- 17.5** Root Diameter
- 3.175** Nominal Ball Diameter
- 2,170** Screw Mass (g/m)

Available Screw Length	PART NUMBERS
up to 7 M	20x5PMT
Custom cut lengths available up to 7M. For longer lengths contact customer service.	

MPN Preloaded Flanged Internal Return Ball Nut

PRODUCT SPECIFICATIONS	RH
Dynamic Load C_a (kN)	7.2
Static Load C_{0a} (kN)	12.2
Torque to Raise 1 kN (N·m)	.88
Nut Weight (g)	307
Spring Rate (kN/µm)	.28
Ball Nut Number	MPN10332
Flange	INTEGRAL
Wiper Type	ELASTOMER

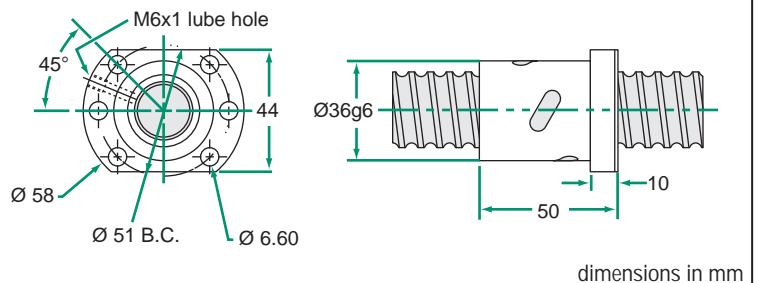

20mm Carry™ METRIC THREAD

LEAD ACCURACY: ±100µm/300mm

Carry Type Z Ball Nut

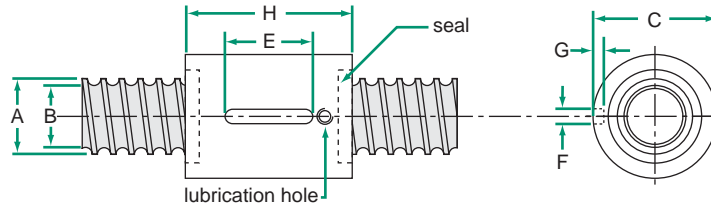

dimensions in mm

SCREW SPECIFICATIONS						NUT SPECIFICATIONS												
dia x lead	helix	reference number*	A	B root dia	wgt. (g/m)	part number	C	H	E	F	G	lash	wiper**	ball return location	wgt. (g)	torque to raise 1 kN (N·m)	load rating (N)	
																	Dyn. (C _a)	Static (C _{0a})
20 x 5	RH,LH	ECS-20050-□A	19.5	16.5	2014	ECN-20050-□ZU	33	45	20	4	2.5	0.07	Plastic	Internal	131	0.889	10800	25000

*Lengths available up to 3,000 mm. See page 154 and 174 to complete reference number **All nuts with wiper feature an M5 lubrication hole.

Carry Type FG Ball Nut

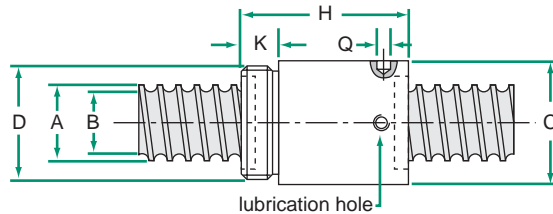

dimensions in mm

SCREW SPECIFICATIONS						NUT SPECIFICATIONS												
dia x lead	helix	reference number*	A	B root dia	wgt. (g/m)	part number	C	D	H	K	Q	lash	wiper**	ball return location	wgt. (g)	torque to raise 1 kN (N·m)	load rating (N)	
																	Dyn. (C _a)	Static (C _{0a})
20 x 5	RH,LH	ECS-20050-□A	19.5	16.5	2014	ECN-20050-□GU	32.2	M30x1.5	47	12	4	0.07	Plastic	Internal	120	0.889	10800	25000
20 x 10	RH	ECS-20010-□A	19.5	16.5	2014	ECN-20010-RG□	38	M35x1.5	58	19	4	0.07	Brush	External	250	1.778	21000	54000

*Lengths available up to 3,000 mm. See page 154 and 174 to complete reference number **All nuts with wiper feature an M5 lubrication hole.

Carry Type FB Ball Nut

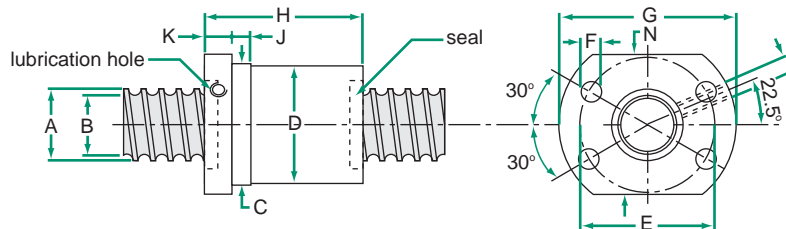

dimensions in mm

SCREW SPECIFICATIONS						NUT SPECIFICATIONS																	
dia x lead	helix	reference number*	A	B root dia	wgt. (g/m)	part number	C	D	E	F	G	H	J	K	N	P	lash	wiper**	ball return location	wgt. (g)	torque to raise 1 kN (N·m)	load rating (N)	
																						Dyn. (C _a)	Static (C _{0a})
20 x 5	RH,LH	ECS-20050-□A	19.5	16.5	2014	ECN-20050-□BU	36	35.5	47	6.6	58	50	10	10	44	M6	0.07	Plastic	Internal	283	0.889	10800	25000
20 x 10	RH	ECS-20010-RA	19.5	16.5	2014	ECN-20010-RBU	38	37.5	50	6.6	62	55	7	10	48	M6	0.07	Brush	Internal	250	1.778	21000	51000

*Lengths available up to 3,000 mm. See page 154 and 174 to complete reference number **All nuts with wiper feature an M5 lubrication hole.

METRIC BALL SCREW AND NUT TECHNICAL DATA

25x5 MRT

LEAD ACCURACY: ±100µm/300mm

Single Start

- 25.75** Ball Circle Diameter
- 5** Lead
- 22.6** Root Diameter
- 3.175** Nominal Ball Diameter
- 3,452** Screw Mass (g/m)

Available Screw Length	PART NUMBERS
	RH
up to 7 M	25x5MRT
Custom cut lengths available up to 7M. For longer lengths contact customer service.	

MBN Internal Return Ball Nut

PRODUCT SPECIFICATIONS	RH
Dynamic Load C_a (kN)	18.5
Static Load C_{0a} (kN)	39.4
Torque to Raise 1 kN (N·m)	.88
Nut Weight (g)	280
Ball Nut Number	MBN10281
Flange Part Number	FLG10289
Wiper Type	ELASTOMER

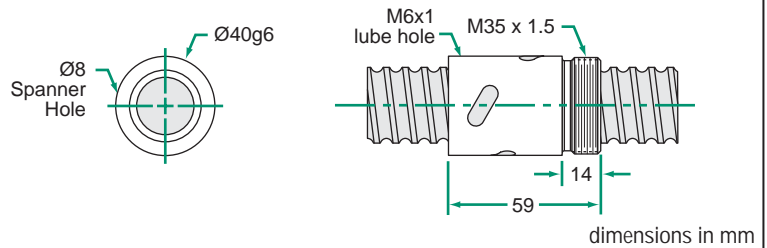

Flange - FLG10289

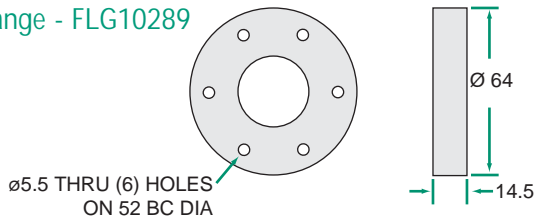

METRIC BALL SCREW AND NUT TECHNICAL DATA

25x5 PMT

LEAD ACCURACY: ±25µm/300mm

Single Start

- 25.75** Ball Circle Diameter
- 5** Lead
- 22.6** Root Diameter
- 3.175** Nominal Ball Diameter
- 3,452** Screw Mass (g/m)

Available Screw Length	PART NUMBERS
	RH
up to 7 M	25x5PMT
Custom cut lengths available up to 7M. For longer lengths contact customer service.	

MPN Preloaded Flanged Internal Return Ball Nut

PRODUCT SPECIFICATIONS	RH
Dynamic Load C_a (kN)	8.4
Static Load C_{0a} (kN)	15.7
Torque to Raise kN (N·m)	.88
Spring Rate (kN/µm)	.35
Nut Weight (g)	340
Ball Nut Number	MPN10333
Flange	INTEGRAL
Wiper Type	ELASTOMER

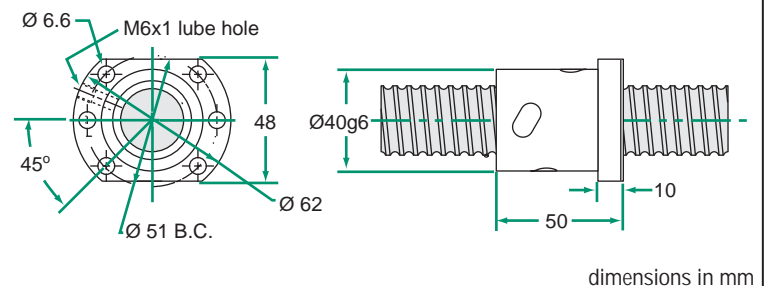

LEAD ACCURACY: ±100µm/300mm **25mm Carry™ METRIC THREAD**

Carry Type Z Ball Nut

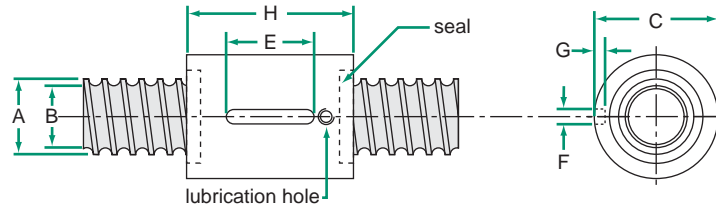

dimensions in mm

SCREW SPECIFICATIONS						NUT SPECIFICATIONS												
dia x lead	helix	reference number*	A	B root dia	wgt. (g/m)	part number	C	H	E	F	G	lash	wiper**	ball return location	wgt. (g)	torque to raise 1 kN (N·m)	load rating (N)	
																	Dyn. (C _a)	Static (C _{oa})
25 x 5	RH	ECS-25050-RA	24.6	21.5	2400	ECN-25050-RZU	38	50	20	4	2.5	0.07	Plastic	Internal	165	0.889	11700	30000

*Lengths available up to 3,000 mm. See page 154 and 174 to complete reference number **All nuts with wiper feature an M5 lubrication hole.

Carry Type FG Ball Nut

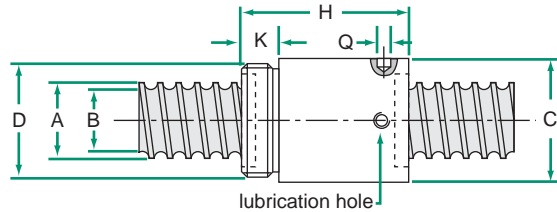

dimensions in mm

SCREW SPECIFICATIONS						NUT SPECIFICATIONS												
dia x lead	helix	reference number*	A	B root dia	wgt. (g/m)	part number	C	D	H	K	Q	lash	wiper**	ball return location	wgt. (g)	torque to raise 1 kN (N·m)	load rating (N)	
																	Dyn. (C _a)	Static (C _{oa})
25 x 5	RH	ECS-25050-RA	24.6	21.5	2400	ECN-25050-RGU	40	M38x1.5	57	12	4	0.07	Plastic	Internal	227	0.889	11700	30000
25 x 10	RH	ECS-25100-RA	24.8	21.8	2400	ECN-25100-RG□	43	M40x1.5	58	19	4	0.07	Brush	External	300	1.778	21000	51000
25 x 25	RH	ECS-25250-RA	24.5	21.2	3348	ECN-25250-RGU	44	M40x1.5	72	20	4	0.08	Brush	External	420	2.235	10000	24000
25 x 25	RH	ECS-25250-RA	24.5	21.2	3348	ECN-25250-RDU	44	M40x1.5	72	20	4	0.08	Brush	External	444	2.235	20000	48000

*Lengths available up to 3,000 mm. See page 154 and 174 to complete reference number **All nuts with wiper feature an M5 lubrication hole.

Carry Type FB Ball Nut

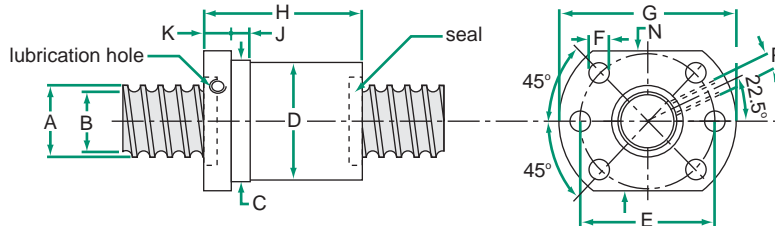

dimensions in mm

SCREW SPECIFICATIONS						NUT SPECIFICATIONS																	
dia x lead	helix	reference number*	A	B root dia	wgt. (g/m)	part number	C	D	E	F	G	H	J	K	N	P	lash	wiper**	ball return location	wgt. (g)	torque to raise 1 kN (N·m)	load rating (N)	
																					Dyn. (C _a)	Static (C _{oa})	
25 x 5	RH	ECS-25050-RA	24.6	21.5	2400	ECN-25050-RBU	40	39.5	51	6.6	62	50	10	10	48	M6	0.07	Plastic	Internal	292	0.889	11700	30000
25 x 5	RH	ECS-25050-RA	24.6	21.5	2400	ECN-25050-RJU	40	39.5	51	6.6	62	55	10	10	48	M6	0.07	Plastic	Internal	309	0.889	14000	35000
25 x 10	RH	ECS-25100-RA	24.8	21.9	2400	ECN-25100-RBU	43	42.5	55	6.6	65	55	7	10	50	M6	0.07	Brush	External	440	1.778	21000	54000
25 x 25	RH	ECS-25250-RA	24.5	21.2	3348	ECN-25250-RBU	44	43.5	56	6.6	70	67	10	12	52	M6	0.08	Brush	External	500	4.420	10000	24000

*Lengths available up to 3,000 mm. See page 154 and 174 to complete reference number **All nuts with wiper feature an M5 lubrication hole.

† This size only available with nut styles: B, A and C ‡ This size available with nut styles J, K, and L

32mm Carry™ METRIC THREAD

LEAD ACCURACY: ±100µm/300mm

Carry Type Z Ball Nut

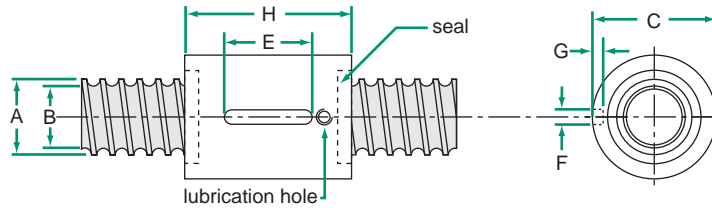

dimensions in mm

SCREW SPECIFICATIONS						NUT SPECIFICATIONS												
dia x lead	helix	reference number*	A	B root dia	wgt. (g/m)	part number	C	H	E	F	G	lash	wiper**	ball return location	wgt. (g)	torque to raise 1 kN (N·m)	load rating (N)	
																	Dyn. (C _a)	Static (C _{0a})
32 x 5	RH	ECS-32050-RA	29.6	26.6	5660	ECN-32050-RZU	48	48	20	5	3.0	0.07	Plastic	Internal	258	0.889	19000	54000

*Lengths available up to 3,000 mm. See page 154 and 174 to complete reference number **All nuts with wiper feature an M5 lubrication hole.

Carry Type FG Ball Nut

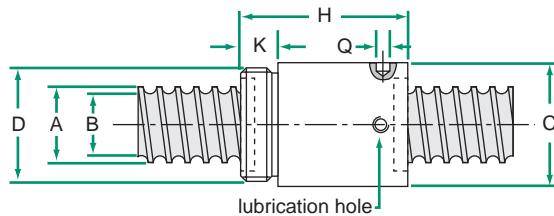

dimensions in mm

SCREW SPECIFICATIONS						NUT SPECIFICATIONS												
dia x lead	helix	reference number*	A	B root dia	wgt. (g/m)	part number	C	D	H	K	Q	lash	wiper**	ball return location	wgt. (g)	torque to raise 1 kN (N·m)	load rating (N)	
																	Dyn. (C _a)	Static (C _{0a})
32 x 5	RH	ECS-32050-RA	29.6	26.6	5660	ECN-32050-RGU	52	M48x1.5	55	15	4	0.07	Plastic	Internal	381	0.889	19000	54000

*Lengths available up to 3,000 mm. See page 154 and 174 to complete reference number **All nuts with wiper feature an M5 lubrication hole.

Carry Type FB Ball Nut

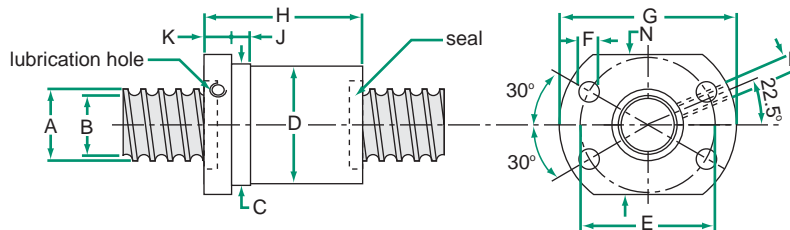

dimensions in mm

SCREW SPECIFICATIONS						NUT SPECIFICATIONS																	
dia x lead	helix	reference number*	A	B root dia	wgt. (g/m)	part number	C	D	E	F	G	H	J	K	N	P	lash	wiper**	ball return location	wgt. (g)	torque to raise 1 kN (N·m)	load rating (N)	
																						Dyn. (C _a)	Static (C _{0a})
32 x 5	RH	ECS-32050-RA	29.6	26.6	5660	ECN-32050-R□U	50	49.5	65	9.0	80	57	10	12	62	M6	0.07	Plastic	Internal	560	0.889	19000	54000

*Lengths available up to 3,000 mm. See page 154 and 174 to complete reference number **All nuts with wiper feature an M5 lubrication hole.

METRIC BALL SCREW AND NUT TECHNICAL DATA

Available Screw Length	PART NUMBERS
	RH
up to 7 M	40x10MRT
Custom cut lengths available up to 7M. For longer lengths contact customer service.	

40x10 MRT

LEAD ACCURACY: ±100µm/300mm

Single Start

- 42.1** Ball Circle Diameter
- 10** Lead
- 34.79** Root Diameter
- 7.144** Nominal Ball Diameter
- 8,566** Screw Mass (g/m)

MBN Internal Return Ball Nut

PRODUCT SPECIFICATIONS	RH
Dynamic Load C_a (kN)	62.5
Static Load C_{oa} (kN)	136.2
Torque to Raise 1 kN (N·m)	1.778
Nut Weight (g)	1177
Ball Nut Number	MBN10291
Flange Part Number	FLG10301
Wiper Type	ELASTOMER

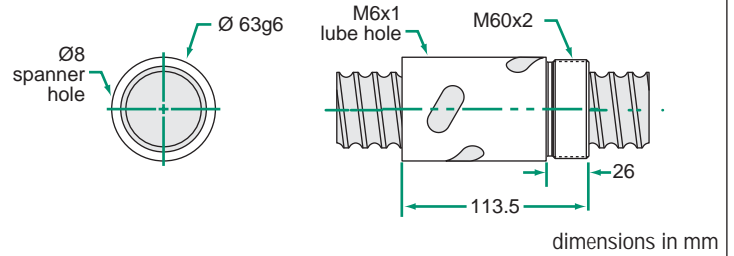

Flange - FLG10301

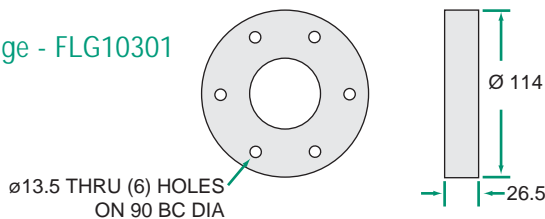

Available Screw Length	PART NUMBERS
	RH
up to 7 M	40x10PMT
Custom cut lengths available up to 7M. For longer lengths contact customer service.	

40x10 PMT

LEAD ACCURACY: ±25µm/300mm

Single Start

- 42.1** Ball Circle Diameter
- 10** Lead
- 34.79** Root Diameter
- 7.144** Nominal Ball Diameter
- 8,566** Screw Mass (g/m)

MPN Preloaded Flanged Internal Return Ball Nut

PRODUCT SPECIFICATIONS	RH
Dynamic Load C_a (kN)	28.4
Static Load C_{oa} (kN)	54.5
Torque to Raise 1 kN (N·m)	1.778
Nut Weight (g)	1182
Spring Rate (kN/µm)	.55
Ball Nut Number	MPN10305
Flange	INTEGRAL
Wiper Type	ELASTOMER

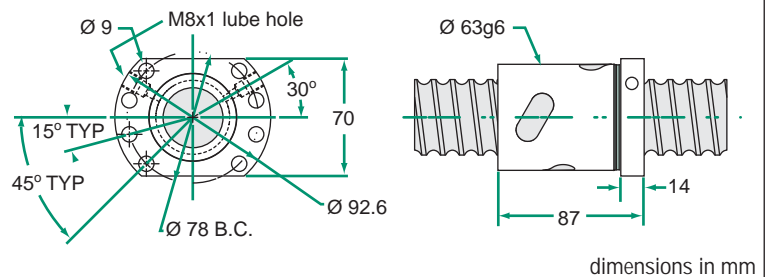

40x40 MRT

LEAD ACCURACY: ±100µm/300mm

Single Start

- 40.28** Ball Circle Diameter
- 40** Lead
- 33.79** Root Diameter
- 6.35** Nominal Ball Diameter
- 8,315** Screw Mass (g/m)

Available Screw Length	PART NUMBERS
	RH
up to 7 M	40x40 MRT
Custom cut lengths available up to 7M. For longer lengths contact customer service.	

MBN Internal Return Ball Nut

PRODUCT SPECIFICATIONS	RH
Dynamic Load C_a (kN)	75.30
Static Load C_{0a} (kN)	121.40
Torque to Raise 1 kN (N-m)	7.08
Nut Weight (g)	1.800
Ball Nut Number	MBN10427
Flange Part Number	FLG10428
Wiper Type	PLASTIC

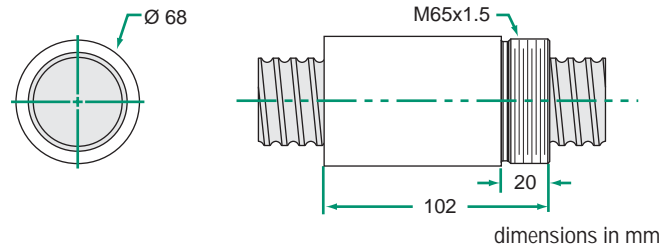

Flange - FLG10428

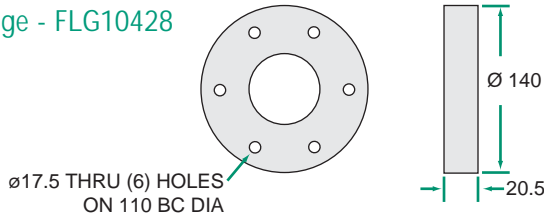

METRIC BALL SCREW AND NUT TECHNICAL DATA

40x40 MRT

LEAD ACCURACY: ±100µm/300mm

Single Start

- 40.28** Ball Circle Diameter
- 40** Lead
- 33.79** Root Diameter
- 6.35** Nominal Ball Diameter
- 8,315** Screw Mass (g/m)

Available Screw Length	PART NUMBERS
	RH
up to 7 M	40x40 MRT
Custom cut lengths available up to 7M. For longer lengths contact customer service.	

MPN Internal Return Ball Nut with Integral Flange

PRODUCT SPECIFICATIONS	RH
Dynamic Load C_a (kN)	75.30
Static Load C_{0a} (kN)	121.40
Torque to Raise 1 kN (N-m)	7.08
Nut Weight (g)	1.560
Ball Nut Number	MPN10429
Flange	INTEGRAL
Wiper Type	PLASTIC

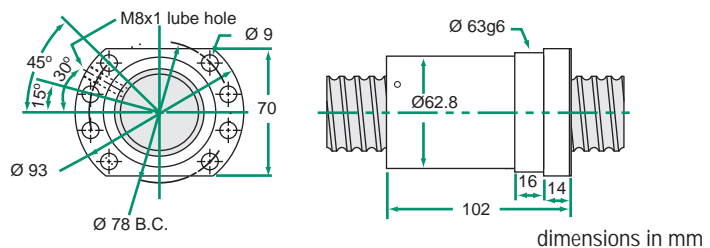

Available Screw Length	PART NUMBERS
	RH
up to 7 M	50x10MRT
Custom cut lengths available up to 7M. For longer lengths contact customer service.	

50x10 MRT

LEAD ACCURACY: ±100µm/300mm

Single Start

51.7 Ball Circle Diameter
10 Lead
45.2 Root Diameter
6.35 Nominal Ball Diameter
13,880 Screw Mass (g/m)

MBN Internal Return Ball Nut

PRODUCT SPECIFICATIONS	RH
Dynamic Load C_a (kN)	75.5
Static Load C_{0a} (kN)	189.3
Torque to Raise 1 kN (N·m)	1.778
Nut Weight (g)	1952
Ball Nut Number	MBN10285
Flange Part Number	FLG10290
Wiper Type	ELASTOMER

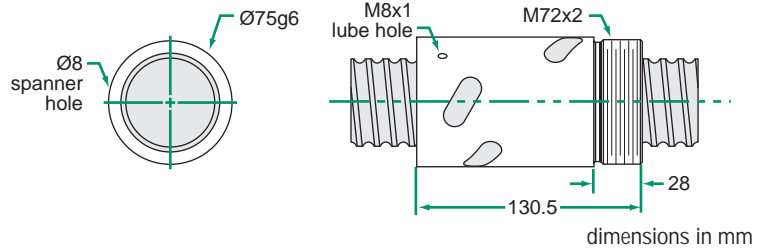

Flange - FLG10290

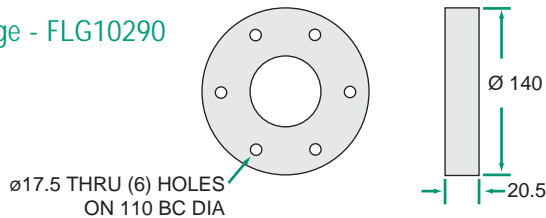

Available Screw Length	PART NUMBERS
	RH
up to 7 M	50x10PMT
Custom cut lengths available up to 7M. For longer lengths contact customer service.	

50x10 PMT

LEAD ACCURACY: ±25µm/300mm

Single Start

51.7 Ball Circle Diameter
10 Lead
45.2 Root Diameter
6.35 Nominal Ball Diameter
13,880 Screw Mass (g/m)

MPN Preloaded Flanged Internal Return Ball Nut

PRODUCT SPECIFICATIONS	RH
Dynamic Load C_a (kN)	41.6
Static Load C_{0a} (kN)	94.6
Torque to Raise 1 kN (N·m)	1.778
Nut Weight (g)	2328
Spring Rate (kN/µm)	.97
Ball Nut Number	MPN10334
Flange	INTEGRAL
Wiper Type	ELASTOMER

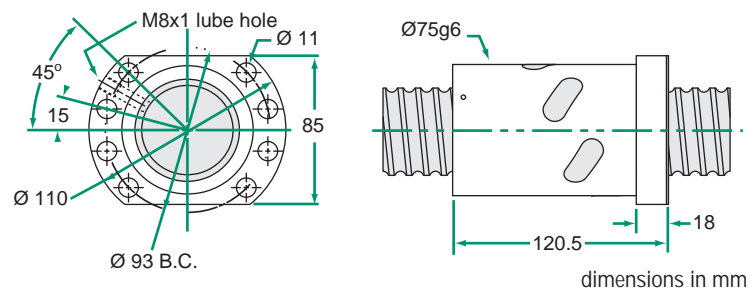

50x50 MRT

LEAD ACCURACY: ±100µm/300mm

Single Start

- 49.50** Ball Circle Diameter
- 50** Lead
- 43.02** Root Diameter
- 6.35** Nominal Ball Diameter
- 13,900** Screw Mass (g/m)

Available Screw Length	PART NUMBERS
	RH
up to 7 M	50x50 MRT
Custom cut lengths available up to 7M. For longer lengths contact customer service.	

MBN Internal Return Ball Nut

PRODUCT SPECIFICATIONS	RH
Dynamic Load C_a (kN)	92.60
Static Load C_{0a} (kN)	152.40
Torque to Raise 1 kN (N·m)	7.08
Nut Weight (g)	3400
Ball Nut Number	MBN10430
Flange Part Number	FLG10431
Wiper Type	PLASTIC

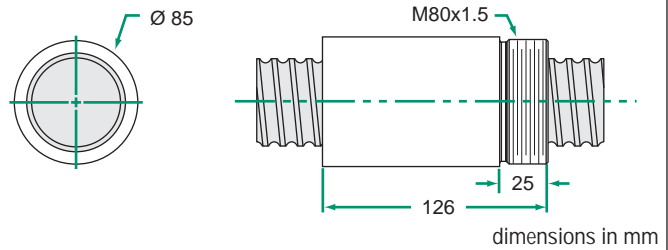

Flange - FLG10431

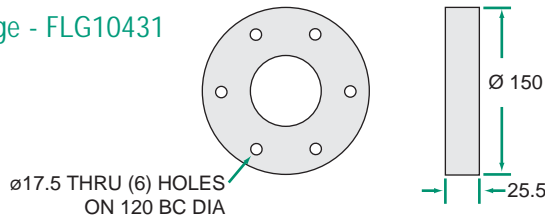

METRIC BALL SCREW AND NUT TECHNICAL DATA

50x50 MRT

LEAD ACCURACY: ±100µm/300mm

Single Start

- 49.50** Ball Circle Diameter
- 50** Lead
- 43.02** Root Diameter
- 6.35** Nominal Ball Diameter
- 13,900** Screw Mass (g/m)

Available Screw Length	PART NUMBERS
	RH
up to 7 M	50x50 MRT
Custom cut lengths available up to 7M. For longer lengths contact customer service.	

MPN Preloaded Flanged Internal Return Ball Nut

PRODUCT SPECIFICATIONS	RH
Dynamic Load C_a (kN)	92.60
Static Load C_{0a} (kN)	152.40
Torque to Raise 1 kN (N·m)	7.08
Nut Weight (g)	2950
Ball Nut Number	MPN10432
Flange	INTEGRAL
Wiper Type	PLASTIC

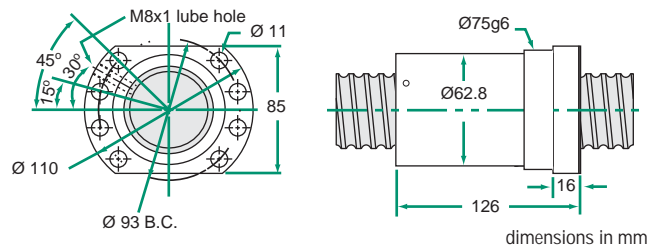

Available Screw Length	PART NUMBERS
	RH
up to 7 M	63x12MRT
Custom cut lengths available up to 7M. For longer lengths contact customer service.	

63x12 MRT

LEAD ACCURACY: ±100µm/300mm

Single Start

- 65.1** Ball Circle Diameter
- 12** Lead
- 56.98** Root Diameter
- 7.94** Nominal Ball Diameter
- 22,046** Screw Mass (g/m)

MBN Double Circuit Ball Nut	
PRODUCT SPECIFICATIONS	RH
Dynamic Load C_a (kN)	140
Static Load C_{oa} (kN)	386
Torque to Raise kN (N·m)	2.124
Nut Weight (g)	4451
Ball Nut Number	MBN10297
Flange Part Number	FLG10307
Wiper Kit Part Number	—

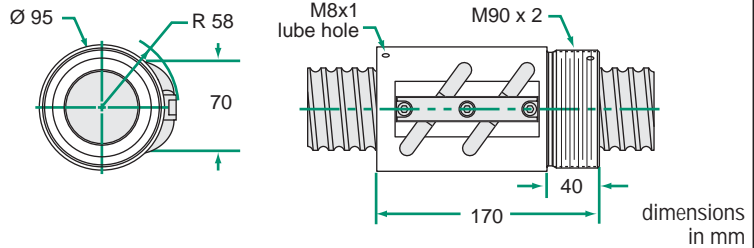

Flange - FLG10307

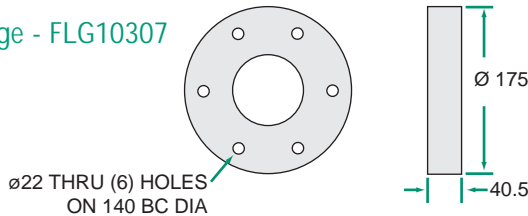

Available Screw Length	PART NUMBERS
	RH
up to 7 M	63x12PMT
Custom cut lengths available up to 7M. For longer lengths contact customer service.	

63x12 PMT

LEAD ACCURACY: ±25µm/300mm

Single Start

- 65.1** Ball Circle Diameter
- 12** Lead
- 56.98** Root Diameter
- 7.94** Nominal Ball Diameter
- 22,046** Screw Mass (g/m)

MPN Preloaded Flanged Ball Nut	
PRODUCT SPECIFICATIONS	RH
Dynamic Load C_a (kN)	76.91
Static Load C_{oa} (kN)	193
Torque to Raise kN (N·m)	2.124
Nut Weight (g)	4915
Spring Rate (kN/µm)	1.52
Ball Nut Number	MPN10335
Flange	INTEGRAL
Wiper Type	—

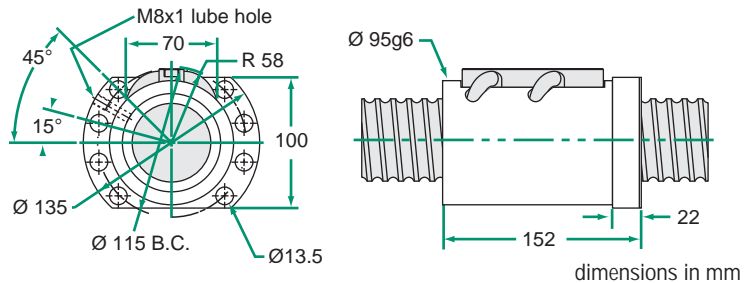

METRIC BALL SCREW AND NUT TECHNICAL DATA

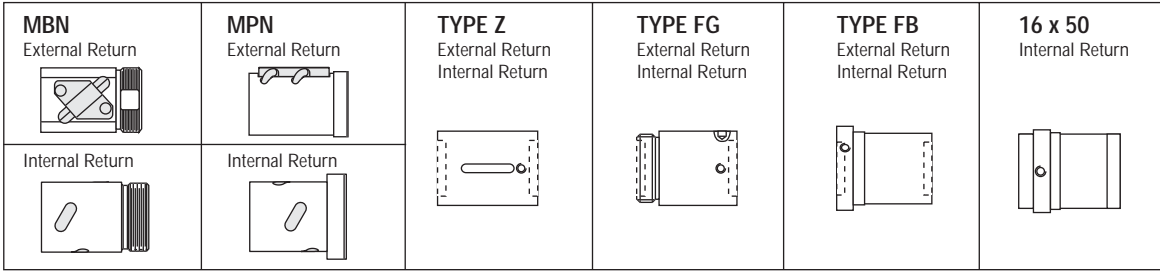

METRIC BALL SCREW AND NUT TECHNICAL DATA

SCREW SELECTION										NUT SELECTION														Page Ref				
DIA x LEAD	Root Dia. (mm)	MRT RH	* PMT RH	CARRY				LOAD RATING (N)		Torque To Raise 1kN(N·m)	MBN	MPN	Z				FG				FB							
				Alloy		SS		Dynamic Ca	Static Coa		Alloy	MPN	Alloy		SS		Alloy		SS		Alloy		SS					
				RH	LH	RH	LH				RH	LH	RH	LH	RH	LH	RH	LH	RH	LH	RH	LH	RH		LH			
6 x 1	5.0			●				600	1,000	0.178			●	●														155
8 x 1	7.0			●				700	1,200	0.178			●															156
8 x 1.5	6.7			●		●		800	1,300	0.254			●	●		●	●											156
8 x 2	6.5			●				2,000	3,200	0.356			●								●	●						156
8 x 2.5	6.6			●		●		2,000	3,200	0.432			●			●	●											156
8 x 3	6.7			●				950	1,500	0.533			●			●												156
10 x 2	8.2			●				1,250	2,100	0.356			●			●												157
10 x 3	7.8			●	●	●		2,800	5,000	0.541			●	●		●	●											157
12 x 2	10.6			●				1,380	2,500	0.356			●			●												158
12 x 4	9.8			●		●		5,500	11,000	0.711			●			●	●				●							158
12 x 5	9.5			●		●		6,600	12,000	0.889			●			●					●							158
12.7 x 12.7	10.3			●				8,000	15,500	2.235			●			●												158
14 x 4	11.5			●	●			8,100	16,000	0.711			●	●		●	●				●	●						159
16 x 2	14.5			●				2,500	5,500	0.356			●			●					●							162
16 x 5	12.9	●	●					7,600	12,400	0.880	●	●																160
16 x 5	13.0			●				9,700	22,000	0.889			●			●					●							162
16 x 10	13.0			●				17,000	25,000	1.778			●			●					●							162
16 x 50	10.6			●				4,500	10,000	8.839			●												●			161
20 x 5	17.5	●	●					13,000	24,400	0.880	●	●																164
20 x 5	16.5			●	●			10,800	25,000	0.889			●	●		●	●				●	●						165
20 x 10	16.5			●				21,000	51,000	1.778			●			●					●							165
25 x 5	22.6	●	●					18,500	39,400	0.880	●	●																166
25 x 5	21.5			●				11,700	30,000	0.889			●			●					●							167
25 x 10	21.8			●				21,000	51,000	1.778			●			●					●							167
25 x 25	21.2			●				10,000	24,000	4.420			●			●					●							167
32 x 5	26.6			●				19,000	54,000	0.889			●			●					●							168
40 x 10	34.79	●	●					62,500	136,200	1.778	●	●																169
40 x 40	33.79	●						75,300	121,400	7.08	●	●																170
50 x 10	45.2	●	●					75,500	189,300	1.778	●	●																171
50 x 50	43.02	●						92,600	152,400	7.08	●	●																172
63 x 12	56.98	●	●					140,000	386,000	2.124	●	●																173

*PMT load rating is different from MRT, see previous pages for specific nut load ratings.