



These definitions/descriptions are for the Product Specifications listed on the Electric Cylinder pages. Additional technical information on the preceding

pages is designed to help in selecting the cylinder that is best for the application. For additional assistance please contact Nook Industries.

**DD & RAD CYLINDERS**

**Model Type and Number** See page 389 for reference number configuration information.

**Travel Rate** Measured in inches per minute at full dynamic load.

**Dynamic Capacity** Measured in pounds.

**Rated Life** Measured in millions of inches (ball screw models only). Based on the ball screw cylinder only dynamic capacity.

**Standard Motor HP Rating** See page 377 for additional motor information.

**Standard Brake Torque** Measured in (pound-feet).

**Approximate Stopping Distance** These values are used when initially setting the limit switches. Stopping distances are approximate. Large inertia forces, such as loads moved at high speed supported on anti-friction guides may affect stopping distance. **INERTIAL LOADS SHOULD BE EVALUATED TO BE SURE IT DOES NOT EXCEED THE UNITS DYNAMIC CAPACITY.**

**Max Rod Reaction Torque** Based on full dynamic load. Torque will be proportionally lower for lower loads.

**Basic Weight** See specific units for weight. These weights do not include motor weight.

ELECTRIC CYLINDER SUMMARY

RAD-25 BALL SCREW MODELS									
MODEL NUMBER	TRAVEL RATE [in./min.]	DYNAMIC CAPACITY [lb.]	RATED LIFE [in. x 10 <sup>6</sup> ]	STD. MOTOR HP RATING [ref.]	STD. BRAKE TORQUE [ft.-lb.]	APPROX. STOPPING DISTANCE [in.]		MAXIMUM ROD REACTION TORQUE [in.-lb.]	BASIC WEIGHT [lbs.]
						No Load	Full Load		
RAD-2566-HL / 10XX	48	3,550	.22	1	6	.08	.08	628	46
RAD-2562-HL / 10XX	24	5,000	.08	1	6	.04	.04	885	46
RAD-2566-ML / 05XX	24	5,000	.33	.5	3	.014	.014	443	46
RAD-2562-HD / 03XX	6	5,000	.03	.33	3	.007	.007	221	46
RAD-2546-HD / 02XX	3	5,000	.03	.25	3	.003	.003	221	46

**DD & RAD CYLINDERS CONTINUED**

**Length Notation** to determine standard extended and retracted length use the formula for each specific model/capacity. For special retracted lengths please contact Nook. **WARNING!** Any change to standard lengths may compromise the cylinder's compression load carrying capacity.

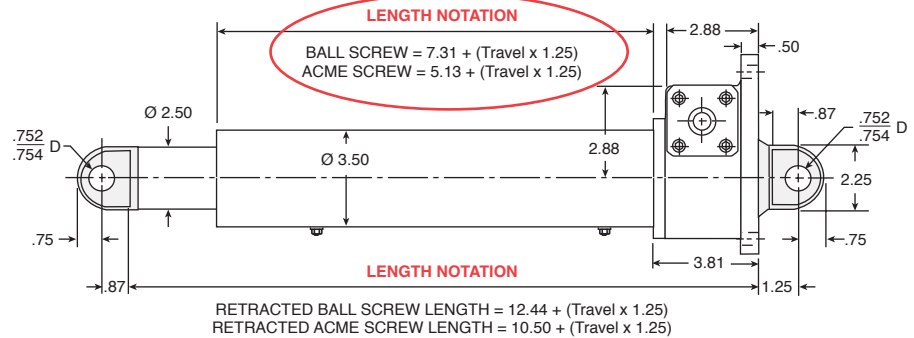

ELECTRIC CYLINDER SUMMARY

**ILA CYLINDERS**

**Model Type and Number** See page 402 for reference number configuration information.

**Max Load** Thrust capacity Measured in pounds.

**Max Input Torque** Measured in (inch-pounds)

**Max Travel Rate** Measured in inches per minute

**Ball Screw** See individual ball screw page for screw specifications. Lead accuracy of 0.004"/ft.

**Torque Per lb.** Torque, in inch-pounds, required to generate one pound of output force. This is also the rod reaction torque.

\* DIMENSION BASED ON MOTOR MOUNT, contact factory with your specific requirements.

ILA-25 & ILAK-25 BALL SCREW MODELS							
MODEL NUMBER	MAXIMUM LOAD [lb.]	MAX. INPUT TORQUE [in.-lb.]	MAX. TRAVEL RATE [in./min.]	BALL SCREW	TORQUE PER LB. [in.-lb.]	DIMENSIONS	
						A	B
ILA-25 HL	2,200	390	3,000	1000-1000 SRT	0.177	3.00	1.50
ILA-25-ML	3,500	308	1,500	1000-0500 SRT	0.088	3.00	1.50
ILA-25-HD	3,500	154	750	1000-0250 SRT	0.035	3.00	1.50
ILAK-25 HL (Keyed)	2,200	390	3,000	1000-1000 SRT	0.177	4.00	1.25
ILAK-25-ML (Keyed)	3,500	308	1,500	1000-0500 SRT	0.088	4.00	1.25
ILAK-25-HD (Keyed)	3,500	154	750	1000-0250 SRT	0.035	4.00	1.25

**ROD REACTION TORQUE** = TORQUE PER LB. x LOAD

**NOTE:** CYLINDER IS SELF-LOWERING. INPUT SHAFT MUST BE SECURED TO PREVENT ROTATION.

## ACTIONJAC™ ELECTRIC CYLINDERS

ActionJac™ Electric Cylinders are ruggedly designed and produced in standard models with thrust capacities from 500 lbs. to 40,000 lbs. Electric Cylinders are intended for use in industrial environments and feature ground and hard chrome plated actuator tubes with epoxy paint on exterior surfaces. Electric Cylinders can be supplied for outdoor applications.

These cylinders may be used individually or in multiple arrangements. Each ActionJac™ Electric Cylinder is built to specification.

### ACCESSORIES

Accessories such as motors, motor mounts, encoders, hand wheels, counters, couplings, miter gear boxes, boots, limit switches, clevises, clevis pins and clevis brackets are available.



# RAD-2566-HL / 10BT-1 / 2CA-4C / CC / 24.5 / SER

## SERIES 100 OR 200 MODEL

Refer to pages 357 to 359 for available models.

## FIRST SHAFT EXTENSION

- SSE-1** = Standard Shaft Extension, Position 1
- SSE-2** = Standard Shaft Extension, Position 2
- 000-1** = Delete Shaft Extension, Position 1
- 000-2** = Delete Shaft Extension, Position 2

POSITION (see page 376)  
ORDER CODE

**Input Shaft (CCW)**  
Positions 1, 3, 5, 7

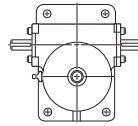

**Input Shaft (CW)**  
Positions 2, 4, 6, 8

## SHAFT ORDER CODE

CCW Position 1  
CW Position 2

## ORDER CODES (Must Include A Position)

### NO ACCESSORY

- SSE-\_\_** = Standard Shaft Extension, Position 1 or 2
- 000-\_\_** = Delete Shaft Extension, Position 1 or 2
- SPC-\_\_** = Special Modified Shaft Extension, Position 1 or 2

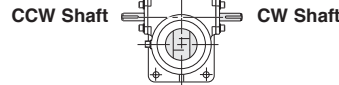

### Motor Mounts Without Motor

For DD, position 1 or 2  
For RAD, position 1 through 8

see page 376 for standard  
motor mount order codes

### Motor Mounts With Motors

For DD, position 1 or 2  
For RAD, position 1 through 8

see page 376 & 377  
for available motors

#### EXAMPLE:

**02BS-2** = 1/4 Hp-1 ph internally wired  
Brake Motor in Position 2

Used on DD-10 to DD-200

### Rotary Limit Switch

(Position 1 C or E  
through 8 C or E)

see page 380 and 381  
for available rotary limit switches

**NOTE:** A Limit Switch must include a  
close or extended mount.

#### EXAMPLE:

**4CA-6E** = 4 Circuit Limit Switch, SPDT  
with an extended mount in  
Position 6

Used on DD-25 to DD-200

**NOTE:** Both Shaft Extensions Must Be Specified

## SECOND SHAFT EXTENSION

Refer to First Shaft Extension Above.

**NOTE:** Both Shaft Extensions Must Be Specified

## HOUSING CONFIGURATION

**F** = Standard Flange Base      **C** = Clevis Base

## SCREW CONFIGURATION

**T** = Threaded End      **P** = Top Plate  
**C** = Clevis End  
**D** = Threaded rod end with female clevis installed

## TRAVEL

Travel in inches.

## MODIFIER LIST

### E, B and/or R

- E** = In-Line Encoder (See page 375)
- B** = Bellows Boots (See pages 280 – 281)
- R** = Rod Type Limit Switch (See page 382)

### Optional S or M Required

- S** = Standard, no additional description required
- M** = Modified, additional description required

**NOTE: NOT ALL OPTIONS AVAILABLE FOR ALL SIZES**

MOTOR MOUNT IS SHOWN  
IN POSITION 1  
Motor may be mounted  
to either side of cylinder  
(see page 376)

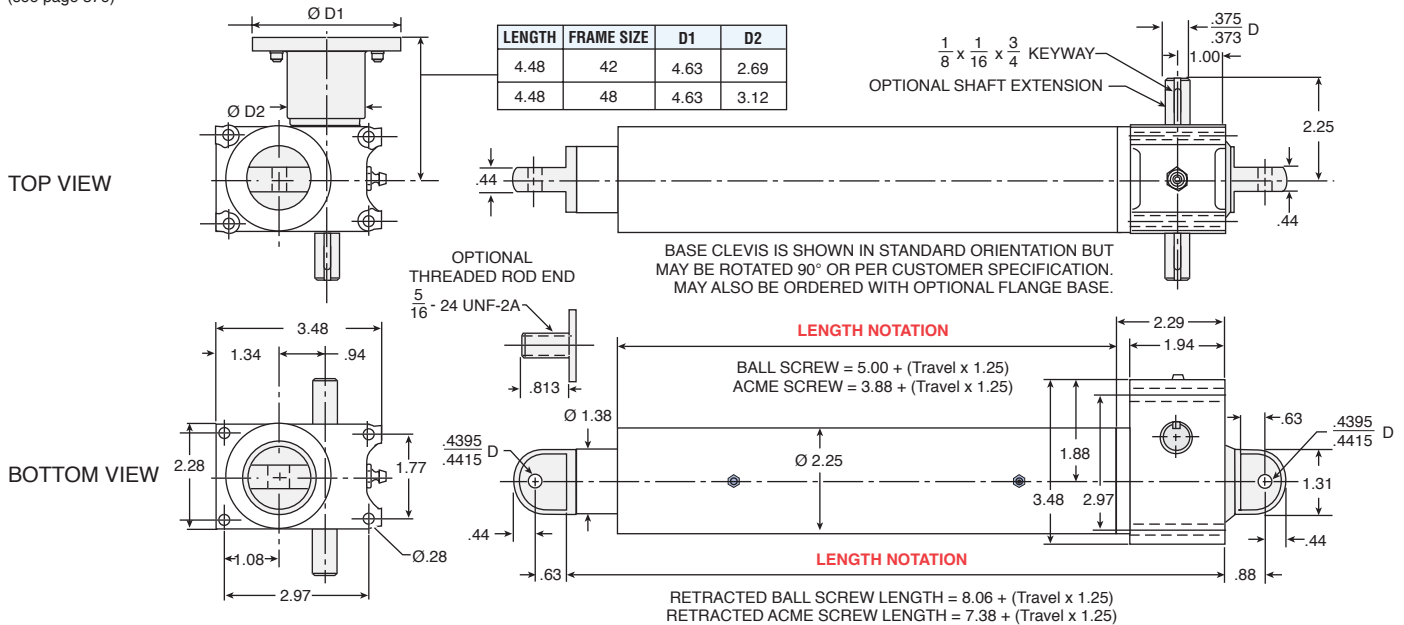

### DD-5 BALL SCREW MODELS

MODEL NUMBER	DYNAMIC CAPACITY [lb.]	RATED LIFE [in. x 10 <sup>6</sup> ]	MAX. MOTOR HP RATING [ref.]	MAXIMUM ROD REACTION TORQUE [in.-lb.]	BASIC WEIGHT [lbs.]
DD-55-HL / T03	1,000	6.9	.33	89	12
DD-520-HL / T06	1,000	4.1	.16	89	12
DD-55-HD / T03	1,000	.47	.33	35	12
DD-520-HD / T06	1,000	.47	.16	35	12

### DD-5 ACME SCREW MODELS

MODEL NUMBER	DYNAMIC CAPACITY [lbf.]	STD. MOTOR HP RATING [ref.]*	MAXIMUM ROD REACTION TORQUE [in.-lb.]	BASIC WEIGHT [lbs.]
DD-55-A5 / T03	1,000	.33	72	11
DD-55-A8 / T03	1,000	.33	58	11
DD-55-A10 / T03	1,000	.33	53	11
DD-520-A5 / T06	1,000	.16	72	11
DD-520-A8 / T06	1,000	.16	58	11
DD-520-A10 / T06	1,000	.16	53	11

\*no brake

#### BALL SCREW MODELS:

TOTAL WEIGHT =  $(0.65)T + \text{BASIC WEIGHT}$ , where T = TRAVEL IN INCHES

#### ACME SCREW MODELS:

TOTAL WEIGHT =  $(0.64)T + \text{BASIC WEIGHT}$ , where T = TRAVEL IN INCHES

**WARNING!** UNITS ARE NOT TO BE USED AS PERSONNEL SUPPORT OR MOVEMENT. BALL SCREW MODELS ARE SELF-LOWERING.

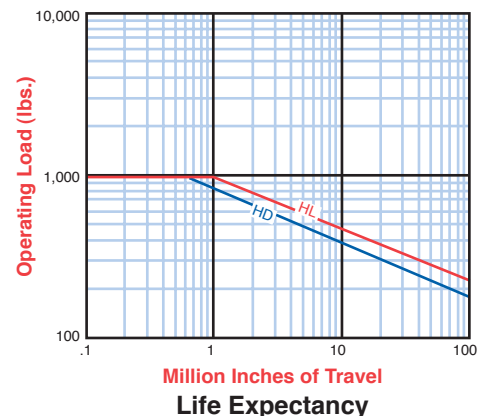
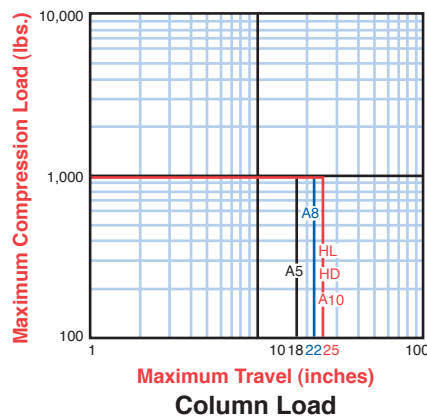

MOTOR MOUNT IS SHOWN  
IN POSITION 1  
Motor may be mounted  
to either side of cylinder  
(see page 376)

MOTOR DIMENSIONS (For most up-to-date detailed motor dimensions, see [www.nookindustries.com](http://www.nookindustries.com))

HP	FRAME SIZE	DIA	LENGTH
1/4-1/2	56	6.63	5.71

NOTE: Adapter plated added for NEMA 56 motors only

TOP VIEW

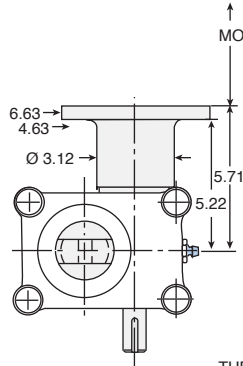

BOTTOM VIEW

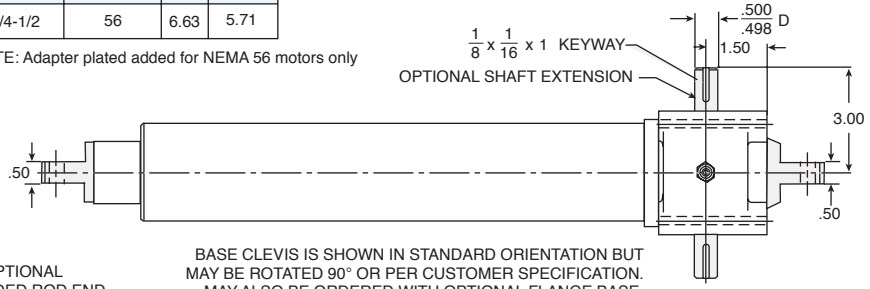
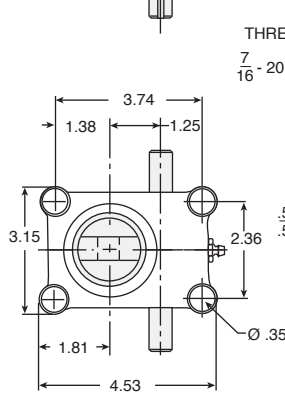

BASE CLEVIS IS SHOWN IN STANDARD ORIENTATION BUT  
MAY BE ROTATED 90° OR PER CUSTOMER SPECIFICATION.  
MAY ALSO BE ORDERED WITH OPTIONAL FLANGE BASE.

OPTIONAL  
THREADED ROD END

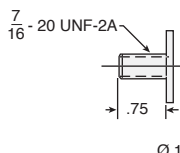

LENGTH NOTATION

BALL SCREW = 6.38 + (Travel x 1.25)  
ACME SCREW = 4.25 + (Travel x 1.25)

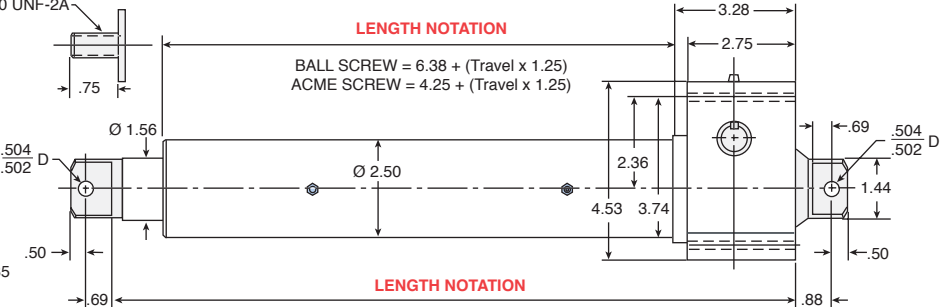

LENGTH NOTATION

RETRACTED BALL SCREW LENGTH = 10.75 + (Travel x 1.25)  
RETRACTED ACME SCREW LENGTH = 8.25 + (Travel x 1.25)

DD AND RAD ELECTRIC CYLINDERS

## DD-10 BALL SCREW MODELS

MODEL NUMBER	TRAVEL RATE [in./min.]	DYNAMIC CAPACITY [lb.]	RATED LIFE [in. x 10 <sup>6</sup> ]	STD. MOTOR HP RATING [ref.]	STD. BRAKE TORQUE [ft.-lb.]	APPROX. STOPPING DISTANCE [in.]		MAXIMUM ROD REACTION TORQUE [in.-lb.]	BASIC WEIGHT [lbs.]
						No Load	Full Load		
DD-105-HL / 05XX	173	750	46	.50	3	.20	.38	67	19
DD-1020-HL / 02XX	43	800	39	.25	3	.80	.15	71	19
DD-105-HD / 05XX	69	1900	.19	.50	3	.05	.06	67	19
DD-1020-HD / 02XX	17	2000	.17	.25	3	.02	.02	71	19

## DD-10 ACME SCREW MODELS

MODEL NUMBER	TRAVEL RATE [in./min.]	DYNAMIC CAPACITY [lbf.]	STD. MOTOR HP RATING [ref.]	STD. BRAKE TORQUE [ft.-lb.]	APPROX. STOPPING DISTANCE [in.] NO LOAD	MAXIMUM ROD REACTION TORQUE [in.-lb.]	BASIC WEIGHT [lbs.]
DD-1020-A5 / 02XX	17	900	.25	3	.02	84	15

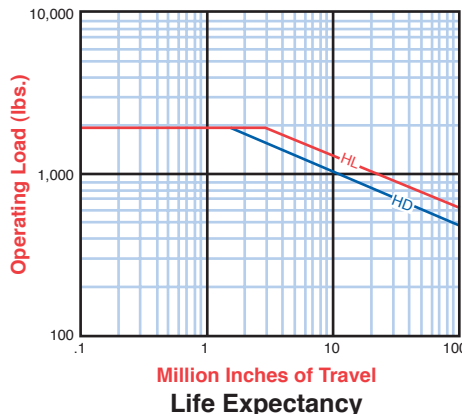
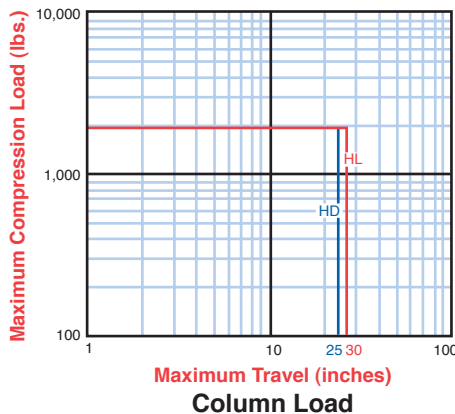

### BALL SCREW MODELS:

TOTAL WEIGHT = (0.77)T + BASIC WEIGHT, where T = TRAVEL IN INCHES

### ACME SCREW MODELS:

TOTAL WEIGHT = (0.76)T + BASIC WEIGHT, where T = TRAVEL IN INCHES

**WARNING!** UNITS ARE NOT TO BE USED AS PERSONNEL SUPPORT OR MOVEMENT. BALL SCREW MODELS ARE SELF-LOWERING.

MOTOR IS SHOWN  
IN POSITION 1  
Motor may be mounted  
to either side of cylinder  
(see page 376)

MOTOR DIMENSIONS  
(For most up-to-date detailed motor  
dimensions, see www.nookindustries.com)

HP	DIA	FRAME SIZE
1/4-2	6.62	56C

HP	LENGTH	FRAME SIZE
1/4-2	6.25	56C

TOP VIEW

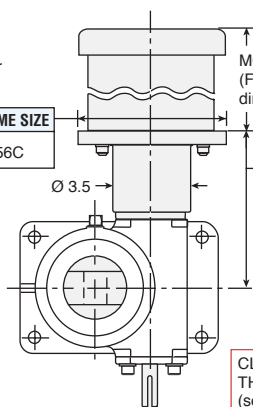

CLEVIS END STD.  
THREADED END OPT.  
(see page 393)

THE DIMENSIONS ON THESE VIEWS  
ARE COMMON TO BOTH DD & RAD MODELS

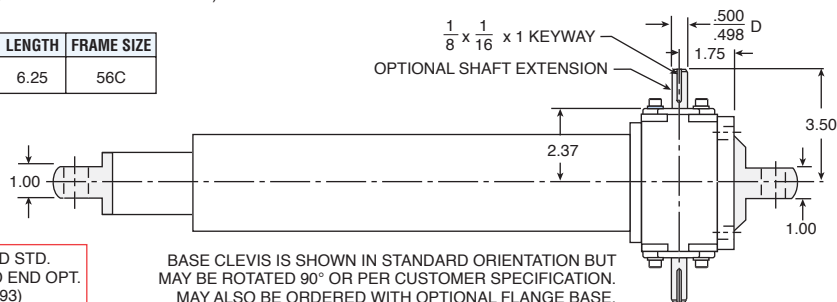

BASE CLEVIS IS SHOWN IN STANDARD ORIENTATION BUT  
MAY BE ROTATED 90° OR PER CUSTOMER SPECIFICATION.  
MAY ALSO BE ORDERED WITH OPTIONAL FLANGE BASE.

BOTTOM VIEW

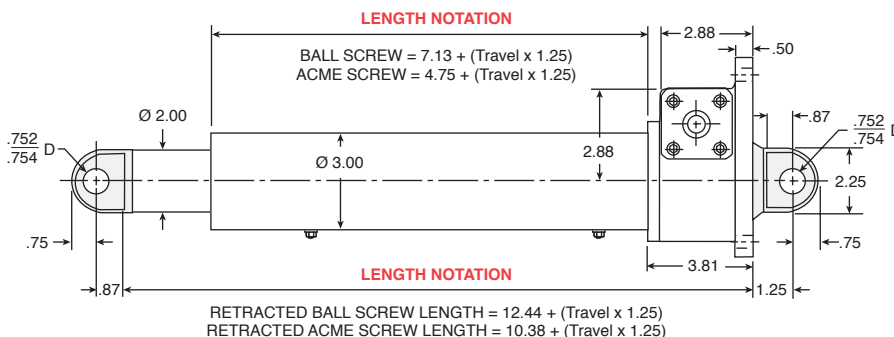
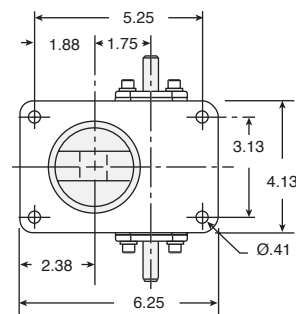

RETRACTED BALL SCREW LENGTH = 12.44 + (Travel x 1.25)  
RETRACTED ACME SCREW LENGTH = 10.38 + (Travel x 1.25)

## DD-25 BALL SCREW MODELS

MODEL NUMBER	TRAVEL RATE [in./min.]	DYNAMIC CAPACITY [lb.]	RATED LIFE [in. x 10 <sup>6</sup> ]	STD. MOTOR HP RATING [ref.]	STD. BRAKE TORQUE [ft.-lb.]	APPROX. STOPPING DISTANCE [in.]		MAXIMUM ROD REACTION TORQUE [in.-lb.]	BASIC WEIGHT [lbs.]
						No Load	Full Load		
DD-256-HL / 10XX	288	900	13.5	1	6	.26	.44	159	33
DD-256-HL / 20XX	288	1,800	1.69	2	10	.43	.74	318	33
DD-2512-HL / 10XX	144	1,500	2.91	1	6	.25	.35	265	33
DD-256-ML / 15XX	144	1,800	7	1.5	6	.25	.43	159	33
DD-256-ML / 20XX	144	3,600	.9	2	10	.21	.42	318	33
DD-256-HD / 10XX	72	3,600	.09	1	6	.12	.21	159	33
DD-256-HD / 07XX	72	2,000	4.1	.75	6	.06	.09	89	33
DD-2512-HD / 07XX	36	4,450	.38	.75	6	.03	.04	197	33
DD-2512-HD / 05XX	36	2,000	4.1	.5	3	.04	.06	89	33
DD-2524-HD / 05XX	18	4,450	.38	.5	3	.02	.03	197	33
DD-2524-HD / 03XX	18	1,500	9.9	.33	3	.02	.02	66	33

## DD-25 ACME SCREW MODELS

MODEL NUMBER	TRAVEL RATE [in./min.]	DYNAMIC CAPACITY [lb.]	STD. MOTOR HP RATING [ref.]	STD. BRAKE TORQUE [ft.-lb.]	APPROX. STOPPING DISTANCE [in.] NO LOAD	MAXIMUM ROD REACTION TORQUE [in.-lb.]	BASIC WEIGHT [lbs.]
DD-256-A2 / 15XX	144	1,725	1.5	6	.30	240	30
DD-256-A4 / 15XX	72	2,280	1.5	6	.15	239	30
DD-2512-A4 / 07XX	36	1,900	.75	6	.06	197	30
DD-2512-A4 / 10XX	36	2,500	1	6	.06	263	30
DD-2524-A4 / 05XX	18	1,880	.5	3	.02	197	30

Specifications on these charts are for standard units only and may change for modified non-standard units!

For Actuators without motors see page 376 for product specifications

**BALL SCREW MODELS:** TOTAL WEIGHT = (1.05)T + BASIC WEIGHT, where T = TRAVEL IN INCHES

**ACME SCREW MODELS:** TOTAL WEIGHT = (1.0)T + BASIC WEIGHT, where T = TRAVEL IN INCHES

**WARNING!** UNITS ARE NOT TO BE USED AS PERSONNEL SUPPORT OR MOVEMENT. BALL SCREW MODELS ARE SELF-LOWERING.

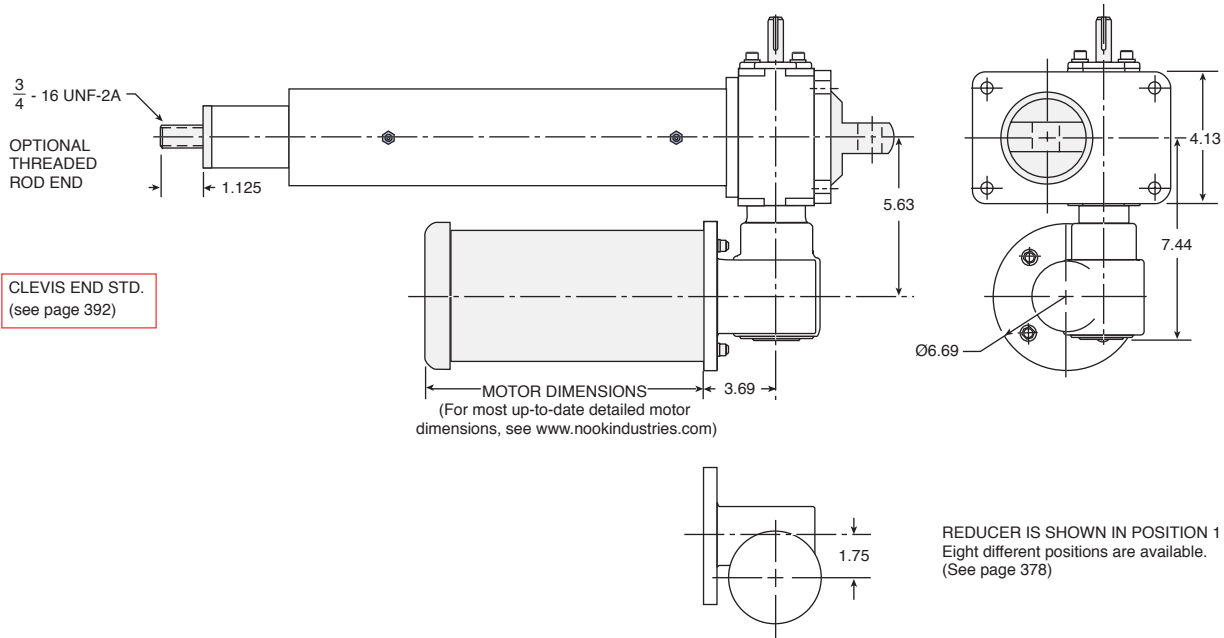

DD AND RAD ELECTRIC CYLINDERS

RAD-25 BALL SCREW MODELS									
MODEL NUMBER	TRAVEL RATE [in./min.]	DYNAMIC CAPACITY [lb.]	RATED LIFE [in. x 10 <sup>6</sup> ]	STD. MOTOR HP RATING [ref.]	STD. BRAKE TORQUE [ft.-lb.]	APPROX. STOPPING DISTANCE [in.]		MAXIMUM ROD REACTION TORQUE [in.-lb.]	BASIC WEIGHT [lbs.]
						No Load	Full Load		
RAD-2566-HL / 10XX	48	3,550	.22	1	6	.08	.08	628	46
RAD-2562-HL / 10XX	24	5,000	.08	1	6	.04	.04	885	46
RAD-2566-ML / 05XX	24	5,000	.33	.5	3	.014	.014	443	46
RAD-2562-HD / 03XX	6	5,000	.27	.33	3	.007	.007	221	46
RAD-2546-HD / 03XX	3	5,000	.27	.25	3	.003	.003	221	46

RAD-25 ACME SCREW MODELS							
MODEL NUMBER	TRAVEL RATE [in./min.]	DYNAMIC CAPACITY [lbf.]	STD. MOTOR HP RATING [ref.]	STD. BRAKE TORQUE [ft.-lb.]	APPROX. STOPPING DISTANCE [in.] NO LOAD	MAXIMUM ROD REACTION TORQUE [in.-lb.]	BASIC WEIGHT [lbs.]
RAD-2566-A4 / 07XX	12	5,000	.75	6	.02	525	44
RAD-2562-A4 / 05XX	6	5,000	.5	3	.005	525	44
RAD-2546-A4 / 03XX	3	5,000	.33	3	.004	525	44

## SERIES 25 DD & RAD

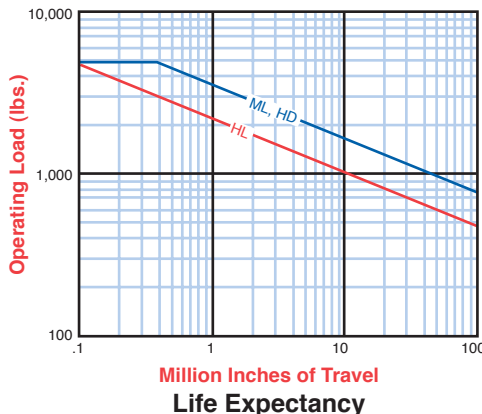
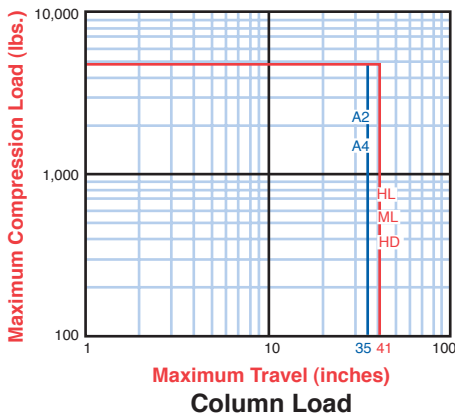

**ALL SCREW MODELS:**  
TOTAL WEIGHT = (1.05)T + BASIC WEIGHT, where T = TRAVEL IN INCHES

**ACME SCREW MODELS:**  
TOTAL WEIGHT = (1.0)T + BASIC WEIGHT, where T = TRAVEL IN INCHES

**WARNING!** UNITS ARE NOT TO BE USED AS PERSONNEL SUPPORT OR MOVEMENT. BALL SCREW MODELS ARE SELF-LOWERING.



MOTOR IS SHOWN IN POSITION 1  
Motor may be mounted to either side of cylinder (see page 376)

HP	DIA	FRAME SIZE
1/4-2	6.62	56C

MOTOR DIMENSIONS  
(For most up-to-date detailed motor dimensions, see www.nookindustries.com)

HP	LENGTH	FRAME SIZE
1/4-2	6.25	56C

TOP VIEW

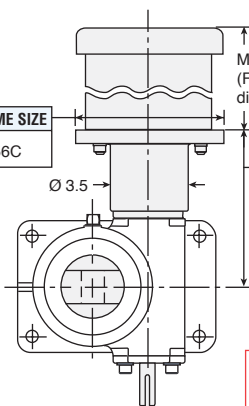

CLEVIS END STD. THREADED END OPT. (see page 395)

THE DIMENSIONS ON THESE VIEWS ARE COMMON TO BOTH DD & RAD MODELS

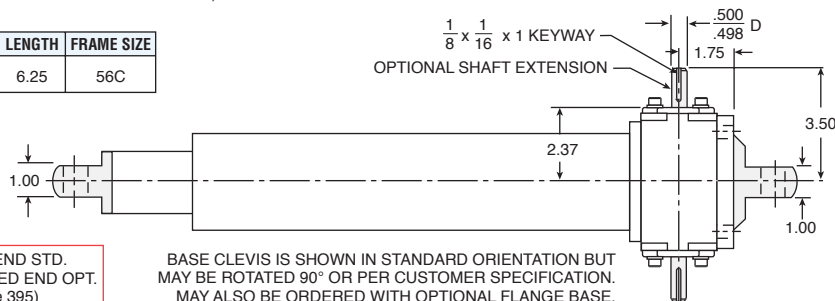

BASE CLEVIS IS SHOWN IN STANDARD ORIENTATION BUT MAY BE ROTATED 90° OR PER CUSTOMER SPECIFICATION. MAY ALSO BE ORDERED WITH OPTIONAL FLANGE BASE.

BOTTOM VIEW

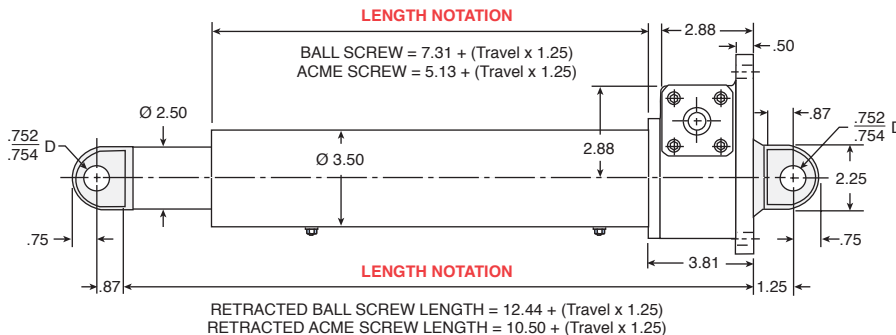
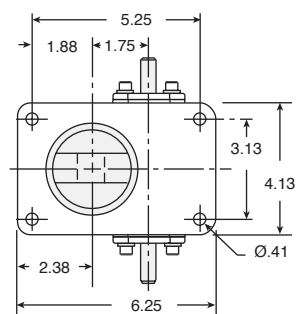

DD AND RAD ELECTRIC CYLINDERS

DD-30 BALL SCREW MODELS									
MODEL NUMBER	TRAVEL RATE [in./min.]	DYNAMIC CAPACITY [lb.]	RATED LIFE [in. x 10 <sup>6</sup> ]	STD. MOTOR HP RATING [ref.]	STD. BRAKE TORQUE [ft.-lb.]	APPROX. STOPPING DISTANCE [in.]		MAXIMUM ROD REACTION TORQUE [in.-lb.]	BASIC WEIGHT [lbs.]
						No Load	Full Load		
DD-306-HD / 15XX	120	3,275	1.68	1.5	6	.25	.83	239	38
DD-3012-HD / 10XX	60	3,600	1.26	1.0	6	.10	.16	263	38
DD-3012-HD / 07XX	60	2,500	3.78	.75	6	.05	.07	183	38
DD-3024-HD / 05XX	30	2,700	3.00	.5	3	.03	.05	197	38

DD-30 ACME SCREW MODELS							
MODEL NUMBER	TRAVEL RATE [in./min.]	DYNAMIC CAPACITY [lbf.]	STD. MOTOR HP RATING [ref.]	STD. BRAKE TORQUE [ft.-lb.]	APPROX. STOPPING DISTANCE [in.] NO LOAD	MAXIMUM ROD REACTION TORQUE [in.-lb.]	BASIC WEIGHT [lbs.]
DD-306-A4 / 15XX	72	2,100	1.5	6	.15	240	33
DD-3012-A4 / 10XX	36	2,200	1	6	.06	263	33
DD-3024-A4 / 05XX	18	1,200	.5	3	.02	140	33

Specifications on these charts are for standard units only and may change for modified non-standard units!  
For Actuators without motors see page 376 for product specifications

**BALL SCREW MODELS:** TOTAL WEIGHT = (1.31)T + BASIC WEIGHT, where T = TRAVEL IN INCHES  
**ACME SCREW MODELS:** TOTAL WEIGHT = (1.38)T + BASIC WEIGHT, where T = TRAVEL IN INCHES

**WARNING!** UNITS ARE NOT TO BE USED AS PERSONNEL SUPPORT OR MOVEMENT. BALL SCREW MODELS ARE SELF-LOWERING.

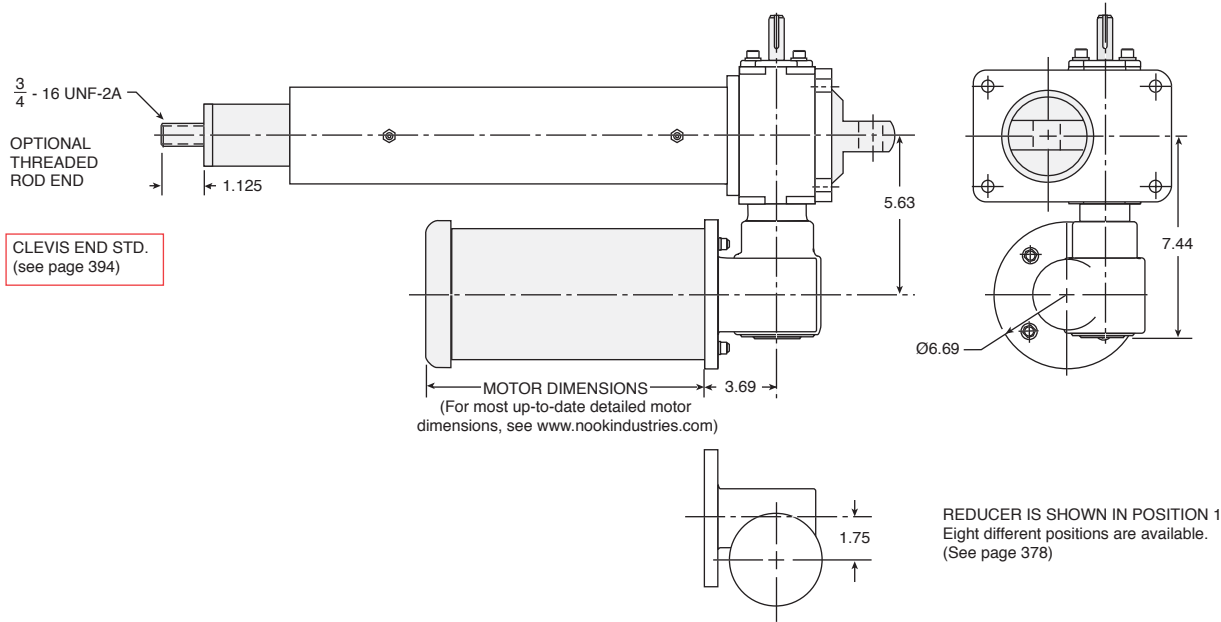

DD AND RAD ELECTRIC CYLINDERS

### RAD-30 BALL SCREW MODELS

MODEL NUMBER	TRAVEL RATE [in./min.]	DYNAMIC CAPACITY [lb.]	RATED LIFE [in. x 10 <sup>6</sup> ]	STD. MOTOR HP RATING [ref.]	STD. BRAKE TORQUE [ft.-lb.]	APPROX. STOPPING DISTANCE [in.]		MAXIMUM ROD REACTION TORQUE [in.-lb.]	BASIC WEIGHT [lbs.]
						No Load	Full Load		
RAD-3066-HD / 05XX	20	4,775	.54	.5	3	.02	.02	349	51
RAD-3062-HD / 03XX	10	5,250	.40	.33	3	.012	.012	383	51
RAD-3022-HD / 03XX	5	6,000	.27	.33	3	.006	.006	439	51

### RAD-30 ACME SCREW MODELS

MODEL NUMBER	TRAVEL RATE [in./min.]	DYNAMIC CAPACITY [lbf.]	STD. MOTOR HP RATING [ref.]	STD. BRAKE TORQUE [ft.-lb.]	APPROX. STOPPING DISTANCE [in.] NO LOAD	MAXIMUM ROD REACTION TORQUE [in.-lb.]	BASIC WEIGHT [lbs.]
RAD-3066-A4 / 10XX	12	6,000	1	6	.02	702	47
RAD-3062-A4 / 07XX	6	4,925	.75	3	.005	575	47
RAD-3022-A4 / 05XX	3	6,000	.5	3	.004	702	47

## SERIES 30 DD & RAD

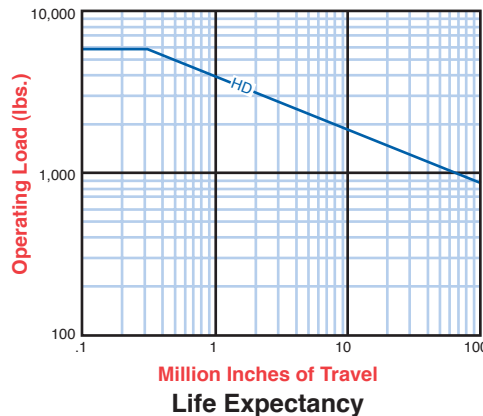
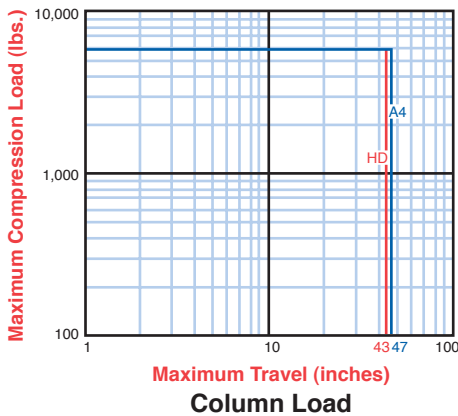

**BALL SCREW MODELS:**  
TOTAL WEIGHT = (1.31)T + BASIC WEIGHT, where T = TRAVEL IN INCHES

**ACME SCREW MODELS:**  
TOTAL WEIGHT = (1.38)T + BASIC WEIGHT, where T = TRAVEL IN INCHES

**WARNING!** UNITS ARE NOT TO BE USED AS PERSONNEL SUPPORT OR MOVEMENT. BALL SCREW MODELS ARE SELF-LOWERING.

MOTOR IS SHOWN  
IN POSITION 1  
Motor may be mounted  
to either side of cylinder  
(see page 376)

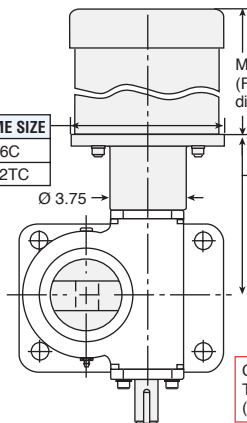

MOTOR DIMENSIONS  
(For most up-to-date detailed motor  
dimensions, see [www.nookindustries.com](http://www.nookindustries.com))

HP	DIA	FRAME SIZE
3/4-2	6.75	56C
3	9.25	182TC

HP	LENGTH	FRAME SIZE
3/4-2	7.25	56C
3	8.00	182TC

TOP VIEW

THE DIMENSIONS ON THESE VIEWS  
ARE COMMON TO BOTH DD & RAD MODELS

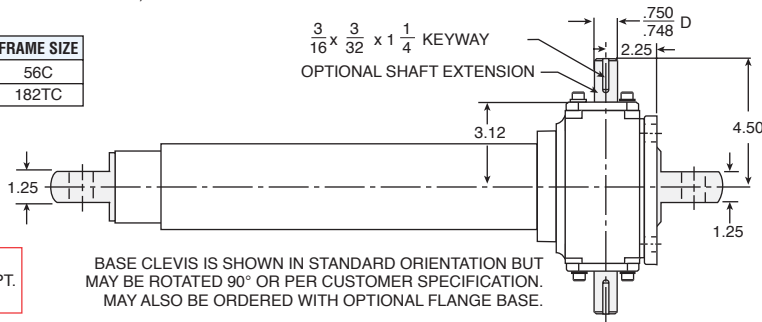

CLEVIS END STD.  
THREADED END OPT.  
(see page 397)

BASE CLEVIS IS SHOWN IN STANDARD ORIENTATION BUT  
MAY BE ROTATED 90° OR PER CUSTOMER SPECIFICATION.  
MAY ALSO BE ORDERED WITH OPTIONAL FLANGE BASE.

BOTTOM VIEW

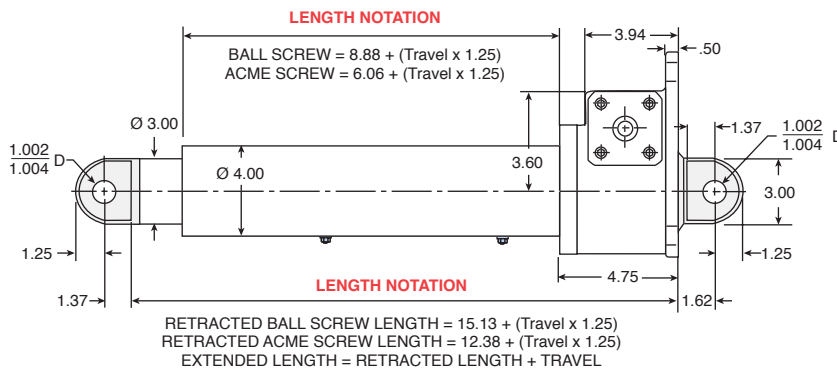
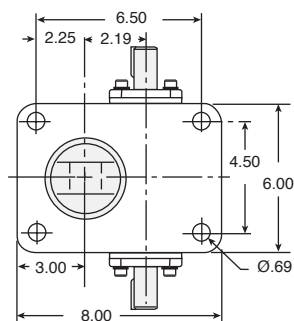

DD AND RAD ELECTRIC CYLINDERS

## DD-50 BALL SCREW MODELS

MODEL NUMBER	TRAVEL RATE [in./min.]	DYNAMIC CAPACITY [lb.]	RATED LIFE [in. x 10 <sup>6</sup> ]	STD. MOTOR HP RATING [ref.]	STD. BRAKE TORQUE [ft.-lb.]	APPROX. STOPPING DISTANCE [in.]		MAXIMUM ROD REACTION TORQUE [in.-lb.]	BASIC WEIGHT [lbs.]
						No Load	Full Load		
DD-506-SL / 20XX	539	950	110	2	10	.8	1.7	501	63
DD-506-HL / 20XX	288	2,000	73	2	10	.43	1.07	320	63
DD-506-HL / 30XX	288	2,500	21	3	15	.74	1.48	480	63
DD-506-HD / 20XX	136	4,000	18	2	10	.20	.46	320	63
DD-506-HD / 30XX	136	5,750	5.4	3	15	.35	.66	480	63
DD-5024-HD / 07XX	34	3,000	19	0.75	6	.03	.04	314	63

## DD-50 ACME SCREW MODELS

MODEL NUMBER	TRAVEL RATE [in./min.]	DYNAMIC CAPACITY [lb.]	STD. MOTOR HP RATING [ref.]	STD. BRAKE TORQUE [ft.-lb.]	APPROX. STOPPING DISTANCE [in.] NO LOAD	MAXIMUM ROD REACTION TORQUE [in.-lb.]	BASIC WEIGHT [lbs.]
DD-506-A3 / 10XX	108	1,000	1	6	.19	143	53
DD-506-A3 / 20XX	108	2,200	2	10	.16	288	53
DD-506-A3 / 30XX	108	2,900	3	15	.28	432	53
DD-508-A4 / 20XX	54	3,000	3	15	.08	455	53
DD-5024-A3 / 07XX	27	1,900	.75	6	.02	285	53

Specifications on these charts are for standard units only and may change for modified non-standard units!

For Actuators without motors see page 376 for product specifications

**BALL SCREW MODELS:** TOTAL WEIGHT = (1.92)T + BASIC WEIGHT, where T = TRAVEL IN INCHES

**ACME SCREW MODELS:** TOTAL WEIGHT = (1.87)T + BASIC WEIGHT, where T = TRAVEL IN INCHES

**WARNING!** UNITS ARE NOT TO BE USED AS PERSONNEL SUPPORT OR MOVEMENT. BALL SCREW MODELS ARE SELF-LOWERING.

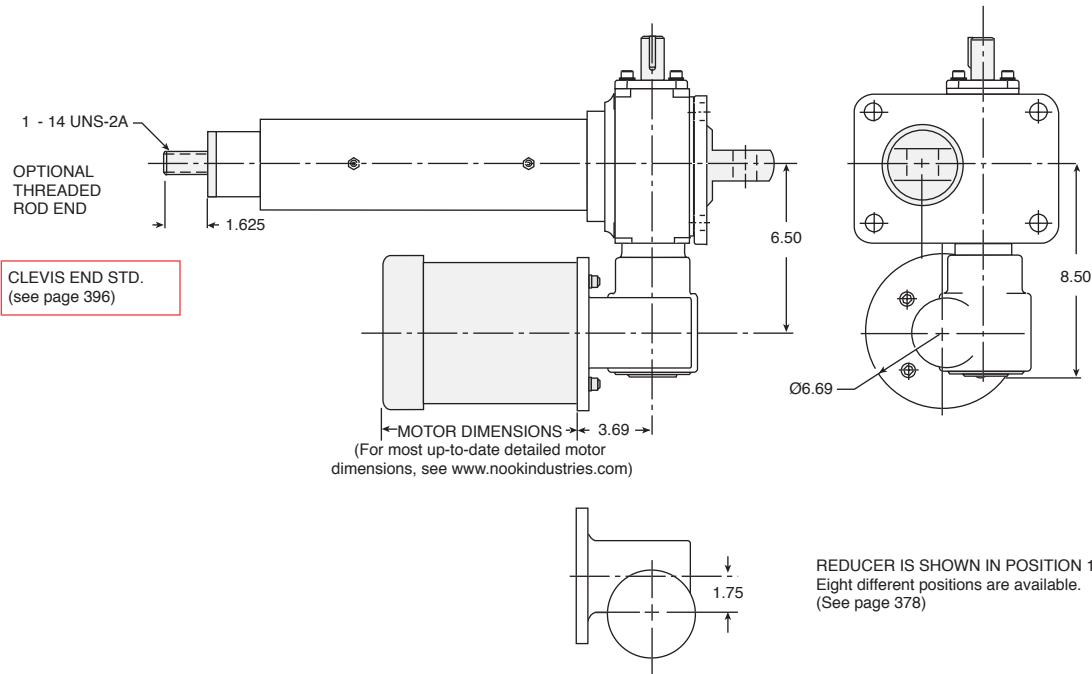

DD AND RAD ELECTRIC CYLINDERS

RAD-50 BALL SCREW MODELS									
MODEL NUMBER	TRAVEL RATE [in./min.]	DYNAMIC CAPACITY [lb.]	RATED LIFE [in. x 10 <sup>6</sup> ]	STD. MOTOR HP RATING [ref.]	STD. BRAKE TORQUE [ft.-lb.]	APPROX. STOPPING DISTANCE [in.]		MAXIMUM ROD REACTION TORQUE [in.-lb.]	BASIC WEIGHT [lbs.]
						No Load	Full Load		
RAD-5066-HL / 10XX	48	4,000	22	1	6	.08	.08	478	77
RAD-5066-HD / 10XX	23	5,000	5.6	1	6	.04	.04	475	77
RAD-5046-HL / 10XX	12	8,000	1.5	1	6	.02	.02	1,179	77
RAD-5062-HD / 10XX	11	9,000	1.4	1	6	.02	.02	754	77
RAD-5046-HD / 10XX	6	9,000	1.4	1	6	.02	.01	754	77

RAD-50 ACME SCREW MODELS								
MODEL NUMBER	TRAVEL RATE [in./min.]	DYNAMIC CAPACITY [lbf.]	STD. MOTOR HP RATING [ref.]	STD. BRAKE TORQUE [ft.-lb.]	APPROX. STOPPING DISTANCE [in.] NO LOAD	MAXIMUM ROD REACTION TORQUE [in.-lb.]	BASIC WEIGHT [lbs.]	
RAD-5066-A3 / 10XX	18	2,700	1	6	.03	402	66	
RAD-5062-A3 / 10XX	9	4,500	1	6	.02	670	66	
RAD-5046-A3 / 10XX	4.5	7,200	1	6	.01	1,073	66	

## SERIES 50 DD & RAD

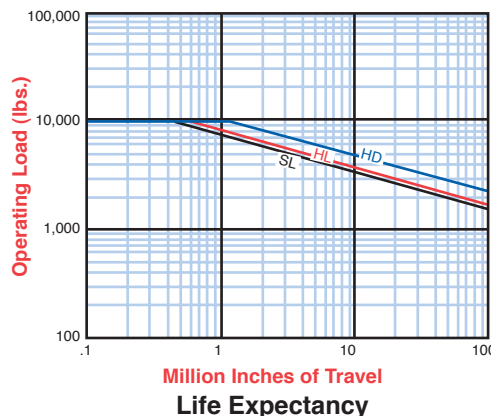
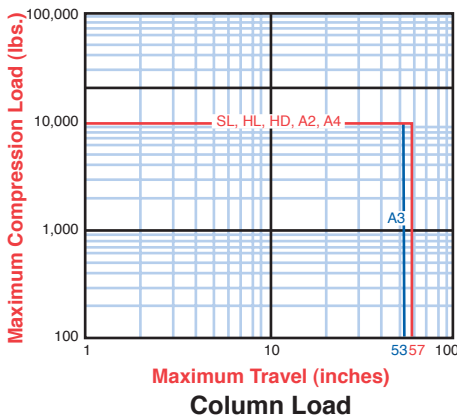

**BALL SCREW MODELS:**  
TOTAL WEIGHT = (1.92)T + BASIC WEIGHT, where T = TRAVEL IN INCHES

**ACME SCREW MODELS:**  
TOTAL WEIGHT = (1.87)T + BASIC WEIGHT, where T = TRAVEL IN INCHES

**WARNING!** UNITS ARE NOT TO BE USED AS PERSONNEL SUPPORT OR MOVEMENT. BALL SCREW MODELS ARE SELF-LOWERING.

MOTOR IS SHOWN  
IN POSITION 1  
Motor may be mounted  
to either side of cylinder  
(see page 376)

HP	DIA	FRAME SIZE
1-2	6.75	56C
3-5	9.25	184TC

MOTOR DIMENSIONS  
(For most up-to-date detailed motor  
dimensions, see www.nookindustries.com)

HP	LENGTH	FRAME SIZE
1-2	8.25	56C
3-5	9.00	184TC

TOP VIEW

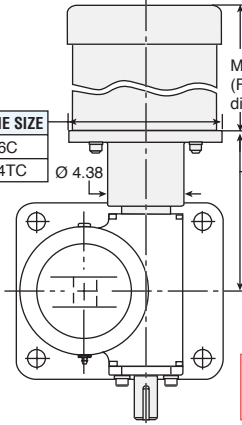

CLEVIS END STD.  
THREADED END OPT.  
(see page 399)

THE DIMENSIONS ON THESE VIEWS  
ARE COMMON TO BOTH DD & RAD MODELS

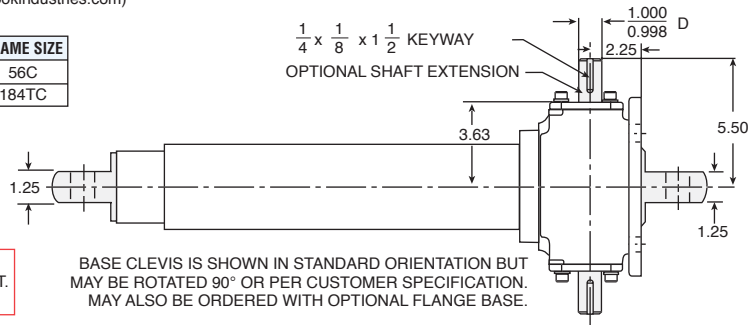

BASE CLEVIS IS SHOWN IN STANDARD ORIENTATION BUT  
MAY BE ROTATED 90° OR PER CUSTOMER SPECIFICATION.  
MAY ALSO BE ORDERED WITH OPTIONAL FLANGE BASE.

BOTTOM VIEW

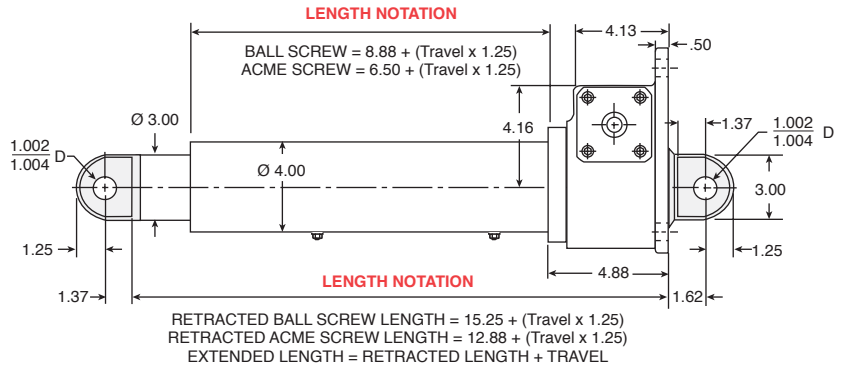
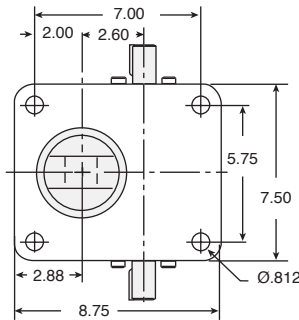

DD AND RAD ELECTRIC CYLINDERS

## DD-100 BALL SCREW MODELS

MODEL NUMBER	TRAVEL RATE [in./min.]	DYNAMIC CAPACITY [lb.]	RATED LIFE [in. x 10 <sup>6</sup> ]	STD. MOTOR HP RATING [ref.]	STD. BRAKE TORQUE [ft.-lb.]	APPROX. STOPPING DISTANCE [in.]		MAXIMUM ROD REACTION TORQUE [in.-lb.]	BASIC WEIGHT [lbs.]
						No Load	Full Load		
DD-1008-SL / 20XX	404	1,150	240	2	10	.6	.9	385	80
DD-1008-HL / 20XX	216	2,175	42	2	10	.3	.5	385	80
DD-1008-HL / 50XX	216	5,400	2.7	5	15	.7	1.3	956	80
DD-1008-HD / 20XX	102	4,600	10.4	2	10	.2	.2	385	80
DD-1008-HD / 30XX	102	7,500	2.4	3	15	.3	.4	628	80
DD-1008-HD / 50XX	102	12,000	.59	5	15	.3	.7	1005	80
DD-10024-HL / 15XX	72	2,700	22	1.5	6	.15	.16	478	80
DD-10024-HD / 15XX	34	7,150	2.8	1.5	6	.07	.09	598	80

## DD-100 ACME SCREW MODELS

MODEL NUMBER	TRAVEL RATE [in./min.]	DYNAMIC CAPACITY [lb.]	STD. MOTOR HP RATING [ref.]	STD. BRAKE TORQUE [ft.-lb.]	APPROX. STOPPING DISTANCE [in.] NO LOAD	MAXIMUM ROD REACTION TORQUE [in.-lb.]	BASIC WEIGHT [lbs.]
DD-1008-A2 / 20XX	108	2,000	2	10	.6	398	77
DD-1008-A2 / 30XX	108	3,000	3	15	.3	597	77
DD-1008-A2 / 50XX	108	4,500	5	15	.7	896	77
DD-1008-A4 / 20XX	54	2,000	2	10	.2	362	77
DD-10024-A2 / 15XX	36	2,000	1.5	6	.3	398	77

Specifications on these charts are for standard units only and may change for modified non-standard units!

For Actuators without motors see page 376 for product specifications

**BALL SCREW MODELS:** TOTAL WEIGHT = (1.92)T + BASIC WEIGHT, where T = TRAVEL IN INCHES

**ACME SCREW MODELS:** TOTAL WEIGHT = (2.5)T + BASIC WEIGHT, where T = TRAVEL IN INCHES

**WARNING!** UNITS ARE NOT TO BE USED AS PERSONNEL SUPPORT OR MOVEMENT. BALL SCREW MODELS ARE SELF-LOWERING.

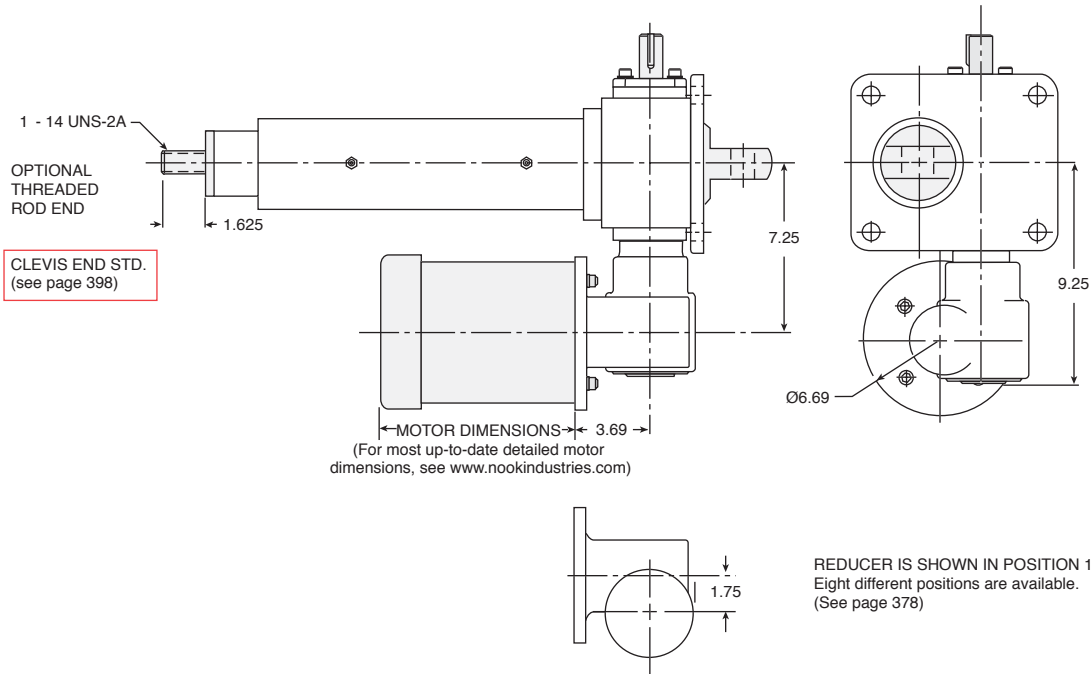

DD AND RAD ELECTRIC CYLINDERS

RAD-100 BALL SCREW MODELS									
MODEL NUMBER	TRAVEL RATE [in./min.]	DYNAMIC CAPACITY [lb.]	RATED LIFE [in. x 10 <sup>6</sup> ]	STD. MOTOR HP RATING [ref.]	STD. BRAKE TORQUE [ft.-lb.]	APPROX. STOPPING DISTANCE [in.]		MAXIMUM ROD REACTION TORQUE [in.-lb.]	BASIC WEIGHT [lbs.]
						No Load	Full Load		
RAD-10086-HL / 10XX	36	4,275	5.5	1	6	.06	.06	758	93
RAD-10086-HD / 10XX	17	10,000	1.0	1	6	.03	.03	837	93
RAD-10046-HL / 10XX	12	9,750	.47	1	6	.02	.02	1,226	93
RAD-10082-HD / 10XX	9	15,000	.3	1	6	.01	.01	1,258	93
RAD-10046-HD / 10XX	6	18,750	.15	1	6	.01	.01	1,571	93

RAD-100 ACME SCREW MODELS							
MODEL NUMBER	TRAVEL RATE [in./min.]	DYNAMIC CAPACITY [lbf.]	STD. MOTOR HP RATING [ref.]	STD. BRAKE TORQUE [ft.-lb.]	APPROX. STOPPING DISTANCE [in.] NO LOAD	MAXIMUM ROD REACTION TORQUE [in.-lb.]	BASIC WEIGHT [lbs.]
RAD-10086-A2 / 10XX	18	3,800	1	6	.06	756	89
RAD-10082-A2 / 10XX	9	6,275	1	6	.07	1,249	89
RAD-10046-A2 / 10XX	6	7,800	1	6	.03	1,552	89

## SERIES 100 DD & RAD

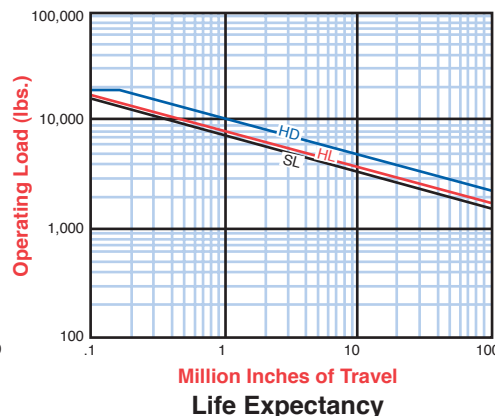
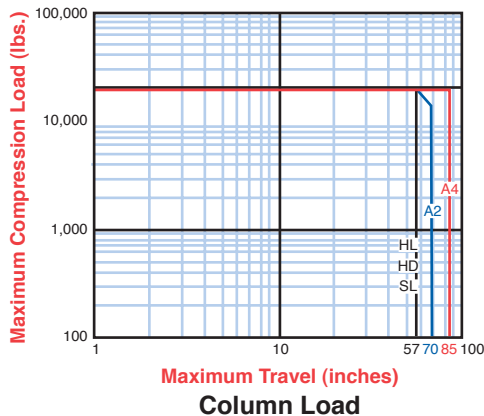

**BALL SCREW MODELS:**  
TOTAL WEIGHT = (1.92)T + BASIC WEIGHT, where T = TRAVEL IN INCHES

**ACME SCREW MODELS:**  
TOTAL WEIGHT = (2.5)T + BASIC WEIGHT, where T = TRAVEL IN INCHES

**WARNING!** UNITS ARE NOT TO BE USED AS PERSONNEL SUPPORT OR MOVEMENT. BALL SCREW MODELS ARE SELF-LOWERING.

MOTOR IS SHOWN IN POSITION 1  
Motor may be mounted to either side of cylinder (see page 376)

HP	DIA	FRAME SIZE
2	6.75	56C
3-5	9.25	184TC
7.5	9.25	213TC

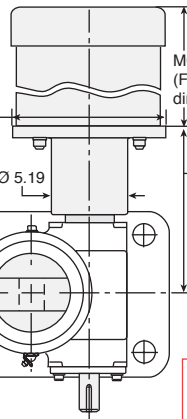

MOTOR DIMENSIONS  
(For most up-to-date detailed motor dimensions, see www.nookindustries.com)

HP	LENGTH	FRAME SIZE
2	8.65	56C
3-5	9.00	184TC
7.5	9.65	213TC

TOP VIEW

THE DIMENSIONS ON THESE VIEWS ARE COMMON TO BOTH DD & RAD MODELS

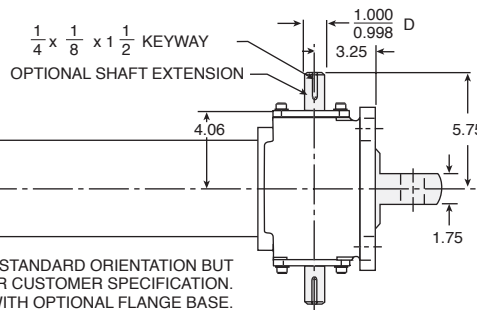

CLEVIS END STD.  
THREADED END OPT.  
(see page 401)

BASE CLEVIS IS SHOWN IN STANDARD ORIENTATION BUT MAY BE ROTATED 90° OR PER CUSTOMER SPECIFICATION. MAY ALSO BE ORDERED WITH OPTIONAL FLANGE BASE.

BOTTOM VIEW

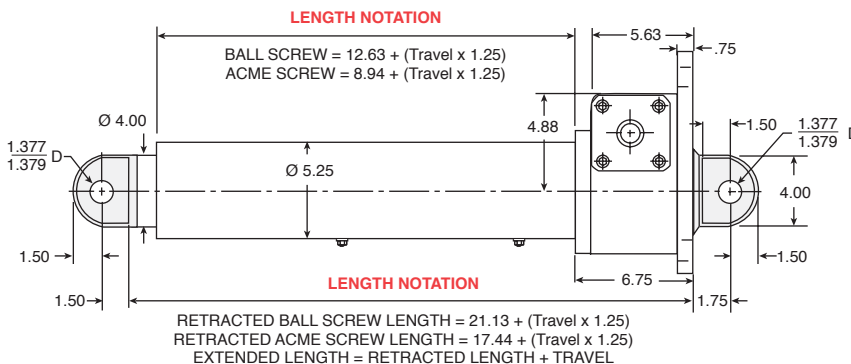
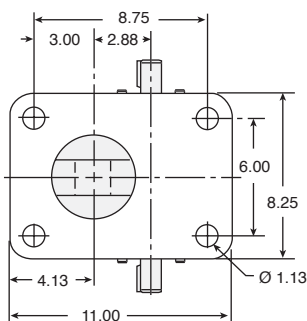

DD AND RAD ELECTRIC CYLINDERS

## DD-200 BALL SCREW MODELS

MODEL NUMBER	TRAVEL RATE [in./min.]	DYNAMIC CAPACITY [lb.]	RATED LIFE [in. x 10 <sup>6</sup> ]	STD. MOTOR HP RATING [ref.]	STD. BRAKE TORQUE [ft.-lb.]	APPROX. STOPPING DISTANCE [in.]		MAXIMUM ROD REACTION TORQUE [in.-lb.]	BASIC WEIGHT [lbs.]
						No Load	Full Load		
DD-2008-HL / 70XX	216	8,000	36	7.5	25	.4	.6	1,416	154
DD-2008-HD / 70XX	108	16,600	2.1	7.5	25	.2	.3	1,469	154
DD-2008-HD / 50XX	108	11,000	7.3	5	15	.4	.7	979	154
DD-20024-HL / 20XX	72	4,000	292	2	10	.1	.1	708	154
DD-20024-HD / 20XX	36	7,000	28	2	10	.1	.1	620	154
DD-20024-HD / 30XX	36	10,000	9.7	3	15	.1	.1	885	154

## DD-200 ACME SCREW MODELS

MODEL NUMBER	TRAVEL RATE [in./min.]	DYNAMIC CAPACITY [lb.]	STD. MOTOR HP RATING [ref.]	STD. BRAKE TORQUE [ft.-lb.]	APPROX. STOPPING DISTANCE [in.]	MAXIMUM ROD REACTION TORQUE [in.-lb.]	BASIC WEIGHT [lbs.]
					NO LOAD		
DD-2008-A2 / 70XX	108	4,250	7.5	15	.4	995	138
DD-2008-A3 / 70XX	72	4,620	7.5	15	.24	979	138
DD-20024-A2 / 20XX	36	2,500	2	10	.05	585	138
DD-20024-A2 / 30XX	36	3,500	3	15	.09	819	138

Specifications on these charts are for standard units only and may change for modified non-standard units!

For Actuators without motors see page 376 for product specifications

**BALL SCREW MODELS:** TOTAL WEIGHT = (3.31)T + BASIC WEIGHT, where T = TRAVEL IN INCHES

**ACME SCREW MODELS:** TOTAL WEIGHT = (3.6)T + BASIC WEIGHT, where T = TRAVEL IN INCHES

**WARNING!** UNITS ARE NOT TO BE USED AS PERSONNEL SUPPORT OR MOVEMENT. BALL SCREW MODELS ARE SELF-LOWERING.

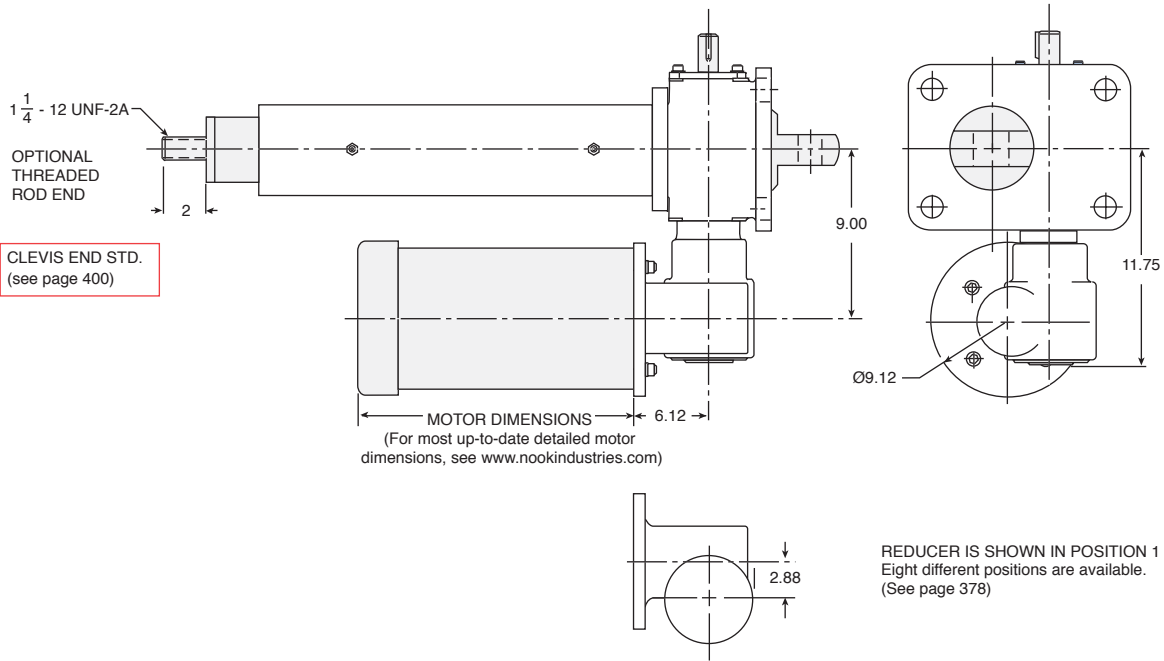

RAD-200 BALL SCREW MODELS									
MODEL NUMBER	TRAVEL RATE [in./min.]	DYNAMIC CAPACITY [lb.]	RATED LIFE [in. x 10 <sup>6</sup> ]	STD. MOTOR HP RATING [ref.]	STD. BRAKE TORQUE [ft.-lb.]	APPROX. STOPPING DISTANCE [in.]		MAXIMUM ROD REACTION TORQUE [in.-lb.]	BASIC WEIGHT [lbs.]
						No Load	Full Load		
RAD-20088-HL / 50XX	27	30,000	.69	5	15	.09	.09	5,300	202
RAD-20088-HD / 30XX	13.5	35,000	.23	3	15	.03	.03	3,098	202
RAD-20048-HL / 30XX	9	35,000	.44	3	15	.02	.02	6,195	202
RAD-20048-HD / 20XX	4.5	40,000	.15	2	10	.01	.01	3,540	202

RAD-200 ACME SCREW MODELS								
MODEL NUMBER	TRAVEL RATE [in./min.]	DYNAMIC CAPACITY [lbf.]	STD. MOTOR HP RATING [ref.]	STD. BRAKE TORQUE [ft.-lb.]	APPROX. STOPPING DISTANCE [in.] NO LOAD	MAXIMUM ROD REACTION TORQUE [in.-lb.]	BASIC WEIGHT [lbs.]	
RAD-20088-A2 / 70XX	13.5	31,000	7.5	25	.03	7,254	187	
RAD-20088-A3 / 50XX	9	22,500	5	15	.03	4,770	187	
RAD-20048-A2 / 30XX	4.5	12,500	3	15	.01	2,925	187	

## SERIES 200 DD & RAD

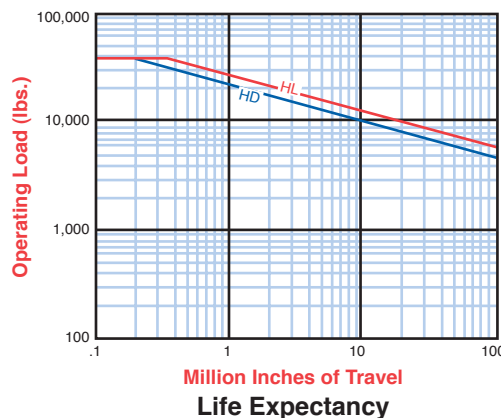
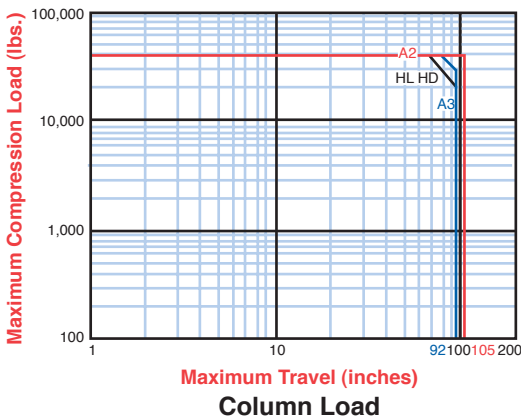

**BALL SCREW MODELS:**  
TOTAL WEIGHT =  
(3.31)T + BASIC WEIGHT,  
where T = TRAVEL IN INCHES

**ACME SCREW MODELS:**  
TOTAL WEIGHT =  
(3.6)T + BASIC WEIGHT,  
where T = TRAVEL IN INCHES

**WARNING!** UNITS ARE NOT TO  
BE USED AS PERSONNEL  
SUPPORT OR MOVEMENT.  
BALL SCREW MODELS ARE  
SELF-LOWERING.