

CC™ Linear Actuators

HIGH PERFORMANCE, LOW COST, POSITIONING SYSTEM 3000 LB. STATIC CAPACITY



CC Linear Actuators are ball screw linear actuators that provide a high performance and accurate positioning solution. These high-quality actuators feature:

- Durable construction
- Dependable performance
- Long-life operation
- High repeatability
- Operation in either compression or tension loading applications
- Adjustable limit switches
- Lifetime lubrication
- Mechanical overload protection
- Corrosion resistant exterior surfaces

COMMON APPLICATIONS

- Telecommunications
- Architectural Automation
- Medical and Hospital Equipment
- Semiconductor
- Food Processing
- Farm Equipment
- Satellite Dish and Antenna Positioning

STANDARD TRAVELS

4", 12", 18", 24" or 36"

DUTY CYCLE

30%, max "on-time" of 5 minutes at rated load

TEMPERATURE RATING

Operating temperature range is -30° F to +160° F

ENVIRONMENTAL PROTECTION CLASS

- IP64



The specifications and data in this publication are believed to be accurate and reliable. However, it is the responsibility of the product user to determine the suitability of Nook Industries products for a specific application. While defective products will be replaced without charge if promptly returned, no liability is assumed beyond such replacement.

FEATURES

CLUTCH

The CC Linear Actuator gear head offers a heavy-duty clutch that protects the gears and components in the event of overload or overtravel.



BRAKE

The load sensitive brake maintains the actuator's position when at rest, without consuming power.



BOOT

An optional boot keeps the actuator tube free of contaminants.

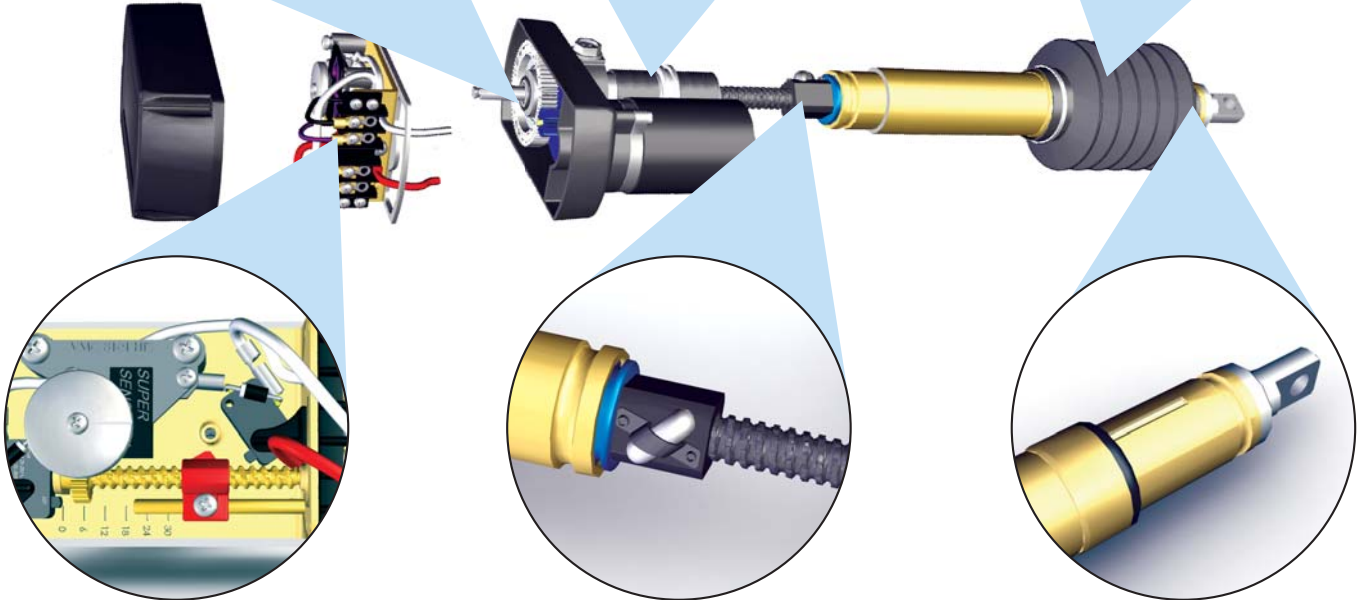
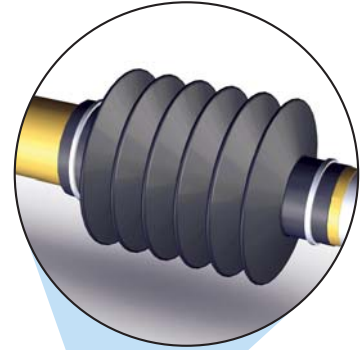

LIMIT SWITCH

The screw type limit switch offers precise positioning for travels up to 36 inches. The design of this switch allows the user to easily set limits at both ends of travel.

PRECISION LIMIT SWITCH

An optional precision limit switch is available for travels less than 24 inches. This limit switch offers higher resolution adjustment at setup. Contact Nook Engineering for ordering details.

BALL SCREW

CC Linear Actuators feature precision ball screws for greater efficiency.

SENSOR OPTIONS

A variety of sensor options for stroke control may be selected to fit specific applications. See page 413 for all sensor details.

KEYED

CC Linear Actuators may be ordered with a feature that allows the actuator tube to extend (retract) without being connected to the load. The key also reduces torque in clevises. Contact Nook Engineering for ordering details.

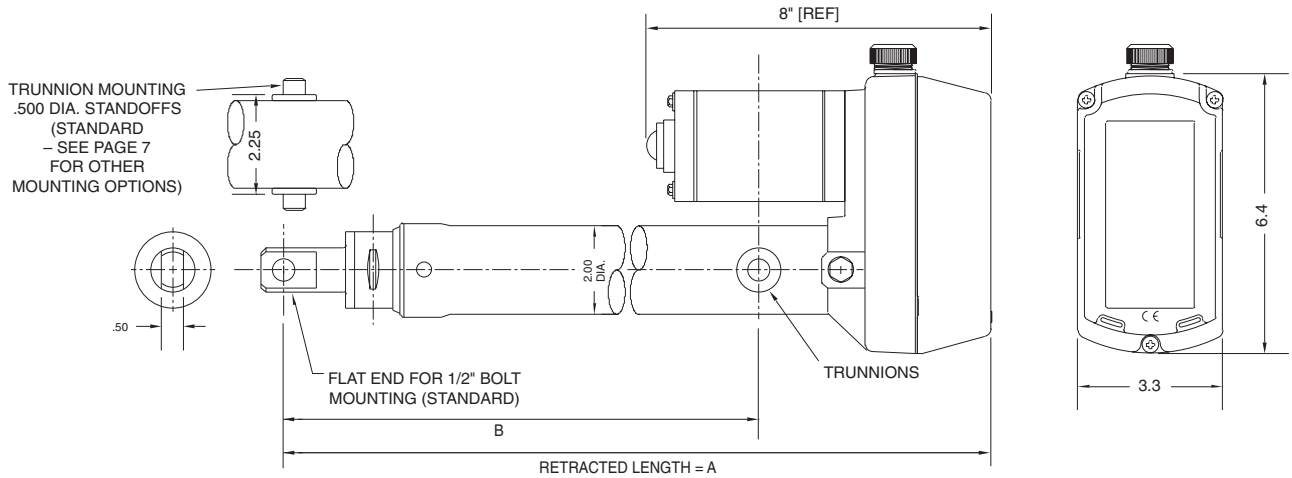

12 VDC														
STANDARD UNIT MODEL NUMBER	POTENTIOMETER POSITION SENSOR MODEL NUMBER	HALL EFFECT POSITION SENSOR MODEL NUMBER	LIMIT SWITCH MODEL NUMBER	STROKE		DIMENSIONS				DYNAMIC LOAD		AMP DRAW	TRAVEL RATE	
				(IN)	(MM)	A (IN)	A (MM)	B (IN)	B (MM)	LB	N		IN/SEC	MM/SEC
CCHD-3605	CCHD-1401	CCHD-1335	CCHD-2837	4	102	16.2	412	8.8	224	750	3330	22	1.1	28
CCHD-1187	CCHD-1402	CCHD-1336	CCHD-2838	8	203	20.2	513	12.8	326					
CCHD-3552	CCHD-1403	CCHD-1337	CCHD-2839	12	305	24.2	615	16.8	427					
CCHD-1058	CCHD-1404	CCHD-1338	CCHD-2840	18	457	32.2	818	24.8	631					
CCHD-1188	CCHD-1405	CCHD-1339	CCHD-2841	24	610	38.2	970	30.8	783					
CCHD-1189	CCHD-1406	CCHD-1340	CCHD-2842	36	914	50.2	1275	42.8	1088					
CCHD-4114	CCHD-1407	CCHD-1345	CCHD-2843	4	102	16.2	412	8.8	224	1500	6670	15	0.4	10
CCHD-1190	CCHD-1408	CCHD-1346	CCHD-2844	8	203	20.2	513	12.8	326					
CCHD-4273	CCHD-1409	CCHD-1347	CCHD-2845	12	305	24.2	615	16.8	427					
CCHD-1059	CCHD-1410	CCHD-1348	CCHD-2846	18	457	32.2	818	24.8	631					
CCHD-1191	CCHD-1411	CCHD-1349	CCHD-2847	24	610	38.2	970	30.8	783					
CCHD-1192	CCHD-1412	CCHD-1350	CCHD-2848	36	914	50.2	1275	42.8	1088					

24 VDC														
STANDARD UNIT MODEL NUMBER	POTENTIOMETER POSITION SENSOR MODEL NUMBER	HALL EFFECT POSITION SENSOR MODEL NUMBER	LIMIT SWITCH MODEL NUMBER	STROKE		DIMENSIONS				DYNAMIC LOAD		AMP DRAW	TRAVEL RATE	
				(IN)	(MM)	A (IN)	A (MM)	B (IN)	B (MM)	LB	N		IN/SEC	MM/SEC
CCHD-8532	CCHD-8544	CCHD-8556	CCHD-8568	4	102	16.2	412	8.8	224	750	3330	11	1.1	28
CCHD-8533	CCHD-8545	CCHD-8557	CCHD-8569	8	203	20.2	513	12.8	326					
CCHD-8534	CCHD-8546	CCHD-8558	CCHD-8570	12	305	24.2	615	16.8	427					
CCHD-8535	CCHD-8547	CCHD-8559	CCHD-8571	18	457	32.2	818	24.8	631					
CCHD-8536	CCHD-8548	CCHD-8560	CCHD-8572	24	610	38.2	970	30.8	783					
CCHD-8537	CCHD-8549	CCHD-8561	CCHD-8573	36	914	50.2	1275	42.8	1088					
CCHD-8538	CCHD-8550	CCHD-8562	CCHD-8574	4	102	16.2	412	8.8	224	1500	6670	8	0.4	10
CCHD-8539	CCHD-8551	CCHD-8563	CCHD-8575	8	203	20.2	513	12.8	326					
CCHD-8540	CCHD-8552	CCHD-8564	CCHD-8576	12	305	24.2	615	16.8	427					
CCHD-8541	CCHD-8553	CCHD-8565	CCHD-8577	18	457	32.2	818	24.8	631					
CCHD-8542	CCHD-8554	CCHD-8566	CCHD-8578	24	610	38.2	970	30.8	783					
CCHD-8543	CCHD-8555	CCHD-8567	CCHD-8579	36	914	50.2	1275	42.8	1088					

36 VDC														
STANDARD UNIT MODEL NUMBER	POTENTIOMETER POSITION SENSOR MODEL NUMBER	HALL EFFECT POSITION SENSOR MODEL NUMBER	LIMIT SWITCH MODEL NUMBER	STROKE		DIMENSIONS				DYNAMIC LOAD		AMP DRAW	TRAVEL RATE	
				(IN)	(MM)	A (IN)	A (MM)	B (IN)	B (MM)	LB	N		IN/SEC	MM/SEC
CCHD-1213	CCHD-1413	CCHD-1355	CCHD-2849	4	102	16.2	412	8.8	224	750	3330	8	1.1	28
CCHD-1214	CCHD-1414	CCHD-1356	CCHD-2850	8	203	20.2	513	12.8	326					
CCHD-1215	CCHD-1415	CCHD-1357	CCHD-2851	12	305	24.2	615	16.8	427					
CCHD-1216	CCHD-1416	CCHD-1358	CCHD-2852	18	457	32.2	818	24.8	631					
CCHD-1217	CCHD-1417	CCHD-1359	CCHD-2853	24	610	38.2	970	30.8	783					
CCHD-1218	CCHD-1418	CCHD-1360	CCHD-2854	36	914	50.2	1275	42.8	1088					
CCHD-1219	CCHD-1419	CCHD-1361	CCHD-2855	4	102	16.2	412	8.8	224	1500	6670	6	0.4	10
CCHD-1220	CCHD-1420	CCHD-1362	CCHD-2856	8	203	20.2	513	12.8	326					
CCHD-1221	CCHD-1421	CCHD-1363	CCHD-2857	12	305	24.2	615	16.8	427					
CCHD-1222	CCHD-1422	CCHD-1302	CCHD-2858	18	457	32.2	818	24.8	631					
CCHD-1223	CCHD-1423	CCHD-1328	CCHD-2859	24	610	38.2	970	30.8	783					
CCHD-1224	CCHD-1424	CCHD-1364	CCHD-2860	36	914	50.2	1275	42.8	1088					

90 VDC														
STANDARD UNIT MODEL NUMBER	POTENTIOMETER POSITION SENSOR MODEL NUMBER	HALL EFFECT POSITION SENSOR MODEL NUMBER	LIMIT SWITCH MODEL NUMBER	STROKE		DIMENSIONS				DYNAMIC LOAD		AMP DRAW	TRAVEL RATE	
				(IN)	(MM)	A (IN)	A (MM)	B (IN)	B (MM)	LB	N		IN/SEC	MM/SEC
CCHD-0254	CCHD-1425	CCHD-1365	CCHD-2861	4	102	16.2	412	8.8	224	750	3330	1.5	.6	15
CCHD-1241	CCHD-1426	CCHD-1366	CCHD-2862	8	203	20.2	513	12.8	326					
CCHD-0256	CCHD-1427	CCHD-1367	CCHD-2863	12	305	24.2	615	16.8	427					
CCHD-1064	CCHD-1428	CCHD-1368	CCHD-2864	18	457	32.2	818	24.8	631					
CCHD-1242	CCHD-1429	CCHD-1369	CCHD-2865	24	610	38.2	970	30.8	783					
CCHD-1243	CCHD-1430	CCHD-1370	CCHD-2866	36	914	50.2	1275	42.8	1088					
CCHD-0258	CCHD-1431	CCHD-1371	CCHD-2867	4	102	16.2	412	8.8	224	1500	6670	1	.2	5
CCHD-1244	CCHD-1432	CCHD-1372	CCHD-2868	8	203	20.2	513	12.8	326					
CCHD-0260	CCHD-1433	CCHD-1373	CCHD-2869	12	305	24.2	615	16.8	427					
CCHD-1065	CCHD-1143	CCHD-1374	CCHD-2870	18	457	32.2	818	24.8	631					
CCHD-1245	CCHD-1434	CCHD-1375	CCHD-2871	24	610	38.2	970	30.8	783					
CCHD-1246	CCHD-1435	CCHD-1376	CCHD-2872	36	914	50.2	1275	42.8	1088					

110 VAC (SUPPLIED WITH RECTIFIER AND VDC MOTOR)														
STANDARD UNIT MODEL NUMBER	POTENTIOMETER POSITION SENSOR MODEL NUMBER	HALL EFFECT POSITION SENSOR MODEL NUMBER	LIMIT SWITCH MODEL NUMBER	STROKE		DIMENSIONS				DYNAMIC LOAD		AMP DRAW	TRAVEL RATE	
				(IN)	(MM)	A (IN)	A (MM)	B (IN)	B (MM)	LB	N		IN/SEC	MM/SEC
CCHD-5368	CCHD-5433	CCHD-5409	CCHD-5445	4	102	16.2	412	8.8	224	750	3330	1.5	.6	15
CCHD-5391	CCHD-5434	CCHD-5410	CCHD-5446	8	203	20.2	513	12.8	326					
CCHD-5367	CCHD-5435	CCHD-5411	CCHD-5447	12	305	24.2	615	16.8	427					
CCHD-5382	CCHD-5436	CCHD-5412	CCHD-5448	18	457	32.2	818	24.8	631					
CCHD-5392	CCHD-5437	CCHD-5413	CCHD-5449	24	610	38.2	970	30.8	783					
CCHD-5393	CCHD-5438	CCHD-5414	CCHD-5450	36	914	50.2	1275	42.8	1088					
CCHD-5375	CCHD-5439	CCHD-5415	CCHD-5451	4	102	16.2	412	8.8	224	1500	6670	1	.2	5
CCHD-5394	CCHD-5440	CCHD-5416	CCHD-5452	8	203	20.2	513	12.8	326					
CCHD-5376	CCHD-5441	CCHD-5417	CCHD-5453	12	305	24.2	615	16.8	427					
CCHD-5384	CCHD-5442	CCHD-5418	CCHD-5454	18	457	32.2	818	24.8	631					
CCHD-5395	CCHD-5443	CCHD-5419	CCHD-5455	24	610	38.2	970	30.8	783					
CCHD-5396	CCHD-5444	CCHD-5420	CCHD-5456	36	914	50.2	1275	42.8	1088					

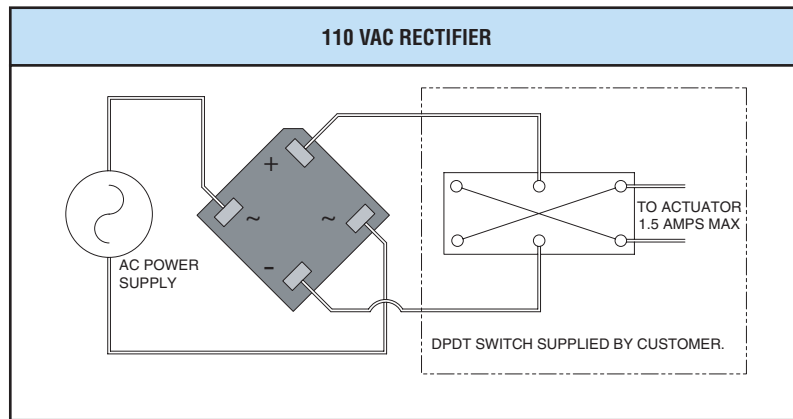
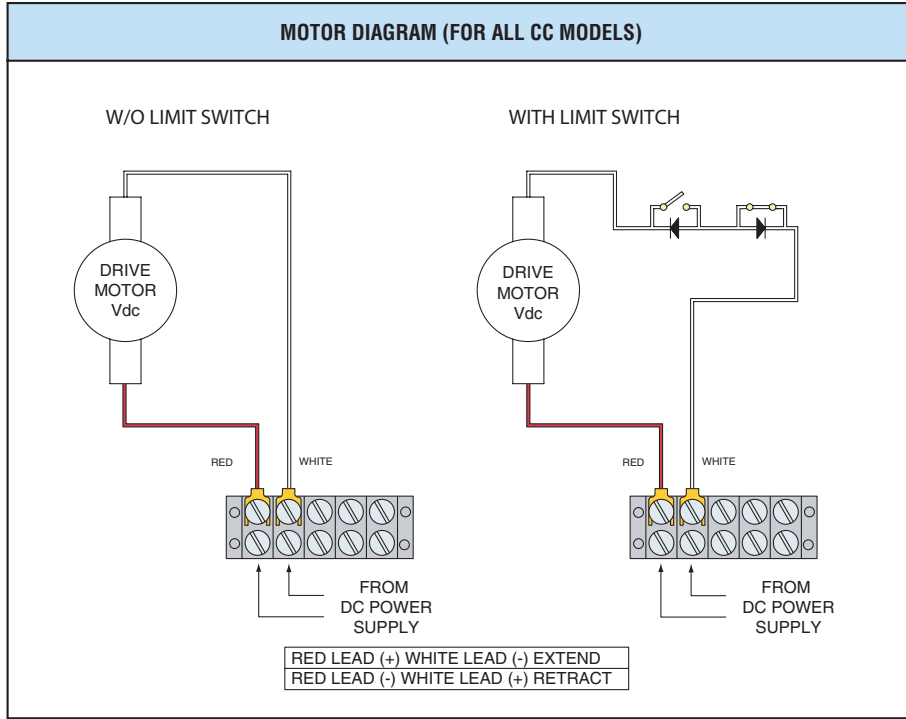

When 110 VAC input voltage is required, a DC motor is supplied with a rectifier.

SENSOR OPTIONS

Nook sensor options are used to provide input to counters, PLCs, or other control systems.

POTENTIOMETER

The 10Kohm potentiometer provides a varying resistance in proportion to the travel. Potentiometers offer absolute position feedback regardless of the loss of power.

HALL EFFECT

The hall effect sensor provides pulses at the rate of 40 per inch of travel.

REED SWITCH (OPTIONAL)

The reed switch provides contact closures at the rate of 40 per inch of travel. Contact Nook Engineering for ordering details.

POTENTIOMETER RESISTANCE WITH RETRACTION:
BROWN TO GREEN - MINIMUM
BROWN TO WHITE - MAXIMUM

10K POTENTIOMETER

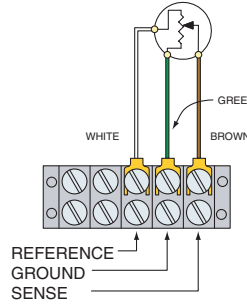

REED SWITCH

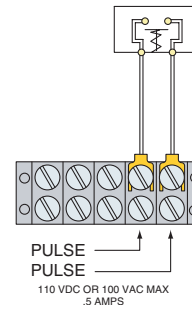

HALL EFFECT

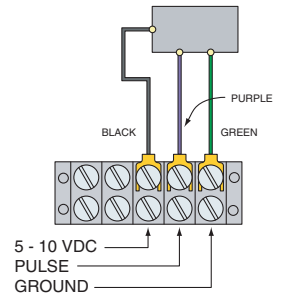

MOUNTING OPTIONS

CC Linear Actuators can be mounted with standard trunnions and clevis end. When double clevis mounting is required, an optional bracket is available.

3/4 SWIVEL BALL ENDS

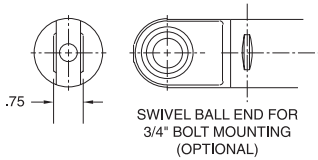

1/2 BOLT TUBE MOUNTING BRACKET

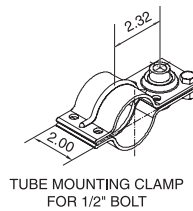

3/4 BOLT HEAVY-DUTY TUBE MOUNTING BRACKET

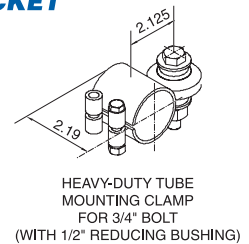

1/2 SWIVEL BALL ENDS

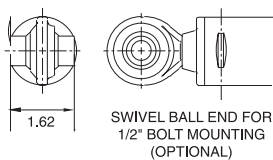

INLINE BRACKET

