



**WORM GEAR SCREW JACKS
TECHNICAL INTRODUCTION**

264-273

- Glossary and Technical Data 264-271
- Application Example 272
- Required Application Data Form 273

ACCESSORIES

274-290

- In-Line Encoder 274
- Motor and Motor Mounts 275
- Motor Reference and Brakemotor Wiring 276
- Right Angle Reducers 278-279
- Bellows Boots 280-281
- Rotary Limit Switch 282-283
- Flexible Couplings 284
- ActionJac™ LinkJac™ 285
- Miter Gear Assemblies 286
- Hand Wheels 287
- Counters 288
- Trunnion Adapters 289
- Servo Jacks 290

INCH BALL SCREW JACKS

291-311

- Quick Reference Chart 292-293
- Column Strength and Life Expectancy Charts 294-295
- Reference Number System: Inch Ball Screw Jacks 296
- Inch Ball Screw Jacks: 1/2 Ton to 100 Ton 297-311

INCH MACHINE SCREW JACKS

312-332

- Quick Reference Chart 314-315
- Column Strength Chart 316
- Reference Number System: Inch Machine Screw Jacks 317
- Inch Numeric Ratio Jacks: 1/2 Ton to 20 Ton 318
- Inch Machine Screw Jacks: 1/2 Ton to 100 Ton 319-332

**INCH STAINLESS STEEL
MACHINE SCREW JACKS**

333-343

- Quick Reference Chart 334
- Column Strength 335
- Reference Number System: Inch Stainless Steel Machine Screw 336
- Inch Machine Screw Jacks: 2 Ton to 35 Ton 337-343

METRIC BALL SCREW JACKS

344-354

- Quick Reference Chart 345
- Column Strength and Life Expectancy Charts 346-347
- Reference Number System: Metric Ball Screw Jacks 348

**METRIC BALL SCREW JACKS:
EM05 to EM20**

349-354

**METRIC TRAPEZOIDAL
SCREW JACKS**

355-364

- Quick Reference Chart 356
- Column Strength Chart 357
- Reference Number System: Metric Trapezoidal Screw Jacks 358
- Metric Trapezoidal Screw Jacks: EM05 to EM20 359-364



The specifications and data in this publication are believed to be accurate and reliable. However, it is the responsibility of the product user to determine the suitability of Nook Industries products for a specific application. While defective products will be replaced without charge if promptly returned, no liability is assumed beyond such replacement.

**ActionJac™
Worm Gear Screw Jacks**



ACTIONJAC™ JACKS

ActionJac™ Worm Gear Screw Jack systems are ruggedly designed and produced in standard models with load handling capacities from 1/4 ton to 100 tons.

They may be used individually or in multiple arrangements. There are no “standard” travel lengths and each Worm Gear Screw Jack is built to specification.

MACHINE SCREW JACKS

The worm gear driven Machine Screw Jack incorporates an alloy steel worm which drives a high strength bronze worm gear (drive sleeve). The worm shaft is supported on anti-friction tapered roller bearings with external seals provided to prevent loss of lubrication (sealed radial bearings on the 1/2 and 1 ton units). The drive sleeve is supported on anti-friction tapered roller or ball thrust bearings. Rotation of the drive sleeve causes the acme thread lifting screw to translate or rotate, depending upon jack configuration.

The jack housing is made of ductile iron (MJ models have aluminum housings, aluminum optional on one ton models) and proportioned to support the rated capacity of the unit. The lifting screw is made of alloy steel with a minimum tensile strength of 95,000 psi. The threads are precision formed, typically

using Class 2-C (Centralizing) tolerances. Jack lift shaft lead tolerance is approximately 0.004" per foot.

BALL SCREW JACKS

The ActionJac™ Ball Screw Jacks use the same worm gear set arrangement as machine screw jacks. The addition of a high efficiency ball screw and nut reduces the required input torque to approximately one-third the torque required for the Machine Screw Jack.

The Ball Screw Jack housing is made of ductile iron (1/2 BSJ and 1/2 HL-BSJ jacks have aluminum housings, aluminum optional on one ton models) and designed to support the rated capacity of the unit. The ball screw and nut are made from hardened alloy steel with hardened bearing balls carrying the load between nut and screw. This rolling action reduces friction between the nut and the screw permitting smooth and efficient movement of the load. Because of the greater efficiency and rolling action, the ball screw can operate at higher speeds or increased duty cycle when compared with the Machine Screw Jack. When a Ball Screw Jack is motorized, less horsepower is required than an equivalent size Machine Screw Jack.

STAINLESS STEEL SCREW JACKS

ActionJac™ Stainless Steel Machine Screw Jacks are ideal for use in demanding environments where corrosion resistance is required. All external components are manufactured from 300 Series Stainless Steel materials. These jacks use a stainless steel worm with a high strength bronze drive sleeve. The worm and drive sleeve are supported by tapered roller bearings and sealed to prevent loss of lubrication and to resist

contamination. The stainless steel lifting screw threads are precision formed to Class 2-C (centralizing) thread profiles.

Load capacities for Stainless Steel Machine Screw Jacks range from 1,300 to 23,000 pounds. For increased capacity, a 17-4PH hardened worm is available.

METRIC BALL SCREW JACKS

With over twenty-five years of experience manufacturing precision worm gear screw jacks, Nook Industries has expanded the ActionJac™ offering to include metric models providing design engineers a globally accepted product. All the efficiency advantages that come with ball screw technology are available in ActionJac™ Metric Ball Screw Jacks. A full line of IEC motor mounts are available.

TRAPEZOIDAL SCREW JACKS

The ActionJac™ Trapezoid Screw Jacks utilize the same rugged design as the ActionJac™ Machine Screw Jacks. These true metric jacks include a lift shaft with a special trapezoidal thread form. This thread form has been created to stay within ISO standards yet retains the centralizing feature of our 2C acme threads. These jacks may be assembled with IEC motor mounts.

ACCESSORIES

Accessories such as motors, motor mounts, encoders, hand wheels, counters, couplings, miter gear boxes, boots, limit switches, top plates and clevises are available.

NOTE: Units are not to be used as personnel support or movement.

GLOSSARY & TERMS

JACK CONFIGURATIONS

Worm gear screw jacks can be assembled in a number of different configurations. The first major configuration divides the jacks into translators and rotators.

TRANSLATING JACKS

A translating jack has a lifting shaft that moves through the gear box. A nut is integrated with the worm gear such that the worm gear and nut rotate together. When the lift shaft is held to prevent rotation, the lift shaft will move linearly through the gear box to move the load.

ROTATING JACKS

A rotating jack has a lift shaft that turns moving a nut. The lift shaft is fixed to the worm gear. This causes the load, which is attached to the travel nut, to move along the lift shaft. (SEE FIG. 1)

Both rotators and translators have an upright and inverted configuration. (SEE FIG. 1)

ANTI-BACKLASH JACKS

Anti-backlash Machine Screw Jacks are used wherever reversible load conditions require precision positioning control. Adjustable backlash Machine Screw Jack models are available to reduce backlash to approximately 0.003".

An Anti-backlash Machine Screw Jack allows the lash between the drive sleeve thread and the lifting screw thread to be accurately controlled by adjusting the top cover of the jack. The anti-backlash jack design has an upper drive sleeve and a lower drive sleeve. Adjustment of the cover changes the relative distance between the drive sleeves. This change in distance compensates for any lash.

Anti-backlash Machine Screw Jacks minimize backlash, but should not

FIG. 1

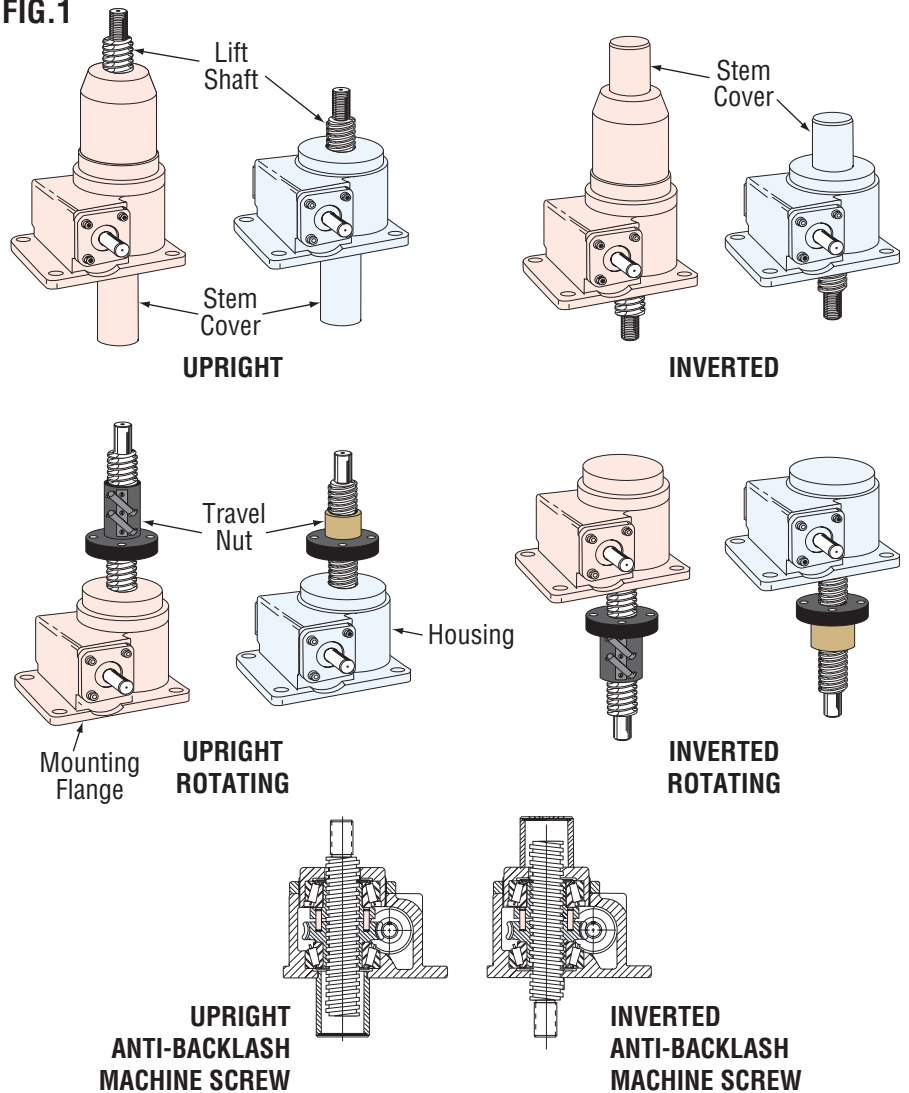

be used to completely eliminate backlash. While it may be desirable to totally eliminate backlash, the result would be a lock-up of lifting shaft and drive sleeve.

Ball Screw Jacks can be factory adjusted to reduce backlash by selecting bearing ball size in the ball nut. This selective fit technique can be used to achieve a lash between the ball nut and ball screw of 0.003"-0.005". Precision ball screws with preloaded ball nuts can be supplied to achieve zero lift shaft backlash. (SEE FIG. 1)

KEYED JACKS

The lift shaft of a translating style jack must be attached to something which prevents the lift shaft from rotating. If it is not, the lift shaft (and the load!) will turn and not translate.

A feature can be added to a machine screw jack to prevent lift shaft rotation. This type of jack is referred to as a "keyed jack" and is available in upright and inverted models.

A keyed jack has a keyway machined along the length of the lifting screw. A matching key is fastened to the cover of the jack which will eliminate lift shaft rotation.

WORM GEAR SCREW JACK TECHNICAL INTRODUCTION

The keyway in the screw causes greater than normal wear on the internal drive sleeve threads, somewhat reducing jack life.

Ball Screw Jacks can also be supplied with a device that prevents rotation of the lift shaft. Anti-rotation is accomplished by a square guide attached to the screw translating inside a square stem cover attached to the jack. The square stem tube is supplied with lube fittings.

The illustrations show the different configurations of keyed screw jacks. **(SEE FIG. 2)**

DOUBLE CLEVIS JACKS

Double Clevis Jacks are used when it is necessary to move a load through an arc, such as tracking antennas, hinged doors and air dampers.

Machine Screw and Ball Screw Jacks from 1-ton to 15-ton capacities can be supplied with double clevis mounts. One clevis is mounted on the end of the lift shaft and the other clevis is welded to a heavy duty stem cover which is welded to the housing.

Double clevis designs are available with optional accessories such as boots, motor mounts, right-angle reducers, motors, encoders and rotary limit switches.

To check column strength limitations for each application use the extended pin to pin dimension and the column strength chart on page 294, 316, 335, 346 and 357. For greater column strength consider ActionJac™ Electric Cylinders, pages 365-407.

NOTE: Mounting hardware for double clevis jacks should be specified as heat treated alloy steel clevis pins with at least 100,000 psi ultimate tensile strength. **(SEE FIG. 2)**

FIG.2

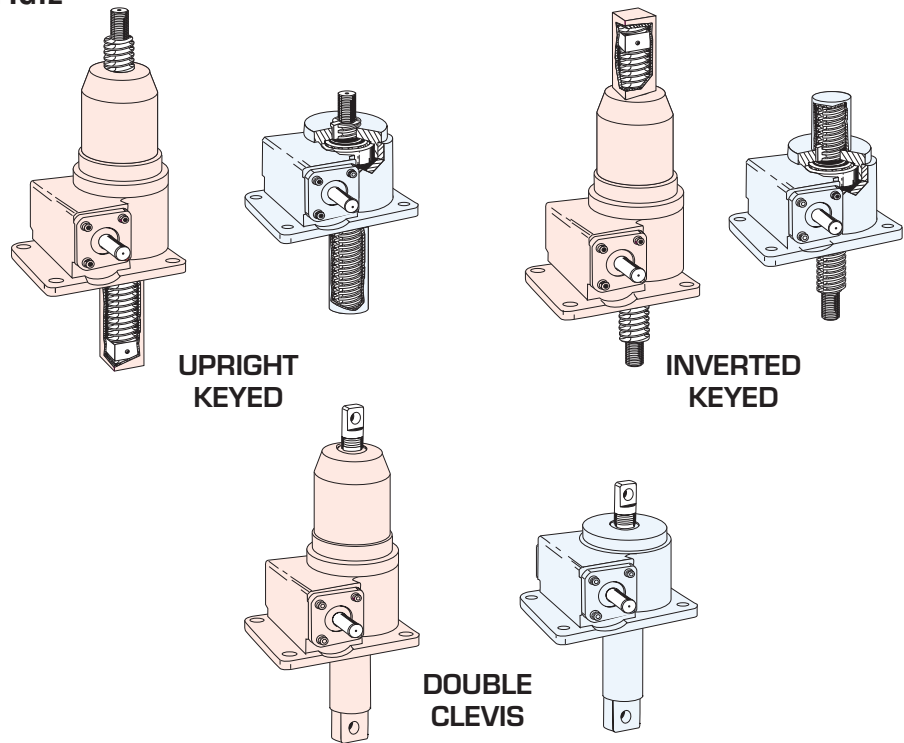

TRAVEL LENGTH

As a manufacturer of lead screws, Nook Industries stocks a broad selection of inch and metric ball, acme and trapezoid screws in long lengths. Jacks are not pre-assembled or stocked with standard length screws. Each jack is made to order based on travel length.

Nook Industries has the capability to manufacture long screws for special applications, limited only by the availability of raw materials. Rotating screw jacks may be assembled with a larger diameter lift screw for greater column strength. Jacks can be supplied with special pitch lift screws to change the jack operating speed.

TWIN LEAD SCREWS

Jacks can also be assembled with twin lead screws if required by the application. Contact the engineers at Nook Industries for availability.

TRAVEL VS. INPUT REVOLUTIONS

The number of turns of the worm required to move one inch is a function of the worm gear ratio and the lead of the screw. The charts at the front of each section give the number of "turns of worm for 1" raise" for each jack. The motor speed divided by this number is the linear speed of the jack lift shaft or travel nut. Conversely, the desired travel rate multiplied by the "turns of worm for 1" raise" equals the input rpm required.

LEAD ACCURACY AND MATCHED LEAD

Lead accuracy is the difference between the actual distance traveled versus the theoretical distance traveled based on lead. For example: A screw with a 0.5 inch lead and ±0.004" per foot lead accuracy rotated 24 times theoretically moves the nut 12 inches.

24 Revolutions X .500 inches per revolution = 12.000 inches of travel with a Lead accuracy of ± 0.004 " per foot, actual travel could be from 11.996 to 12.004 inches.

The rolled thread ball screw, as employed in ActionJac™ products, is held within ± 0.004 " per foot lead error. The rolled acme thread screws used in our machine screw jacks have a typical lead accuracy of ± 0.004 " per foot.

When multiple jacks are used to move a load with precise synchronicity, lift shafts of similar lead accuracy can be factory selected and supplied as sets. Consult factory for matched lead set tolerances.

INPUT TORQUE

The input torque is the rotary force required at the input of the jack to generate an output force at the lift shaft. The product specification pages show the torque necessary to raise one pound. This number multiplied by the load is the required input torque.

Due to static friction, starting or "breakaway" torque can be as much as two to three times running torque. If the load is moved horizontally, the force required to move the load will be lessened in proportion to the coefficient of friction of the surface along which the load is moved. In addition, the force needed to start, stop and hold the load (inertia loading) is provided by the jack. Jack sizing should consider all these forces.

If an application calls for several jacks to be driven together in series, input torque values should be limited to the three times the rated value of the first jack. For multiple high lead ball screw jacks or belt/chain driven jacks contact Nook Industries for allowable input torque values. Multiple jacks driven in a series may require operation at reduced load.

TARE DRAG TORQUE

The gear box components (bearings, seals and grease) in a jack add "tare drag". The product specification pages show the tare drag torque. When loading ActionJac™ Worm Gear Screw Jacks with loads less than 25% of their rated capacity, tare drag torque needs to be added to the torque requirement.

INPUT SPEED

ActionJac™ Worm Gear Screw Jacks are rated for up to 3,000 rpm input speed, provided horsepower and temperature ratings are not exceeded. Contact Nook Industries engineers if higher input speeds are required.

DUTY CYCLE

Duty cycle is the ratio of run time to total cycle time. Some of the mechanical energy input to a worm gear screw jack is converted into heat caused by friction. The duty cycle is limited by the ability of the worm gear screw jack to dissipate heat. An increase in temperature can affect the properties of some components resulting in accelerated wear, damage and possible unexpected failure.

Maximum allowable horsepower ratings (see product specification pages) are based on intermittent operation. The approximate allowable duty cycles are:

- Ball Screw Jacks= 35%
- Machine Screw Jacks= 25%

HOUSING TEMPERATURE

Housing temperature should be monitored and kept below 200°F maximum. Continuous or heavy-duty operation is possible by de-rating the jack capacity, external cooling of the unit or through the use of a recirculating lubrication system.

SELF-LOCKING AND BRAKES

Self-locking occurs when system efficiencies are low enough that the force on the lifting shaft cannot cause the drive system to reverse direction. Machine Screw Jacks having gear ratios between 20:1 and 32:1, are self-locking and, in the absence of vibration, will hold loads without backdriving. All other ratios may require a brake to prevent backdriving.

All Ball Screw Jacks can backdrive and require some means of holding the load, such as a brake on the motor. The product specification pages show holding torque values. Holding torque represents the amount of input torque required to restrain the load.

In addition to back driving, system inertia usually results in some over travel when the motor is switched off. The inertia of the system should be considered when determining the brake size required to stop a dynamic load.

TEMPERATURE

All Actionjac™ Worm Gear Screw Jacks are suitable for operation within the specified limits provided that the housing temperature is not lower than -20°F or higher than +200°F. Factory supplied grease in standard units will operate in this range. For higher or lower operating temperature ranges contact Nook Industries.

TRAVEL STOPS

Travel stops are not standard. A limit switch and a brake should be used to stop the motor. Mechanical stops can cause damage to the jacks because most electric motors will deliver stall torques much higher than their rated torques and motor inertia can cause severe shock loads. For hand operation, mechanical stops can be provided.



DESIGN CONSIDERATIONS

BALL SCREW VS. MACHINE SCREW JACK

The decision to use a ball screw jack or a machine screw jack is based on the application. For many applications, a ball screw model is the best choice. Ball screw jacks are more efficient and therefore require less power than a machine screw jack in the same application.

For low duty cycle applications, for hand-operated applications, or if backdriving is not acceptable consider a machine screw jack.

Actionjac™ Ball Screw Jacks are preferred for:

- Long travel lengths
- Long, predictable life
- High duty cycles
- Oscillating motion

Actionjac™ Machine Screw Jacks are preferred for:

- Resistance to backdriving
- Vibration environments
- Manual operation
- High static loads

LOAD CAPACITY

All anticipated loads should be within the rated capacity of the jack. Loads on the jack in most applications include: static loads, dynamic or moving loads, cutting forces or other reaction forces and acceleration/deceleration loads.

For shock loads, the peak load must not exceed the rated capacity of the jack, and an appropriate design factor should be applied commensurate with the severity of the shock.

For accidental overloads not anticipated in the design of the system, jacks can sustain without damage the following overload conditions: 10% for dynamic loads, 30% for static loads.

For multiple jack systems, load distribution should be considered. System stiffness, center of gravity, drive shaft windup and lead variation in the lift shafts may result in unequal load distribution. Jacks of varying capacity with equal “turns of worm for 1” travel” may be used to accommodate unequal loading.

HORSEPOWER RATINGS

Maximum horsepower ratings are based on intermittent operation. The approximate duty cycles are:

- Ball Screw Jacks= 35%
- Machine Screw Jacks= 25%

Horsepower is calculated by using the following formula:

$$\text{Horsepower per jack} = \frac{\text{Torque to raise one pound} \times \text{Number of pounds to be raised} \times \text{rpm}}{63,025}$$

The product specification pages show the “torque to raise one pound” value for each jack. Add tare drag torque if operating under 25% rated load.

Horsepower values are influenced by many application specific variables including mounting, environment, duty cycle and lubrication. The best way to determine whether performance is within horsepower limits is to measure the jack temperature. The temperature of the housing near the worm must not exceed 200°F.

Do not exceed the maximum allowable input horsepower for a jack. Many models cannot lift the full rated load at 1,800 rpm. If the horsepower required exceeds the maximum value for the jack selected, several solutions are possible.

- Use a larger jack model to increase the maximum allowable horsepower
- Use a Ball Screw Jack to reduce the power required to do the same work
- Operate at a lower input speed
- Use a right angle reducer to bring the power requirement within acceptable limits

Contact Nook Industries for additional assistance.

COLUMN STRENGTH

Column strength is the ability of the lift shaft to hold compressive loads without buckling. With longer screw lengths, column strength can be substantially lower than nominal jack capacity.

If the lift shaft is in tension only, the screw jack travel is limited by the available screw material or by the critical speed of the screw. Refer to the acme screw and ball screw technical sections for critical speed limitations. If there is any possibility for the lift shaft to go into compression, the application should be sized for sufficient column strength.

Charts are provided in each section to determine the required jack size in applications where the lift shaft is loaded in compression. To use the charts (pages 266, 294, 316, 335, 346, 357) :

Find a point at which the maximum length “L” intersects the maximum load. Be sure the jack selected is above and to the right of that point.

CAUTION: chart does not include a design factor.

DESIGN CONSIDERATIONS

The charts assume proper jack alignment with no bending loads on the screw. Effects from side loading are not included in this chart. Jacks operating horizontally with long lift shafts can experience bending from the weight of the screw.

JACK SIZING DATA

Jacks are limited by two constraints: load capacity and horsepower. The load capacity of the jack is limited by the physical constraints of its components (drive sleeve, lift shaft, bearings, etc.). The horsepower limit of the jack is a result of the ability to dissipate the heat generated from the inefficiencies of its components.

To size a screw jack for these constraints, application information must be collected. The data required is:

- 1) Total Load** – The total load includes static loads, dynamic loads and inertia loads from acceleration and deceleration. Also consider reaction forces received from the load such as drilling or cutting forces when using a jack to move a machine tool.
- 2) Number of Jacks** – The number of jacks used depends on physical size and design of the equipment. Stiffness of the equipment structure and guide system will determine the appropriate number of jacks required. Fewer jacks are easier to drive, align and synchronize.
- 3) Maximum Length** – The maximum length includes travel, housing length, starting/stopping distance, extra length for boots and length to accommodate attachment of the load.

- 4) Travel Rate** – Establishing a travel rate allows for evaluation of critical speed and horsepower limits. Acceleration/deceleration time needs to be considered when determining maximum required travel rate.
- 5) Duty Cycle** – The duty cycle is the ratio of run time to the total cycle time. Long travel jacks may be limited by maximum temperature and not duty cycle.
- 6) Type of Guidance** – Linear motion systems require both thrust and guidance. Jacks are designed to provide thrust only, not to guide the load. Guidance is based on application requirements. The guidance system must be designed to absorb all loads other than thrust.

JACK SELECTION

Once the jack sizing data is collected, a preliminary jack selection can be made and then verified. The steps are:

- 1) Select a size and type of jack,**
Selection should be complete with the configuration (upright, inverted, rotating, etc.), ratio, travel or “L” dimension, boots, lift shaft attachment, motor adapters or reducers.
- 2) Load Per Jack** – Verify that the dynamic and static loads do not exceed the rated capacity of the jack. For multiple jack applications, check the distribution of the load based on the stiffness of the structure and potential uneven loading.
- 3) Horsepower** – Calculate the maximum input horsepower required for each jack. This should not exceed the maximum input horsepower for the model and ratio selected.

For multiple jack arrangements, total horsepower required depends on horsepower per jack, number of jacks, the efficiency of the gear box(es) and the efficiency of the arrangement. Two typical arrangements are: **(SEE FIG. 3)**

The efficiency of the arrangement based on the number of jacks is:

- Two jacks = 95%
- Three jacks = 90%
- Four jacks = 85%
- Six to eight jacks = 80%

The efficiency of each miter gearbox is 90%.

Therefore, motor horsepower requirement for the arrangement:

$$\text{Horsepower Arrangement} = \frac{\text{horsepower per jack} \times \text{Number of jacks}}{\text{Arrangement} \times \text{Efficiency of Each Gearbox}}$$

If the horsepower required exceeds the maximum value for the jack selected, several solutions are possible.

- Use a larger jack model to increase the maximum allowable horsepower
- Use a Ball Screw Jack to reduce the power required to do the same work
- Operate at a lower input speed
- Use a right angle reducer to bring the power requirement within acceptable limits

4) Column Strength – If it is at all possible for the lift shaft to be loaded in compression, check the column strength. Consider cases where a shaft normally loaded in tension may be compressively loaded if it meets an obstruction. Check horizontal applications for compressive loading due to acceleration or deceleration.

If column strength is exceeded for the jack selected, consider the following options:

- Change the jack configuration to put the lift shaft in tension
- Increase size of jack
- For rotating jacks add a bearing mount (like the EZZE-MOUNT™)
- Change the lift shaft mounting condition (e.g. from clevis to top plate)

5) Brakemotor Sizing – Safety is the most important consideration. A brakemotor is recommended for all ActionJac™ products where there is a possibility of injury. Only 20:1 or greater ratio Machine Screw Jacks can be considered self-locking in the absence of vibration.

The horsepower requirements determine the size of the motor. Upon selecting a brake motor, verify that the standard brake has sufficient torque to both hold the load and stop the load.

Caution: High lead ball screw jacks may require larger non-standard brakes to stop the load.

An appropriately sized brake will insure against excessive “drift” when stopping for both the Ball Screw and Machine Screw Jacks.

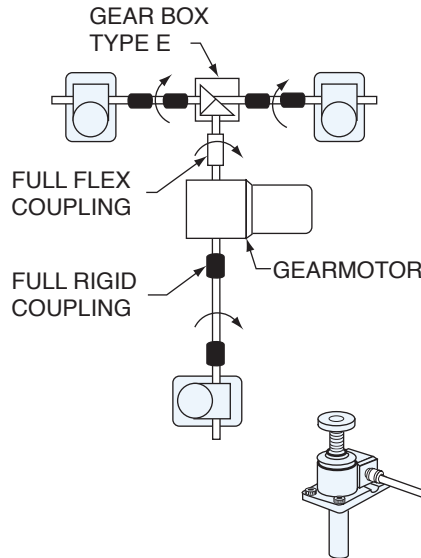
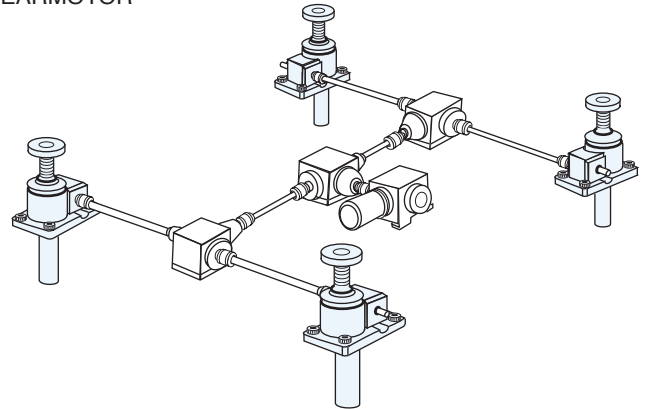

FIG.3



6) Cycle Time – Verify the duty cycle for the selected jack. Recommended duty cycles are:

- Ball screw jacks = 35%
- Machine screw jacks = 25%.

The ability of the jack to dissipate the heat that builds during operation determines duty cycle. Anything that reduces the amount of heat generated or increases heat dissipation will allow higher duty cycles. Jacks may be limited by maximum temperature (200°F) and not duty cycle. Contact Nook Industries for assistance with these applications.

7) Life – For Ball Screw Jacks, verify ball screw life expectancy using the life charts.

Note: Ball screw life charts are located at the beginning of each ball screw jack section. (Page 295 & 347)

INSTALLATION

Alignment of the jack (or jacks) directly affects service life. Jacks must be properly aligned in all planes so that the main drive shaft can be turned without evidence of binding. The following steps are suggested but may not always be applicable when installing jacks. It is the responsibility of the end user to determine specific installation procedures.

1) The mounting flange of the jack is a precision-machined surface. The worm shaft and lift shaft bearing bores are machined in tight relationship to the mounting flange. Better mounting surfaces will make it easier to align the jack to the load.

The surface(s) to which the jacks are mounted should be flat, smooth and perpendicular to the guides. **Note:** for rotating worm gear screw jacks, also ensure that the lift shaft is parallel to the guides.

DESIGN CONSIDERATIONS

- 2) Start with the load temporarily supported in a position closest to the jack housing(s). Locate the jack by putting the jack in place with the fasteners loosely assembled.
- 3) Level the jacks if necessary. For some applications, a piece of compliant material such as the rubber used for machine isolation bases will help compensate for potential misalignment.
- 4) Check the level of the load, then, actuate the jacks bringing the lift shaft or travel nut nearly in contact with the load. Adjust the position of the jacks so that the jack attachment points are centered on the load mounting points. Tighten the jack mounting screws. If a compliant material is installed, make sure that the fasteners do not compress the material and that there is clearance around the fasteners.
- 5) Rotate the worms to adjust the timing of the lift shafts as necessary to equally distribute the load. Assemble the load mounting hardware and tighten.
- 6) Cycle the jacks from closest to farthest point. For rotating jacks with a lift shaft bearing support, loosen the bearing support fasteners and re-tighten to ensure that the lift shaft is parallel to the guide system. Failure to do this could result in lift shaft stress fracture.
- 7) Cycle the jacks again and verify that no binding occurs. Check the lubrication levels, check the limit switch settings (note: rotary limit switches are not factory set), check the tightness of all fasteners and put the jacks in service.

MAINTENANCE

ActionJac™ Worm Gear Screw Jacks require minimum maintenance. In addition to maintaining lubrication levels in the gearbox, the following items should be checked:

Lifting screws must be kept free of contaminants and should be lubricated. Refer to the lubrication section below for appropriate lubrications. If possible, screws should be booted or returned to retracted position when not in use.

For Machine Screw Jacks, lash between the lift shaft and travel nut (or drive sleeve) greater than 1/4 the screw pitch indicates the need for replacement of the jack lift shaft drive components.

For Ball Screw Jacks, the ball screw should be checked periodically for spalling of the raceway. In normal operation, ball screw lash does not change significantly over the life of the ball screw.

For all jacks, check the backlash between the worm and worm gear. Lash in excess of 30° for ratios 5:1 to 8:1 and 60° for ratios 20:1 and 32:1 indicates the need to replace the worm and worm gear.

LUBRICATION

ActionJac™ Worm Gear Screw Jacks require lubrication to operate efficiently and with maximum life. Standard lubrication is NLGI #1 grease. Lubricants are available for both high and low temperature application. If operating conditions exceed 200° F. or -20° F., contact Nook Industries for alternative lubricants.

The jack gear boxes are shipped pre-greased unless otherwise specified. Before operating any unit, check the lubricant level. All jack housings are furnished with a grease fitting. Most have

a pipe plug opposite the grease fitting. When adding grease to the housing, remove the pipe plug and fill the unit until grease exits the pipe plug opening. Over filling the jack may result in grease leakage from the worm shaft seals.

In normal operation, jack lubricant levels should be checked once per month. Application conditions may dictate a more or less frequent lubrication cycle. In extreme conditions, automatic lubrication may be desired.

Lubricants containing additives such as molydisulfide or graphite should not be used.

Ball Screw models need only a light film of lubricant on the lift shaft for most applications. Nook E-900 Ball Screw Lubricant may be applied with a cloth or spray. Operating a Ball Screw Jack lift shaft without lubrication will result in a ninety percent reduction in life.

E-900 BALL SCREW LUBRICANT

page 95



E-100 & PAG-1 LEAD SCREW LUBRICANT

page 14





Application #1 – EXTRUDER SYSTEM

A manufacturer of candy is retrofitting an extruding machine. The machine presently uses a hydraulic ram attached to a plunger to push a thick candy mixture through a dispensing tube into a mold. The manufacturer is concerned with contamination from leaking hydraulics and would like more consistency in the dispensing rate and volume.

SPECIFICATIONS:

- Force to push the candy is 5400 pounds (no load on retraction)
- Force is vertical and will put the jack lift shaft in compression
- Minimum speed is 2.25 inch per second
- Actuation cycle: 50 times/hour, 8 hours/day, 200 days/year
- Desired design life is two years
- Mechanism must be mounted overhead
- Maximum stroke is 15 inches
- Food processing plant requires cleanliness

ANALYSIS:

Configuration: Speed, duty cycle and orientation of the operation dictates the use of an inverted ball screw jack. The plunger mechanism will be attached to the travel nut of a rotating jack.

Column Strength: Using the application data, 5,400 pound load, 15 inch travel with an “L” dimension of 21 inches, assume mounting condition “A,” the column strength chart shows that the a five ton or larger jack will handle the compressive load.

Speed and Horsepower: The 0.473 inch lead lift shaft in a 5 ton ball screw jack will provide the proper speed:

$$2.25 \text{ inches per second} \times 60 \text{ seconds per minute} \times 12.66 \text{ "turns of worm for 1" raise} = 1709 \text{ input rpm.}$$

$$\text{Horsepower required (Torque to raise one pound (from chart) X Load (lbs) X Worm Speed (rpm)/63,025} = (.0183 \times 5,400 \text{ pounds} \times 1,750) / 63,025 = 2.74 \text{ Horsepower}$$

2.74 Horsepower is below the three horsepower limit for this jack. Use a brake motor rated for 3 hp at 1750 rpm for this application.

Life: The life, based on the Ball Screw Life Expectancy chart on page 295, is at least 8,121,000 inches of travel for a standard inverted rotating 5 ton jack with a 5,400 lbs load.

$$\text{Calculated life is } 15 \text{ loaded inches per cycle} \times 50 \text{ cycles per hour} \times 8 \text{ hours per day} \times 200 \text{ days per year} = 1,200,000 \text{ inches per year or } 6.7 \text{ years of life} (= 8.1/1.2).$$

SELECTION:

Reference Number: From page 296, put together a reference number for the following: 5 ton ball screw jack, inverted rotating configuration, 6:1 worm gear ratio, motor mount with 3 hp 3 phase motor on the input shaft, standard extension for the output shaft, flange base, travel nut orientation “A”, “L” dimension of 21” for a 15” travel. Lastly the jack will be modified to include food grade grease and epoxy paint.

5-BSJ-IR 6:1/30BT-1/SSE-2/FA/21/M

M= Modified (food grade grease and epoxy paint)

Application #2 – MACHINE TOOL FIXTURE LOADER

A manufacturer is building a system to position a machine tool table horizontally inside the machine.

SPECIFICATIONS:

- The table is well guided and weighs 4,000 pounds
- The fixture needs accurate and repeatable positioning
- The table moves only a few times per shift.
- Stroke length is 30 inches maximum
- Desired design life is two years
- Thrust can only be applied at two corners
- No specific speed requirements

ANALYSIS:

Configuration: Infrequent operation suggests a machine screw jack. Application arrangement, available clearance and good guidance allow the use of upright translating jacks. The jacks must have an adjustable anti-backlash feature to assure accurate bidirectional positioning. Two manually operated jacks will be used, connected with a common driveshaft.

Column Strength: Even though the unit is horizontal, column strength must still be considered. Using the application data (4000 pound load, 30 inch travel, assume mounting condition “C”) with the column strength chart shows that a 2 ton upright jack with 1” diameter screw will handle the potential compressive load of 2000 lb per jack.

Input Torque: This is a horizontal, manually operated system. The force required to move the load is the actual load times the coefficient of friction of the guide system. For example, if linear bearings were used, the force required to move the load would be equal to 4000 pounds times .002 or 8 pounds. The torque required to move 8 pounds with a 6:1 ratio jack is 0.0250 times 8 or .2 in-lbs. This could easily be supplied by an operator turning a handwheel.

SELECTION:

Reference Number: From page 289, put together a reference number for the following: 2 ton anti-backlash machine screw jack, upright translating configuration, 6:1 worm gear ratio, standard shaft extensions for the worm shaft input and output, Flange base, clevis end on the lift shaft with 30” travel. An interconnecting shaft will be installed between the jacks at assembly to drive the jacks from a common handwheel.

2AB-MSJ-U 6:1/SSE-1/SSE-2/FC/30/S



LOAD

Total Maximum Thrust Load on Jack(s): _____ pounds force Number of Jacks: _____
Maximum Thrust Load on any one Jack: _____ pounds force
(Note: load can rarely be assumed to be equal on all jacks)

TRAVEL

Inches: _____ Orientation: vertical horizontal other (arc, diagonal, etc)

TRAVEL RATE

Optimal Speed: _____ inches/minute
Minimum Acceptable Speed: _____ inches/minute
Maximum Acceptable Speed: _____ inches/minute

DUTY CYCLE

Distance per cycle: _____ inches (One cycle = extend and retract)
Number of cycles per time period: _____ cycles per _____
Maximum Distance Traveled in any Year: _____ inches
Life Desired: _____
(Important: If load varies significantly, please explain below.)

OPERATION

Jack Screws are Loaded in: Tension Compression Both
Jack will be Driven by: Hand AC Induction motor Other Type of motor (describe)

APPLICATION EXPLANATION

Please briefly describe the application. State type of machine, function of jack(s), load guidance system and environment (shock or impact loading, vibration, temperature extremes, corrosive, dirty, or other extreme operating conditions). Attach any sketches and other relevant information. Also, if a tentative selection has been made, please give the reference number or model and description below.
