

Standard AC Motors

Constant Speed Motors

# Low-Speed Synchronous Motors

Low-Speed Synchronous Motors

Introduction

Induction Motors

Reversible Motors

Electromagnetic Brake Motors

V Series

Clutch & Brake Motors

Synchronous Motors

Low-Speed Synchronous Motors

Waterright, Dust-Resistant Motors

Torque Motors

Right-Angle Gearheads

Linear Heads

Brake Pack

Accessories

Installation

# Low-Speed Synchronous Motors SMK Series

● Additional Information ●  
 Technical reference → Page G-1  
 Safety standards → Page H-2

Low-speed synchronous motors are continuous rated synchronous motors in which quick bi-directional rotation is possible. The basic construction of low-speed synchronous motors is the same as that of stepping motors. Since they can be driven by an AC power supply, they are sometimes called AC stepping motors.



● For detailed product safety standard information including standards, file number and certification body, please visit [www.orientalmotor.com](http://www.orientalmotor.com).

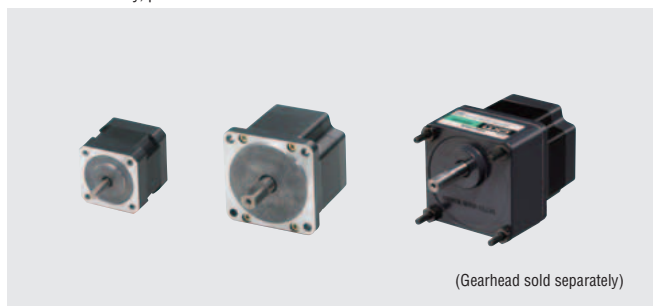

## Features

### ● Low-Speed / Synchronous Rotation

The motor rotates at a speed proportional to and accurately synchronized with the frequency of the power supply.

A fluctuation in load does not affect the rotation speed.

At 50 Hz 60 r/min (30 r/min)\*

At 60 Hz 72 r/min (36 r/min)\*

\*For **SMK014MA-A**

### ● Continuous Rated Capacitor-Run Motor

This is a capacitor-run motor that can be driven by a capacitor only (An external resistance is needed for **SMK5** type). This can be driven at a continuous rating even when bi-directional operation is required.

### ● Superb Starting, Stopping and Reversing Characteristics

If operated within the permissible load inertia, the motor can start, stop and reverse within 1.5 cycles (0.03 sec at 50 Hz, 0.025 sec at 60 Hz) of power supply frequency.

◇ Suitable for equipment that starts and stops repeatedly such as conveyors.

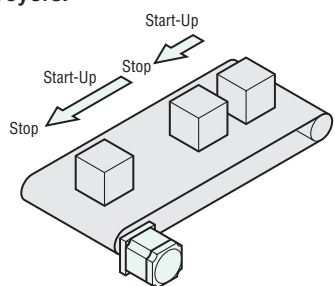

◇ Bi-directional operation can be repeated continuously.

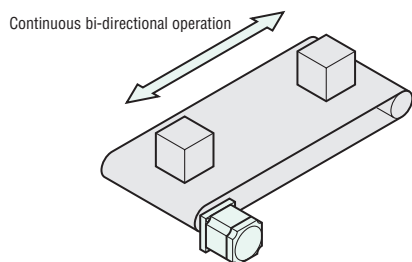

### ● Precise Positioning

The motor can be stopped instantly by turning off the power supply. The stopping accuracy within the motor's permissible load inertia is  $\pm 10^\circ$ .

### ● Vertical Applications

Constant speed can be maintained even during gravitational operations. Low-speed synchronous motors are suitable for applications, such as an elevator system, whereby vertical operation at a constant speed is required.

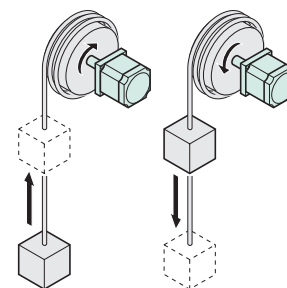

### ● Holding Torque

Since a permanent-magnet, multi-poled rotor is used, the motor has holding torque even when the motor is not energized. When used with a gearhead, comparatively high holding torque can be utilized.

● When, at motor standstill, a DC power supply is used, a large holding torque almost equal to that of a stepping motor can be produced.  
 DC Excitation → Page C-201

### ● Long Life, Low Noise **GN-S** Gearhead is Available

The "long life, low noise **GN-S** gearhead" achieves a long rated life of 10000 hours, twice the level of a conventional gearhead, by adopting innovative technologies and structure. The gearhead is also designed for low noise.

● Details of long life, low noise **GN-S** gearhead → Page C-21

● **SMK0A-□A** indicates a geared motor consisting of a special gearhead and a motor. The gearhead cannot be replaced.

## System Configuration

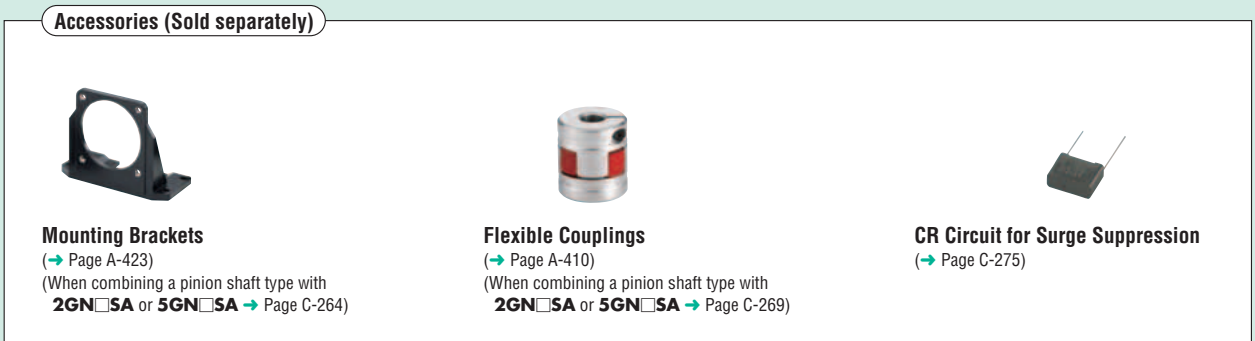
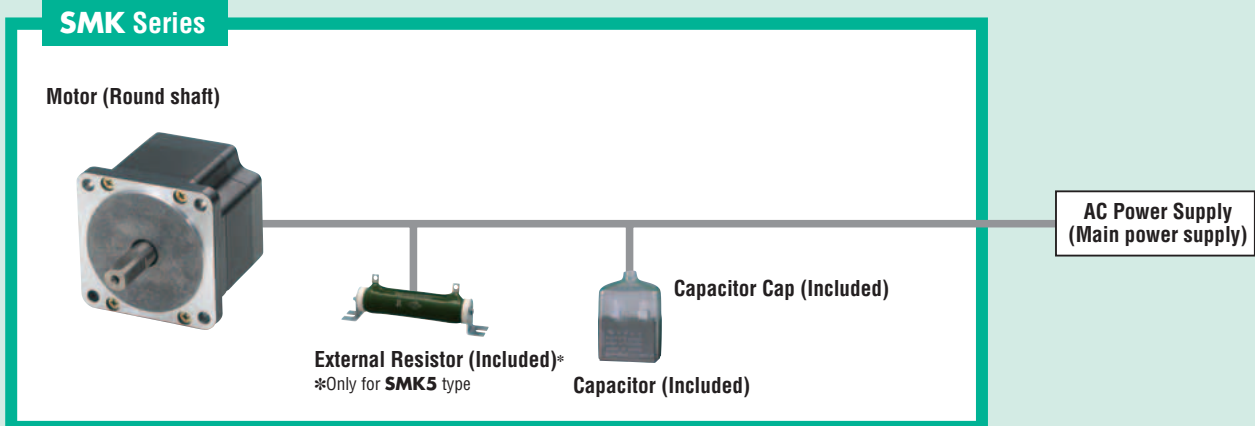

### ● Example of System Configuration

<b>SMK Series</b> (Round shaft)  <b>SMK237A-A</b>	+	Sold Separately	
		Mounting Bracket <b>PAL2P-2</b>	Flexible Coupling <b>MCS2006F04</b>

● Gearheads cannot be combined with round shaft type motors.

● The system configuration shown above is an example. Other combinations are available.

## Product Number Code

### Motor

**SMK 0 14 M A - A**

①    ②    ③    ④    ⑤    ⑥

①	Series	<b>SMK: SMK</b> Series
②	Motor Frame Size	<b>0:</b> 42 mm (1.65 in.) <b>2:</b> 56.4 mm (2.22 in.) [ <b>GN</b> Pinion Shaft Type 60 mm (2.36 in.)] <b>5:</b> 85 mm (3.35 in.) [ <b>GN</b> Pinion Shaft Type 90 mm (3.54 in.)]
③	Motor Torque	<b>14:</b> 0.14 N·m (19.8 oz-in.) <b>16:</b> 0.16 N·m (22 oz-in.) <b>37:</b> 0.37 N·m (52 oz-in.) <b>50:</b> 0.5 N·m (71 oz-in.) <b>100:</b> 1.0 N·m (142 oz-in.) <b>160:</b> 1.6 N·m (220 oz-in.)
④	Speed	Blank: 60/72 r/min (50/60 Hz) <b>M:</b> 30/36 r/min (50/60 Hz)
⑤	Power Supply Voltage	<b>A:</b> Single-Phase 100/115 VAC
⑥	Motor Shaft Type	<b>A, AA:</b> Round Shaft <b>GN:</b> <b>GN</b> Type Pinion Shaft

### Gearhead

**5 GN 50 SA**

①    ②    ③    ④

①	Gearhead Frame Size	<b>2:</b> 60 mm (2.36 in.) <b>5:</b> 90 mm (3.54 in.)
②	Type of Pinion	<b>GN:</b> <b>GN</b> Type Pinion
③	Gear Ratio	(Example) <b>50:</b> Gear Ratio of 50:1
④	<b>SA:</b> Long Life, Low Noise <b>GN-S</b> Gearhead	

### Geared Motor

**SMK 0 A - 120 A**

①    ②    ③    ④    ⑤

①	Series	<b>SMK: SMK</b> Series
②	Motor Frame Size	<b>0:</b> 42 mm (1.65 in.)
③	Power Supply Voltage	<b>A:</b> Single-Phase 100/115 VAC
④	Gear Ratio	(Example) <b>120:</b> Gear Ratio of 120:1
⑤	Motor Shaft Type	<b>A:</b> Single Shaft

## Product Line

### Motor (RoHS)

Power Supply Voltage	Shaft Type	Model
Single-Phase 100/115 VAC	Round Shaft	<b>SMK014A-A</b>
		<b>SMK014MA-A</b>
		<b>SMK237A-A</b>
		<b>SMK5100A-AA</b>
	<b>GN</b> Type Pinion Shaft	<b>SMK5160A-AA</b>
		<b>SMK216A-GN</b> <b>SMK550A-GN</b>

### Geared Motor (RoHS)

Power Supply Voltage	Model	Gear Ratio
Single-Phase 100/115 VAC	<b>SMK0A-□A</b>	<b>3, 3.6, 7.5, 9, 15, 18, 30, 36, 50, 60, 100, 120</b>

The following items are included in each product.  
 Motor, Capacitor, Capacitor Cap, External Resistor\*, Operating Manual  
 \*Only for **SMK5** type

### Parallel Shaft Gearhead (Sold separately)

#### ◇ Long Life, Low Noise **GN-S** Gearhead (RoHS)

Applicable Motor (Pinion shaft)	Model	Gear Ratio
Frame Size □60 mm (□2.36 in.)	<b>2GN□SA</b>	<b>3, 3.6, 5, 6, 7.5, 9, 12.5, 15, 18, 25, 30, 36, 50, 60, 75, 90, 100, 120, 150, 180</b>
Frame Size □90 mm (□3.54 in.)	<b>5GN□SA</b>	

The following items are included in each product.  
 Gearhead, Mounting Screws, Operating Manual

The following gearheads are also available. For details, please refer to website ([www.orientalmotor.com](http://www.orientalmotor.com)) or contact the nearest Oriental Motor sales office.

Gearhead Type	Gearhead Model	Gear Ratio
Parallel Shaft	(RoHS) <b>GN-K</b> Gearhead	<b>2GN□KA</b> <b>5GN□KA</b>
		<b>3~180</b> <b>3~180</b>

Enter the gear ratio in the box (□) within the model name.

## Specifications – Continuous Rating

● Motor (RoHS)



Model	Voltage VAC	Frequency Hz	Current A	Torque N·m (oz-in)	Speed r/min	Holding Torque mN·m (oz-in)	Rotor Inertia J kg·m <sup>2</sup> (oz-in <sup>2</sup> )	Capacitor μF	External Resistor	
									Ω	W
ZP SMK014A-A	Single-Phase 100	50	0.043	0.11 (15.6)	60	9 (1.27)	55×10 <sup>-7</sup> (0.3)	0.6	-	-
		60	0.046	0.12 (17.0)	72					
ZP SMK014MA-A	Single-Phase 115	60	0.053	0.13 (18.4)	72	4.5 (0.63)	55×10 <sup>-7</sup> (0.3)	0.6	-	-
		50	0.043	0.11 (15.6)	30					
ZP SMK237A-A	Single-Phase 100	60	0.046	0.12 (17.0)	36	25 (3.5)	300×10 <sup>-7</sup> (1.64)	1.2	-	-
		60	0.053	0.13 (18.4)	36					
ZP SMK216A-GN	Single-Phase 100	50	0.08	0.37 (52)	60	15 (2.1)*	120×10 <sup>-7</sup> (0.66)	1.2	-	-
		60	0.09	0.37 (52)	72					
		60	0.10	0.37 (52)	72					
ZP SMK5100A-AA	Single-Phase 100	50	0.17	1.0 (142)	60	36 (5.1)	1400×10 <sup>-7</sup> (7.7)	2.5	400	30
		60	0.20	1.0 (142)	72					
		60	0.21	1.1 (156)	72					
ZP SMK5160A-AA	Single-Phase 100	50	0.23	1.6 (220)	60	89 (12.6)	2700×10 <sup>-7</sup> (14.8)	2.5	400	30
		60	0.26	1.8 (250)	72					
		60	0.28	2.1 (290)	72					
ZP SMK550A-GN	Single-Phase 100	50	0.06	0.5 (71)	60	36 (5.1)*	1400×10 <sup>-7</sup> (7.7)	0.6	400	30
		60	0.07	0.5 (71)	72					
		60	0.07	0.5 (71)	72					

\* To calculate holding torque for gearmotors, use the following formula: listed holding torque × gear ratio.  
Note that the gearmotor holding torque should be lower than the permissible torque on the gear output shaft.

● SMK014 type is not a standard certified product.

● ZP: Impedance protected.

● Geared Motor (RoHS)

Model	Voltage VAC	Frequency Hz	Current A	Speed*1 r/min	Holding Torque*2 mN·m (oz-in)	Rotor Inertia J kg·m <sup>2</sup> (oz-in <sup>2</sup> )	Capacitor μF
ZP SMK0A-□A	Single-Phase 100	50	0.043	60	9 (1.27)	55×10 <sup>-7</sup> (0.3)	0.6
		60	0.046	72			
		60	0.053	72			

\*1 50 Hz: Gear output shaft speed = 60/Gear Ratio [r/min]

60 Hz: Gear output shaft speed = 72/Gear Ratio [r/min]

\*2 To calculate holding torque for gearmotors, use the following formula: listed holding torque × gear ratio.

Note that the gearmotor holding torque should not exceed the permissible torque on the gear output shaft.

● Gearmotor — Torque Table → Page C-196

● Enter the gear ratio in the box (□) within the model name.

● ZP: Impedance protected.

## General Specifications

Item	Specifications
Insulation Resistance	100 MΩ or more when 500 VDC megger is applied between the windings and the case after rated operation under normal ambient temperature and humidity.
Dielectric Strength	Sufficient to withstand 1.5 kVAC at 50 Hz or 60 Hz applied between the windings and the case for 1 minute after rated operation under normal ambient temperature humidity.
Temperature Rise	Temperature rise of motor case is 55°C (99°F) or less measured by thermometer method after rated operation under normal ambient temperature and humidity.
Thermal Class	UL/CSA standards: 105 (A), EN standards: 120 (E)
Overheat Protection	Impedance protection
Ambient Temperature	-10~+40°C (+14~+104°F) (non-freezing)
Shaft Runout	0.05 mm (0.002 in.) T.I.R.*1
Concentricity	0.075 mm (0.003 in.) T.I.R.*1
Perpendicularity	0.075 mm (0.003 in.) T.I.R.*1
Shaft Radial Play*2	0.025 mm (0.001 in.) maximum [Load 5 N (1.12 lb.)]
Shaft Axial Play*3	0.075 mm (0.003 in.) maximum [Load 10 N (2.2 lb.)]
Step Accuracy	±3.6°

\*1 T.I.R. (Total Indicator Reading): The total dial gauge reading when the measurement section is rotated one rotation centered on the reference axis center.

\*2 Radial Play: Displacement in shaft position in the radial direction, when a 5 N (1.12 lb.) load is applied in the vertical direction to the tip of the motor's shaft.

\*3 Axial Play: Displacement in shaft position in the axial direction, when a 10 N (2.2 lb.) load is applied to the motor's shaft in the axial direction.

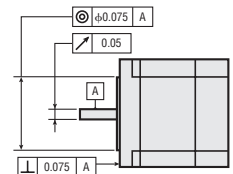

## Gearmotor – Torque Table

### Motor/Gearhead

Unit = Upper values: N-m/Lower values: lb-in

Model \ Gear Ratio	3	3.6	5	6	7.5	9	12.5	15	18	25	30	36	50	60	75	90	100	120	150	180	
	<b>SMK216A-GN/2GN□SA</b>	0.40 3.5	0.50 4.4	0.70 6.1	0.80 7	1.0 8.8	1.2 10.6	1.5 13.2	1.8 15.9	1.9 16.8	2.1 18.5	2.4 21	2.8 24	3 26	3 26	3 26	3 26	3 26	3 26	3 26	3 26
<b>SMK550A-GN/5GN□SA</b>	1.4 12.3	1.7 15.0	2.3 20	2.8 24	3.5 30	4.3 38	4.5 39	5.0 44	6.0 53	7.5 66	9.0 79	9.0 79	10 88	10 88	10 88	10 88	10 88	10 88	10 88	10 88	10 88

● A colored background (□) indicates gear shaft rotation in the same direction as the motor shaft, while the others rotate in the opposite direction.

### Geared Motor

Unit = Upper values: N-m/Lower values: lb-in

Model \ Gear Ratio	3	3.6	7.5	9	15	18	30	36	50	60	100	120
	<b>SMK0A-□A</b>	0.15 1.32	0.18 1.59	0.35 3.0	0.35 3.0	0.35 3.0	0.35 3.0	0.35 3.0	0.37 3.2	0.41 3.6	0.47 4.1	0.47 4.1

● A colored background (□) indicates gear shaft rotation in the same direction as the motor shaft, while the others rotate in the opposite direction.

## Permissible Overhung Load and Permissible Thrust Load

### Motor, Geared Motor

Unit = N (lb.)

Motor Model	Permissible Overhung Load					Permissible Thrust Load
	Distance from Shaft End					
	0 mm (0 in.)	5 mm (0.2 in.)	10 mm (0.39 in.)	15 mm (0.59 in.)	20 mm (0.79 in.)	
<b>SMK014</b>	20 (4.5)	25 (5.6)	34 (7.6)	52 (11.7)	–	The permissible thrust load shall be no greater than the motor mass.
<b>SMK237</b>	54 (12.1)	67 (15)	89 (20)	130 (29)	–	
<b>SMK5100, SMK5160</b>	260 (58)	290 (65)	340 (76)	390 (87)	480 (108)	
<b>SMK0A-□</b>	10 (2.2)	15 (3.3)	20 (4.5)	30 (6.7)	–	

### Gearhead

Unit = N (lb.)

Model	Gear Ratio	Overhung Load		Permissible Thrust Load
		Distance from Shaft End [mm (in.)]		
		10 mm (0.39 in.)	20 mm (0.79 in.)	
<b>2GN□SA</b>	<b>3~18</b>	50 (11.2)	80 (18)	30 (6.7)
	<b>25~180</b>	120 (27)	180 (40)	
<b>5GN□SA</b>	<b>3~18</b>	250 (56)	350 (78)	100 (22)
	<b>25~180</b>	300 (67)	450 (101)	

● Enter the gear ratio in the box (□) within the model name.

## Permissible Load Inertia J

Starting, stopping and reversing characteristics vary according to the amount of load inertia directly coupled to the motor. Permissible load inertia, therefore, refers to the upper limit of load inertia under which the motor can be operated normally when the load is connected directly to the motor shaft. When the amount of load inertia is too great, the motor may vibrate or reverse direction. It is recommended to use flexible couplings when connecting the load to the motor shaft.

## Permissible Load Inertia J of Motors

Model	Permissible Load Inertia J ×10 <sup>-4</sup> kg·m <sup>2</sup> (oz-in <sup>2</sup> )
<b>SMK014A-A</b>	0.275 (1.50)
<b>SMK014MA-A</b>	
<b>SMK237A-A</b>	2.5 (13.7)
<b>SMK5100A-AA</b>	7 (38)
<b>SMK5160A-AA</b>	12 (66)

## Permissible Load Inertia J of Gearhead

### Motor/Gearhead

Unit = Upper values: ×10<sup>-4</sup>kg·m<sup>2</sup>/Lower values: oz-in<sup>2</sup>

Model \ Gear Ratio	3	3.6	5	6	7.5	9	12.5	15	18	25	30	36	50	60	75	90	100	120	150	180
<b>SMK216A-GN/2GN</b> □SA	5.4 30	7.7 42	15 82	21.6 118	33.7 184	48.6 270	93.7 510	135 740	155 850	155 850	155 850	155 850	155 850	155 850	155 850	155 850	155 850	155 850	155 850	155 850
<b>SMK550A-GN/5GN</b> □SA	63 340	90.7 500	175 960	252 1380	393.7 2200	567 3100	1093 6000	1575 8600	1875 10300	1875 10300	1875 10300	1875 10300	1875 10300	1875 10300	1875 10300	1875 10300	1875 10300	1875 10300	1875 10300	1875 10300

## Geared Motor

Unit = Upper values: ×10<sup>-4</sup>kg·m<sup>2</sup>/Lower values: oz-in<sup>2</sup>

Model \ Gear Ratio	3	3.6	7.5	9	15	18	30	36	50	60	100	120
<b>SMK0A</b> □A	2.4 13.1	3.5 19.2	15 82	22 122	40 220	40 220	40 220	40 220	40 220	40 220	40 220	40 220

## Dimensions Unit = mm (in.)

● Mounting screws are included with gearheads (except for geared motor). Dimensions for mounting screws → Page C-280

### □42 mm (□1.65 in.)

#### Motor

#### SMK014A-A, SMK014MA-A

Mass: 0.3 kg (0.66 lb.)

DXF B301

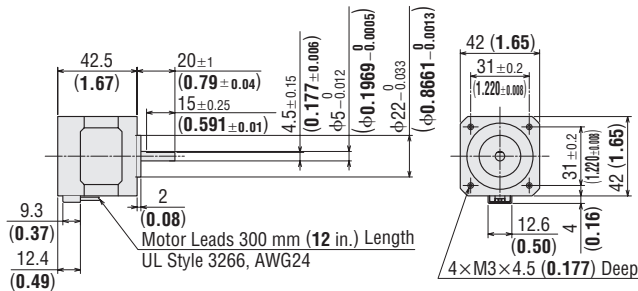

### □56.4 mm (□2.22 in.)

#### Motor

#### SMK237A-A

Mass: 0.7 kg (1.5 lb.)

DXF B126

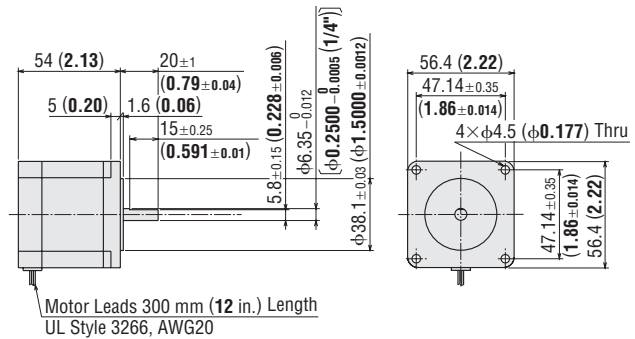

### □85 mm (□3.35 in.)

#### Motor

#### SMK5100A-AA

Mass: 1.7 kg (3.7 lb.)

DXF B127U

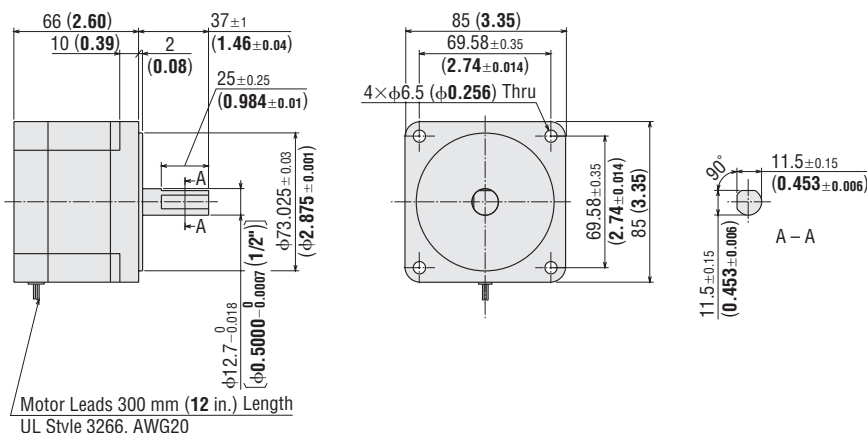

● Enter the gear ratio in the box (□) within the model name.

## ◇ Motor

### SMK5160A-AA

Mass: 2.8 kg (6.2 lb.)

DXF B128U

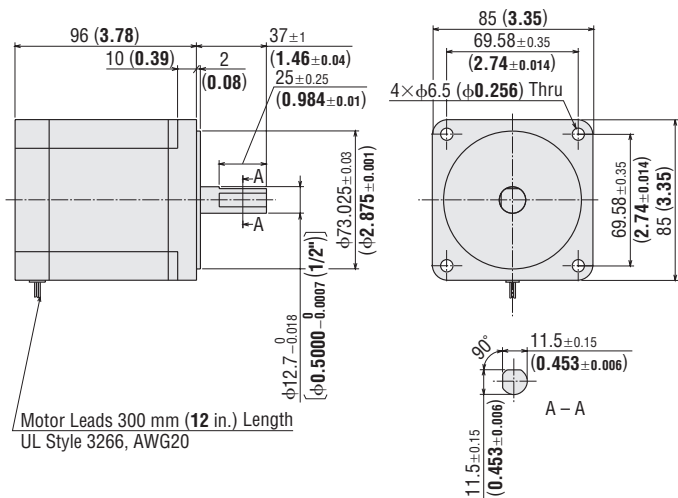

## ● □ 60mm (□ 2.36 in.)

### ◇ Motor/Gearhead

Motor Model	Gearhead Model	Gear Ratio	L	DXF
<b>SMK216A-GN</b>	<b>2GN □ SA</b>	<b>3~18</b>	30 (1.18)	A609AU
		<b>25~180</b>	40 (1.57)	A609BU

Mass: Motor 0.45 kg (0.99 lb.)

Gearhead 0.4 kg (0.88 lb.)

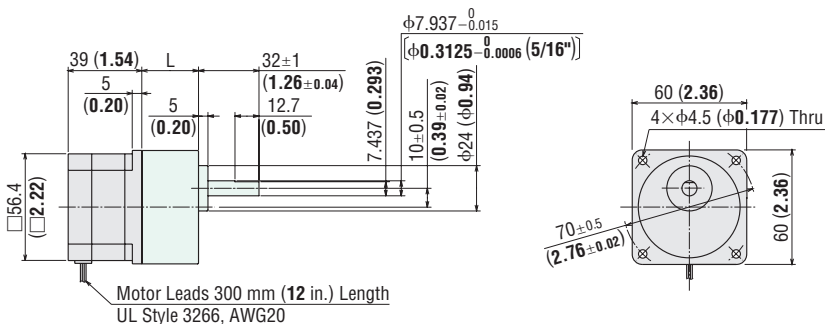

## ● □ 90mm (□ 3.54 in.)

### ◇ Motor/Gearhead

Motor Model	Gearhead Model	Gear Ratio	L	DXF
<b>SMK550A-GN</b>	<b>5GN □ SA</b>	<b>3~18</b>	42 (1.65)	A610AU
		<b>25~180</b>	60 (2.36)	A610BU

Mass: Motor 1.7 kg (3.7 lb.)

Gearhead 1.5 kg (3.3 lb.)

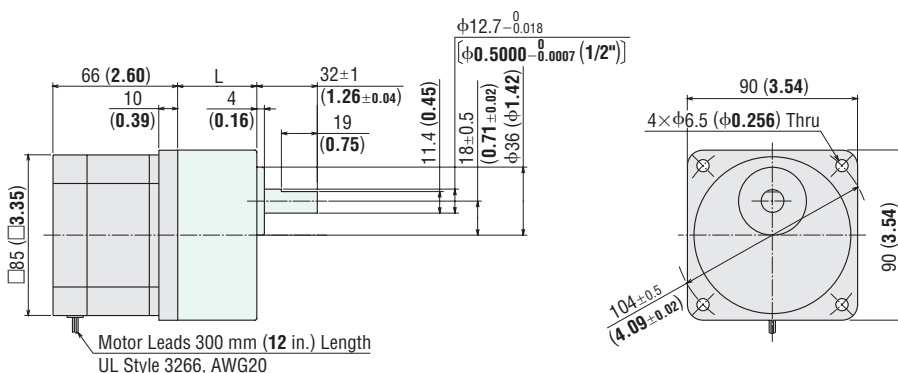

● Enter the gear ratio in the box (□) within the model name.



● □ 42mm (□ 1.65 in.)

◇ Geared Motor

**SMK0A-□A**

Mass: Motor 0.5 kg (1.1 lb.)

**DXF** B323

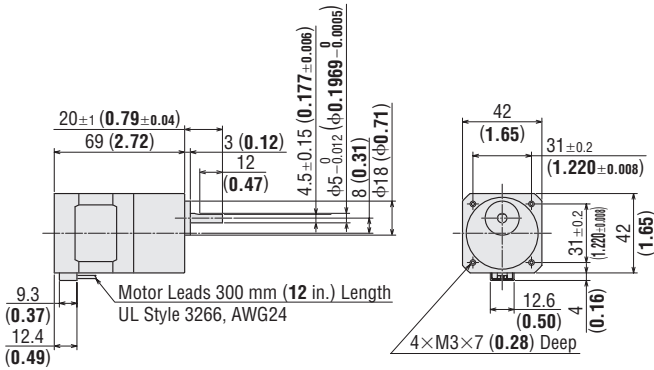

◇ Capacitor (included)

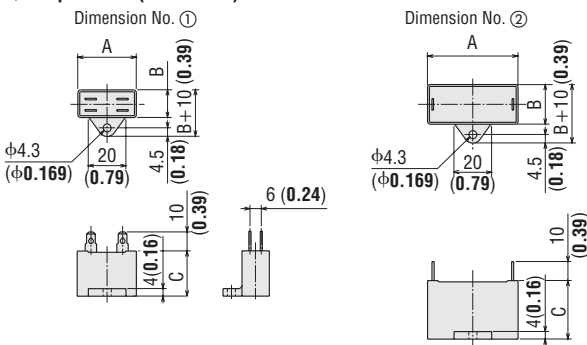

◇ Capacitor Dimensions Unit = mm (in.)

Motor Model	Capacitor Model	A	B	C	Mass g (oz.)	Dimension No.	Capacitor Cap
<b>SMK014A-A</b> <b>SMK014MA-A</b> <b>SMK0A-□A</b>	CH06BFAUL	31 (1.22)	14.5 (0.57)	23.5 (0.93)	15 (0.53)	①	Included
<b>SMK237A-A</b> <b>SMK216A-GN</b>	CH12UL	31 (1.22)	14.5 (0.57)	23.5 (0.93)	17 (0.6)	②	
<b>SMK5100A-AA</b> <b>SMK5160A-AA</b>	CH25UL	31 (1.22)	17 (0.67)	27 (1.07)	20 (0.71)	②	
<b>SMK550A-GN</b>	CH06BUL	31 (1.22)	14.5 (0.57)	23.5 (0.93)	15 (0.53)	②	

◇ External Resistor (included with **SMK5** type only)

Mass: 60 g (2.1 oz.)

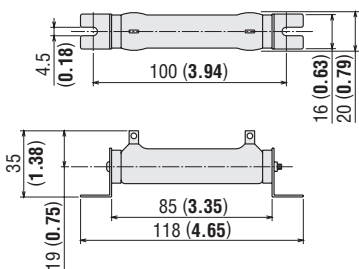

● Enter the gear ratio in the box (□) within the model name.

## Connection and Operation

When the switch is set to "CW", the motor rotates in the clockwise direction. When set to "CCW", the motor rotates in the counterclockwise direction. The motor can be stopped instantly by turning off the power supply. The direction of motor rotation is as viewed from the shaft end of the motor. The capacitor and external resistor (for **SMK5** type only) are included with the motor.

### SMK0 Type

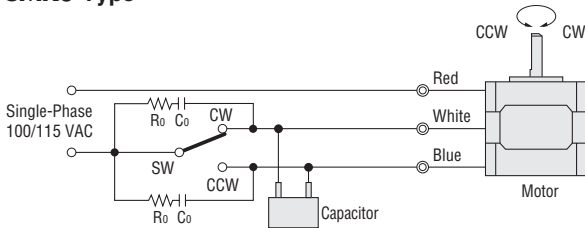

### SMK2 Type

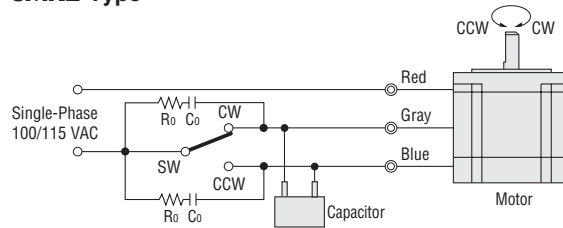

### SMK5 Type

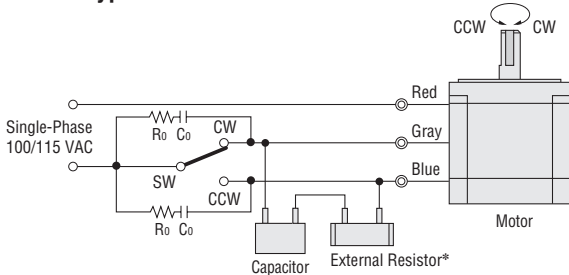

\* Please note that the external resistor may generate heat depending on the operating conditions.

- To protect the contact point of relays and switches, always connect a CR circuit for surge suppression.

The **EPCR1201-2** surge suppressor circuit is available as an accessory.

→ Page C-275

- When the geared motor or **GN** gearheads are used, the rotating direction of output shaft differs depending on the gear ratio. → Page C-196

- How to connect a capacitor → Page C-282

## Starting Time

Low-speed synchronous motors offer superb starting, stopping and reversing characteristics. Provided that the motor is operating within permissible load inertia limits, it can be started, stopped or reversed within 1.5 cycles of the applied frequency. The motor will start and reach a steady speed in the time shown in the table.

As seen in this table, there is a certain amount of variation in the time required for the motor to reach the set speed. This is attributable to factors linked with the phase of the power source and the relative positions of the rotor and stator when the current is applied.

Model	Load Inertia: J		Starting Time (ms)		Stopping Time (ms)	
	kg·m <sup>2</sup>	oz·in <sup>2</sup>	Start Up	Settling	Settle Down	Settling
<b>SMK014A-A</b> <b>SMK014MA-A</b> <b>SMK0A-□A</b>	0	0	2~15	19~37	3~5	7~23
	$137 \times 10^{-7}$	0.75	3~16	25~38	4~7	11~27
	$275 \times 10^{-7}$	1.50	6~22	14~48	5~9	23~32
<b>SMK237A-A</b>	0	0	2~15	19~37	3~5	7~23
	$1250 \times 10^{-7}$	6.8	3~16	25~38	4~7	11~27
	$2500 \times 10^{-7}$	13.7	6~22	14~48	5~9	23~32
<b>SMK216A-GN</b>	0	0	2~15	19~37	3~5	7~23
	$300 \times 10^{-7}$	1.64	3~16	25~38	4~7	11~27
	$600 \times 10^{-7}$	3.3	6~22	14~48	5~9	23~32
<b>SMK5100A-AA</b> <b>SMK550A-GN</b>	0	0	2~15	19~37	3~5	7~23
	$3500 \times 10^{-7}$	19.1	3~16	25~38	4~7	11~27
	$7000 \times 10^{-7}$	38	6~22	14~48	5~9	23~32
<b>SMK5160A-AA</b>	0	0	2~15	19~37	3~5	7~23
	$6000 \times 10^{-7}$	33	3~16	25~38	4~7	11~27
	$12000 \times 10^{-7}$	66	6~22	14~48	5~9	23~32

- Enter the gear ratio in the box (□) within the model number.

## DC Excitation

When a holding torque larger than the static holding torque of the stopped motor is required, apply a DC voltage after turning the AC power supply off.

### Connection Diagrams

#### 1-Phase Excitation

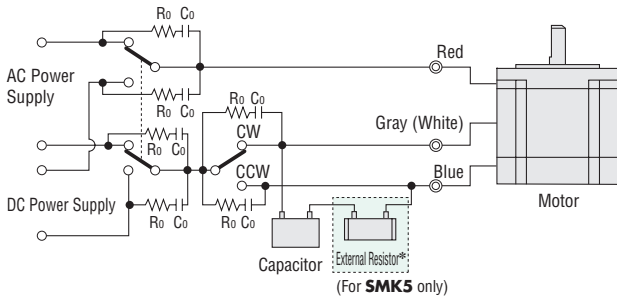

#### 2-Phase Excitation (Series)

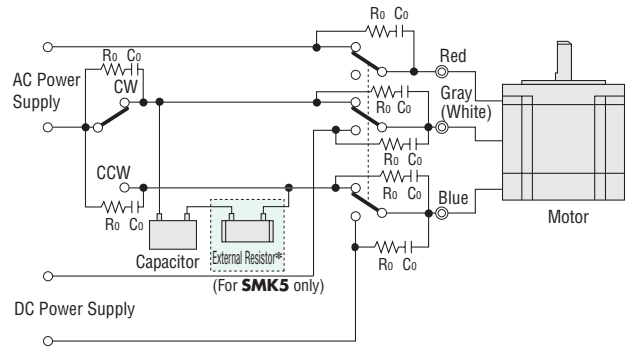

#### 2-Phase Excitation (Parallel)

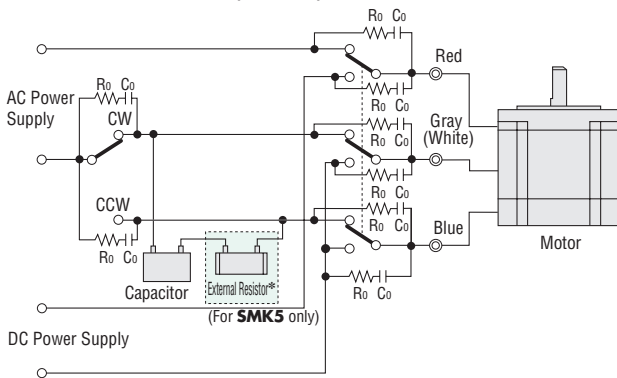

\* Please note that the external resistor may generate heat depending on the operating conditions.

- The white leads listed in parentheses are only for the **SMKO** type.
- Connect the supplied external resistor to the capacitor in series for the **SMK5** type.
- External resistors are not needed for the **SMKO** and **SMK2** types.
- To prevent DC power supply damage caused by voltage surges, connect a surge suppressor circuit between the contact points of the relays and switches.  
The **EPCR1201-2** surge suppressor circuit is available as an accessory. → Page C-275

## ● Characteristics for DC Excitation

- These values apply to the motor only.
- To calculate holding torque for gearmotors, use the following formula: listed holding torque × gear ratio.  
Note that the gearmotor holding torque should not exceed the permissible torque on the gear output shaft.
- Gearmotor – Torque Table → Page C-196
- ---- on the chart indicates permissible applied voltage.

### SMK014A-A, SMK014MA-A

#### SMK0A-□A

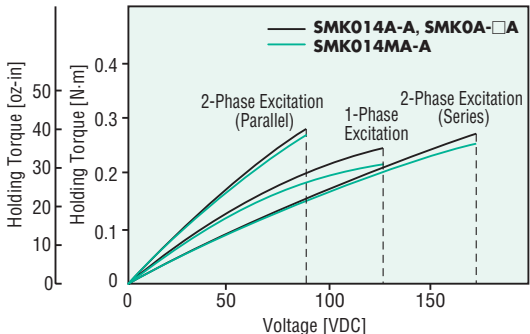

### SMK237A-A, SMK216A-GN

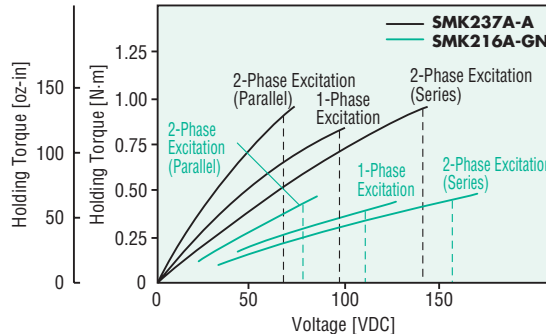

### SMK5100A-AA, SMK550A-GN

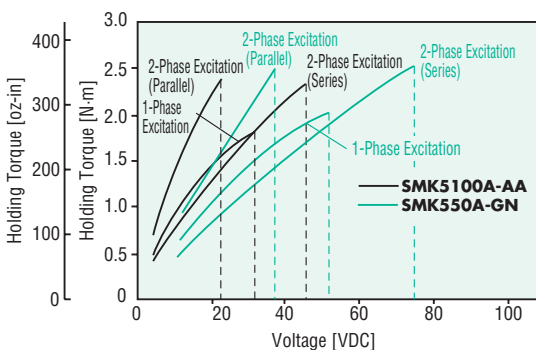

### SMK5160A-AA

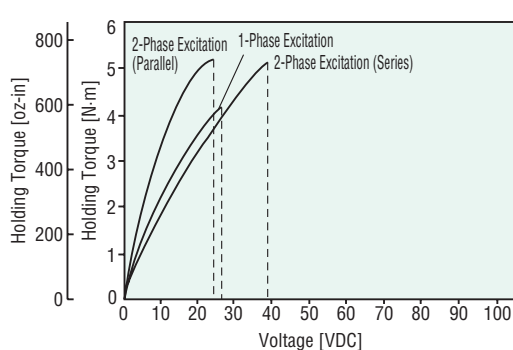

## ◇ DC Power Source Capacity (Reference values)

Model	At 1-Phase Excitation		At 2-Phase Excitation (Series)		At 2-Phase Excitation (Parallel)	
	Safe Excitation Voltage V	Current Required for Power Source A	Safe Excitation Voltage V	Current Required for Power Source A	Safe Excitation Voltage V	Current Required for Power Source A
<b>SMK014A-A</b>	128	0.08	174	0.06	94	0.12
<b>SMK014MA-A</b>	128	0.08	174	0.06	94	0.12
<b>SMK0A-□A</b>	128	0.08	174	0.06	94	0.12
<b>SMK237A-A</b>	98	0.18	140	0.13	70	0.25
<b>SMK216A-GN</b>	112	0.14	158	0.10	78	0.19
<b>SMK5100A-AA</b>	33	0.35	47	0.25	23	0.49
<b>SMK5160A-AA</b>	28	0.56	39	0.39	24	0.96
<b>SMK550A-GN</b>	54	0.22	77	0.16	39	0.31

● Enter the gear ratio in the box (□) within the model name.