

Stepping Motors

Stepping Motor and Driver Packages

DC Input

Introduction	AC Input Motor & Driver	DC Input Motor & Driver	Motor Only	Controllers	Accessories
	<ul style="list-style-type: none"> 0.36° /Geared <i>AS^{TEP}</i> AR 0.72° /Geared <i>AS^{TEP}</i> AS 0.9° /Geared <i>AS^{TEP}</i> RK 1.8° /Geared <i>AS^{TEP}</i> UMK 	<ul style="list-style-type: none"> 0.36° /Geared <i>AS^{TEP}</i> AR 0.36° /Geared <i>AS^{TEP}</i> ASX 0.36°/0.72° /Geared <i>AS^{TEP}</i> CRK 0.9°/1.8° /Geared <i>AS^{TEP}</i> CMK 1.8° /Geared <i>AS^{TEP}</i> RBK 	<ul style="list-style-type: none"> 0.36° <i>PK</i> 0.72° <i>PK</i> 0.9° <i>PK</i> 1.8° <i>PK/PV</i> Geared <i>PK</i> 	<ul style="list-style-type: none"> <i>SCX10</i> <i>EMP400</i> <i>5G8030J</i> 	<ul style="list-style-type: none"> Accessories
	<ul style="list-style-type: none"> 0.36° /Geared <i>AS^{TEP}</i> AR 	<p><i>AS^{TEP}</i> AR Series</p>			
	<ul style="list-style-type: none"> 0.36° /Geared <i>AS^{TEP}</i> ASX 	<p><i>AS^{TEP}</i>-One ASX Series</p>			
	<ul style="list-style-type: none"> 0.36°/0.72° /Geared <i>AS^{TEP}</i> CRK 	<p>CRK Series</p>			
	<ul style="list-style-type: none"> 0.9°/1.8° /Geared <i>AS^{TEP}</i> CMK 	<p>CMK Series</p>			
	<ul style="list-style-type: none"> 1.8° /Geared <i>AS^{TEP}</i> RBK 	<p>RBK Series</p>			

0.36° Closed Loop Stepping Motor and Driver Package α STEP High-Efficiency AR Series

● Connection information ●
 Technical reference → Page G-1
 Safety standards → Page H-2

This series substantially reduces heat generation from the motor through the use of high-efficiency technology. It allows you to take advantage of the beneficial features of the stepping motor to perform quick positioning operations over a short distance repeatedly without worrying about the duty cycle.



● For detailed product safety standard information including standards, file number and certification body, please visit www.orientalmotor.com.



Features

● Uses Oriental Motor's Original Closed Loop Control Technology

◇ Maintains Operation Even During Abrupt Load Fluctuations and Accelerations.

The **AR** Series uses our closed loop control to maintain positioning operation even during abrupt load fluctuations and accelerations.

The rotor position detection sensor monitors the rotation.

When an overload condition is detected, the **AR** Series will instantaneously regain control using the closed loop mode.

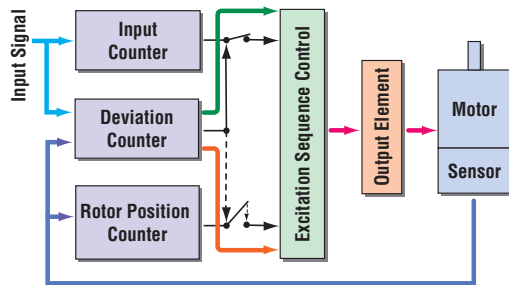

Normal (Positioning deviation is less than $\pm 1.8^\circ$)

Motor runs in open loop mode like a stepping motor.

During Overload Condition (Positioning deviation is $\pm 1.8^\circ$ or more)

The closed loop mode is engaged to maintain the positioning operation.

◇ Rotor Position Detection Sensor

The rotor position detection sensor uses the change in inductance caused by change in the distance between the stator teeth and the teeth on the sensor rotor to detect rotor position.

- This structure can be made small and thin, so the overall size of the motor can be reduced.
- High resolution
- This structure does not use electronic parts, so it is not affected by heat or vibration.

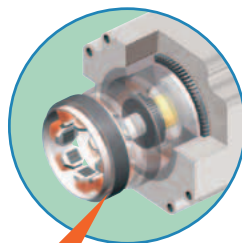

Sensor detects rotor position

● Alarm Signal Output in Case of Abnormality

If an overload is applied continuously, an alarm signal is output. When the positioning is complete, an END signal is output. This ensures the same level of reliability achieved by a servo motor.

● Maintaining All the Beneficial Features of a Stepping Motor

◇ High Response

The motor operates synchronously with pulse commands to achieve high response. There's no delay in operation following a pulse command.

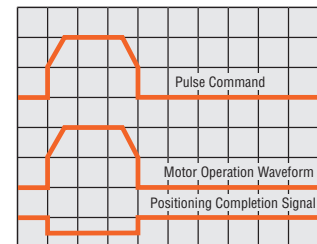

◇ No Tuning

With the **AR** Series, you can perform positioning quickly after a load change, etc., without adjusting any gains.

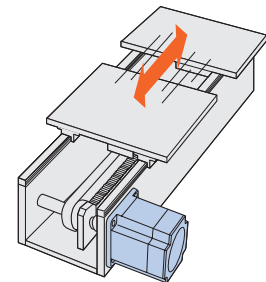

◇ No Hunting

Because it uses a stepping motor, the **AR** Series does not hunt when stopped. Accordingly, the **AR** Series is ideal for applications where the equipment uses a belt-drive mechanism or otherwise has low rigidity and you don't want it to vibrate when stopping.

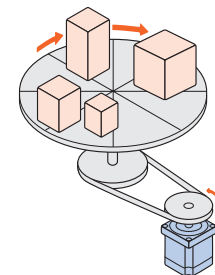

● Compact DC Input Driver with Plastic Case

The compact DC power input driver is covered by a plastic case. The compact size is great for space-saving. You can attach this driver to a 35 mm (1.38 in.) width DIN rail through one-step operation, no screw is needed. (DIN rail mounting is the only way to install the driver.)

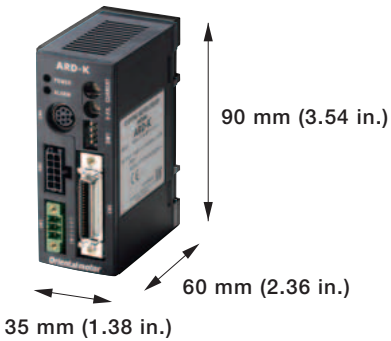

◇ Push Motion

The load is pressurized continuously. When contact is made with the load, pushing operation begins, and the pressurization can be carried out at a steady torque.

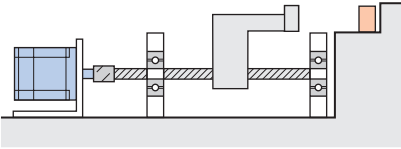

◇ 24/48 VDC

Choose the appropriate power supply 24 VDC or 48 VDC for your application. Motor torque at speed will be increased when 48 VDC is input rather than 24 VDC. [Only 24 VDC input is available for motor frame size 28 mm (1.10 in.) motors.]

AR66AK-3

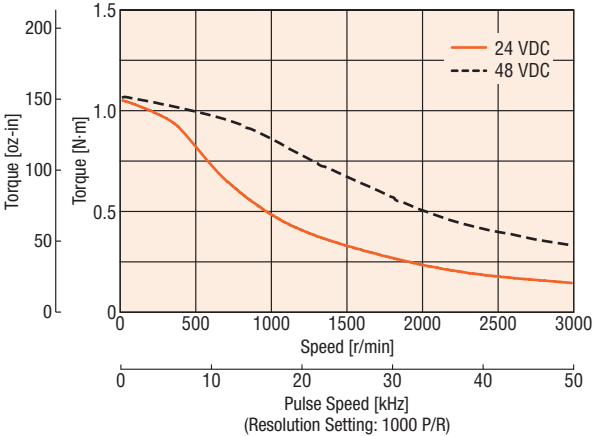

● Continuous Operation is Achieved Due to the Reduction of Motor Heat Generation by Utilizing High-Efficiency Technology

◇ Lower Heat Generation

The AR Series utilizes high-efficiency technology to achieve a significant reduction in the amount of heat generated from the motor.

● Temperature Distribution by Thermography

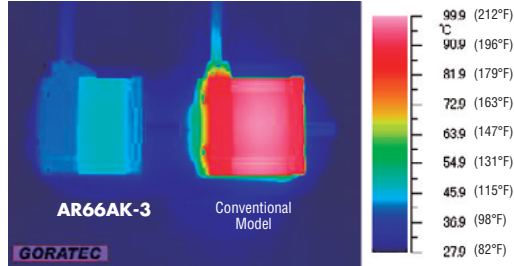

Comparison under the same conditions

● Motor Case Temperature under Same Operating Conditions

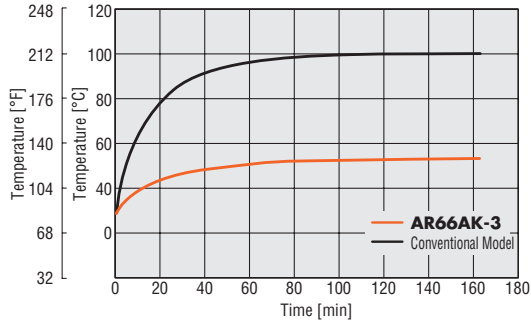

◇ Energy-Saving

Power consumption: up to **30%** less than a conventional model

● Power Consumption

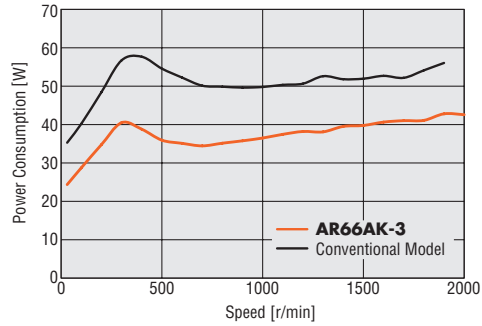

CO₂ emission: up to **30%** less* than a conventional model

*Assuming operation at a duty of 40%

◇ Continuous Operation or Operation at a high Duty Cycle

The AR Series can be operated at high frequency. You can drive the motor continuously.

Note



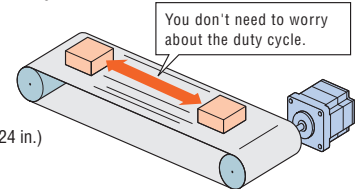

● If the motor is operated continuously, a heat sink of a capacity at least equivalent to an aluminum plate with a size of 100×100 mm (3.94×3.94 in.), 6 mm (0.24 in.) thick is required.



Introduction
AR66AK-3 / Geared / 0.36°
AR66AK-3 / Geared / 0.72°
AR66AK-3 / Geared / 1.8°
UMK / Geared / 0.9°/1.8°
DC Input Motor & Driver
AR66AK-3 / Geared / 0.36°
AR66AK-3 / Geared / 0.72°
ASX / Geared / 0.36°
CRK / Geared / 0.36°/0.72°
CMK / Geared / 0.9°/1.8°
RBK / Geared / 1.8°
PK / Geared / 0.36°
PK / Geared / 0.72°
PK / Geared / 0.9°
Motor Only
PK/PV / Geared / 1.8°
PK / Geared / 1.8°
Controllers
SCX10 / EMP400 / SG8030J
Accessories

AR Series Lineup

Characteristics Comparison for Motors and Geared Motors

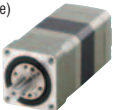
Motor Type Geared Type	Features	Permissible Torque Maximum Torque [N·m (lb-in)]	Backlash [arc min (degrees)]	Basic Resolution [deg/step]	Output Shaft Speed [r/min]
Step Angle 0.36° Standard Type 	<ul style="list-style-type: none"> Basic model of the AR Series 	Maximum Holding Torque 2 (17)	—	0.36	4000
TH Geared Type (Parallel shaft) 	<ul style="list-style-type: none"> High Speed (low gear ratio) A wide variety of gear ratios for selecting the desired step angle (resolution) Gear ratios: 3.6, 7.2, 10, 20, 30 	12 (106)	45 (0.75)	0.012	500
PS Geared Type (Planetary) 	<ul style="list-style-type: none"> High Speed (low gear ratio) High permissible/maximum torque A wide variety of gear ratios for selecting the desired step angle (resolution) Centered output shaft Gear ratios: 5, 7.2, 10, 25, 36, 50 	Permissible Torque 37 (320) 60 (530)	25 (0.42)	0.0072	600
PN Geared Type (Planetary) 	<ul style="list-style-type: none"> High speed (low gear ratio), high accuracy positioning High permissible/maximum torque A wide variety of gear ratios for selecting the desired step angle (resolution) Centered output shaft Gear ratios: 5, 7.2, 10, 25, 36, 50 	Permissible Torque 37 (320) 60 (530)	3 (0.05)	0.0072	600
Harmonic Geared Type (Harmonic drive) 	<ul style="list-style-type: none"> High accuracy positioning High permissible/maximum torque High resolution (high gear ratio) Centered output shaft Gear ratios: 50, 100 	Permissible Torque 37 (320) 55 (480)	0	0.0036	70

Note

The values shown above must be used as reference. These values vary depending on the frame size and gear ratio.

Range of Motor Frame Size

Four motor frame sizes are available.

[□42 (□1.65): indicates a motor frame size of 42 mm (1.65 in.).]

Motor Type		□28 (□1.10) □30 (□1.18)*1]	□42 (□1.65)	□60 (□2.36)	□85 (□3.35) □90 (□3.54)*2]
Step Angle 0.36° Standard Type	Without Electromagnetic Brake	●	●	●	●
	With Electromagnetic Brake		●	●	●
TH, PS, PN, Harmonic Geared Type	Without Electromagnetic Brake	●	●	●	●
	With Electromagnetic Brake		●	●	●

*1 Harmonic geared type

*2 Geared type

System Configuration

Standard Type with Electromagnetic Brake

An example of a single-axis system configuration with the **SG8030J** controller. * Not supplied

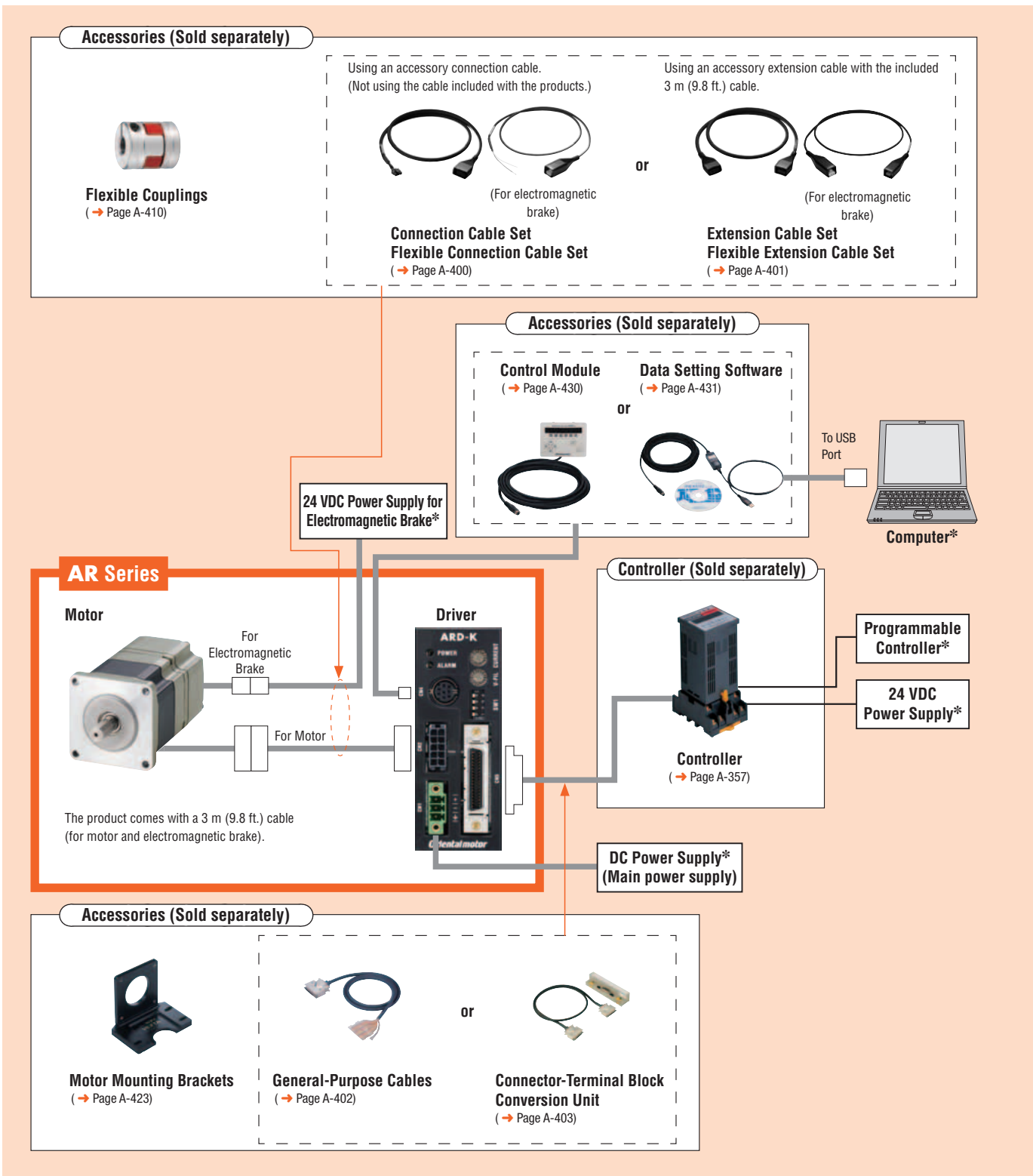

Example of System Configuration

AR Series	Sold Separately			
	Controller	Motor Mounting Bracket	Flexible Coupling	Connector-Terminal Block Conversion Unit [1 m (3.3 ft.)]
AR66MK-3	SG8030J-D	PAL2P5-A	MCS300610	CC36T1

The system configuration shown above is an example. Other combinations are available.

Introduction

AC Input Motor & Driver

- AR 0.36° / Geared
- AS 0.72° / Geared
- RK 0.9° / 1.8° / Geared
- UMK 0.36° / Geared

DC Input Motor & Driver

- AR 0.36° / Geared
- ASX 0.36° / Geared
- CRK 0.36° / 0.72° / Geared
- CMK 0.9° / 1.8° / Geared
- RBK 1.8° / Geared
- PK 0.36°
- PK 0.72°
- PK 0.9°
- PK/PV 1.8°
- PK Geared

Controllers

- SCX10
- EMP400
- SG8030J

Accessories

Product Number Code

AR 6 6 AK - PS 10 - 3

① ② ③ ④ ⑤ ⑥ ⑦ ⑧ ⑨

①	Series	AR: AR Series
②	Motor Frame Size	2: 28 mm (1.10 in.) [Geared type: 30 mm (1.18 in.)] 4: 42 mm (1.65 in.) 6: 60 mm (2.36 in.) 9: 85 mm (3.35 in.) [Geared type: 90 mm (3.54 in.)]
③	Motor Case Length	
④	Motor Classification	
⑤	Motor Type	A: Standard (Single shaft) B: Standard (Double shaft) M: Electromagnetic Brake Type

⑥	Power Supply Voltage	K: 24/48 VDC
⑦	Gearhead Type	Blank: Standard Type T: TH Geared Type PS: PS Geared Type N: PN Geared Type H: Harmonic Geared Type
⑧	Gear Ratio	
⑨	Cable Length (Included)	3: 3 m (9.8 ft.)

Product Line

Step Angle 0.36° Standard Type

Model (Single shaft)	Model (Double shaft)
AR24SAK-3	AR24SBK-3
AR26SAK-3	AR26SBK-3
AR46AK-3	AR46BK-3
AR66AK-3	AR66BK-3
AR69AK-3	AR69BK-3
AR98AK-3	AR98BK-3

TH Geared Type

TH Geared Type with Electromagnetic Brake

Model	Model
AR24SAK-T7.2-3	
AR24SAK-T10-3	
AR24SAK-T20-3	
AR24SAK-T30-3	
AR46AK-T3.6-3	AR46MK-T3.6-3
AR46AK-T7.2-3	AR46MK-T7.2-3
AR46AK-T10-3	AR46MK-T10-3
AR46AK-T20-3	AR46MK-T20-3
AR46AK-T30-3	AR46MK-T30-3
AR66AK-T3.6-3	AR66MK-T3.6-3
AR66AK-T7.2-3	AR66MK-T7.2-3
AR66AK-T10-3	AR66MK-T10-3
AR66AK-T20-3	AR66MK-T20-3
AR66AK-T30-3	AR66MK-T30-3
AR98AK-T3.6-3	AR98MK-T3.6-3
AR98AK-T7.2-3	AR98MK-T7.2-3
AR98AK-T10-3	AR98MK-T10-3
AR98AK-T20-3	AR98MK-T20-3
AR98AK-T30-3	AR98MK-T30-3

Step Angle 0.36° Standard Type with Electromagnetic Brake

Model
AR46MK-3
AR66MK-3
AR69MK-3
AR98MK-3

PS Geared Type

PS Geared Type with Electromagnetic Brake

Model	Model
AR24SAK-PS5-3	
AR24SAK-PS7-3	
AR24SAK-PS10-3	
AR46AK-PS5-3	AR46MK-PS5-3
AR46AK-PS7-3	AR46MK-PS7-3
AR46AK-PS10-3	AR46MK-PS10-3
AR46AK-PS25-3	AR46MK-PS25-3
AR46AK-PS36-3	AR46MK-PS36-3
AR46AK-PS50-3	AR46MK-PS50-3
AR66AK-PS5-3	AR66MK-PS5-3
AR66AK-PS7-3	AR66MK-PS7-3
AR66AK-PS10-3	AR66MK-PS10-3
AR66AK-PS25-3	AR66MK-PS25-3
AR66AK-PS36-3	AR66MK-PS36-3
AR66AK-PS50-3	AR66MK-PS50-3
AR98AK-PS5-3	AR98MK-PS5-3
AR98AK-PS7-3	AR98MK-PS7-3
AR98AK-PS10-3	AR98MK-PS10-3
AR98AK-PS25-3	AR98MK-PS25-3
AR98AK-PS36-3	AR98MK-PS36-3
AR98AK-PS50-3	AR98MK-PS50-3

The following items are included each product.

Motor, Driver, Cable for Motor, Cable for Electromagnetic Brake*, I/O Signal Connector, Connector for Power Supply Input/Frame Ground Terminal, Surge Suppressor*, Operating Manual, USER MANUAL (CD-ROM)

● Each product comes with cables for motor and electromagnetic brake 3 m (9.8 ft.) long.

If you need different length cable, or flexible cables, select an appropriate cable from among the accessories (sold separately). For details, refer to page A-400.

* Only with Electromagnetic Brake Type.

● **PN Geared Type**

Model	Model
AR24SAK-N5-3	
AR24SAK-N7.2-3	
AR24SAK-N10-3	
AR46AK-N5-3	AR46MK-N5-3
AR46AK-N7.2-3	AR46MK-N7.2-3
AR46AK-N10-3	AR46MK-N10-3
AR66AK-N5-3	AR66MK-N5-3
AR66AK-N7.2-3	AR66MK-N7.2-3
AR66AK-N10-3	AR66MK-N10-3
AR66AK-N25-3	AR66MK-N25-3
AR66AK-N36-3	AR66MK-N36-3
AR66AK-N50-3	AR66MK-N50-3
AR98AK-N5-3	AR98MK-N5-3
AR98AK-N7.2-3	AR98MK-N7.2-3
AR98AK-N10-3	AR98MK-N10-3
AR98AK-N25-3	AR98MK-N25-3
AR98AK-N36-3	AR98MK-N36-3
AR98AK-N50-3	AR98MK-N50-3

● **PN Geared Type with Electromagnetic Brake**

● **Harmonic Geared Type**

Model	Model
AR24SAK-H50-3	
AR24SAK-H100-3	
AR46AK-H50-3	AR46MK-H50-3
AR46AK-H100-3	AR46MK-H100-3
AR66AK-H50-3	AR66MK-H50-3
AR66AK-H100-3	AR66MK-H100-3
AR98AK-H50-3	AR98MK-H50-3
AR98AK-H100-3	AR98MK-H100-3

● **Harmonic Geared Type with Electromagnetic Brake**

Introduction	AC Input Motor & Driver	DC Input Motor & Driver	Motor Only	Controllers	Accessories
AR ^{OSTEP}	0.36° / Geared / AS	0.36° / Geared / ASX	0.36° / Geared / PK	SCX10 / EMP400 / 5G8030J	
AR	0.72° / Geared / RK	0.36°/0.72° / Geared / CRK	0.72° / Geared / PK		
UMK	0.9°/1.8° / Geared	0.9°/1.8° / Geared / CMK	0.9° / Geared / PK		
			1.8° / Geared / RBK		
			1.8° / Geared / PV		
			Geared / PK		

Step Angle 0.36° Motor Frame Size 28 mm (1.10 in.), 42 mm (1.65 in.), 60 mm (2.36 in.), 85 mm (3.35 in.)

Standard Type

Specifications RoHS



Model	Single Shaft	AR24SAK-3	AR26SAK-3	AR46AK-3	AR66AK-3	AR69AK-3	AR98AK-3
	Double Shaft	AR24SBK-3	AR26SBK-3	AR46BK-3	AR66BK-3	AR69BK-3	AR98BK-3
	Electromagnetic Brake	—	—	AR46MK-3	AR66MK-3	AR69MK-3	AR98MK-3
Maximum Holding Torque	N·m (oz·in)	0.055 (7.8)	0.12 (17.0)	0.3 (42)	1 (142)	2 (280)	
Holding Torque at Motor Standstill	Power ON	N·m (oz·in)	0.027 (3.8)	0.06 (8.5)	0.15 (21)	0.5 (71)	1 (142)
	Electromagnetic Brake	N·m (oz·in)	—	—	0.15 (21)	0.5 (71)	1 (142)
Rotor Inertia	J: kg·m ² (oz·in ²)	11×10 ⁻⁷ (0.060)	20×10 ⁻⁷ (0.109)	58×10 ⁻⁷ (0.32) [73×10 ⁻⁷ (0.4)]*1	380×10 ⁻⁷ (2.1) [500×10 ⁻⁷ (2.7)]*1	750×10 ⁻⁷ (4.1) [870×10 ⁻⁷ (4.8)]*1	1100×10 ⁻⁷ (6) [1220×10 ⁻⁷ (6.7)]*1
Resolution	Resolution Setting: 1000P/R	0.36°/Pulse					
Power Supply Input	Voltage	24 VDC ±10%		24 VDC ±10%/ 48 VDC ±5%	24 VDC ±10%/48 VDC ±5%*2		
	Maximum Input Current	A	0.9	1.4	3.1	3.0	2.5
Electromagnetic Brake*3	Power Supply Input	—		24 VDC ±5%*4 0.08A	24 VDC ±5%*4 0.25 A		

*1 The values inside the brackets [] represent the specification for the electromagnetic brake type.

*2 When running the motor at 48 VDC, the load inertia should be under 10 times of the rotor inertia and allow for a safety factor of 2 or more times the required torque.

*3 A separate power supply is required for the electromagnetic brakes.

*4 If the distance between the motor and driver is extended to 20 m (65.6 ft.) or longer, use a power supply of 24 VDC ±4%.

Speed-Torque Characteristics

AR24

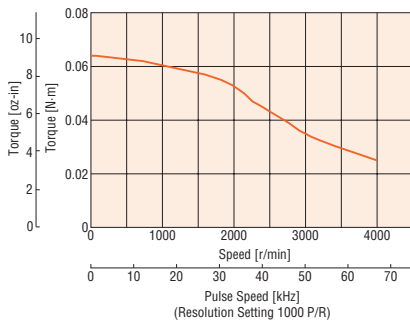

AR26

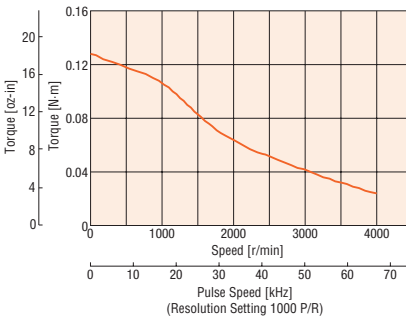

AR46

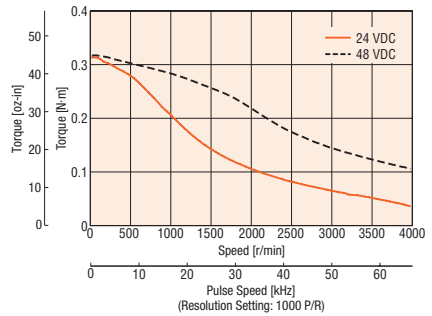

AR66

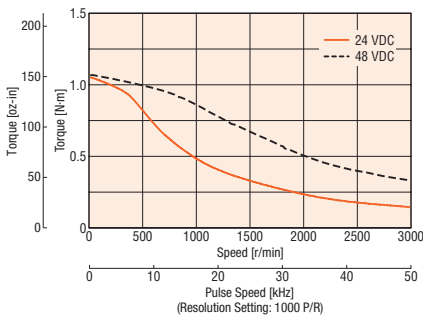

AR69

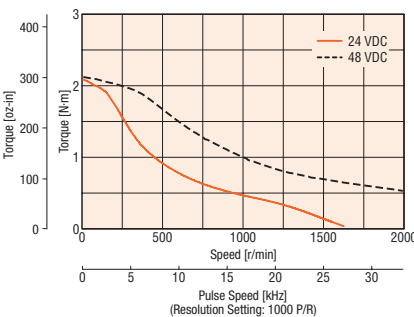

AR98

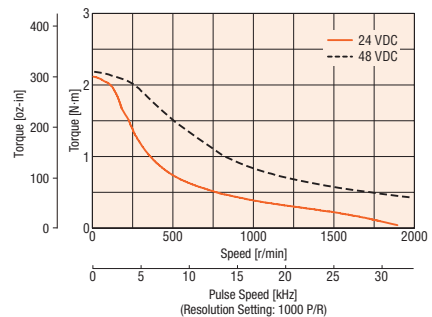

Note

● Pay attention to heat dissipation from the motor as there will be a considerable amount of heat under certain conditions. Be sure to keep the temperature of the motor case under 100°C (212°F).

TH Geared Type Motor Frame Size 28 mm (1.10 in.)

Specifications RoHS



Model		AR24SAK-T7.2-3	AR24SAK-T10-3	AR24SAK-T20-3	AR24SAK-T30-3
Maximum Holding Torque	N·m (oz·in)	0.2 (28)	0.3 (42)	0.4 (56)	0.5 (71)
Rotor Inertia	J: kg·m ² (oz·in ²)	11×10 ⁻⁷ (0.060)			
Gear Ratio		7.2	10	20	30
Resolution	Resolution Setting: 1000P/R	0.05°/Pulse	0.036°/Pulse	0.018°/Pulse	0.012°/Pulse
Permissible Torque	N·m (oz·in)	0.2 (28)	0.3 (42)	0.4 (56)	0.5 (71)
Holding Torque at Motor Standstill	Power ON N·m (oz·in)	0.13 (18.4)	0.19 (26)	0.38 (53)	0.5 (71)
Permissible Speed Range	r/min	0~416	0~300	0~150	0~100
Backlash	arc min (degrees)	60 (1)			
Power Supply Input	Voltage	24 VDC ± 10%			
	Maximum Input Current	A 0.9			

Speed-Torque Characteristics

AR24 Gear Ratio 7.2

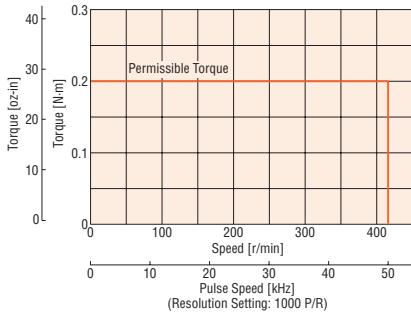

AR24 Gear Ratio 10

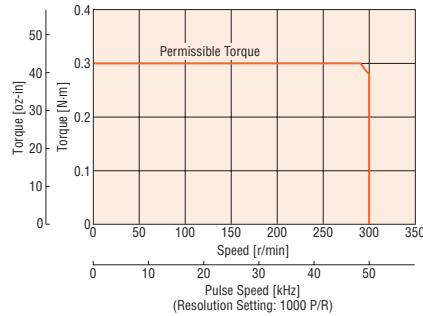

AR24 Gear Ratio 20

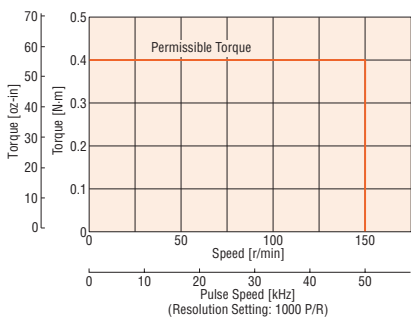

AR24 Gear Ratio 30

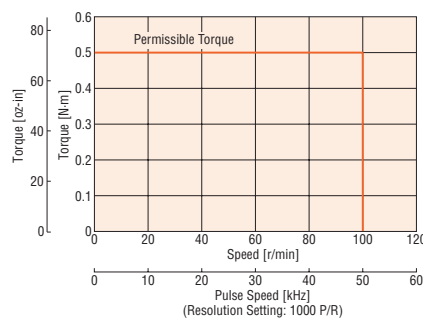

Note

● Pay attention to heat dissipation from the motor as there will be a considerable amount of heat under certain conditions. Be sure to keep the temperature of the motor case under 100°C (212°F).

Introduction	AR	0.36° / Geared	DC Input Motor & Driver
ASTEP	AR	0.36° / Geared	DC Input Motor & Driver
AS	ASX	0.36° / Geared	DC Input Motor & Driver
AS	CRK	0.36° / 0.72° / Geared	DC Input Motor & Driver
RK	CMK	0.9° / 1.8° / Geared	DC Input Motor & Driver
UMK	RBK	1.8° / Geared	DC Input Motor & Driver
	PK	0.36°	Motor Only
	PK	0.72°	Motor Only
	PK	0.9°	Motor Only
	PK/PV	1.8°	Motor Only
	PK	Geared	Motor Only
	SCX10 / EMP400 / SG8030J		Controllers
			Accessories

TH Geared Type Motor Frame Size 42 mm (1.65 in.)

Specifications RoHS



Model	Single Shaft	AR46AK-T3.6-3	AR46AK-T7.2-3	AR46AK-T10-3	AR46AK-T20-3	AR46AK-T30-3	
	Electromagnetic Brake	AR46MK-T3.6-3	AR46MK-T7.2-3	AR46MK-T10-3	AR46MK-T20-3	AR46MK-T30-3	
Maximum Holding Torque	N-m (lb-in)	0.35 (3.0)	0.7 (6.1)	1 (8.8)	1.5 (13.2)		
Rotor Inertia	J: kg·m ² (oz-in ²)	58×10 ⁻⁷ (0.32) [73×10 ⁻⁷ (0.4)]*1					
Gear Ratio		3.6	7.2	10	20	30	
Resolution		0.1°/Pulse	0.05°/Pulse	0.036°/Pulse	0.018°/Pulse	0.012°/Pulse	
Permissible Torque	N-m (lb-in)	0.35 (3.0)	0.7 (6.1)	1 (8.8)	1.5 (13.2)		
Holding Torque at Motor Standstill	Power ON	N-m (lb-in)	0.33 (2.9)	0.67 (5.9)	0.93 (8.2)	1.5 (13.2)	
	Electromagnetic Brake	N-m (lb-in)	0.33 (2.9)	0.67 (5.9)	0.93 (8.2)	1.5 (13.2)	
Permissible Speed Range	r/min	0~500	0~250	0~180	0~90	0~60	
Backlash	arc min (degrees)	45 (0.75)	25 (0.42)		15 (0.25)		
Power Supply Input	Voltage	24 VDC±10%/48 VDC±5%					
	Maximum Input Current	A	1.4				
Electromagnetic Brake*2	Power Supply Input	24 VDC±5%*3 0.08 A					

*1 The values inside the brackets [] represent the specification for the electromagnetic brake type.

*2 A separate power supply is required for the electromagnetic brakes.

*3 If the distance between the motor and driver is extended to 20 m (65.6 ft.) or longer, use a power supply of 24 VDC±4%.

Speed – Torque Characteristics

AR46 Gear Ratio 3.6

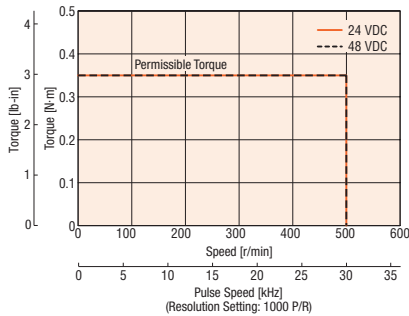

AR46 Gear Ratio 7.2

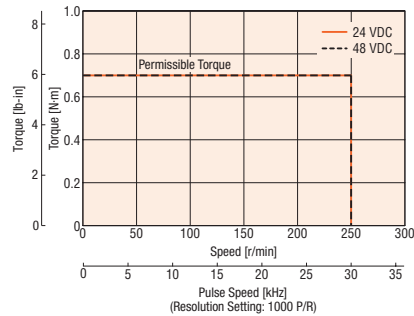

AR46 Gear Ratio 10

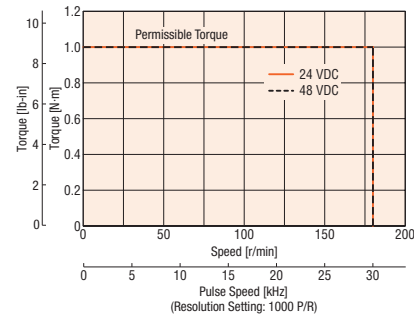

AR46 Gear Ratio 20

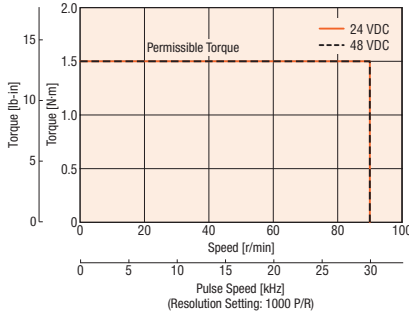

AR46 Gear Ratio 30

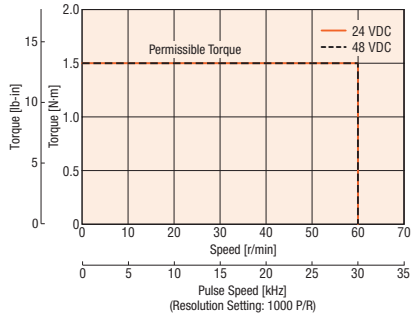

Note

● Pay attention to heat dissipation from the motor as there will be a considerable amount of heat under certain conditions. Be sure to keep the temperature of the motor case under 100°C (212°F).

TH Geared Type Motor Frame Size 60 mm (2.36 in.)

Specifications RoHS



Model	Single Shaft	AR66AK-T3.6-3	AR66AK-T7.2-3	AR66AK-T10-3	AR66AK-T20-3	AR66AK-T30-3	
	Electromagnetic Brake	AR66MK-T3.6-3	AR66MK-T7.2-3	AR66MK-T10-3	AR66MK-T20-3	AR66MK-T30-3	
Maximum Holding Torque	N-m (lb-in)	1.25 (11.0)	2.5 (22)	3 (26)	3.5 (30)	4 (35)	
Rotor Inertia	J: kg·m ² (oz·in ²)	380×10 ⁻⁷ (2.1) [500×10 ⁻⁷ (2.7)]*1					
Gear Ratio		3.6	7.2	10	20	30	
Resolution		0.1°/Pulse	0.05°/Pulse	0.036°/Pulse	0.018°/Pulse	0.012°/Pulse	
Permissible Torque	N-m (lb-in)	1.25 (11.0)	2.5 (22)	3 (26)	3.5 (30)	4 (35)	
Holding Torque at Motor Standstill	Power ON	N-m (lb-in)	1.1 (9.7)	2.2 (19.4)	3 (26)	3.5 (30)	4 (35)
	Electromagnetic Brake	N-m (lb-in)	1.1 (9.7)	2.2 (19.4)	3 (26)	3.5 (30)	4 (35)
Permissible Speed Range	r/min	0~500	0~250	0~180	0~90	0~60	
Backlash	arc min (degrees)	35 (0.59)	15 (0.25)		10 (0.17)		
Power Supply Input	Voltage	24 VDC±10%/48 VDC±5%*2					
	Maximum Input Current	A					
Electromagnetic Brake*3	Power Supply Input	24 VDC±5%*4 0.25 A					

- *1 The values inside the brackets [] represent the specification for the electromagnetic brake type.
- *2 When running the motor at 48 VDC, the load inertia should be under 10 times of the rotor inertia and allow for a safety factor of 2 or more times the required torque.
- *3 A separate power supply is required for the electromagnetic brakes.
- *4 If the distance between the motor and driver is extended to 20 m (65.6 ft.) or longer, use a power supply of 24 VDC±4%.

Speed – Torque Characteristics

AR66 Gear Ratio 3.6

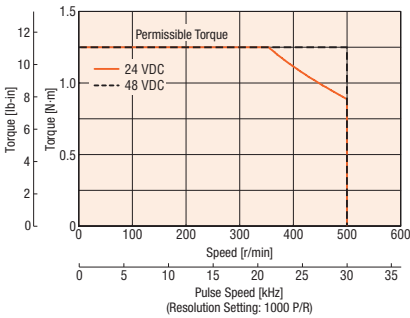

AR66 Gear Ratio 7.2

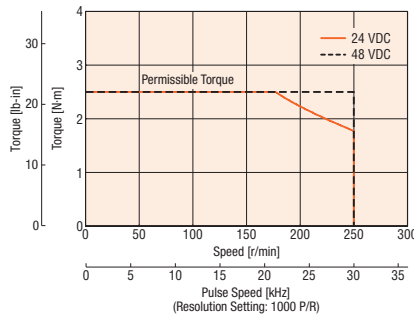

AR66 Gear Ratio 10

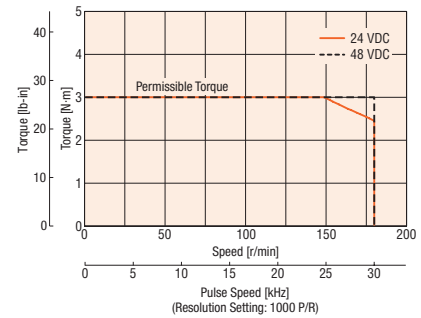

AR66 Gear Ratio 20

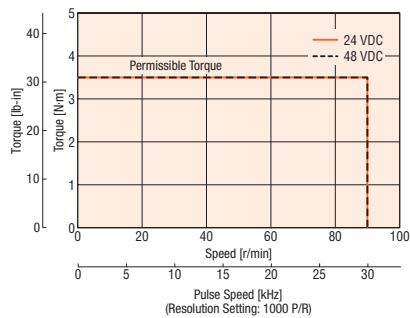

AR66 Gear Ratio 30

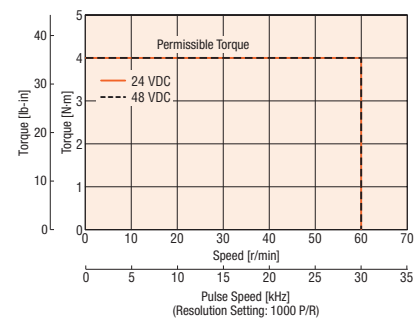

Note

- Pay attention to heat dissipation from the motor as there will be a considerable amount of heat under certain conditions. Be sure to keep the temperature of the motor case under 100°C (212°F).

Introduction
 AR 0.36° / Geared / ASTEP
 AR 0.72° / Geared / RK
 AR 0.9° / 1.8° / Geared / UMK
 AR 0.36° / Geared / ASTEP
 AR 0.36° / Geared / ASTEP
 AR 0.36° / 0.72° / Geared / CRK
 AR 0.9° / 1.8° / Geared / CMK
 AR 1.8° / Geared / RBK
 AR 0.36° / PK
 AR 0.72° / PK
 AR 0.9° / PK
 AR 1.8° / PK / PV
 AR Geared / PK
 Controllers / SCX10 / EMP400 / 5G8030J
 Accessories

TH Geared Type Motor Frame Size 90 mm (3.54 in.)

Specifications RoHS



Model	Single Shaft	AR98AK-T3.6-3	AR98AK-T7.2-3	AR98AK-T10-3	AR98AK-T20-3	AR98AK-T30-3
	Electromagnetic Brake	AR98MK-T3.6-3	AR98MK-T7.2-3	AR98MK-T10-3	AR98MK-T20-3	AR98MK-T30-3
Maximum Holding Torque	N-m (lb-in)	4.5 (39)	9 (79)		12 (106)	
Rotor Inertia	J: kg·m ² (oz-in ²)	1100×10 ⁻⁷ (6.0) [1220×10 ⁻⁷ (6.7)]*1				
Gear Ratio		3.6	7.2	10	20	30
Resolution		0.1°/Pulse	0.05°/Pulse	0.036°/Pulse	0.018°/Pulse	0.012°/Pulse
Permissible Torque	N-m (lb-in)	4.5 (39)	9 (79)		12 (106)	
Holding Torque at Motor Standstill	Power ON	N-m (lb-in)	3.6 (31)	7.2 (63)	9 (79)	12 (106)
	Electromagnetic Brake	N-m (lb-in)	3.6 (31)	7.2 (63)	9 (79)	12 (106)
Permissible Speed Range	r/min	0~500	0~250	0~180	0~90	0~60
Backlash	arc min (degrees)	25 (0.42)	15 (0.25)		10 (0.17)	
Power Supply Input	Voltage	24 VDC±10%/48 VDC±5%*2				
	Maximum Input Current	A				
Electromagnetic Brake*3	Power Supply Input	24 VDC±5%*4 0.25 A				

*1 The values inside the brackets [] represent the specification for the electromagnetic brake type.

*2 When running the motor at 48 VDC, the load inertia should be under 10 times of the rotor inertia and allow for a safety factor of 2 or more times the required torque.

*3 A separate power supply is required for the electromagnetic brakes.

*4 If the distance between the motor and driver is extended to 20 m (65.6 ft.) or longer, use a power supply of 24 VDC±4%.

Speed – Torque Characteristics

AR98 Gear Ratio 3.6

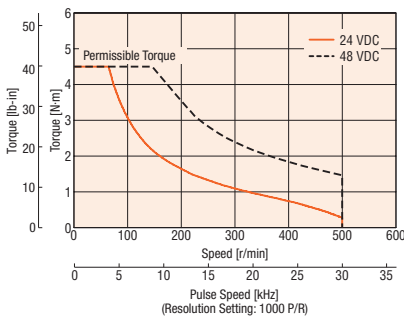

AR98 Gear Ratio 7.2

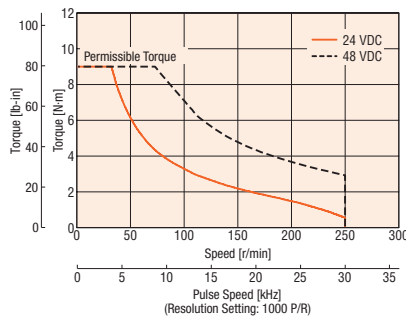

AR98 Gear Ratio 10

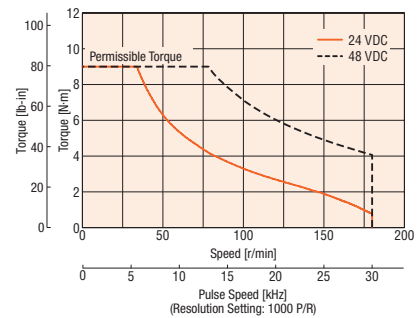

AR98 Gear Ratio 20

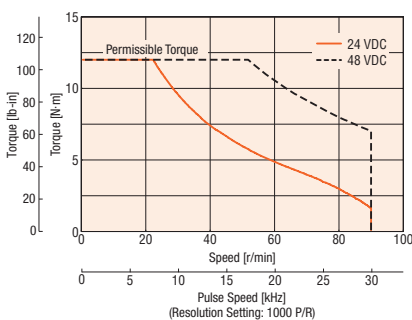

AR98 Gear Ratio 30

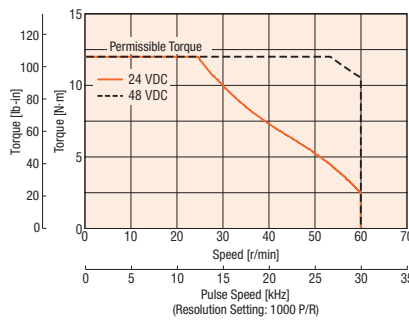

Note

● Pay attention to heat dissipation from the motor as there will be a considerable amount of heat under certain conditions. Be sure to keep the temperature of the motor case under 100°C (212°F).

PS Geared Type Motor Frame Size 28 mm (1.10 in.)

Specifications



Model		AR24SAK-PS5-3	AR24SAK-PS7-3	AR24SAK-PS10-3
Maximum Holding Torque	N·m (oz·in)	0.2 (28)	0.3 (42)	0.5 (71)
Rotor Inertia	J: kg·m ² (oz·in ²)	11×10 ⁻⁷ (0.060)		
Gear Ratio		5	7.2	10
Resolution	Resolution Setting: 1000P/R	0.072°/Pulse	0.05°/Pulse	0.036°/Pulse
Permissible Torque	N·m (oz·in)	0.2 (28)	0.3 (42)	0.5 (71)
Maximum Torque	N·m (oz·in)	0.5 (71)		
Holding Torque at Motor Standstill	Power ON N·m (oz·in)	0.13 (18.4)	0.19 (26)	0.27 (38)
Permissible Speed Range	r/min	0~600	0~416	0~300
Backlash	arc min (degrees)	35 (0.59)		
Power Supply Input	Voltage	24 VDC±10%		
	Maximum Input Current	A 0.9		

Speed – Torque Characteristics

AR24 Gear Ratio 5

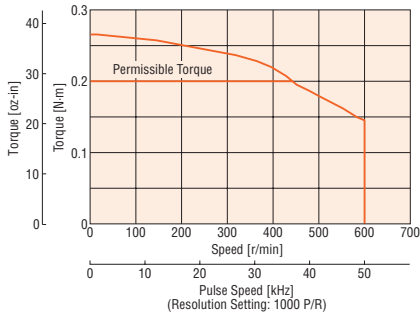

AR24 Gear Ratio 7.2

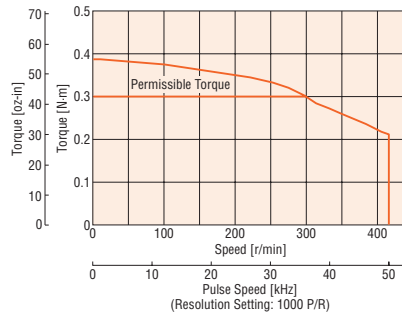

AR24 Gear Ratio 10

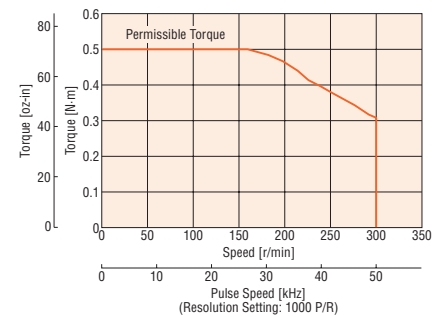

Note

- Pay attention to heat dissipation from the motor as there will be a considerable amount of heat under certain conditions. Be sure to keep the temperature of the motor case under 100°C (212°F).

Introduction	
AR ^{OSTEP} / Geared	0.36° / Geared
AS ^{OSTEP} / Geared	0.36° / Geared
RK / Geared	0.72° / Geared
UMK / Geared	0.9° / 1.8° / Geared
AR ^{OSTEP} / Geared	0.36° / Geared
ASX ^{OSTEP} / Geared	0.36° / Geared
CRK / Geared	0.36° / 0.72° / Geared
CMK / Geared	0.9° / 1.8° / Geared
RBK / Geared	1.8° / Geared
PK	0.36°
PK	0.72°
PK	0.9°
PK/PV	1.8°
PK	Geared
Controllers	SCX10 / EMP400 / SG8030J
Accessories	

PS Geared Type Motor Frame Size 42 mm (1.65 in.)

Specifications RoHS



Model	Single Shaft	AR46AK-PS5-3	AR46AK-PS7-3	AR46AK-PS10-3	AR46AK-PS25-3	AR46AK-PS36-3	AR46AK-PS50-3
	Electromagnetic Brake	AR46MK-PS5-3	AR46MK-PS7-3	AR46MK-PS10-3	AR46MK-PS25-3	AR46MK-PS36-3	AR46MK-PS50-3
Maximum Holding Torque	N-m (lb-in)	1 (8.8)	1.5 (13.2)	2.5 (22)	3 (26)		
Rotor Inertia	J: kg·m ² (oz-in ²)	58×10 ⁻⁷ (0.32) [73×10 ⁻⁷ (0.4)]*1					
Gear Ratio		5	7.2	10	25	36	50
Resolution	Resolution Setting:1000P/R	0.072°/Pulse	0.05°/Pulse	0.036°/Pulse	0.0144°/Pulse	0.01°/Pulse	0.0072°/Pulse
Permissible Torque	N-m (lb-in)	1 (8.8)	1.5 (13.2)	2.5 (22)	3 (26)		
Maximum Torque	N-m (lb-in)	1.5 (13.2)	2 (17.7)	3 (26)	6 (53)		
Holding Torque	Power ON	N-m (lb-in)	0.75 (6.6)	1 (8.8)	1.5 (13.2)	2.5 (22)	3 (26)
at Motor Standstill	Electromagnetic Brake	N-m (lb-in)	0.75 (6.6)	1 (8.8)	1.5 (13.2)	2.5 (22)	3 (26)
Permissible Speed Range	r/min	0~600	0~416	0~300	0~120	0~83	0~60
Backlash	arc min (degrees)	25 (0.42)					
Power Supply Input	Voltage	24 VDC ± 10% / 48 VDC ± 5%					
	Maximum Input Current	1.4					
Electromagnetic Brake*2	Power Supply Input	24 VDC ± 5%*3 0.08 A					

*1 The values inside the brackets [] represent the specification for the electromagnetic brake type.

*2 A separate power supply is required for the electromagnetic brakes.

*3 If the distance between the motor and driver is extended to 20 m (65.6 ft.) or longer, use a power supply of 24 VDC ± 4%.

Speed – Torque Characteristics

AR46 Gear Ratio 5

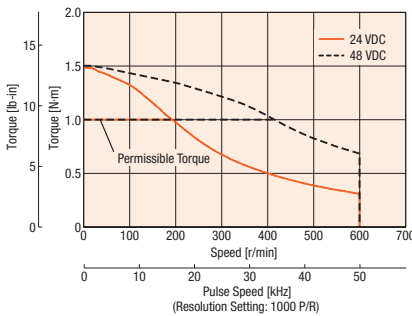

AR46 Gear Ratio 7.2

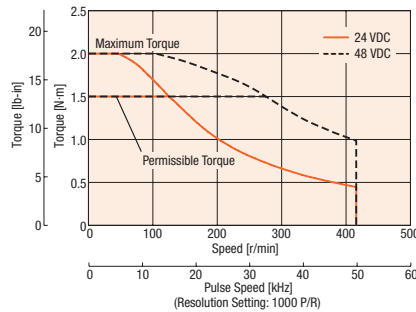

AR46 Gear Ratio 10

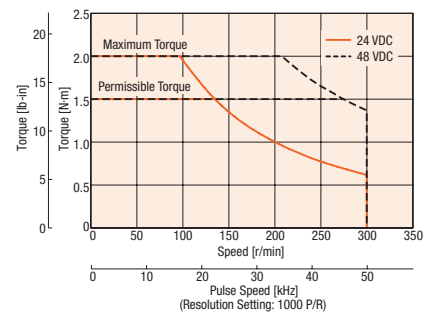

AR46 Gear Ratio 25

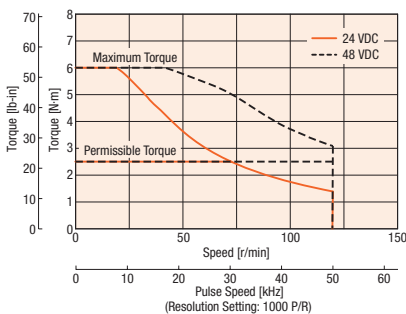

AR46 Gear Ratio 36

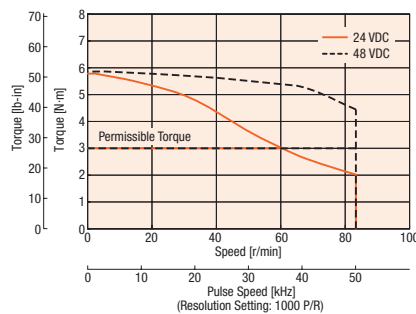

AR46 Gear Ratio 50

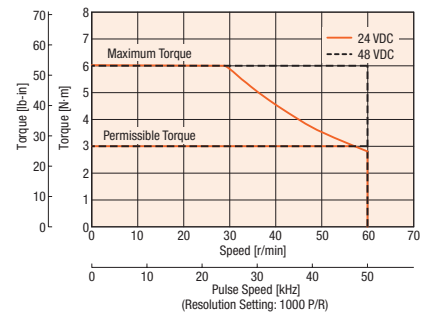

Note

● Pay attention to heat dissipation from the motor as there will be a considerable amount of heat under certain conditions. Be sure to keep the temperature of the motor case under 100°C (212°F).

PS Geared Type Motor Frame Size 90 mm (3.54 in.)

Specifications RoHS



Model	Single Shaft	AR98AK-PS5-3	AR98AK-PS7-3	AR98AK-PS10-3	AR98AK-PS25-3	AR98AK-PS36-3	AR98AK-PS50-3
	Electromagnetic Brake	AR98MK-PS5-3	AR98MK-PS7-3	AR98MK-PS10-3	AR98MK-PS25-3	AR98MK-PS36-3	AR98MK-PS50-3
Maximum Holding Torque	N-m (lb-in)	10 (88)	14 (123)	20 (177)	37 (320)		
Rotor Inertia	J: kg·m ² (oz-in ²)	1100×10 ⁻⁷ (6.0) [1220×10 ⁻⁷ (6.7)]*1					
Gear Ratio		5	7.2	10	25	36	50
Resolution	Resolution Setting:1000P/R	0.072°/Pulse	0.05°/Pulse	0.036°/Pulse	0.0144°/Pulse	0.01°/Pulse	0.0072°/Pulse
Permissible Torque	N-m (lb-in)	10 (88)	14 (123)	20 (177)	37 (320)		
Maximum Torque	N-m (lb-in)	28 (240)	35 (300)		56 (490)	60 (530)	
Holding Torque	Power ON N-m (lb-in)	5 (44)	7.2 (63)	10 (88)	25 (220)	36 (310)	37 (320)
at Motor Standstill	Electromagnetic Brake N-m (lb-in)	5 (44)	7.2 (63)	10 (88)	25 (220)	36 (310)	37 (320)
Permissible Speed Range	r/min	0~400	0~277	0~200	0~80	0~55	0~40
Backlash	arc min (degrees)	15 (0.25)					
Power Supply Input	Voltage	24 VDC±10%/48 VDC±5%*2					
	Maximum Input Current	A					
Electromagnetic Brake*3	Power Supply Input	24 VDC±5%*4 0.25A					

*1 The values inside the brackets [] represent the specification for the electromagnetic brake type.

*2 When running the motor at 48 VDC, the load inertia should be under 10 times of the rotor inertia and allow for a safety factor of 2 or more times the required torque.

*3 A separate power supply is required for the electromagnetic brakes.

*4 If the distance between the motor and driver is extended to 20 m (65.6 ft.) or longer, use a power supply of 24 VDC±4%.

Speed – Torque Characteristics

AR98 Gear Ratio 5

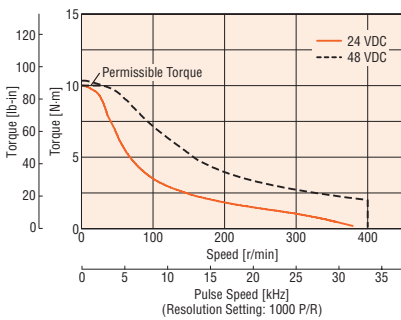

AR98 Gear Ratio 7.2

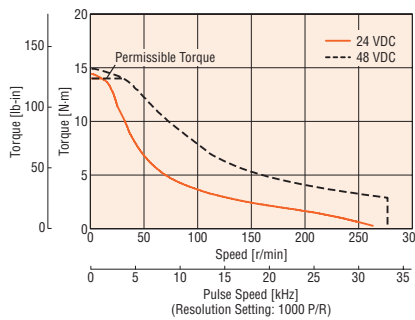

AR98 Gear Ratio 10

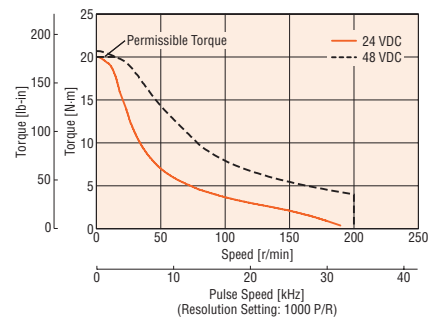

AR98 Gear Ratio 25

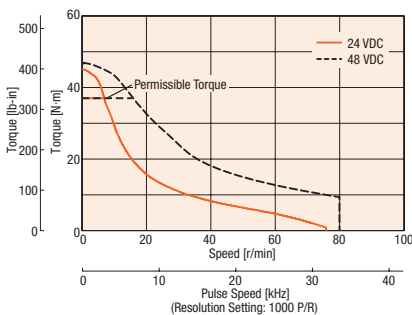

AR98 Gear Ratio 36

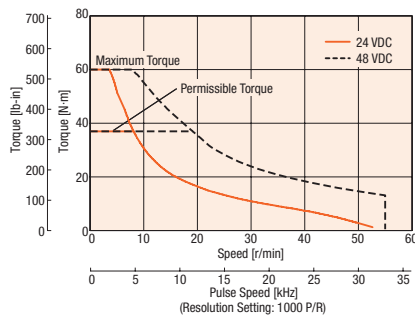

AR98 Gear Ratio 50

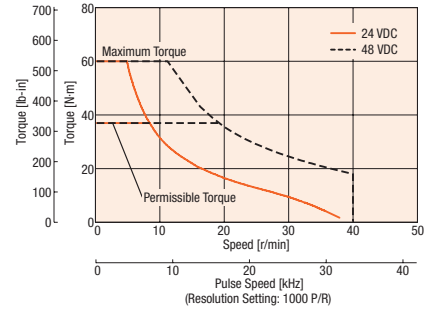

Note

● Pay attention to heat dissipation from the motor as there will be a considerable amount of heat under certain conditions. Be sure to keep the temperature of the motor case under 100°C (212°F).

PN Geared Type Motor Frame Size 28 mm (1.10 in.)

Specifications RoHS



Model		AR24SAK-N5-3	AR24SAK-N7.2-3	AR24SAK-N10-3
Maximum Holding Torque	N·m (oz·in)	0.2 (28)	0.3 (42)	0.5 (71)
Rotor Inertia	J: kg·m ² (oz·in ²)	11×10 ⁻⁷ (0.060)		
Gear Ratio		5	7.2	10
Resolution	Resolution Setting: 1000P/R	0.072°/Pulse	0.05°/Pulse	0.036°/Pulse
Permissible Torque	N·m (oz·in)	0.2 (28)	0.3 (42)	0.5 (71)
Maximum Torque	N·m (oz·in)	0.5 (71)		
Holding Torque at Motor Standstill	Power ON N·m (oz·in)	0.13 (18.4)	0.19 (26)	0.27 (38)
Permissible Speed Range	r/min	0~600	0~416	0~300
Backlash	arc min (degrees)	3 (0.05)		
Power Supply Input	Voltage	24 VDC±10%		
	Maximum Input Current	A 0.9		

Speed – Torque Characteristics

AR24 Gear Ratio 5

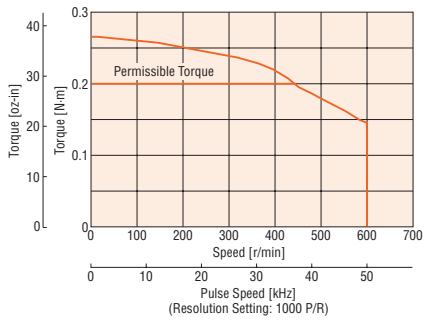

AR24 Gear Ratio 7.2

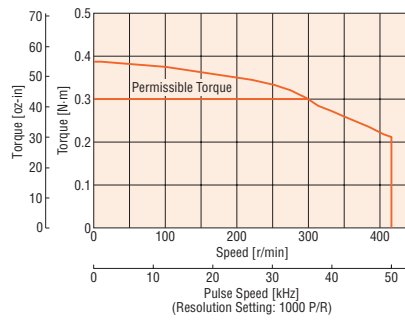

AR24 Gear Ratio 10

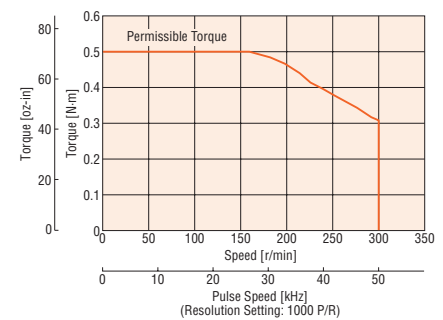

Note

- Pay attention to heat dissipation from the motor as there will be a considerable amount of heat under certain conditions. Be sure to keep the temperature of the motor case under 100°C (212°F).

Introduction
 AR 0.36° / Geared / Geared / Geared
 ASX 0.36° / Geared / Geared / Geared
 CRK 0.36° / Geared / Geared / Geared
 CMK 0.9° / Geared / Geared / Geared
 RBK 1.8° / Geared / Geared / Geared
 PK 0.36° / Geared / Geared / Geared
 PK 0.72° / Geared / Geared / Geared
 PK 0.9° / Geared / Geared / Geared
 PK/PV 1.8° / Geared / Geared / Geared
 PK Geared / Geared / Geared
 Controllers SCX10 / EMP400 / SG8030J
 Accessories

PN Geared Type Motor Frame Size 42 mm (1.65 in.)

Specifications RoHS



Model	Single Shaft	AR46AK-N5-3	AR46AK-N7.2-3	AR46AK-N10-3
	Electromagnetic Brake	AR46MK-N5-3	AR46MK-N7.2-3	AR46MK-N10-3
Maximum Holding Torque	N-m (lb-in)	1.35 (11.9)	1.5 (13.2)	
Rotor Inertia	J: kg·m ² (oz-in ²)	58×10 ⁻⁷ (0.32) [73×10 ⁻⁷ (0.4)]*1		
Gear Ratio		5	7.2	10
Resolution	Resolution Setting: 1000P/R	0.072°/Pulse	0.05°/Pulse	0.036°/Pulse
Permissible Torque	N-m (lb-in)	1.35 (11.9)	1.5 (13.2)	
Maximum Torque	N-m (lb-in)	1.5 (13.2)	2 (17.7)	
Holding Torque	Power ON	N-m (lb-in)	1 (8.8)	1.5 (13.2)
at Motor Standstill	Electromagnetic Brake	N-m (lb-in)	1 (8.8)	1.5 (13.2)
Permissible Speed Range	r/min	0~600	0~416	0~300
Backlash	arc min (degrees)	2 (0.034)		
Power Supply Input	Voltage	24 VDC±10%/48 VDC±5%		
	Maximum Input Current	A	1.4	
Electromagnetic Brake*2	Power Supply Input	24 VDC±5%*3 0.08 A		

*1 The values inside the brackets [] represent the specification for the electromagnetic brake type.

*2 A separate power supply is required for the electromagnetic brakes.

*3 If the distance between the motor and driver is extended to 20 m (65.6 ft.) or longer, use a power supply of 24 VDC±4%.

Speed – Torque Characteristics

AR46 Gear Ratio 5

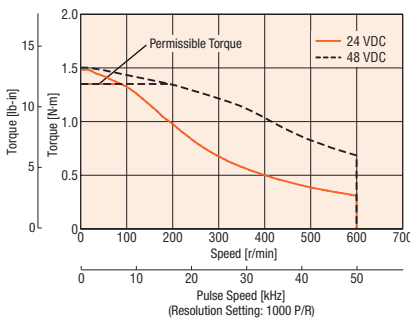

AR46 Gear Ratio 7.2

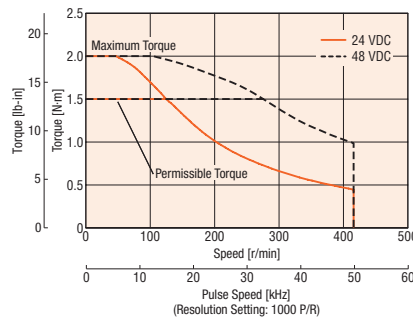

AR46 Gear Ratio 10

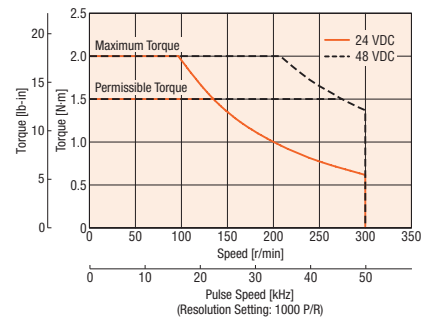

Note

● Pay attention to heat dissipation from the motor as there will be a considerable amount of heat under certain conditions. Be sure to keep the temperature of the motor case under 100°C (212°F).

PN Geared Type Motor Frame Size 60 mm (2.36 in.)

Specifications RoHS



Model	Single Shaft	AR66AK-N5-3	AR66AK-N7.2-3	AR66AK-N10-3	AR66AK-N25-3	AR66AK-N36-3	AR66AK-N50-3
	Electromagnetic Brake	AR66MK-N5-3	AR66MK-N7.2-3	AR66MK-N10-3	AR66MK-N25-3	AR66MK-N36-3	AR66MK-N50-3
Maximum Holding Torque	N-m (lb-in)	3.5 (30)	4 (35)	5 (44)	8 (70)		
Rotor Inertia	J: kg·m ² (oz·in ²)	380×10 ⁻⁷ (2.1) [500×10 ⁻⁷ (2.7)]*1					
Gear Ratio		5	7.2	10	25	36	50
Resolution	Resolution Setting: 1000P/R	0.072°/Pulse	0.05°/Pulse	0.036°/Pulse	0.0144°/Pulse	0.01°/Pulse	0.0072°/Pulse
Permissible Torque	N-m (lb-in)	3.5 (30)	4 (35)	5 (44)	8 (70)		
Maximum Torque	N-m (lb-in)	7 (61)	9 (79)	11 (97)	16 (141)	20 (177)	
Holding Torque	Power ON	2.5 (22)	3.6 (31)	5 (44)	7.6 (67)	8 (70)	
at Motor Standstill	Electromagnetic Brake	2.5 (22)	3.6 (31)	5 (44)	7.6 (67)	8 (70)	
Permissible Speed Range	r/min	0~600	0~416	0~300	0~120	0~83	0~60
Backlash	arc min (degrees)	2 (0.034)			3 (0.05)		
Power Supply Input	Voltage	24 VDC ± 10% / 48 VDC ± 5%*2					
	Maximum Input Current	3.1					
Electromagnetic Brake*3	Power Supply Input	24 VDC ± 5%*4 0.25 A					

*1 The values inside the brackets [] represent the specification for the electromagnetic brake type.

*2 When running the motor at 48 VDC, the load inertia should be under 10 times of the rotor inertia and allow for a safety factor of 2 or more times the required torque.

*3 A separate power supply is required for the electromagnetic brakes.

*4 If the distance between the motor and driver is extended to 20 m (65.6 ft.) or longer, use a power supply of 24 VDC ± 4%.

Speed – Torque Characteristics

AR66 Gear Ratio 5

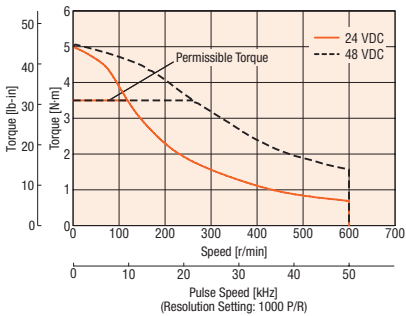

AR66 Gear Ratio 7.2

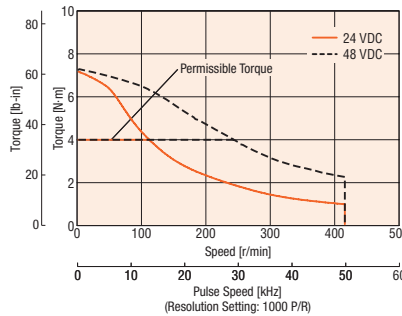

AR66 Gear Ratio 10

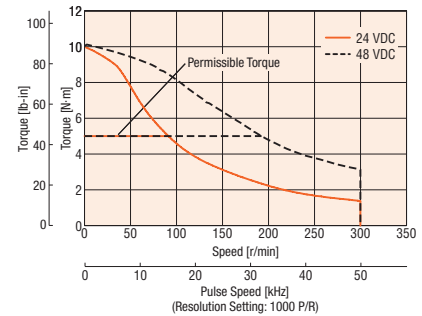

AR66 Gear Ratio 25

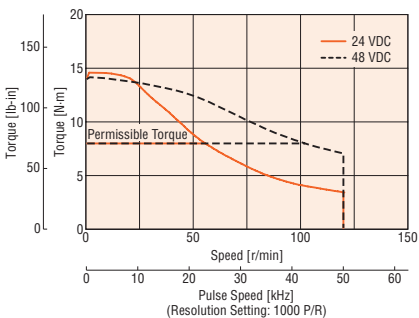

AR66 Gear Ratio 36

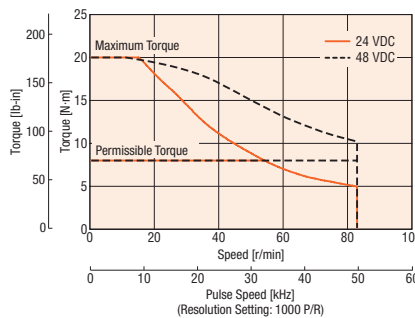

AR66 Gear Ratio 50

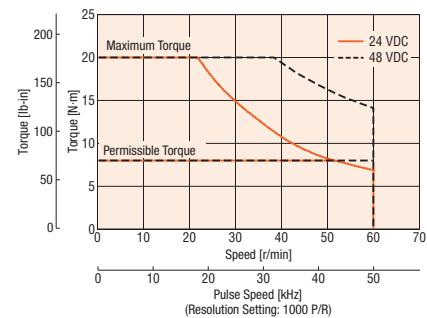

Note

● Pay attention to heat dissipation from the motor as there will be a considerable amount of heat under certain conditions. Be sure to keep the temperature of the motor case under 100°C (212°F).

Introduction
 AR *OSTEP* /Geared
 0.36°
 AC Input Motor & Driver
 AR *OSTEP* /AS
 0.72° /Geared
 RK
 0.9°/1.8° /Geared
 UMK
 AR *OSTEP* /Geared
 0.36° /Geared
 ASX
 DC Input Motor & Driver
 CRK
 0.36°/0.72° /Geared
 CMK
 0.9°/1.8° /Geared
 RBK
 1.8° /Geared
 PK
 0.36°
 PK
 0.72°
 PK
 0.9°
 PK
 1.8°
 PK/PV
 Geared
 PK
 Controllers
 SCX10
 /EMP400
 /SG8030J
 Accessories

PN Geared Type Motor Frame Size 90 mm (3.54 in.)

Specifications RoHS



Model	Single Shaft	AR98AK-N5-3	AR98AK-N7.2-3	AR98AK-N10-3	AR98AK-N25-3	AR98AK-N36-3	AR98AK-N50-3
	Electromagnetic Brake	AR98MK-N5-3	AR98MK-N7.2-3	AR98MK-N10-3	AR98MK-N25-3	AR98MK-N36-3	AR98MK-N50-3
Maximum Holding Torque	N-m (lb-in)	10 (88)	14 (123)	20 (177)	37 (320)		
Rotor Inertia	J: kg·m ² (oz-in ²)	1100×10 ⁻⁷ (6.0)			[1220×10 ⁻⁷ (6.7)]*1		
Gear Ratio		5	7.2	10	25	36	50
Resolution	Resolution Setting: 1000P/R	0.072°/Pulse	0.05°/Pulse	0.036°/Pulse	0.0144°/Pulse	0.01°/Pulse	0.0072°/Pulse
Permissible Torque	N-m (lb-in)	10 (88)	14 (123)	20 (177)	37 (320)		
Maximum Torque	N-m (lb-in)	28 (240)	35 (300)		56 (490)	60 (530)	
Holding Torque	Power ON N-m (lb-in)	5 (44)	7.2 (63)	10 (88)	25 (220)	36 (310)	37 (320)
at Motor Standstill	Electromagnetic Brake N-m (lb-in)	5 (44)	7.2 (63)	10 (88)	25 (220)	36 (310)	37 (320)
Permissible Speed Range	r/min	0~400	0~277	0~200	0~80	0~55	0~40
Backlash	arc min (degrees)	2 (0.034)			3 (0.05)		
Power Source	Voltage	24 VDC±10%/48 VDC±5%*2					
	Maximum Input Current	A					
Electromagnetic Brake*3	Power Supply Input	24 VDC±5%*4 0.25 A					

*1 The values inside the brackets [] represent the specification for the electromagnetic brake type.

*2 When running the motor at 48 VDC, the load inertia should be under 10 times of the rotor inertia and allow for a safety factor of 2 or more times the required torque.

*3 A separate power supply is required for the electromagnetic brakes.

*4 If the distance between the motor and driver is extended to 20 m (65.6 ft.) or longer, use a power supply of 24 VDC±4%.

Speed – Torque Characteristics

AR98 Gear Ratio 5

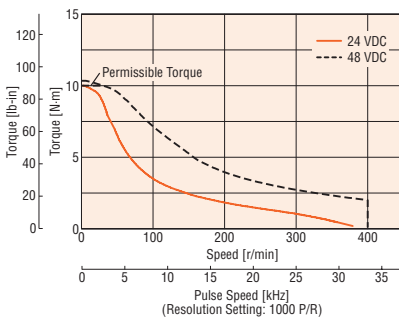

AR98 Gear Ratio 7.2

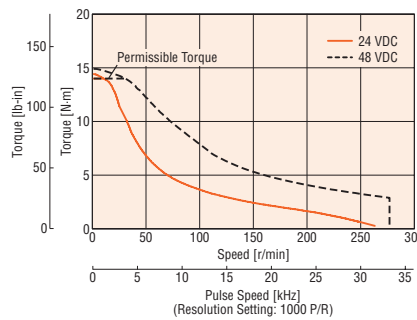

AR98 Gear Ratio 10

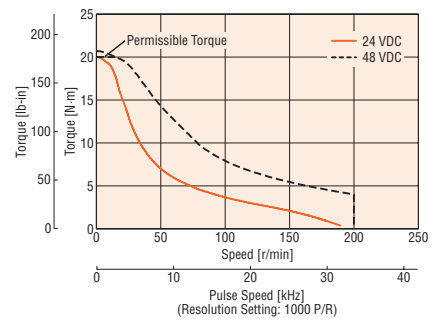

AR98 Gear Ratio 25

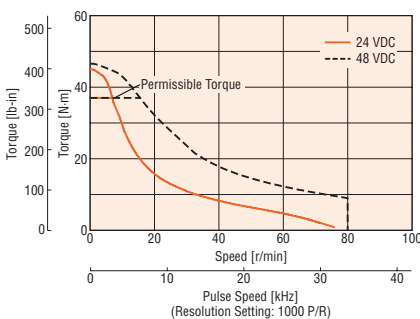

AR98 Gear Ratio 36

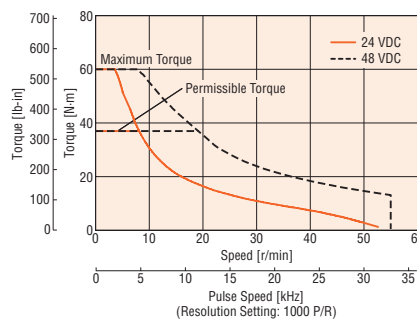

AR98 Gear Ratio 50

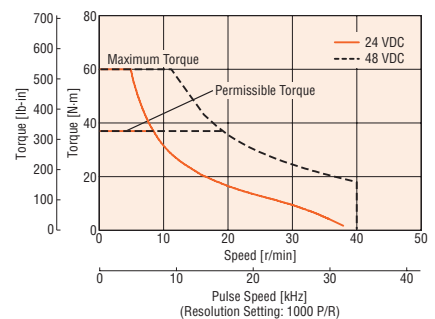

Note

● Pay attention to heat dissipation from the motor as there will be a considerable amount of heat under certain conditions. Be sure to keep the temperature of the motor case under 100°C (212°F).

Harmonic Geared Type Motor Frame Size 30 mm (1.18 in.), 42 mm (1.65 in.)

Specifications RoHS



Model	Single Shaft	AR24SAK-H50-3	AR24SAK-H100-3	AR46AK-H50-3	AR46AK-H100-3
	Electromagnetic Brake	—	—	AR46MK-H50-3	AR46MK-H100-3
Maximum Holding Torque	N·m (oz-in)	1.8 (250)	2.4 (340)	3.5 (30)	5 (44)
Rotor Inertia	J: kg·m ² (oz-in ²)	14×10 ⁻⁷ (0.077)		75×10 ⁻⁷ (0.41) [90×10 ⁻⁷ (0.49)]*1	
Gear Ratio		50	100	50	100
Resolution	Resolution Setting: 1000P/R	0.0072°/Pulse		0.0036°/Pulse	
Permissible Torque	N·m (oz-in)	1.8 (250)	2.4 (340)	3.5 (30)	5 (44)
Maximum Torque	N·m (oz-in)	3.3 (460)	4.8 (680)	8.3 (73)	11 (97)
Holding Torque at Motor Standstill	Power ON Electromagnetic Brake	N·m (oz-in) N·m (oz-in)	1.3 (184) —	2.4 (340) —	3.5 (30) 5 (44)
Lost Motion (Load Torque)	arc min	1.5 max (±0.09 N·m)	1.5 max (±0.12 N·m)	1.5 max (±0.16 N·m)	1.5 max (±0.2 N·m)
Permissible Speed Range	r/min	0~70	0~35	0~70	0~35
Power Supply Input	Voltage	24 VDC±10%		24 VDC±10%/48 VDC±5%	
	Maximum Input Current	A		1.4	
Electromagnetic Brake*2	Power Supply Input	—	—	24 VDC±5%*3 0.08A	

- *1 The values inside the brackets [] represent the specification for the electromagnetic brake type.
- *2 A separate power supply is required for the electromagnetic brakes.
- *3 If the distance between the motor and driver is extended to 20 m (65.6 ft.) or longer, use a power supply of 24 VDC±4%.

Note

- The inertia represents a sum of the inertia of the harmonic gear converted to a motor shaft value, and the rotor inertia.

Speed – Torque Characteristics

AR24 Gear Ratio 50

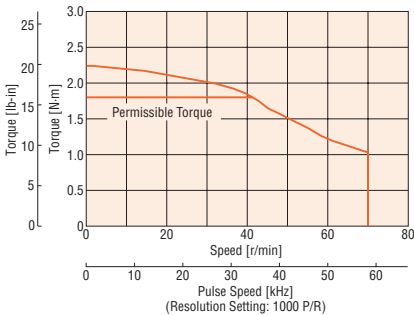

AR24 Gear Ratio 100

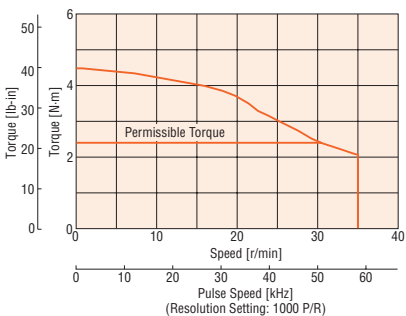

AR46 Gear Ratio 50

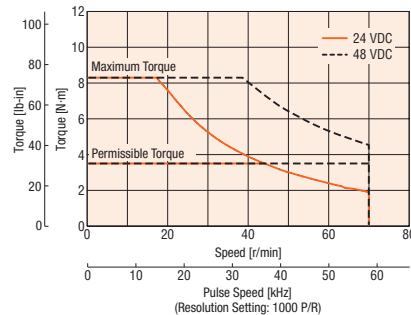

AR46 Gear Ratio 100

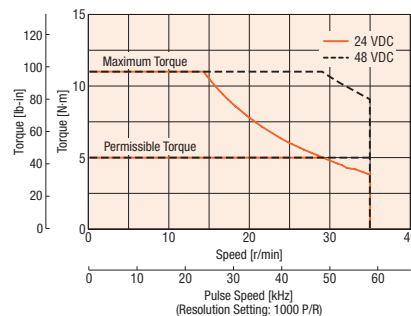

Notes

- Pay attention to heat dissipation from the motor as there will be a considerable amount of heat under certain conditions. Be sure to keep the temperature of the motor case under 100°C (212°F).
- In order to prevent fatigue of the gear grease in the harmonic gear, keep the temperature of the gear case under 70°C (158°F).

Introduction
AC Input Motor & Driver
Geared / Geared
0.36° / 0.72°
AR / AS
RK
UMK
0.9°/1.8° / Geared
0.36° / Geared
0.36° / Geared
ASX
DC Input Motor & Driver
0.36°/0.72° / Geared
CRK
CMK
RBK
1.8° / Geared
0.36°
PK
0.72°
PK
0.9°
PK
1.8°
PK/PV
Motor Only
Geared
PK
Controllers
SCX10
EMP400
/SG8030J
Accessories

Harmonic Geared Type Motor Frame Size 60 mm (2.36 in.), 90 mm (3.54 in.)

Specifications RoHS



Model	Single Shaft	AR66AK-H50-3	AR66AK-H100-3	AR98AK-H50-3	AR98AK-H100-3
	Electromagnetic Brake	AR66MK-H50-3	AR66MK-H100-3	AR98MK-H50-3	AR98MK-H100-3
Maximum Holding Torque	N·m (lb·in)	5.5 (48)	8 (70)	25 (220)	37 (320)
Rotor Inertia	J: kg·m ² (oz·in ²)	415×10 ⁻⁷ (2.3)	535×10 ⁻⁷ (2.9) ^{*1}	1300×10 ⁻⁷ (7.1)	1420×10 ⁻⁷ (7.8) ^{*1}
Gear Ratio		50	100	50	100
Resolution	Resolution Setting: 1000P/R	0.0072°/Pulse	0.0036°/Pulse	0.0072°/Pulse	0.0036°/Pulse
Permissible Torque	N·m (lb·in)	5.5 (48)	8 (70)	25 (220)	37 (320)
Maximum Torque	N·m (lb·in)	18 (159)	28 (240)	35 (300)	55 (480)
Holding Torque at Motor Standstill	Power ON	N·m (lb·in)	8 (70)	25 (220)	37 (320)
	Electromagnetic Brake	N·m (lb·in)	5.5 (48)	8 (70)	25 (220)
Lost Motion (Load Torque)	arc min	0.7 max (±0.28 N·m)	0.7 max (±0.39 N·m)	1.5 max (±1.2 N·m)	
Permissible Speed Range	r/min	0~60	0~30	0~40	0~20
Power Supply Input	Voltage	24 VDC±10%/48 VDC±5% ^{*2}			
	Maximum Input Current	A	3.1		2.5
Electromagnetic Brake ^{*3}	Power Supply Input	24 VDC±5% ^{*4} 0.25 A			

*1 The values inside the brackets [] represent the specification for the electromagnetic brake type.

*2 When running the motor at 48 VDC, the load inertia should be under 10 times of the rotor inertia and allow for a safety factor of 2 or more times the required torque.

*3 A separate power supply is required for the electromagnetic brakes.

*4 If the distance between the motor and driver is extended to 20 m (65.6 ft.) or longer, use a power supply of 24 VDC±4%.

Note

● The inertia represents a sum of the inertia of the harmonic gear converted to a motor shaft value, and the rotor inertia.

Speed – Torque Characteristics

AR66 Gear Ratio 50

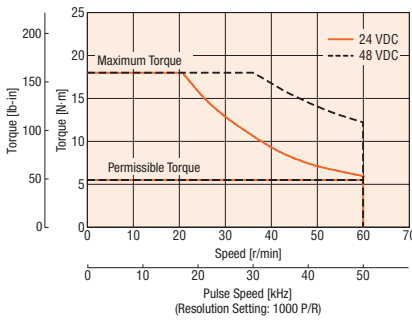

AR98 Gear Ratio 50

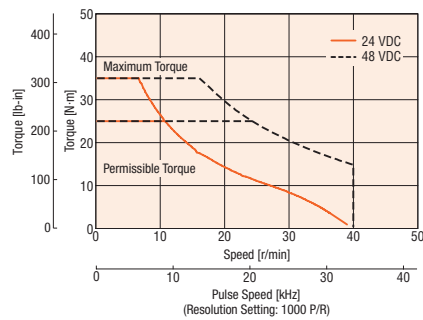

AR66 Gear Ratio 100

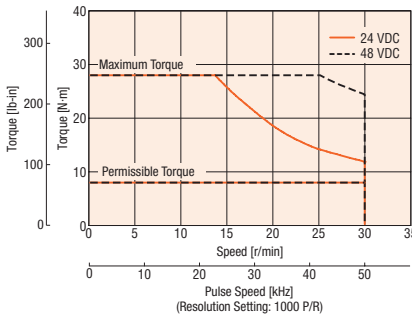

AR98 Gear Ratio 100

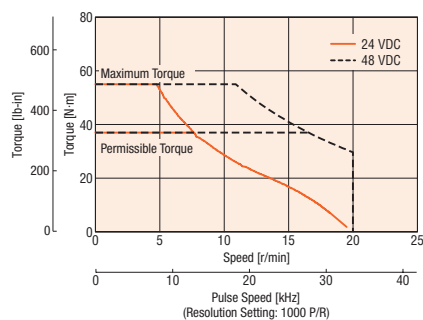

Notes

- Pay attention to heat dissipation from the motor as there will be a considerable amount of heat under certain conditions. Be sure to keep the temperature of the motor case under 100°C (212°F).
- In order to prevent fatigue of the gear grease in the harmonic gear, keep the temperature of the gear case under 70°C (158°F).

Driver Specifications

Speed and Positioning Control Command	Pulse input
Maximum Input Pulse Frequency	When the host controller is a line driver output: 500 kHz (When the pulse duty is 50%) When the host controller is an open-collector output: 250 kHz (When the pulse duty is 50%)*
Protective Functions	When the following protective functions are activated, an alarm signal is output and the motor will coast to a stop. Overheat, Overload, Overspeed, Command pulse error, Overvoltage, Undervoltage, Overflow rotation during current on, Overflow rotation during current off, Abnormal operation data, Electronic gear setting error, Sensor error during operation, Initial sensor error, Initial rotor rotation error, Motor combination error, EEPROM error
Input Signals	Photocoupler input, Input resistance: 3 kΩ, Input signal voltage: 4.75 to 26.4 V (C-ON, FREE, CS, RETURN, P-RESET, CLR/ALM-RST, CCM, MO, M1, M2) Photocoupler input, Input resistance: 200 Ω, Input signal voltage: 3 to 5.25 V (CW/PLS, CCW/DIR) Photocoupler input, Input resistance: 2.7 kΩ, Input signal voltage: 21.6 to 26.4 V (CW24V/PLS24V, CCW24V/DIR24V)
Output Signals	Photocoupler, Open-collector output External use condition: 30 VDC maximum, 10 mA maximum (READY, TLC, END, TIM2, WNG, ALM) Line driver output External use condition: Connect a terminal resistor of 100 Ω or more between the driver and the input of the line receiver. (TIM1, ASG, BSG)
Other Functions	<ul style="list-style-type: none"> Motor resolution setting function (4 levels) Current setting function (16 levels) Velocity filter function (16 levels) Pulse input setting function (2-pulse input, 1-pulse input) Current control mode function
Extended Functions [When the control module (OPX-2A) or data setting software (MEXE02) (both sold separately) is used]	<ul style="list-style-type: none"> Push-motion operation function (8 current levels; desired levels can be set within a range of 0 to 100%) Motor resolution setting function (electronic gear) Alarm code output function (3 bits) Current setting function (16 levels; desired levels can be set within a range of 0 to 100%) Velocity filter function (16 levels; desired levels can be set within a range of 0 to 200 ms) Current ON (C-ON) input logic setting function Positioning completion (END) signal width setting function Positioning completion (END) signal offset setting function Standstill current setting function Return operation setting function (starting speed, acceleration/deceleration rate, operating speed) JOG operation setting function (starting speed, acceleration/deceleration rate, operating speed) OPX-2A display setting function (gear output shaft speed, speed code display, setting change prohibition) Pulse input setting function (2-pulse, 1-pulse, logic, phase difference, multiplication) Smooth drive cancellation Motor excitation position setting function at power ON Excitation position reset operation function at current ON Motor rotation direction setting function Warning output setting function (overflow rotation during current on, overflow rotation during current off, overheat, overvoltage, undervoltage, overload, overspeed, abnormal operation data, electronic gear setting error)

*Value applies when an accessory general-purpose cable (**CC36D1-1**) is used. General-purpose cable → Page A-402

General Specifications

Item	Motor	Driver
Thermal Class	130 (B)	—
Insulation Resistance	100 MΩ or more when 500 VDC megger is applied between the following places: • Case – Motor and sensor windings • Case – Electromagnetic brake windings	—
Dielectric Strength	Sufficient to withstand the following for 1 minute: • Case – Motor and sensor windings 1.0 kVAC 50 Hz or 60 Hz • Case – Electromagnetic brake windings 1.0 kVAC 50 Hz or 60 Hz	—
Operating Environment	Ambient Temperature	−10~+50°C (+14~+122°F) (non-freezing)*1: Step Angle 0.36° Standard type, TH, PS, PN geared type 0~+40°C (+32~+104°F) (non-freezing)*1: Harmonic geared type
	Ambient Humidity	85% or less (non-condensing)
	Atmosphere	No corrosive gases, dust, water or oil
Degree of Protection	IP54 (Double shaft type, AR24 and AR26 : IP20)*2	IP20
Stop Position Accuracy	AR24, AR26, AR46 : ±4 arc minutes (±0.067°) AR66, AR69, AR98 : ±3 arc minutes (±0.05°)	
Shaft Runout	0.05 mm (0.002 in) T.I.R.*3	—
Concentricity	0.075 mm (0.003 in) T.I.R.*3	—
Perpendicularity	0.075 mm (0.003 in) T.I.R.*3	—

*1 When a heat sink of a capacity at least equivalent to an aluminum plate with a size of 100×100 mm (3.94×3.94 in), 6 mm (0.24 in.) thick is installed.

*2 Excluding the mounting surface and connector

*3 T.I.R. (Total Indicator Reading): The total dial gauge reading when the measurement section is rotated one revolution centered on the reference axis center.

Note

● Do not measure insulation resistance or perform the dielectric strength test while the motor and driver are connected.

Permissible Overhung Load and Permissible Thrust Load

→ Page A-14

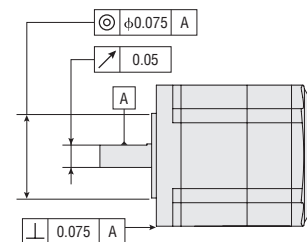

Introduction
AC Input Motor & Driver
0.36° / Geared
0.72° / Geared
0.9° / 1.8° / Geared
UMK
DC Input Motor & Driver
0.36° / Geared
0.36° / Geared
ASX
0.36° / 0.72° / Geared
CRK
0.9° / 1.8° / Geared
CMK
1.8° / Geared
RBK
0.36° / PK
0.72° / PK
Motor Only
0.9° / PK
1.8° / PK/PV
Geared / PK
Controllers
SCX10 / EMP400 / 5G80301
Accessories

Load Torque – Driver Input Current Characteristics

This is the relationship between the load torque and driver input current at each speed when the motor is operated. From these characteristics, the current capacity required when used for multiple axes can be estimated. For geared motors, convert to torque and speed at the motor shaft.

$$\text{Motor shaft speed [r/min]} = \text{Gear output shaft speed} \times \text{Gear ratio}$$

$$\text{Motor shaft torque [N}\cdot\text{m (oz}\cdot\text{in)}] = \frac{\text{Gear output shaft torque}}{\text{Gear ratio}}$$

● 24 VDC

AR24

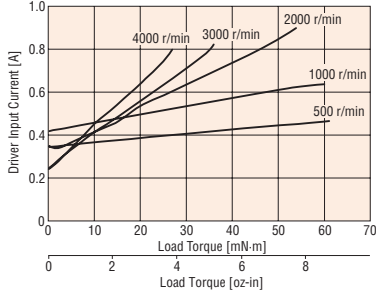

AR26

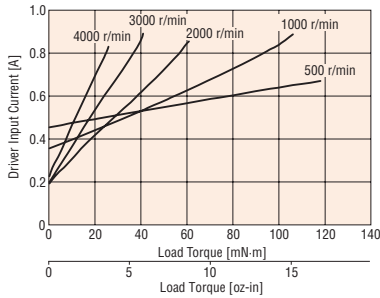

AR46

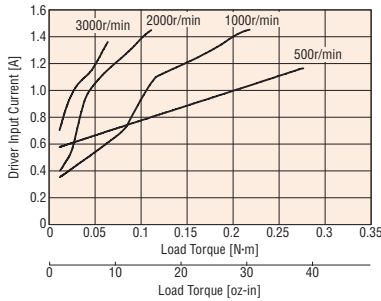

AR66

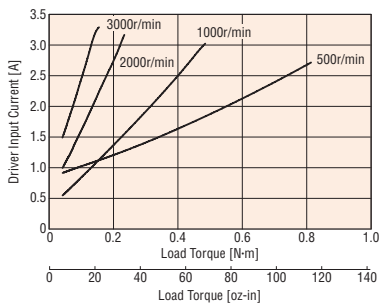

AR69

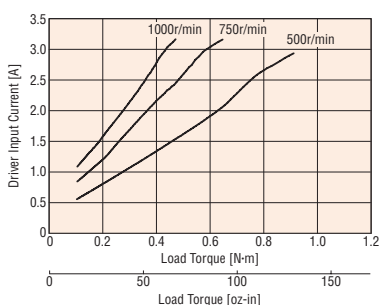

AR98

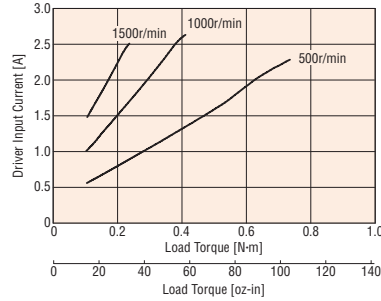

● 48 VDC

AR46

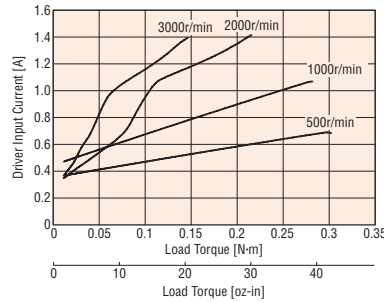

AR66

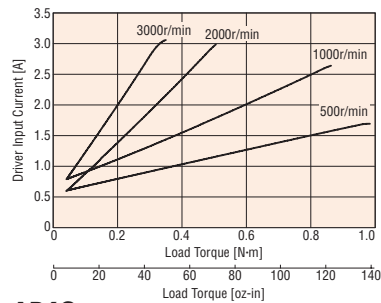

AR69

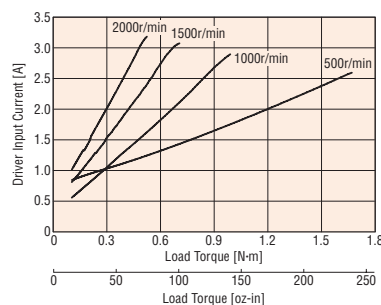

AR98

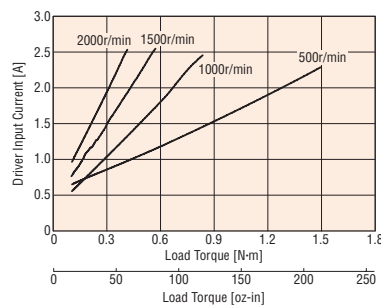

Dimensions Unit = mm (in.)

Motor

◇ Step Angle 0.36° Standard Type

Motor Frame Size 28 mm (1.10 in.)

Model	Motor Model	L1	L2	Mass kg (lb.)	DXF
AR24SAK-3	ARM24SAK	45 (1.77)	—	0.15 (5.3)	B705
AR24SBK-3	ARM24SBK	56 (2.20)	—		
AR26SAK-3	ARM26SAK	65 (2.56)	—	0.22 (7.8)	B706
AR26SBK-3	ARM26SBK	76 (2.99)	—		

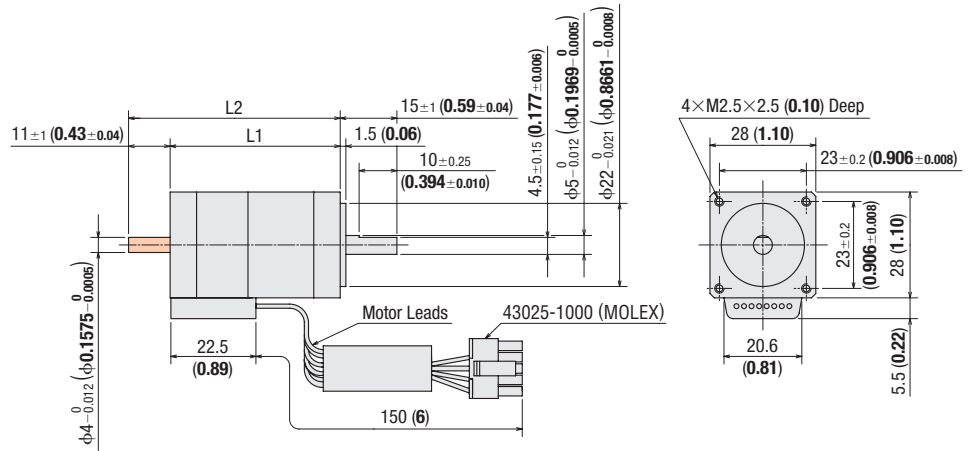

Motor Frame Size 42 mm (1.65 in.)

Model	Motor Model	Mass kg (lb.)	DXF
AR46AK-3	ARM46AK	0.47 (1.03)	B516
AR46BK-3	ARM46BK		

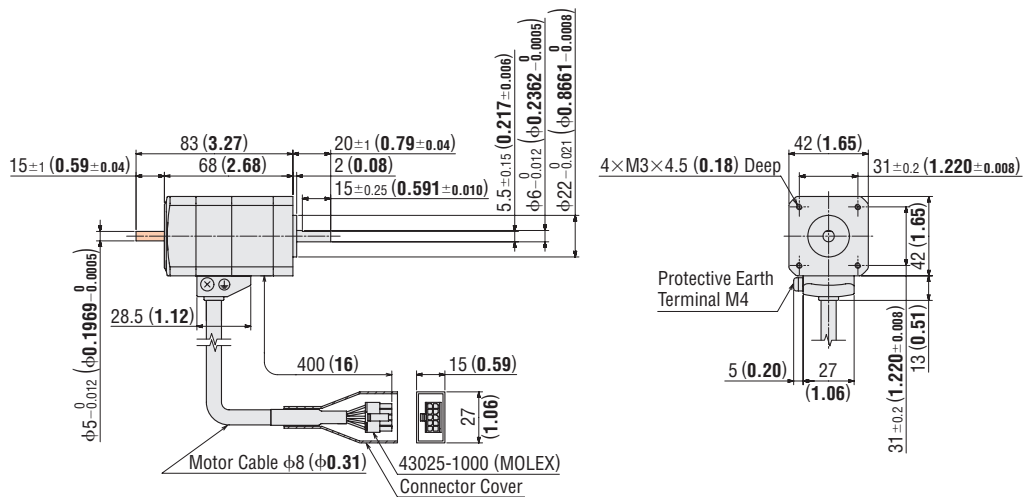

● These dimensions are for double shaft models. For single shaft models, ignore the shaded areas.

Introduction	AC Input Motor & Driver	DC Input Motor & Driver	Motor Only	Controllers	Accessories
AR	0.36° / Geared	0.36° / Geared	0.36° / Geared	SCX10	
AS	0.72° / Geared	0.36° / Geared	0.72° / Geared	EMP400	
ASX	0.36° / Geared	0.36° / Geared	0.9° / Geared	5G8030J	
CRK	0.36° / Geared	0.36° / Geared	1.8° / Geared		
CMK	0.36° / Geared	0.36° / Geared	1.8° / Geared		
RBK	0.36° / Geared	0.36° / Geared	1.8° / Geared		
PK	0.36° / Geared	0.36° / Geared	1.8° / Geared		
PK	0.72° / Geared	0.36° / Geared	1.8° / Geared		
PK	0.9° / Geared	0.36° / Geared	1.8° / Geared		
PK/PV	0.36° / Geared	0.36° / Geared	1.8° / Geared		
PK	0.36° / Geared	0.36° / Geared	1.8° / Geared		

Motor Frame Size 60 mm (2.36 in.)

Model	Motor Model	L1	L2	Mass kg (lb.)	DXF
AR66AK-3	ARM66AK	64.5 (2.54)	-	0.9 (1.98)	B517
AR66BK-3	ARM66BK		85.5 (3.37)		
AR69AK-3	ARM69AK	90 (3.54)	-	1.4 (3.1)	B518
AR69BK-3	ARM69BK		111 (4.37)		

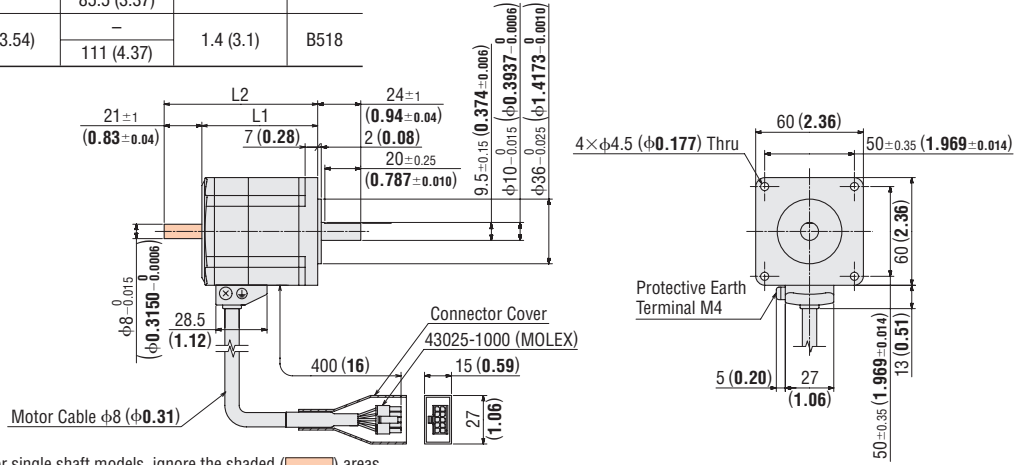

● These dimensions are for double shaft models. For single shaft models, ignore the shaded (orange) areas.

Motor Frame Size 85 mm (3.35 in.)

Model	Motor Model	Mass kg (lb.)	DXF
AR98AK-3	ARM98AK	1.9 (4.2)	B519
AR98BK-3	ARM98BK		

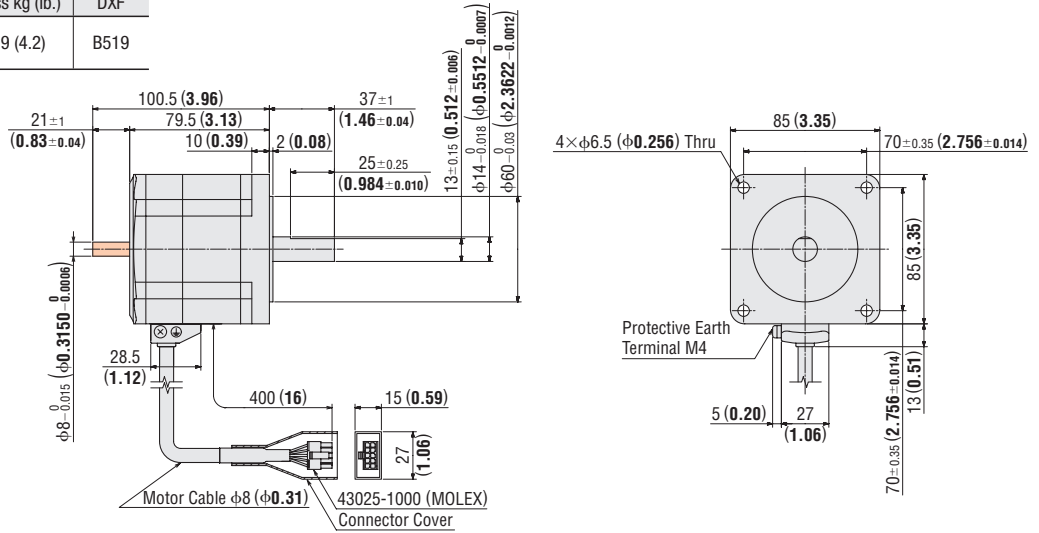

● These dimensions are for double shaft models. For single shaft models, ignore the shaded (orange) areas.

◇ Step Angle 0.36° Standard Type with Electromagnetic Brake

Motor Frame Size 42 mm (1.65 in.)

Model	Motor Model	Mass kg (lb.)	DXF
AR46MK-3	ARM46MK	0.62 (1.36)	B520

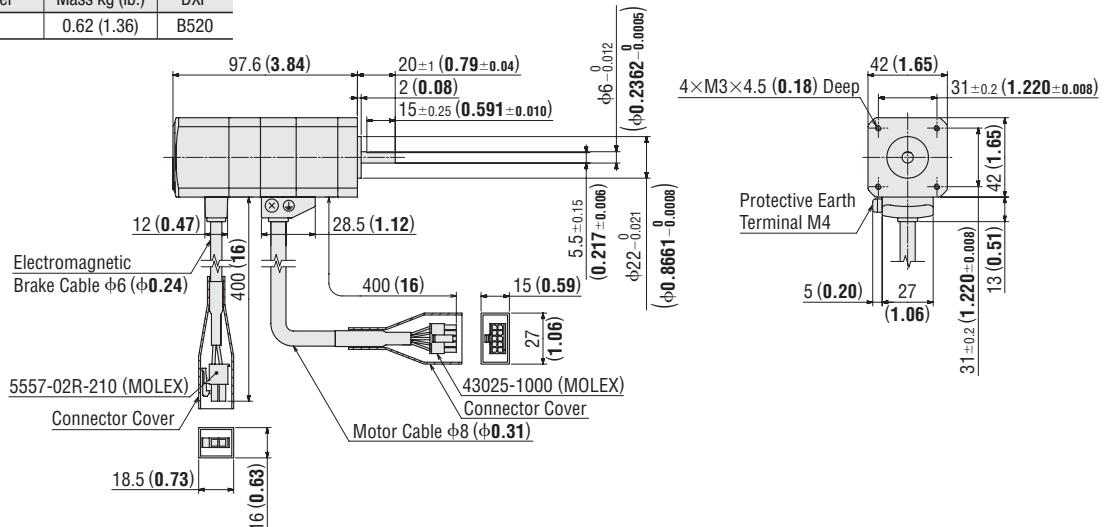

Motor Frame Size 60 mm (2.36 in.)

Model	Motor Model	L	Mass kg (lb.)	DXF
AR66MK-3	ARM66MK	99.5 (3.92)	1.2 (2.6)	B521
AR69MK-3	ARM69MK	125 (4.92)	1.7 (3.7)	B522

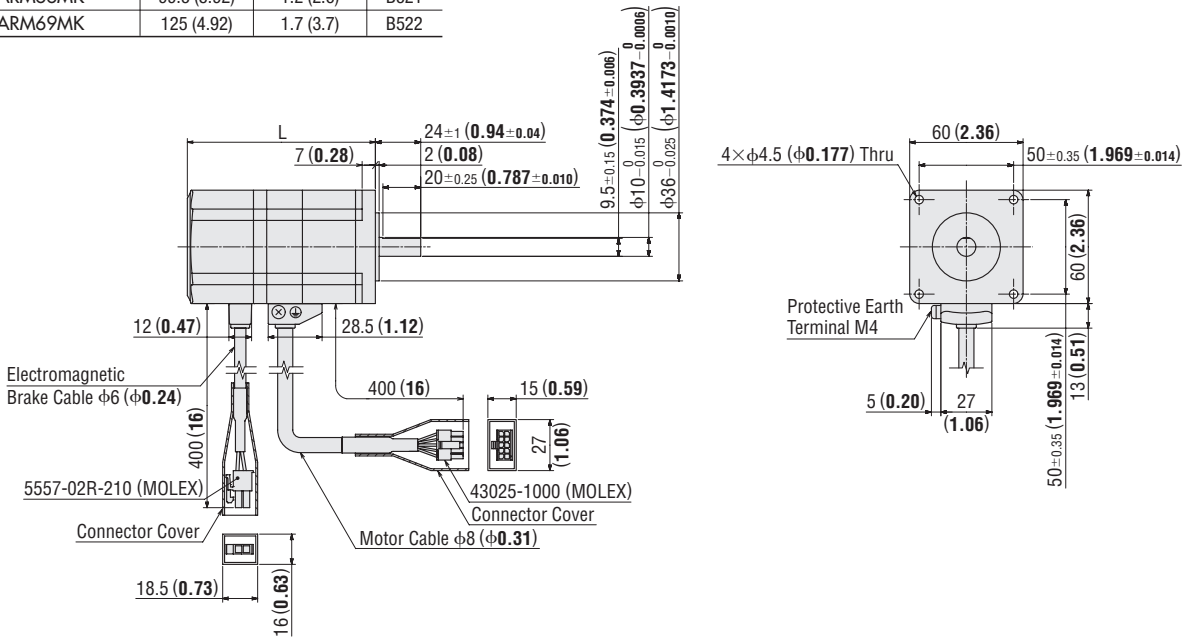

Motor Frame Size 85 mm (3.35 in.)

Model	Motor Model	Mass kg (lb.)	DXF
AR98MK-3	ARM98MK	2.5 (5.5)	B523

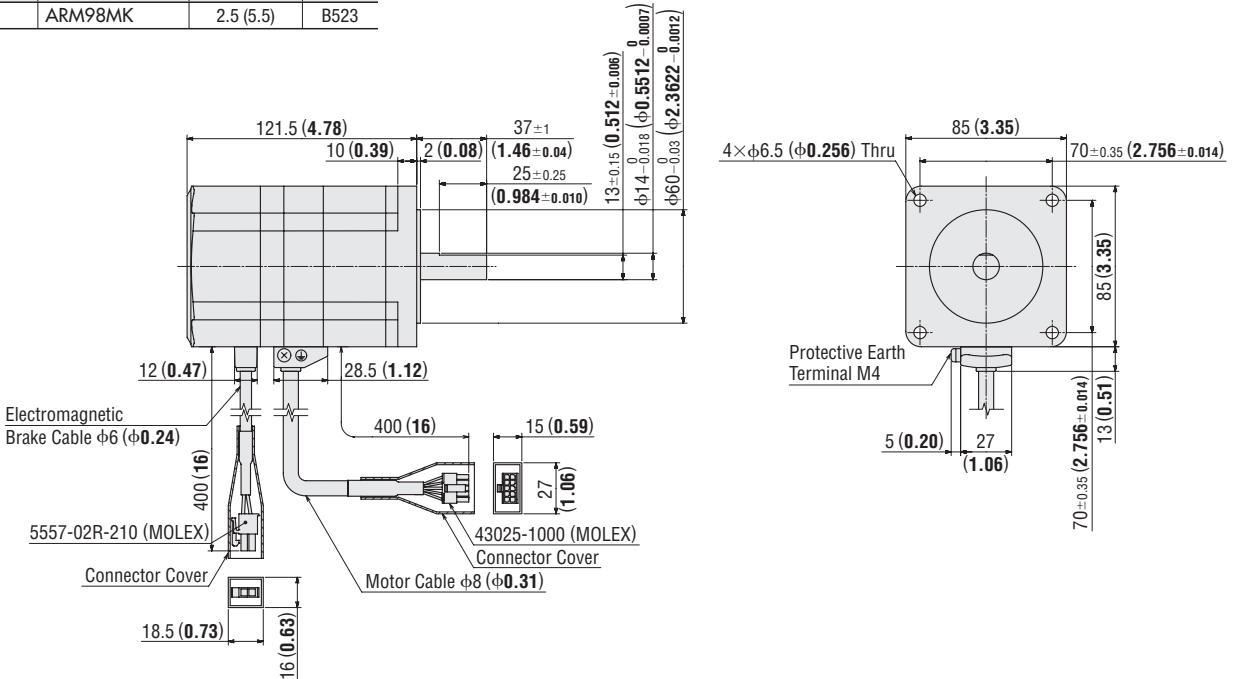

Introduction

AC Input Motor & Driver
AR^{STEP}/Geared
AR^{STEP}/AS

AC Input Motor & Driver
RK

AC Input Motor & Driver
UMK

AC Input Motor & Driver
AR^{STEP}

AC Input Motor & Driver
ASX

DC Input Motor & Driver
CRK

DC Input Motor & Driver
CMK

DC Input Motor & Driver
RBK

DC Input Motor & Driver
PK

DC Input Motor & Driver
PK

DC Input Motor & Driver
PK

DC Input Motor & Driver
PK/PV

DC Input Motor & Driver
Geared
PK

Controllers
SCX10
EMP400
/SG8030J

Accessories

◇ TH Geared Type

Motor Frame Size 28 mm (1.10 in.)

Model	Motor Model	Gear Ratio	Mass kg (lb.)	DXF
AR24SAK-T-3	ARM24SAK-T	7.2, 10, 20, 30	0.21 (7.4)	B707

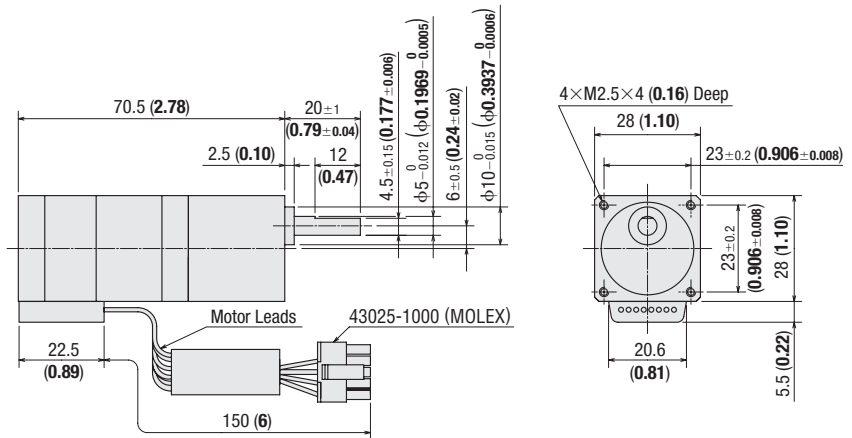

Motor Frame Size 42 mm (1.65 in.)

Model	Motor Model	Gear Ratio	Mass kg (lb.)	DXF
AR46AK-T-3	ARM46AK-T	3.6, 7.2, 10, 20, 30	0.62 (1.36)	B524

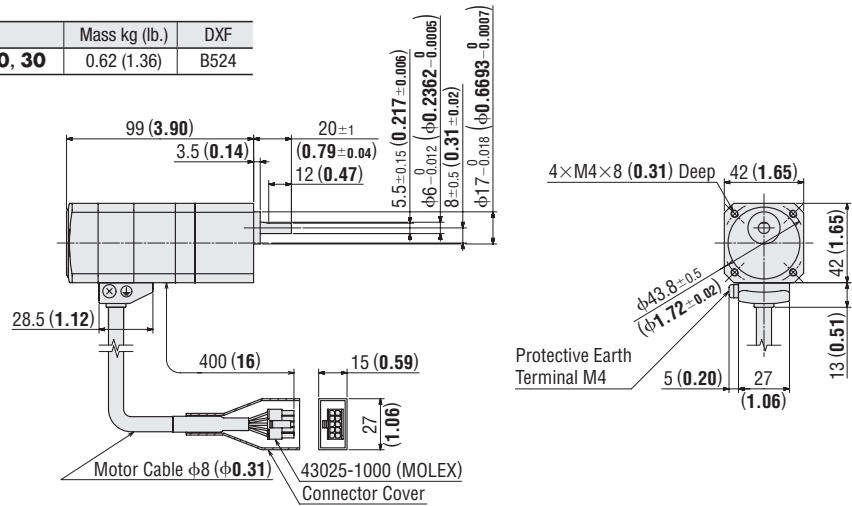

Motor Frame Size 60 mm (2.36 in.)

Model	Motor Model	Gear Ratio	Mass kg (lb.)	DXF
AR66AK-T-3	ARM66AK-T	3.6, 7.2, 10, 20, 30	1.3 (2.9)	B525

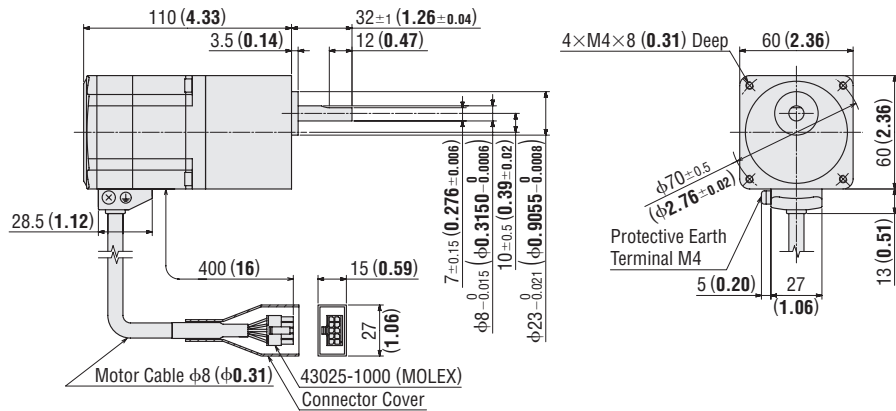

● A number indicating the gear ratio is entered where the box (■) is located within the model name.

Motor Frame Size 90 mm (3.54 in.)

Model	Motor Model	Gear Ratio	Mass kg (lb.)	DXF
AR98AK-T -3	ARM98AK-T	3.6, 7.2, 10, 20, 30	3.1 (6.8)	B526

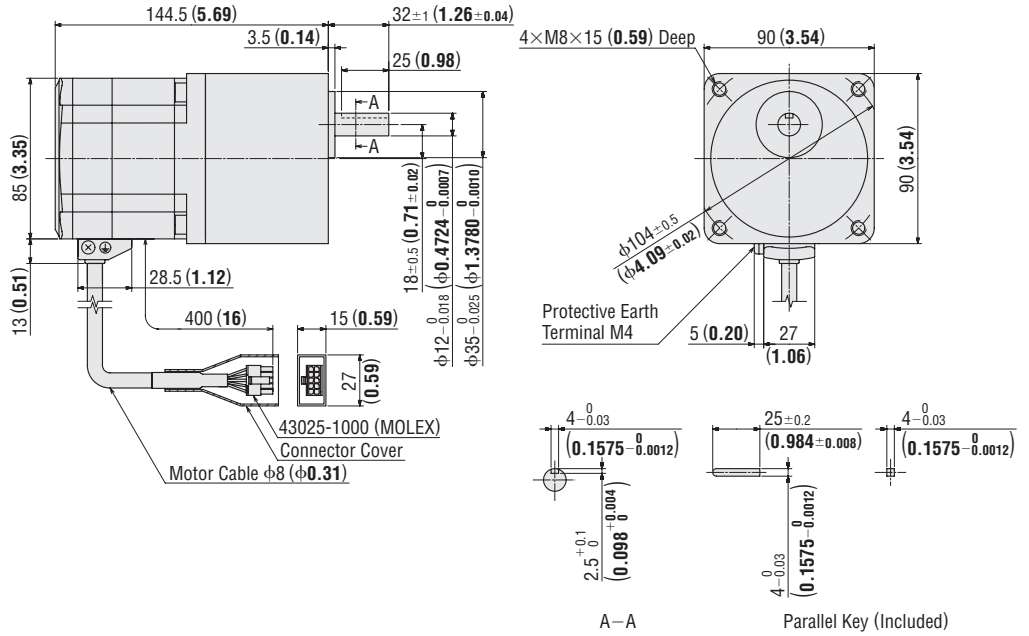

◇ TH Geared Type with Electromagnetic Brake

Motor Frame Size 42 mm (1.65 in.)

Model	Motor Model	Gear Ratio	Mass kg (lb.)	DXF
AR46MK-T -3	ARM46MK-T	3.6, 7.2, 10, 20, 30	0.77 (1.69)	B527

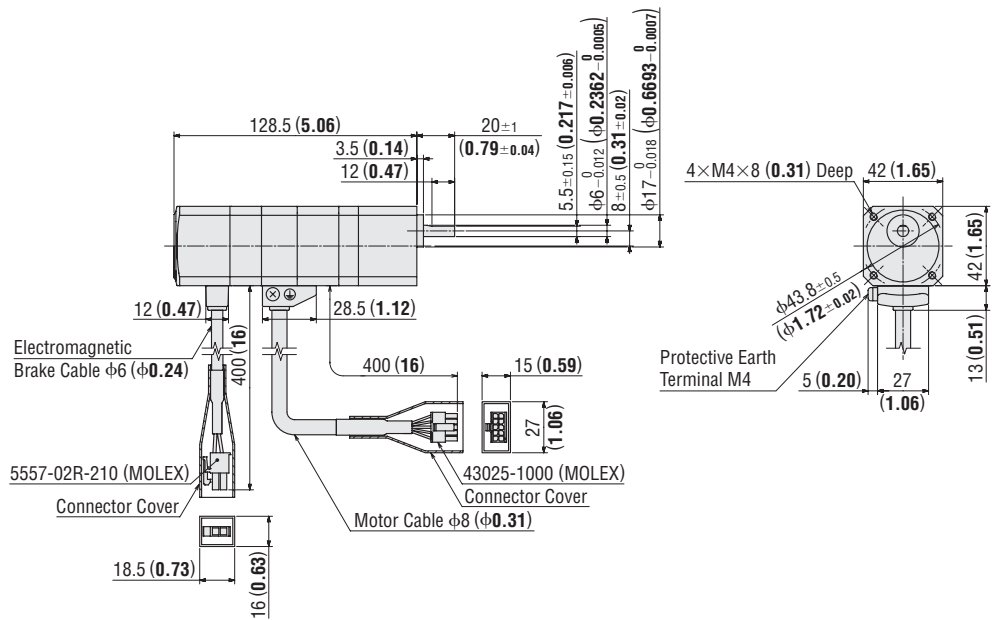

● A number indicating the gear ratio is entered where the box (■) is located within the model name.

Introduction	AC Input Motor & Driver	DC Input Motor & Driver	Motor Only	Controllers	Accessories
AR	0.36° / Geared	0.36° / Geared	0.36° / Geared	SCX10	
AS	0.72° / Geared	0.36° / Geared	0.72° / Geared	EMP400	
RK	0.9° / Geared	0.36° / Geared	0.9° / Geared	SG8030J	
UMK	0.9° / Geared	0.36° / Geared	0.9° / Geared		
AR	0.36° / Geared	0.36° / Geared	0.36° / Geared		
ASX	0.36° / Geared	0.36° / Geared	0.36° / Geared		
CRK	0.36° / Geared	0.36° / Geared	0.36° / Geared		
CMK	0.36° / Geared	0.36° / Geared	0.36° / Geared		
RBK	0.36° / Geared	0.36° / Geared	0.36° / Geared		
PK	0.36° / Geared	0.36° / Geared	0.36° / Geared		
PK	0.72° / Geared	0.36° / Geared	0.72° / Geared		
PK	0.9° / Geared	0.36° / Geared	0.9° / Geared		
PK/PV	1.8° / Geared	0.36° / Geared	1.8° / Geared		
PK	Geared	0.36° / Geared	Geared		

Motor Frame Size 60 mm (2.36 in.)

Model	Motor Model	Gear Ratio	Mass kg (lb.)	DXF
AR66MK-T-3	ARM66MK-T	3.6, 7.2, 10, 20, 30	1.6 (3.5)	B528

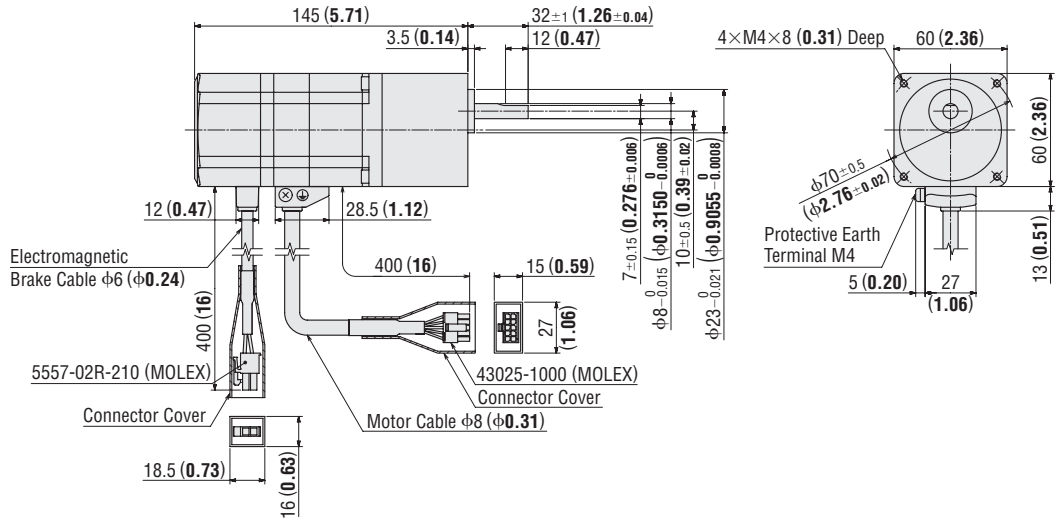

Motor Frame Size 90 mm (3.54 in.)

Model	Motor Model	Gear Ratio	Mass kg (lb.)	DXF
AR98MK-T-3	ARM98MK-T	3.6, 7.2, 10, 20, 30	3.7 (8.1)	B529

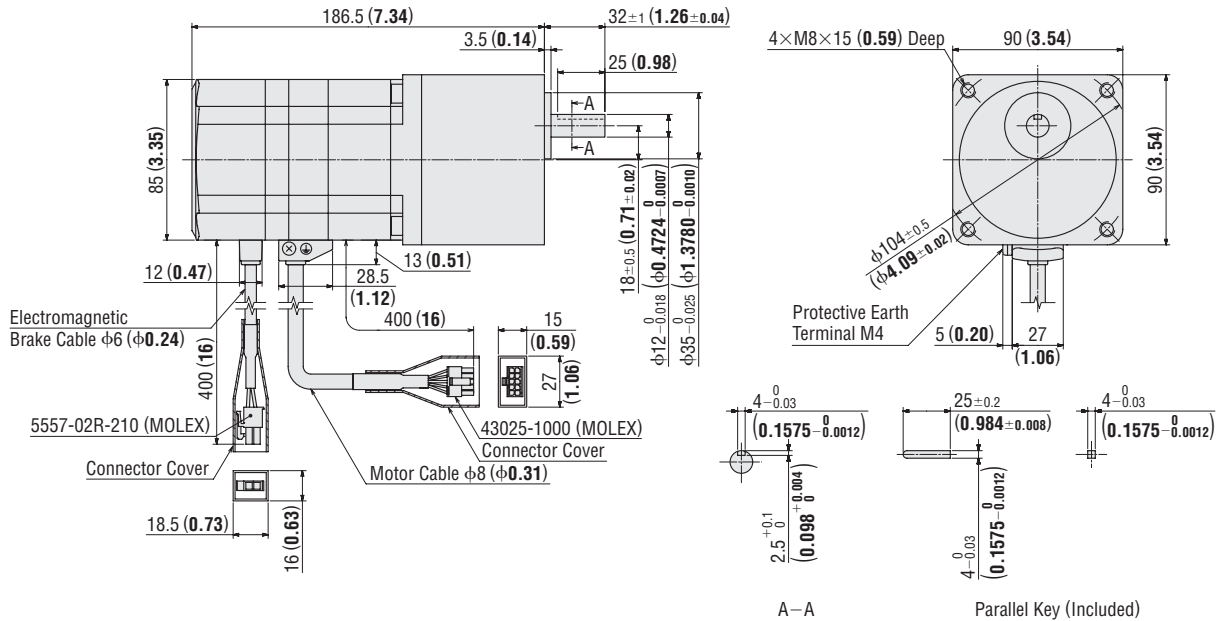

● A number indicating the gear ratio is entered where the box (■) is located within the model name.

◇ **PS Geared Type**

Motor Frame Size 28 mm (1.10 in.)

Model	Motor Model	Gear Ratio	Mass kg (lb.)	DXF
AR24SAK-PS-3	ARM24SAK-PS	5, 7.2, 10	0.25 (8.8)	B708

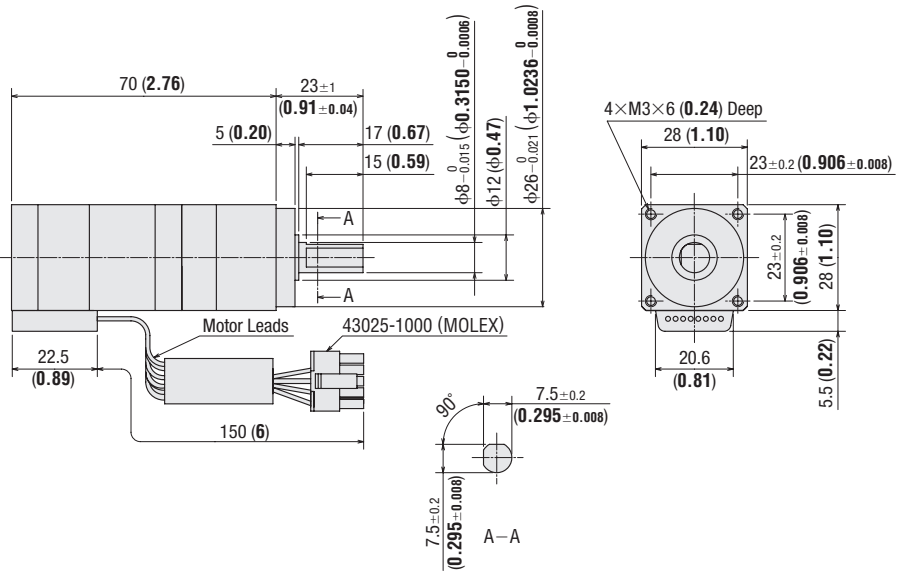

Motor Frame Size 42 mm (1.65 in.)

Model	Motor Model	Gear Ratio	L	Mass kg (lb.)	DXF
AR46AK-PS-3	ARM46AK-PS	5, 7.2, 10	96 (3.78)	0.67 (1.47)	B654
		25, 36, 50	119.5 (4.70)	0.82 (1.80)	B655

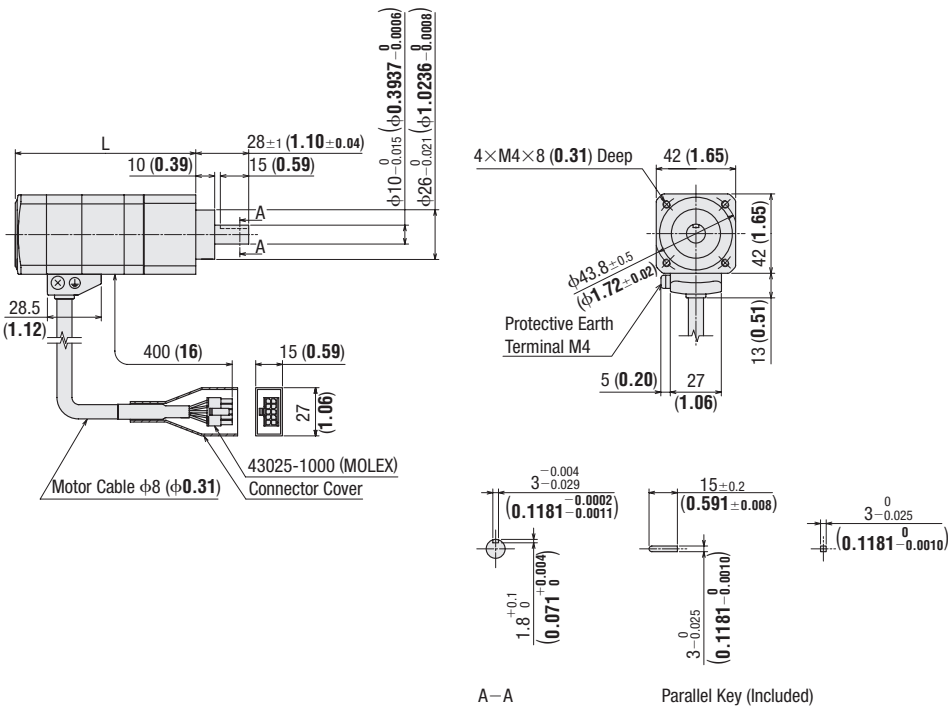

● A number indicating the gear ratio is entered where the box (■) is located within the model name.

Introduction	
AC Input Motor & Driver	0.36° / Geared / AR / AS
	0.72° / Geared / RK
	0.9° / 1.8° / Geared / UMK
DC Input Motor & Driver	0.36° / Geared / AR / ASX
	0.36° / 0.72° / Geared / CRK
	0.9° / 1.8° / Geared / CMK
	1.8° / Geared / RBK
	0.36° / PK
	0.72° / PK
Motor Only	0.9° / PK
	1.8° / PK / PV
	Geared / PK
Controllers	SCX10 / EMP400 / SG8030J
Accessories	

Motor Frame Size 60 mm (2.36 in.)

Model	Motor Model	Gear Ratio	L	Mass kg (lb.)	DXF
AR66AK-PS -3	ARM66AK-PS 	5, 7.2, 10	97 (3.82)	1.3 (2.9)	B658
		25, 36, 50	117 (4.61)	1.6 (3.5)	B659

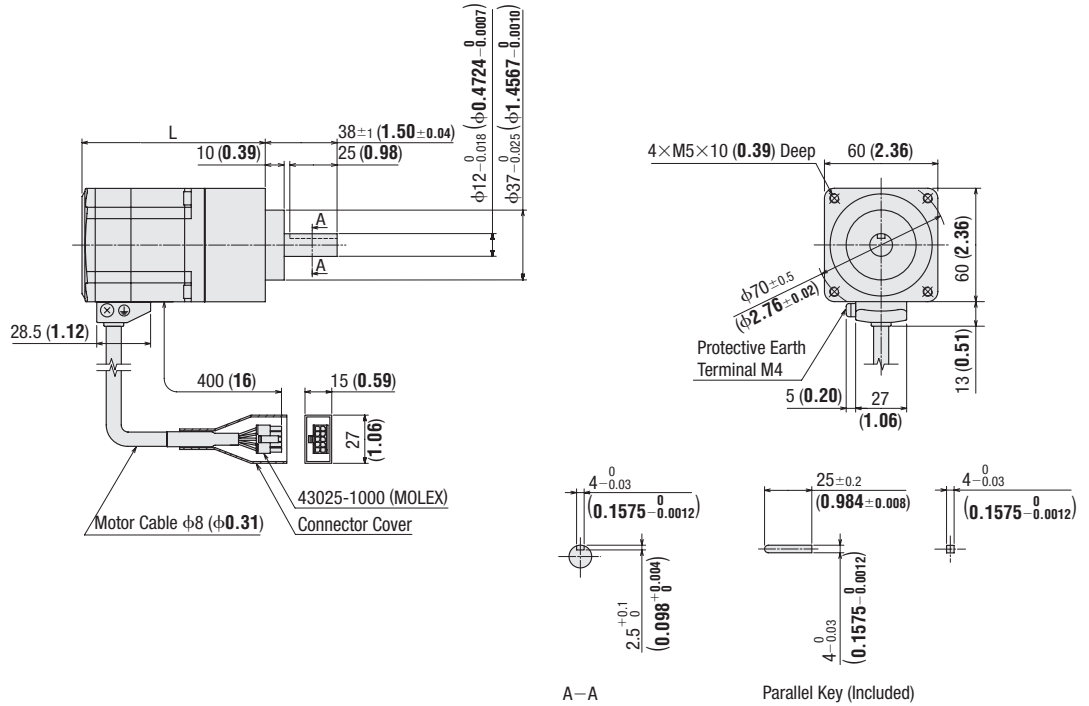

Motor Frame Size 90 mm (3.54 in.)

Model	Motor Model	Gear Ratio	L	Mass kg (lb.)	DXF
AR98AK-PS -3	ARM98AK-PS 	5, 7.2, 10	127 (5.00)	3.3 (7.3)	B662
		25, 36, 50	154.5 (6.08)	4.1 (9.0)	B663

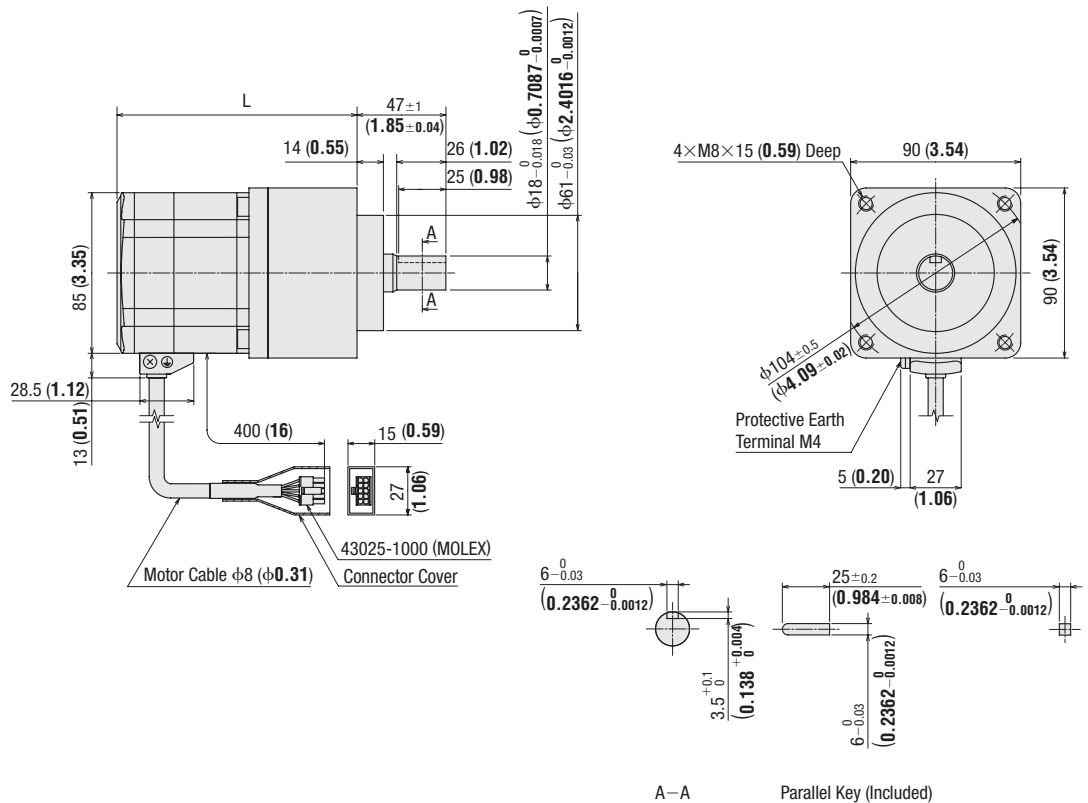

● A number indicating the gear ratio is entered where the box (■) is located within the model name.

◇ PS Geared Type with Electromagnetic Brake

Motor Frame Size 42 mm (1.65 in.)

Model	Motor Model	Gear Ratio	L	Mass kg (lb.)	DXF
AR46MK-PS ■-3	ARM46MK-PS■	5, 7.2, 10	125.5 (4.94)	0.82 (1.80)	B656
		25, 36, 50	149 (5.87)	0.97 (2.1)	B657

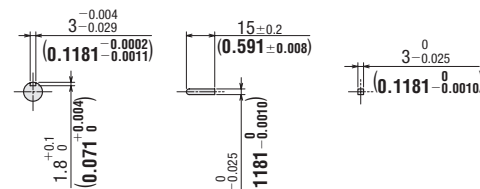
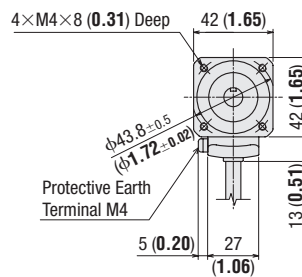
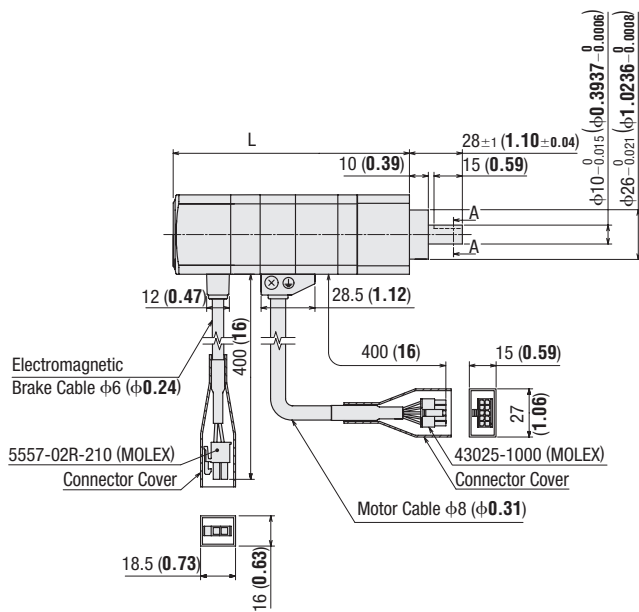

A-A Parallel Key (Included)

Motor Frame Size 60 mm (2.36 in.)

Model	Motor Model	Gear Ratio	L	Mass kg (lb.)	DXF
AR66MK-PS ■-3	ARM66MK-PS■	5, 7.2, 10	132 (5.20)	1.6 (3.5)	B660
		25, 36, 50	152 (5.98)	1.9 (4.2)	B661

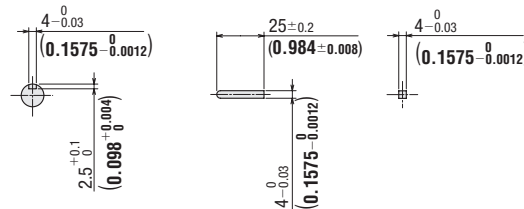
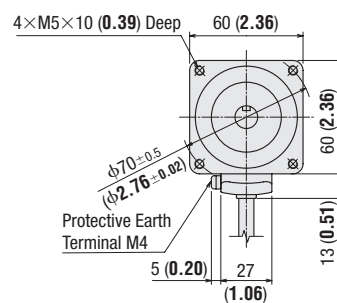
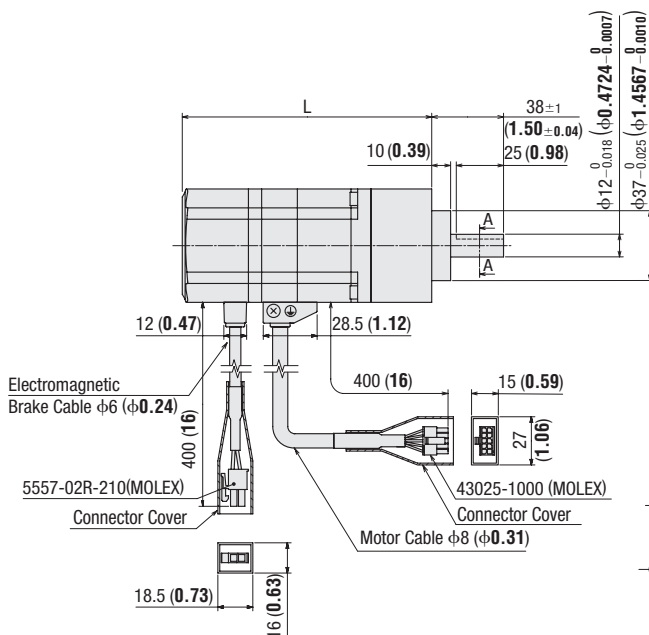

A-A Parallel Key (Included)

● A number indicating the gear ratio is entered where the box (■) is located within the model name.

Introduction	
AR	AC Input Motor & Driver
AR	Geared
AS	0.36°
AS	0.72°
AS	0.9°/1.8°
ASX	DC Input Motor & Driver
ASX	0.36°
ASX	0.36°
CRK	0.36°/0.72°
CRK	Geared
CMK	0.9°/1.8°
CMK	Geared
RBK	1.8°
RBK	Geared
PK	0.36°
PK	0.72°
PK	0.9°
PK/PV	1.8°
PK	Geared
SCX10	Controllers
EMP400	SCX10
5G8030J	EMP400
	Accessories

Motor Frame Size 90 mm (3.54 in.)

Model	Motor Model	Gear Ratio	L	Mass kg (lb.)	DXF
AR98MK-PS-3	ARM98MK-PS	5, 7.2, 10	169 (6.65)	3.9 (8.6)	B664
		25, 36, 50	196.5 (7.74)	4.7 (10.3)	B665

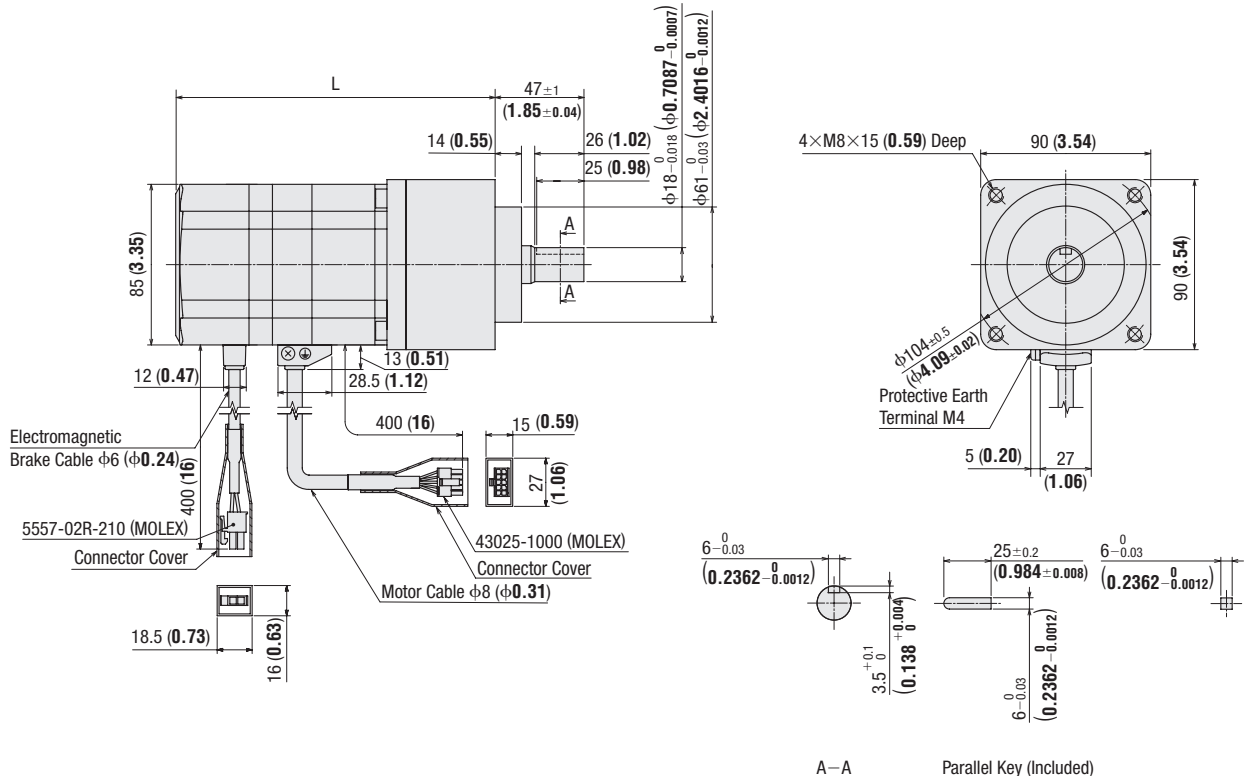

◇ PN Geared Type

Motor Frame Size 28 mm (1.10 in.)

Model	Motor Model	Gear Ratio	Mass kg (lb.)	DXF
AR24SAK-N-3	ARM24SAK-N	5, 7.2, 10	0.28 (9.9)	B709

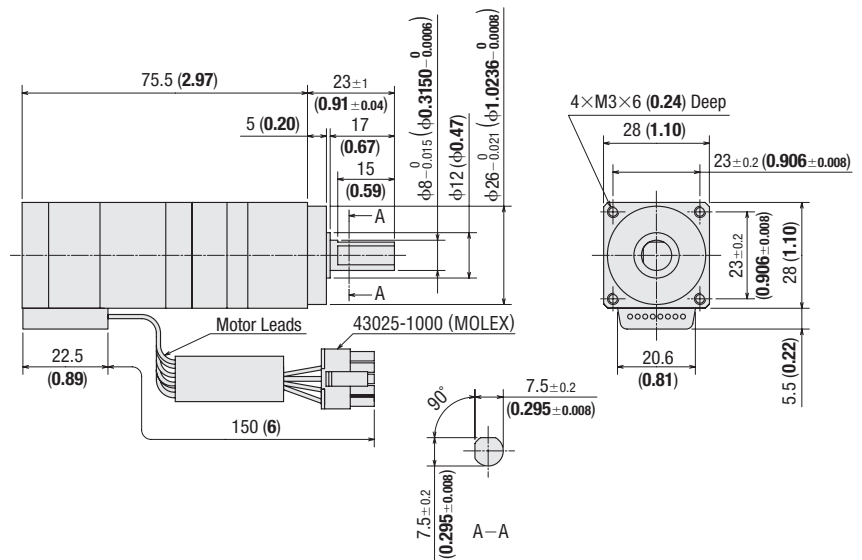

● A number indicating the gear ratio is entered where the box (■) is located within the model name.

Motor Frame Size 42 mm (1.65 in.)

Model	Motor Model	Gear Ratio	Mass kg (lb.)	DXF
AR46AK-N ■-3	ARM46AK-N■	5, 7.2, 10	0.73 (1.61)	B530

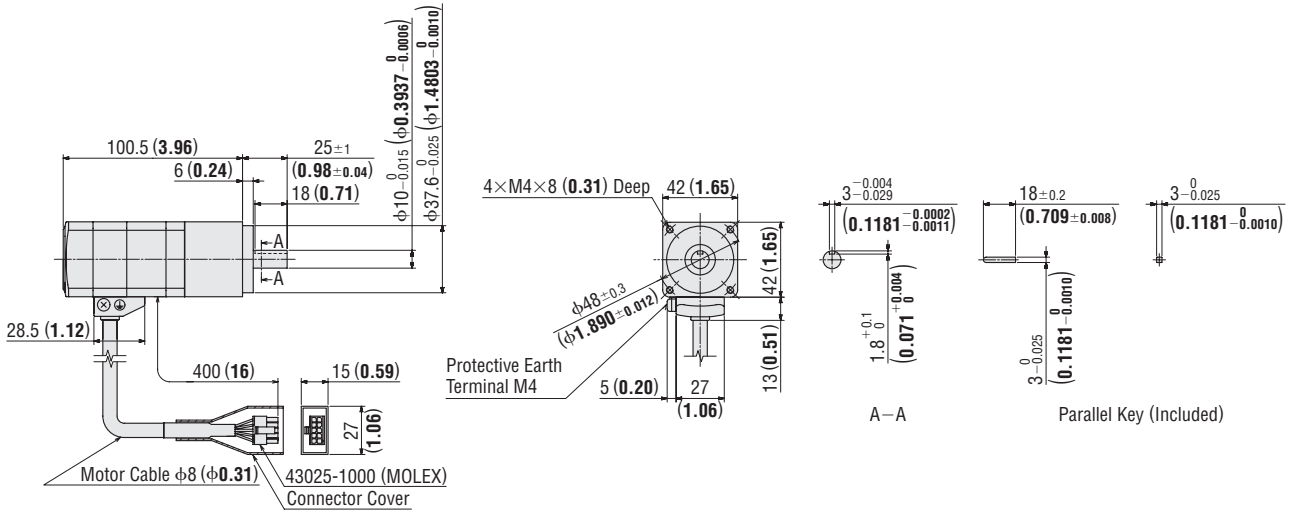

Motor Frame Size 60 mm (2.36 in.)

Model	Motor Model	Gear Ratio	L	Mass kg (lb.)	DXF
AR66AK-N ■-3	ARM66AK-N■	5, 7.2, 10	109 (4.29)	1.5 (3.3)	B531
		25, 36, 50	125 (4.92)	1.73 (3.8)	B532

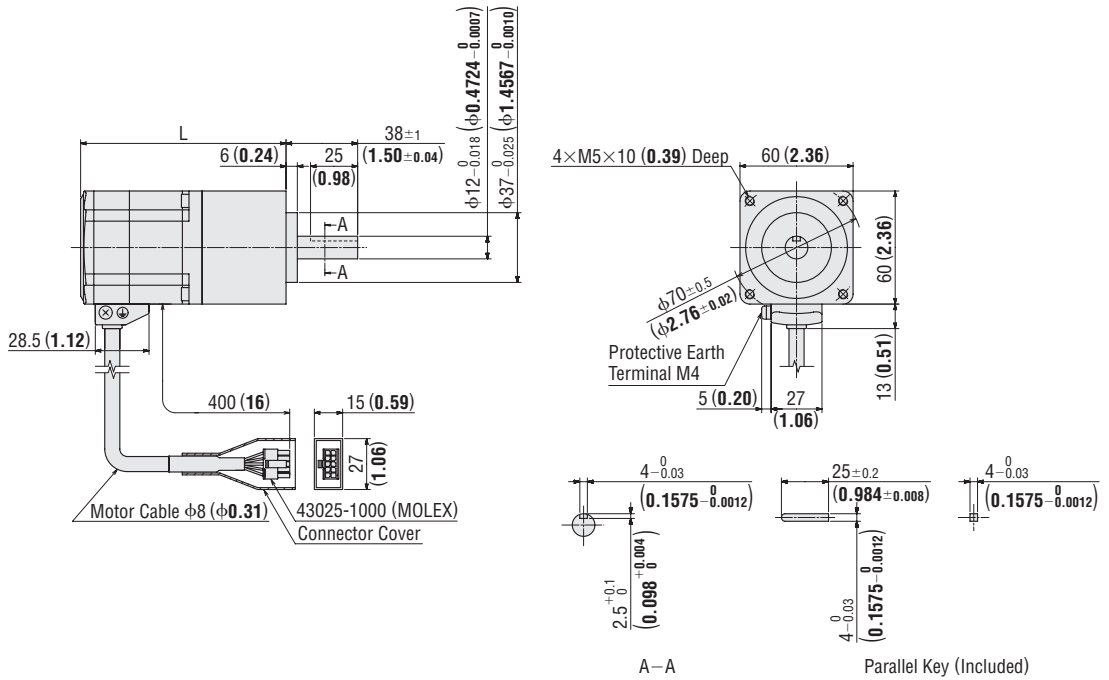

● A number indicating the gear ratio is entered where the box (■) is located within the model name.

Introduction	AC Input Motor & Driver	DC Input Motor & Driver	Motor Only	Controllers	Accessories
AR	0.36° / Geared / AS	0.36° / Geared / ASX	0.36° / Geared / CRK	PK	
	0.72° / Geared / RK	0.36° / Geared / CMK	0.36° / Geared / RBK	PK	
	0.9° / Geared / UMK	0.9° / Geared / PK	0.72° / Geared / PK	PK	
	0.36° / Geared / AR	0.36° / Geared / PK	0.9° / Geared / PK	PK/PV	
		1.8° / Geared / PK/PV	1.8° / Geared / PK		
				SCX10 / EMP400 / SG8030J	

Motor Frame Size 90 mm (3.54 in.)

Model	Motor Model	Gear Ratio	L	Mass kg (lb.)	DXF
AR98AK-N ■-3	ARM98AK-N■	5, 7.2, 10	140 (5.51)	3.8 (8.4)	B533
		25, 36, 50	163 (6.42)	4.5 (9.9)	B534

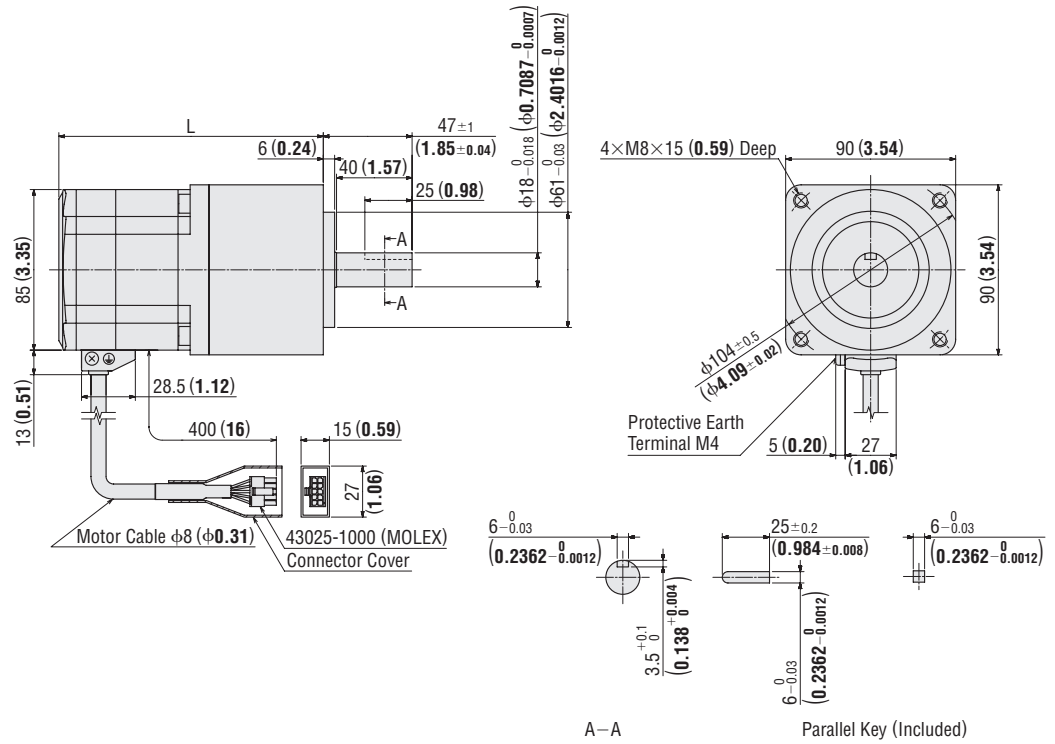

◇ PN Geared Type with Electromagnetic Brake

Motor Frame Size 42 mm (1.65 in.)

Model	Motor Model	Gear Ratio	Mass kg (lb.)	DXF
AR46MK-N ■-3	ARM46MK-N■	5, 7.2, 10	0.88 (1.94)	B535

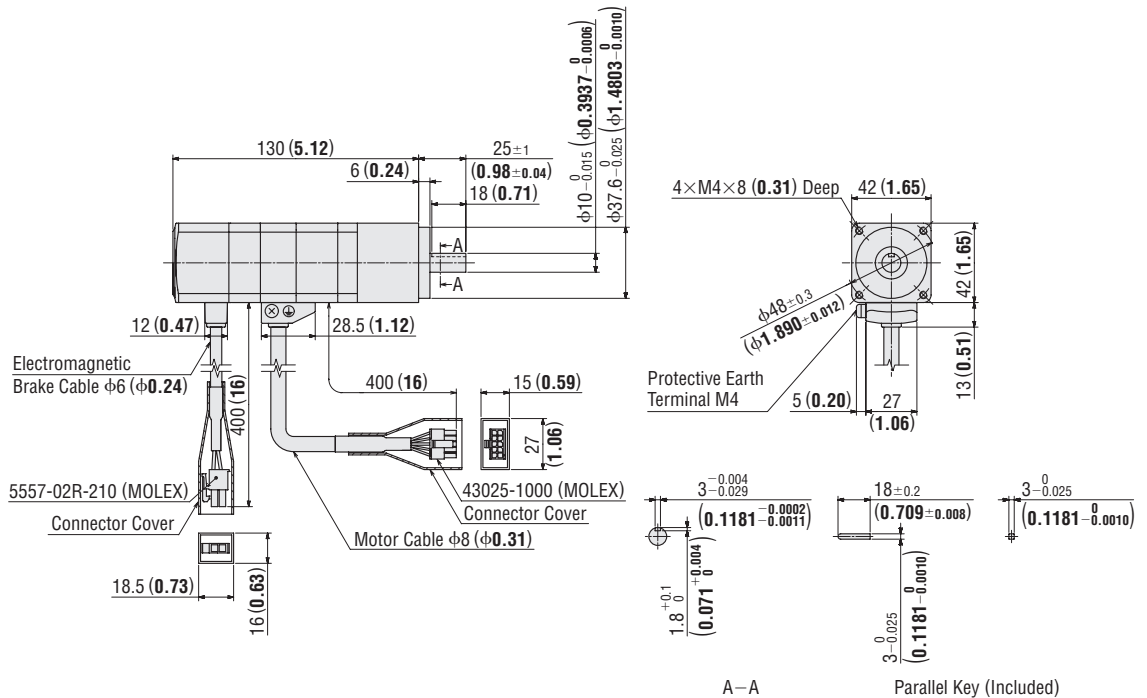

● A number indicating the gear ratio is entered where the box (■) is located within the model name.

Motor Frame Size 60 mm (2.36 in.)

Model	Motor Model	Gear Ratio	L	Mass kg (lb.)	DXF
AR66MK-N ■-3	ARM66MK-N■	5, 7.2, 10	144 (5.67)	1.8 (4.0)	B536
		25, 36, 50	160 (6.30)	2.0 (4.4)	B537

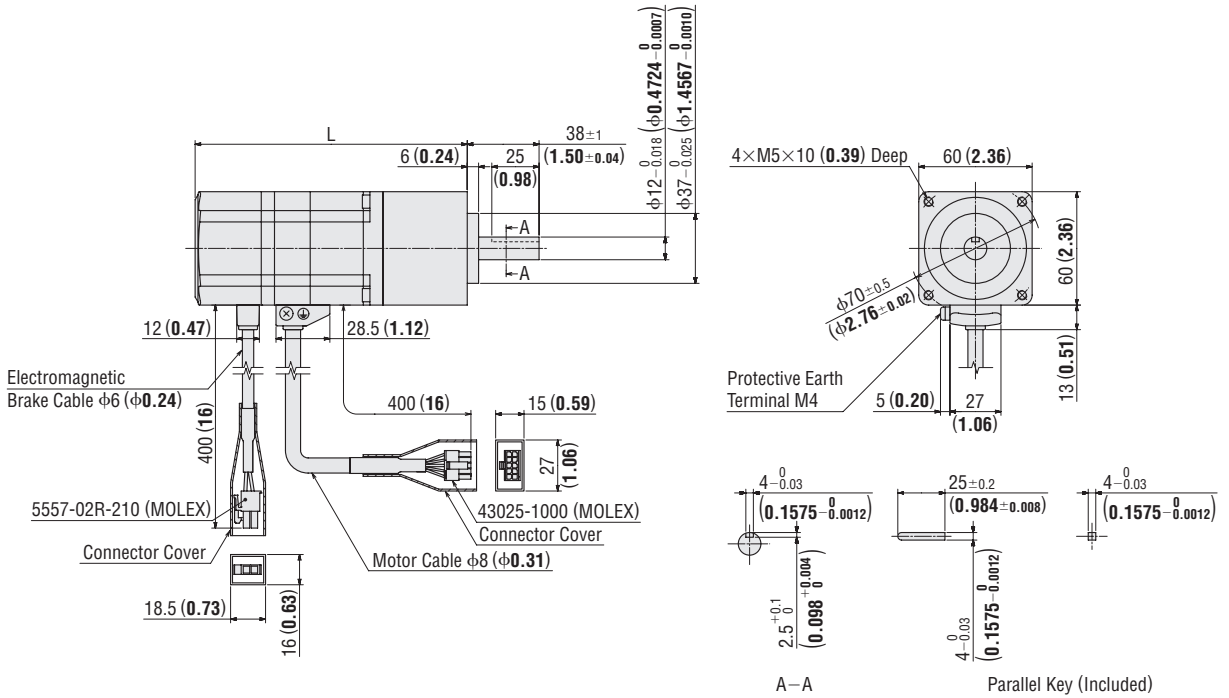

Motor Frame Size 90 mm (3.54 in.)

Model	Motor Model	Gear Ratio	L	Mass kg (lb.)	DXF
AR98MK-N ■-3	ARM98MK-N■	5, 7.2, 10	182 (7.17)	4.4 (9.7)	B538
		25, 36, 50	205 (8.07)	5.1 (11.2)	B539

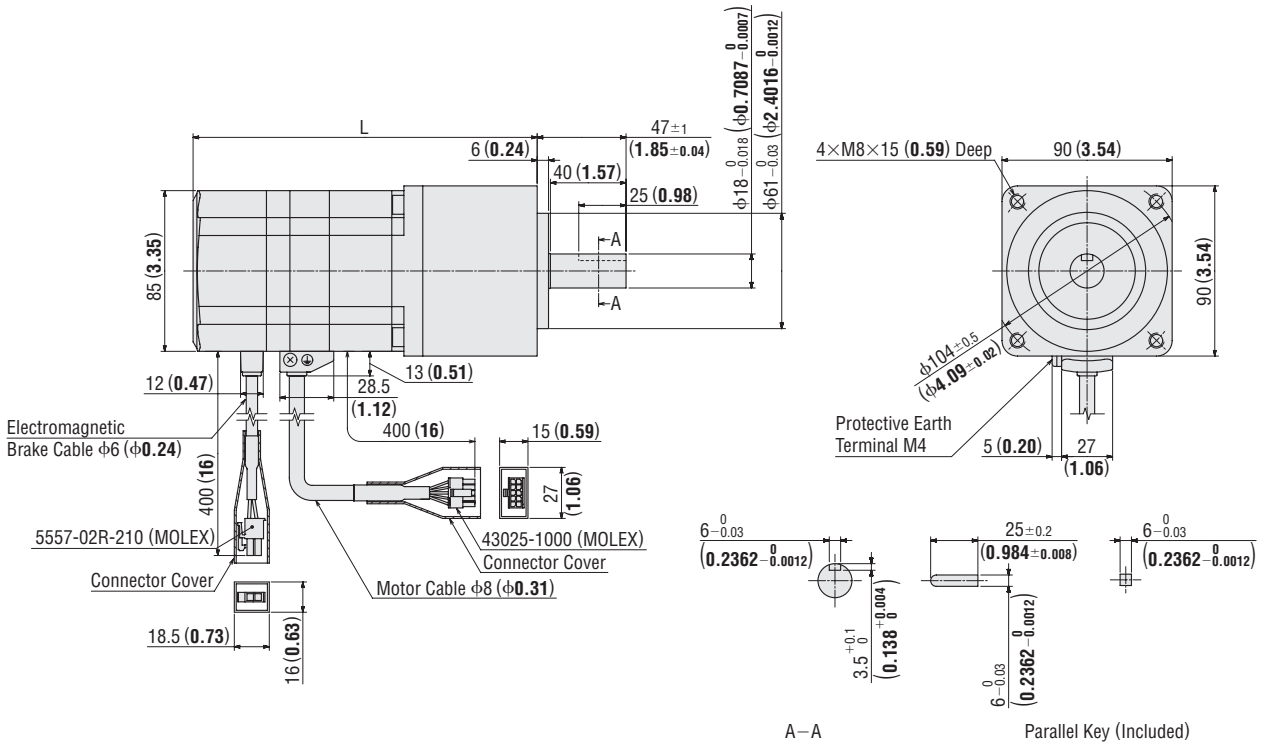

● A number indicating the gear ratio is entered where the box (■) is located within the model name.

Introduction	AC Input Motor & Driver	Motor Only	Controllers	Accessories
AR	0.36° / Geared	PK	SCX10	
AS	0.72° / Geared	PK	EMP400	
UMK	0.9° / 1.8°	PK	/SG8030J	
AR	0.36° / Geared	PK		
ASX	0.36°	PK/PV		
CRK	0.36°/0.72° / Geared	PK		
CMK	0.9° / 1.8° / Geared	PK		
RBK	1.8° / Geared	PK		

◇ Harmonic Geared Type

Motor Frame Size 30 mm (1.18 in.)

Model	Motor Model	Gear Ratio	Mass kg (lb.)	DXF
AR24SAK-H ■-3	ARM24SAK-H■	50, 100	0.24 (8.5)	B710

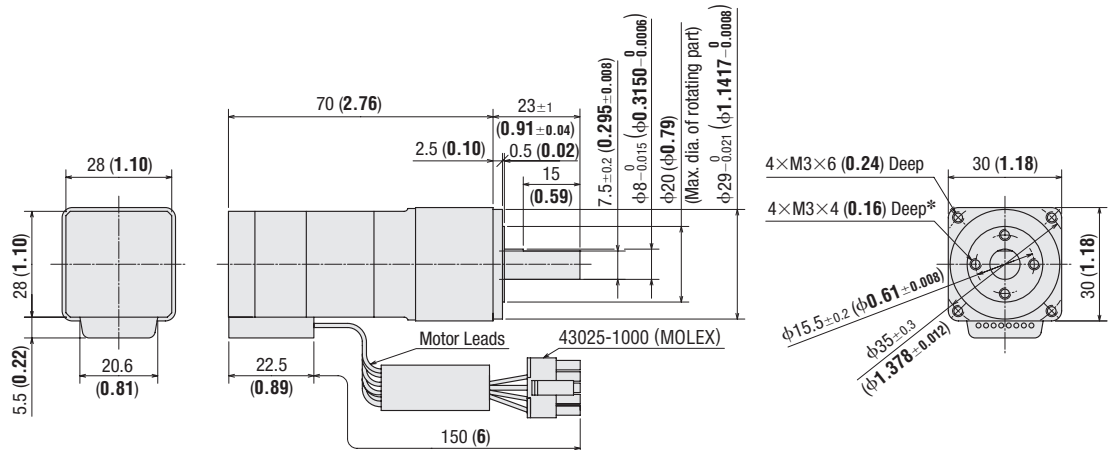

Motor Frame Size 42 mm (1.65 in.)

Model	Motor Model	Gear Ratio	Mass kg (lb.)	DXF
AR46AK-H ■-3	ARM46AK-H■	50, 100	0.68 (1.5)	B540

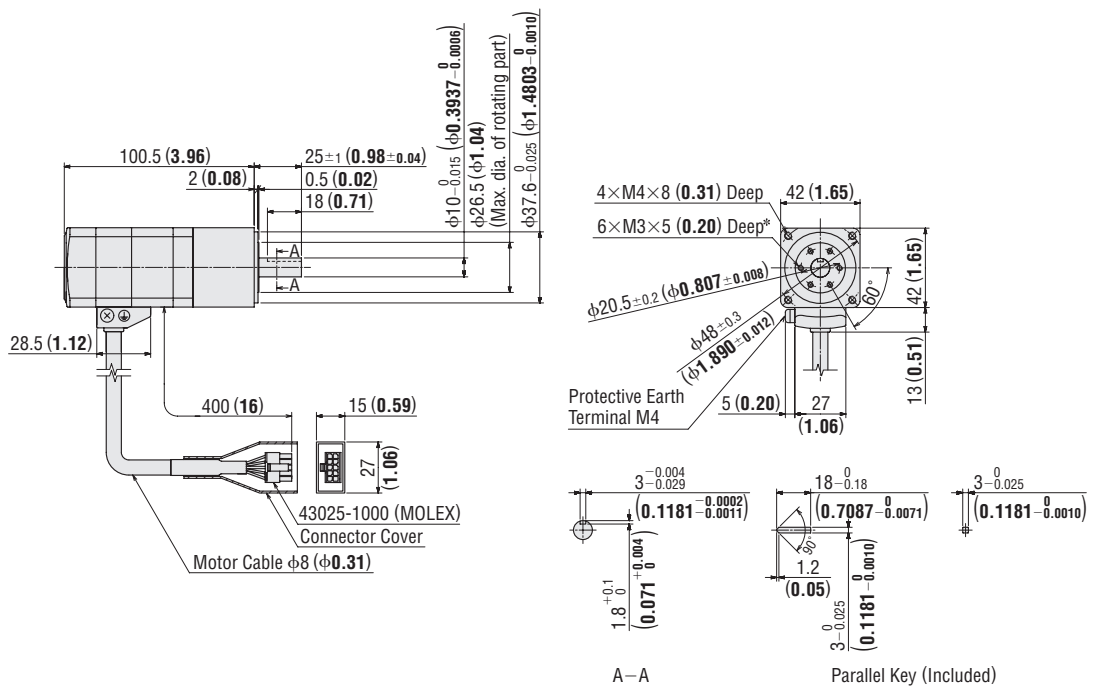

*The position of the output shaft relative to the screw holes on the rotating part is arbitrary.

● A number indicating the gear ratio is entered where the box (■) is located within the model name.

Motor Frame Size 60 mm (2.36 in.)

Model	Motor Model	Gear Ratio	Mass kg (lb.)	DXF
AR66AK-H ■-3	ARM66AK-H■	50, 100	1.41 (3.1)	B541

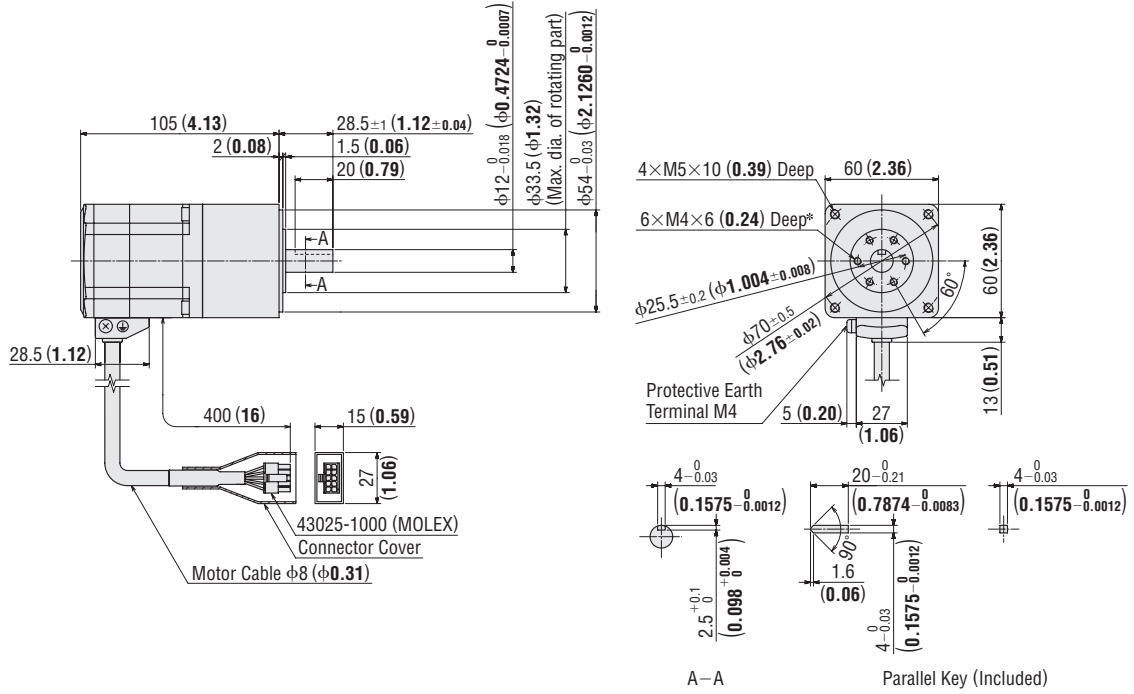

*The position of the output shaft relative to the screw holes on the rotating part is arbitrary.

Motor Frame Size 90 mm (3.54 in.)

Model	Motor Model	Gear Ratio	Mass kg (lb.)	DXF
AR98AK-H ■-3	ARM98AK-H■	50, 100	4.0 (8.8)	B542

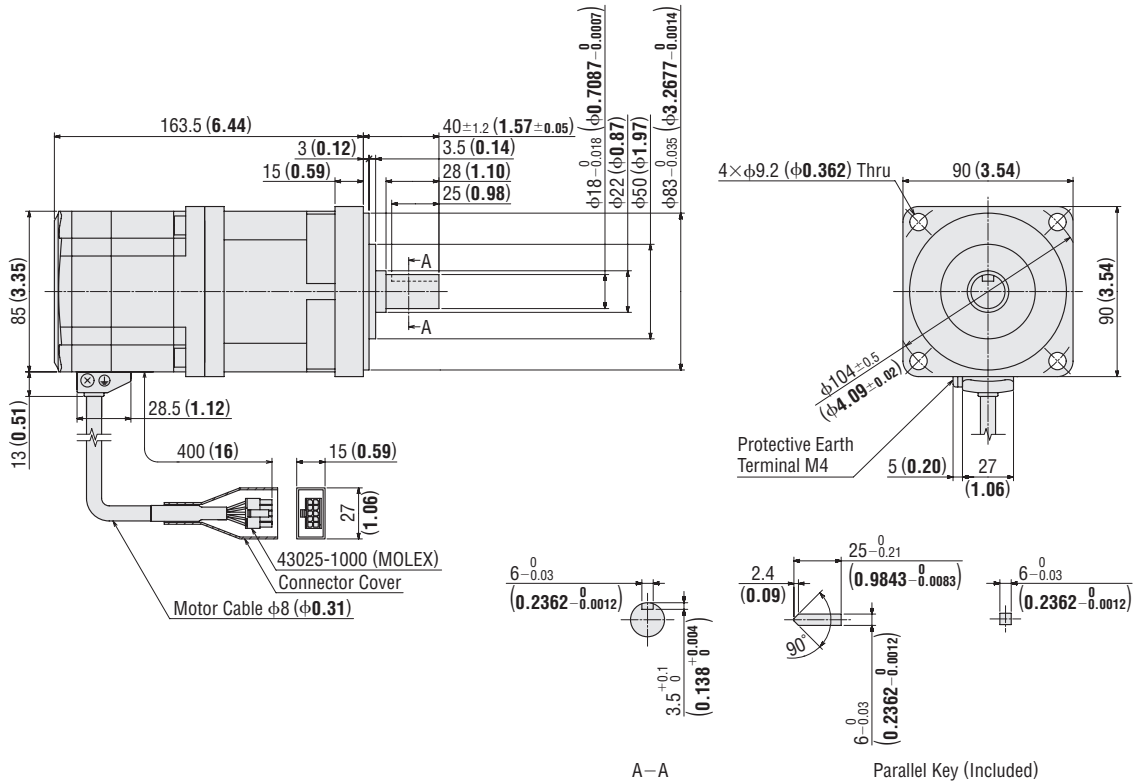

● A number indicating the gear ratio is entered where the box (■) is located within the model name.

Introduction	AC Input Motor & Driver	DC Input Motor & Driver	Motor Only	Controllers	Accessories
AR	0.36° / Geared	0.36° / Geared	0.36° / Geared	SCX10	
AS	0.72° / Geared	0.36° / Geared	0.36° / Geared	EMP400	
ASX	0.9° / Geared	0.36° / Geared	0.36° / Geared	SG8030J	
CRK	0.9° / Geared	0.36° / Geared	0.36° / Geared		
CMK	1.8° / Geared	0.36° / Geared	0.36° / Geared		
RBK	1.8° / Geared	0.36° / Geared	0.36° / Geared		
PK	0.36° / Geared	0.36° / Geared	0.36° / Geared		
PK	0.72° / Geared	0.36° / Geared	0.72° / Geared		
PK	0.9° / Geared	0.36° / Geared	0.9° / Geared		
PK/PV	1.8° / Geared	0.36° / Geared	1.8° / Geared		
PK	Geared	0.36° / Geared	Geared		

◇ Harmonic Geared Type with Electromagnetic Brake

Motor Frame Size 42 mm (1.65 in.)

Model	Motor Model	Gear Ratio	Mass kg (lb.)	DXF
AR46MK-H-3	ARM46MK-H	50, 100	0.83 (1.83)	B543

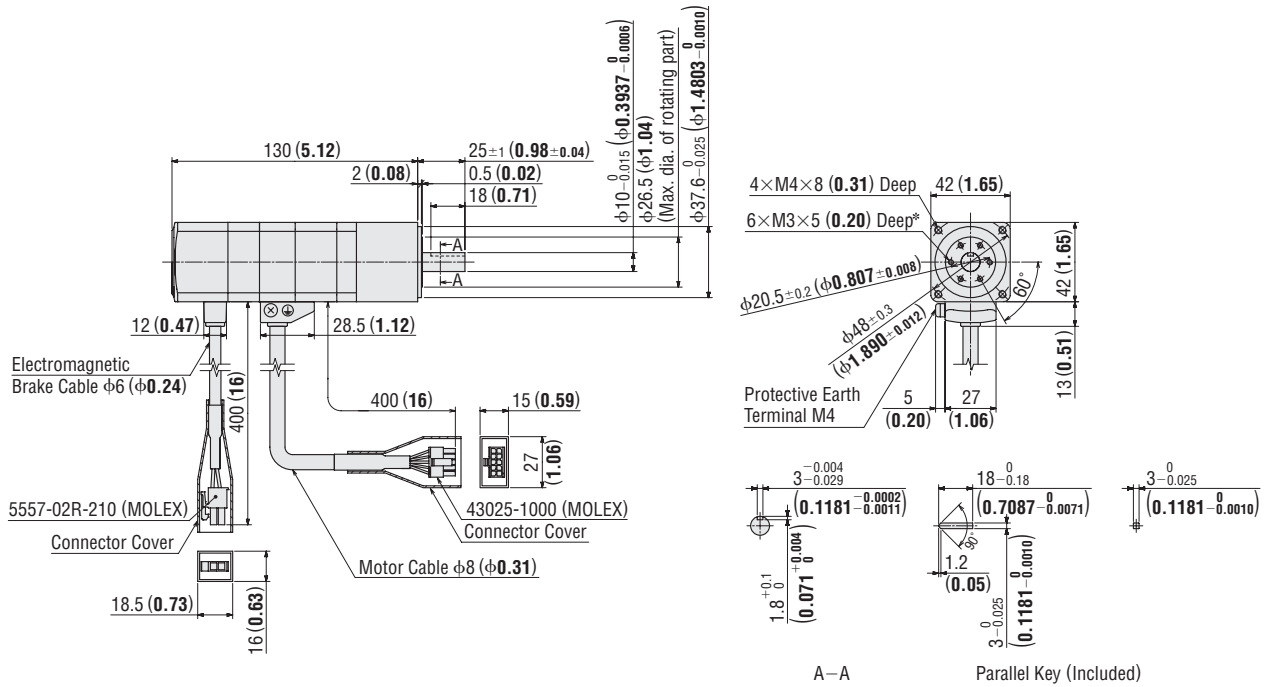

* The position of the output shaft relative to the screw holes on the rotating part is arbitrary.

Motor Frame Size 60 mm (2.36 in.)

Model	Motor Model	Gear Ratio	Mass kg (lb.)	DXF
AR66MK-H-3	ARM66MK-H	50, 100	1.71 (3.8)	B544

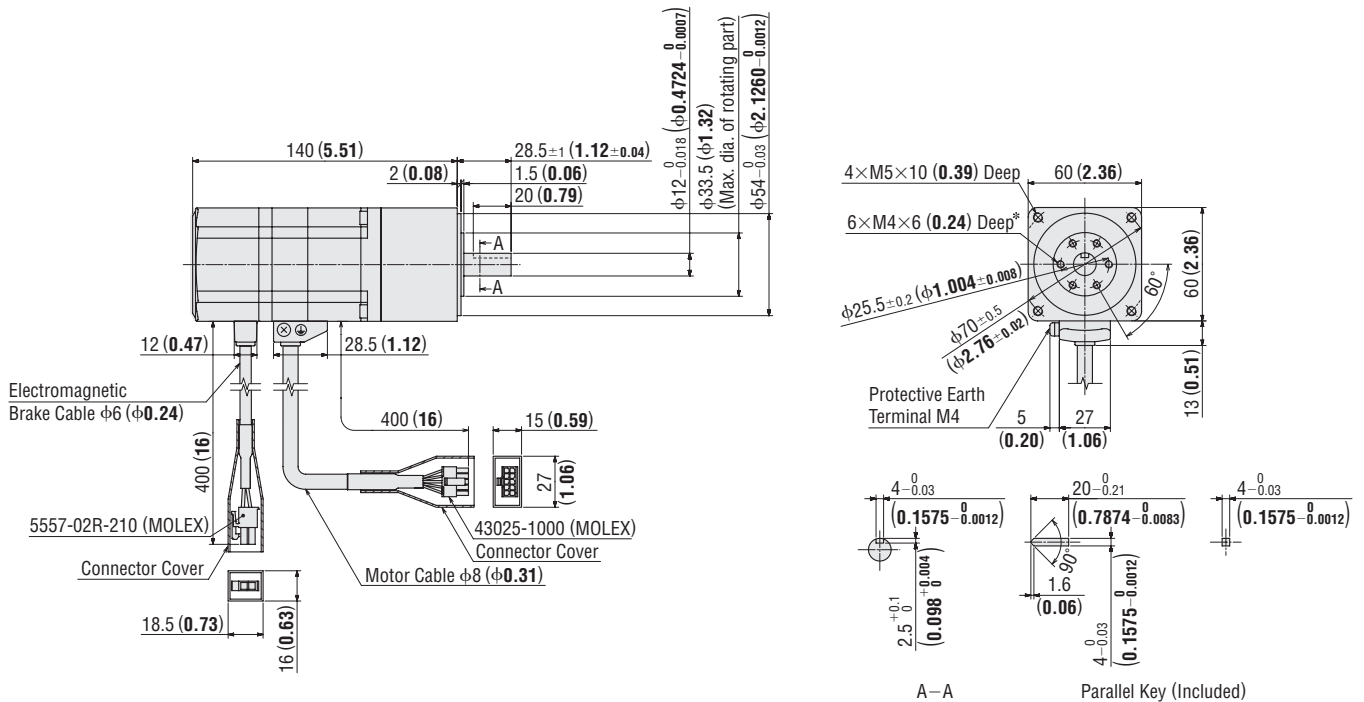

* The position of the output shaft relative to the screw holes on the rotating part is arbitrary.

● A number indicating the gear ratio is entered where the box (■) is located within the model name.

Motor Frame Size 90 mm (3.54 in.)

Model	Motor Model	Gear Ratio	Mass kg (lb.)	DXF
AR98MK-H 3	ARM98MK-H 	50, 100	4.6 (10.1)	B545

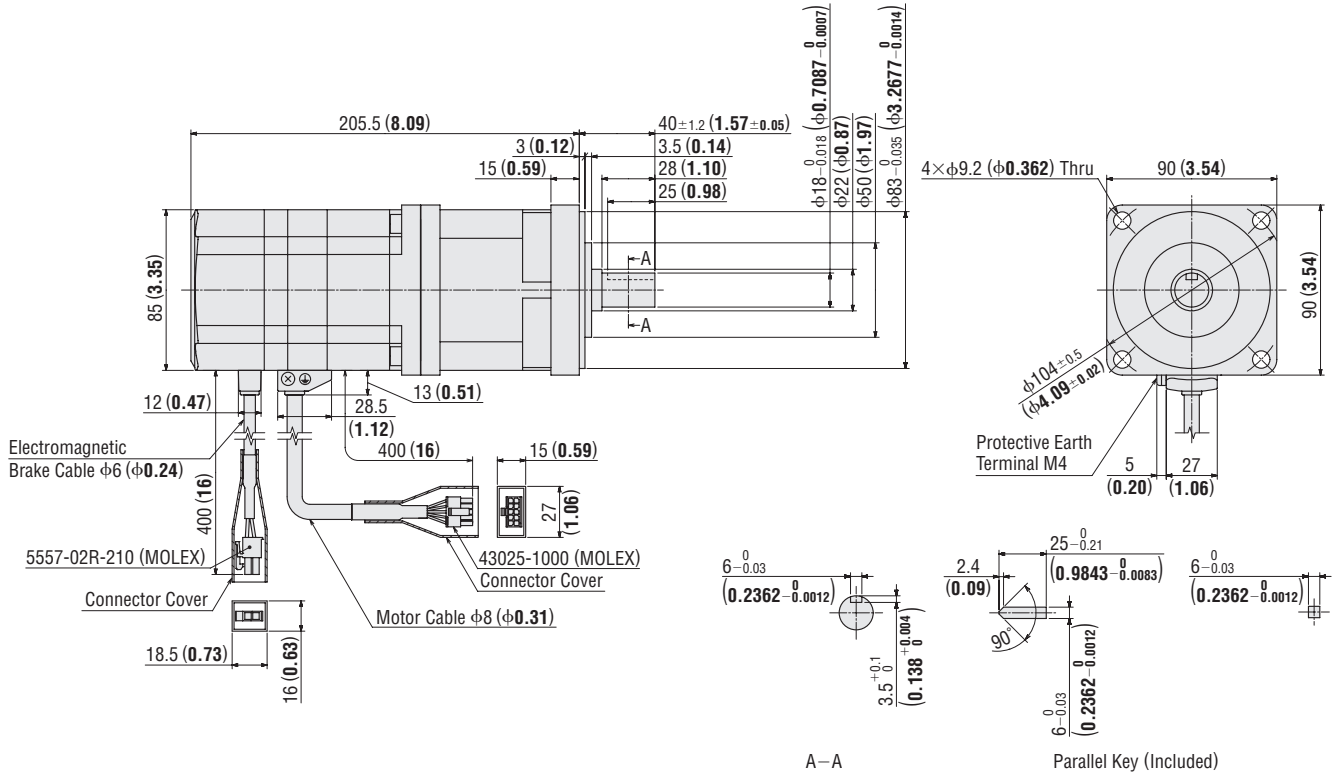

● A number indicating the gear ratio is entered where the box (■) is located within the model name.

Introduction	AC Input Motor & Driver	DC Input Motor & Driver	Motor Only	Controllers	Accessories
AR	0.36° / Geared	0.36° / Geared	0.36° / Geared	SCX10	
AR	0.72° / Geared	0.36° / Geared	0.36° / Geared	EMP400	
AS	0.9° / Geared	0.36° / Geared	0.36° / Geared	SG8030J	
AS	1.8° / Geared	0.36° / Geared	0.36° / Geared		
RK	0.9° / Geared	0.36° / Geared	0.36° / Geared		
UMK	0.9° / Geared	0.36° / Geared	0.36° / Geared		
AR	0.36° / Geared	0.36° / Geared	0.36° / Geared		
ASX	0.36° / Geared	0.36° / Geared	0.36° / Geared		
CRK	0.36° / Geared	0.36° / Geared	0.36° / Geared		
CMK	0.36° / Geared	0.36° / Geared	0.36° / Geared		
RBK	0.36° / Geared	0.36° / Geared	0.36° / Geared		
PK	0.36° / Geared	0.36° / Geared	0.36° / Geared		
PK	0.72° / Geared	0.36° / Geared	0.36° / Geared		
PK	0.9° / Geared	0.36° / Geared	0.36° / Geared		
PK/PV	1.8° / Geared	0.36° / Geared	0.36° / Geared		
PK	Geared	0.36° / Geared	0.36° / Geared		

● Driver

Mass: 0.17 kg (0.37 lb.)

DXF B546

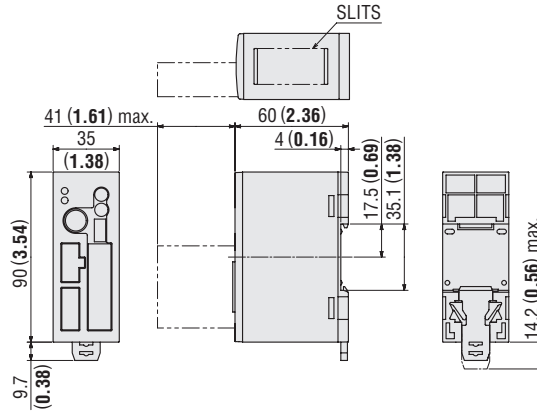

- Control I/O Connector (CN5)
Cover Assembly: 10336-52A0-008 (SUMITOMO 3M)
Connector: 10136-3000PE (SUMITOMO 3M)
- Connector for Power Supply Input/Frame Ground Terminal (CN1)
Connector: MC1.5/3-STF-3.5 (PHOENIX CONTACT)

● Connection Cables (Included)

● Cable for Motor

For AR24 and AR26

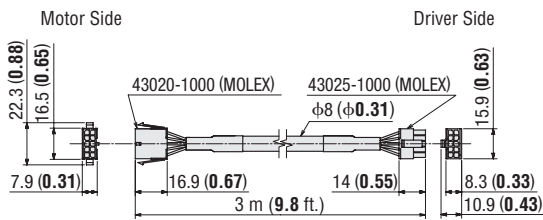

● Cable for Electromagnetic Brake (Only for electromagnetic brake type)

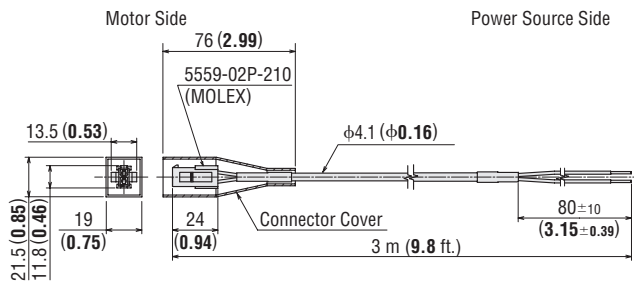

For AR46, AR66, AR69 and AR98

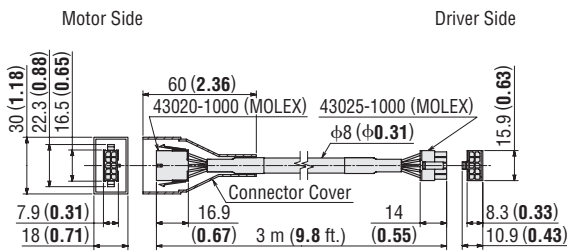

Connection and Operation

Names and Functions of Driver Parts

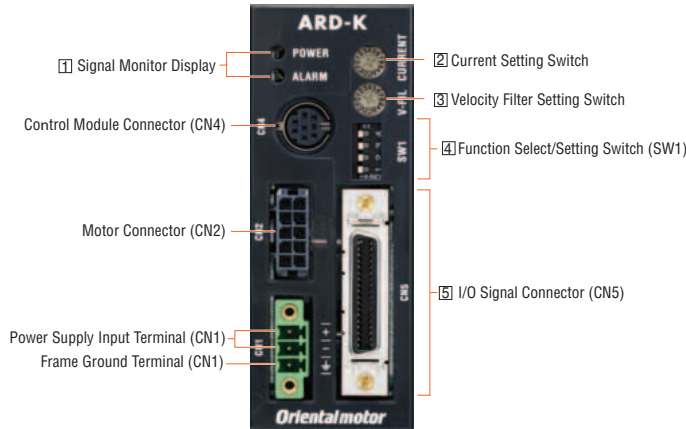

1 Signal Monitor Displays

◇ LED Displays

Indication	Color	Function	When Activated
POWER	Green	Power supply indication	Lights when power is on.
ALARM	Red	Alarm indication	Blinks when protective functions are activated.

◇ Alarms

Blink Count	Function	When Activated
2	Overheat	The temperature inside the driver rises above 85°C (185°F).
	Overload	When the amount of time during which the load torque exceeded the maximum torque exceeds the overload detection time. (Default value: 5 seconds)
	Overspeed	The motor output shaft speed exceeds 4500 r/min.
	Command pulse error	The command pulse value becomes abnormal.
3	Overvoltage	The primary voltage of the driver's inverter exceeds the upper limit.
	Undervoltage	The primary voltage of the driver's inverter drops below the lower limit.
4	Overflow rotation during current on	The position deviation exceeds the overflow revolutions. (Default value: 3 revolutions)
	Overflow rotation during current off	The current is turned on even though the position deviation when the current is turned off was equal to or greater than the permissible value. (Default value: 100 revolutions or more)
7	Abnormal operation data	Return to electrical home operation is performed while an operation data error warning is present.
	Electronic gear setting error	The resolution set by the electronic gear is outside the specified range.
	Sensor error during operation	A sensor error occurs while the motor is rotating.
8	Initial sensor error	The power source is turned on when the motor cable is not connected to the driver.
	Initial rotor rotation error	The main power is turned on while the motor is rotating.
	Motor combination error	A motor not supported by the driver is connected.
9	EEPROM error	A motor control parameter is damaged.

2 Current Setting Switch

Indication	Switch Name	Function
CURRENT	Current setting switch	This switch adjusts the operating current. It is used to limit the torque and temperature rise. A desired current can be set as a percentage (%) of the rated output current. The factory setting is "F".

3 Velocity Filter Setting Switch

Indication	Switch Name	Function
V-FIL	Velocity filter setting switch	<p>This switch adjusts the motor response. Adjust the switch if you want to suppress motor vibration or cause the motor to start/stop smoothly. "0" and "F" correspond to the minimum and maximum velocity filter settings, respectively. The factory setting is "1."</p> <p>The difference in characteristics made by the velocity filter</p>

Introduction	AC Input Motor & Driver	DC Input Motor & Driver	Motor Only	Controllers	Accessories
ARD	0.36° / Geared	0.36° / Geared	0.36°	SCX10	
AR	0.72° / Geared	0.36° / Geared	0.72°	EMP400	
AS	0.36° / Geared	0.36° / Geared	0.9°	5G8030J	
RK	0.72° / Geared	0.9° / Geared	1.8°		
UMK	0.9° / Geared	1.8° / Geared	1.8°		
AR	0.36° / Geared	0.36° / Geared	0.36°		
ASX	0.36° / Geared	0.36° / Geared	0.72°		
CRK	0.36° / Geared	0.36° / Geared	0.9°		
CMK	0.9° / Geared	0.36° / Geared	1.8°		
RBK	1.8° / Geared	0.36° / Geared	1.8°		
PK	0.36° / Geared	0.36° / Geared	0.36°		
PK	0.72° / Geared	0.36° / Geared	0.72°		
PK	0.9° / Geared	0.36° / Geared	0.9°		
PK/PV	1.8° / Geared	0.36° / Geared	1.8°		
PK	Geared	0.36° / Geared	Geared		

4 Function Select/Setting Switches

Indication	Switch Name	Function
4	Resolution select switches "D0/D1" "CS0/CS1"	These switches are used to set the resolution per rotation of the motor output shaft. "4:OFF" "3:OFF"→1000 pulse (0.36°/step) [Factory setting] "4:OFF" "3:ON"→10000 pulse (0.036°/step)
3		"4:ON" "3:OFF"→500 pulse (0.72°/step) "4:ON" "3:ON"→5000 pulse (0.072°/step)
2	Control mode select switches "NORM/CCM"	This switch toggles the driver between the normal mode and current control mode. In the current control mode, noise and vibration can be reduced although the motor synchronicity may reduce. "OFF": Normal mode [Factory setting] "ON": Current control mode
1	Pulse input mode switch "2P/1P"	The settings of this switch are compatible with the following two types of pulse input modes: "OFF": 2-pulse input mode "ON": 1-pulse input mode [Factory setting]

5 I/O Signal Connector (CN5, 36 pins)

Indication	Input/Output	Pin No.	Signal		Signal Name	
			Positioning Operation	Push-Motion Operation	Positioning Operation	Push-Motion Operation*1
CN5	—	1	—		—	
	Output	2	GND		Ground connection	
		3	ASG +		A-phase pulse output (line driver)	
		4	ASG -		A-phase pulse output (line driver)	
		5	BSG +		B-phase pulse output (line driver)	
		6	BSG -		B-phase pulse output (line driver)	
		7	TIM1 +		Timing output (line driver)	
		8	TIM1 -		Timing output (line driver)	
		9	ALM +		Alarm output	
		10	ALM -		Alarm output	
		11	WNG +		Warning output	
		12	WNG -		Warning output	
		13	END +		Positioning complete output	
		14	END -		Positioning complete output	
		15	READY + /AL0 +		Operation ready complete output/Alarm code output 0*1	
		16	READY - /AL0 -		Operation ready complete output/Alarm code output 0*1	
		17	TLC + /AL1 +		Torque limit output /Alarm code output 1*1	
		18	TLC - /AL1 -		Torque limit output /Alarm code output 1*1	
		19	TIM2 + /AL2 +		Timing output (open-collector)/Alarm code output 2*1	
		20	TIM2 - /AL2 -		Timing output (open-collector)/Alarm code output 2*1	
		21	GND		Ground connection	
	Input	22	IN-COM		Input signal common	
		23	C-ON		Current on input*2	
		24	CLR/ALM-RST		Deviation counter clear input/Alarm reset input	
		25	CCM		Current control mode ON input	
		26	CS	T-MODE	Resolution select input	Push-motion operation ON*1
		27	—	M0	—	—
		28	RETURN	M1	Return to electrical home operation	Push-current setting select input*1
		29	P-RESET	M2	Position reset input	Push-current setting select input*1
		30	FREE		Excitation OFF	
		31	PLS + /CW +		Pulse input/CW pulse input (+5 V/line driver)	
		32	PLS - /CW -		Pulse input/CW pulse input (+5 V/line driver)	
		33	PLS +24 /CW +24V		Pulse input/CW pulse input (+24V)	
		34	DIR +24 /CCW +24V		Direction input/CCW pulse input (+24V)	
		35	DIR + /CCW +		Direction input/CCW pulse input (+5 V/line driver)	
		36	DIR - /CCW -		Direction input/CCW pulse input (+5 V/line driver)	

*1 The signal will become effective if the applicable setting has been changed using the accessory control module **OPX-2A** or the data setting software **MEXE02** (both sold separately).

*2 The factory setting of the C-ON input is normally open. Be sure to turn the C-ON input ON when operating the motor.

Set the C-ON input to normally close with a control module (**OPX-2A**, sold separately) or a data setting software (**MEXE02**, sold separately) when the C-ON input is not used.

● Connection Diagram

◇ Connecting to a Host Controller

● Connecting to a Current Sink Output Circuit

When pulse input is of line driver type

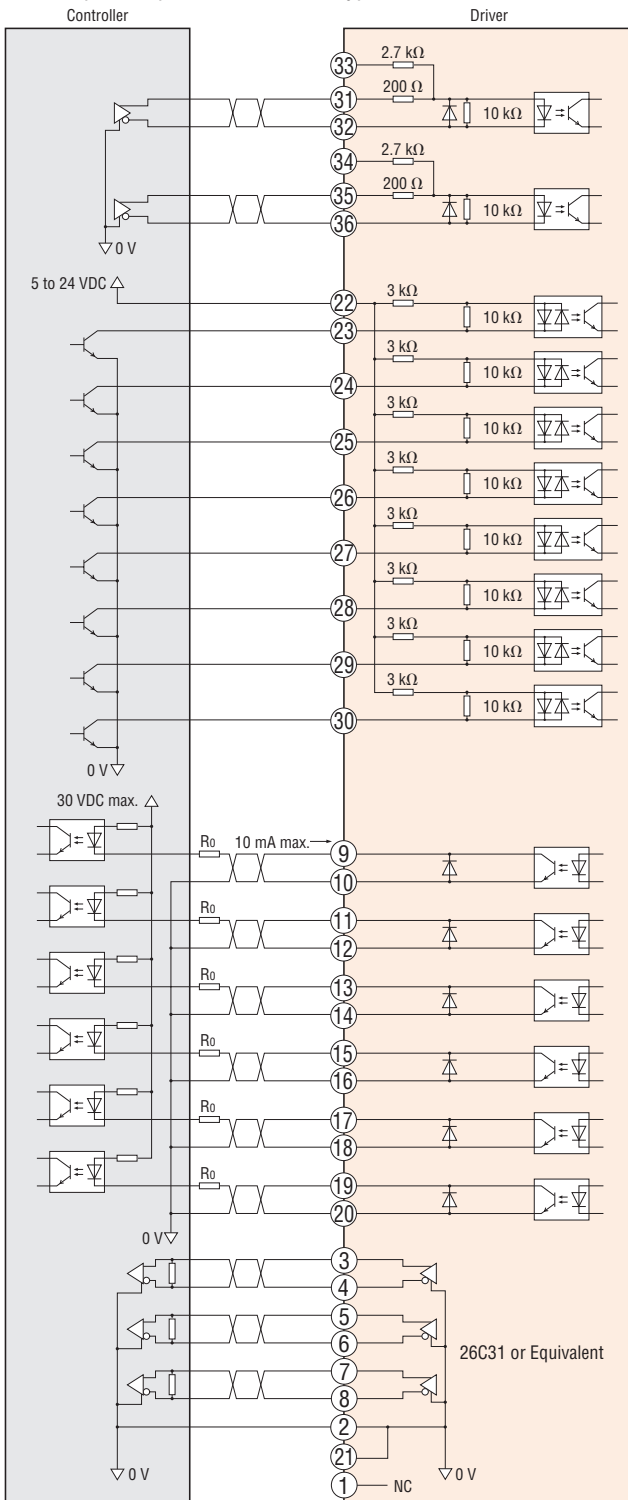

When pulse input is of 5 VDC type

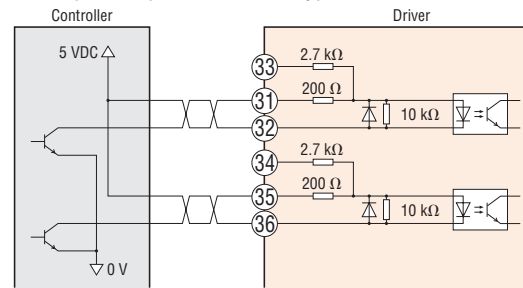

When pulse input is of 24 VDC type

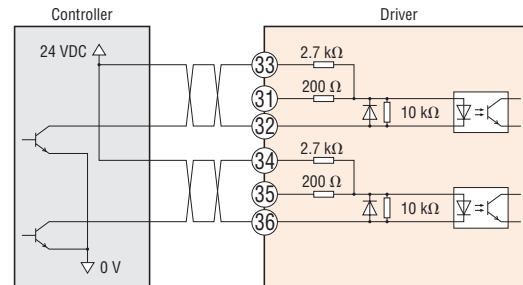

Notes

- Use output signals at 30 VDC or less. If the current exceeds 10 mA, connect an external resistor R_o .
- Connect a terminal resistor of 100 Ω or more between the input of the line receiver terminals.
- Use a multi-core, twisted-pair shielded wire of AWG28 to 24 for the control input/output signal line (CN5), and keep wiring as short as possible [within 2 m (6.6 ft.)].
- Note that as the length of the pulse signal line increases, the maximum transmission frequency decreases.
- Provide a minimum distance of 200 mm (7.9 in.) between the control I/O signal lines and power lines (AC lines, motor lines and other large-current circuits). Do not run the control I/O signal lines in the same duct as power lines or bundle them with power lines.

Introduction	
AR	AC Input Motor & Driver
AS	0.36° / Geared / 0.72° / Geared
ASX	0.36° / Geared / 0.72° / Geared
CRK	0.9° / 1.8° / Geared / 0.36° / Geared
CMK	0.36° / Geared / 0.72° / Geared
RBK	1.8° / Geared
PK	0.36°
PK	0.72°
PK	Motor Only
PK/PV	0.9°
PK	1.8°
PK	Geared
SCX10 / EMP400 / SG8030J	Controllers
	Accessories

◇ Connecting to a Host Controller

● Connecting to a Current Source Output Circuit

When pulse input is of line driver type

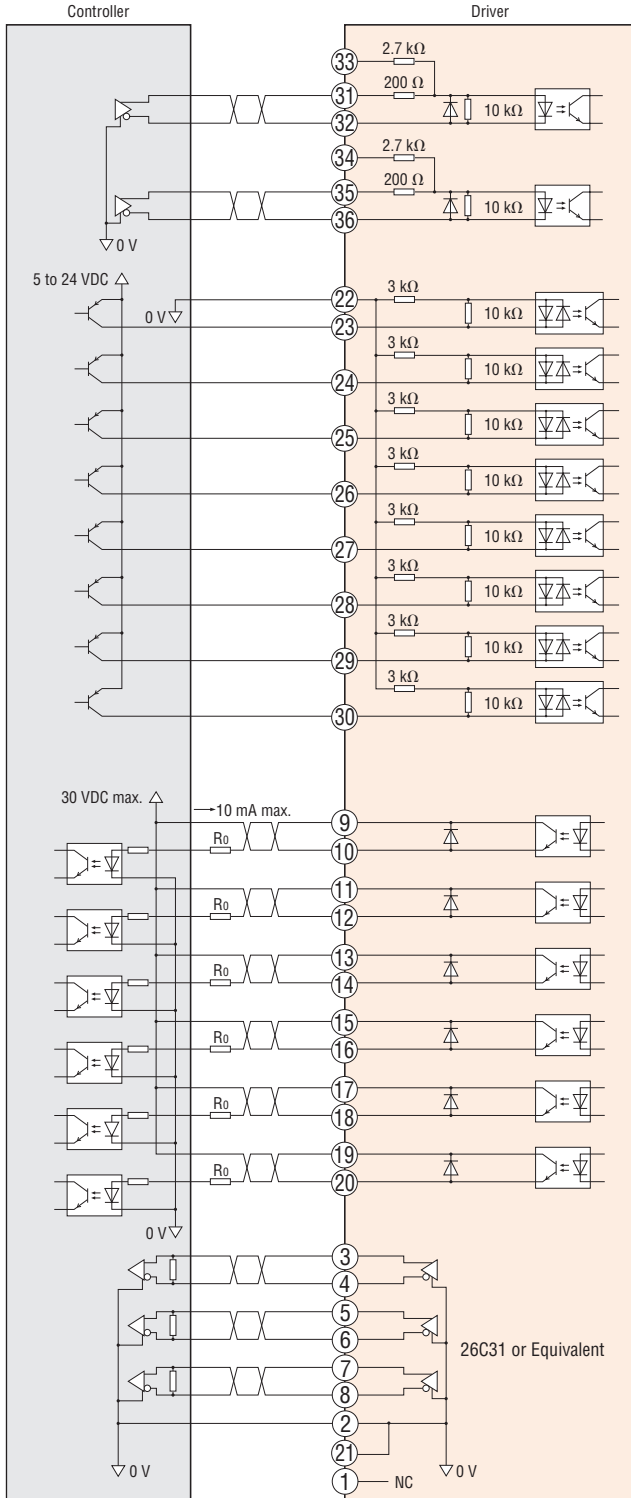

When pulse input is of 5 VDC type

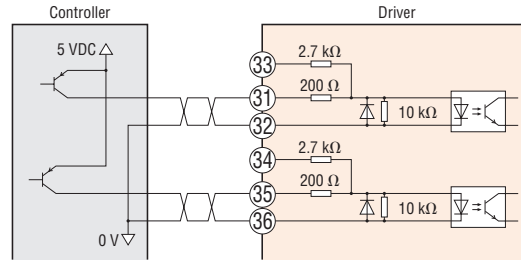

When pulse input is of 24 VDC type

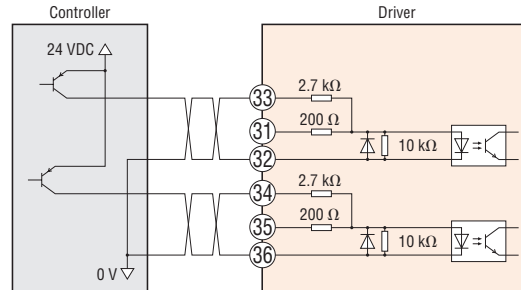

Notes

- Use output signals at 30 VDC or less. If the current exceeds 10 mA, connect an external resistor R_o .
- Connect a terminal resistor of 100 Ω or more between the input of the line receiver terminals.
- Use a multi-core, twisted-pair shielded wire of AWG28 to 24 for the control input/output signal line (CN5), and keep wiring as short as possible [within 2 m (6.6 ft.)].
- Note that as the length of the pulse signal line increases, the maximum transmission frequency decreases.
- Provide a minimum distance of 200 mm (7.9 in.) between the control I/O signal lines and power lines (AC lines, motor lines and other large-current circuits). Do not run the control I/O signal lines in the same duct as power lines or bundle them with power lines.

List of Motor and Driver Combinations

Model names for motor and driver combinations are shown below.

Type	Model	Motor Model	Driver Model		
Standard Type	AR245 <input type="checkbox"/> K-3 *1	ARM245S <input type="checkbox"/> K	ARD-K		
	AR265 <input type="checkbox"/> K-3 *1	ARM265S <input type="checkbox"/> K			
	AR46 <input type="checkbox"/> K-3 *2	ARM46 <input type="checkbox"/> K			
	AR66 <input type="checkbox"/> K-3 *2	ARM66 <input type="checkbox"/> K			
	AR69 <input type="checkbox"/> K-3 *2	ARM69 <input type="checkbox"/> K			
	AR98 <input type="checkbox"/> K-3 *2	ARM98 <input type="checkbox"/> K			
TH Geared Type	AR24SAK-T7.2-3	ARM24SAK-T7.2	ARD-K		
	AR24SAK-T10-3	ARM24SAK-T10			
	AR24SAK-T20-3	ARM24SAK-T20			
	AR24SAK-T30-3	ARM24SAK-T30			
	AR46 <input type="checkbox"/> K-T3.6-3	ARM46 <input type="checkbox"/> K-T3.6			
	AR46 <input type="checkbox"/> K-T7.2-3	ARM46 <input type="checkbox"/> K-T7.2			
	AR46 <input type="checkbox"/> K-T10-3	ARM46 <input type="checkbox"/> K-T10			
	AR46 <input type="checkbox"/> K-T20-3	ARM46 <input type="checkbox"/> K-T20			
	AR46 <input type="checkbox"/> K-T30-3	ARM46 <input type="checkbox"/> K-T30			
	AR66 <input type="checkbox"/> K-T3.6-3	ARM66 <input type="checkbox"/> K-T3.6			
	AR66 <input type="checkbox"/> K-T7.2-3	ARM66 <input type="checkbox"/> K-T7.2			
	AR66 <input type="checkbox"/> K-T10-3	ARM66 <input type="checkbox"/> K-T10			
	AR66 <input type="checkbox"/> K-T20-3	ARM66 <input type="checkbox"/> K-T20			
	AR66 <input type="checkbox"/> K-T30-3	ARM66 <input type="checkbox"/> K-T30			
	AR98 <input type="checkbox"/> K-T3.6-3	ARM98 <input type="checkbox"/> K-T3.6			
	AR98 <input type="checkbox"/> K-T7.2-3	ARM98 <input type="checkbox"/> K-T7.2			
	AR98 <input type="checkbox"/> K-T10-3	ARM98 <input type="checkbox"/> K-T10			
	AR98 <input type="checkbox"/> K-T20-3	ARM98 <input type="checkbox"/> K-T20			
	AR98 <input type="checkbox"/> K-T30-3	ARM98 <input type="checkbox"/> K-T30			
	PS Geared Type	AR24SAK-PS5-3		ARM24SAK-PS5	ARD-K
		AR24SAK-PS7-3		ARM24SAK-PS7	
AR24SAK-PS10-3		ARM24SAK-PS10			
AR46 <input type="checkbox"/> K-PS5-3		ARM46 <input type="checkbox"/> K-PS5			
AR46 <input type="checkbox"/> K-PS7-3		ARM46 <input type="checkbox"/> K-PS7			
AR46 <input type="checkbox"/> K-PS10-3		ARM46 <input type="checkbox"/> K-PS10			
AR46 <input type="checkbox"/> K-PS25-3		ARM46 <input type="checkbox"/> K-PS25			
AR46 <input type="checkbox"/> K-PS36-3		ARM46 <input type="checkbox"/> K-PS36			
AR46 <input type="checkbox"/> K-PS50-3		ARM46 <input type="checkbox"/> K-PS50			
AR66 <input type="checkbox"/> K-PS5-3		ARM66 <input type="checkbox"/> K-PS5			
AR66 <input type="checkbox"/> K-PS7-3		ARM66 <input type="checkbox"/> K-PS7			
AR66 <input type="checkbox"/> K-PS10-3		ARM66 <input type="checkbox"/> K-PS10			
AR66 <input type="checkbox"/> K-PS25-3		ARM66 <input type="checkbox"/> K-PS25			
AR66 <input type="checkbox"/> K-PS36-3		ARM66 <input type="checkbox"/> K-PS36			
AR66 <input type="checkbox"/> K-PS50-3		ARM66 <input type="checkbox"/> K-PS50			
AR98 <input type="checkbox"/> K-PS5-3		ARM98 <input type="checkbox"/> K-PS5			
AR98 <input type="checkbox"/> K-PS7-3		ARM98 <input type="checkbox"/> K-PS7			
AR98 <input type="checkbox"/> K-PS10-3		ARM98 <input type="checkbox"/> K-PS10			
AR98 <input type="checkbox"/> K-PS25-3		ARM98 <input type="checkbox"/> K-PS25			
AR98 <input type="checkbox"/> K-PS36-3		ARM98 <input type="checkbox"/> K-PS36			
AR98 <input type="checkbox"/> K-PS50-3		ARM98 <input type="checkbox"/> K-PS50			

● Enter **A** (single shaft) or **M** (electromagnetic brake) in the box () within the model name.

*1 Enter **A** (single shaft) or **B** (double shaft) in the box () within the model names of **AR245** **K-3** and **AR26** **K-3**.

*2 Enter **A** (single shaft), **B** (double shaft) or **M** (electromagnetic brake) in the box () within the model names of **AR46** **K-3**, **AR66** **K-3**, **AR69** **K-3** and **AR98** **K-3**.

Type	Model	Motor Model	Driver Model
PN Geared Type	AR24SAK-N5-3	ARM24SAK-N5	ARD-K
	AR24SAK-N7.2-3	ARM24SAK-N7.2	
	AR24SAK-N10-3	ARM24SAK-N10	
	AR46 <input type="checkbox"/> K-N5-3	ARM46 <input type="checkbox"/> K-N5	
	AR46 <input type="checkbox"/> K-N7.2-3	ARM46 <input type="checkbox"/> K-N7.2	
	AR46 <input type="checkbox"/> K-N10-3	ARM46 <input type="checkbox"/> K-N10	
	AR66 <input type="checkbox"/> K-N5-3	ARM66 <input type="checkbox"/> K-N5	
	AR66 <input type="checkbox"/> K-N7.2-3	ARM66 <input type="checkbox"/> K-N7.2	
	AR66 <input type="checkbox"/> K-N10-3	ARM66 <input type="checkbox"/> K-N10	
	AR66 <input type="checkbox"/> K-N25-3	ARM66 <input type="checkbox"/> K-N25	
	AR66 <input type="checkbox"/> K-N36-3	ARM66 <input type="checkbox"/> K-N36	
	AR66 <input type="checkbox"/> K-N50-3	ARM66 <input type="checkbox"/> K-N50	
	AR98 <input type="checkbox"/> K-N5-3	ARM98 <input type="checkbox"/> K-N5	
	AR98 <input type="checkbox"/> K-N7.2-3	ARM98 <input type="checkbox"/> K-N7.2	
	AR98 <input type="checkbox"/> K-N10-3	ARM98 <input type="checkbox"/> K-N10	
Harmonic Geared Type	AR98 <input type="checkbox"/> K-N25-3	ARM98 <input type="checkbox"/> K-N25	ARD-K
	AR98 <input type="checkbox"/> K-N36-3	ARM98 <input type="checkbox"/> K-N36	
	AR98 <input type="checkbox"/> K-N50-3	ARM98 <input type="checkbox"/> K-N50	
	AR24SAK-H50-3	ARM24SAK-H50	
	AR24SAK-H100-3	ARM24SAK-H100	
	AR46 <input type="checkbox"/> K-H50-3	ARM46 <input type="checkbox"/> K-H50	
	AR46 <input type="checkbox"/> K-H100-3	ARM46 <input type="checkbox"/> K-H100	
	AR66 <input type="checkbox"/> K-H50-3	ARM66 <input type="checkbox"/> K-H50	
	AR66 <input type="checkbox"/> K-H100-3	ARM66 <input type="checkbox"/> K-H100	
	AR98 <input type="checkbox"/> K-H50-3	ARM98 <input type="checkbox"/> K-H50	
AR98 <input type="checkbox"/> K-H100-3	ARM98 <input type="checkbox"/> K-H100		

Introduction
AC Input Motor & Driver
AR ^{OSTEP} / Geared 0.36°
AS ^{OSTEP} / Geared 0.72°
RK / Geared 0.9°/1.8°
UMK / Geared 0.9°/1.8°
DC Input Motor & Driver
AR ^{OSTEP} / Geared 0.36°
ASX ^{OSTEP} / Geared 0.36°
CRK / Geared 0.36°/0.72°
CMK / Geared 0.9°/1.8°
RBK / Geared 1.8°
Motor Only
PK 0.36°
PK 0.72°
PK 0.9°
PK/PV 1.8°
Geared PK
Controllers SCL10 EMP400 /SG8030J
Accessories

Extended Functions

With the accessory control module **OPX-2A** or data setting software **MEXE02** (both sold separately), extended functions of the **AR** Series are available. You can change the internal parameters of the driver, perform test operations and monitor the operation.



Control Module (**OPX-2A**)
→ Page A-430

Data Setting Software (**MEXE02**)
→ Page A-431

Parameter Setting

You can set the advanced settings of the signals and change the generation conditions of the alarm.

Application Parameter	Operating current	Current value assigned to the operating current setting switch	
	Speed filter	Filter time constant assigned to the speed filter setting switch	
	I/O	Input signal mode	Positioning operation/push-motion operation switching
		Alarm code signal enabled/disabled	
		C-ON input logic	
		Output condition for END signal (output width)	
	Normal mode	Current value applicable to push-motion operation	
		Standstill current in the normal mode	
	Current control mode	Speed difference gain in the normal mode	
		Position loop gain in the current control mode	
		Speed loop gain in the current control mode	
		Speed loop integral time constant in the current control mode	
	Alarm/Warning	Damping control enabled/disabled in the current control mode	
		Damping control vibration frequency in the current control mode	
		Operation data error warning enabled/disabled	
Generation condition of overflow rotation alarm during current on			
Generation condition of overflow rotation alarm during current off			
Generation condition of overload alarm			
Generation condition of overflow rotation warning			
Generation condition of overvoltage warning			
Return to electrical home operation	Generation condition of undervoltage warning		
	Generation condition of overheat warning		
	Generation condition of overload warning		
Manual operation	Generation condition of overspeed warning		
	Operating speed for return to electrical home operation		
	Acceleration/deceleration rate for return to electrical home operation		
Control module	Starting speed for return to electrical home operation		
	Operating speed for test operation		
Electronic gear	Acceleration/deceleration rate for test operation		
	Starting speed for test operation		
System Parameter (Becomes effective after the power is cycled)	Control module	Speed monitor display. Show the speed on the control module with a sign or as an absolute value Gear ratio for geared motor used for speed monitor	
	Operation setting	Resolution assigned to each resolution switch	
		Pulse input mode	
		Smooth drive enabled/disabled	
	Initial motor excitation position at power ON. Detected position/electrical angle 0° switching		
	Automatic return operation at current ON enabled/disabled		
	Motor rotation direction		

Monitoring

You can monitor various signals, alarms and motor speeds/positions, and also perform test operations.

Monitoring	Monitor positions
	Monitor speeds
	Monitor I/Os
Waveform monitoring*	Monitor positions*
	Monitor speeds*
	Measure waveforms*
	Save waveforms*
Test	Perform test operation (JOG operation)
	Monitor conditions during test operation
	Perform return to electrical home operation
	Forcibly turn output signals ON/OFF
Alarm	Check information on alarms that generated
	Check alarm history (10 most recent alarms)
	Clear alarm history
Warning	Cancel
	Check information on warnings that generated
	Check warning history (10 most recent warnings)
	Clear warning history

◇ Waveform Monitoring

You can monitor various signals and motor speeds/positions using waveforms.

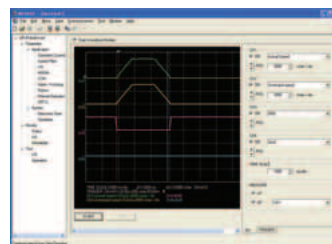

● Other

- Electrical home reset
- Parameter initialization

*This function is available only when the data setting software (**MEXE02**) is used.

Introduction	AC Input Motor & Driver		DC Input Motor & Driver		Motor Only				Controllers	Accessories				
	0.36° / Geared / <i>AR</i>	0.72° / Geared / <i>AS</i>	0.36° / Geared / <i>AR</i>	0.36° / Geared / <i>ASX</i>	0.36° / Geared / <i>CRK</i>	0.9° / Geared / <i>CMK</i>	1.8° / Geared / <i>RBK</i>	0.36° / <i>PK</i>	0.72° / <i>PK</i>	0.9° / <i>PK</i>	1.8° / <i>PK/PV</i>	Geared / <i>PK</i>	<i>SCX10</i> / <i>EMP400</i> / <i>SG8030J</i>	