

0.9°/1.8° Stepping Motor and Driver Package CMK Series

● Additional Information ●
Technical reference → Page G-1

RoHS

The **CMK** Series is a motor and driver package consisting of a 0.9°/1.8° Stepping Motor and a compact 24 VDC input microstep driver, allowing for a reduction in the size of your equipment and in vibration.

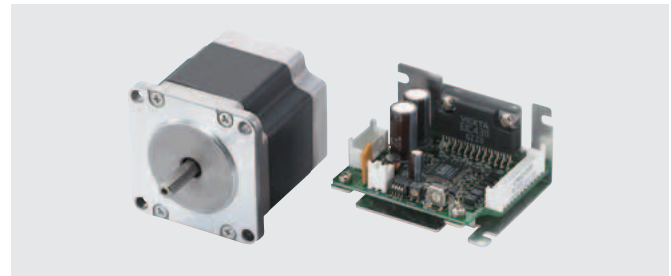

Features

● Achieving Low Vibration and Noise in a Microstep Drive

The newly designed DC board-level microstepping driver is compact and lightweight. The 1.8° stepping motor's basic step angle (1.8°/step) is divided by a maximum of 16 resolutions (0.1125°/step) without the use of a reduction mechanism or other mechanical elements, which contributes to the reduction in noise and vibration of your equipment.

Microsteps/Step	Resolution	Step Angle
1	200	1.8°
2	400	0.9°
4	800	0.45°
8	1600	0.225°
16	3200	0.1125°

(At basic step angle of 1.8°/step)

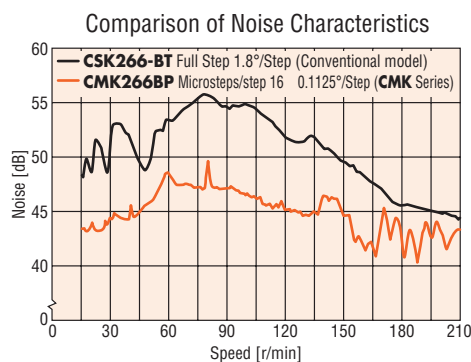
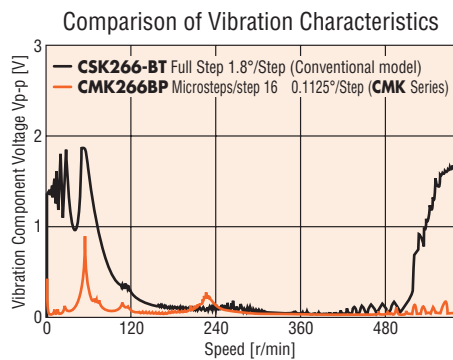

● Full Range of Driver Functions

- Five preset step angles
- Operating current can easily be set with a digital switch
- 1-pulse/2-pulse input mode switching
- Power LED
- Connector with lock (by MOLEX)

● One of the Smallest Microstep Drivers in the Industry

The **CMK** Series driver is one of the smallest, lightest microstep drivers in the industry. The driver is 62% lighter and has 41% less install area (based on horizontal installation) compared to our conventional model. This product contributes to downsizing of your equipment.

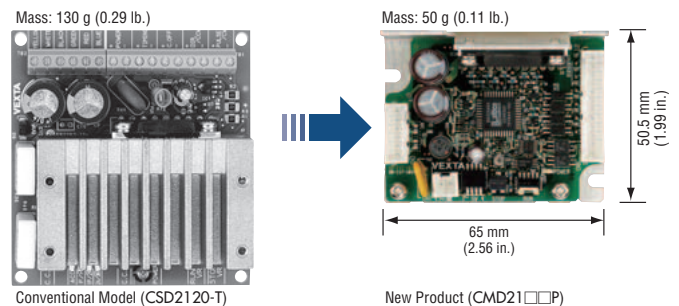

Comparison with a conventional driver

- ◇ Mass: **62%** less
- ◇ Install area: **41%** less (based on horizontal installation)
- ◇ Volume: **41%** less [the conventional driver includes a 5 mm (0.2 in.) spacer for installation.]
- ◇ Easy-to-Install Heat Sink Shape



Horizontal Installation



Vertical Installation

System Configuration

An example of a system configuration with the **SG8030J** controller.

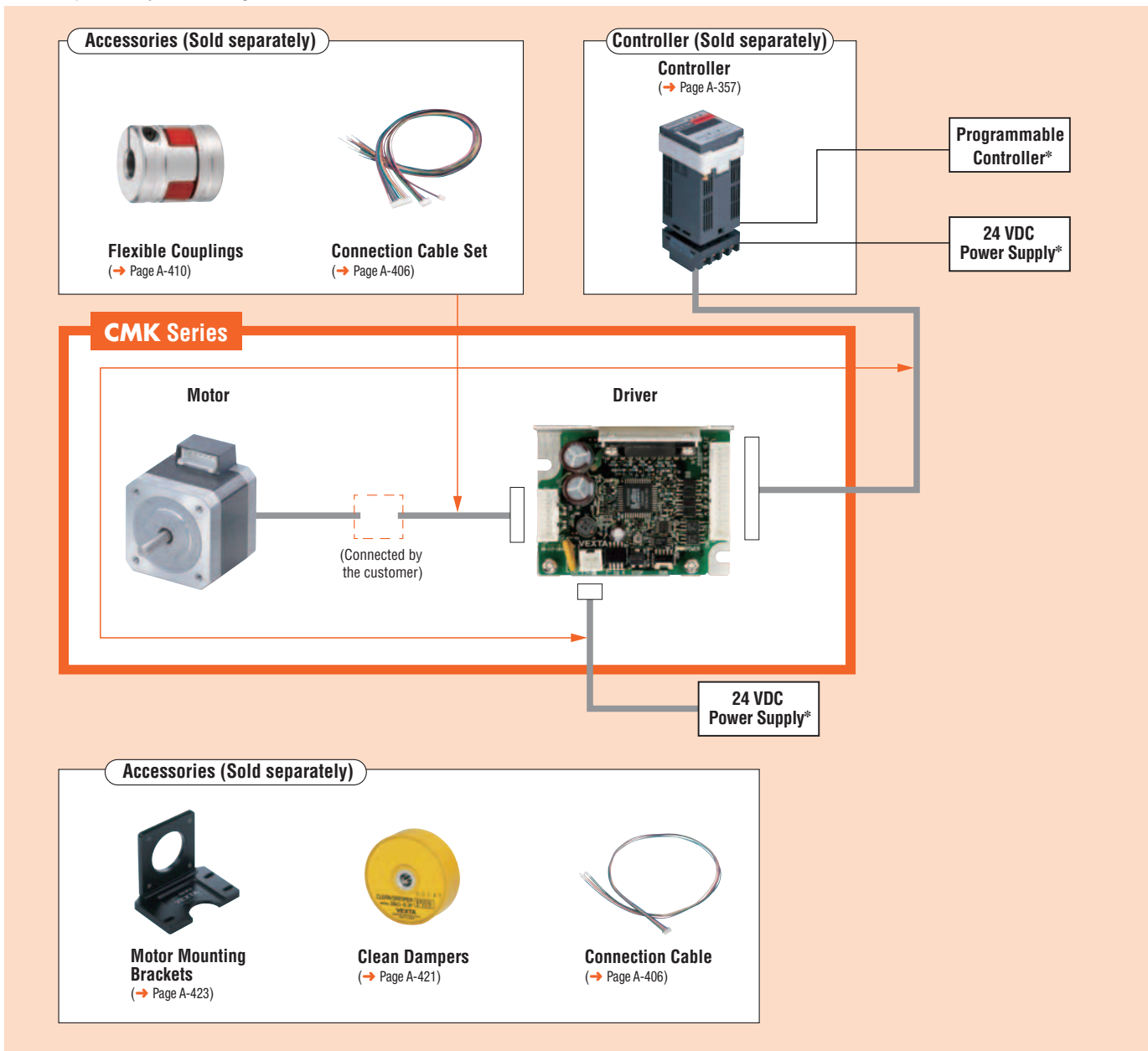

Example of System Configuration

CMK Series	Sold Separately				
	Controller	Motor Mounting Bracket	Flexible Coupling	Clean Damper	Connection Cable Set [0.6 m (2 ft.)]
CMK244BPB	SG8030J-U	PALOPA	MCS140506	D4CL-5.0F	LCS01CMK2

● The system configuration shown above is an example. Other combinations are available.

* Not supplied

Product Number Code

Standard Type, High-Torque Type

CMK 2 4 3 M A P A

① ② ③ ④ ⑤ ⑥ ⑦ ⑧

Standard Type, High-Torque Type with Encoder

CMK 2 4 3 M A P A - R 1 5

① ② ③ ④ ⑤ ⑥ ⑦ ⑧ ⑨ ⑩ ⑪

SH Geared Type

CMK 2 6 4 A P A-SG 10

① ② ③ ④ ⑤ ⑥ ⑦ ⑧ ⑨

SH Geared Type with Encoder

CMK 2 4 3 P A R 1 5 S 10

① ② ③ ④ ⑤ ⑥ ⑦ ⑧ ⑨ ⑩ ⑪

①	Series	CMK: CMK Series
②	2: 2-Phase	
③	Motor Frame Size	2: 28 mm (1.10 in.) 3: 35 mm (1.38 in.) 4: 42 mm (1.65 in.) 5: 50 mm (1.97 in.) 6: 56.4 mm (2.22 in.)
④	Motor Case Length	
⑤	Motor Type	P: Step Angle 1.8° High-Torque Type M: Step Angle 0.9° Standard Type Blank: Step Angle 1.8° Standard Type
⑥	Shaft Type	A: Single Shaft B: Double Shaft
⑦	Signal I/O Mode of Driver	P: Photocoupler
⑧	U.S.A. Version	

①	Series	CMK: CMK Series
②	2: 2-Phase	
③	Motor Frame Size	2: 28 mm (1.10 in.) 3: 35 mm (1.38 in.) 4: 42 mm (1.65 in.) 5: 50 mm (1.97 in.) 6: 56.4 mm (2.22 in.)
④	Motor Case Length	
⑤	Motor Type	P: Step Angle 1.8° High-Torque Type M: Step Angle 0.9° Standard Type Blank: Step Angle 1.8° Standard Type
⑥	Shaft Type	A: Single Shaft
⑦	Signal I/O Mode of Driver	P: Photocoupler
⑧	U.S.A. Version	
⑨	Encoder Version	
⑩	Encoder Output	1: 2-Channel A, B 2: 3-Channel A, B, I
⑪	Encoder Resolution	5: 200P/R 6: 400P/R

①	Series	CMK: CMK Series
②	2: 2-Phase	
③	Motor Frame Size	2: 28 mm (1.10 in.) 4: 42 mm (1.65 in.) 6: 60 mm (2.36 in.)
④	Motor Case Length	
⑤	Shaft Type	A: Single Shaft B: Double Shaft
⑥	Signal I/O Mode of Driver	P: Photocoupler
⑦	U.S.A. Version	
⑧	Gearhead Type	SG: SH Geared Type
⑨	Gear Ratio	

①	Series	CMK: CMK Series
②	2: 2-Phase	
③	Motor Frame Size	2: 28 mm (1.10 in.) 4: 42 mm (1.65 in.) 6: 60 mm (2.36 in.)
④	Motor Case Length	
⑤	Signal I/O Mode of Driver	P: Photocoupler
⑥	U.S.A. Version	
⑦	Encoder Version	
⑧	Encoder Output	1: 2-Channel A, B 2: 3-Channel A, B, I
⑨	Encoder Resolution	5: 200P/R 6: 400P/R
⑩	Gearhead Type	S: SH Geared Type
⑪	Gear Ratio	

Introduction	
AC Input Motor & Driver	0.36° / Geared / AS
DC Input Motor & Driver	0.72° / Geared / RK
DC Input Motor & Driver	0.9° / 1.8° / Geared / UMK
DC Input Motor & Driver	0.36° / Geared / AR
DC Input Motor & Driver	0.36° / Geared / ASX
DC Input Motor & Driver	0.36° / Geared / Geared / CRK
DC Input Motor & Driver	0.9° / 1.8° / Geared / Geared / CMK
DC Input Motor & Driver	1.8° / Geared / RBK
Motor Only	0.36° / PK
Motor Only	0.72° / PK
Motor Only	0.9° / PK
Motor Only	1.8° / PK / PV
Motor Only	Geared / PK
Controllers	SCX10 / EMP400 / SG8030J
Accessories	

Product Line

● Step Angle 0.9° Standard Type

Model (Single shaft)	Model (Double shaft)
CMK243MAPA	CMK243MBPA
CMK244MAPA	CMK244MBPA
CMK245MAPA	CMK245MBPA
CMK264MAP	CMK264MBP
CMK266MAP	CMK266MBP
CMK268MAP	CMK268MBP

● Step Angle 1.8° High-Torque Type

Model (Single shaft)	Model (Double shaft)
CMK223PAP	CMK223PBP
CMK224PAP	CMK224PBP
CMK225PAP	CMK225PBP
CMK233PAP	CMK233PBP
CMK235PAP	CMK235PBP
CMK244PAP	CMK244PBP
CMK246PAP	CMK246PBP
CMK264PAPA	CMK264PBPA
CMK266PAPA	CMK266PBPA
CMK268PAPA	CMK268PBPA

● Step Angle 1.8° Standard Type

Model (Single shaft)	Model (Double shaft)
CMK243APA	CMK243BPA
CMK244APA	CMK244BPA
CMK245APA	CMK245BPA
CMK256AP	CMK256BP
CMK258AP	CMK258BP
CMK264AP	CMK264BP
CMK266AP	CMK266BP
CMK268AP	CMK268BP

The following items are included each product.
Motor, Driver, Driver Connector, Connection Cable*,
Operating Manual

* Only for Step Angle 1.8° High-Torque Type

● Step Angle 0.9° Standard Type with Encoder

Model	
CMK243MAPA-R15	CMK243MAPA-R16
CMK243MAPA-R25	CMK243MAPA-R26
CMK244MAPA-R15	CMK244MAPA-R16
CMK244MAPA-R25	CMK244MAPA-R26
CMK245MAPA-R15	CMK245MAPA-R16
CMK245MAPA-R25	CMK245MAPA-R26
CMK264MAP-R15	CMK264MAP-R16
CMK264MAP-R25	CMK264MAP-R26
CMK266MAP-R15	CMK266MAP-R16
CMK266MAP-R25	CMK266MAP-R26
CMK268MAP-R15	CMK268MAP-R16
CMK268MAP-R25	CMK268MAP-R26

● Step Angle 1.8° High-Torque Type with Encoder

Model	
CMK223PAP-R15	—
CMK224PAP-R15	—
CMK225PAP-R15	—
CMK233PAP-R15	CMK233PAP-R16
CMK233PAP-R25	CMK233PAP-R26
CMK235PAP-R15	CMK235PAP-R16
CMK235PAP-R25	CMK235PAP-R26
CMK244PAP-R15	CMK244PAP-R16
CMK244PAP-R25	CMK244PAP-R26
CMK246PAP-R15	CMK246PAP-R16
CMK246PAP-R25	CMK246PAP-R26
CMK264PAPA-R15	CMK264PAPA-R16
CMK264PAPA-R25	CMK264PAPA-R26
CMK266PAPA-R15	CMK266PAPA-R16
CMK266PAPA-R25	CMK266PAPA-R26
CMK268PAPA-R15	CMK268PAPA-R16
CMK268PAPA-R25	CMK268PAPA-R26

● Step Angle 1.8° Standard Type with Encoder

Model	
CMK243APA-R15	CMK243APA-R16
CMK243APA-R25	CMK243APA-R26
CMK244APA-R15	CMK244APA-R16
CMK244APA-R25	CMK244APA-R26
CMK245APA-R15	CMK245APA-R16
CMK245APA-R25	CMK245APA-R26
CMK256AP-R15	CMK256AP-R16
CMK256AP-R25	CMK256AP-R26
CMK258AP-R15	CMK258AP-R16
CMK258AP-R25	CMK258AP-R26
CMK264AP-R15	CMK264AP-R16
CMK264AP-R25	CMK264AP-R26
CMK266AP-R15	CMK266AP-R16
CMK266AP-R25	CMK266AP-R26
CMK268AP-R15	CMK268AP-R16
CMK268AP-R25	CMK268AP-R26

● SH Geared Type

Model (Single shaft)	Model (Double shaft)
CMK223AP-SG7.2	CMK223BP-SG7.2
CMK223AP-SG9	CMK223BP-SG9
CMK223AP-SG10	CMK223BP-SG10
CMK223AP-SG18	CMK223BP-SG18
CMK223AP-SG36	CMK223BP-SG36
CMK243APA-SG3.6	CMK243BPA-SG3.6
CMK243APA-SG7.2	CMK243BPA-SG7.2
CMK243APA-SG9	CMK243BPA-SG9
CMK243APA-SG10	CMK243BPA-SG10
CMK243APA-SG18	CMK243BPA-SG18
CMK243APA-SG36	CMK243BPA-SG36
CMK264APA-SG3.6	CMK264BPA-SG3.6
CMK264APA-SG7.2	CMK264BPA-SG7.2
CMK264APA-SG9	CMK264BPA-SG9
CMK264APA-SG10	CMK264BPA-SG10
CMK264APA-SG18	CMK264BPA-SG18
CMK264APA-SG36	CMK264BPA-SG36

The following items are included each product.
 Motor, Driver, Driver Connector, Connection Cable*,
 Mounting Screws for Motor, Operating Manual
 * Only for connector-coupled motor

● SH Geared Type with Encoder

Model	
CMK223PR15S7.2	-
CMK223PR15S9	-
CMK223PR15S10	-
CMK223PR15S18	-
CMK223PR15S36	-
CMK243PAR15S3.6	CMK243PAR16S3.6
CMK243PAR25S3.6	CMK243PAR26S3.6
CMK243PAR15S7.2	CMK243PAR16S7.2
CMK243PAR25S7.2	CMK243PAR26S7.2
CMK243PAR15S9	CMK243PAR16S9
CMK243PAR25S9	CMK243PAR26S9
CMK243PAR15S10	CMK243PAR16S10
CMK243PAR25S10	CMK243PAR26S10
CMK243PAR15S18	CMK243PAR16S18
CMK243PAR25S18	CMK243PAR26S18
CMK243PAR15S36	CMK243PAR16S36
CMK243PAR25S36	CMK243PAR26S36
CMK264PAR15S3.6	CMK264PAR16S3.6
CMK264PAR25S3.6	CMK264PAR26S3.6
CMK264PAR15S7.2	CMK264PAR16S7.2
CMK264PAR25S7.2	CMK264PAR26S7.2
CMK264PAR15S9	CMK264PAR16S9
CMK264PAR25S9	CMK264PAR26S9
CMK264PAR15S10	CMK264PAR16S10
CMK264PAR25S10	CMK264PAR26S10
CMK264PAR15S18	CMK264PAR16S18
CMK264PAR25S18	CMK264PAR26S18
CMK264PAR15S36	CMK264PAR16S36
CMK264PAR25S36	CMK264PAR26S36

Introduction	AC Input Motor & Driver	DC Input Motor & Driver	Motor Only	Controllers	Accessories
AR	0.36° / Geared DSTEP	ASX	0.36°	SCX10	
AS	0.72° / Geared DSTEP	CRK	0.72°	EMP400	
RK	0.9° / Geared	CMK	0.9°	SG8030J	
UMK	0.9°/1.8° / Geared	RBK	1.8°		
AR	0.36° / Geared DSTEP	PK	0.36°		
ASX	0.36° / Geared DSTEP	PK	0.72°		
CRK	0.36°/0.72° / Geared	PK	1.8°		
CMK	0.9°/1.8° / Geared	PK/PV	1.8°		
RBK	1.8° / Geared	PK	Geared		
PK	0.36°				
PK	0.72°				
PK	0.9°				
PK/PV	1.8°				
PK	Geared				

Step Angle 0.9° Motor Frame Size 42 mm (1.65 in.), 56.4 mm (2.22 in.) Standard Type

Specifications **RoHS**

Model	Single Shaft	CMK243MAPA	CMK244MAPA	CMK245MAPA	CMK264MAP	CMK266MAP	CMK268MAP
	Double Shaft	CMK243MBPA	CMK244MBPA	CMK245MBPA	CMK264MBP	CMK266MBP	CMK268MBP
	With Encoder	CMK243MAPA-R	CMK244MAPA-R	CMK245MAPA-R	CMK264MAP-R	CMK266MAP-R	CMK268MAP-R
Maximum Holding Torque	N·m (oz·in)	0.16 (22)	0.26 (36)	0.32 (45)	0.37 (52)	0.9 (127)	1.35 (191)
Holding Torque at Motor Standstill	Power ON N·m (oz·in)	0.064 (9.0)	0.1 (14.2)	0.12 (17.0)	0.14 (19.8)	0.36 (51)	0.54 (76)
Rotor Inertia	J: kg·m ² (oz·in ²)	35×10 ⁻⁷ (0.191)	54×10 ⁻⁷ (0.3)	68×10 ⁻⁷ (0.37)	120×10 ⁻⁷ (0.66)	300×10 ⁻⁷ (1.64)	480×10 ⁻⁷ (2.6)
Rated Current	A/Phase	0.95	1.2		2		
Basic Step Angle		0.9°					
Power Source		24 VDC±10% 1.5 A	24 VDC±10% 1.7 A		24 VDC±10% 2.9 A		
Excitation Mode		Microstep					

● Enter the encoder code (**15**, **16**, **25** or **26**) in the box (■) within the model name.

Speed – Torque Characteristics

CMK243

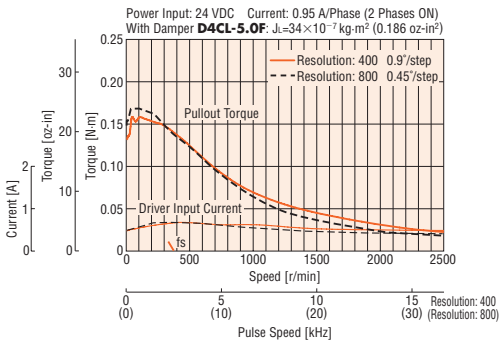

CMK244

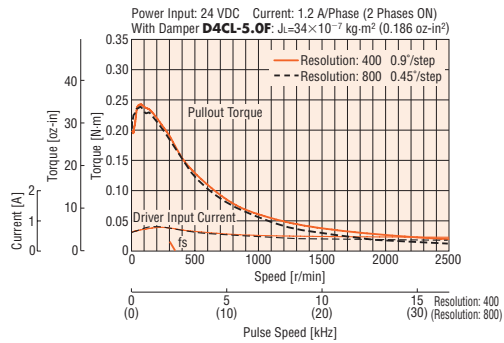

CMK245

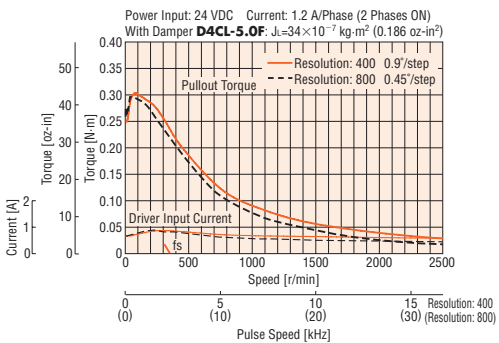

CMK264

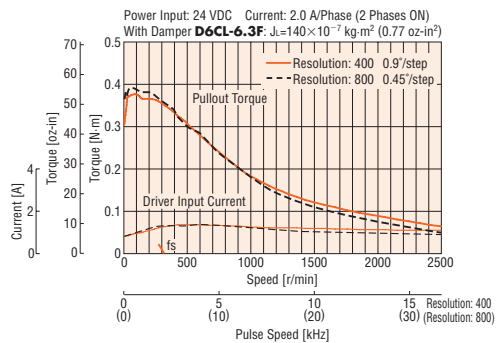

CMK266

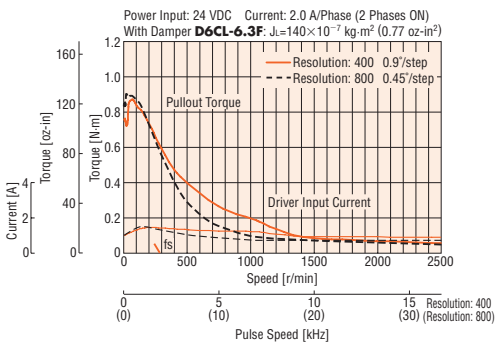

CMK268

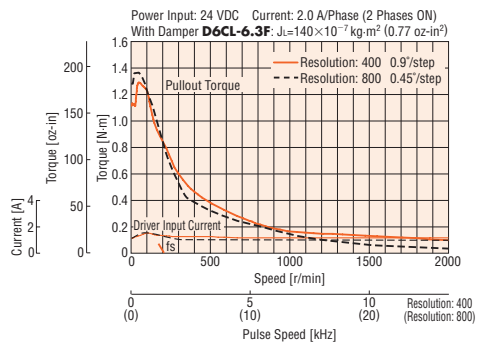

● The pulse input circuit responds to approximately 100 kHz with a pulse duty of 50%.

Note

● Pay attention to heat dissipation from the motor as there will be a considerable amount of heat under certain conditions. Be sure to keep the temperature of the motor case under 100°C (212°F).

Step Angle 1.8° Motor Frame Size 28 mm (1.10 in.)

High-Torque Type

Specifications RoHS

Model	Single Shaft	CMK223PAP	CMK224PAP	CMK225PAP
	Double Shaft	CMK223PBP	CMK224PBP	CMK225PBP
	With Encoder	CMK223PAP-R15	CMK224PAP-R15	CMK225PAP-R15
Maximum Holding Torque	N·m (oz·in)	0.05 (7.1)	0.075 (10.6)	0.09 (12.7)
Holding Torque at Motor Standstill	Power ON N·m (oz·in)	0.02 (2.8)	0.03 (4.2)	0.036 (5.1)
Rotor Inertia	J: kg·m ² (oz·in ²)	9×10 ⁻⁷ (0.049)	12×10 ⁻⁷ (0.066)	18×10 ⁻⁷ (0.098)
Rated Current	A/Phase	0.95		
Basic Step Angle		1.8°		
Power Source		24 VDC ±10% 1.5 A		
Excitation Mode		Microstep		

● A connection cable [0.6 m (2 ft.)] is included with the connector-coupled motor and driver package.

Speed – Torque Characteristics

CMK223

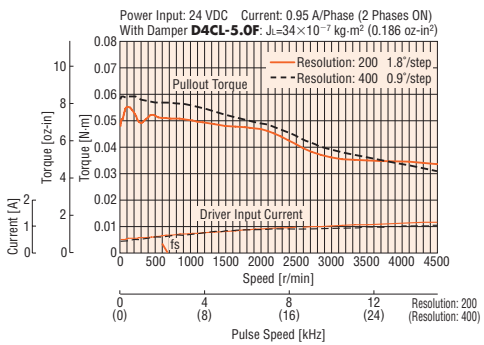

CMK224

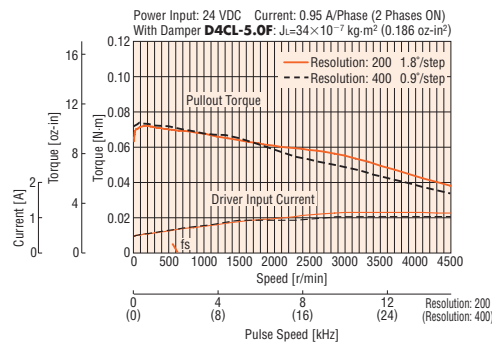

CMK225

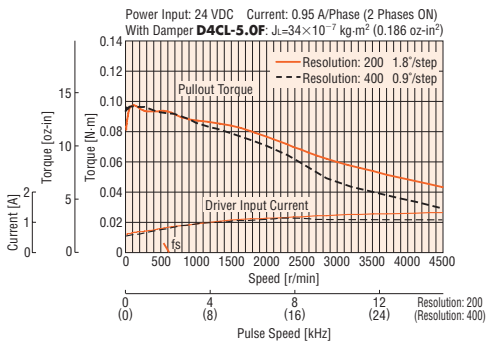

● The pulse input circuit responds to approximately 100 kHz with a pulse duty of 50%.

Note

● Pay attention to heat dissipation from the motor as there will be a considerable amount of heat under certain conditions. Be sure to keep the temperature of the motor case under 100°C (212°F).

Introduction	AC Input Motor & Driver	Motor Only
AR	0.36° / Geared / Geared	PK
AS	0.72° / Geared	PK
UMK	0.9°/1.8° / Geared	PK
ASX	0.36° / Geared	PK/PV
CRK	0.36°/0.72° / Geared	Geared
CMK	0.9°/1.8° / Geared	PK
RBK	1.8° / Geared	PK
PK	0.36°	PK
PK	0.72°	PK
PK	0.9°	PK
PK/PV	1.8°	PK
PK	Geared	PK
Controllers	SCX10 / EMP400 / SG8030J	Accessories

Step Angle 1.8° Motor Frame Size 35 mm (1.38 in.), 42 mm (1.65 in.) High-Torque Type

Specifications RoHS

Model	Single Shaft	CMK233PAP	CMK235PAP	CMK244PAP	CMK246PAP
	Double Shaft	CMK233PBP	CMK235PBP	CMK244PBP	CMK246PBP
	With Encoder	CMK233PAP-R	CMK235PAP-R	CMK244PAP-R	CMK246PAP-R
Maximum Holding Torque	N·m (oz·in)	0.16 (22)	0.3 (42)	0.39 (55)	0.75 (106)
Holding Torque at Motor Standstill	Power ON N·m (oz·in)	0.064 (9.0)	0.12 (17)	0.15 (21)	0.3 (42)
Rotor Inertia	J: kg·m ² (oz·in ²)	24×10 ⁻⁷ (0.131)	50×10 ⁻⁷ (0.27)	57×10 ⁻⁷ (0.31)	114×10 ⁻⁷ (0.62)
Rated Current	A/Phase	1.2			
Basic Step Angle		1.8°			
Power Source		24 VDC±10% 1.7 A			
Excitation Mode		Microstep			

- A connection cable [0.6 m (2 ft.)] is included with the connector-coupled motor and driver package.
- Enter the encoder code (**15**, **16**, **25** or **26**) in the box (■) within the model name.

Speed – Torque Characteristics

CMK233

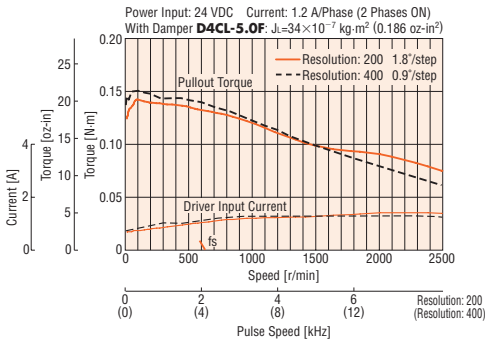

CMK235

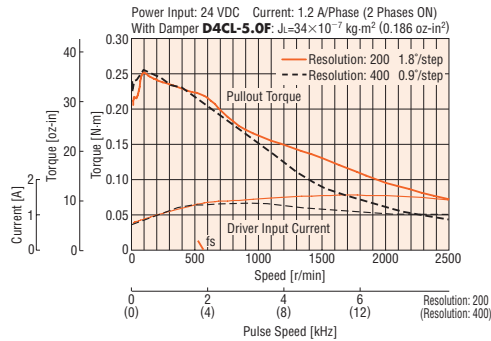

CMK244

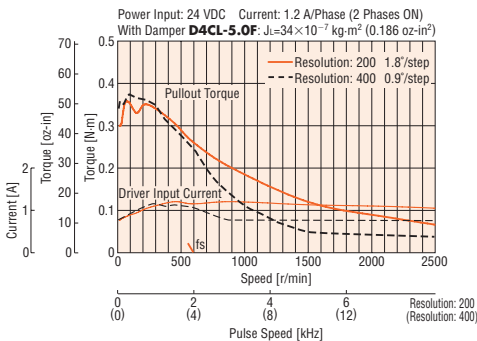

CMK246

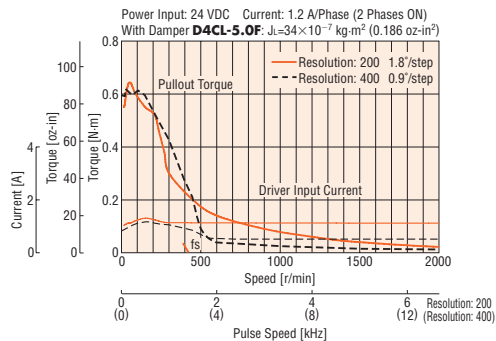

- The pulse input circuit responds to approximately 100 kHz with a pulse duty of 50%.

Note

- Pay attention to heat dissipation from the motor as there will be a considerable amount of heat under certain conditions. Be sure to keep the temperature of the motor case under 100°C (212°F).

Step Angle 1.8° Motor Frame Size 42 mm (1.65 in.), 50 mm (1.97 in.) Standard Type

Specifications RoHS

Model	Single Shaft	CMK243APA	CMK244APA	CMK245APA	CMK256AP	CMK258AP
	Double Shaft	CMK243BPA	CMK244BPA	CMK245BPA	CMK256BP	CMK258BP
	With Encoder	CMK243APA-R	CMK244APA-R	CMK245APA-R	CMK256AP-R	CMK258AP-R
Maximum Holding Torque	N·m (oz·in)	0.16 (22)	0.26 (36)	0.32 (45)	0.56 (79)	1.2 (170)
Holding Torque at Motor Standstill	Power ON N·m (oz·in)	0.064 (9.0)	0.1 (14.2)	0.12 (17.0)	0.22 (31)	0.48 (68)
Rotor Inertia	J: kg·m ² (oz·in ²)	35×10 ⁻⁷ (0.191)	54×10 ⁻⁷ (0.3)	68×10 ⁻⁷ (0.37)	230×10 ⁻⁷ (1.26)	420×10 ⁻⁷ (2.3)
Rated Current	A/Phase	0.95	1.2		2	
Basic Step Angle		1.8°				
Power Source		24 VDC±10% 1.5 A	24 VDC±10% 1.7 A		24 VDC±10% 2.9 A	
Excitation Mode		Microstep				

● Enter the encoder code (**15**, **16**, **25** or **26**) in the box (■) within the model name.

Speed – Torque Characteristics

CMK243

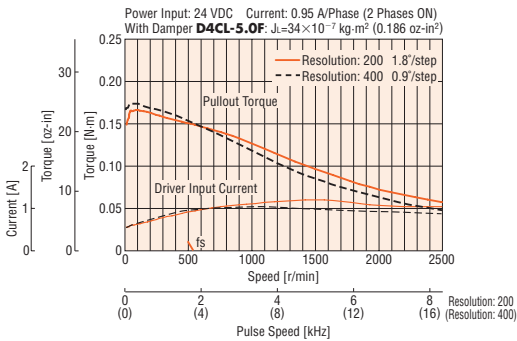

CMK244

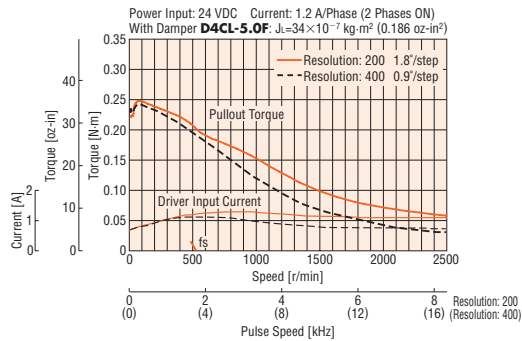

CMK245

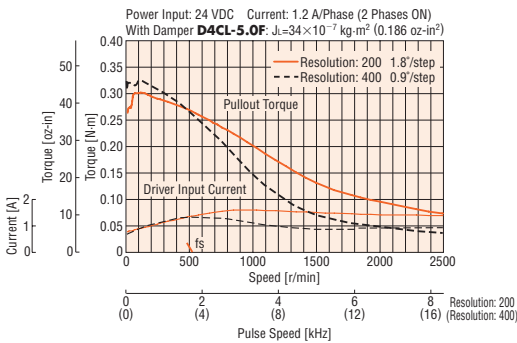

CMK256

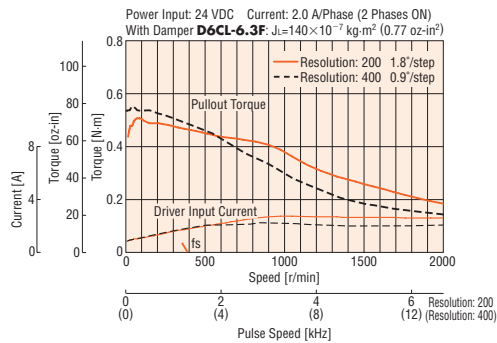

CMK258

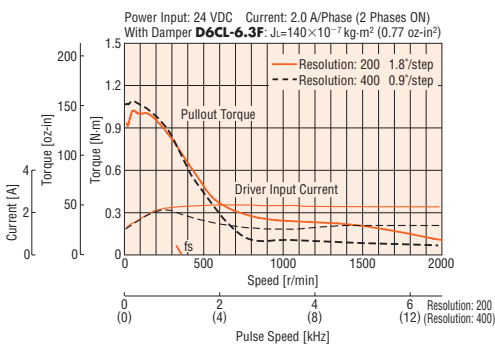

● The pulse input circuit responds to approximately 100 kHz with a pulse duty of 50%.

Note

● Pay attention to heat dissipation from the motor as there will be a considerable amount of heat under certain conditions. Be sure to keep the temperature of the motor case under 100°C (212°F).

Step Angle 1.8° Motor Frame Size 56.4 mm (2.22 in.)

Standard Type

Specifications RoHS

Model	Single Shaft	CMK264AP	CMK266AP	CMK268AP
	Double Shaft	CMK264BP	CMK266BP	CMK268BP
	With Encoder	CMK264AP-R 	CMK266AP-R 	CMK268AP-R
Maximum Holding Torque	N·m (oz-in)	0.36 (51)	0.82 (116)	1.35 (191)
Holding Torque at Motor Standstill	Power ON N·m (oz-in)	0.14 (19.8)	0.32 (45)	0.54 (76)
Rotor Inertia	J: kg·m ² (oz-in ²)	120×10 ⁻⁷ (0.66)	30×10 ⁻⁷ (1.64)	480×10 ⁻⁷ (2.6)
Rated Current	A/Phase	2		
Basic Step Angle		1.8°		
Power Source		24 VDC ±10% 2.9 A		
Excitation Mode		Microstep		

● Enter the encoder code (**15**, **16**, **25** or **26**) in the box () within the model name.

Speed – Torque Characteristics

CMK264

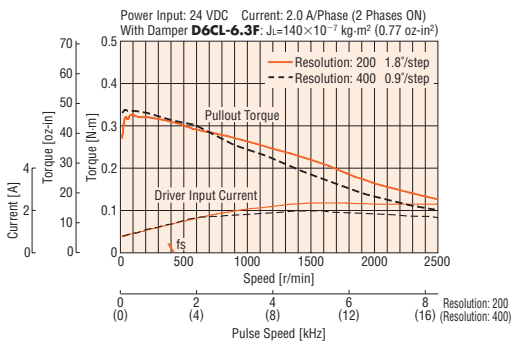

CMK266

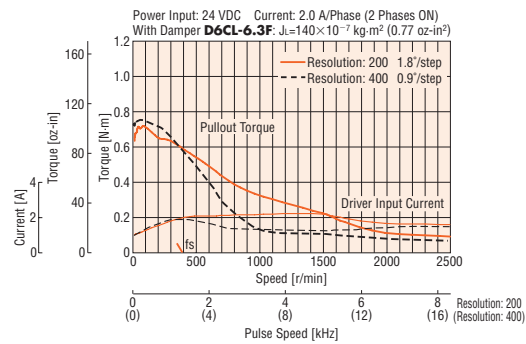

CMK268

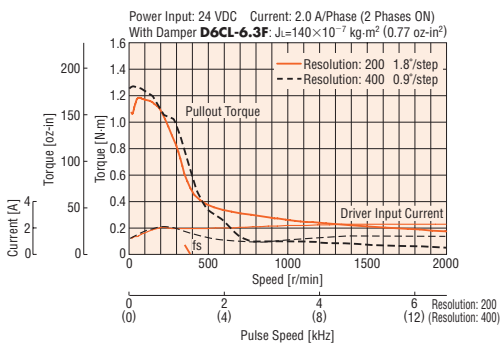

● The pulse input circuit responds to approximately 100 kHz with a pulse duty of 50%.

Note

● Pay attention to heat dissipation from the motor as there will be a considerable amount of heat under certain conditions. Be sure to keep the temperature of the motor case under 100°C (212°F).

Introduction	
AR	AC Input Motor & Driver
AR	0.36° / Geared
AS	0.72° / Geared
RK	0.9° / 1.8° / Geared
UMK	0.9° / 1.8° / Geared
AR	0.36° / Geared
ASX	0.36° / Geared
CRK	0.36° / 0.72° / Geared
CMK	0.9° / 1.8° / Geared
RBK	1.8° / Geared
PK	0.36°
PK	0.72°
PK	0.9°
PK/PV	1.8°
PK	Geared
SCX10 / EMP400 / SG8030J	Controllers
	Accessories

SH Geared Type Motor Frame Size 28 mm (1.10 in.)

Specifications RoHS

Model	Single Shaft	CMK223AP-SG7.2	CMK223AP-SG9	CMK223AP-SG10	CMK223AP-SG18	CMK223AP-SG36
	Double Shaft	CMK223BP-SG7.2	CMK223BP-SG9	CMK223BP-SG10	CMK223BP-SG18	CMK223BP-SG36
	With Encoder	CMK223PR15S7.2	CMK223PR15S9	CMK223PR15S10	CMK223PR15S18	CMK223PR15S36
Maximum Holding Torque	N·m (oz·in)	0.3 (42)			0.4 (56)	
Holding Torque at Motor Standstill	Power ON N·m (oz·in)	0.14 (19.8)	0.20 (28)	0.22 (31)	0.39 (55)	0.40 (56)
Rotor Inertia	J: kg·m ² (oz·in ²)	9×10 ⁻⁷ (0.049)				
Rated Current	A/Phase	0.95				
Basic Step Angle		0.25°	0.2°	0.18°	0.1°	0.05°
Gear Ratio		7.2	9	10	18	36
Permissible Torque	N·m (oz·in)	0.3 (42)			0.4 (56)	
Permissible Speed Range	r/min	0~250	0~200	0~180	0~100	0~50
Power Source		24 VDC ±10% 1.5 A				
Excitation Mode		Microstep				

* A connection cable [0.6 m (2 ft.)] is included with the connector-coupled motor and driver package.

Notes

- Backlash value is approximately 1 to 2°.
- Direction of rotation of the motor and that of the gear output shaft are the same for gear ratios 7.2 and 36. It is the opposite for 9, 10 and 18 gear ratios.

Speed – Torque Characteristics

CMK223 Gear Ratio 7.2

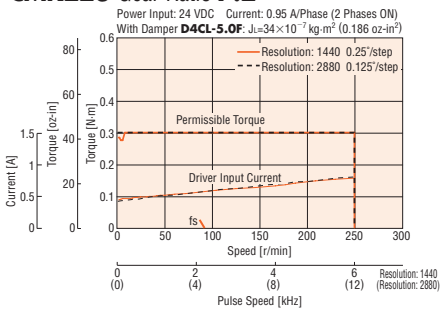

CMK223 Gear Ratio 9

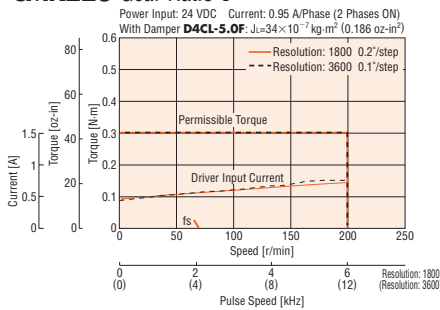

CMK223 Gear Ratio 10

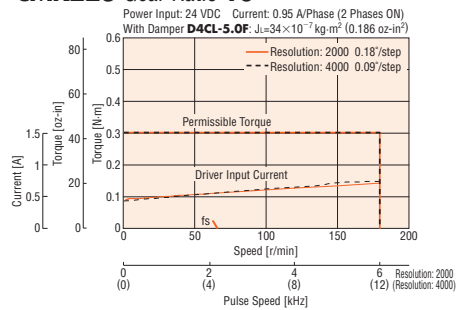

CMK223 Gear Ratio 18

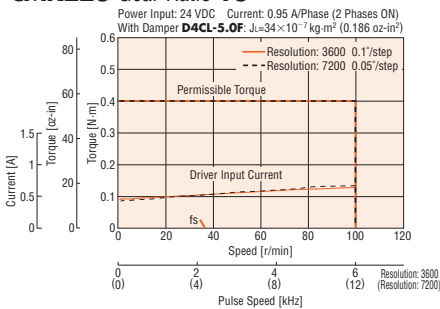

CMK223 Gear Ratio 36

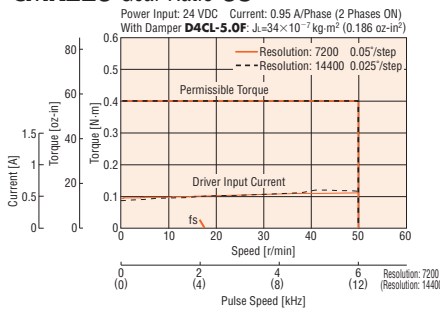

- The pulse input circuit responds to approximately 100 kHz with a pulse duty of 50%.

Note

- Pay attention to heat dissipation from the motor as there will be a considerable amount of heat under certain conditions. Be sure to keep the temperature of the motor case under 100°C (212°F).

SH Geared Type Motor Frame Size 42 mm (1.65 in.)

Specifications RoHS

Model	Single Shaft	CMK243APA-SG3.6	CMK243APA-SG7.2	CMK243APA-SG9	CMK243APA-SG10	CMK243APA-SG18	CMK243APA-SG36
	Double Shaft	CMK243BPA-SG3.6	CMK243BPA-SG7.2	CMK243BPA-SG9	CMK243BPA-SG10	CMK243BPA-SG18	CMK243BPA-SG36
	With Encoder	CMK243PAR-S3.6	CMK243PAR-S7.2	CMK243PAR-S9	CMK243PAR-S10	CMK243PAR-S18	CMK243PAR-S36
Maximum Holding Torque	N·m (lb-in)	0.2 (1.77)	0.4 (3.5)	0.5 (4.4)	0.56 (4.9)	0.8 (7)	
Holding Torque at Motor Standstill	Power ON N·m (lb-in)	0.2 (1.77)	0.4 (3.5)	0.5 (4.4)	0.56 (4.9)	0.8 (7)	
Rotor Inertia	J: kg·m ² (oz-in ²)	35 × 10 ⁻⁷ (0.191)					
Rated Current	A/Phase	0.95					
Basic Step Angle		0.5°	0.25°	0.2°	0.18°	0.1°	0.05°
Gear Ratio		3.6	7.2	9	10	18	36
Permissible Torque	N·m (lb-in)	0.2 (1.77)	0.4 (3.5)	0.5 (4.4)	0.56 (4.9)	0.8 (7)	
Permissible Speed Range	r/min	0~500	0~250	0~200	0~180	0~100	0~50
Power Source		24 VDC ± 10% 1.5 A					
Excitation Mode		Microstep					

● Enter the encoder code (**15**, **16**, **25** or **26**) in the box (■) within the model name.

Notes

- Backlash value is approximately 1 to 2°.
- Direction of rotation of the motor and that of the gear output shaft are the same for gear ratios 3.6, 7.2, 9 and 10. It is the opposite for 18 and 36 gear ratios.

Speed – Torque Characteristics

CMK243 Gear Ratio 3.6

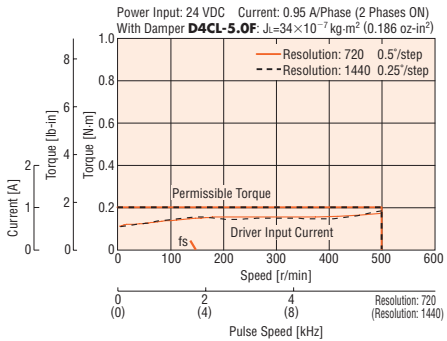

CMK243 Gear Ratio 7.2

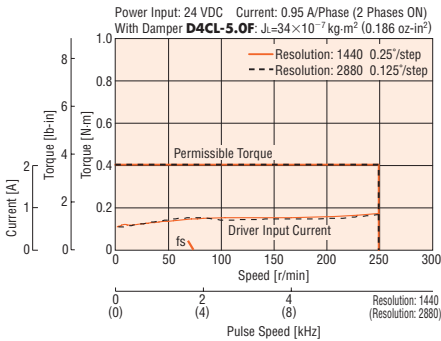

CMK243 Gear Ratio 9

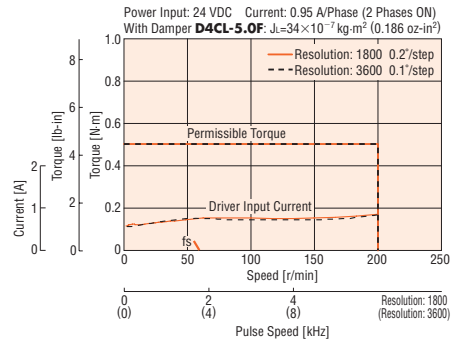

CMK243 Gear Ratio 10

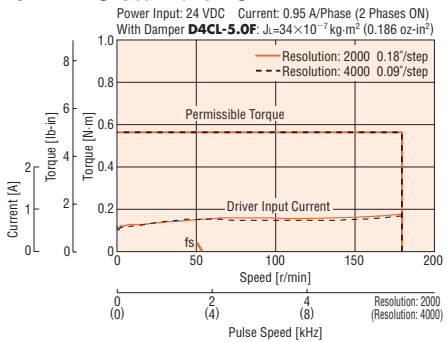

CMK243 Gear Ratio 18

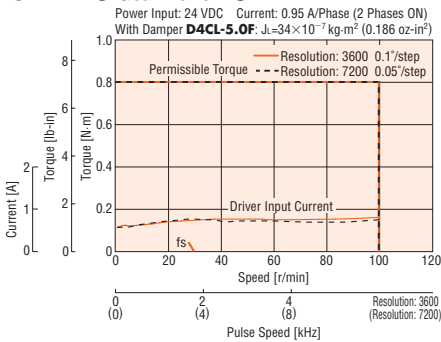

CMK243 Gear Ratio 36

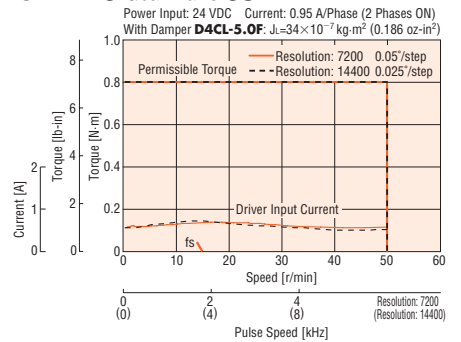

● The pulse input circuit responds to approximately 100 kHz with a pulse duty of 50%.

Note

- Pay attention to heat dissipation from the motor as there will be a considerable amount of heat under certain conditions. Be sure to keep the temperature of the motor case under 100°C (212°F).

Introduction
AR
DC Input Motor & Driver
0.36° / Geared
0.72° / Geared
AS
RK
UMK
0.9°/1.8° / Geared
0.36° / Geared
ASX
DC Input Motor & Driver
0.36°/0.72° / Geared
CRK
CMK
1.8° / Geared
RBK
0.36° / Geared
PK
PK
PK
Motor Only
PK
1.8° / Geared
PK
PK
Controllers
SCX10
EMPA400
/SG8030J
Accessories

SH Geared Type Motor Frame Size 60 mm (2.36 in.)

Specifications RoHS

Model	Single Shaft	CMK264APA-SG3.6	CMK264APA-SG7.2	CMK264APA-SG9	CMK264APA-SG10	CMK264APA-SG18	CMK264APA-SG36
	Double Shaft	CMK264BPA-SG3.6	CMK264BPA-SG7.2	CMK264BPA-SG9	CMK264BPA-SG10	CMK264BPA-SG18	CMK264BPA-SG36
	With Encoder	CMK264PAR-S3.6	CMK264PAR-S7.2	CMK264PAR-S9	CMK264PAR-S10	CMK264PAR-S18	CMK264PAR-S36
Maximum Holding Torque	N·m (lb-in)	1 (8.8)	2 (17.7)	2.5 (22)	2.7 (23)	3 (26)	4 (35)
Holding Torque at Motor Standstill	Power ON N·m (lb-in)	0.56 (4.9)	1.1 (9.7)	1.4 (12.3)	1.5 (13.2)	3 (26)	4 (35)
Rotor Inertia	J: kg·m ² (oz-in ²)	120 × 10 ⁻⁷ (0.66)					
Rated Current	A/Phase	2					
Basic Step Angle		0.5°	0.25°	0.2°	0.18°	0.1°	0.05°
Gear Ratio		3.6	7.2	9	10	18	36
Permissible Torque	N·m (lb-in)	1 (8.8)	2 (17.7)	2.5 (22)	2.7 (23)	3 (26)	4 (35)
Permissible Speed Range	r/min	0~500	0~250	0~200	0~180	0~100	0~50
Power Source		24 VDC ± 10% 2.9 A					
Excitation Mode		Microstep					

● Enter the encoder code (**15**, **16**, **25** or **26**) in the box (■) within the model name.

Notes

- Backlash value is approximately 1 to 2°.
- Direction of rotation of the motor and that of the gear output shaft are the same for gear ratios 3.6, 7.2, 9 and 10. It is the opposite for 18 and 36 gear ratios.

Speed – Torque Characteristics

CMK264 Gear Ratio 3.6

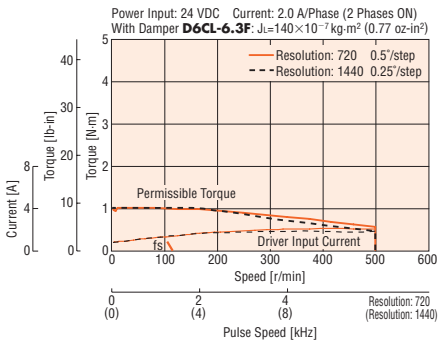

CMK264 Gear Ratio 7.2

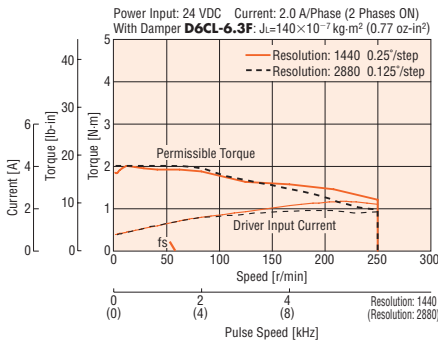

CMK264 Gear Ratio 9

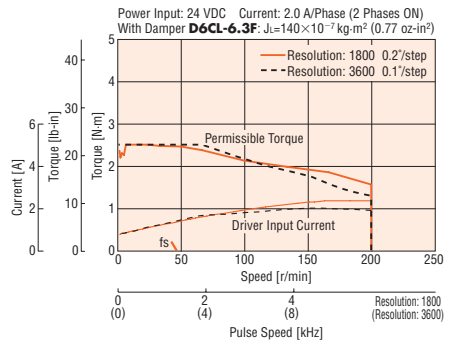

CMK264 Gear Ratio 10

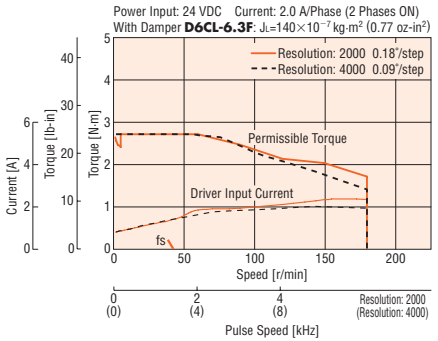

CMK264 Gear Ratio 18

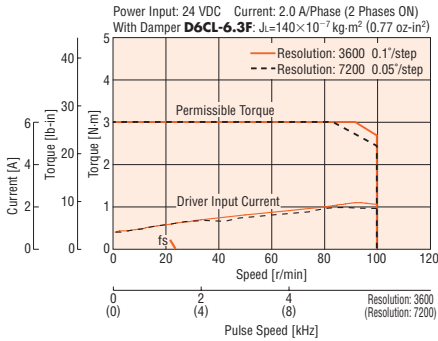

CMK264 Gear Ratio 36

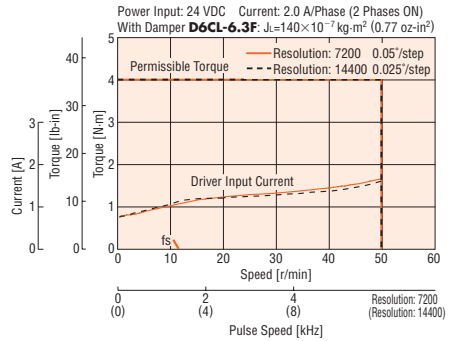

● The pulse input circuit responds to approximately 100 kHz with a pulse duty of 50%.

Note

- Pay attention to heat dissipation from the motor as there will be a considerable amount of heat under certain conditions. Be sure to keep the temperature of the motor case under 100°C (212°F).

Driver Specifications

Input Signals	Input Mode	Photocoupler input Pulse (CW pulse) signal, Rotation direction (CCW pulse) signal: Input resistance 200 Ω, Input current 5~20 mA Photocoupler ON: +3~5.25 V, Photocoupler OFF: 0~+1 V (Voltage between terminals) All windings off signal, Step angle select signal, Automatic current cutback release signal Input resistance 3.3 kΩ, Input current 1 mA (5 VDC)/8 mA (24 VDC) Photocoupler ON: +4.5~26.4 V, Photocoupler OFF: 0~+1 V (Voltage between terminals)
	Pulse Signal (CW Pulse Signal)	Operation command pulse signal (CW direction operation command pulse signal when in 2-pulse input mode), Negative logic pulse input Pulse width: 5 μs minimum, Pulse rise/fall: 2 μs maximum, Pulse duty: 50% and below Motor moves one step when the pulse input is switched from ON to OFF Maximum input pulse frequency: 100 kHz (When the pulse duty is 50%)
	Rotation Direction Signal (CCW Pulse Signal)	Rotation direction signal, Photocoupler ON: CW, Photocoupler OFF: CCW (CCW direction operation command pulse signal when in 2-pulse input mode.) Negative logic pulse input Pulse width: 5 μs minimum, Pulse rise/fall: 2 μs maximum, Pulse duty: 50% and below Motor moves one step when the pulse input is switched from photocoupler ON to OFF Maximum input pulse frequency: 100 kHz (When the pulse duty is 50%)
	All Windings Off Signal	When in the "photocoupler ON" state, the output current to the motor is cut off and the motor shaft can be rotated manually. When in the "photocoupler OFF" state, the current is supplied to the motor.
	Step Angle Select Signal	When in the "photocoupler ON" state, the motor operates at the basic step angle regardless of the settings of the step angle setting switches. When in the "photocoupler OFF" state, the motor operates at the step angle set by the step angle setting switches.
	Automatic Current Cutback Release Signal	When in the "photocoupler ON" state, the automatic current cutback function will not be activated even after the motor stops. When in the "photocoupler OFF" state, the automatic current cutback function will be activated after the motor stops (after approx. 100 msec).
	Output Mode	Photocoupler, Open-collector output External use condition: 24 VDC maximum, 10 mA maximum
Output Signal	Excitation Timing Signal	The signal is output every time the excitation sequence returns to the initial stage "0." (Photocoupler: ON) <ul style="list-style-type: none"> •Step Angle 1.8° High-torque type, Step Angle 1.8° standard type 1.8°/step [Microsteps/step: 1 (Resolution: 200)]: Signal is output every 4 pulses 0.45°/step [Microsteps/step: 4 (Resolution: 800)]: Signal is output every 16 pulses •Step Angle 0.9° Standard Type 0.9°/step [Microsteps/step: 1 (Resolution: 400)]: Signal is output every 4 pulses 0.225°/step [Microsteps/step: 4 (Resolution: 1600)]: Signal is output every 16 pulses •SH geared type (gear ratio 18) 0.1°/step [Microsteps/step: 1 (Resolution: 3600)]: Signal is output every 4 pulses 0.025°/step [Microsteps/step: 4 (Resolution: 14400)]: Signal is output every 16 pulses
		Functions
Cooling Method		Natural ventilation

General Specifications

Item	Motor	Driver
Thermal Class	130 (B)	—
Insulation Resistance	100 MΩ or more when 500 VDC megger is applied between the windings and the case under normal ambient temperature and humidity.	—
Dielectric Strength	Sufficient to withstand 1.0 kVAC at 50 Hz or 60 Hz applied between the windings and the case for 1 minute under normal ambient temperature and humidity. [0.5 kVAC for models with frame size 42 mm (1.65 in.) or smaller]	—
Operating Environment	Ambient Temperature	-10~+50°C (+14~+122°F) (non-freezing)
	Ambient Humidity	85% or less (non-condensing)
	Atmosphere	No corrosive gases, dust, water or oil
Temperature Rise	Temperature rise of windings is 80°C (144°F) or less measured by the resistance change method. (at rated voltage, at standstill, two phases energized)	—
Stop Position Accuracy*1	±3 arc minutes (±0.05°)	—
Shaft Runout	0.05 mm (0.002 in.) T.I.R.*4	—
Radial Play*2	0.025 mm (0.001 in.) maximum of 5 N (1.12 lb.)	—
Axial Play*3	0.075 mm (0.003 in.) maximum of 10 N (2.2 lb.)	—
Concentricity	0.075 mm (0.003 in.) T.I.R.*4	—
Perpendicularity	0.075 mm (0.003 in.) T.I.R.*4	—

*1 This value is for full step under no load. (The value changes with the size of the load.)

*2 Radial Play: Displacement in shaft position in the radial direction when a 5 N (1.12 lb.) load is applied in the vertical direction to the tip of the motor's shaft.

*3 Axial Play: Displacement in shaft position in the axial direction when a 10 N (2.2 lb.) load is applied to the motor's shaft in the axial direction.

*4 T.I.R. (Total Indicator Reading): The total dial gauge reading when the measurement section is rotated one revolution centered on the reference axis center.

Note

● Do not measure insulation resistance or perform the dielectric strength test while the motor and driver are connected.

Permissible Overhung Load and Permissible Thrust Load

→ Page A-14

Encoder Specifications

→ Page A-17

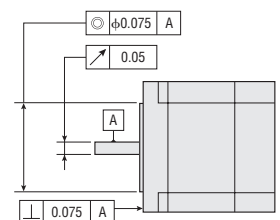

Dimensions Unit = mm (in.)

The dimensions of a motor with an encoder can be found on page A-19 or at www.orientalmotor.com.

● Motor

◇ Step Angle 1.8° High-Torque Type

Motor Frame Size 28 mm (1.10 in.)

Model	Motor Model	L1	L2	Mass kg (lb.)	DXF
CMK223PAP	PK223PA	32 (1.26)	—	0.11 (0.24)	B326
CMK223PBP	PK223PB		42 (1.65)		
CMK224PAP	PK224PA	40 (1.57)	—	0.14 (0.31)	B327
CMK224PBP	PK224PB		50 (1.97)		
CMK225PAP	PK225PA	51.5 (2.03)	—	0.2 (0.44)	B328
CMK225PBP	PK225PB		61.5 (2.42)		

A connection cable of 0.6 m (2 ft.) is included with the package. UL Style 3265, AWG24

If you are purchasing only a motor for maintenance purposes, etc., the connection cable and connector will not be supplied. They must be purchased separately.

→ Page A-406

● Applicable Connector

Connector housing: 51065-0600 (MOLEX)

Contact: 50212-8100 (MOLEX)

Crimp tool: 57176-5000 (MOLEX)

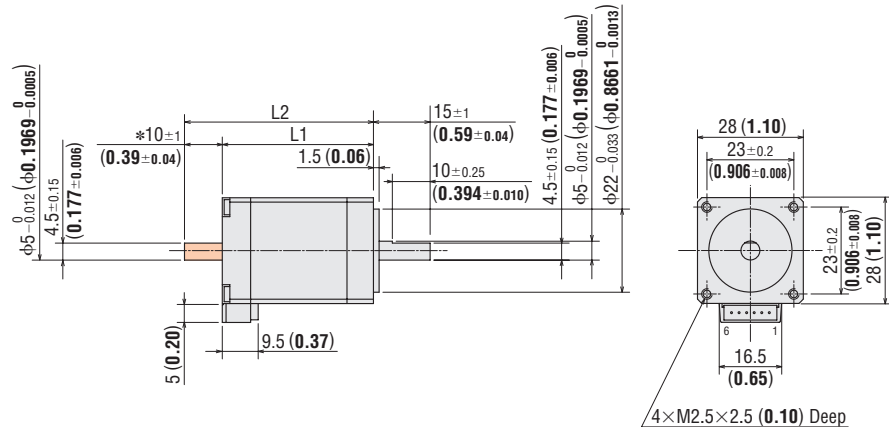

*The length of machining on the double shaft model is 10±0.25 (0.394±0.010).

Motor Frame Size 35 mm (1.38 in.)

Model	Motor Model	L1	L2	Mass kg (lb.)	DXF
CMK233PAP	PK233PA	37 (1.46)	—	0.18 (0.4)	B329
CMK233PBP	PK233PB		52 (2.05)		
CMK235PAP	PK235PA	52 (2.05)	—	0.285 (0.63)	B330
CMK235PBP	PK235PB		67 (2.64)		

A connection cable of 0.6 m (2 ft.) is included with the package. UL Style 3265, AWG24

If you are purchasing only a motor for maintenance purposes, etc., the connection cable and connector will not be supplied. They must be purchased separately.

→ Page A-406

● Applicable Connector

Connector housing: 51103-0600 (MOLEX)

Contact: 50351-8100 (MOLEX)

Crimp tool: 57295-5000 (MOLEX)

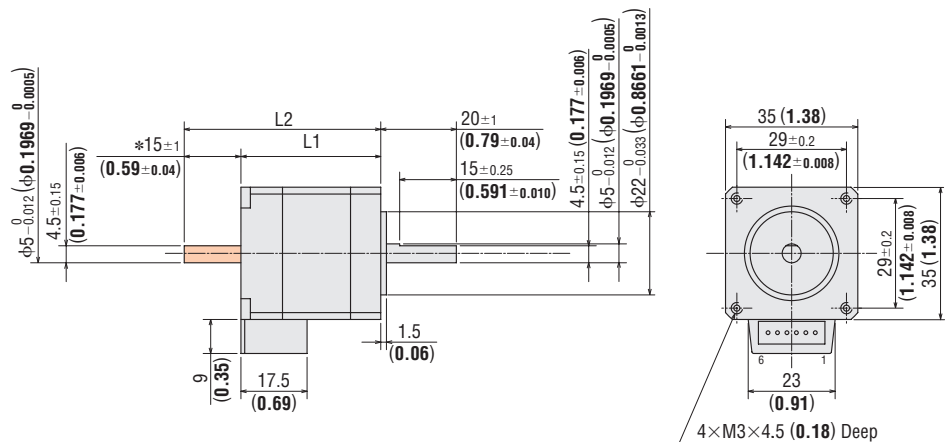

*The length of machining on the double shaft model is 15±0.25 (0.591±0.010).

● These dimensions are for the double shaft models. For the single shaft models, ignore the orange () areas.

● The dimensions of a motor with an encoder can be found on page A-19 or at www.orientalmotor.com.

Motor Frame Size 42 mm (1.65 in.)

Model	Motor Model	L1	L2	Mass kg (lb.)	DXF
CMK244PAP	PK244PA	39 (1.54)	—	0.3 (0.66)	B331
CMK244PBP	PK244PB		54 (2.13)		
CMK246PAP	PK246PA	59 (2.32)	—	0.5 (1.1)	B332
CMK246PBP	PK246PB		74 (2.91)		

A connection cable of 0.6 m (2 ft.) is included with the package. UL Style 3265, AWG24

If you are purchasing only a motor for maintenance purposes, etc., the connection cable and connector will not be supplied. They must be purchased separately.

→ Page A-406

● Applicable Connector

Connector housing: 51103-0600 (MOLEX)

Contact: 50351-8100 (MOLEX)

Crimp tool: 57295-5000 (MOLEX)

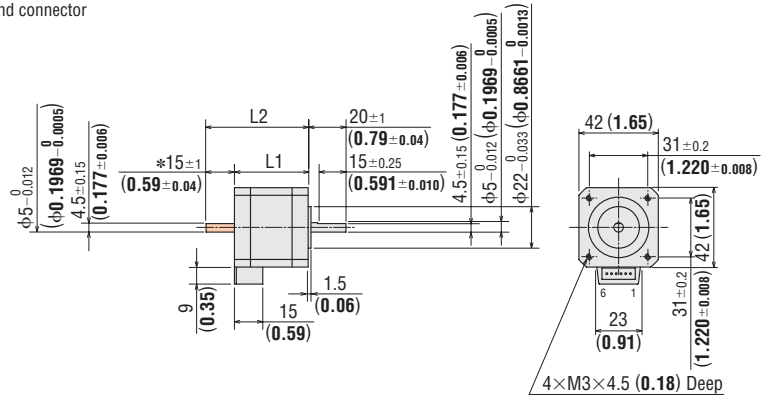

*The length of machining on the double shaft model is $15_{\pm 0.25}$ ($0.591_{\pm 0.010}$).

Motor Frame Size 56.4 mm (2.22 in.)

Model	Motor Model	L1	L2	Mass kg (lb.)	DXF
CMK264PAPA	PK264PAA	39 (1.54)	—	0.46 (1.01)	B443U
CMK264PBP	PK264PBA		55 (2.17)		
CMK266PAPA	PK266PAA	54 (2.13)	—	0.73 (1.61)	B444U
CMK266PBP	PK266PBA		70 (2.76)		
CMK268PAPA	PK268PAA	76 (2.99)	—	1.1 (2.42)	B445U
CMK268PBP	PK268PBA		92 (3.62)		

A connection cable of 0.6 m (2 ft.) is included with the package. UL Style 3265, AWG24

If you are purchasing only a motor for maintenance purposes, etc., the connection cable and connector will not be supplied. They must be purchased separately.

→ Page A-406

● Applicable Connector for Motor:

Connector housing: 51067-0600 (MOLEX)

Contact: 50217-9101 (MOLEX)

Crimp tool: 57189-5000 (MOLEX) or 57190-5000 (MOLEX)

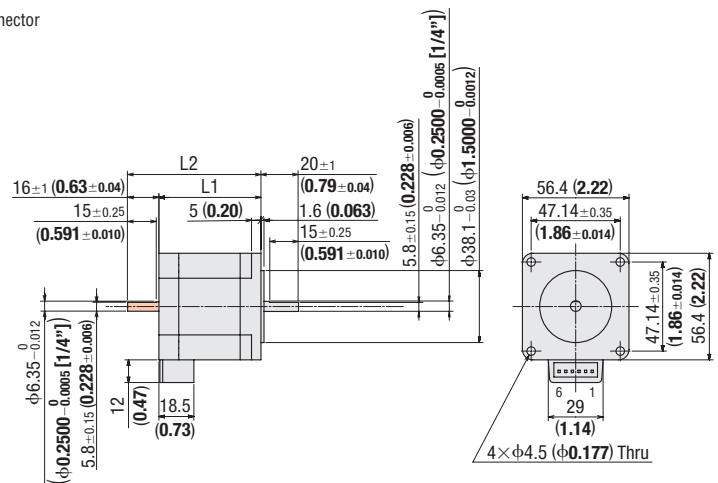

● These dimensions are for the double shaft models. For the single shaft models, ignore the orange () areas.

● The dimensions of a motor with an encoder can be found on page A-19 or at www.orientalmotor.com.

◇ Step Angle 0.9° Standard Type, Step Angle 1.8° Standard Type

Motor Frame Size 42 mm (1.65 in.)

Model	Motor Model	L1	L2	Mass kg (lb.)	DXF
CMK243APA	PK243-01AA	33 (1.3)	—	0.21 (0.46)	B081U
CMK243MAPA	PK243MAA		—	0.24 (0.53)	
CMK243BPA	PK243-01BA		48 (1.89)	0.21 (0.46)	
CMK243MBPA	PK243MBA		—	0.24 (0.53)	
CMK244APA	PK244-01AA	39 (1.54)	—	0.27 (0.59)	B082U
CMK244MAPA	PK244MAA		—	0.3 (0.66)	
CMK244BPA	PK244-01BA		54 (2.13)	0.27 (0.59)	
CMK244MBPA	PK244MBA		—	0.3 (0.66)	
CMK245APA	PK245-01AA	47 (1.85)	—	0.35 (0.77)	B083U
CMK245MAPA	PK245MAA		—	0.37 (0.81)	
CMK245BPA	PK245-01BA		62 (2.44)	0.35 (0.77)	
CMK245MBPA	PK245MBA		—	0.37 (0.81)	

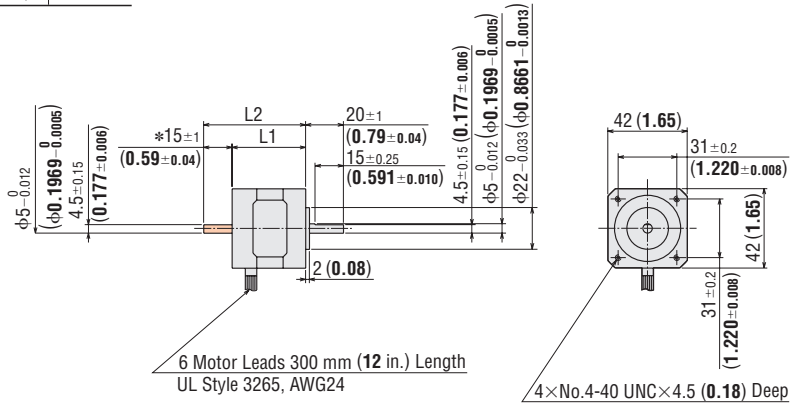

*The length of machining on the double shaft model is $15_{\pm 0.25}$ ($0.591_{\pm 0.010}$).

◇ Step Angle 1.8° Standard Type

Motor Frame Size 50 mm (1.97 in.)

Model	Motor Model	L1	L2	Mass kg (lb.)	DXF
CMK256AP	PK256-02A	51.5 (2.03)	—	0.53 (1.17)	B333
CMK256BP	PK256-02B		67.5 (2.66)		
CMK258AP	PK258-02A	81 (3.19)	—	0.89 (1.96)	B334
CMK258BP	PK258-02B		97 (3.82)		

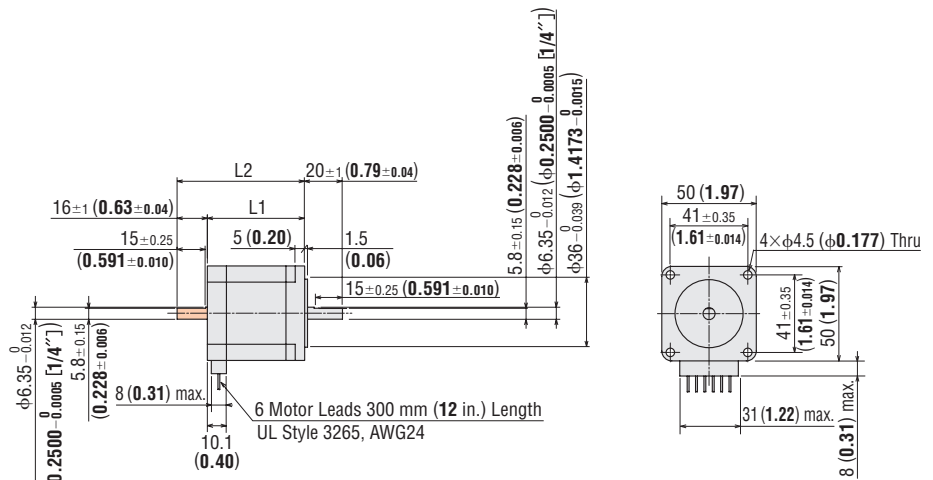

● These dimensions are for the double shaft models. For the single shaft models, ignore the orange () areas.
● The dimensions of a motor with an encoder can be found on page A-19 or at www.orientalmotor.com.

Motor Frame Size 42 mm (1.65 in.)

Model	Motor Model	Gear Ratio	Mass kg (lb.)	DXF
CMK243APA-SG <input type="checkbox"/>	PK243A1A-SG <input type="checkbox"/>	3.6, 7.2, 9, 10, 18, 36	0.35 (0.77)	B091U
CMK243BPA-SG <input type="checkbox"/>	PK243B1A-SG <input type="checkbox"/>			

● Enter the gear ratio in the box () within the model name.

● Screws (Included)
 No.4-40 UNC Length 10 mm (0.39 in.) ... 4 pieces

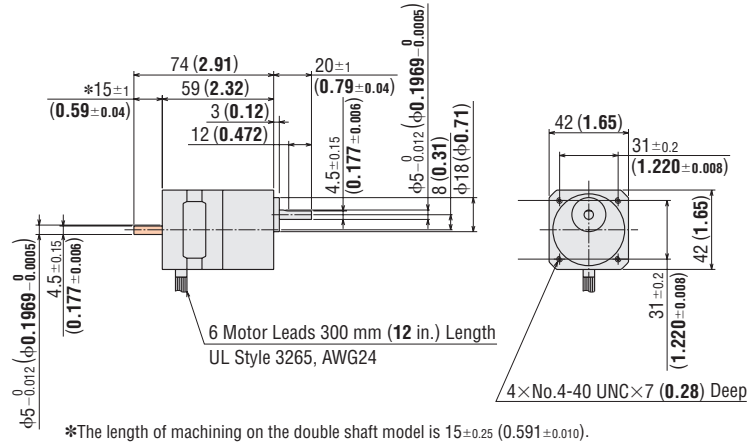

*The length of machining on the double shaft model is 15 ± 0.25 (0.591 \pm 0.010).

Motor Frame Size 60 mm (2.36 in.)

Model	Motor Model	Gear Ratio	Mass kg (lb.)	DXF
CMK264APA-SG <input type="checkbox"/>	PK264A2A-SG <input type="checkbox"/>	3.6, 7.2, 9, 10, 18, 36	0.75 (1.65)	B092U
CMK264BPA-SG <input type="checkbox"/>	PK264B2A-SG <input type="checkbox"/>			

● Enter the gear ratio in the box () within the model name.

● Screws (Included)
 No.8-32 UNC Length 15.8 mm (0.62 in.) ... 4 pieces

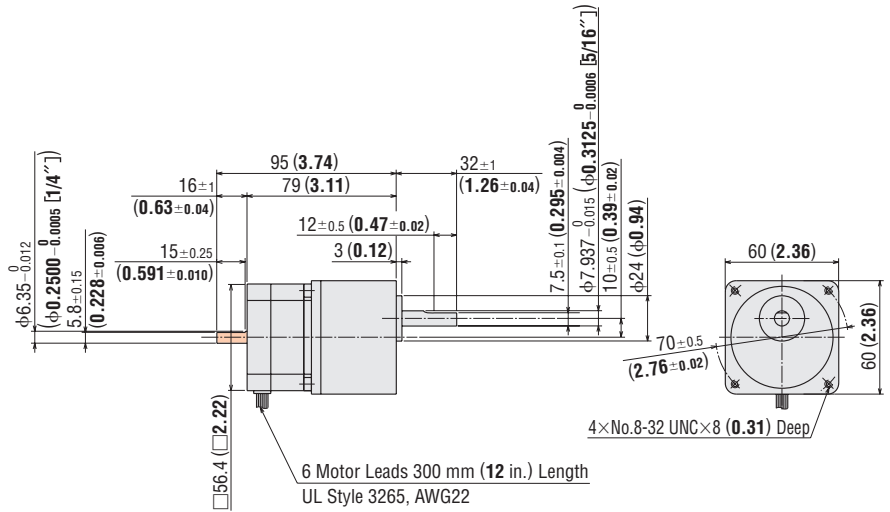

● These dimensions are for the double shaft models. For the single shaft models, ignore the orange () areas.
 ● The dimensions of a motor with an encoder can be found on page A-19 or at www.orientalmotor.com.

● Driver

CMD2109P, CMD2112P, CMD2120P

Mass: 0.05 kg (0.11 lb.)

DXF B441

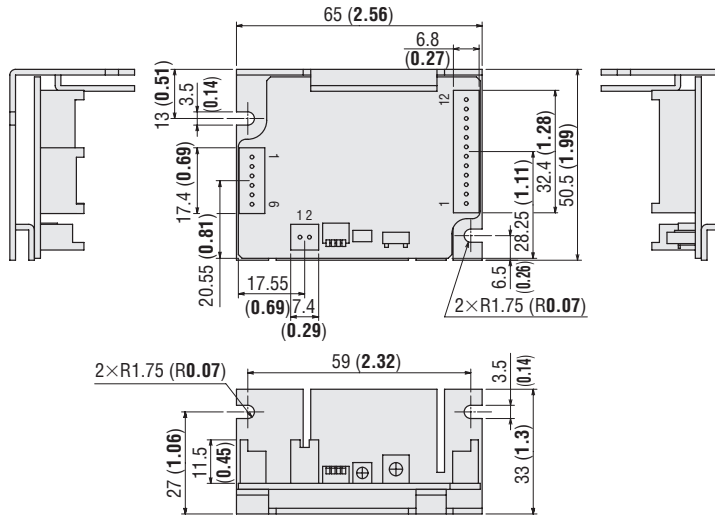

- Connector Housing (Included)
 - 51103-0200 (MOLEX)
 - 51103-1200 (MOLEX)
 - 51103-0600 (MOLEX)
- Contact (Included)
 - 50351-8100 (MOLEX)

Note

- Use the included connector for power supply, signal and motor. When assembling the connectors, use the hand-operated crimp tool [57295-5000 (MOLEX)]. The crimp tool is not included with the package. It must be purchased separately.
- Connection cable set crimped with connector is available (sold separately). → Page A-406

Introduction	AC Input Motor & Driver	DC Input Motor & Driver	Motor Only	Controllers	Accessories								
AR	AS	AR	ASX	CRK	CMK	RBK	PK	PK	PK	PK/PV	PK	SCX10 EMP400 /SG8030J	
	0.36° /Geared	0.36° /Geared	0.36° /Geared	0.36° /Geared	0.36° /Geared	0.36° /Geared	0.36°	0.72°	0.9°	1.8°	Geared		
	RK	UMK											
	0.72° /Geared	0.9°/1.8° /Geared	0.9°/1.8° /Geared	1.8° /Geared									

Connection and Operation

Names and Functions of Driver Parts

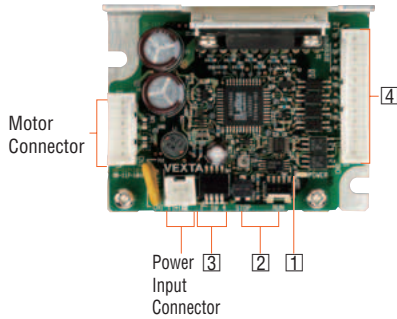

1 Power Input Display

Color	Function	When Activated
Green	Power supply indication	Lights when power is on.

2 Current Adjustment Switches

Indication	Switch Name	Function
RUN	Motor run current switch	For adjusting the motor running current.
STOP	Motor stop current potentiometer	For adjusting the motor current at standstill.

3 Function Select Switches

Indication	Switch Name	Function
1	Pulse input mode switch	Switches between 1-pulse input and 2-pulse input.
2, 3, 4	Step angle setting switch	These switches can be set to the desired resolution from the five resolution levels.

Step Angle Setting Switches

SW-2	SW-3	SW-4	Microsteps/Step	Resolution	Step Angle
OFF	OFF	OFF	1	200	1.8°
OFF	OFF	ON	2	400	0.9°
OFF	ON	OFF	4	800	0.45°
OFF	ON	ON	8	1600	0.225°
ON	OFF	OFF	16	3200	0.1125°

Notes

- Use of any setting other than the combinations listed in the table will automatically set the microstep to "1" and the motor will operate at the basic step angle.
- The step angle is calculated by dividing the basic step angle by the number of microsteps. The above figures are based on a basic step angle of 1.8°.
- With the step angle 0.9° standard type, the resolution is 400 (microsteps/step 1).
- If you are using a geared type, the step angle divided by the gear ratio becomes the actual step angle.
- The step angle set with the step angle setting switches will become effective when the "Step Angle Select" (CS) signal input is OFF.
- Do not change the "Step Angle Select" (CS) signal input or step angle setting switches while the motor is operating. It may cause the motor to misstep and stop. Change the step angle setting switches when the "Step Angle Select" (CS) signal input is OFF and the "Excitation Timing" (TIM) signal output is ON.

4 Input/Output Signals

Indication	Input/Output	Pin No.	Signal Name	Function
CN2	Input	1	Pulse signal (CW pulse signal)	Operation command pulse signal (The motor will rotate in the CW direction when in 2-pulse input mode.)
		2		
		3	Rotation direction signal (CCW pulse signal)	Rotation direction signal Photocoupler ON: CW, Photocoupler OFF: CCW (The motor will rotate in the CCW direction when in 2-pulse input mode.)
		4		
		5	All windings off signal	Cuts the output current to the motor and allows the motor shafts to be rotated manually.
		6		
		7	Step angle select signal	The motor will operate at the basic step angle regardless of the settings of the step angle setting switches.
		8		
		9	Automatic current cutback release signal	This signal is used to disable the automatic current cutback function.
		10		
Output		11	Excitation timing signal	Outputs signals when the excitation sequence is at STEP "0."
		12		

List of Motor and Driver Combinations

Type	Model	Motor Model	Driver Model
Step Angle 0.9° Standard Type	CMK243M □PA	PK243M□A	CMD2109P
	CMK244M □PA	PK244M□A	
	CMK245M □PA	PK245M□A	CMD2112P
Step Angle 0.9° Standard Type	CMK264M □P	PK264M□	CMD2120P
	CMK266M □P	PK266M□	
	CMK268M □P	PK268M□	
Step Angle 0.9° Standard Type with Encoder	CMK243MAPA-R15	PK243MAAR15	CMD2109P
	CMK243MAPA-R16	PK243MAAR16	
	CMK243MAPA-R25	PK243MAAR25	
	CMK243MAPA-R26	PK243MAAR26	
	CMK244MAPA-R15	PK244MAAR15	CMD2112P
	CMK244MAPA-R16	PK244MAAR16	
	CMK244MAPA-R25	PK244MAAR25	
	CMK244MAPA-R26	PK244MAAR26	
	CMK245MAPA-R15	PK245MAAR15	CMD2112P
	CMK245MAPA-R16	PK245MAAR16	
	CMK245MAPA-R25	PK245MAAR25	
	CMK245MAPA-R26	PK245MAAR26	
CMK264MAP-R15	PK264MAR15	CMD2120P	
CMK264MAP-R16	PK264MAR16		
CMK264MAP-R25	PK264MAR25		
CMK264MAP-R26	PK264MAR26		
CMK266MAP-R15	PK266MAR15	CMD2120P	
CMK266MAP-R16	PK266MAR16		
CMK266MAP-R25	PK266MAR25		
CMK266MAP-R26	PK266MAR26		
CMK268MAP-R15	PK268MAR15	CMD2120P	
CMK268MAP-R16	PK268MAR16		
CMK268MAP-R25	PK268MAR25		
CMK268MAP-R26	PK268MAR26		
Step Angle 1.8° High-Torque Type	CMK223P □P	PK223P□*	CMD2109P
	CMK224P □P	PK224P□*	
	CMK225P □P	PK225P□*	
	CMK233P □P	PK233P□*	CMD2112P
	CMK235P □P	PK235P□*	
	CMK244P □P	PK244P□*	
CMK246P □P	PK246P□*	CMD2120P	
CMK264P □PA	PK264P□A*		
CMK268P □PA	PK268P□A*		
Step Angle 1.8° High-Torque Type with Encoder	CMK223PAP-R15	PK223PAR15	CMD2109P
	CMK224PAP-R15	PK224PAR15	
	CMK225PAP-R15	PK225PAR15	
	CMK233PAP-R15	PK233PAR15	CMD2112P
	CMK233PAP-R16	PK233PAR16	
	CMK233PAP-R25	PK233PAR25	
	CMK233PAP-R26	PK233PAR26	
	CMK235PAP-R15	PK235PAR15	
	CMK235PAP-R16	PK235PAR16	
	CMK235PAP-R25	PK235PAR25	CMD2120P
	CMK235PAP-R26	PK235PAR26	
	CMK244PAP-R15	PK244PAR15	
	CMK244PAP-R16	PK244PAR16	
	CMK244PAP-R25	PK244PAR25	
	CMK244PAP-R26	PK244PAR26	
	CMK246PAP-R15	PK246PAR15	CMD2120P
	CMK246PAP-R16	PK246PAR16	
	CMK246PAP-R25	PK246PAR25	
CMK246PAP-R26	PK246PAR26		
CMK264PAPA-R15	PK264PAAR15		
CMK264PAPA-R16	PK264PAAR16		
CMK264PAPA-R25	PK264PAAR25	CMD2120P	
CMK264PAPA-R26	PK264PAAR26		
CMK266PAPA-R15	PK266PAAR15		
CMK266PAPA-R16	PK266PAAR16		
CMK266PAPA-R25	PK266PAAR25		
CMK266PAPA-R26	PK266PAAR26		
CMK268PAPA-R15	PK268PAAR15	CMD2120P	
CMK268PAPA-R16	PK268PAAR16		
CMK268PAPA-R25	PK268PAAR25		
CMK268PAPA-R26	PK268PAAR26		

● Enter **A** (single shaft) or **B** (double shaft) in the box (□) within the model name.
 * If you are purchasing only a motor for maintenance purpose, etc., a connection cable will not be supplied. They must be purchased separately.
 They are available as accessories.
 Connection Cable → Page A-406

Type	Model	Motor Model	Driver Model	
Step Angle 1.8° Standard Type	CMK243 □PA	PK243-01□A	CMD2109P	
	CMK244 □PA	PK244-01□A		
	CMK245 □PA	PK245-01□A	CMD2112P	
Step Angle 1.8° Standard Type	CMK256 □P	PK256-02□	CMD2120P	
	CMK258 □P	PK258-02□		
	CMK264 □P	PK264-02□		
Step Angle 1.8° Standard Type	CMK266 □P	PK266-02□	CMD2109P	
	CMK268 □P	PK268-02□		
	CMK243APA-R15	PK243-01AAR15		CMD2109P
CMK243APA-R16	PK243-01AAR16			
CMK243APA-R25	PK243-01AAR25			
CMK243APA-R26	PK243-01AAR26			
Step Angle 1.8° Standard Type	CMK244APA-R15	PK244-01AAR15	CMD2112P	
	CMK244APA-R16	PK244-01AAR16		
	CMK244APA-R25	PK244-01AAR25		
Step Angle 1.8° Standard Type	CMK245APA-R15	PK245-01AAR15	CMD2112P	
	CMK245APA-R16	PK245-01AAR16		
	CMK245APA-R25	PK245-01AAR25		
Step Angle 1.8° Standard Type	CMK245APA-R26	PK245-01AAR26	CMD2112P	
	CMK256AP-R15	PK256-02AR15		CMD2120P
	CMK256AP-R16	PK256-02AR16		
CMK256AP-R25	PK256-02AR25	CMD2120P		
CMK256AP-R26	PK256-02AR26			
Step Angle 1.8° Standard Type with Encoder	CMK258AP-R15		PK258-02AR15	CMD2120P
	CMK258AP-R16	PK258-02AR16		
	CMK258AP-R25	PK258-02AR25		
Step Angle 1.8° Standard Type with Encoder	CMK258AP-R26	PK258-02AR26	CMD2120P	
	CMK264AP-R15	PK264-02AR15		
	CMK264AP-R16	PK264-02AR16		
Step Angle 1.8° Standard Type with Encoder	CMK264AP-R25	PK264-02AR25	CMD2120P	
	CMK264AP-R26	PK264-02AR26		
	CMK266AP-R15	PK266-02AR15		CMD2120P
CMK266AP-R16	PK266-02AR16			
CMK266AP-R25	PK266-02AR25	CMD2120P		
CMK266AP-R26	PK266-02AR26			
Step Angle 1.8° Standard Type with Encoder	CMK268AP-R15		PK268-02AR15	CMD2120P
	CMK268AP-R16	PK268-02AR16		
	CMK268AP-R25	PK268-02AR25		
Step Angle 1.8° Standard Type with Encoder	CMK268AP-R26	PK268-02AR26	CMD2120P	

Type	Model	Motor Model	Driver Model		
SH Geared Type	CMK223□P-SG7.2 CMK223□P-SG9 CMK223□P-SG10 CMK223□P-SG18 CMK223□P-SG36	PK223P□-SG7.2* PK223P□-SG9* PK223P□-SG10* PK223P□-SG18* PK223P□-SG36*	CMD2109P		
	CMK243□PA-SG3.6 CMK243□PA-SG7.2 CMK243□PA-SG9 CMK243□PA-SG10 CMK243□PA-SG18 CMK243□PA-SG36	PK243□1A-SG3.6 PK243□1A-SG7.2 PK243□1A-SG9 PK243□1A-SG10 PK243□1A-SG18 PK243□1A-SG36			
	CMK264□PA-SG3.6 CMK264□PA-SG7.2 CMK264□PA-SG9 CMK264□PA-SG10 CMK264□PA-SG18 CMK264□PA-SG36	PK264□2A-SG3.6 PK264□2A-SG7.2 PK264□2A-SG9 PK264□2A-SG10 PK264□2A-SG18 PK264□2A-SG36		CMD2120P	
	CMK223PAR15S7.2 CMK223PAR15S9 CMK223PAR15S10 CMK223PAR15S18 CMK223PAR15S36	PK223PAR15S7.2 PK223PAR15S9 PK223PAR15S10 PK223PAR15S18 PK223PAR15S36			CMD2109P
	CMK243PAR15S3.6 CMK243PAR16S3.6 CMK243PAR25S3.6 CMK243PAR26S3.6	PK243A1AR15S3.6 PK243A1AR16S3.6 PK243A1AR25S3.6 PK243A1AR26S3.6			
	CMK243PAR15S7.2 CMK243PAR16S7.2 CMK243PAR25S7.2 CMK243PAR26S7.2	PK243A1AR15S7.2 PK243A1AR16S7.2 PK243A1AR25S7.2 PK243A1AR26S7.2			
	CMK243PAR15S9 CMK243PAR16S9 CMK243PAR25S9 CMK243PAR26S9	PK243A1AR15S9 PK243A1AR16S9 PK243A1AR25S9 PK243A1AR26S9			
	CMK243PAR15S10 CMK243PAR16S10 CMK243PAR25S10 CMK243PAR26S10	PK243A1AR15S10 PK243A1AR16S10 PK243A1AR25S10 PK243A1AR26S10			
	CMK243PAR15S18 CMK243PAR16S18 CMK243PAR25S18 CMK243PAR26S18	PK243A1AR15S18 PK243A1AR16S18 PK243A1AR25S18 PK243A1AR26S18			
	CMK243PAR15S36 CMK243PAR16S36 CMK243PAR25S36 CMK243PAR26S36	PK243A1AR15S36 PK243A1AR16S36 PK243A1AR25S36 PK243A1AR26S36			
	CMK264PAR15S3.6 CMK264PAR16S3.6 CMK264PAR25S3.6 CMK264PAR26S3.6	PK264A2AR15S3.6 PK264A2AR16S3.6 PK264A2AR25S3.6 PK264A2AR26S3.6	CMD2120P		
	CMK264PAR15S7.2 CMK264PAR16S7.2 CMK264PAR25S7.2 CMK264PAR26S7.2	PK264A2AR15S7.2 PK264A2AR16S7.2 PK264A2AR25S7.2 PK264A2AR26S7.2			
CMK264PAR15S9 CMK264PAR16S9 CMK264PAR25S9 CMK264PAR26S9	PK264A2AR15S9 PK264A2AR16S9 PK264A2AR25S9 PK264A2AR26S9				
CMK264PAR15S10 CMK264PAR16S10 CMK264PAR25S10 CMK264PAR26S10	PK264A2AR15S10 PK264A2AR16S10 PK264A2AR25S10 PK264A2AR26S10				
CMK264PAR15S18 CMK264PAR16S18 CMK264PAR25S18 CMK264PAR26S18	PK264A2AR15S18 PK264A2AR16S18 PK264A2AR25S18 PK264A2AR26S18				
CMK264PAR15S36 CMK264PAR16S36 CMK264PAR25S36 CMK264PAR26S36	PK264A2AR15S36 PK264A2AR16S36 PK264A2AR25S36 PK264A2AR26S36				

● Enter **A** (single shaft) or **B** (double shaft) in the box (□) within the model name.
 * If you are purchasing only a motor for maintenance purpose, etc., a connection cable will not be supplied. They must be purchased separately.
 They are available as accessories.
 Connection Cable → Page A-406

Introduction	AC Input Motor & Driver	DC Input Motor & Driver	Motor Only	Controllers	Accessories
AR	0.36° / Geared	0.36° / Geared	PK	SCX10	
AS	0.72° / Geared	0.36° / Geared	PK	EMP400	
ASX	0.9° / Geared	0.36° / Geared	PK	SG8030J	
CRK	1.8° / Geared	0.36° / Geared	PK		
CMK	1.8° / Geared	0.36° / Geared	PK/PV		
RBK	1.8° / Geared	0.36° / Geared	PK		