

aerospace
climate control
electromechanical
filtration
fluid & gas handling
hydraulics
pneumatics
process control
sealing & shielding

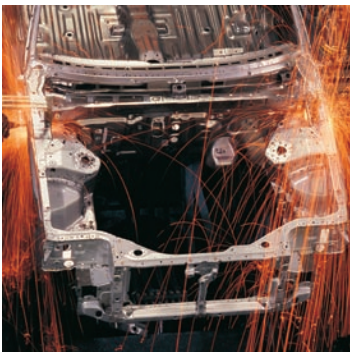

Extreme Force Electromechanical Cylinder

Series XFC

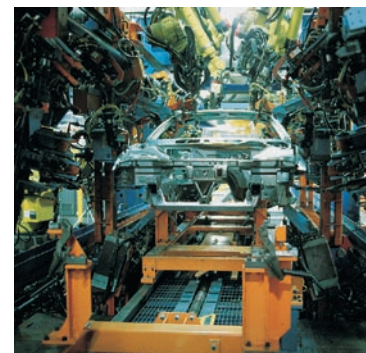

ENGINEERING YOUR SUCCESS.

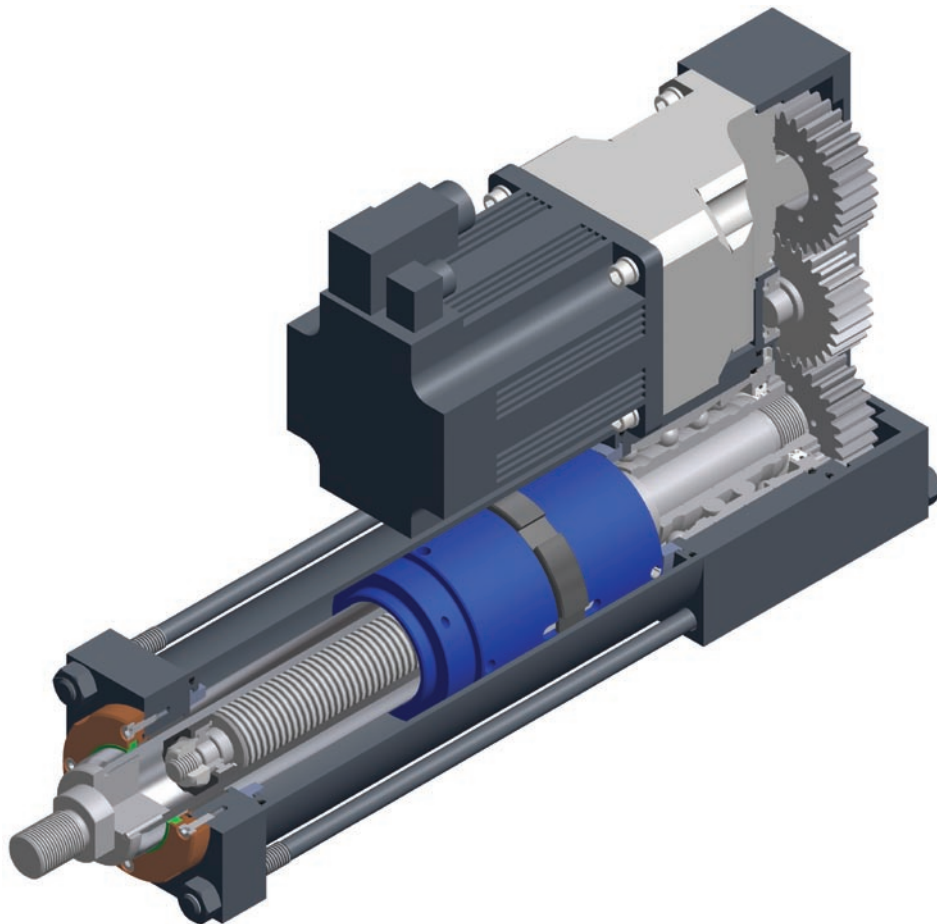

Provide machinery builders with a High Force Electromechanical cylinder solution yielding high durability, long life, minimal maintenance, and low operating cost by utilizing heavy duty steel construction and high load capacity roller screws combined with Parker's premier customer service.

Frame Size	Force (kN)	Force (lbs.)
XFC075	20.0	4,500
XFC090	33.4	7,500
XFC115	53.4	12,000
XFC140	80.0	17,500
XFC165	120.0	26,500
XFC190	178.0	40,000

⚠ Warning

FAILURE OR IMPROPER SELECTION OR IMPROPER USE OF THE PRODUCTS AND/OR SYSTEMS DESCRIBED HEREIN OR RELATED ITEMS CAN CAUSE DEATH, PERSONAL INJURY AND PROPERTY DAMAGE.

This document and other information from Parker Hannifin Corporation, its subsidiaries and authorized distributors provide product and/or system options for further investigation by users having technical expertise. It is important that you analyze all aspects of your application, including consequences of any failure and review the information concerning the product or system in the current product catalog. Due to the variety of operating conditions and applications for these products or systems, the user, through its own analysis and testing, is solely responsible for making the final selection of the products and systems and assuring that all performance, safety and warning requirements of the application are met.

The product described herein, including without limitation, product features, specifications, designs, availability and pricing, are subject to change by Parker Hannifin Corporation and its subsidiaries at any time without notice.

Offer of Sale

The items described in this document are hereby offered for sale by Parker Hannifin Corporation, its subsidiaries or its authorized distributors. This offer and its acceptance are governed by provisions stated on a separate page of the document entitled 'Offer of Sale'.



Features	Benefits
All Steel Construction	High Durability
Elastomeric Seals Throughout	Completely Sealed (No Gaskets used)
Standard Metric Hydraulic Type Tie Rod Construction	Structural Rigidity
Opposed Preloaded Angular Contact Bearings	Increased Accuracy and Durability Bi-Directional Force Capabilities
Roller Screw Drive System	Increased Load, Life, and Shock Loading Capabilities compared to traditional Ball Screw designs
Inline and Parallel Gear Drive Configurations	Positive Engagement between Motor and Load No Belts to Break or Skip Teeth
Speeds up to 40 Inches per Second	Cycle Time Reduction
178kN Continuous Thrust (40,000 Pounds)	Hydraulic Replacement Capabilities
Parker Bayside Stealth Gearhead Direct Mount	Standard Reduction options from 3:1 – 10:1 Higher Ratios up to 100:1 Available
Parker MPP Max Plus Plus Motors Standard	Complete Parker System Solution (Cylinder, Gearhead, Motor, Drive, Controls)
No “Standard” Stroke Lengths (Order in mm increments)	No Added Cost for Stroke not required

Parker Hannifin's Latest Electromechanical Extreme Force Cylinder

The Series XFC Roller Screw Cylinder

Parker is pleased to introduce a new level of Electric High Thrust cylinders featuring roller screw drive technology – Series XFC. The Series XFC Extreme Force Electromechanical Cylinder is designed to provide heavy machine builders a high force electromechanical solution offering long life, minimal maintenance and low operating costs while maintaining structural rigidity. All this while still providing world class customer service and industry leading delivery times.

As a worldwide leader in fluid power cylinder products, Parker has combined the best of both worlds into one unique product. All the benefits of electromechanical control and cleanliness combined with the structural rigidity and durability of a traditional hydraulic tie rod cylinder.

Flexibility & Programmability:

In applications where high loads and/or high speed motion are required, roller screws offer a very attractive solution. Servo Motors and controls feature simplified programming with auto-tuning capabilities reducing installation start up time and expenses.

Electromechanical control systems utilizing servo motor technology provide infinite programmability along with some advantages not easily obtainable with other solutions such as multiple move profiles, adjustable acceleration and deceleration, force control, and absolute positioning capabilities. These features allow the system to be easily adaptable to changing application conditions and performance requirements with minimal modification.

Maintenance & Installation:

Roller screw cylinder systems require little or no maintenance when compared to their fluid power alternatives while still delivering long life and high performance. Due to the small number of components required for a complete system, the commissioning time required for operation is significantly reduced. This allows system builders to quickly install, troubleshoot, and test system capabilities faster and more reliably than other alternatives.

Environmental Considerations:

With electromechanical system technology, fluid leaks, filter changes, and air bleeding are a thing of the past. Simply mount the cylinder, plug in the cables, download a program and you are up and running in record time.

Anti-Rotation:

As a result of the steel round body cylinder design, internal anti-rotation of the thrust tube is not available in Series XFC Cylinders. Applications must be designed to prevent thrust tube rotation during operation. Refer to performance overview charts for torque values.

Parker's Capabilities:

With Hydraulic, Pneumatic, and now Electromechanical technologies Parker can provide the best solution for a specific application regardless of requirements with an unmatched offering of cylinder products to more than 100 industrial markets worldwide.

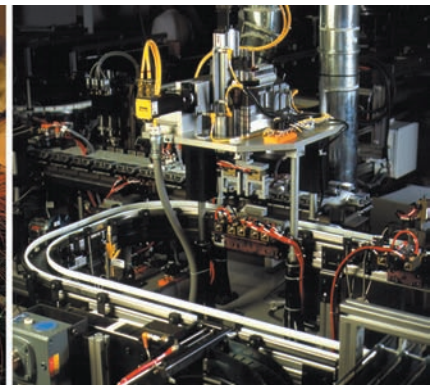
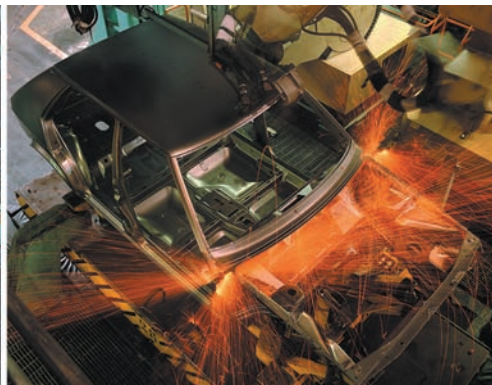

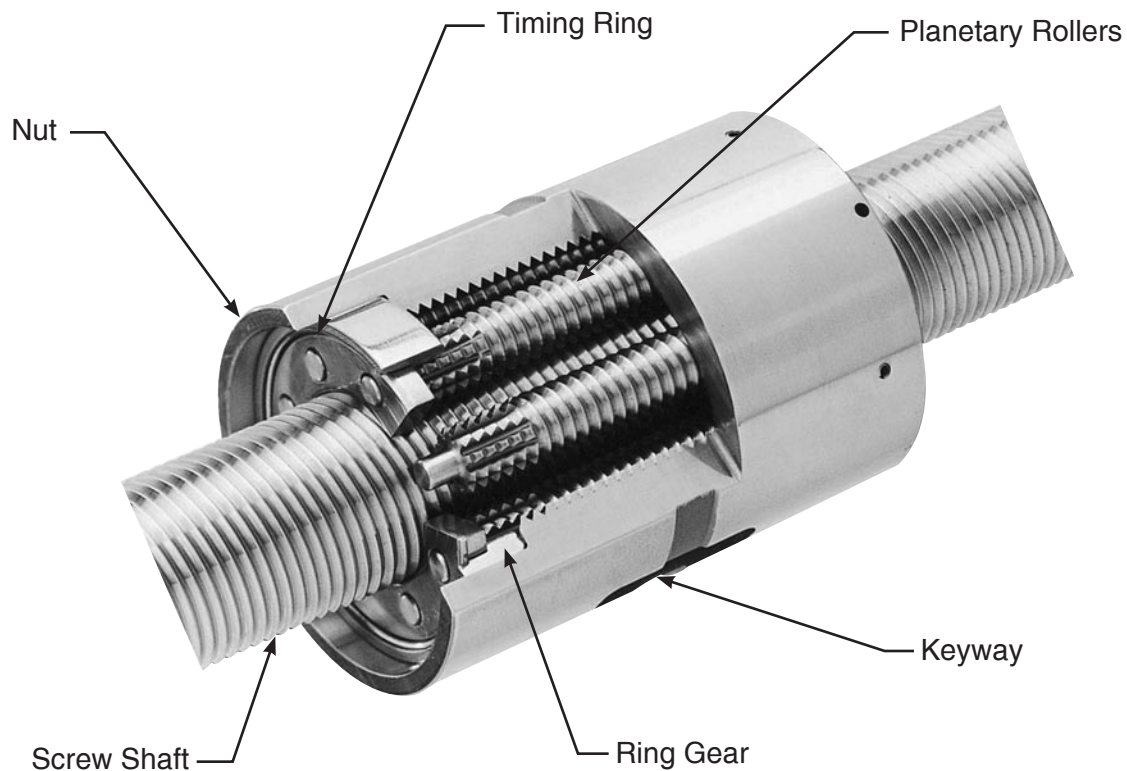

Roller Screw Technology

Planetary Roller Screws offer distinct benefits over more traditional Ball screw and Lead screw mechanisms, as well as added features not easily attainable with Hydraulic or Pneumatic Linear Motion.

The key to the Roller Screw design is in the utilization of planetary rollers in the place of Ball bearings as the primary rolling elements. The Rollers provide an increased number of contact surfaces between the external shaft of the screw and the internal threads of the roller nut. In simple terms the increased number of contact points between the screw and the nut allow increased load carrying capabilities, higher speeds, and increased life when compared to a similarly sized ball screw of the same size.

Roller Screw Advantages

Thrust Capacity and Life:

A Planetary Roller Screw transmits rotary motion into linear motion very similarly to a ball or lead screw but, due to the increased number of contact points the roller screw does so with an increased thrust capacity and greatly increased life. These increases are generally a 5 times increase in thrust and a 10 times increase in life over a traditional ball screw.

XFC Model Code

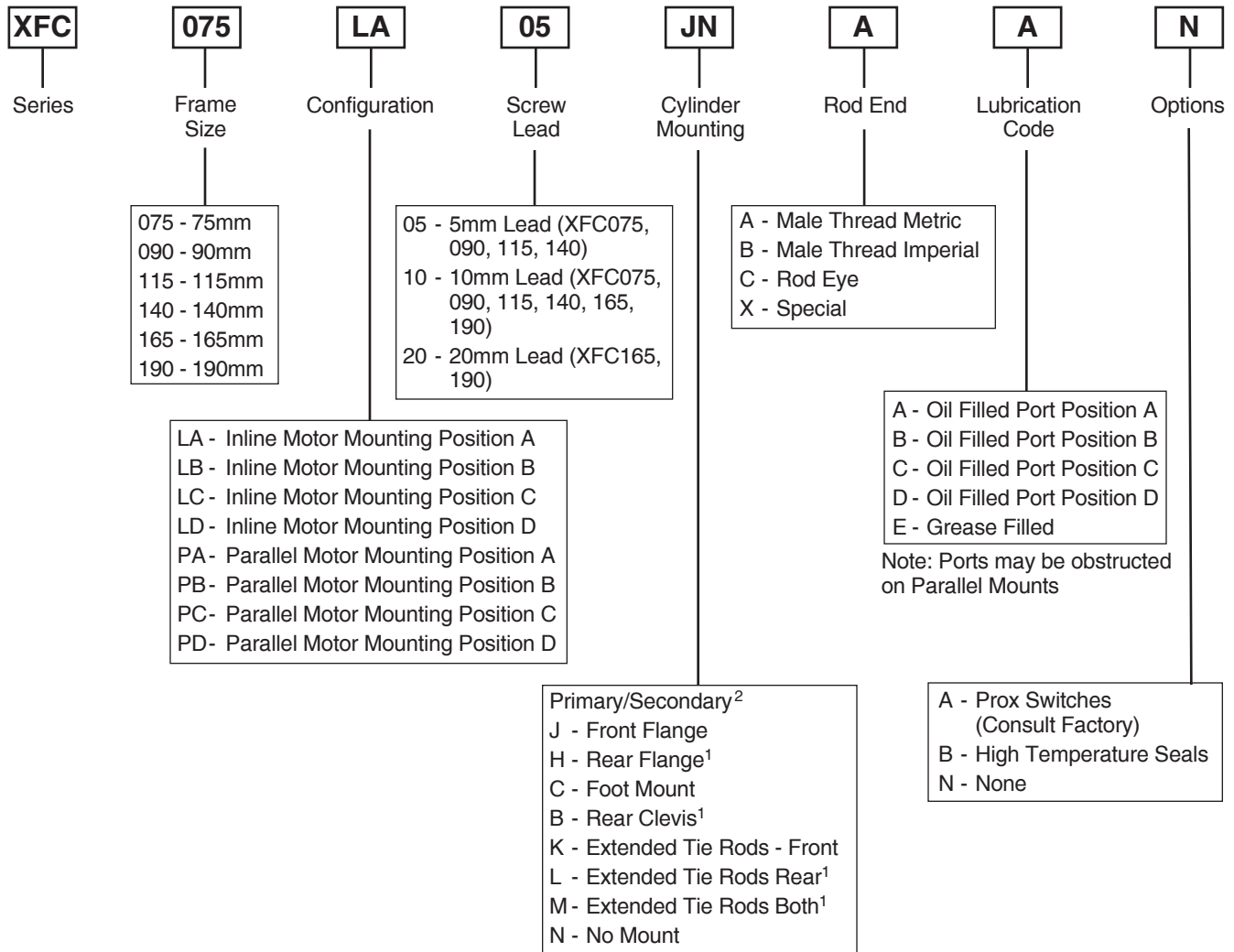

¹Parallel Mounting Only

²Primary Mount should be excluded from Secondary Mount Option

Motor Mounting and Port Positions

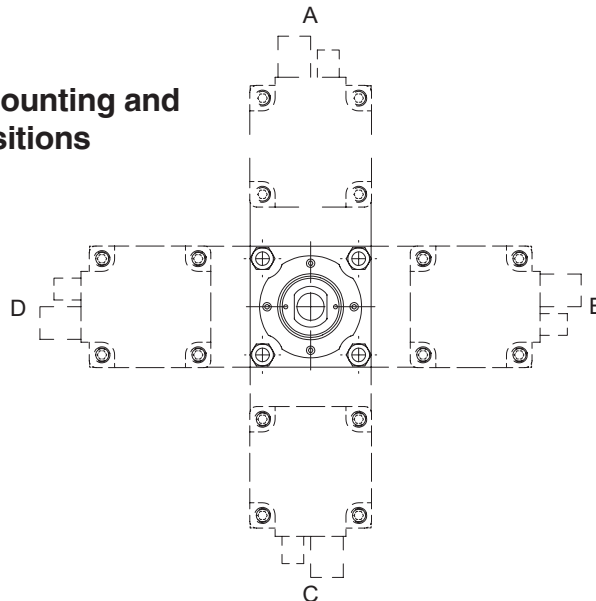

XFC Model Code

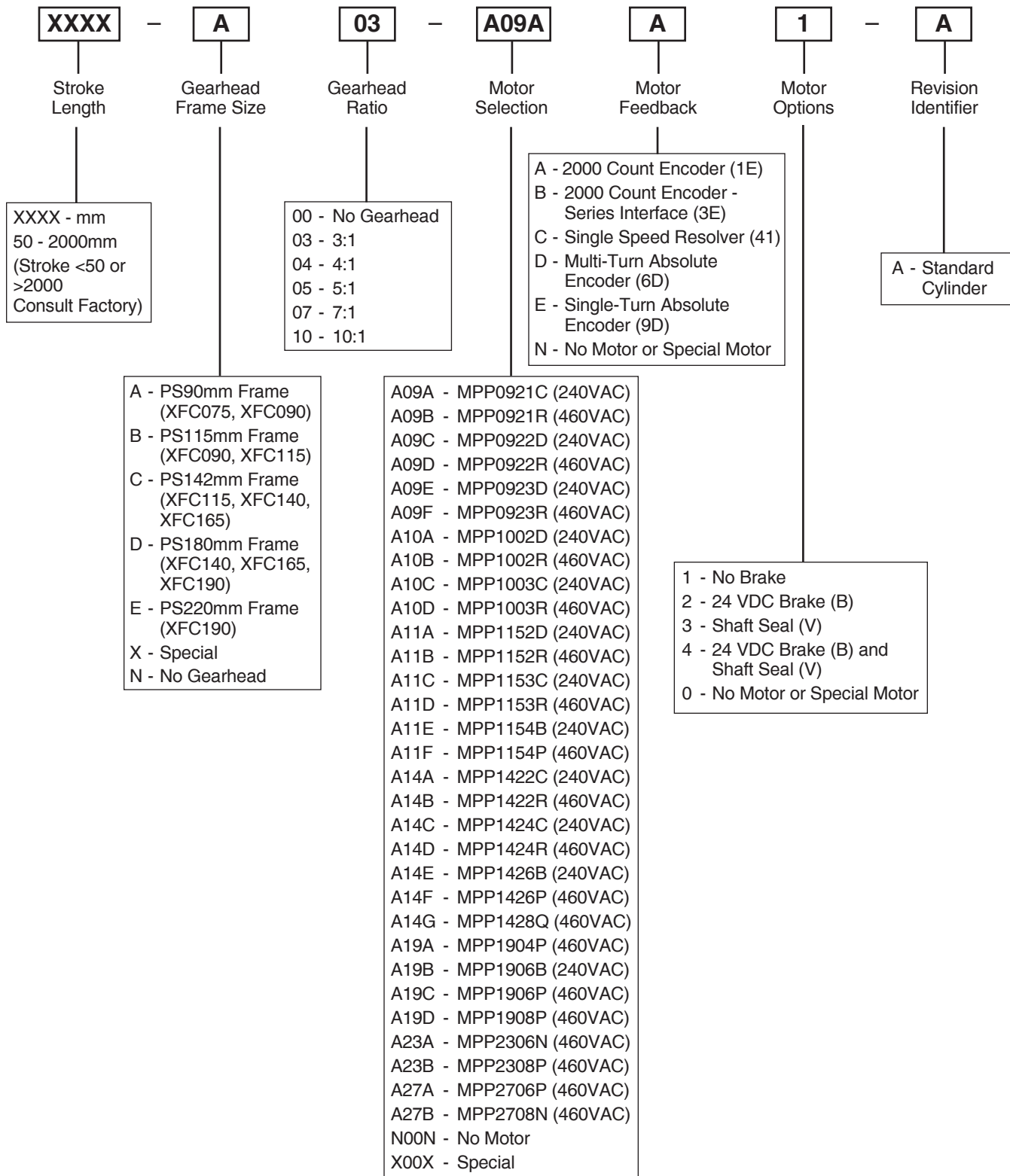

Performance Overview

Frame Size	XFC075	XFC090	XFC115	XFC140	XFC165	XFC190
Continuous Thrust kN (lbs)	20 (4,500)	34 (7,500)	54 (12,000)	80 (17,500)	120 (26,500)	178 (40,000)
Maximum Thrust kN (lbs)	40 (9,000)	68 (15,000)	108 (24,000)	160 (35,000)	240 (53,000)	356 (80,000)
Maximum Acceleration mm/sec ² (in/sec ²)	19,600 (773)	19,600 (773)	19,600 (773)	19,600 (773)	19,600 (773)	19,600 (773)
Maximum Stroke mm (in) ¹	2,000 (78.75)	2,000 (78.75)	2,000 (78.75)	2,000 (78.75)	2,000 (78.75)	2,000 (78.75)
Suggested Maximum Stroke Lengths of Unsupported Cylinders ³	750 (29.53)	750 (29.53)	750 (29.53)	1,000 (39.37)	1,000 (39.37)	1,250 (49.21)

System Characteristics

Frame Size	XFC075	XFC090	XFC115	XFC140	XFC165	XFC190
Accuracy mm (in)	0.08 (0.003)	0.08 (0.003)	0.08 (0.003)	0.08 (0.003)	0.13 (0.005)	0.13 (0.005)
Repeatability mm (in)	0.03 (0.001)	0.03 (0.001)	0.03 (0.001)	0.03 (0.001)	0.05 (0.002)	0.05 (0.002)
Backlash mm (in)	0.03 (0.001)	0.03 (0.001)	0.03 (0.001)	0.03 (0.001)	0.03 (0.001)	0.03 (0.001)

Screw Properties

Size	Screw Diameter	Lead ²	Efficiency	Ca Rating	Thrust Tube Torque	Max. Speed mm/sec
XFC075	21mm	5mm/rev (0.197 in/rev)	88.78%	40.4 kN (9,082 lbf)	.035 lb-in/lbf	508
		10mm/rev (0.394 in/rev)	91.17%	44.6 kN (10,026 lbf)	.069 lb-in/lbf	1016
XFC090	30mm	5mm/rev (0.197 in/rev)	87.05%	73.6 kN (16,546 lbf)	.036 lb-in/lbf	356
		10mm/rev (0.394 in/rev)	90.38%	74.4 kN (16,726 lbf)	.069 lb-in/lbf	712
XFC115	39mm	5mm/rev (0.197 in/rev)	85.18%	103.4 kN (23,245 lbf)	.037 lb-in/lbf	274
		10mm/rev (0.394 in/rev)	89.37%	116.5 kN (26,190 lbf)	.070 lb-in/lbf	548
XFC140	48mm	5mm/rev (0.197 in/rev)	82.50%	158.5 kN (35,632 lbf)	.038 lb-in/lbf	222
		10mm/rev (0.394 in/rev)	88.34%	171.2 kN (38,487 lbf)	.071 lb-in/lbf	444
XFC165	60mm	10mm/rev (0.394 in/rev)	87.05%	238.6 kN (53,639 lbf)	.072 lb-in/lbf	356
		20mm/rev (0.787 in/rev)	90.38%	238.6 kN (53,639 lbf)	.139 lb-in/lbf	712
XFC190	75mm	10mm/rev (0.394 in/rev)	85.45%	356.5 kN (80,144 lbf)	.073 lb-in/lbf	284
		20mm/rev (0.787 in/rev)	90.97%	356.5 kN (80,144 lbf)	.144 lb-in/lbf	568

¹ Consult factory for non-standard stroke lengths² Consult factory for non-standard leads³ Secondary support required for longer stroke lengths (consult factory)

Calculations

Thrust Calculations

Calculate the thrust generated by the application. Total thrust generally consists of three components:

Acceleration Thrust $F_a = L/g \times V/T_a$

Thrust Due to Gravity $F_g = L \sin \alpha$
(Horizontal applications do not apply.)

Thrust Due to Friction $F_f = \mu_s L \cos \alpha$

Total Thrust = $F_t = F_a + F_g + F_f$

Terms used:

- F_t = Total (maximum) Thrust Force (N, lb)
- F_f = Friction Force (N, lb)
- F_g = Force of Gravity (N, lb)
- F_a = Acceleration Thrust (N, lb)
- α = Angle of Inclination (see illustration below)
- μ_s = Coefficient of Sliding Friction
- L = Actual Weight (N, lb)
- g = Acceleration due to Gravity (9800 mm/sec², 386 in/sec²)
- V = Velocity (mm/sec, inch/sec)
- T_a = Acceleration Time (sec)
- D = Move Distance (mm, in)
- t = Move Time (sec)
- A = Acceleration (mm/sec², inch/sec²)

Cylinder Orientation

The terms used and their values depend upon the orientation of the cylinder. Refer to the illustrations and equations below to determine the form of the thrust equation.

Horizontal

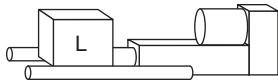

Horizontal Equation

$F_t = F_a + F_f$

Vertical

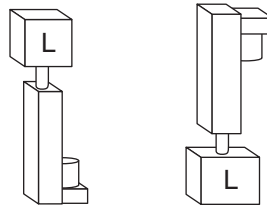

Vertical Equations

Upward

$F_t = F_a + F_g + F_f$

Downward

$F_t = F_a - F_g + F_f$

Angular

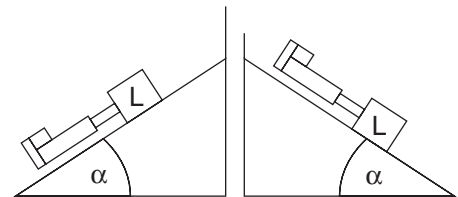

Angular Equations

Upward

$F_t = F_a + F_g + F_f$

Downward

$F_t = F_a - F_g + F_f$

Motor Speed Calculation

Speed = $\frac{V_L \times \text{Ratio}}{\text{Lead}}$

Where:

- Lead** = Screw lead (mm/rev)
- V_L** = Maximum linear velocity in mm/s (in/sec)
- Ratio** = Reduction ratio, if any (i.e. 2:1, Ratio = 2)
- Speed** = Required motor speed in rev/sec

Calculations

Motor Torque Calculations

$$T = \frac{\text{Thrust} \times \text{Lead}}{\eta_s \times \eta_b \times 2\pi \times \text{Ratio}}$$

Where:

T = Input torque required, Nm (in-lb)

Lead = Screw lead (in/Rev)

Thrust = Calculated thrust value in N (lbf)

$$= F_a + F_g + F_f$$

F_a (Acceleration Thrust)

$$= \text{Load} / (9800\text{mm/sec}^2) \times \text{Velocity/Acceleration Time}$$

F_g (Force of Gravity) = Load \times sin α

F_f (Friction Force) = $\mu_s \times$ Load \times cos α

η_b = Gear Efficiency Coefficient:

for parallel driven versions, typically 0.95 (or 95%)

for inline versions use 1.0

η_s = Screw Efficiency Coefficient

Ratio = Drive Ratio (if reducer is used)

Friction Coefficients μ_s

Material (dry contact unless noted)	μ_s
Steel on steel	0.80
Steel on steel (lubricated)	0.16
Aluminum on steel	0.45
Copper on steel	0.22
Brass on steel	0.35
PTFE on steel	0.04

Trapezoidal Motion Profile

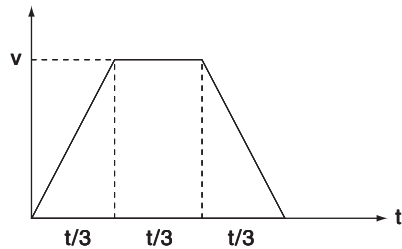

$$V = 1.5 \times D/t$$

$$A = 4.5 \times D/t^2$$

Triangular Motion Profile

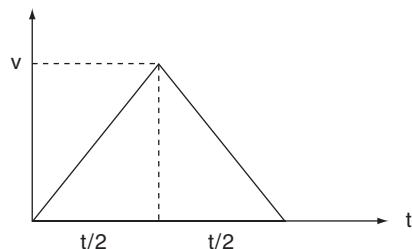

$$V = 2 \times D/t$$

$$A = 4 \times D/t^2$$

Acceleration $\leq 1 g (9.8 \text{ m/sec}^2)$

Life Calculations (Millions of Revolutions)

$$L_{10} = \left(\frac{C_a}{F_m} \right)^3$$

L_{10} = Life (Millions of Revolutions)

C_a = Basic Dynamic Load Rating

F_m = Cubic Mean Load

$$F_m = \frac{F_{\min} + 2F_{\max}}{3}$$

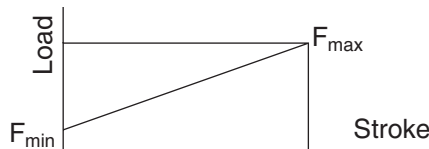

Inline – “T” Basic and Extended Tie Rod Mounts

Cylinders with extended Tie Rods are suitable for straight line force applications, and are particularly useful where space is limited.

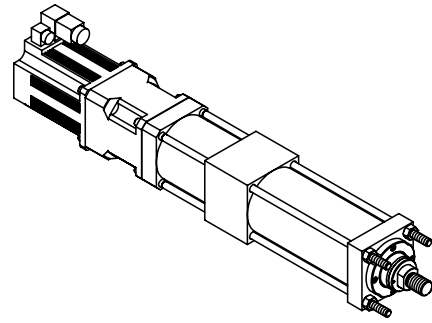

Inline – “J” Integral Front Flange Mount

These cylinders are suitable for use on straight line force transfer applications.

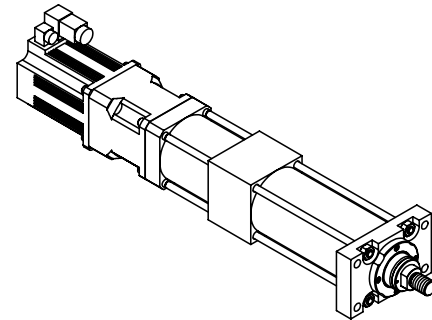

Inline – “C” Foot Mount

Foot mounted cylinders do not absorb forces along their centerline. As a result, the application of force by the cylinder produces a moment which attempts to rotate the cylinder about its mounting bolts. It is therefore very important that the cylinder be firmly secured to the mounting surface and the load should be rigidly guided to avoid side loads being applied to the cylinder bearings.

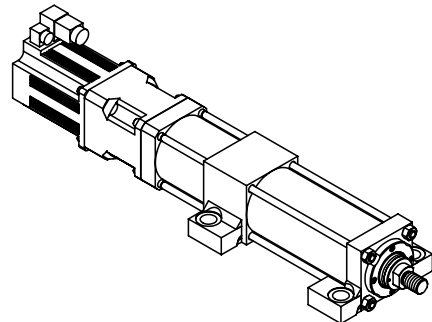

Parallel – “H” Rear Flange Mount

These cylinders are suitable for use on straight line force transfer applications.

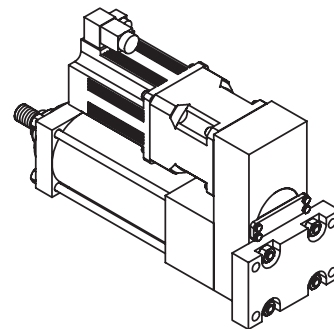

Parallel – “T” Basic and Extended Tie Rod Mounts

Cylinders with extended Tie Rods are suitable for straight line force applications, and are particularly useful where space is limited.

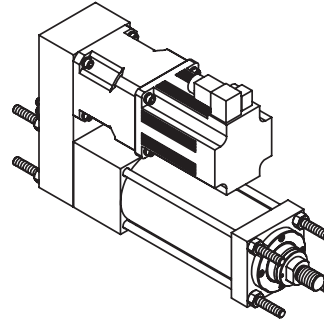

Parallel – “J” Integral Front Flange Mount

These cylinders are also suitable for use on straight line force transfer applications.

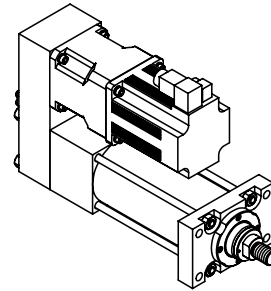

Parallel – “C” Foot Mount

Foot mounted cylinders do not absorb forces along their centerline. As a result, the application of force by the cylinder produces a moment which attempts to rotate the cylinder about its mounting bolts. It is therefore very important that the cylinder be firmly secured to the mounting surface and the load should be rigidly guided to avoid side loads being applied to the cylinder bearings.

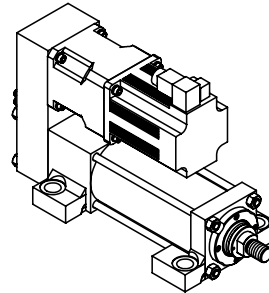

Parallel – “BB” Rear Clevis Mount

Cylinders with pivot mountings, which absorb forces on their centerlines should be used where the machine member to be moved travels in a curved path. Pivot mountings may be used in tension (pull) or compression (push) applications. Cylinders using a fixed clevis may be used if the curved path of the thrust tube travels in a single plane.

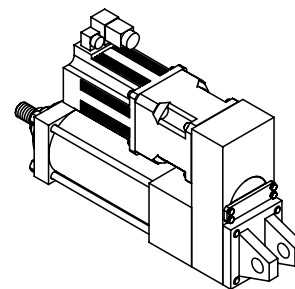

Inline “T” Basic and “K” Extended Tie Rod Mounts

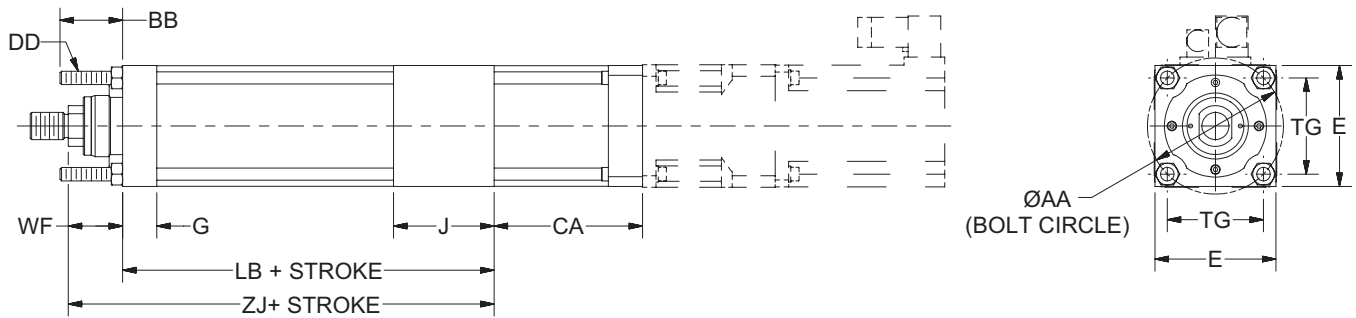

	ØAA	BB	DD	E	G
75	83 (3.27)	30 (1.18)	M8x1	76.2 (3.00)	22 (0.87)
90	100 (3.94)	35 (1.38)	M10x1.5	88.9 (3.50)	25 (0.98)
115	127 (5.00)	40 (1.57)	M12x1.25	114.3 (4.50)	30 (1.18)
140	155 (6.10)	50 (1.97)	M16x1.5	139.7 (5.50)	35 (1.38)
165	185 (7.28)	60 (2.36)	M16x1.5	165.1 (6.50)	40 (1.57)
190	215 (8.46)	75 (2.95)	M22x1.5	190.5 (7.50)	50 (1.97)

	J	TG	WF	+ STROKE	
				LB	ZJ
75	62 (2.44)	58.69 (2.311)	38 (1.496)	205.5 (8.09)	243.5 (9.59)
90	74 (2.91)	70.71 (2.784)	40 (1.575)	248.0 (9.76)	288.0 (11.34)
115	91 (3.58)	89.80 (3.535)	45 (1.772)	293.0 (11.54)	338.0 (13.31)
140	108 (4.25)	109.60 (4.315)	45 (1.772)	348.0 (13.70)	393.0 (15.47)
165	123 (4.84)	130.81 (5.150)	60 (2.362)	417.0 (16.42)	477.0 (18.78)
190	152 (5.98)	152.03 (5.985)	62 (2.441)	503.0 (19.80)	565.0 (22.24)

Frame Size	Motor or Gearhead	CA
XFC075	PS090	113 (4.45)
	PS115	115 (4.53)
	MPP115	98 (3.86)
	MPP142	109 (4.29)
XFC090	PS090	115 (4.53)
	PS115	117 (4.61)
	MPP115	100 (3.94)
	MPP142	111 (4.37)
XFC115	PS115	130 (5.12)
	PS142	158 (6.22)
	MPP142	113 (4.45)
	MPP190	136 (5.35)

Frame Size	Motor or Gearhead	CA
XFC140	PS142	161 (6.34)
	PS180	190 (7.48)
	MPP190	139 (5.47)
	MPP230	173 (6.81)
XFC165	PS142	164 (6.46)
	PS180	193 (7.60)
	MPP230	176 (6.93)
	MPP270	183 (7.20)
XFC190	PS180	194 (7.64)
	PS220	214 (8.43)

Parallel “T” Basic and “K” Extended Tie Rod Mounts

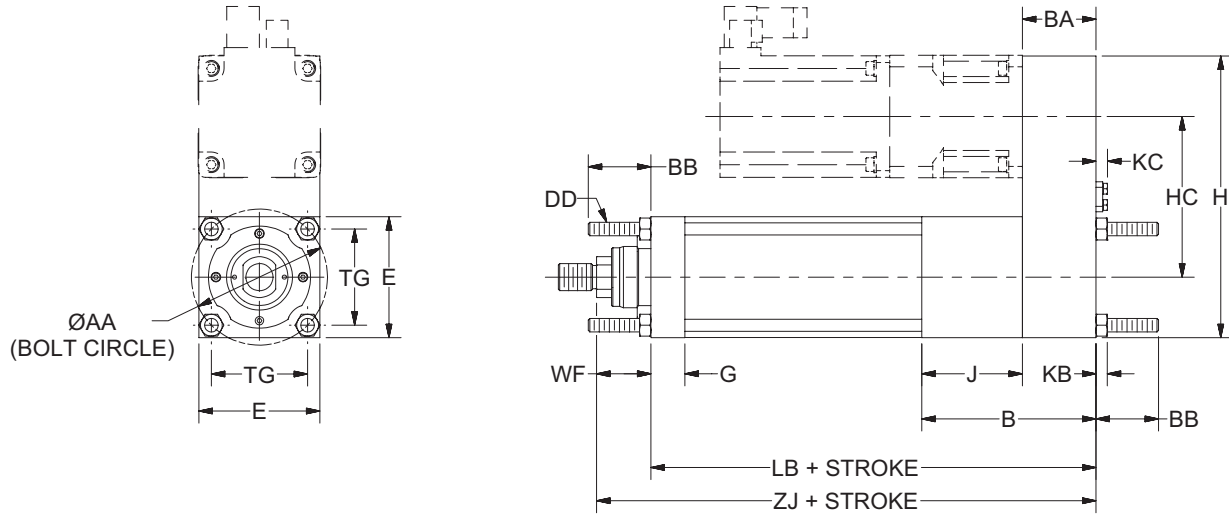

	ØAA	B	BA	BB	DD	E	G	H
75	83 (3.27)	106 (4.17)	44 (1.73)	30 (1.18)	M8x1	76.2 (3.00)	22 (0.87)	174.2 (6.86)
90	100 (3.94)	128 (5.04)	54 (2.13)	35 (1.38)	M10x1.5	88.9 (3.50)	25 (0.98)	206.9 (8.15)
115	127 (5.00)	154 (6.06)	63 (2.48)	40 (1.57)	M12x1.25	114.3 (4.50)	30 (1.18)	271.0 (10.67)
140	155 (6.10)	180 (7.09)	72 (2.83)	50 (1.97)	M16x1.5	139.7 (5.50)	35 (1.38)	332.2 (13.08)
165	185 (7.28)	211 (8.31)	88 (3.46)	60 (2.36)	M16x1.5	165.1 (6.50)	40 (1.57)	379.1 (14.93)
190	215 (8.46)	252 (9.92)	100 (3.94)	75 (2.95)	M22x1.5	190.5 (7.50)	50 (1.97)	455.5 (17.93)

	HC	J	KB	KC	TG	WF	+ STROKE	
							LB	ZJ
75	98 (3.86)	62 (2.44)	6.5 (0.26)	6.93 (0.27)	58.69 (2.311)	38 (1.496)	249.5 (9.82)	287.5 (11.32)
90	118 (4.65)	74 (2.91)	8.0 (0.31)	8.65 (0.34)	70.71 (2.784)	40 (1.575)	302.0 (11.89)	342.0 (13.46)
115	156 (6.14)	91 (3.58)	10.0 (0.39)	10.15 (0.40)	89.80 (3.535)	45 (1.772)	356.0 (14.02)	401.0 (15.79)
140	193 (7.58)	108 (4.25)	13.0 (0.51)	13.65 (0.54)	109.60 (4.315)	45 (1.772)	420.0 (16.54)	465.0 (18.31)
165	224 (8.82)	123 (4.84)	13.0 (0.51)	13.65 (0.54)	130.81 (5.150)	60 (2.362)	505.0 (19.88)	565.0 (22.24)
190	265 (10.43)	152 (5.98)	18.0 (0.71)	17.18 (0.68)	152.03 (5.985)	62 (2.441)	603.0 (23.74)	665.0 (26.18)

Inline “J” Mount

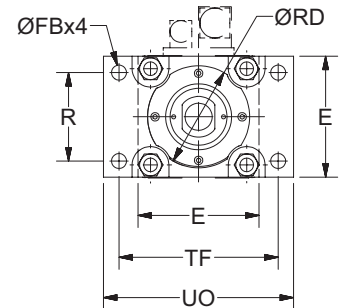
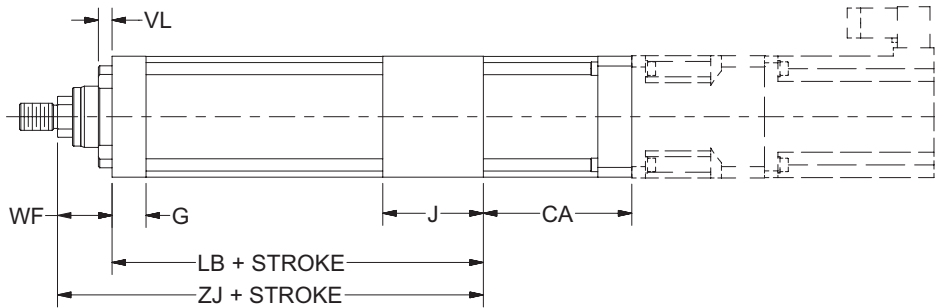

	E	ØFB	G	J	R	ØRD f8
75	76.2 (3.000)	9 (0.354)	22 (0.87)	62 (2.44)	52 (2.047)	65 (2.559)
90	88.9 (3.500)	11 (0.433)	25 (0.98)	74 (2.91)	65 (2.559)	75 (2.953)
115	114.3 (4.500)	14 (0.551)	30 (1.18)	91 (3.58)	83 (3.268)	95 (3.740)
140	139.7 (5.500)	18 (0.709)	35 (1.38)	108 (4.25)	107 (4.213)	110 (4.331)
165	165.1 (6.500)	18 (0.709)	40 (1.57)	123 (4.84)	126 (4.961)	135 (5.315)
190	190.5 (7.500)	22 (0.866)	50 (1.97)	152 (5.98)	155 (6.102)	155 (6.102)

	TF	UO	VL	WF	+ STROKE	
					LB	ZJ
75	105 (4.134)	125.0 (4.92)	10 (0.394)	38 (1.496)	205.5 (8.09)	243.5 (9.59)
90	117 (4.606)	139.7 (5.50)	10 (0.394)	40 (1.575)	248.0 (9.76)	288.0 (11.34)
115	149 (5.866)	175.0 (6.89)	12 (0.472)	45 (1.772)	293.0 (11.54)	338.0 (13.31)
140	172 (6.772)	210.0 (8.27)	12 (0.472)	45 (1.772)	348.0 (13.70)	393.0 (15.47)
165	208 (8.189)	250.0 (9.84)	14 (0.551)	60 (2.362)	417.0 (16.42)	477.0 (18.78)
190	253 (9.961)	300.0 (11.81)	16 (0.630)	62 (2.441)	503.0 (19.80)	565.0 (22.24)

Frame Size	Motor or Gearhead	CA
XFC075	PS090	113 (4.45)
	PS115	115 (4.53)
	MPP115	98 (3.86)
	MPP142	109 (4.29)
XFC090	PS090	115 (4.53)
	PS115	117 (4.61)
	MPP115	100 (3.94)
	MPP142	111 (4.37)
XFC115	PS115	130 (5.12)
	PS142	158 (6.22)
	MPP142	113 (4.45)
	MPP190	136 (5.35)

Frame Size	Motor or Gearhead	CA
XFC140	PS142	161 (6.34)
	PS180	190 (7.48)
	MPP190	139 (5.47)
	MPP230	173 (6.81)
XFC165	PS142	164 (6.46)
	PS180	193 (7.60)
	MPP230	176 (6.93)
	MPP270	183 (7.20)
XFC190	PS180	194 (7.64)
	PS220	214 (8.43)

Parallel “J” Mount

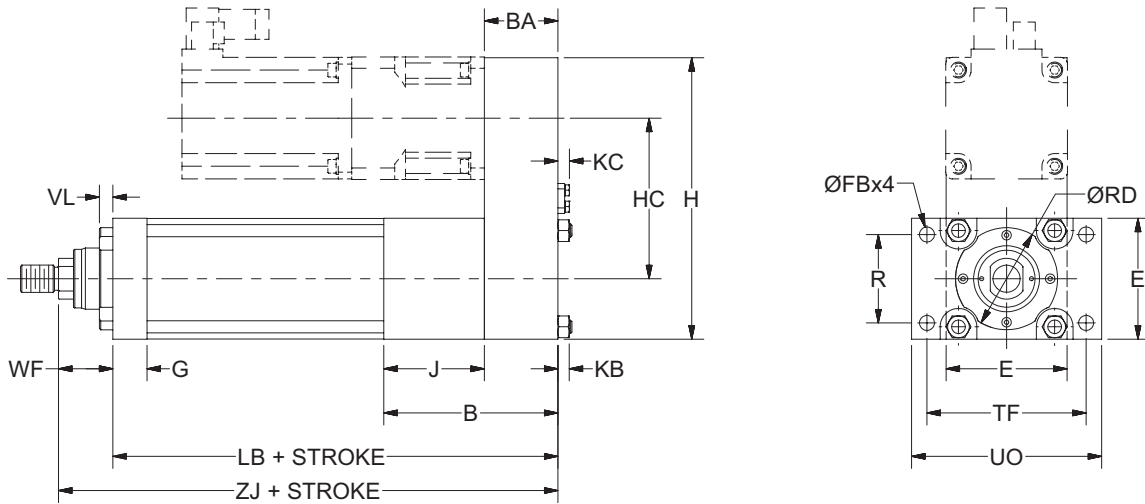

	B	BA	E	FB	G	H	HC	J	KB
75	106 (4.17)	44 (1.73)	76.2 (3.000)	9 (0.354)	22 (0.87)	174.2 (6.86)	98.0 (3.86)	62 (2.44)	6.5 (0.26)
90	128 (5.04)	54 (2.13)	88.9 (3.500)	11 (0.433)	25 (0.98)	206.9 (8.15)	118.0 (4.65)	74 (2.91)	8.0 (0.31)
115	154 (6.06)	63 (2.48)	114.3 (4.500)	14 (0.551)	30 (1.18)	271.0 (10.67)	156.0 (6.14)	91 (3.58)	10.0 (0.39)
140	180 (7.09)	72 (2.83)	139.7 (5.500)	18 (0.709)	35 (1.38)	332.2 (13.08)	192.5 (7.58)	108 (4.25)	13.0 (0.51)
165	211 (8.31)	88 (3.46)	165.1 (6.500)	18 (0.709)	40 (1.57)	379.1 (14.93)	224.0 (8.82)	123 (4.84)	13.0 (0.51)
190	252 (9.92)	100 (3.94)	190.5 (7.500)	22 (0.866)	50 (1.97)	455.5 (17.93)	265.0 (10.43)	152 (5.98)	18.0 (0.71)

	KC	R	ØRD f8	TF	UO	VL	WF	+ STROKE	
								LB	ZJ
75	6.93 (0.27)	52 (2.047)	65 (2.559)	105 (4.134)	125.0 (4.921)	10 (0.394)	38 (1.496)	249.5 (9.82)	287.5 (11.32)
90	8.65 (0.34)	65 (2.559)	75 (2.953)	117 (4.606)	139.7 (5.500)	10 (0.394)	40 (1.575)	302.0 (11.89)	342.0 (13.46)
115	10.15 (0.40)	83 (3.268)	95 (3.740)	149 (5.866)	175.0 (6.890)	12 (0.472)	45 (1.772)	356.0 (14.02)	401.0 (15.79)
140	13.65 (0.54)	107 (4.213)	110 (4.331)	172 (6.772)	210.0 (8.268)	12 (0.472)	45 (1.772)	420.0 (16.54)	465.0 (18.31)
165	13.65 (0.54)	126 (4.961)	135 (5.315)	208 (8.189)	250.0 (9.843)	14 (0.551)	60 (2.362)	505.0 (19.88)	565.0 (22.24)
190	17.18 (0.68)	155 (6.102)	155 (6.102)	253 (9.961)	300.0 (11.811)	16 (0.630)	62 (2.441)	603.0 (23.74)	665.0 (26.18)

Inline “C” Mount

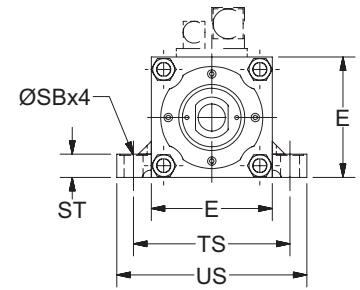
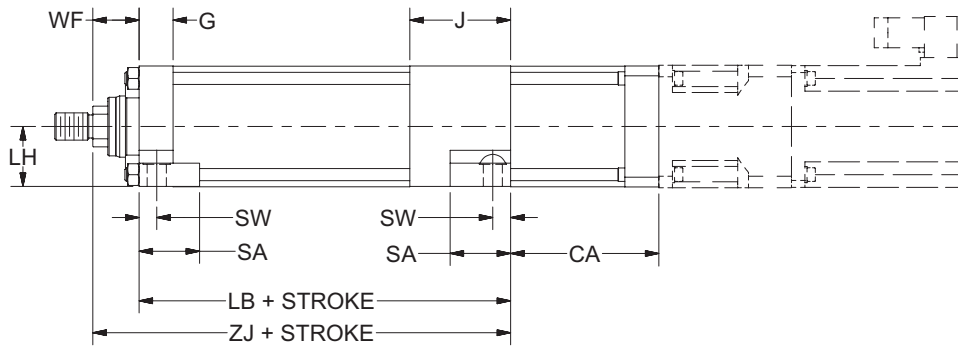

	E	G	J	LH h10	SA	ØSB	ST
75	76.2 (3.00)	22 (0.87)	62 (2.44)	38 (1.496)	33.32 (1.31)	11 (0.433)	11.11 (0.44)
90	88.9 (3.50)	25 (0.98)	74 (2.91)	44 (1.732)	44.45 (1.75)	14 (0.551)	17.46 (0.69)
115	114.3 (4.50)	30 (1.18)	91 (3.58)	57 (2.244)	57.15 (2.25)	18 (0.709)	23.81 (0.94)
140	139.7 (5.50)	35 (1.38)	108 (4.25)	69 (2.717)	57.15 (2.25)	18 (0.709)	23.81 (0.94)
165	165.1 (6.50)	40 (1.57)	123 (4.84)	82 (3.228)	73.03 (2.88)	22 (0.866)	30.16 (1.19)
190	190.5 (7.50)	50 (1.97)	152 (5.98)	95 (3.740)	92.08 (3.63)	26 (1.024)	36.51 (1.44)

	SW	TS	US	WF	+ STROKE	
					LB	ZJ
75	11 (0.433)	97 (3.819)	114.30 (4.50)	38 (1.496)	205.5 (8.09)	243.5 (9.59)
90	13 (0.512)	115 (4.528)	139.70 (5.50)	40 (1.575)	248.0 (9.76)	288.0 (11.34)
115	15 (0.591)	155 (6.102)	184.15 (7.25)	45 (1.772)	293.0 (11.54)	338.0 (13.31)
140	18 (0.709)	175 (6.890)	209.55 (8.25)	45 (1.772)	348.0 (13.70)	393.0 (15.47)
165	20 (0.787)	210 (8.268)	254.00 (10.00)	60 (2.362)	417.0 (16.42)	477.0 (18.78)
190	25 (0.984)	260 (10.236)	304.80 (12.00)	62 (2.441)	503.0 (19.80)	565.0 (22.24)

Frame Size	Motor or Gearhead	CA
XFC075	PS090	113 (4.45)
	PS115	115 (4.53)
	MPP115	98 (3.86)
	MPP142	109 (4.29)
XFC090	PS090	115 (4.53)
	PS115	117 (4.61)
	MPP115	100 (3.94)
	MPP142	111 (4.37)
XFC115	PS115	130 (5.12)
	PS142	158 (6.22)
	MPP142	113 (4.45)
	MPP190	136 (5.35)

Frame Size	Motor or Gearhead	CA
XFC140	PS142	161 (6.34)
	PS180	190 (7.48)
	MPP190	139 (5.47)
	MPP230	173 (6.81)
XFC165	PS142	164 (6.46)
	PS180	193 (7.60)
	MPP230	176 (6.93)
	MPP270	183 (7.20)
XFC190	PS180	194 (7.64)
	PS220	214 (8.43)

Parallel “C” Mount

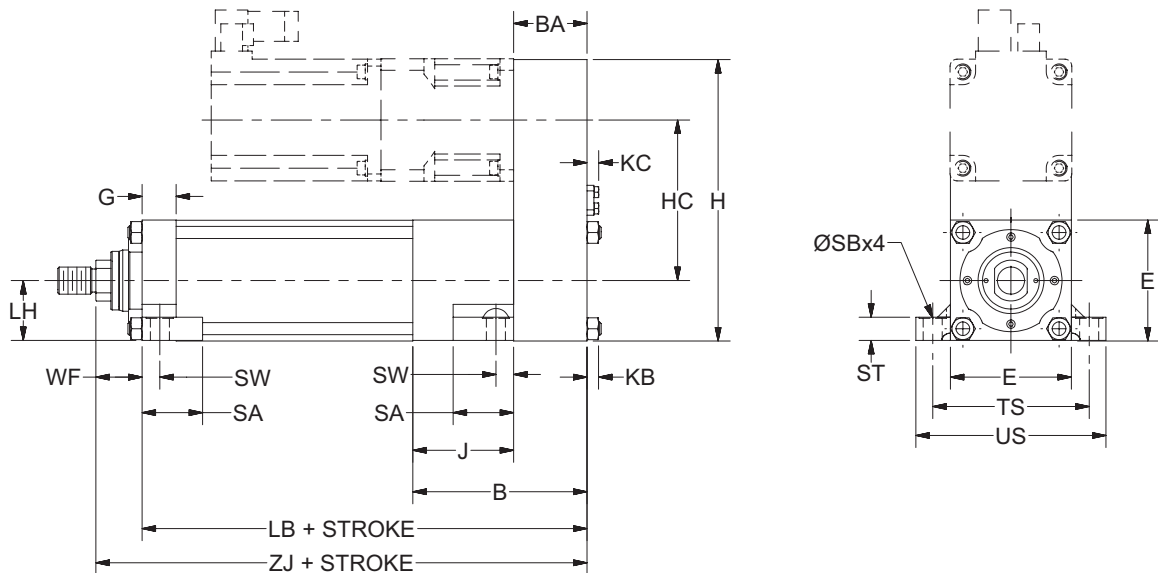

	B	BA	E	G	H	HC	J	KB	KC	LH h10
75	106 (4.17)	44 (1.73)	76.2 (3.00)	22 (0.87)	174.2 (6.86)	98.0 (3.86)	62 (2.44)	6.5 (0.26)	6.93 (0.27)	38 (1.496)
90	128 (5.04)	54 (2.13)	88.9 (3.50)	25 (0.98)	206.9 (8.15)	118.0 (4.65)	74 (2.91)	8.0 (0.31)	8.65 (0.34)	44 (1.732)
115	154 (6.06)	63 (2.48)	114.3 (4.50)	30 (1.18)	271.0 (10.67)	156.0 (6.14)	91 (3.58)	10.0 (0.39)	10.15 (0.40)	57 (2.244)
140	180 (7.09)	72 (2.83)	139.7 (5.50)	35 (1.38)	332.2 (13.08)	192.5 (7.58)	108 (4.25)	13.0 (0.51)	13.65 (0.54)	69 (2.717)
165	211 (8.31)	88 (3.46)	165.1 (6.50)	40 (1.57)	379.1 (14.93)	224.0 (8.82)	123 (4.84)	13.0 (0.51)	13.65 (0.54)	82 (3.228)
190	252 (9.92)	100 (3.94)	190.5 (7.50)	50 (1.97)	455.5 (17.93)	265.0 (10.43)	152 (5.98)	18.0 (0.71)	17.18 (0.68)	95 (3.740)

	SA	ØSB	ST	SW	TS	US	WF	+ STROKE	
								LB	ZJ
75	33.32 (1.31)	11 (0.433)	11.11 (0.44)	11 (0.433)	97 (3.819)	114.30 (4.50)	38 (1.496)	249.5 (9.82)	287.5 (11.32)
90	44.45 (1.75)	14 (0.551)	17.46 (0.69)	13 (0.512)	115 (4.528)	139.70 (5.50)	40 (1.575)	302.0 (11.89)	342.0 (13.46)
115	57.15 (2.25)	18 (0.709)	23.81 (0.94)	15 (0.591)	155 (6.102)	184.15 (7.25)	45 (1.772)	356.0 (14.02)	401.0 (15.79)
140	57.15 (2.25)	18 (0.709)	23.81 (0.94)	18 (0.709)	175 (6.890)	209.55 (8.25)	45 (1.772)	420.0 (16.54)	465.0 (18.31)
165	73.03 (2.88)	22 (0.866)	30.16 (1.19)	20 (0.787)	210 (8.268)	254.00 (10.00)	60 (2.362)	505.0 (19.88)	565.0 (22.24)
190	92.08 (3.63)	26 (1.024)	36.51 (1.44)	25 (0.984)	260 (10.236)	304.80 (12.00)	62 (2.441)	603.0 (23.74)	665.0 (26.18)

Parallel “H” Mount

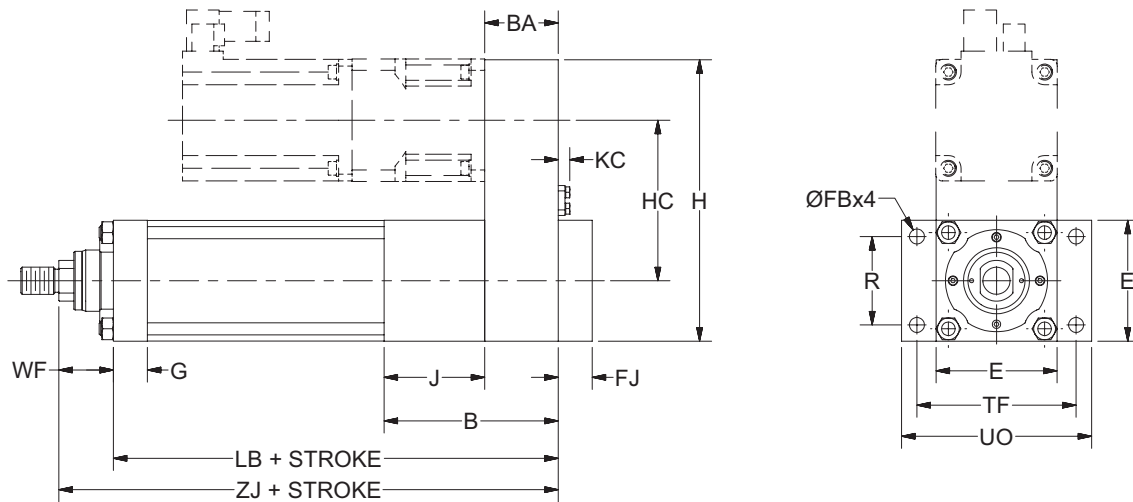

	B	BA	E	ØFB	FJ	G	H	HC
75	106 (4.17)	44 (1.73)	76.2 (3.000)	9 (0.354)	12 (0.472)	22 (0.87)	174.2 (6.86)	98.0 (3.86)
90	128 (5.04)	54 (2.13)	88.9 (3.500)	11 (0.433)	14 (0.551)	25 (0.98)	206.9 (8.15)	118.0 (4.65)
115	154 (6.06)	63 (2.48)	114.3 (4.500)	14 (0.551)	16 (0.630)	30 (1.18)	271.0 (10.67)	156.0 (6.14)
140	180 (7.09)	72 (2.83)	139.7 (5.500)	18 (0.709)	20 (0.787)	35 (1.38)	332.2 (13.08)	192.5 (7.58)
165	211 (8.31)	88 (3.46)	165.1 (6.500)	18 (0.709)	25 (0.984)	40 (1.57)	379.1 (14.93)	224.0 (8.82)
190	252 (9.92)	100 (3.94)	190.5 (7.500)	22 (0.866)	30 (1.181)	50 (1.97)	455.5 (17.93)	265.0 (10.43)

	J	KC	R	TF	UO	WF	+ STROKE	
							LB	ZJ
75	62 (2.44)	6.93 (0.27)	52 (2.047)	105 (4.134)	125.0 (4.921)	38 (1.496)	249.5 (9.82)	287.5 (11.32)
90	74 (2.91)	8.65 (0.34)	65 (2.559)	117 (4.606)	139.7 (5.500)	40 (1.575)	302.0 (11.89)	342.0 (13.46)
115	91 (3.58)	10.15 (0.40)	83 (3.268)	149 (5.866)	175.0 (6.890)	45 (1.772)	356.0 (14.02)	401.0 (15.79)
140	108 (4.25)	13.65 (0.54)	107 (4.213)	172 (6.772)	210.0 (8.268)	45 (1.772)	420.0 (16.54)	465.0 (18.31)
165	123 (4.84)	13.65 (0.54)	126 (4.961)	208 (8.189)	250.0 (9.843)	60 (2.362)	505.0 (19.88)	565.0 (22.24)
190	152 (5.98)	17.18 (0.68)	155 (6.102)	253 (9.961)	300.0 (11.811)	62 (2.441)	603.0 (23.74)	665.0 (26.18)

Parallel “BB” Mount

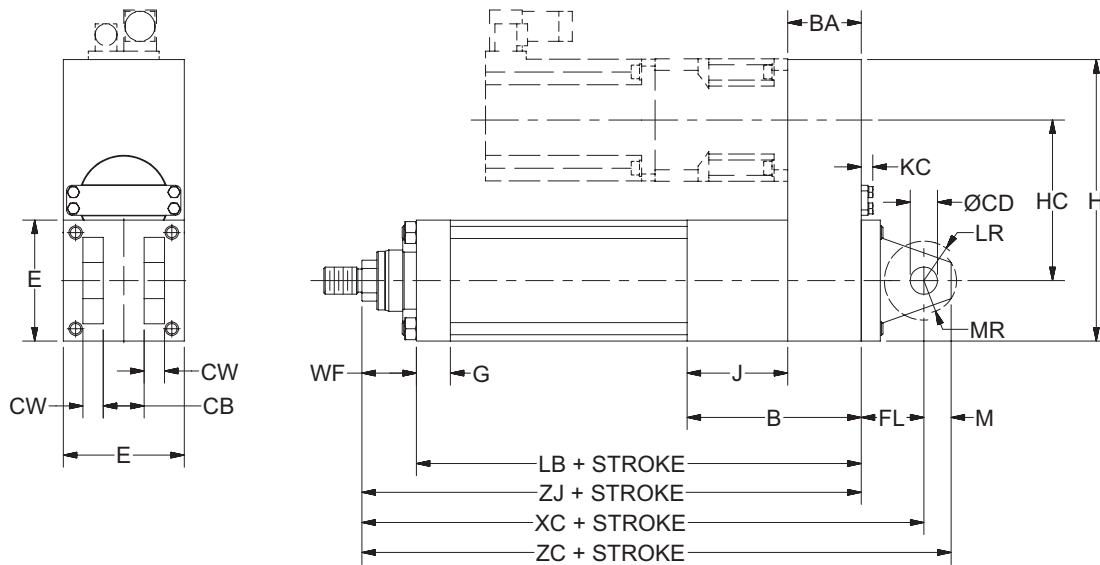

	B	BA	CB A16	ØCD H9	CW	E	FL	G	H	HC
75	106 (4.17)	44 (1.73)	20 (0.79)	14 (0.55)	10 (0.39)	76.2 (3.00)	31 (1.22)	22 (0.87)	174.2 (6.86)	98.0 (3.86)
90	128 (5.04)	54 (2.13)	30 (1.18)	20 (0.79)	15 (0.59)	88.9 (3.50)	46 (1.81)	25 (0.98)	206.9 (8.15)	118.0 (4.65)
115	154 (6.06)	63 (2.48)	30 (1.18)	20 (0.79)	15 (0.59)	114.3 (4.50)	48 (1.89)	30 (1.18)	271.0 (10.67)	156.0 (6.14)
140	180 (7.09)	72 (2.83)	40 (1.57)	28 (1.10)	20 (0.79)	139.7 (5.50)	59 (2.32)	35 (1.38)	332.2 (13.08)	192.5 (7.58)
165	211 (8.31)	88 (3.46)	50 (1.97)	36 (1.42)	25 (0.98)	165.1 (6.50)	79 (3.11)	40 (1.57)	379.1 (14.93)	224.0 (8.82)
190	252 (9.92)	100 (3.94)	60 (2.36)	45 (1.77)	30 (1.18)	190.5 (7.50)	87 (3.43)	50 (1.97)	455.5 (17.93)	265.0 (10.43)

	J	KC	LR	M	MR	WF	+ STROKE			
							LB	XC	ZJ	ZC
75	62 (2.44)	6.93 (0.27)	17 (0.67)	14 (0.55)	16 (0.63)	38 (1.496)	249.5 (9.82)	318.5 (12.54)	287.5 (11.32)	332.5 (13.09)
90	74 (2.91)	8.65 (0.34)	29 (1.14)	20 (0.79)	25 (0.98)	40 (1.575)	302.0 (11.89)	388.0 (15.28)	342.0 (13.46)	408.0 (16.06)
115	91 (3.58)	10.15 (0.40)	29 (1.14)	20 (0.79)	25 (0.98)	45 (1.772)	356.0 (14.02)	449.0 (17.68)	401.0 (15.79)	469.0 (18.46)
140	108 (4.25)	13.65 (0.54)	34 (1.34)	28 (1.10)	34 (1.34)	45 (1.772)	420.0 (16.54)	524.0 (20.63)	465.0 (18.31)	552.0 (21.73)
165	123 (4.84)	13.65 (0.54)	50 (1.97)	36 (1.42)	44 (1.73)	60 (2.362)	505.0 (19.88)	644.0 (25.35)	565.0 (22.24)	680.0 (26.77)
190	152 (5.98)	17.18 (0.68)	53 (2.09)	45 (1.77)	53 (2.09)	62 (2.441)	603.0 (23.74)	752.0 (29.61)	665.0 (26.18)	797.0 (31.38)

Male Rod End

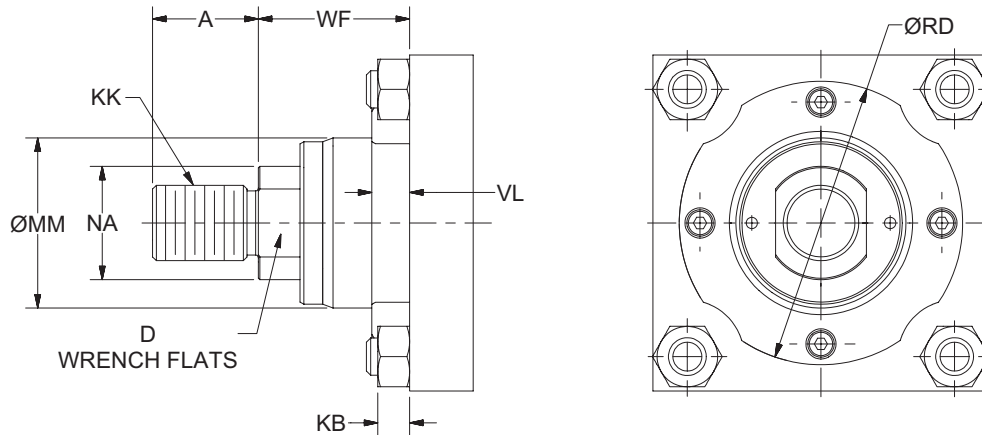

	A	D	KB	KK		ØMM	NA	ØRD f8	VL	WF
				A	B					
75	22 (0.866)	19 (0.75)	6.5 (0.26)	M16x1.5	5/8-18	36 (1.42)	24 (0.94)	65 (2.56)	10 (0.39)	38 (1.496)
90	28 (1.102)	24 (0.94)	8.0 (0.31)	M20x1.5	3/4-16	45 (1.77)	30 (1.18)	75 (2.95)	10 (0.39)	40 (1.575)
115	36 (1.417)	32 (1.26)	10.0 (0.39)	M27x2	1-14	56 (2.20)	40 (1.57)	95 (3.74)	12 (0.47)	45 (1.772)
140	45 (1.772)	39 (1.54)	13.0 (0.51)	M33x2	1 1/4-12	70 (2.76)	49 (1.93)	110 (4.33)	12 (0.47)	45 (1.772)
165	56 (2.205)	48 (1.89)	13.0 (0.51)	M42x2	1 1/2-12	90 (3.54)	60 (2.36)	135 (5.31)	14 (0.55)	60 (2.362)
190	63 (2.480)	55 (2.17)	18.0 (0.71)	M48x2	1 3/4-12	110 (4.33)	70 (2.76)	155 (6.10)	16 (0.63)	62 (2.441)

Rod Eye

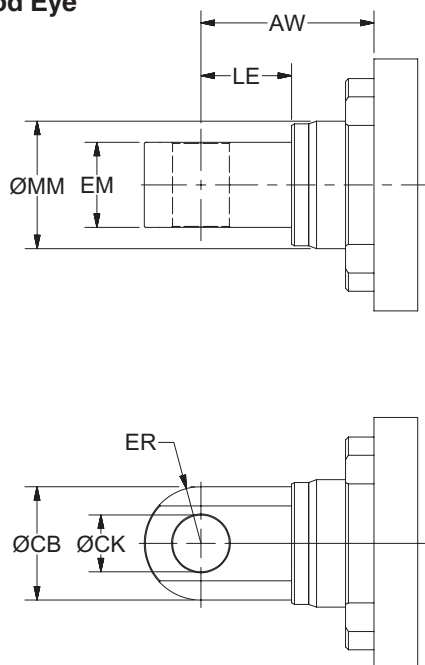

	AW	ØCB	ØCK H9	EM h13	ER MAX	LE	ØMM
75	29 (1.142)	32 (1.260)	14 (0.551)	20 (0.787)	16 (0.63)	19 (0.748)	36 (1.42)
90	29 (1.142)	40 (1.575)	20 (0.787)	30 (1.181)	20 (0.79)	32 (1.260)	45 (1.77)
115	34 (1.339)	45 (1.772)	20 (0.787)	30 (1.181)	23 (0.89)	32 (1.260)	56 (2.20)
140	34 (1.339)	60 (2.362)	28 (1.102)	40 (1.575)	30 (1.18)	39 (1.535)	70 (2.76)
165	45 (1.772)	80 (3.150)	36 (1.417)	50 (1.969)	40 (1.57)	54 (2.126)	90 (3.54)
190	47 (1.850)	100 (3.937)	45 (1.772)	60 (2.362)	50 (1.97)	57 (2.244)	110 (4.33)

Rod Clevis

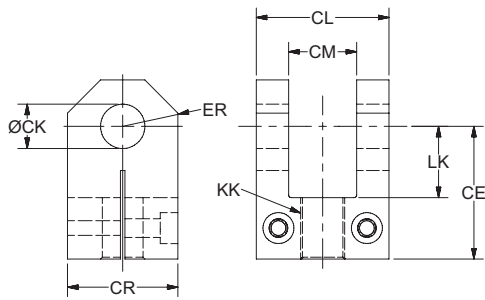

Size Part No.	CE	CL	CM A16	ØCK H9	CR	LK MIN	ER MAX	KK
75 0910440075	41 (1.614)	42.0 (1.654)	20 (0.787)	14 (0.551)	30.0 (1.181)	19.00 (0.748)	15.53 (0.61)	M16x1.5
90 0910440090	60 (2.362)	62.0 (2.441)	30 (1.181)	20 (0.787)	50.0 (1.969)	32.00 (1.260)	25.32 (1.00)	M20x1.5
115 0910440115	68 (2.677)	62.0 (2.441)	30 (1.181)	20 (0.787)	50.0 (1.969)	32.00 (1.260)	25.71 (1.01)	M27x2
140 0910440140	84 (3.307)	83.0 (3.268)	40 (1.575)	28 (1.102)	60.0 (2.362)	39.00 (1.535)	32.50 (1.28)	M33x2
165 0910440165	110 (4.331)	103.0 (4.055)	50 (1.969)	36 (1.417)	76.0 (2.992)	54.00 (2.126)	41.04 (1.62)	M42x2
190 0910440190	120 (4.724)	123.0 (4.843)	60 (2.362)	45 (1.772)	101.5 (3.996)	57.00 (2.244)	51.83 (2.04)	M48x2

Clevis Bracket

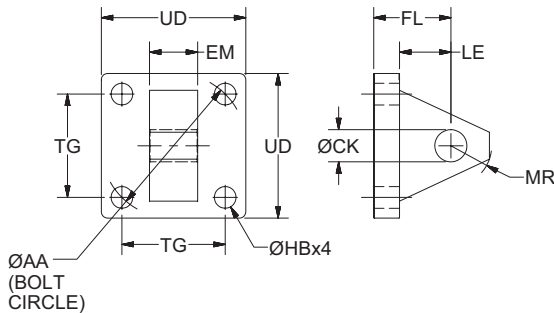

Size Part No.	ØAA	ØCK H9	EM h13	FL	ØHB	LE MIN	MR MAX	TG	UD
75 144810	59 (2.323)	14 (0.551)	20 (0.787)	29 (1.142)	9.0 (0.354)	19 (0.748)	17 (0.67)	41.7 (1.642)	65 (2.56)
90 144811	74 (2.913)	20 (0.787)	30 (1.181)	48 (1.890)	13.5 (0.531)	32 (1.260)	29 (1.14)	52.3 (2.059)	75 (2.95)
115 144812	91 (3.583)	20 (0.787)	30 (1.181)	48 (1.890)	13.5 (0.531)	32 (1.260)	29 (1.14)	64.3 (2.531)	90 (3.54)
140 144813	117 (4.606)	28 (1.102)	40 (1.575)	59 (2.323)	17.5 (0.689)	39 (1.535)	34 (1.34)	82.7 (3.256)	115 (4.53)
165 144814	137 (5.394)	36 (1.417)	50 (1.969)	79 (3.110)	17.5 (0.689)	54 (2.126)	50 (1.97)	96.9 (3.815)	130 (5.12)
190 144815	178 (7.008)	45 (1.772)	60 (2.362)	87 (3.425)	26.0 (1.024)	57 (2.244)	53 (2.09)	125.9 (4.957)	165 (6.50)

Pivot Pin



Size Part No.	ØEK f8	EL
75 143479	14 (0.551)	45 (1.77)
90 143480	20 (0.787)	66 (2.60)
115 143480	20 (0.787)	66 (2.60)
140 143481	28 (1.102)	87 (3.43)
165 143482	36 (1.417)	107 (4.21)
190 143483	45 (1.772)	129 (5.08)

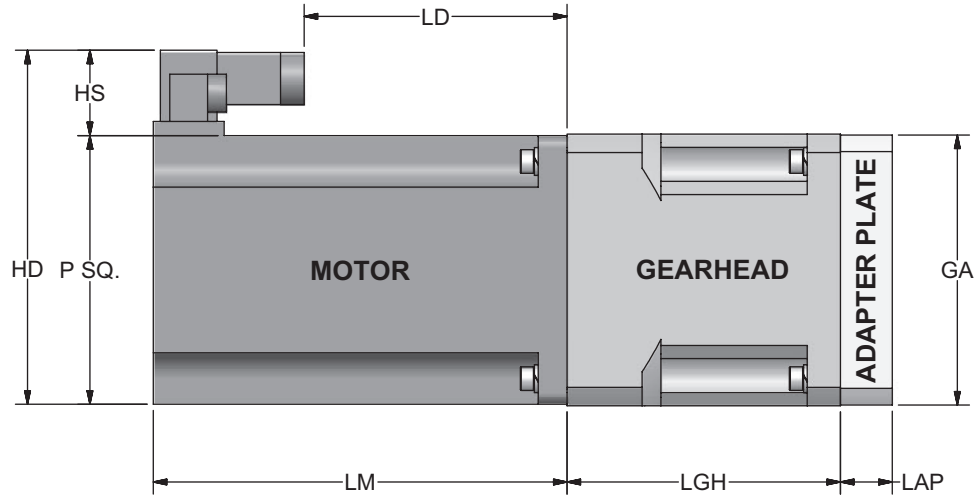

Motor

MPP	HD	HS	LM						LD						P
			MPP ---1	MPP ---2	MPP ---3	MPP ---4	MPP ---6	MPP ---8	MPP ---1	MPP ---2	MPP ---3	MPP ---4	MPP ---6	MPP ---8	
92	136.4 (5.37)	47.6 (1.87)	127.2 (5.01)	152.6 (6.01)	178.0 (7.01)				64.2 (2.53)	90.2 (3.55)	115.2 (4.54)				88.8 (3.50)
100	143.8 (5.66)	46.0 (1.81)		149.1 (5.87)	174.5 (6.87)					86.2 (3.39)	111.2 (4.38)				97.8 (3.85)
115	159.0 (6.26)	46.0 (1.81)		152.4 (6.00)	177.8 (7.00)	203.2 (8.00)				89.2 (3.51)	115.2 (4.54)	140.2 (5.52)			113.0 (4.45)
142	188.8 (7.43)	46.1 (1.81)		172.9 (6.81)		223.7 (8.81)	274.5 (10.81)	325.3 (12.81)		109.9 (4.33)		160.8 (6.33)	211.9 (8.34)	261.9 (10.31)	142.7 (5.62)
190	260.1 (10.24)	75.2 (2.96)				224.0 (8.82)	275.0 (10.83)	325.3 (12.81)				110.3 (4.34)	161.3 (6.35)	211.3 (8.32)	184.9 (7.28)
230	303.4 (11.94)	68.4 (2.69)					284.4 (11.20)	335.2 (13.20)					165.0 (6.50)	216.2 (8.51)	235.0 (9.25)
270	335.9 (13.22)	69.2 (2.72)					293.3 (11.55)	344.1 (13.55)					175.3 (6.90)	255.5 (10.06)	266.7 (10.50)

Adapter Plate

XFC	LAP									
	PARKER STEALTH					MAX PLUS +				
	90	115	142	180	220	115	142	190	230	270
75	19 (0.75)	24 (0.94)				12 (0.47)	16 ¹ (0.63)			
90	0 (0.00)	22 (0.87)				12 (0.47)	16 (0.63)			
115		0 (0.00)	24 (0.94)				16 (0.63)	25 (0.98)		
140			0 (0.00)	24 (0.94)				25 (0.98)	30 (1.18)	
165			0 (0.00)	24 (0.94)					30 (1.18)	30 (1.18)
190				0 (0.00)	36 (1.42)					

Gearhead

	PS	GA	LGH
90		90 (3.54)	97.5 (3.84)
115		115 (4.53)	115.7 (4.56)
142		142 (5.59)	158.5 (6.24)
180		182 (7.17)	147.5 (5.81)
220		220 (8.66)	206.5 (8.13)

¹Available on in-line only.

Standard Features

- Power range of 1kW...75kW
- 8 digital inputs, 4 digital outputs
- RS232 / RS485 – interfaces
- 2 analog inputs (+/-10V, 14 bits)
- 2 analog outputs (+/-10V, 8 bits)
- Encoder input or output
- **Motors supported:**
 - Synchronous servo motors
 - Asynchronous motors
 - Linear motors
 - Torque motors
- **Position sensing at the motor shaft via:**
 - Resolver
 - Rotary/linear encoder
 - Sine-cosine feedback
 - Hiperface interface
 - EnDat 2.1 interface
 - Compatible with most available feedback systems
- Support for SSI feedback

Extensions

- Real-time bus for axis coupling
- Scalable technology and control functions
- Integrated or external controls: C3 powerPLmC for combined machine logic and motion control functionality

Functions (summary)

- Programmable according to IEC61131-3
- Reg-related positioning, electronic gearing, dynamic positioning (motion superimposition) and torque-force control
- Cam – modular, with coupling and decoupling functions, cam switching mechanism

Technologies

- T10: Step/Direction and Analog Command Input
- T11: Positioning indexer
- T30: IEC61131-3 Positioning with function modules according to PLCopen
- T40: IEC61131-3 Positioning with Cam function modules

Compax3 Power Range

Compax3 device	Current A _{RMS}		Supply voltage
	I _{cont}	I _{peak} (<5s)	
S025V2	2.5	5.5	1 ¹ 230/240VAC
S063V2	6.3	12.6	
S100V2	10	20	3 ¹ 230/240VAC
S150V2	15	30	
S038V4 ¹	3.8	9.0	3 ¹ 400/480VAC
S075V4 ¹	7.5	15	
S150V4 ¹	15	30	
S300V4 ¹	30	60	3 ¹ 400/480VAC
H050V4 ¹	50	75	
H090V4 ¹	90	135	
H125V4 ¹	125	187.5	
H155V4 ¹	155	232.5	

¹Rated at 400VAC

powerPLmC Machine Controller

C3 Power PLmC – C10²
– Integrated –
into the servo drive



C3 powerPLmC - E20
– standalone –
without servo drive

- 32-bit RISC processor: <100 μs for 1000 lcommands
- Programmable based on IEC61131-3 /PLCopen
- Simple integration of the servo axes due to Parker's Drive Interface
- Integrated motion control functions for dynamic, coordinated control of 32+ axes
- CoDeSys professional development tool
- Full machine logic capabilities
- Additional system components offered by Parker:

Parker offers HMI solutions for any application from simple push button replacement through sophisticated networking, multimedia and data logging requirements. Products range from entry level embedded displays through full Windows based Industrial PC solutions.



PIO: Parker digital and analog inputs / outputs – modular extensions



Parker offers a broad family of motors with unparalleled performance, a torque range of 1.2 in-lbs to 4000 in-lbs and complete customization capabilities. For higher torque requirements, Parker's Stealth gearheads are the perfect solution.

²Available as a custom product

Ordering a Compax3 System

Table A – Compax3 Order Code

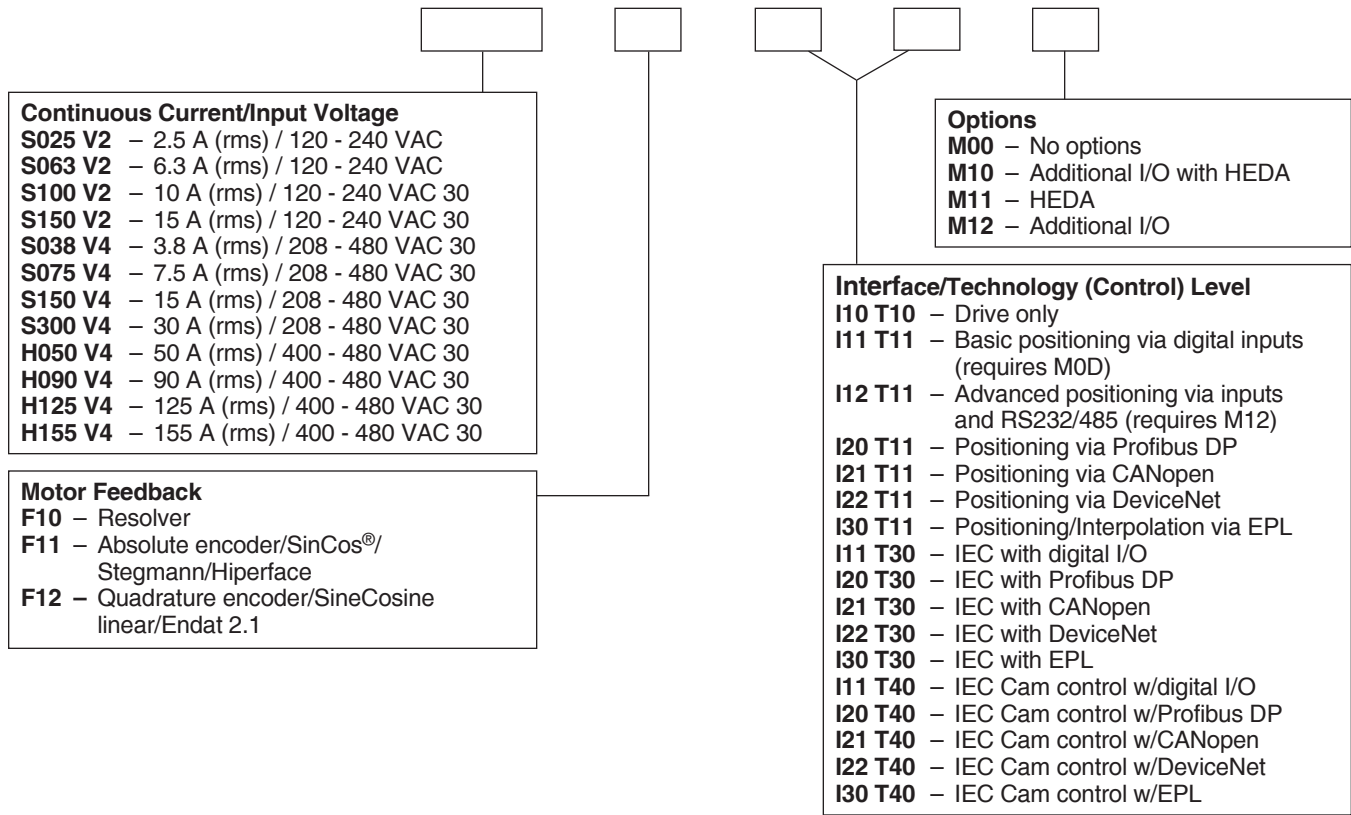

Table B – Servo Motor Power/Feedback Cables – As Easy as 1-2-3-!

Compax3 PS Motor-Drive Cables

PS Feedback Cables			PS Motor Power Cables		
1. Choose your Feedback Type	2. Choose your Motor Family	3. Your Part Number is:	1. Choose your Motor Current	2. Choose your Motor Family	3. Your Part Number is:
Resolver	<ul style="list-style-type: none"> BE 23, 24 NeoMetric/ J Series 34, 70, 92 MaxPlus 72-190 M Series 105 - 205 SMN 60-142 MaxPlusPlus (MPP) 	F-2B1-xx	Up to 6A RMS continuous (240VAC only)	<ul style="list-style-type: none"> BE 23 NeoMetric, J Series MaxPlusPlus (MPP) 	P-1A1-xx
SinCos/ Stegmann/ Hiperface	<ul style="list-style-type: none"> BE 34 NeoMetric/ J Series 34, 70, 92 MaxPlus 72-190 M Series 105-205 SMN 60-142 MaxPlusPlus (MPP) 	F-2B1-xx	Up to 20A RMS continuous (240 or 480V)	<ul style="list-style-type: none"> BE 34 NeoMetric, J Series MaxPlus M Series SMN Series MaxPlusPlus (MPP) 	P-3B1-xx
Encoder/ Endat 2.1	<ul style="list-style-type: none"> BE 23, 34 NeoMetric/ J Series 34, 70, 92 MaxPlus 72-190 M Series 105-205 SMN 60-142 MaxPlusPlus (MPP) 	F-2C1-xx	20A to 30A RMS (240 or 480V)	<ul style="list-style-type: none"> M Series MaxPlusPlus (MPP) 	P-4B1-xx
			20A to 30A RMS (240 or 480V)	<ul style="list-style-type: none"> M Series MaxPlus MaxPlusPlus (MPP) 	P-4B2-xx
			30A to 50A RMS (240 or 480V)	<ul style="list-style-type: none"> M Series MaxPlus MaxPlusPlus (MPP) 	P-6B2-xx
			> 50A RMS	Contact factory	Custom Product

-xx denotes cable length in feet; motor power and feedback cables available in standard lengths of 10, 25 and 50 feet (other lengths also available).

Safety Guide for Selecting and Using Electromechanical Cylinders and Their Accessories

WARNING: ⚠ **FAILURE OF THE CYLINDER, ITS PARTS, ITS MOUNTING, AND ITS CONNECTIONS TO OTHER OBJECTS OR ITS CONTROLS CAN RESULT IN:**

- Unanticipated or uncontrolled movement of the cylinder or objects connected to it.
- Falling of the cylinder or objects held up by it.

These events could cause death or personal injury by, for example, persons falling from high locations, being crushed or struck by heavy or fast moving objects, being pushed into dangerous equipment or situations.

Before selecting or using Parker (the Company) cylinders or related accessories, it is important that you read, understand and follow the following safety information. Training is advised before selecting and using the Company's products.

1.0 General Instructions

1.1 Scope – This safety guide provides instructions for selecting and using (including assembling, installing, and maintaining) cylinder products. This safety guide is a supplement to and is to be used with the specific Company publications for the specific cylinder products that are being considered for use.

1.2 Fail Safe – Cylinder products can and do fail without warning for many reasons. All systems and equipment should be designed in a fail-safe mode so that if the failure of a cylinder product occurs people and property won't be endangered.

1.3 Distribution – Provide a free copy of this safety guide to each person responsible for selecting or using cylinder products. Do not select or use the Company's cylinders without thoroughly reading and understanding this safety guide as well as the specific Company publications for the products considered or selected.

1.4 User Responsibility – Due to very wide variety of cylinder applications and cylinder operating conditions, the Company does not warrant that any particular cylinder is suitable for any specific application. This safety guide does not analyze all technical parameters that must be considered in selecting a product. The electromechanical cylinders outlined in this catalog are designed to the Company's design guidelines and do not necessarily meet the design guideline of other agencies such as American Bureau of Shipping.

The user, through its own analysis and testing, is solely responsible for:

- Making the final selection of the cylinders and related accessories.
- Determining if the cylinders are required to meet specific design requirements as required by the Agency(s) or industry standards covering the design of the user's equipment.
- Assuring that the user's requirements are met, OSHA requirements are met, and safety guidelines from the applicable agencies such as but not limited to ANSI are followed and that the use presents no health or safety hazards.
- Providing all appropriate health and safety warnings on the equipment on which the cylinders are used.

1.5 Additional Questions – Call the appropriate Company technical service department if you have any questions or require any additional information. See the Company publication for the product being considered or used, or call 1-847-298-2400, or go to www.parker.com, for telephone numbers of the appropriate technical service department.

2.0 Cylinder and Accessories Selection

2.1 Piston Rods – Possible consequences of piston rod failure or separation of the piston rod from the piston include, but are not limited to:

- Piston rod and or attached load thrown off at high speed.

Piston rods or machine members attached to the piston rod may move suddenly and without warning as a consequence of other conditions occurring to the machine such as, but not limited to:

- Unexpected detachment of the machine member from the piston rod.
- Failure of the machine control system.

Piston rods are not normally designed to absorb bending moments or loads which are perpendicular to the axis of piston rod motion. These additional loads can cause the piston rod to fail. If these types of additional loads are expected to be imposed on the piston rod, their magnitude should be made known to our engineering department.

The cylinder user should always make sure that the piston rod is securely attached to the machine member.

2.2 Cylinder Mountings – Always mount cylinders using the largest possible high tensile alloy steel socket head cap screws that can fit in the cylinder mounting holes and torque them to the manufacturer's recommendations for their size.

3.0 Cylinder and Accessories Installation and Mounting

3.1 Installation

3.1.1 – Cleanliness is an important consideration, and cylinders are shipped with the ports plugged to protect them from contaminants entering the ports. These plugs should not be removed until the piping is to be installed. Before making the connection to the cylinder ports, piping should be thoroughly cleaned to remove all chips or burrs which might have resulted from threading or flaring operations.

3.1.2 – Cylinders operating in an environment where air drying materials are present such as fast-drying chemicals, paint, or weld splatter, or other hazardous conditions such as excessive heat, should have shields installed to prevent damage to the piston rod and piston rod seals.

3.1.3 – Proper alignment of the cylinder piston rod and its mating component on the machine should be checked in both the extended and retracted positions. Improper alignment will result in excessive rod gland and/or cylinder bore wear. On fixed mounting cylinders attaching the piston rod while the rod is retracted will help in achieving proper alignment.

3.2 Mounting Recommendations

3.2.1 – Always mount cylinders using the largest possible high tensile alloy steel socket head screws that can fit in the cylinder mounting holes and torque them to the manufacturer's recommendations for their size.

3.2.2 – Tie Rod Mounting – Cylinders with tie rod mountings are recommended for applications where mounting space is limited. The standard tie rod extension is shown as BB in dimension tables. Longer or shorter extensions can be supplied. Nuts used for this mounting style should be torqued to the same value as the tie rods for that bore size.

3.2.3 – Flange Mount Cylinders – The controlled diameter of the rod seal retainer on head end flange mount cylinders can be used as a pilot to locate the cylinders in relation to the machine

3.2.4 – Trunnion Mountings – Cylinders require lubricated bearing blocks with minimum bearing clearances. Bearing blocks should be carefully aligned and rigidly mounted so the trunnions will not be subjected to bending moments. The rod end should also be pivoted with the pivot pin in line and parallel to axis of the trunnion pins.

3.2.5 – Clevis Mountings – Cylinders should be pivoted at both ends with centerline of pins parallel to each other. After cylinder is mounted, be sure to check to assure that the cylinder is free to swing through its working arc without interference from other machine parts.

4.0 Cylinder and Accessories Maintenance, Troubleshooting and Replacement

4.1 Storage – At times cylinders are delivered before a customer is ready to install them and must be stored for a period of time. When storage is required the following procedures are recommended.

4.1.1 – Store the cylinders in an indoor area which has a dry, clean and non-corrosive atmosphere. Take care to protect the cylinder from both internal corrosion and external damage.

4.1.2 – Whenever possible cylinders should be stored in a vertical position (piston rod up). This will minimize corrosion due to possible condensation which could occur inside the cylinder. This will also minimize seal damage.

4.1.3 – Port protector plugs should be left in the cylinder until the time of installation.

4.1.4 – When cylinders are mounted on equipment that is stored outside for extended periods, exposed unpainted surfaces, e.g. piston rod, must be coated with a rust-inhibiting compound to prevent corrosion.

4.2 Cylinder Trouble Shooting

4.2.1 – External Leakage

4.2.1.1 – Rod seal leakage can generally be traced to worn or damaged seals. Examine the piston rod for dents, gouges or score marks, and replace piston rod if surface is rough.

Rod seal leakage can also be traced to seal deterioration. If seals are soft or gummy or brittle, check compatibility of seal material with lubricant used. If the seals are hard or have lost elasticity, it is usually due to exposure to temperatures in excess of 165°F. (+74°C). Shield the cylinder from the heat source to limit temperature to 350°F. (+177°C.) and replace with fluorocarbon seals.

4.2.1.2 – Cylinder body seal leak can generally be traced to loose tie rods. Torque the tie rods to manufacturer's recommendation for that frame size.

Pinched or extruded cylinder body seal will also result in a leak. Replace cylinder body seal and retorqued as in paragraph above.

4.2.2 – Cylinder Fails to Move the Load

4.2.2.1 – Cylinder is undersized for the load – Replace cylinder with one of a larger bore size.

4.3 Erratic Operation

4.3.1 – Excessive friction at rod gland or piston bearing due to load misalignment – Correct cylinder-to-load alignment.

4.3.2 – Cylinder sized too close to load requirements – Reduce load or install larger cylinder.

4.3.3 – Erratic operation could be traced to the difference between static and kinetic friction

4.4 Cylinder Modifications, Repairs, or Failed Component

– Cylinders as shipped from the factory are not to be disassembled and or modified. If cylinders require modifications, these modifications must be done at company locations or by the Company's certified facilities. The Cylinder Division Engineering Department must be notified in the event of a mechanical fracture or permanent deformation of any cylinder component (excluding seals). This includes a broken piston rod, tie rod, mounting accessory or any other cylinder component. The notification should include all operation and application details. This information will be used to provide an engineered repair that will prevent recurrence of the failure.

4.5 Electrical Components – For safety and storage information of Controller, Drives, Motors, and Gearheads please contact Parker Hannifin Electromechanical N.A.

Offer of Sale

The items described in this document and other documents and descriptions provided by Parker Hannifin Corporation, Hydraulics Group, and its authorized distributors ("Seller") are hereby offered for sale at prices to be established by Seller. This offer and its acceptance by any customer ("Buyer") shall be governed by all of the following Terms and Conditions. Buyer's order for any item described in its document, when communicated to Seller verbally, or in writing, shall constitute acceptance of this offer. All goods or work described will be referred to as "Products".

1. Terms and Conditions. Seller's willingness to offer Products, or accept an order for Products, to or from Buyer is expressly conditioned on Buyer's assent to these Terms and Conditions and to the terms and conditions found on-line at www.parker.com/saleterms/. Seller objects to any contrary or additional term or condition of Buyer's order or any other document issued by Buyer.

2. Price Adjustments; Payments. Prices stated on the reverse side or preceding pages of this document are valid for 30 days. After 30 days, Seller may change prices to reflect any increase in its costs resulting from state, federal or local legislation, price increases from its suppliers, or any change in the rate, charge, or classification of any carrier. The prices stated on the reverse or preceding pages of this document do not include any sales, use, or other taxes unless so stated specifically. Unless otherwise specified by Seller, all prices are F.O.B. Seller's facility, and payment is due 30 days from the date of invoice. After 30 days, Buyer shall pay interest on any unpaid invoices at the rate of 1.5% per month or the maximum allowable rate under applicable law.

3. Delivery Dates; Title and Risk; Shipment. All delivery dates are approximate and Seller shall not be responsible for any damages resulting from any delay. Regardless of the manner of shipment, title to any products and risk of loss or damage shall pass to Buyer upon tender to the carrier at Seller's facility (i.e., when it's on the truck, it's yours). Unless otherwise stated, Seller may exercise its judgment in choosing the carrier and means of delivery. No deferment of shipment at Buyers' request beyond the respective dates indicated will be made except on terms that will indemnify, defend and hold Seller harmless against all loss and additional expense. Buyer shall be responsible for any additional shipping charges incurred by Seller due to Buyer's changes in shipping, product specifications or in accordance with Section 13, herein.

4. Warranty. Seller warrants that the Products sold hereunder shall be free from defects in material or workmanship for a period of eighteen months from the date of delivery to Buyer. The prices charged for Seller's products are based upon the exclusive limited warranty stated above, and upon the following disclaimer: **DISCLAIMER OF WARRANTY: THIS WARRANTY COMPRISES THE SOLE AND ENTIRE WARRANTY PERTAINING TO PRODUCTS PROVIDED HEREUNDER. SELLER DISCLAIMS ALL OTHER WARRANTIES, EXPRESS AND IMPLIED, INCLUDING MERCHANTABILITY AND FITNESS FOR A PARTICULAR PURPOSE.**

5. Claims; Commencement of Actions. Buyer shall promptly inspect all Products upon delivery. No claims for shortages will be allowed unless reported to the Seller within 10 days of delivery. No other claims against Seller will be allowed unless asserted in writing within 60 days after delivery or, in the case of an alleged breach of warranty, within 30 days after the date within the warranty period on which the defect is or should have been discovered by Buyer. Any action based upon breach of this agreement or upon any other claim arising out of this sale (other than an action by Seller for any amount due to Seller from Buyer) must be commenced within thirteen months from the date of tender of delivery by Seller or, for a cause of action based upon an alleged breach of warranty, within thirteen months from the date within the warranty period on which the defect is or should have been discovered by Buyer.

6. LIMITATION OF LIABILITY. UPON NOTIFICATION, SELLER WILL, AT ITS OPTION, REPAIR OR REPLACE A DEFECTIVE PRODUCT, OR REFUND THE PURCHASE PRICE. IN NO EVENT SHALL SELLER BE LIABLE TO BUYER FOR ANY SPECIAL, INDIRECT, INCIDENTAL OR CONSEQUENTIAL DAMAGES ARISING OUT OF, OR AS THE RESULT OF, THE SALE, DELIVERY, NON-DELIVERY, SERVICING, USE OR LOSS OF USE OF THE PRODUCTS OR ANY PART THEREOF, OR FOR ANY CHARGES OR EXPENSES OF ANY NATURE INCURRED WITHOUT SELLER'S WRITTEN CONSENT, EVEN IF SELLER HAS BEEN NEGLIGENT, WHETHER IN CONTRACT, TORT OR OTHER LEGAL THEORY. IN NO EVENT SHALL SELLER'S LIABILITY UNDER ANY CLAIM MADE BY BUYER EXCEED THE PURCHASE PRICE OF THE PRODUCTS.

7. Contingencies. Seller shall not be liable for any default or delay in performance if caused by circumstances beyond the reasonable control of Seller.

8. User Responsibility. The user, through its own analysis and testing, is solely responsible for making the final selection of the system and Product and assuring that all performance, endurance, maintenance, safety and warning requirements of the application are met. The user must analyze all aspects of the application and follow applicable industry standards and Product information. If Seller provides Product or system options, the user is responsible for determining that such data and specifications are suitable and sufficient for all applications and reasonably foreseeable uses of the Products or systems.

9. Loss to Buyer's Property. Any designs, tools, patterns, materials, drawings, confidential information or equipment furnished by Buyer or any other items which become Buyer's property, may be considered obsolete and may be destroyed by Seller after two consecutive years have elapsed without Buyer placing an order for the items which are manufactured using such property. Seller shall not be responsible for any loss or damage to such property while it is in Seller's possession or control.

10. Special Tooling. A tooling charge may be imposed for any special tooling, including without limitation, dies, fixtures, molds and patterns, acquired to manufacture Products. Such special tooling shall be and remain Seller's property notwithstanding payment of any charges by Buyer. In no event will Buyer acquire any interest in apparatus belonging to Seller which is utilized in the manufacture of the Products, even if such apparatus has been specially converted or adapted for such manufacture and notwithstanding any charges paid by Buyer. Unless otherwise agreed, Seller shall have the right to alter, discard or otherwise dispose of any special tooling or other property in its sole discretion at any time.

11. Buyer's Obligation; Rights of Seller. To secure payment of all sums due or otherwise, Seller shall retain a security interest in the goods delivered and this agreement shall be deemed a Security Agreement under the Uniform Commercial Code. Buyer authorizes Seller as its attorney to execute and file on Buyer's behalf all documents Seller deems necessary to perfect its security interest. Seller shall have a security interest in, and lien upon, any property of Buyer in Seller's possession as security for the payment of any amounts owed to Seller by Buyer.

12. Improper Use and Indemnity. Buyer shall indemnify, defend, and hold Seller harmless from any claim, liability, damages, lawsuits, and costs (including attorney fees), whether for personal injury, property damage, patent, trademark or copyright infringement or any other claim, brought by or incurred by Buyer, Buyer's employees, or any other person, arising out of: (a) improper selection, improper application or other misuse of Products purchased by Buyer from Seller; (b) any act or omission, negligent or otherwise, of Buyer; (c) Seller's use of patterns, plans, drawings, or specifications furnished by Buyer to manufacture Product; or (d) Buyer's failure to comply with these terms and conditions. Seller shall not indemnify Buyer under any circumstance except as otherwise provided.

13. Cancellations and Changes. Orders shall not be subject to cancellation or change by Buyer for any reason, except with Seller's written consent and upon terms that will indemnify, defend and hold Seller harmless against all direct, incidental and consequential loss or damage. Seller may change product features, specifications, designs and availability with notice to Buyer.

14. Limitation on Assignment. Buyer may not assign its rights or obligations under this agreement without the prior written consent of Seller.

15. Entire Agreement. This agreement contains the entire agreement between the Buyer and Seller and constitutes the final, complete and exclusive expression of the terms of the agreement. All prior or contemporaneous written or oral agreements or negotiations with respect to the subject matter are herein merged.

16. Waiver and Severability. Failure to enforce any provision of this agreement will not waive that provision nor will any such failure prejudice Seller's right to enforce that provision in the future. Invalidation of any provision of this agreement by legislation or other rule of law shall not invalidate any other provision herein. The remaining provisions of this agreement will remain in full force and effect.

17. Termination. This agreement may be terminated by Seller for any reason and at any time by giving Buyer thirty (30) days written notice of termination. In addition, Seller may by written notice immediately terminate this agreement for the following: (a) Buyer commits a breach of any provision of this agreement (b) the appointment of a trustee, receiver or custodian for all or any part of Buyer's property (c) the filing of a petition for relief in bankruptcy of the other Party on its own behalf, or by a third party (d) an assignment for the benefit of creditors, or (e) the dissolution or liquidation of the Buyer.

18. Governing Law. This agreement and the sale and delivery of all Products hereunder shall be deemed to have taken place in and shall be governed and construed in accordance with the laws of the State of Ohio, as applicable to contracts executed and wholly performed therein and without regard to conflicts of laws principles. Buyer irrevocably agrees and consents to the exclusive jurisdiction and venue of the courts of Cuyahoga County, Ohio with respect to any dispute, controversy or claim arising out of or relating to this agreement. Disputes between the parties shall not be settled by arbitration unless, after a dispute has arisen, both parties expressly agree in writing to arbitrate the dispute.

19. Indemnity for Infringement of Intellectual Property Rights. Seller shall have no liability for infringement of any patents, trademarks, copyrights, trade dress, trade secrets or similar rights except as provided in this Section. Seller will defend and indemnify Buyer against allegations of infringement of U.S. patents, U.S. trademarks, copyrights, trade dress and trade secrets ("Intellectual Property Rights"). Seller will defend at its expense and will pay the cost of any settlement or damages awarded in an action brought against Buyer based on an allegation that a Product sold pursuant to this Agreement infringes the Intellectual Property Rights of a third party. Seller's obligation to defend and indemnify Buyer is contingent on Buyer notifying Seller within ten (10) days after Buyer becomes aware of such allegations of infringement, and Seller having sole control over the defense of any allegations or actions including all negotiations for settlement or compromise. If a Product is subject to a claim that it infringes the Intellectual Property Rights of a third party, Seller may, at its sole expense and option, procure for Buyer the right to continue using the Product, replace or modify the Product so as to make it noninfringing, or offer to accept return of the Product and return the purchase price less a reasonable allowance for depreciation. Notwithstanding the foregoing, Seller shall have no liability for claims of infringement based on information provided by Buyer, or directed to Products delivered hereunder for which the designs are specified in whole or part by Buyer, or infringements resulting from the modification, combination or use in a system of any Product sold hereunder. The foregoing provisions of this Section shall constitute Seller's sole and exclusive liability and Buyer's sole and exclusive remedy for infringement of Intellectual Property Rights.

20. Taxes. Unless otherwise indicated, all prices and charges are exclusive of excise, sales, use, property, occupational or like taxes which may be imposed by any taxing authority upon the manufacture, sale or delivery of Products.

21. Equal Opportunity Clause. For the performance of government contracts and where dollar value of the Products exceed \$10,000, the equal employment opportunity clauses in Executive Order 11246, VEVRAA, and 41 C.F.R. §§ 60-1.4(a), 60-741.5(a), and 60-250.4, are hereby incorporated.







Parker Hannifin Corporation
500 South Wolf Road
Des Plaines, IL 60016 USA
phone (847) 298-2400
fax (800) 892-1008
www.parker.com/cylinder

Your Local Authorized Parker Distributor