

Ball Bearing Positioners

miniature and standard

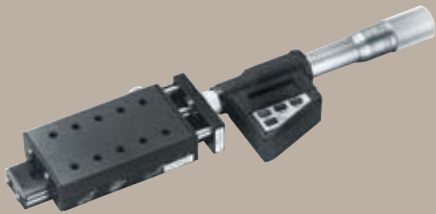
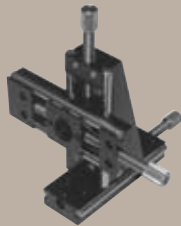

Parker Daedal precision linear stages provide controlled, precise point-to-point positioning along a linear axis. Stages are comprised of two basic components: a precision linear ball slide which serves as a linear bearing and guide, and a drive mechanism which accurately moves and positions the slide top along the linear axis.

Contents

62-63	Overview
64-67	1.25" (31,8 mm) Wide or Less
68-73	1.75" (44,5 mm) Wide
74-79	2.62" (66,5 mm) Wide
80-83	5.00" (127,0 mm) Wide
84-86	6.00" (152,4 mm) Wide
87-88	Performance Curves

Miniature and Standard Size Ball Bearings Positioners



- Precision Quality
- Budget Friendly
- Largest Selection
- Easy multi-axis configuration
- No maintenance
- Vacuum preparation and custom options

Ball Bearing Positioner Design Principles

Parker Daedal precision linear stages provide controlled, precise point-to-point positioning along a linear axis. Stages are comprised of two basic components: a precision linear ball slide which serves as a linear bearing and guide, and a drive mechanism which accurately moves and positions the slide top along the linear axis.

Three types of drive mechanisms are available: a fine screw, a micrometer, and a differential screw. The fine screw is used for fine resolution positioning. The micrometer is used whenever a position readout is required. The differential screw is used for applications requiring extremely fine resolution positioning. Ball bearing positioning stages are available in a straight stage/drive configuration as well as a side-drive configuration.

The linear positioner operates in a simple manner: a bracket which supports the drive screw is attached to the slide base. The end of the drive screw rests against the end of the moveable top. There are two extended springs “pulling” the slide top toward the screw so that the top will always be held firmly against the screw end. When the screw is turned clockwise, it advances and pushes the slide top along the linear axis. When turned counter clockwise, the screw retracts and the slide top follows because of the spring pressure holding the top against the screw end. The result is a very smooth linear motion, accurately controlled by rotation of the drive mechanism.

Standard Features

Exact manufacturing techniques, combined with demanding quality control standards, permit Parker Daedal to offer precision stages of unsurpassed quality. Selection can be made easily, based on required travel, load, and mounting surface requirements. Stages are available in single or multi-axis configurations (XY, XZ, and XYZ), and all have built-in quality features including:

- Aluminum top and base and stainless steel bearings
- Low friction linear adjustment with no backlash or side play
- Factory preloaded to provide dynamic stability and minimum runout
- Both top and bottom mounting surfaces are precision machined to provide flat mounting surfaces
- Locking screw to positively lock stage without affecting position (standard on most models)
- Straight line accuracy of 0.00008 in/in of travel
- Selectable drive mechanisms: Micrometer (Imperial or metric), Fine screw (64 pitch), Differential screw, Digital micrometers (Imperial and Metric)

Digital Micrometers

The 1.0” (25 mm) travel micrometer provides an LCD readout to 0.00005 in (0,001 mm) resolution and features incremental and/or absolute positioning modes and automatic shutdown to conserve the integral battery. The battery will power the unit for 500 hours of use. The 2.0” (51 mm) micrometer is accurate to ± 0.0001 in (± 2 microns) with a resolution and LCD reading to 0.00005 in (1 micron). The batteries will power the unit up to 500 hours.

How to Order

Use the overview chart on the following page to select the appropriate ball bearing positioner. Refer to the individual specifications page for complete performance and mechanical specifications. To order ball bearing positioners, use the model number corresponding to the specific size and travel length selected. A variety of modifications to standard models are available to meet custom requirements. Contact our application engineering department with your design specifications.

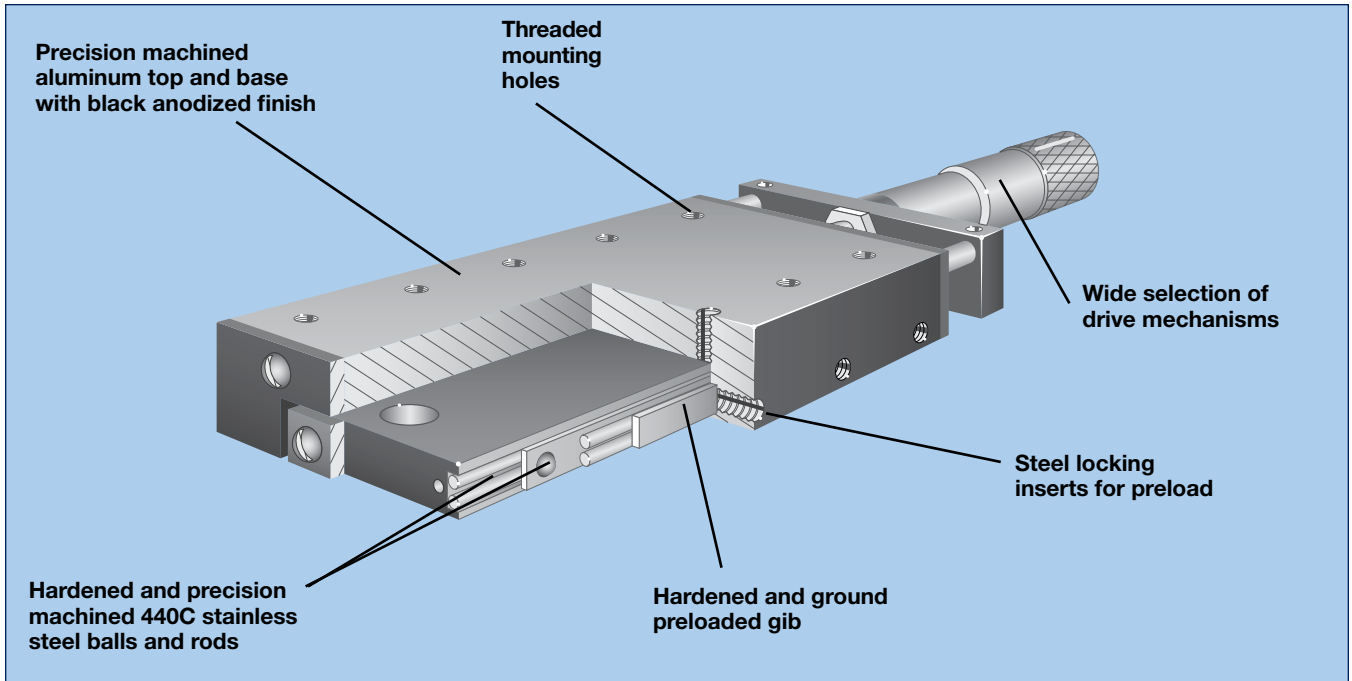

Ball Bearing Positioners

Selection

Series	Width in (mm)	Travel		Normal Load		Drive Orientation		Mounting		Page
		in	(mm)	lbs	(kg)	Center	Side	Imperial	Metric	
MM-1	≤1.25 (≤31,8)	0.125	(3,2)	0.5	(0,25)	•		•		64-65
MM-3		0.50	(12,7)	0.75	(0,34)	•		•		64-65
3900					6	(2,7)	•	•	•	•
4000	1.75 (44,5)	0.50 or 1.00	(12,7 or 25,4)	25	(11)	•	•	•	•	68-69,72
4100				30	(13)	•		•	•	70-71, 73
4200				42	(19)	•		•	•	70-71, 73
4300				55	(25)	•		•	•	70-71, 73
4500	2.62 (66,5)	1.00	(25,4)	62	(28)	•	•	•	•	74-75, 78
4600				88	(40)	•		•	•	76-77, 79
4700				106	(48)	•		•	•	76-77, 79
4800				123	(56)	•		•	•	76-77, 79
4400	5.0 (127,0)	1.0	(25,4)	105	(48)	•	•	•	•	80-83
		2.0	(50,8)	105	(48)	•	•	•	•	80-83
4900	6.0 (152,4)	1.0	(25,4)	100	(45)	•		•	•	84-85
		2.0	(50,8)	100	(45)	•		•	•	84-85
		4.0	(100,0)	100	(45)	•		•	•	86
		6.0	(150,0)	154	(70)	•		•	•	86
		8.0	(200,0)	205	(93)	•		•	•	86
		10.0	(250,0)	243	(110)	•		•	•	86
		12.0	(300,0)	294	(133)	•		•	•	86

3900/M3900 Series

Specifications	Imperial	Metric
Travel:	0.5 in	13 mm
Size:		
Width	1.25 in	31,8 mm
Length (mid-travel)	3.34 in	84,8 mm
Height	0.50 in	12,7 mm
Load:		
Normal	6 lbs	3 kg
Thrust – T _a	10 lbs	4,5 kg
Thrust – T _b	3 lbs	1,4 kg
Moment – Yaw, Pitch, Roll	See page 88	See page 88
Straight line accuracy:	0.00008 in/in of travel	2 µm/25 mm of travel
Micrometer graduations:	0.001 in	0,01 mm
Fine screw:	64 pitch	64 pitch
Weight:	0.16 lbs/axis	0,078 kg/axis
Z-Axis bracket options: (See page 124-127)		
Center drive low profile	3909	M3909
Center drive standard	3910	M3910
Side drive low profile	3959	M3959
Side drive standard	3960	M3960
Construction:	Aluminum top and base/ 440C stainless steel bearings	
Mounting surface:	Precision machined	
Finish:	Black anodize	



	Style	Drive Mechanism	Travel	Center Drive Models				Side Drive Models			
				Single Axis	Two Axis	Y-Y-Z Low Profile	Y-Y-Z Standard	Single Axis	Two Axis	Y-Y-Z Low Profile	Y-Y-Z Standard
Imperial	Solid Top	Imperial Micrometer	0.50 in	3902	3922	3932	3942	3952	3972	3982	3992
		Metric Micrometer	13 mm	3902M	3922M	3932M	3942M	3952M	3972M	3982M	3992M
		Fine Screw	0.50 in	3903	3923	3933	3943	–	–	–	–
	Aperture (0.5 in)	Imperial Micrometer	0.50 in	3906	3926	3936	3946	3956	3976	3986	3996
		Metric Micrometer	13 mm	3906M	3926M	3936M	3946M	3956M	3976M	3986M	3996M
		Fine Screw	0.50 in	3907	3927	3937	3947	–	–	–	–
Metric	Solid Top	Metric Micrometer	13 mm	M3902M	M3922M	M3932M	M3942M	M3952M	M3972M	M3982M	M3992M
		Imperial Micrometer	0.50 in	M3902	M3922	M3932	M3942	M3952	M3972	M3982	M3992
		Fine Screw	12,7 mm	M3903	M3923	M3933	M3943	–	–	–	–
	Aperture (12,7 mm)	Metric Micrometer	13 mm	M3906M	M3926M	M3936M	M3946M	M3956M	M3976M	M3986M	M3996M
		Imperial Micrometer	0.50 in	M3906	M3926	M3936	M3946	M3956	M3976	M3986	M3996
		Fine Screw	12,7 mm	M3907	M3927	M3937	M3947	–	–	–	–



Dimensions in (mm)

For additional end view dimensions, refer to the 3900/M3900 ball side drawing, page 20. Consult factory for critical dimension concerns.

Center Drive

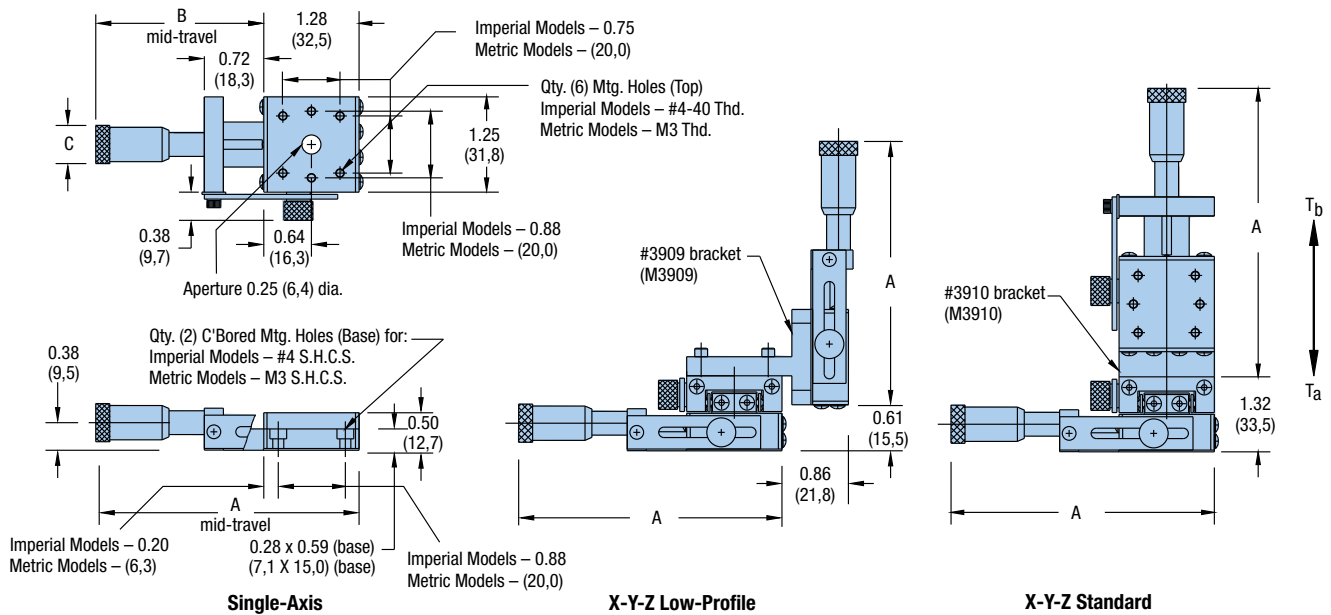

Ball Bearing Positioners

Style	Drive Mechanism	Travel	Imperial Model Dimensions – in			Metric Model Dimensions – mm		
			A	B	C	A	B	C
Solid Top	Imperial Micrometer	0.50 in	3.35	2.06	0.54	85,0	52,4	0.54
	Metric Micrometer	13 mm	3.35	2.06	0.54	85,0	52,4	0.54
	Fine Screw	0.50 in	2.32	1.03	0.58	58,3	25,9	0.58
Aperture	Imperial Micrometer	0.50 in	3.35	2.06	0.54	85,0	52,4	0.54
	Metric Micrometer	13 mm	3.35	2.06	0.54	85,0	52,4	0.54
	Fine Screw	0.50 in	2.32	1.03	0.58	58,3	25,9	0.58

Side Drive

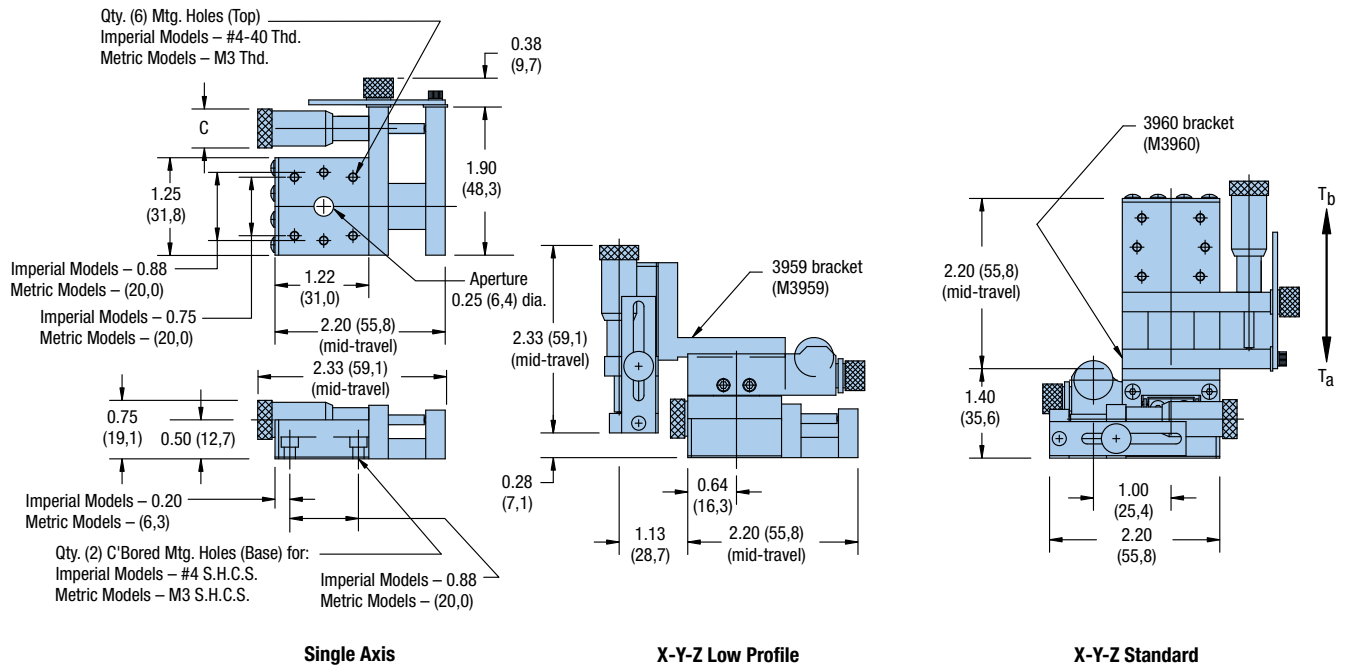

Yaw, Pitch, Roll

Yaw & Pitch **Roll**

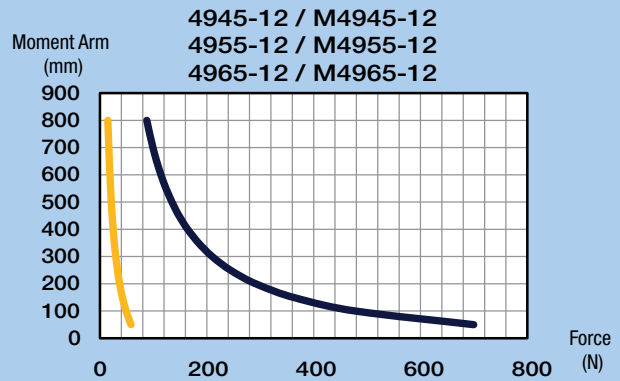
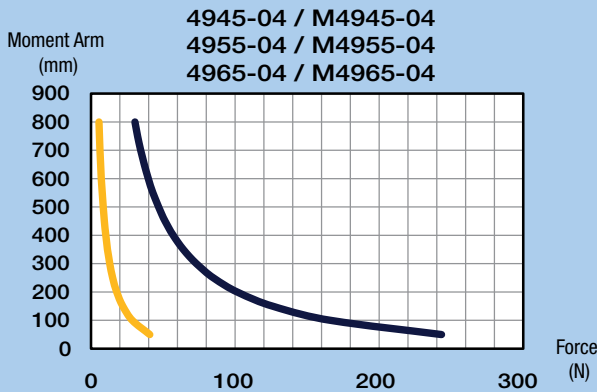
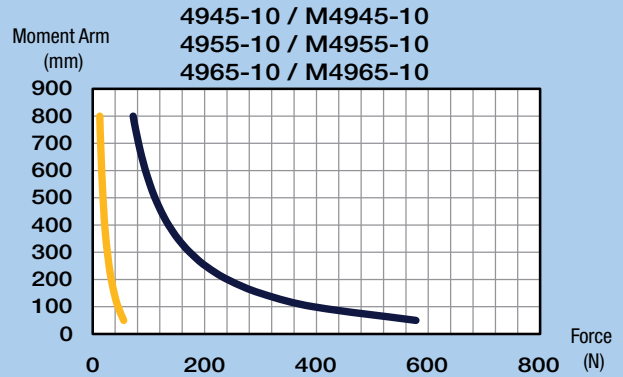
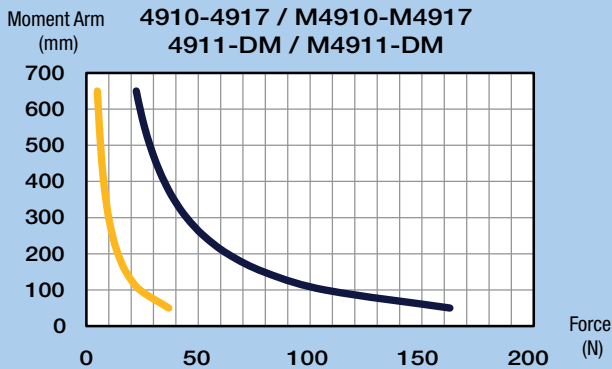
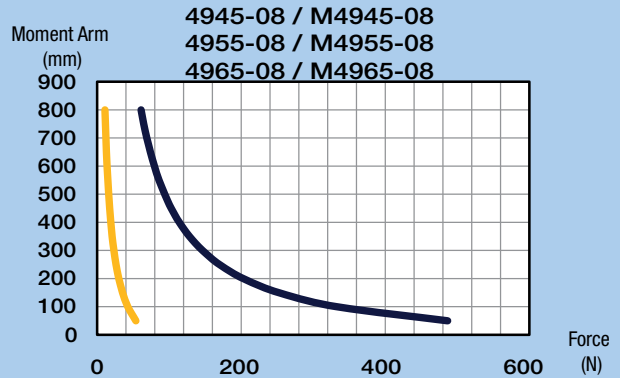
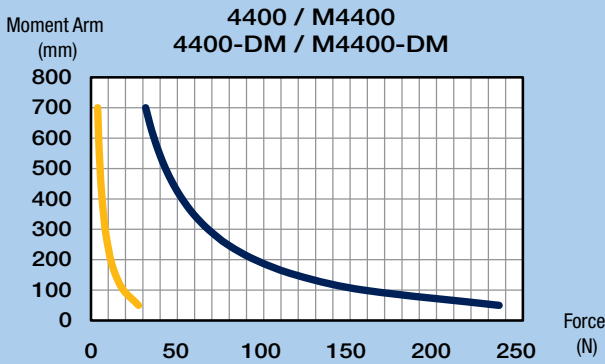
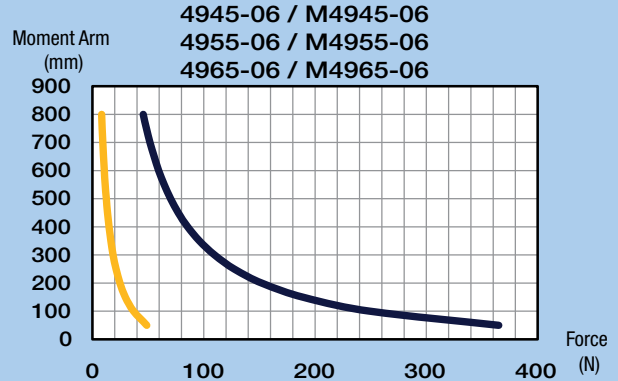
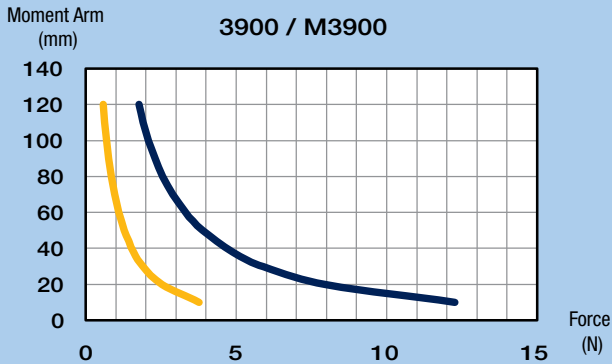

Accessories for linear and rotary positioners



Parker Daedal offers a complete line of Z-axis brackets to combine ball bearing and cross roller stages into three axis positioning systems. We also offer drive mechanisms in an assortment of standard and digital micrometer heads, fine adjustment screws, and differential screws. Optical components including beam directors, optical mounts, mirror mounts and optical cells are also available.

Contents

124-127	Z-Axis Brackets
128-129	Micrometer Heads
130-132	Optical Mounts

Z-Axis Brackets

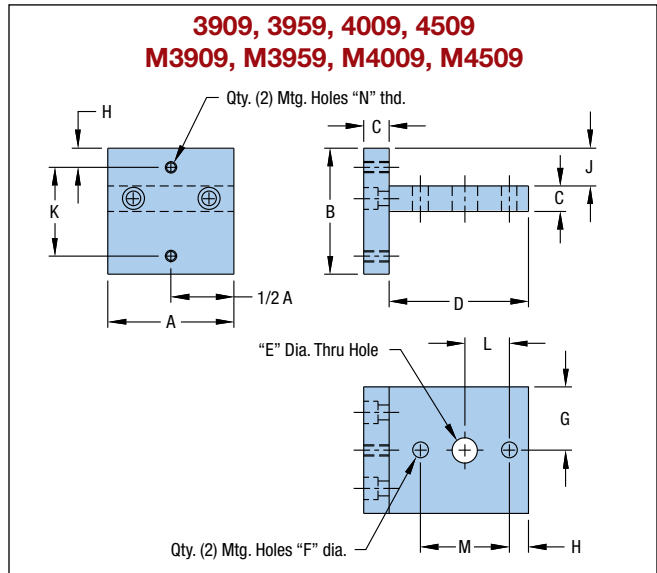

		Dimensions – in (mm)											Thd. N	
	Model	A	B	C	D	E	F	G	H	J	K	L	M	
Imperial	3909	1.25	1.25	0.25	1.38	0.25	0.156	0.62	0.19	0.38	0.88	0.44	0.88	#4-40
	3959	1.25	1.25	0.25	1.38	0.25	0.156	0.62	0.19	0.04	0.88	0.44	0.88	#4-40
	4009	1.75	1.69	0.25	1.88	—	0.156	0.88	0.31	0.63	1.12	—	1.12	#6-32
	4509	2.44	2.62	0.38	2.75	—	0.218	1.22	0.31	0.93	2.00	—	2.00	#10-32
Metric	M3909	(31,8)	(31,8)	(6,4)	(35,1)	(6,4)	(4,0)	(15,7)	(5,9)	(9,7)	(20,0)	(10,0)	(20,0)	M3
	M3959	(31,8)	(31,8)	(6,4)	(35,1)	(6,4)	(4,0)	(15,7)	(5,9)	(1,0)	(20,0)	(10,0)	(20,0)	M3
	M4009	(44,5)	(42,9)	(6,4)	(47,8)	—	(4,8)	(22,4)	(7,3)	(16,0)	(30,0)	—	(30,0)	M4
	M4509	(62,0)	(66,5)	(9,7)	(69,9)	—	(7,3)	(31,0)	(8,4)	(23,6)	(50,0)	—	(50,0)	M6

**3910, 3960
M3910, M3960**

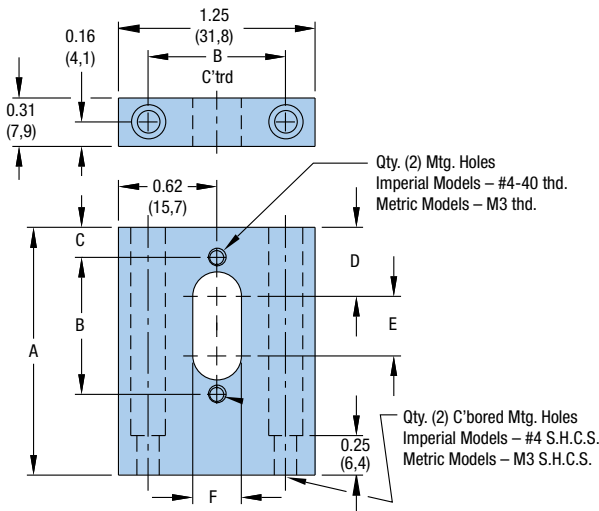

		Dimensions – in (mm)					
	Model	A	B	C	D	E	F
Imperial	3910	1.58	0.88	0.19	0.44	0.38	0.31
	3960	2.33	0.88	0.19	0.44	0.38	0.31
Metric	M3910	(40,1)	(20,0)	(5,9)	(12,3)	(7,1)	(6,4)
	M3960	(59,2)	(20,0)	(5,9)	(12,3)	(7,1)	(6,4)

**4010, 4020
M4010, M4020**

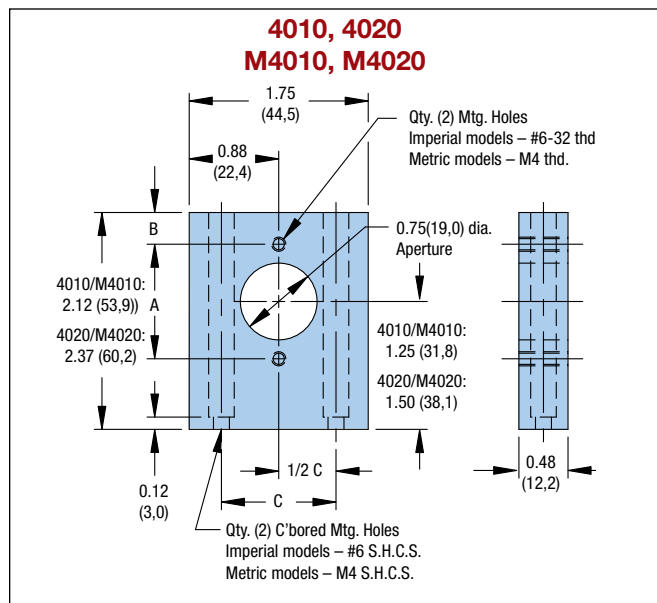

		Dimensions – in (mm)		
	Model	A	B	C
Imperial	4010	1.12	0.31	1.12
Metric	M4010	(30,0)	(7,1)	(30,0)

4059 M4059

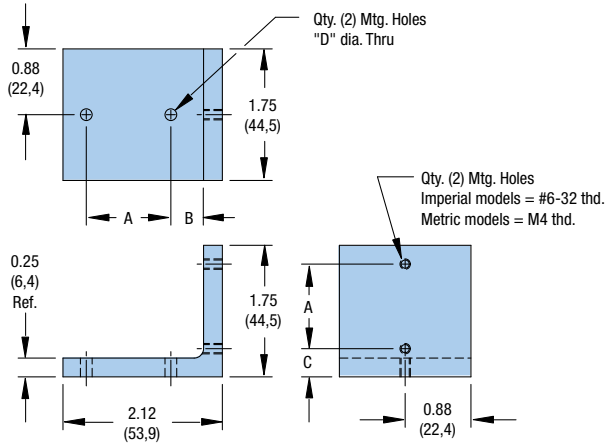

4059A M4059A

For 1.00 inch (25,0 mm) Travel Micrometer Option

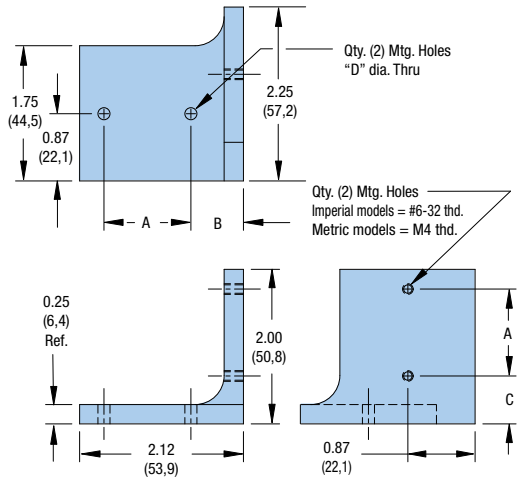

Dimensions - in (mm)

	Model	A	B	C	D
Imperial	4059	1.12	0.68	0.38	0.16
Metric	M4059	(30,0)	(16,8)	(8,8)	(4,8)

Dimensions - in (mm)

	Model	A	B	C	D
Imperial	4059A	1.12	0.68	0.62	0.16
Metric	M4059A	(30,0)	(16,8)	(15,2)	(4,8)

4060 M4060

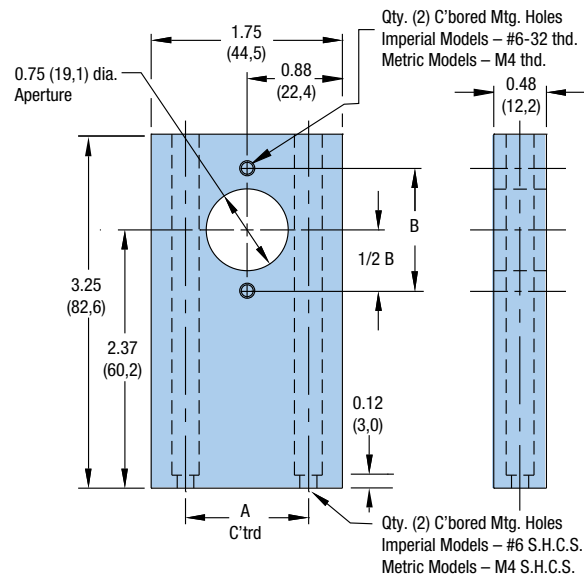

Dimensions - in (mm)

	Model	A	B
Imperial	4060	1.13	1.13
Metric	M4060	(30,0)	(30,0)

4510 M4510

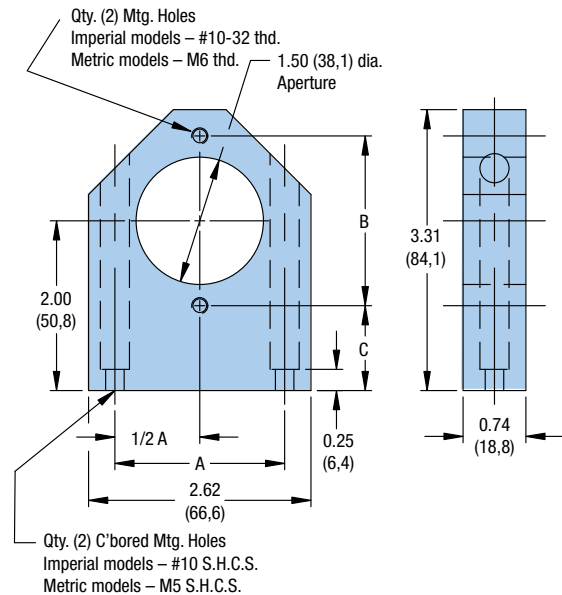

Dimensions - in (mm)

	Model	A	B	C
Imperial	4510	2.00	2.00	1.00
Metric	M4510	(50,0)	(50,0)	(25,8)

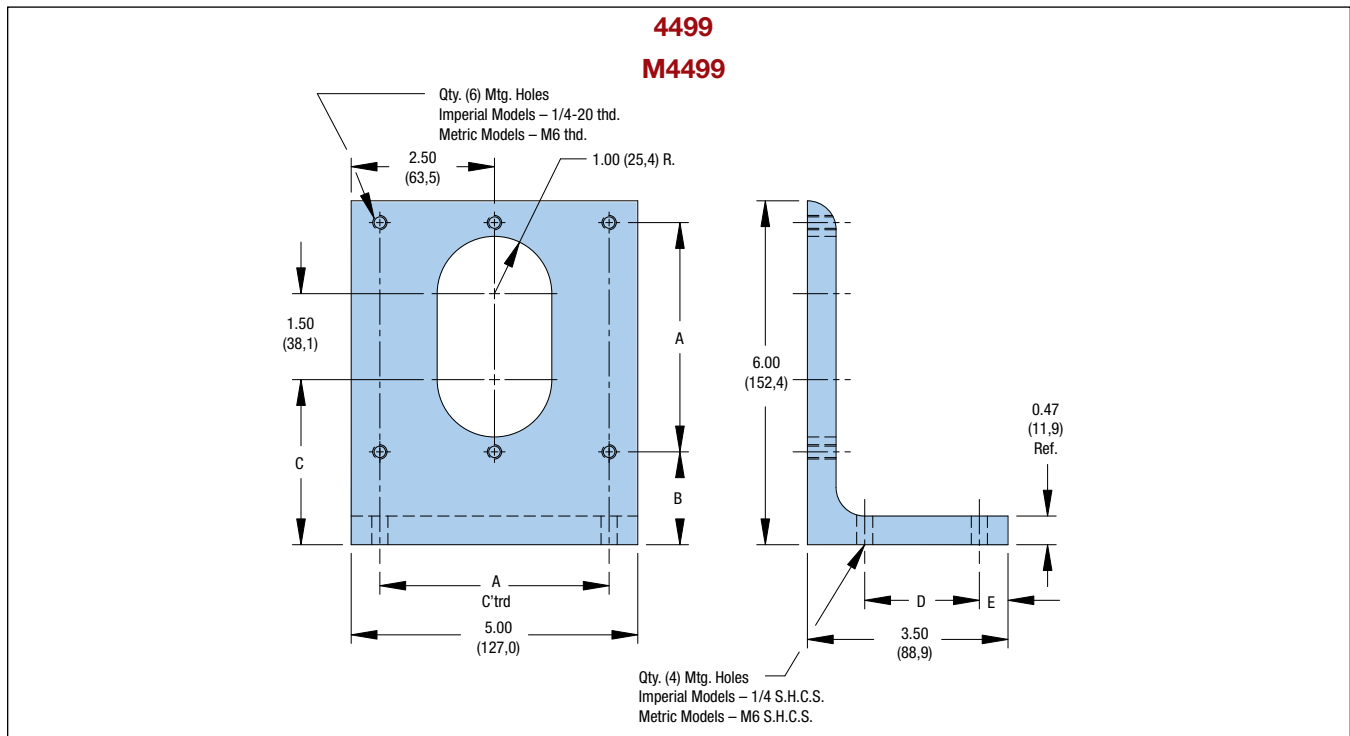

Dimensions - in (mm)					
	Model	A	B	C	E
Imperial	4499	4.00	1.62	2.88	0.50
Metric	M4499	(100,0)	(40,5)	(71,4)	(13,1)

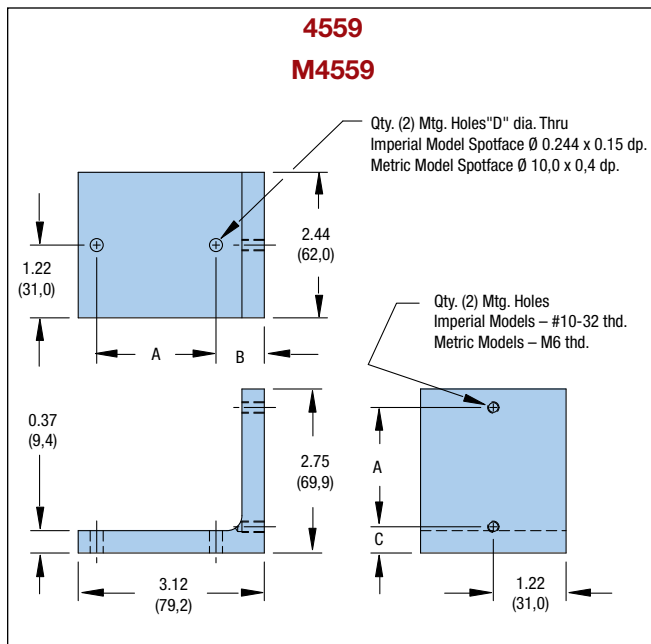

Dimensions - in (mm)				
	Model	A	B	D
Imperial	4559	2.00	0.81	0.22
Metric	M4559	(50,0)	(20,9)	(11,5)

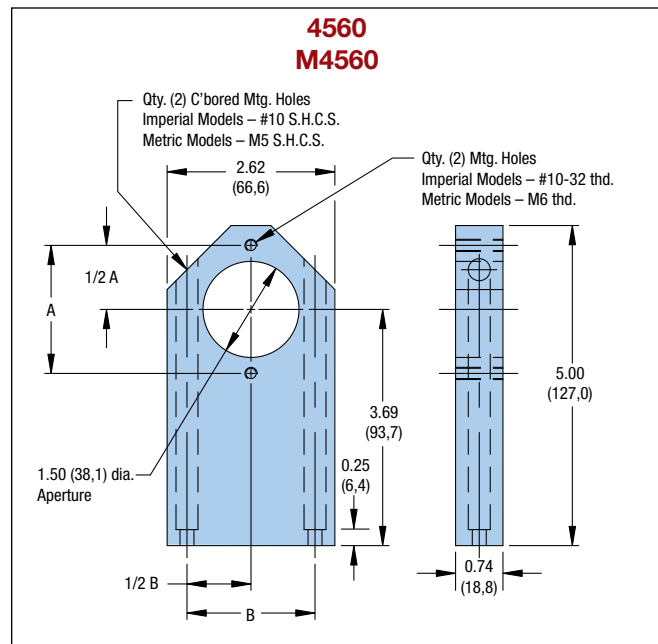

Dimensions - in (mm)		
	Model	B
Imperial	4560	2.00
Metric	M4560	(50,0)

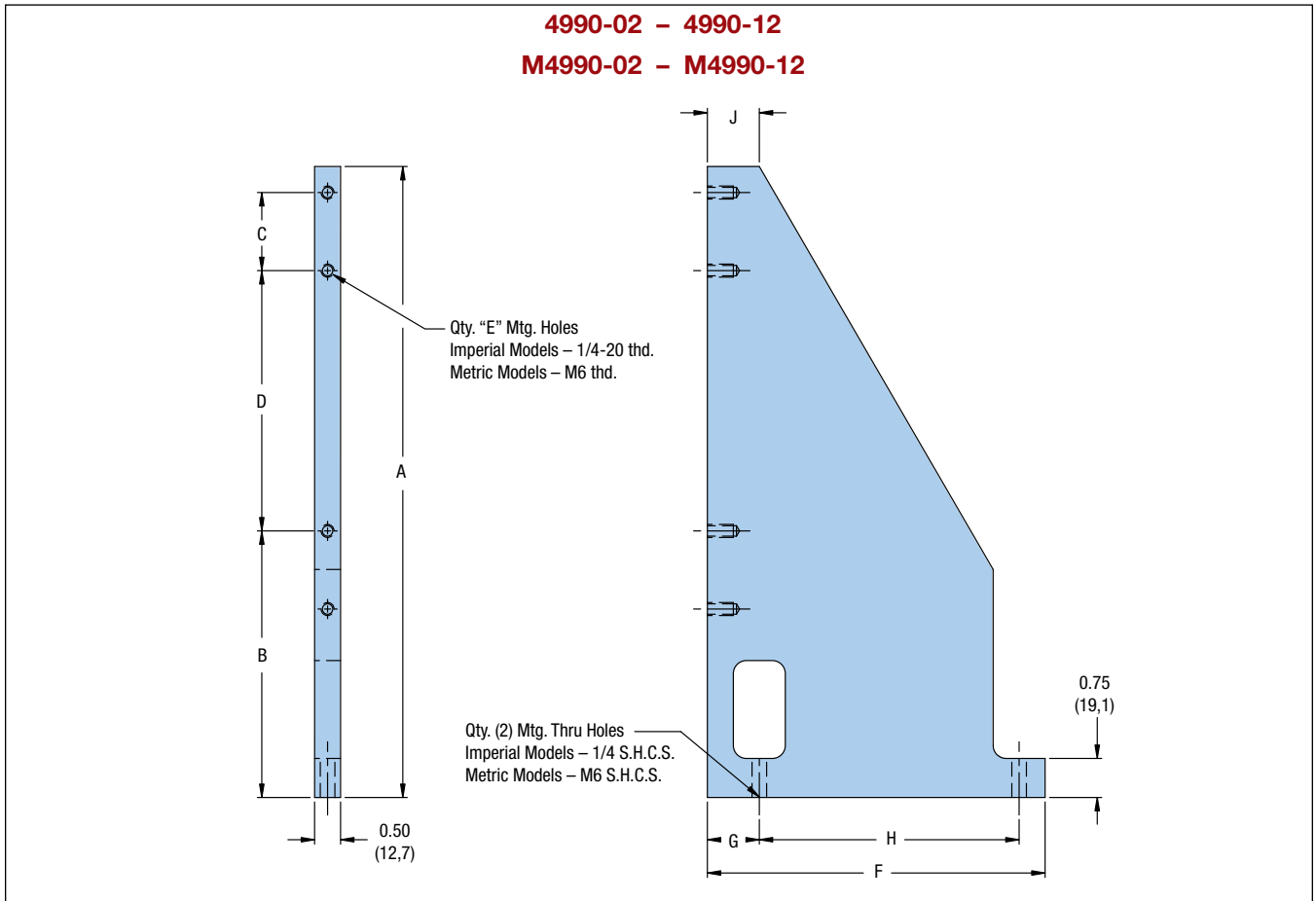

		Dimensions - in (mm)									
	Model	A	B	C	D	E	F	G	H	J	
Imperial	4990-02	6.00	1.50	-	4.00	2	5.50	1.00	4.00	1.00	
	4990-04	8.12	2.62	-	5.00	2	6.50	1.00	5.00	1.00	
	4990-06	12.12	5.12	1.5	5.00	4	6.50	1.00	5.00	1.00	
	4990-08	17.12	8.62	3.0	5.00	4	6.75	1.25	5.00	1.50	
	4990-10	20.50	10.00	4.0	6.00	4	6.75	1.25	5.00	1.50	
	4990-12	24.12	11.62	5.0	7.00	4	6.50	1.00	5.00	1.00	
Metric	M4990-02	(152,4)	(38,9)	-	(100,0)	2	(139,7)	(26,2)	(100,0)	(25,4)	
	M4990-04	(206,2)	(67,6)	-	(125,0)	2	(165,1)	(26,4)	(125,0)	(25,4)	
	M4990-06	(307,8)	(131,2)	(37,5)	(125,0)	4	(165,1)	(26,4)	(125,0)	(25,4)	
	M4990-08	(434,8)	(220,0)	(75,0)	(125,0)	4	(171,5)	(32,8)	(125,0)	(38,1)	
	M4990-10	(520,7)	(255,2)	(100,0)	(150,0)	4	(171,5)	(32,8)	(125,0)	(38,1)	
	M4990-12	(612,6)	(296,6)	(125,0)	(175,0)	4	(171,5)	(32,8)	(125,0)	(38,1)	

Accessories

9510-9530 Series Micrometer Heads

Parker Daedal micrometer heads are recommended for any application requiring micrometer accuracy in settings and adjustment. These units feature a hardened and ground spindle, easy-to-read graduations, and an attractive non-glare satin chrome finish.

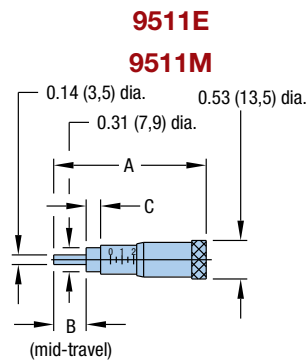

Figure A
Mini Thimble Micrometer Head

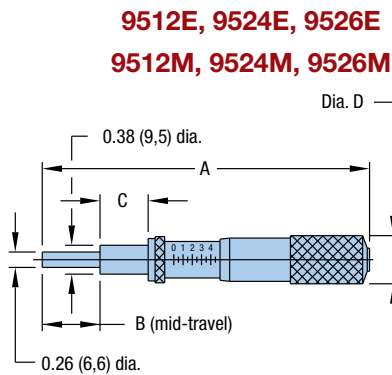

Figure B
Standard Thimble Micrometer Head

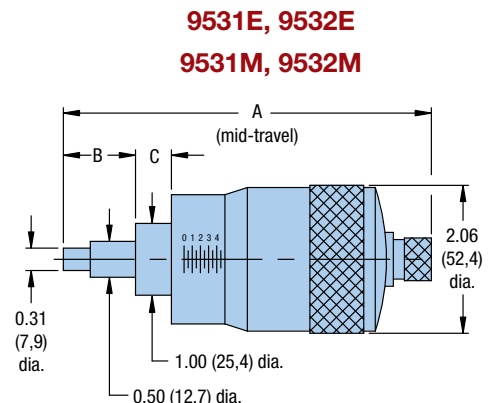

Figure C
Large Thimble Micrometer Head

		Model Number	Figure	Travel in (mm)	Graduations in (mm)	Dimensions – in (mm)			
						A	B	C	D
Imperial		9511E	A	0.50	0.001	2.03	0.50	0.187	—
		9512E	B	0.50	0.001	2.63	0.50	0.375	0.54
		9524E	B	1.00	0.001	4,23	0.75	0.625	0.73
		9526E	B	2.00	0.001	6.16	1.25	0.625	0.73
		9531E	C	1.00	0.0001	5.18	0.94	0.56	—
		9532E	C	2.00	0.0001	7.18	1.44	0.56	—
Metric		9511M	A	(13)	(0,01)	(51,6)	(13,0)	(4,7)	—
		9512M	B	(13)	(0,01)	(66,8)	(13,0)	(9,5)	(13,7)
		9524M	B	(25)	(0,01)	(107,4)	(19,0)	(15,9)	(18,5)
		9526M	B	(50)	(0,01)	(156,5)	(32,0)	(15,9)	(18,5)
		9531M	C	(25)	(0,002)	(131,6)	(23,9)	(14,2)	—
		9532M	C	(50)	(0,002)	(182,4)	(36,6)	(14,2)	—

9550 Series Digital Micrometer Heads

Model 9551

The 9551 precision electronic digital micrometer head provides an LCD readout to 0.00005 inch resolution. The micrometer features:

- Incremental and/or absolute positioning modes
- Zero set at any position, inch and millimeter readout (0.001 mm resolution), display hold, and automatic shutdown after two hours to conserve the integral battery
- 1.00 inch micrometer travel
- Battery powered for 500 hours of use

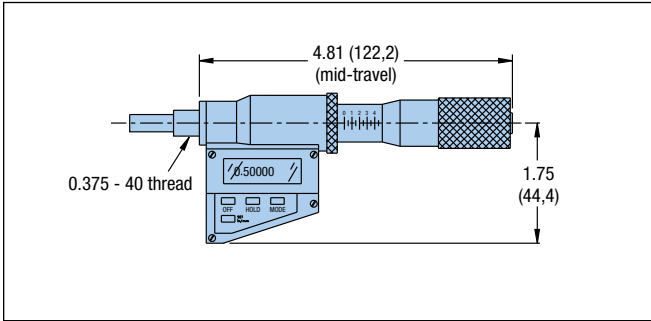

Model 9552

The 9552 precision electronic digital micrometer offers a 0 – 2 inch travel range with a 0.00005 inch resolution. Features include:

- 2 inch spindle
- Display face swivels for easy reading at various angles
- Non-rotating spindle
- Pre-set, zero, and inch/mm
- Carbide tipped measuring face
- Battery powered for 5,000 hours of use

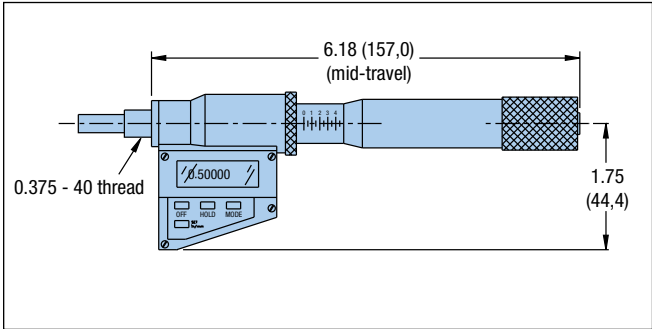

9560 Series Differential Screws

Model 9560: 0.75 in Range

The 9560 differential screw offers two linear adjustment ranges in one unit: a coarse adjustment range of 0.31 in (8 mm) with a 48-pitch thread and a fine adjustment range of 0.078 in (2 mm) with a pitch equal to 336 threads per inch. The 9560 is interchangeable with 9511 – 9532 series micrometer heads.

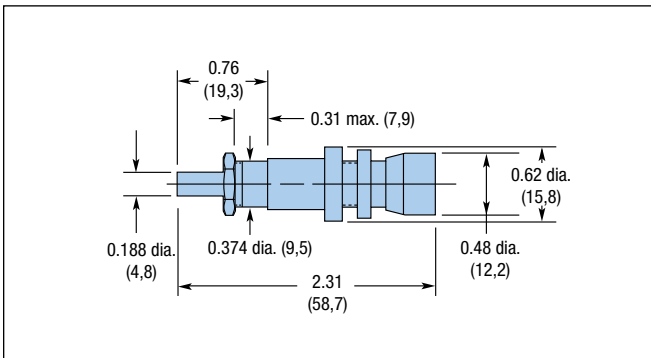

9570 Series Fine Adjustment Screws

Model 9570: 0.75 in Range

Model 9575: 0.50 in Range

These steel adjustment screws feature a 64-pitch thread, making them ideal for applications where finer resolution is required, but positional readout is not. These screws are easily interchanged with the 9511 – 9532 series micrometer heads.

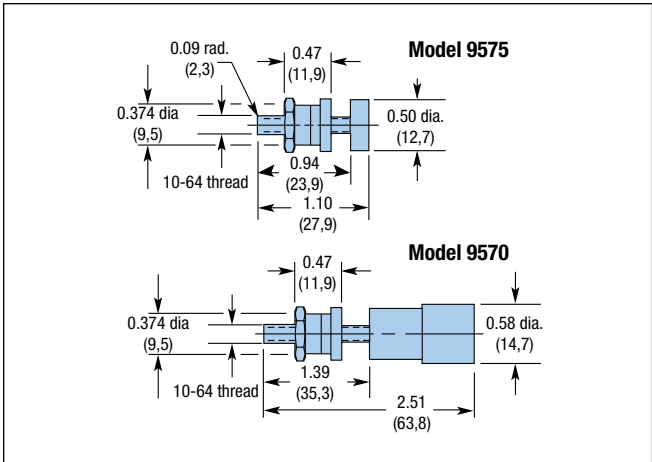

Accessories

Optical Cell Mounts

Model 2350: 6.0” Diameter

Model 2355: 7.0” Diameter

Model 2360: 8.0” Diameter

Model 2365: 9.0” Diameter

Parker Daedal optical mounts are highly stable, adjustable mounts for optics up to 9” in diameter and 1.25” thick. These mounts feature precise kinematic ball pivot adjustment on two axes, with orthogonal three-point suspension.

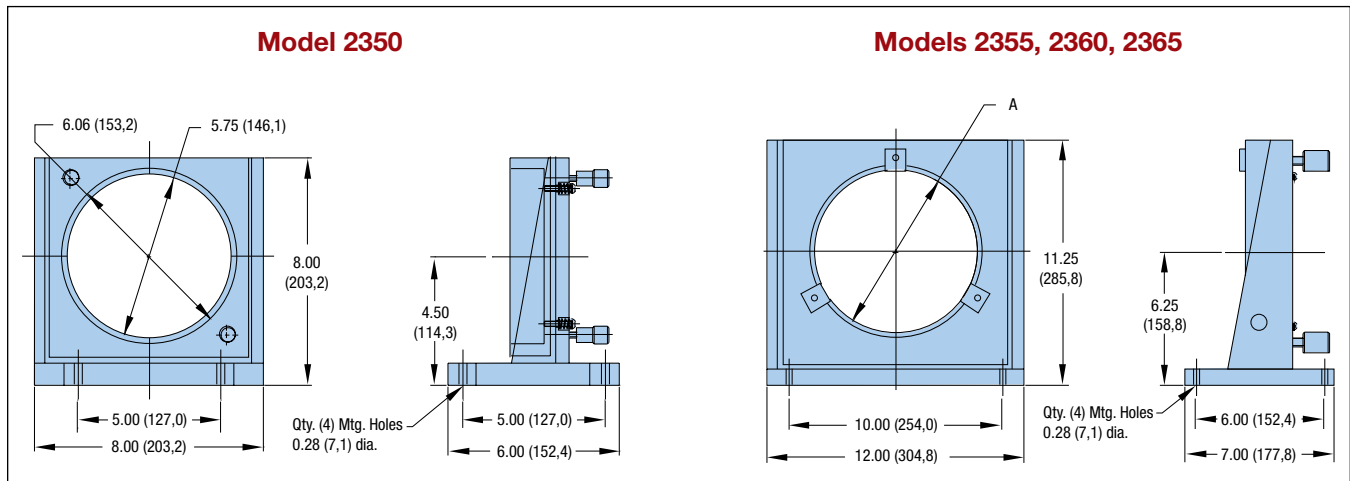

Specifications	2350	2355	2360	2365
Optic Size Opening – in (mm)				
Dimension “A” Dia. max.:	6.03 (153,1)	7.06 (179,3)	8.06 (204,7)	9.06 (230,1)
Thickness:	1.00 (25,4)	1.25 (31,75)	1.25 (31,7)	1.25 (31,7)
Optic Retention:	Threaded retainer	3 mounting clips	3 mounting clips	3 mounting clips
Range:	5°	5°	5°	5°
Resolution:	0.5 arc-sec	0.5 arc-sec	0.5 arc-sec	0.5 arc-sec
Adjustment:	2 – 64-pitch screws	3 – 32-pitch screws	3 – 32-pitch screws	3 – 32-pitch screws
Weight:	7.5 lb (16,5 kg)	20 lb (44 kg)	20 lb (44 kg)	20 lb (44 kg)
Construction:	Aluminum/stainless steel			
Finish:	Black anodize			

Optical Cell Mounts

Model 2370/2371: 10.0" Diameter

Model 2375/2376: 11.0" Diameter

Model 2380/2381: 12.0" Diameter

Parker Daedal optical mounts are highly stable, adjustable mounts for optics up to 12" in diameter and 2.0" thick. These mounts feature precise kinematic ball pivot adjustment on two axes, with orthogonal three-point suspension. Solid back models are designed to support reflective optics.

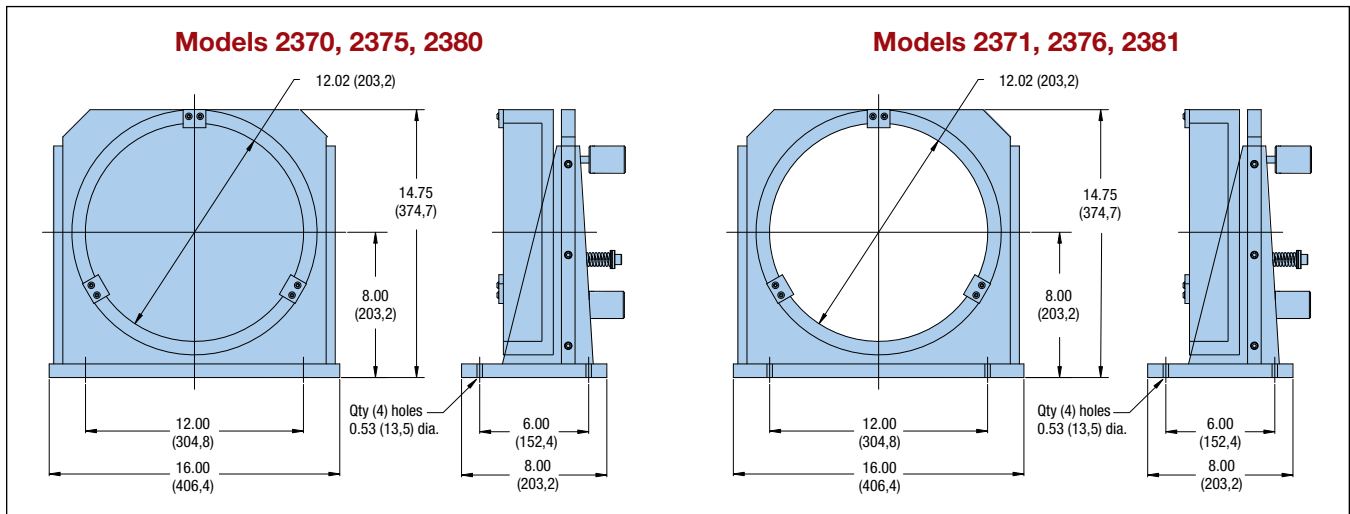
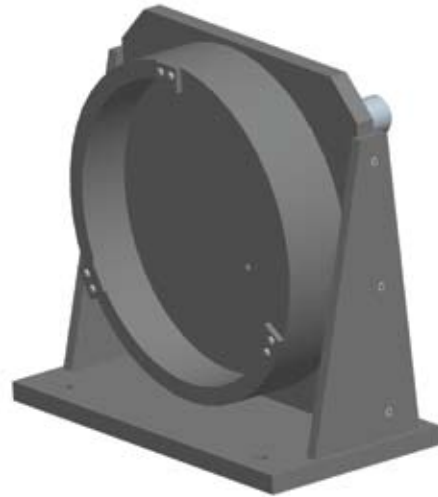

Specifications	Solid Back Models			Aperture Models		
	2370	2375	2380	2371	2376	2381
Optic Size Opening – in (mm)						
Dimension "A" Dia. max.:	10.02 (254,5)	11.02 (379,9)	12.02 (305,3)	10.06 (255,5)	11.06 (280,9)	12.06 (306,3)
Thickness:	2.00 (50,8)	2.00 (50,8)	2.00 (50,8)	2.00 (50,8)	2.00 (50,8)	2.00 (50,8)
Optic Retention:	3 mounting clips			3 mounting clips		
Range:	7°			7°		
Resolution:	0.5 arc-sec			0.5 arc-sec		
Adjustment:	3 – 32-pitch screws			3 – 32-pitch screws		
Weight:	45 lb (99 kg)			41 lb (90 kg)		
Construction:	Aluminum/stainless steel			Aluminum/stainless steel		
Finish:	Black anodize			Black anodize		

Accessories

Mirror Mounts

Model 5000/5100: 3.0" Square Mounting Surface

Model 5300/5700: 4.5" Square Mounting Surface

Model 5800/5900: 6.0" Square Mounting Surface

Parker Daedal mirror mounts are patterned with 1/4-20 holes on 0.5" or 1.0" centers to mount mirrors and other hardware. All models except the 5800 have two fine resolution 64-pitch adjustment screws to provide precise tilting of the mounting surface in two axes. The 5800 is equipped with three adjustment screws to provide precise tilting in two axes.

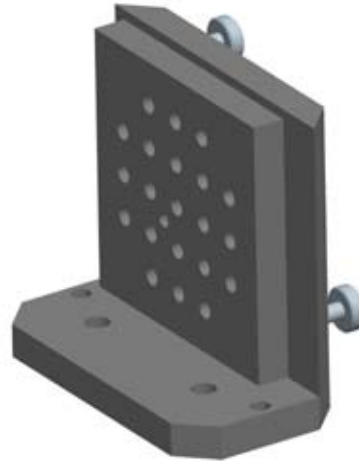

Specifications	Angled Base Models			Flat Base Models		
	5000	5300	5800	5100	5700	5900
Mounting Surface						
Size (Square) – in (mm)	3.0 (76,2)	4.5 (114,3)	6.0 (152,4)	3.0 (76,2)	4.5 (114,3)	6.0 (152,4)
Holes – (Qty. x Center)	21 x 0.50"	49 x 0.50"	25 x 1.0"	21 x 0.50"	49 x 0.50"	25 x 1.0"
Range:	12°	8°	4°	12°	8°	4°
Resolution:	1.0 arc-sec	0.75 arc-sec	0.5 arc-sec	1.0 arc-sec	0.75 arc-sec	0.5 arc-sec
Weight – lb (kg)	1 (2,2)	2 (4,4)	4.1 (9)	0.7 (1,5)	1.6 (3,5)	3 (6,6)
Adjustment:	2 – 64-pitch screws (3 screws on 5800)			2 – 64-pitch screws		
Construction:	Aluminum/stainless steel			Aluminum/stainless steel		
Finish:	Black anodize			Black anodize		

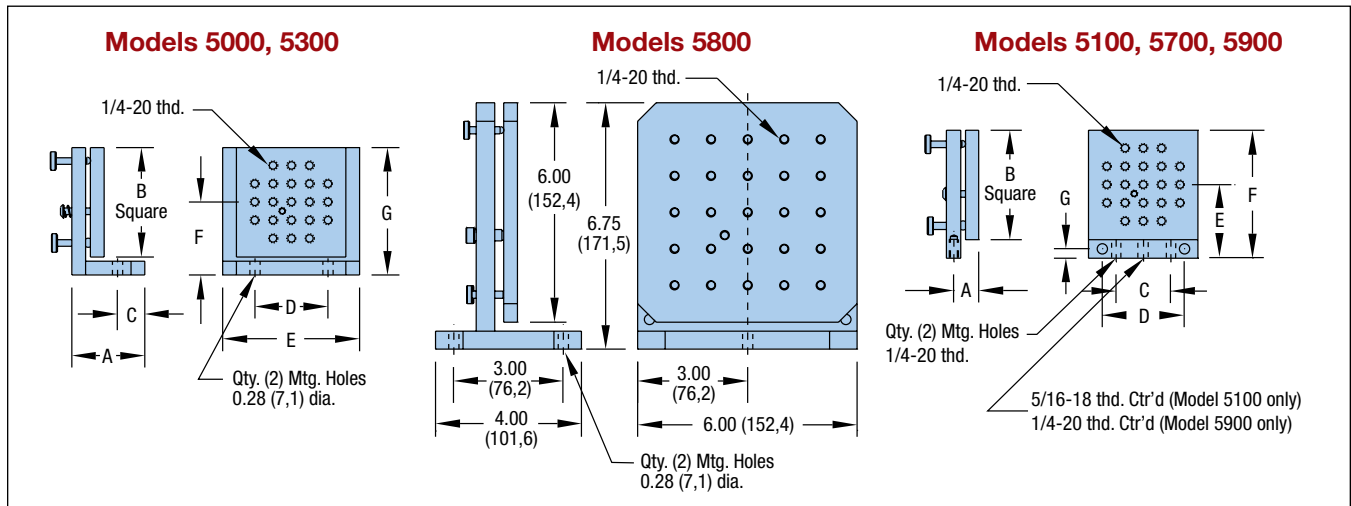

Model	Dimensions – in (mm)						
	A	B	D	D	E	F	G
5000	2.00 (50,8)	3.00 (76,2)	0.75 (19,1)	2.00 (50,8)	3.75 (95,3)	2.00 (50,8)	3.50 (88,9)
5300	3.00 (76,2)	4.50 (114,3)	1.25 (31,8)	4.00 (101,6)	4.50 (114,3)	2.88 (73,2)	5.12 (130,1)
5100	0.69 (17,5)	3.00 (76,2)	1.50 (38,1)	2.25 (57,2)	2.00 (50,8)	3.50 (88,9)	0.25 (6,4)
5700	0.69 (17,5)	4.50 (114,3)	3.00 (76,2)	3.75 (95,3)	2.88 (73,2)	5.12 (130,1)	0.25 (6,4)
5900	0.88 (2,4)	6.00 (152,4)	4.00 (101,6)	5.38 (136,7)	3.25 (82,6)	6.25 (158,8)	0.31 (7,9)

Travel

The travel listed is the total travel of the positioner from hard stop to hard stop.

Bearing Load Capacity

Normal Load

This is the maximum downward (compression) load or force which can be applied to the positioner perpendicular to the mounting surface. The center of force or the C.G. of the load must be located in the center of the mounting surface. For loads which are offset from this position, refer to moment loads.

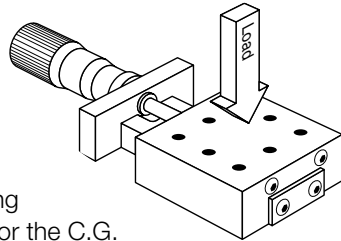

Inverted Load

Same as a normal load except in an upward (tension) direction.

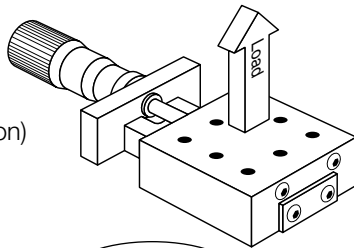

Moment Load

This refers to forces which are offset (cantilevered) from the bearing centers and therefore producing uneven loading on the bearings. This uneven loading means that some bearings are supporting more of the load than others. For this reason it is very important to determine if the moment loading for a given positioner is within acceptable limits. These moment forces are categorized by the direction they act in Pitch, Roll or Yaw; see diagram at left. When loading results in moments acting in only one of the moment directions (pitch, roll or yaw) it is called a single direction moment. Examples of this type of loading are shown below. How to calculate the maximum allowable moment load is discussed on the following page.

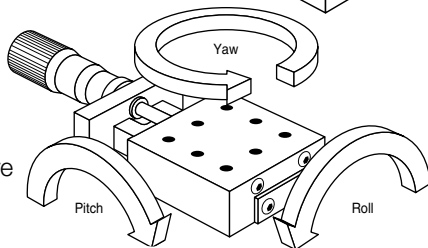

Thrust Capacity

Thrust capacity is the maximum force or load which can be applied in the direction of travel without damage to positioning stage components.

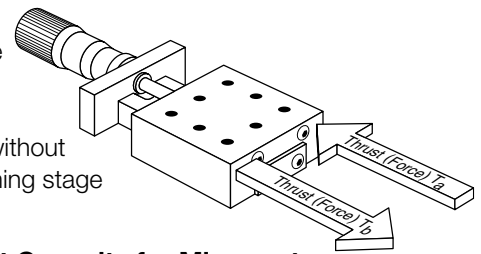

T_a and T_b Thrust Capacity for Micrometer, Fine Screw and Differential Screw Drives

With these types of drives the mounting surface or stage carriage is pressed against the drive mechanism by means of a spring. Because of this the maximum thrust which the stage assembly can maintain is different when pressing toward the spring or away from it. When pressing toward the spring, the force is taken up by the drive mechanism (i.e. micrometer). While pulling away, the force is being held in place by the spring. Stages with this type of mechanism have two thrust capacity specifications (T_a and T_b). T_a refers to the load capacity against the micrometer and T_b is the spring load capacity. Refer to specific product drawings for load direction.

Screw Drive Thrust Capacity

Stages which use screw drive assemblies will only have one thrust capacity rating. This rating is for either direction of travel.

Straight Line and Flatness Accuracy

This is the amount of error a linear positioner deviates from an ideal straight line. The straight line accuracy is the error in the horizontal plane while flatness is the error in the vertical plane. Both the straight line and the flatness accuracy are measured at the moving carriage surface center.

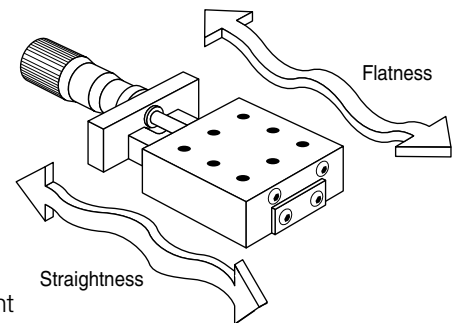

Pitch Moment

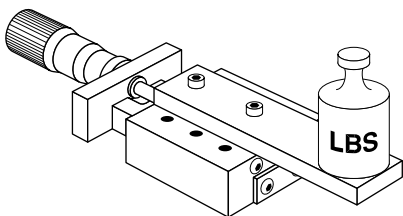

Roll Moment

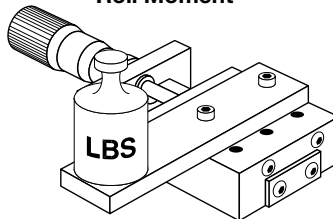

Compound Pitch/Roll Moment

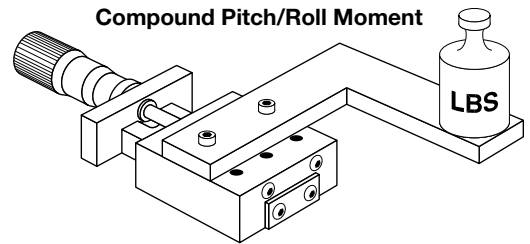

Calculating Maximum Allowable Moment Loads on Linear Slides and Stages

To determine if a load or force is within acceptable moment load ranges follow the steps below:

1. Calculate maximum load and or force which will be applied to the positioner. Include brackets and other axes which are mounted to the positioner.
2. Locate the center of gravity of the load.
3. Determine if there is a single or compound moment.
4. Measure the distance from the center of force or C.G. to the center of the linear stage carriage. This is the moment arm length and is designated A_S for single direction moments and A_C for compound moments.
5. Locate the moment load graph for the positioner you are interested in (located in back of individual product section, see example below). The X axis of the graph is the Force, the Y axis is the allowable moment arm A_S for single direction moments.
6. Locate the moment curve(s) which your load is acting in (pitch, roll or yaw).
7. Locate your load force on the X axis of the graph.
8. Draw a vertical line from the Force location on the X axis parallel with the Y axis.
9. Find the moment arm distance on the Y axis. Draw a horizontal line from this point parallel with the X axis until the vertical and horizontal lines intersect.
10. If the intersection point is below the moment curve in question then the stage is within acceptable limits. If the intersection point is above the moment curve, a positioner with a larger normal load capacity should be selected and the above steps repeated.

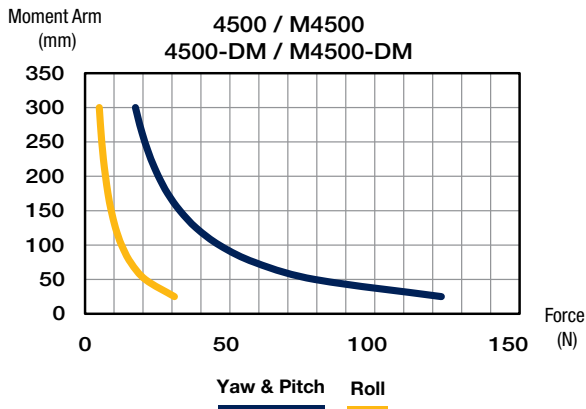

Example #1: Single Direction Moment Load

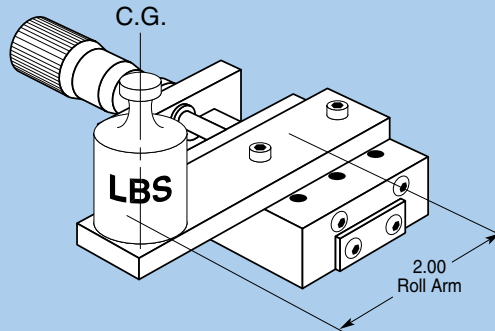

A 2 pound load is mounted to a single axis linear stage. The diagram shows the load's position in reference to the positioner carriage center. This shows that the load is offset 2 inches from the carriage center creating a roll moment.

The selected positioner is a 4502 ball stage. (The moment load curve for the 4502 is shown below.) First, find 2 pounds on the X axis and draw a vertical line. Next, draw a horizontal line starting at the 2 inches position on the A_S axis (single direction moment). Mark the intersection point.

In this example the intersection point is below the roll moment curve, indicating that the stage is acceptable for this application.

