

# Ball Bearing Slides

## miniature and standard

Parker Daedal miniature and standard size ball bearing slides are a popular solution for most applications requiring inexpensive yet accurate and reliable linear motion. Parker Daedal ball slides are offered in many different sizes and styles. Proper sizing and selection is based on travel, load, dimensional and mounting requirements, open aperture or solid top configurations, etc. Based on our large scale production and inventory capabilities, Parker Daedal offers exclusively precision grade ball slides at prices comparable to other brands of commercial quality products.

### Contents

<b>14-15</b>	Overview
<b>16-20</b>	1.25" (31,8 mm) Wide or Less
<b>21-22</b>	1.75" (44,5 mm) Wide
<b>23-25</b>	2.62" (66,5 mm) Wide
<b>26-27</b>	5.00" (127,0 mm) Wide
<b>28</b>	6.00" (152,4 mm) Wide
<b>29-34</b>	Performance Curves

## Miniature and Standard Size Ball Bearings Slides



- Precision quality
- Budget friendly
- Largest selection
- Easy multi-axis configuration
- No maintenance
- Vacuum preparation and custom options

### Ball Slide Design Principles

Parker Daedal ball slides are mechanically simple linear motion devices comprised of a stationary base member with a mobile carriage riding on top. Two rows of hardened steel balls on both sides of the base provide the smooth, accurate, low friction sliding motion between the stationary base and the top slide. Each row of bearings is contained between four hardened and precision ground steel rods. These bearing assemblies are factory preloaded to eliminate wobble and unwanted play in the system.

Ball slides are functionally much more reliable than simple dovetail slides, since there is no direct sliding contact of the top and bottom members. Ball slides eliminate the rapid wear problems, regular lubrication requirements, and “stiction” (skipping and jumping caused by the increased force needed to initiate movement) characteristic of dovetail slides. Parker Daedal also offers a high load capacity, long life crossed roller slides for applications requiring maximum load and life performance.

### Standard Features

All models offer high quality construction features as standard:

- Straight line accuracy of 0.00008 inches per inch of travel (0.00025 inches per inch of travel for miniatures)
- Precision machined mounting surfaces to assure flatness and parallelism
- Factory preloaded to precision specifications to eliminate any side play and provide a uniform coefficient of friction
- Factory threaded mounting holes on the top for easy payload mounting
- Factory machining services for special hole configurations and custom modifications
- Locking thread inserts on preloaded screws for maintenance-free life without loss of preload
- Hardened and precision machined 440C stainless steel balls and rods

### How to Order

Use the overview chart on the following page to select the appropriate ball slide. Refer to the individual specifications page for complete performance and mechanical specifications. To order ball slides, use the model number corresponding to the specific size and travel length selected. A variety of modifications to standard models are available to meet custom requirements. Contact our application engineering department with your design specifications.

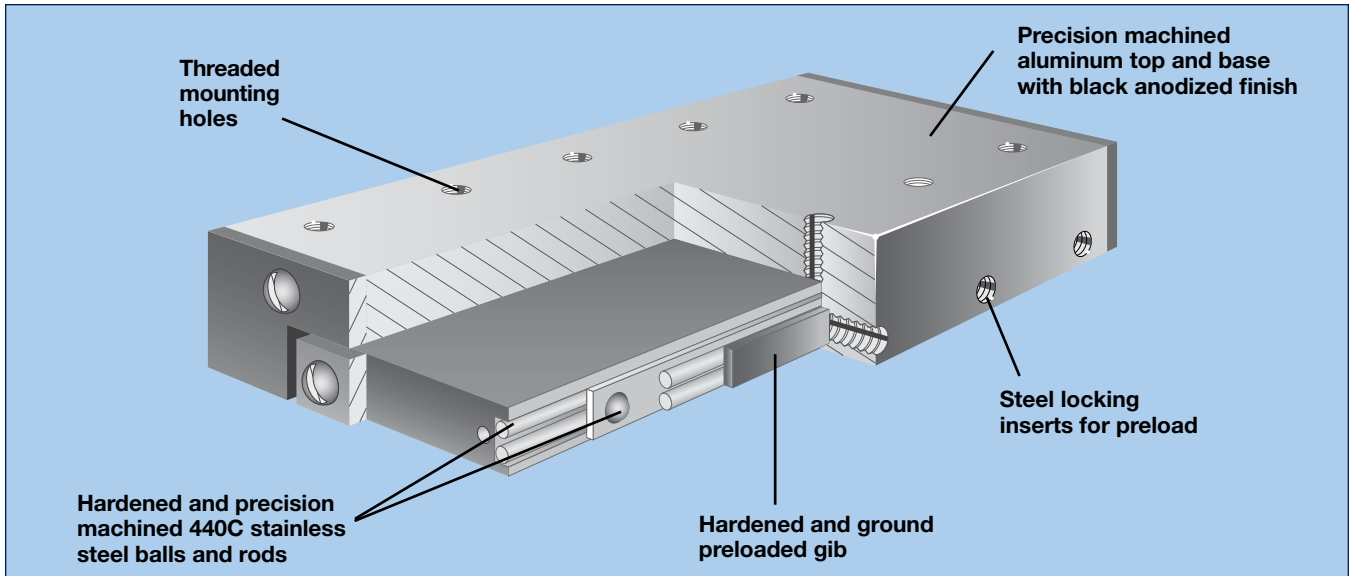

**Selection**

Series	Width in (mm)	Travel		Normal Load		Mounting		Page
		in	(mm)	lbs	(kg)	Imperial	Metric	
3500 3900	≤1.25 (≤31,8)	0.5	(12,7)	4.9	(2,2)	•		16
				5.0	(2,3)	•		17
				17.0	(7,6)	•		18
				6.0	(2,7)	•	•	20
		0.75	(19,1)	14.6	(6,6)	•		19
		1.00	(25,4)	10.3	(4,6)	•		16-17
		29.0	(13,1)	•		18		
		1.50	(38,1)	24.3	(11,0)	•		19
		2.00	(50,8)	14.0	(6,3)	•		16-17
		36.0	(16,3)	•		18-19		
3.00	(76,2)	23.0	(10,3)	•		16-17		
43.0	(19,5)	•		19				
4.00	(101,6)	56.0	(25,4)	•		19		
4000 4100 4200 4300	1.75 (44,5)	1.00	(25,4)	25	(13)	•	•	21
28	(13)	•	•	22				
2.00	(50,8)	40	(18)	•	•	•	22	
3.00	(76,2)	55	(25)	•	•	•	22	
1.0	(25,4)	62	(28)	•	•	•	23	
2.0	(50,8)	88	(40)	•	•	•	24	
3.0	(76,2)	106	(48)	•	•	•	24	
4.0	(101,6)	123	(56)	•	•	•	24	
6.0	(152,4)	154	(70)	•			25	
9.0	(228,6)	192	(87)	•			25	
12.0	(304,8)	205	(93)	•			25	
15.0	(381,0)	243	(110)	•			25	
18.0	(457,2)	281	(128)	•			25	
21.0	(533,4)	332	(151)	•			25	
24.0	(609,6)	391	(168)	•			25	
27.0	(685,8)	410	(186)	•			25	
30.0	(762,0)	448	(203)	•			25	
4400 4900	5.0 (127,0)	2.0	(50,8)	77	(35)	•	•	27
3.0	(75,0)	106	(48)	•	•	•	26	
4.0	(100,0)	100	(45)	•	•	•	28	
6.0	(150,0)	154	(70)	•	•	•	28	
8.0	(200,0)	205	(93)	•	•	•	28	
10.0	(250,0)	243	(110)	•	•	•	28	
12.0	(300,0)	294	(133)	•	•	•	28	



### 4000/M4000 Series

Specifications	Imperial	Metric
Travel:	1.0 in	25,4 mm
<b>Size:</b>		
Width	1.75 in	44,5 mm
Length	1.75 in	44,5 mm
Height	0.75 in	19,0 mm
<b>Load:</b>		
Normal	25 lbs	11 kg
Moment: Yaw, Pitch, Roll	See page 31	See page 31
<b>Straight line accuracy:</b>	0.00008 in/in of travel	2 µm/25 mm of travel
<b>Weight:</b>	0.2 lbs	0,09 kg
<b>Construction:</b>	Aluminum top and base/ 440C stainless steel bearings	
<b>Mounting surface:</b>	Precision machined	
<b>Finish:</b>	Black anodize	



Ball Bearing Slides

### Dimensions in (mm)

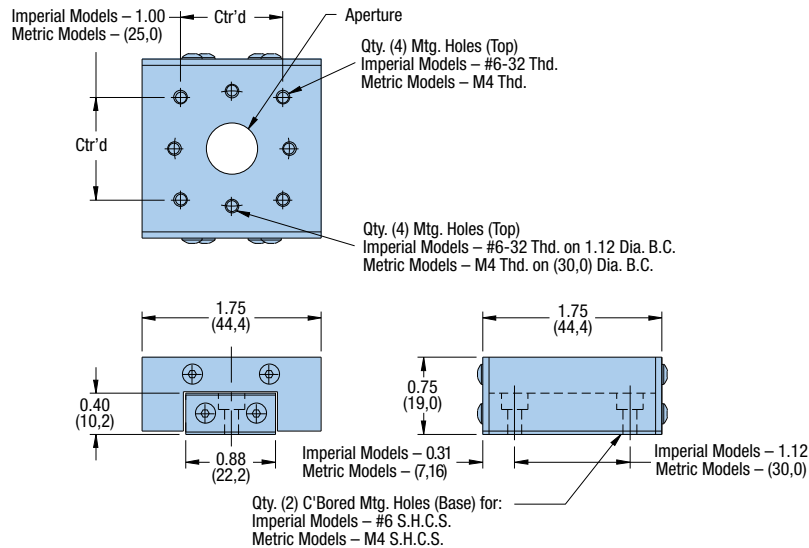

Model	Travel	Aperture
Imperial	4001	1.0 in
	4005	1.0 in
Metric	M4001	25,4 mm
	M4005	25,4 mm

**4100/M4100, 4200/M4200, 4300/M4300 Series**

Specifications	Imperial	Metric
Travel:	1.0 – 3.0 in	25,4 – 76,2 mm
<b>Size:</b>		
Width	1.75 in	44,5 mm
Length	2.00 – 4.00 in	50,8 – 101,6 mm
Height	0.75 in	
<b>Load:</b>		
Normal	28 – 55 lbs	13 – 25 kg
Moment: Yaw, Pitch, Roll	See page 31	See page 31
<b>Straight line accuracy:</b>	0.00008 in/in of travel	2 µm/25 mm of travel
<b>Weight:</b>	0.2 – 0.6 lbs	0,09 – 0,27 kg
<b>Construction:</b>	Aluminum top and base/ 440C stainless steel bearings	
<b>Mounting surface:</b>	Precision machined	
<b>Finish:</b>	Black anodize	



**Dimensions** in (mm)

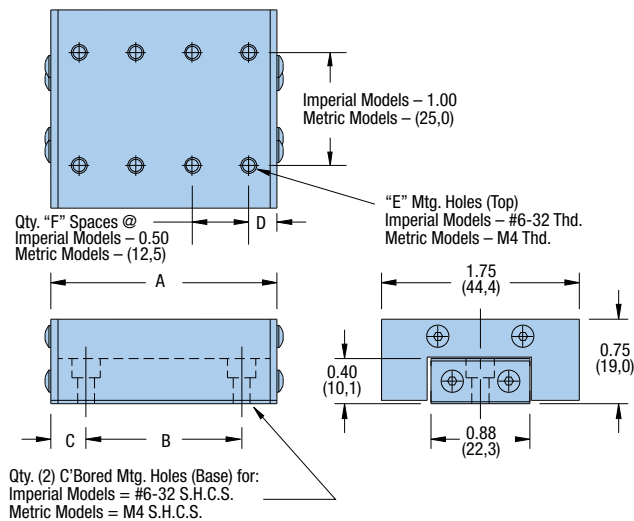

Model	Travel	Normal Load	Weight	Dimensions						
				A	B	C	D	E	F	
Imperial	4101	1.0 in	28 lbs	0.2 lbs	2.00 in	1.38 in	0.31 in	0.25 in	8	3
	4201	2.0 in	40 lbs	0.4 lbs	3.00 in	2.38 in	0.31 in	0.25 in	12	5
	4301	3.0 in	55 lbs	0.6 lbs	4.00 in	3.38 in	0.31 in	0.25 in	16	7
Metric	M4101	25,4 mm	13 kg	0,09 kg	50,8 mm	35,0 mm	7,8 mm	12,9 mm	6	2
	M4201	50,8 mm	18 kg	0,18 kg	76,2 mm	60,0 mm	8,1 mm	13,1 mm	10	4
	M4301	76,2 mm	25 kg	0,27 kg	101,6 mm	85,0 mm	8,3 mm	13,3 mm	14	6



**4500/M4500 Series**

Specifications	Imperial	Metric
Travel:	1.0 in	25,4 mm
<b>Size:</b>		
Width	2.62 in	66,5 mm
Length	2.62 in	66,5 mm
Height	1.00 in	25,4 mm
<b>Load:</b>		
Normal	62 lbs	28 kg
Moment: Yaw, Pitch, Roll	See page 31	See page 31
<b>Straight line accuracy:</b>	0.00008 in/in of travel	2 μm/25 mm of travel
<b>Weight:</b>	4501 – 0.6 lbs 4505 – 0.5 lbs	M4501 – 0,27 kg M4505 – 0,23 kg
<b>Construction:</b>	Aluminum top and base/ 440C stainless steel bearings	
<b>Mounting surface:</b>	Precision machined	
<b>Finish:</b>	Black anodize	



**Dimensions** in (mm)

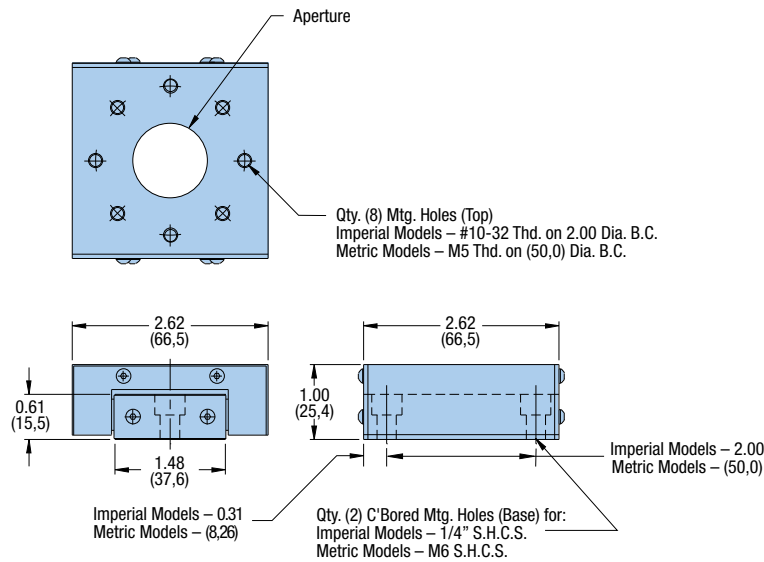

Model	Travel	Aperture
Imperial	4501	1.0 in
	4505	1.0 in
Metric	M4501	25,4 mm
	M4505	25,4 mm

**4600/M4600, 4700/M4700, 4800/M4800 Series**

Specifications	Imperial	Metric
Travel:	2.0 – 4.0 in	50,8 – 101,6 mm
<b>Size:</b>		
Width	2.62 in	66,5 mm
Length	4.00 – 6.00 in	101,6 – 152,4 mm
Height	1.00 in	
<b>Load:</b>		
Normal	88 – 123 lbs	40 – 56 kg
Moment: Yaw, Pitch, Roll	See page 32	See page 32
<b>Straight line accuracy:</b>	0.00008 in/in of travel	2 µm/25 mm of travel
<b>Weight:</b>	0.9 – 1.4 lbs	0,41 – 0,64 kg
<b>Construction:</b>	Aluminum top and base/ 440C stainless steel bearings	
<b>Mounting surface:</b>	Precision machined	
<b>Finish:</b>	Black anodize	



**Dimensions** in (mm)

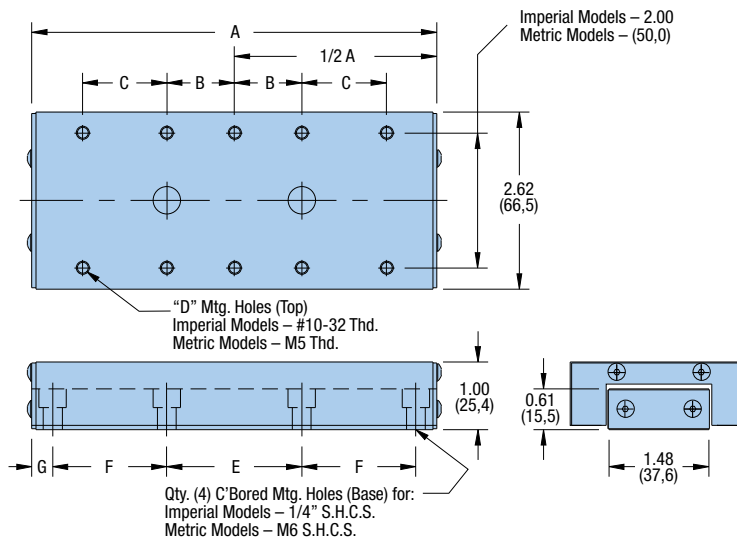

Model	Travel	Normal Load	Weight	Dimensions							
				A	B	C	D	E	F	G	
Imperial	4601	2.0 in	88 lbs	0.9 lbs	4.00 in	0.5 in	—	6	2.00 in	0.69 in	0.31 in
	4701	3.0 in	100 lbs	1.1 lbs	5.00 in	1.0 in	—	6	2.00 in	1.19 in	0.31 in
	4801	4.0 in	123 lbs	1.4 lbs	6.00 in	0.5 in	1.0 in	10	2.00 in	1.69 in	0.31 in
Metric	M4601	50,8 mm	40 kg	0,41 kg	101,6 mm	12,5 mm	—	6	50,0 mm	12,5 mm	13,3 mm
	M4701	76,2 mm	48 kg	0,50 kg	127,0 mm	25,0 mm	—	6	50,0 mm	25,0 mm	13,5 mm
	M4801	101,6 mm	56 kg	0,64 kg	152,4 mm	12,5 mm	25,0 mm	10	50,0 mm	25,0 mm	26,2 mm



**4600 Series**

**Specifications**

<b>Travel:</b>	6.0 – 30.0 in
<b>Size:</b>	
Width	2.62 in
Length	9.00 – 33.00 in
Height	1.00 in
<b>Load:</b>	
Normal	154 – 448 lbs
Moment: Yaw, Pitch, Roll	See page 32-33
<b>Straight line accuracy:</b>	0.00008 in/in of travel
<b>Weight:</b>	2.3 – 8.9 lbs
<b>Construction:</b>	Aluminum top and base/ 440C stainless steel bearings
<b>Mounting surface:</b>	Precision machined
<b>Finish:</b>	Black anodize



**Dimensions** in (mm)

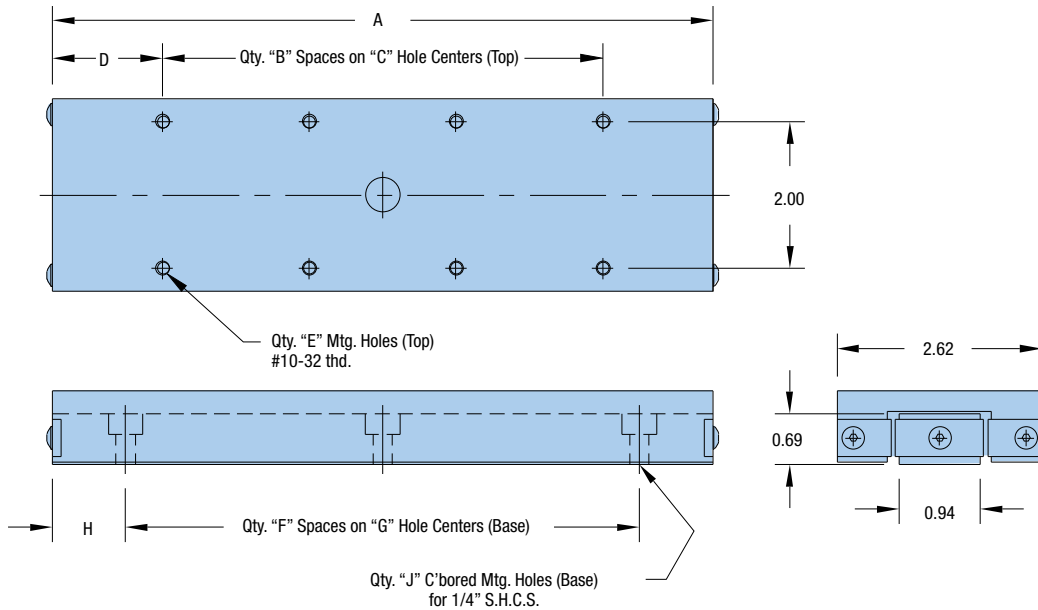

Model	Travel in	Normal Load lbs	Weight lbs	Dimensions – in									
				A	B	C	D	E	F	G	H	J	
4606	6.0	154	2.3	9.00	3	2.00	1.50	8	2	3.50	1.00	3	
4609	9.0	192	3.1	12.00	5	2.00	1.00	12	2	5.00	1.00	3	
4612	12.0	205	3.9	15.00	6	2.00	1.50	14	4	3.25	1.00	5	
4615	15.0	243	4.7	18.00	8	2.00	1.00	18	4	4.00	1.00	5	
4618	18.0	281	5.6	21.00	9	2.00	1.50	20	4	4.75	1.00	5	
4621	21.0	332	6.5	24.00	11	2.00	1.00	24	4	5.50	1.00	5	
4624	24.0	371	7.3	27.00	6	4.00	1.50	14	6	4.00	1.50	7	
4627	27.0	410	8.2	30.00	7	4.00	1.00	16	6	4.50	1.50	7	
4630	30.0	448	8.9	33.00	8	4.00	0.50	18	6	5.00	1.50	7	



**4400/M4400 Series**

Specifications	Imperial	Metric
Travel:	3.0 in	76,2 mm
<b>Size:</b>		
Width	5.00 in	127,0 mm
Length	5.00 in	127,0 mm
Height	1.00 in	25,4 mm
<b>Load:</b>		
Normal	106 lbs	48 kg
Moment: Yaw, Pitch, Roll	See page 31	See page 31
<b>Straight line accuracy:</b>	0.00008 in/in of travel	2 µm/25 mm of travel
<b>Weight:</b>	4410 – 2.2 lbs 4450 – 1.7 lbs	M4410 – 1,00 kg M4450 – 0,77 kg
<b>Construction:</b>	Aluminum top and base/ 440C stainless steel bearings	
<b>Mounting surface:</b>	Precision machined	
<b>Finish:</b>	Black anodize	

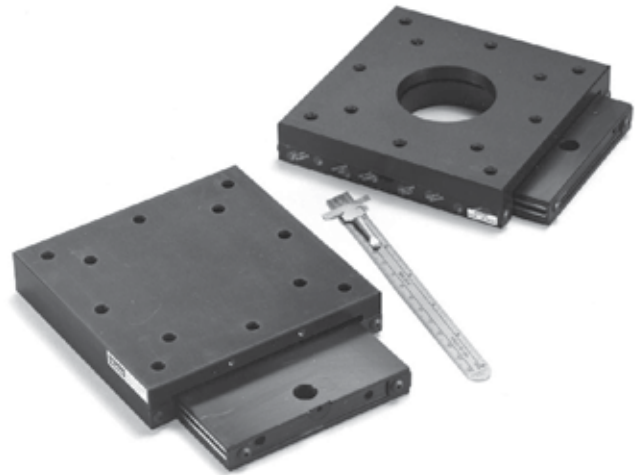

**Dimensions** in (mm)

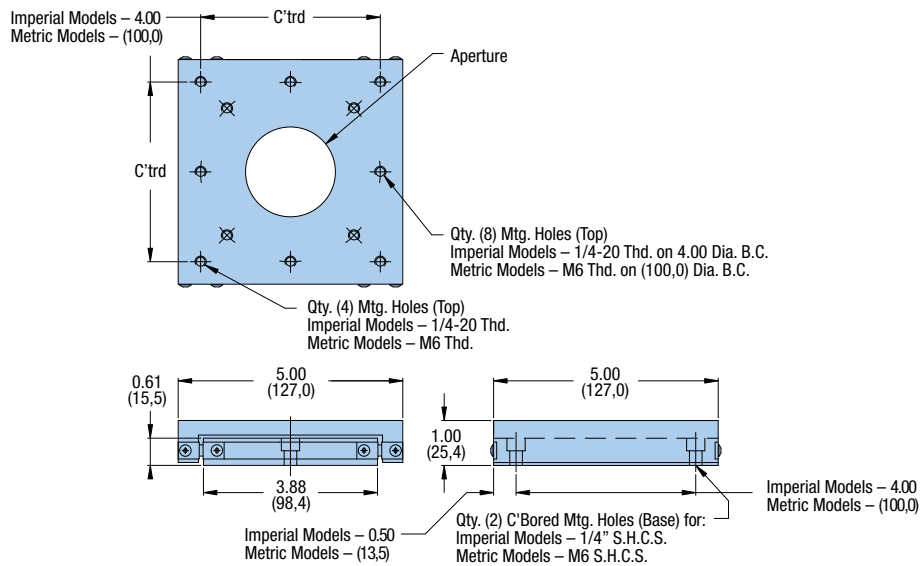

	Model	Travel	Aperture
Imperial	4410	3.0 in	—
	4450	3.0 in	2.00 in
Metric	M4410	76,2 mm	—
	M4450	76,2 mm	50,8 mm

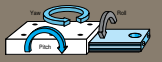

## Yaw, Pitch, Roll

Yaw & Pitch Roll

Moment Arm (mm) **3901/M3901 & 3905/M3905**

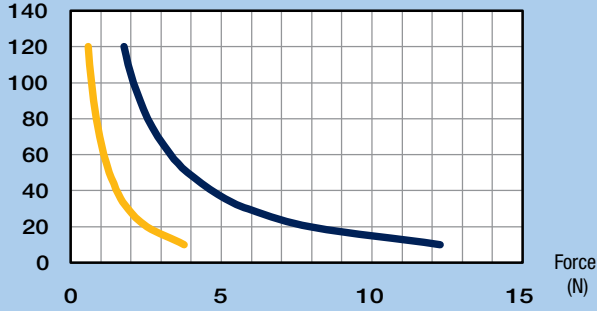

Moment Arm (mm) **4001/M4001 & 4005/M4005**

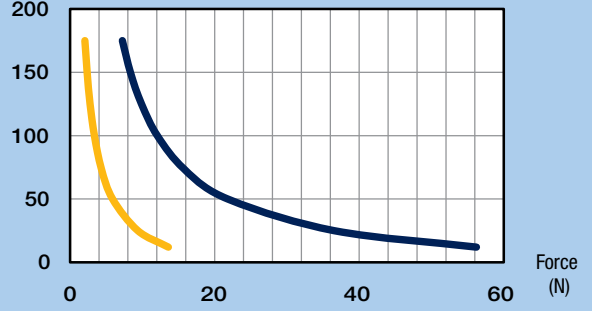

Moment Arm (mm) **4101/M4101 & 4005/M4005**

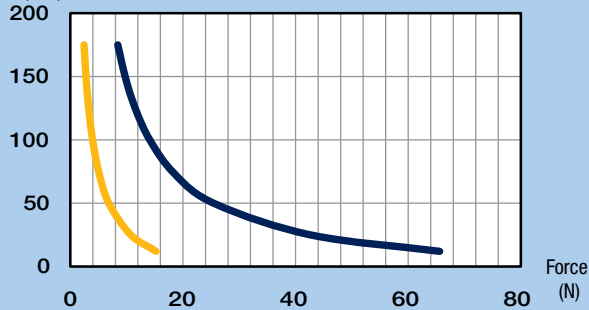

Moment Arm (mm) **4201/M4201**

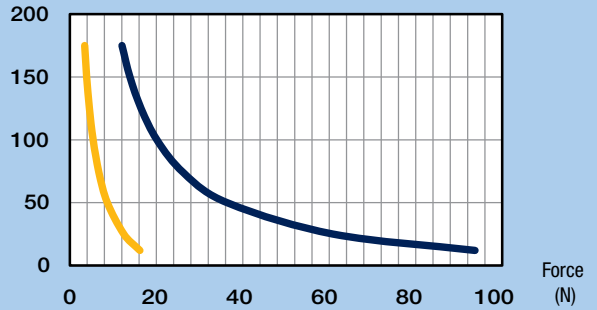

Moment Arm (mm) **4301/M4301**

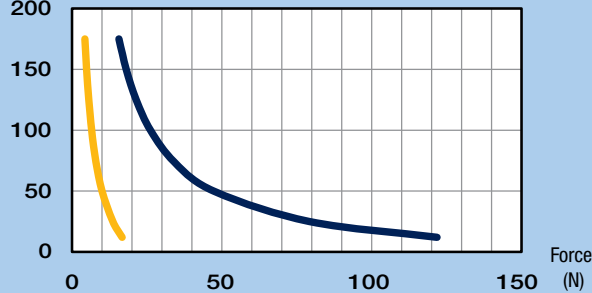

Moment Arm (mm) **4410/M4410 & 4450/M4450**

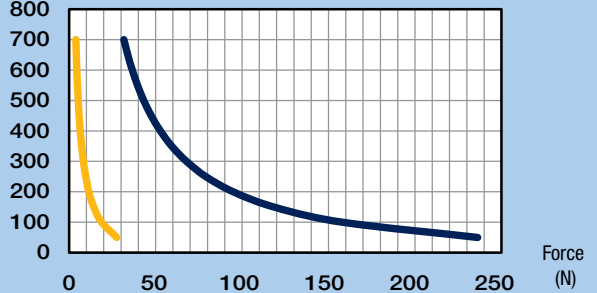

Moment Arm (mm) **4501/M4501 & 4505/M4505**

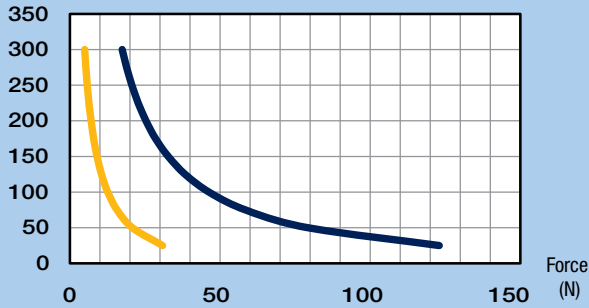

**Yaw, Pitch, Roll**

Yaw & Pitch   Roll

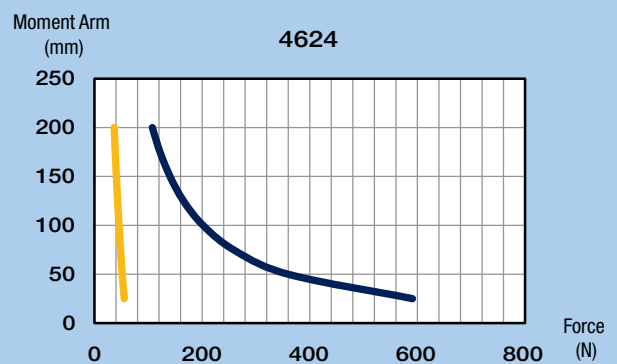
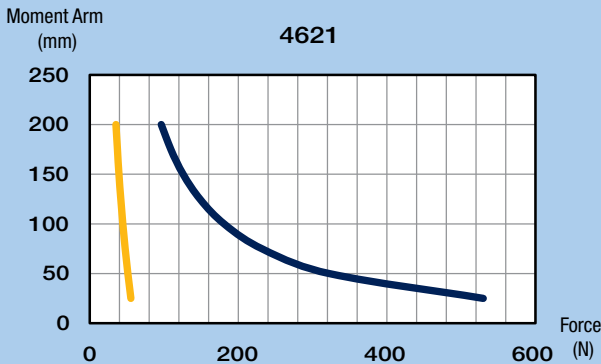
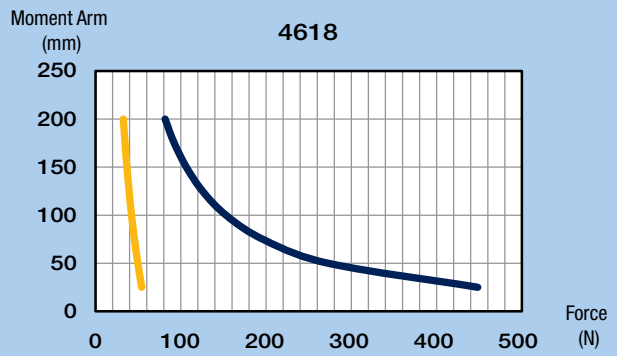
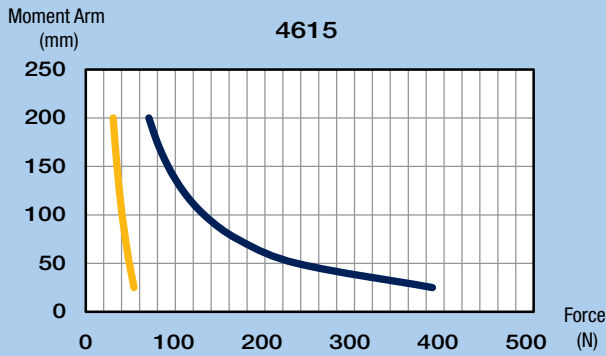
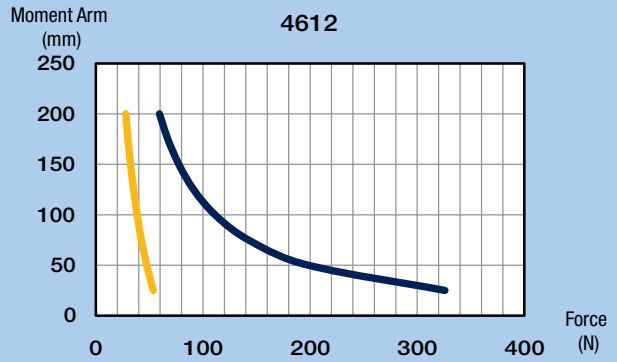
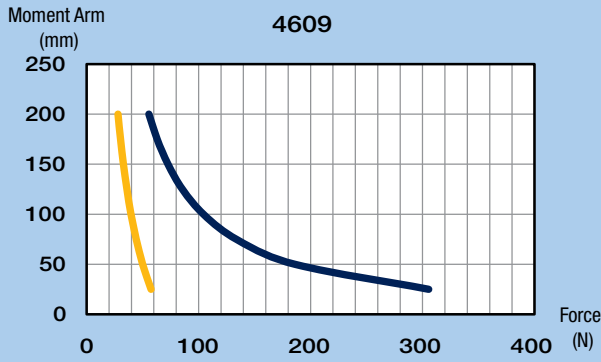
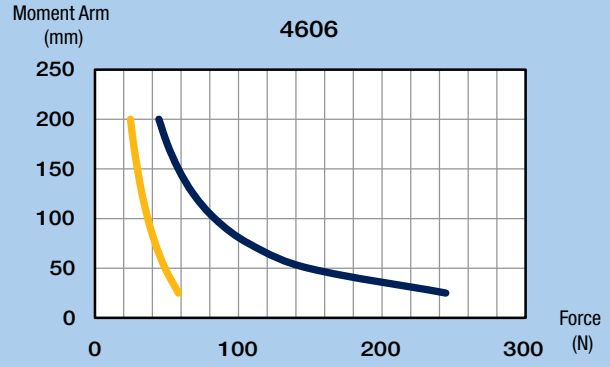
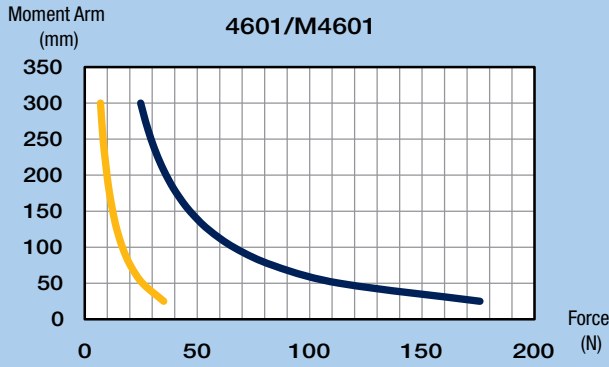

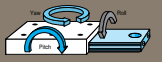

## Yaw, Pitch, Roll

Yaw & Pitch **Roll**

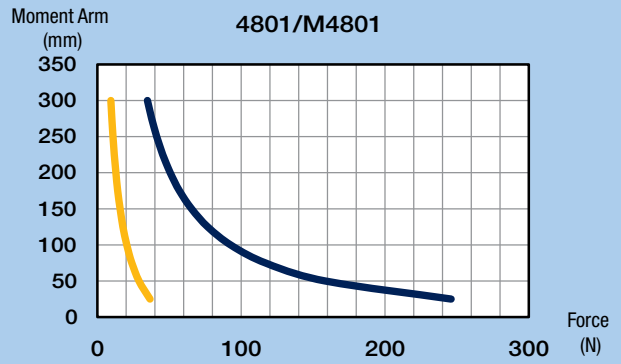
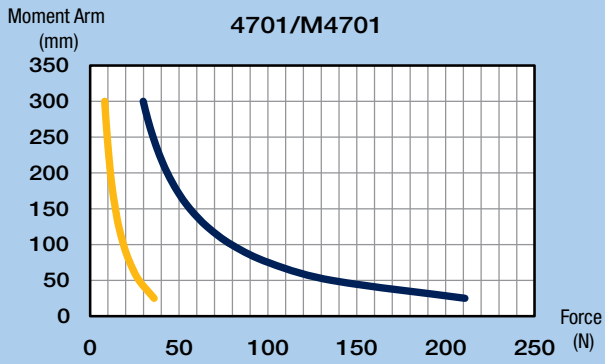
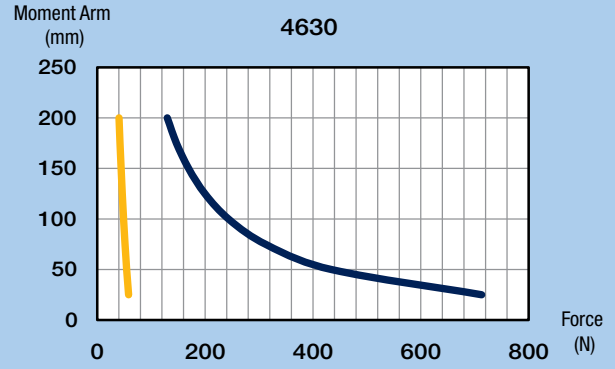
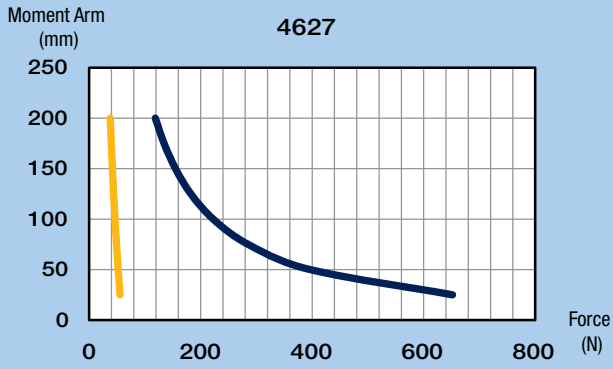

# Accessories for linear and rotary positioners



Parker Daedal offers a complete line of Z-axis brackets to combine ball bearing and cross roller stages into three axis positioning systems. We also offer drive mechanisms in an assortment of standard and digital micrometer heads, fine adjustment screws, and differential screws. Optical components including beam directors, optical mounts, mirror mounts and optical cells are also available.

## Contents

<b>124-127</b>	Z-Axis Brackets
<b>128-129</b>	Micrometer Heads
<b>130-132</b>	Optical Mounts

# Z-Axis Brackets

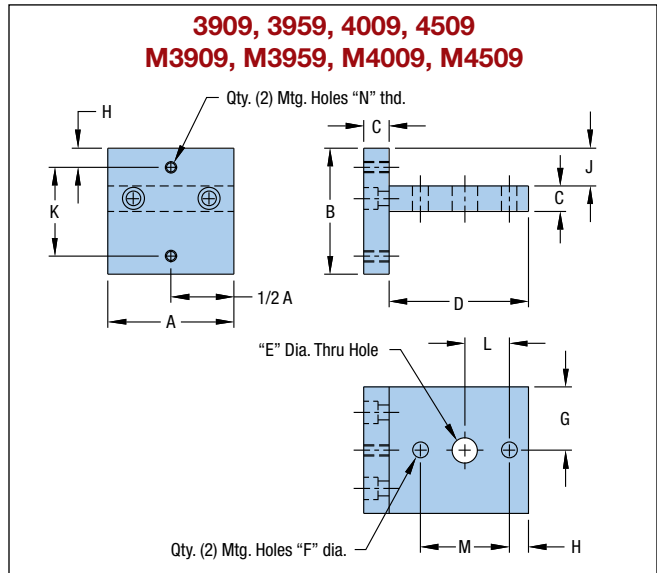

		Dimensions – in (mm)											Thd. N	
	Model	A	B	C	D	E	F	G	H	J	K	L	M	
Imperial	3909	1.25	1.25	0.25	1.38	0.25	0.156	0.62	0.19	0.38	0.88	0.44	0.88	#4-40
	3959	1.25	1.25	0.25	1.38	0.25	0.156	0.62	0.19	0.04	0.88	0.44	0.88	#4-40
	4009	1.75	1.69	0.25	1.88	—	0.156	0.88	0.31	0.63	1.12	—	1.12	#6-32
	4509	2.44	2.62	0.38	2.75	—	0.218	1.22	0.31	0.93	2.00	—	2.00	#10-32
Metric	M3909	(31,8)	(31,8)	(6,4)	(35,1)	(6,4)	(4,0)	(15,7)	(5,9)	(9,7)	(20,0)	(10,0)	(20,0)	M3
	M3959	(31,8)	(31,8)	(6,4)	(35,1)	(6,4)	(4,0)	(15,7)	(5,9)	(1,0)	(20,0)	(10,0)	(20,0)	M3
	M4009	(44,5)	(42,9)	(6,4)	(47,8)	—	(4,8)	(22,4)	(7,3)	(16,0)	(30,0)	—	(30,0)	M4
	M4509	(62,0)	(66,5)	(9,7)	(69,9)	—	(7,3)	(31,0)	(8,4)	(23,6)	(50,0)	—	(50,0)	M6

**3910, 3960  
M3910, M3960**

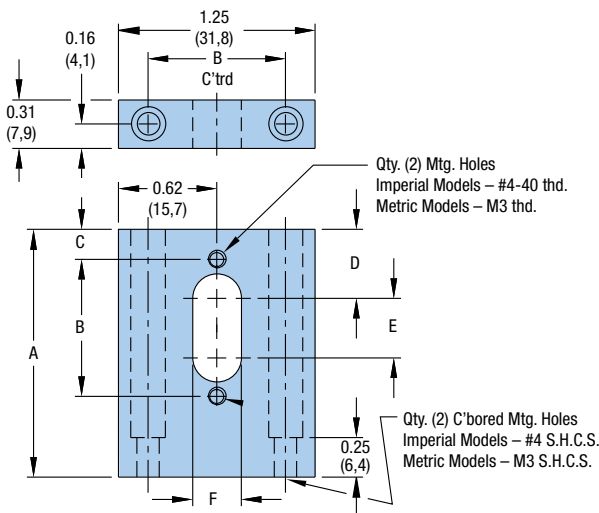

		Dimensions – in (mm)					
	Model	A	B	C	D	E	F
Imperial	3910	1.58	0.88	0.19	0.44	0.38	0.31
	3960	2.33	0.88	0.19	0.44	0.38	0.31
Metric	M3910	(40,1)	(20,0)	(5,9)	(12,3)	(7,1)	(6,4)
	M3960	(59,2)	(20,0)	(5,9)	(12,3)	(7,1)	(6,4)

**4010, 4020  
M4010, M4020**

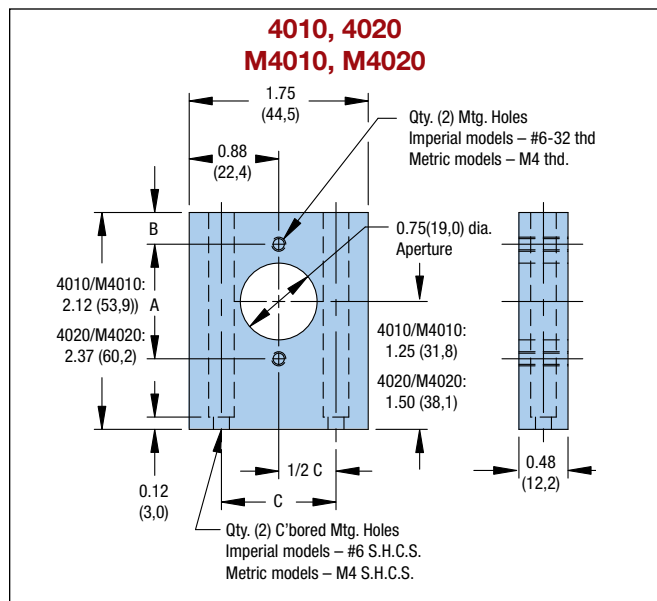

		Dimensions – in (mm)		
	Model	A	B	C
Imperial	4010	1.12	0.31	1.12
Metric	M4010	(30,0)	(7,1)	(30,0)



## 4059 M4059

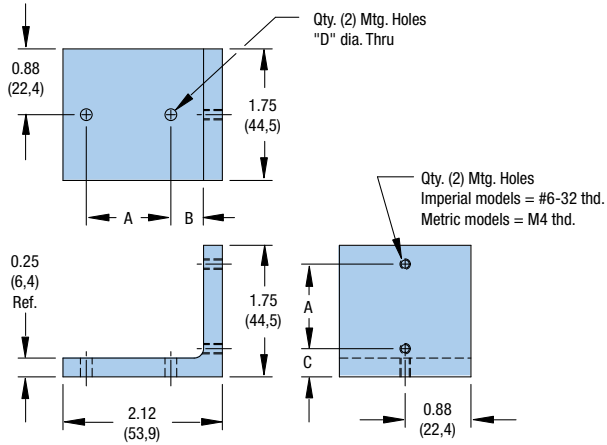

## 4059A M4059A

For 1.00 inch (25,0 mm) Travel Micrometer Option

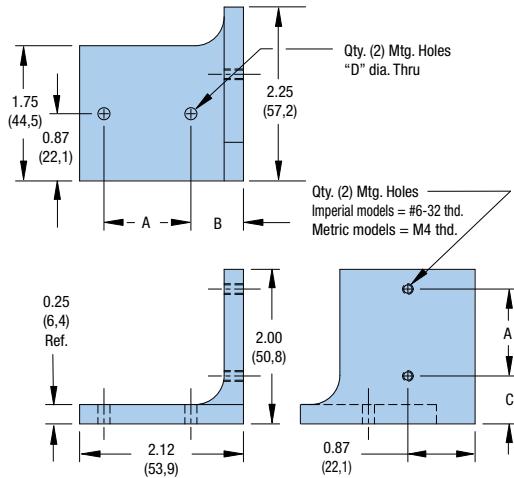

Dimensions - in (mm)

	Model	A	B	C	D
Imperial	4059	1.12	0.68	0.38	0.16
Metric	M4059	(30,0)	(16,8)	(8,8)	(4,8)

Dimensions - in (mm)

	Model	A	B	C	D
Imperial	4059A	1.12	0.68	0.62	0.16
Metric	M4059A	(30,0)	(16,8)	(15,2)	(4,8)

## 4060 M4060

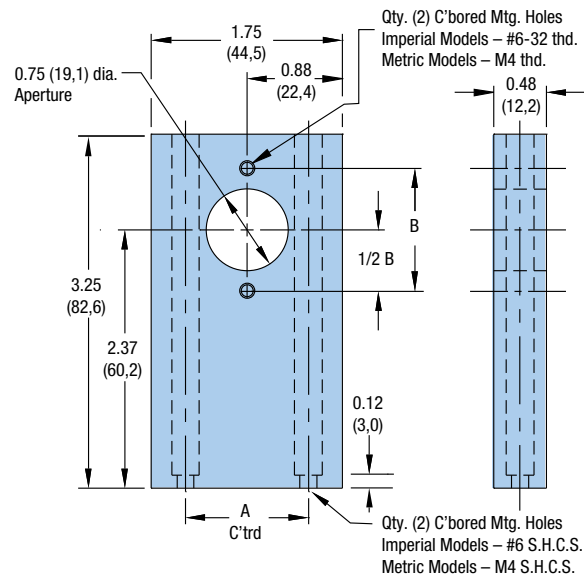

Dimensions - in (mm)

	Model	A	B
Imperial	4060	1.13	1.13
Metric	M4060	(30,0)	(30,0)

## 4510 M4510

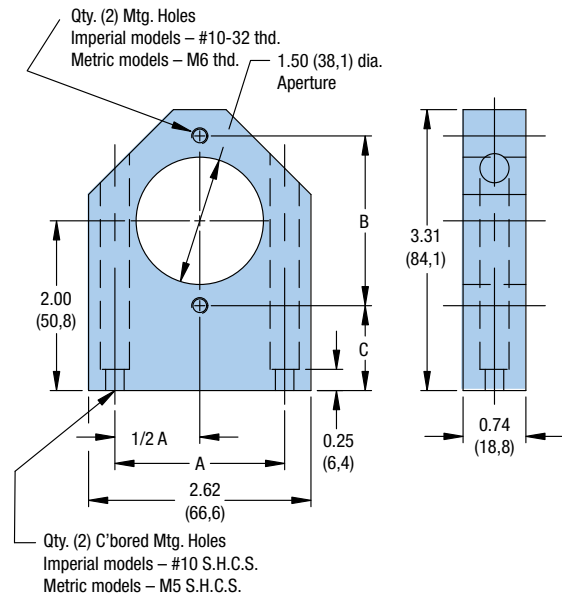

Dimensions - in (mm)

	Model	A	B	C
Imperial	4510	2.00	2.00	1.00
Metric	M4510	(50,0)	(50,0)	(25,8)

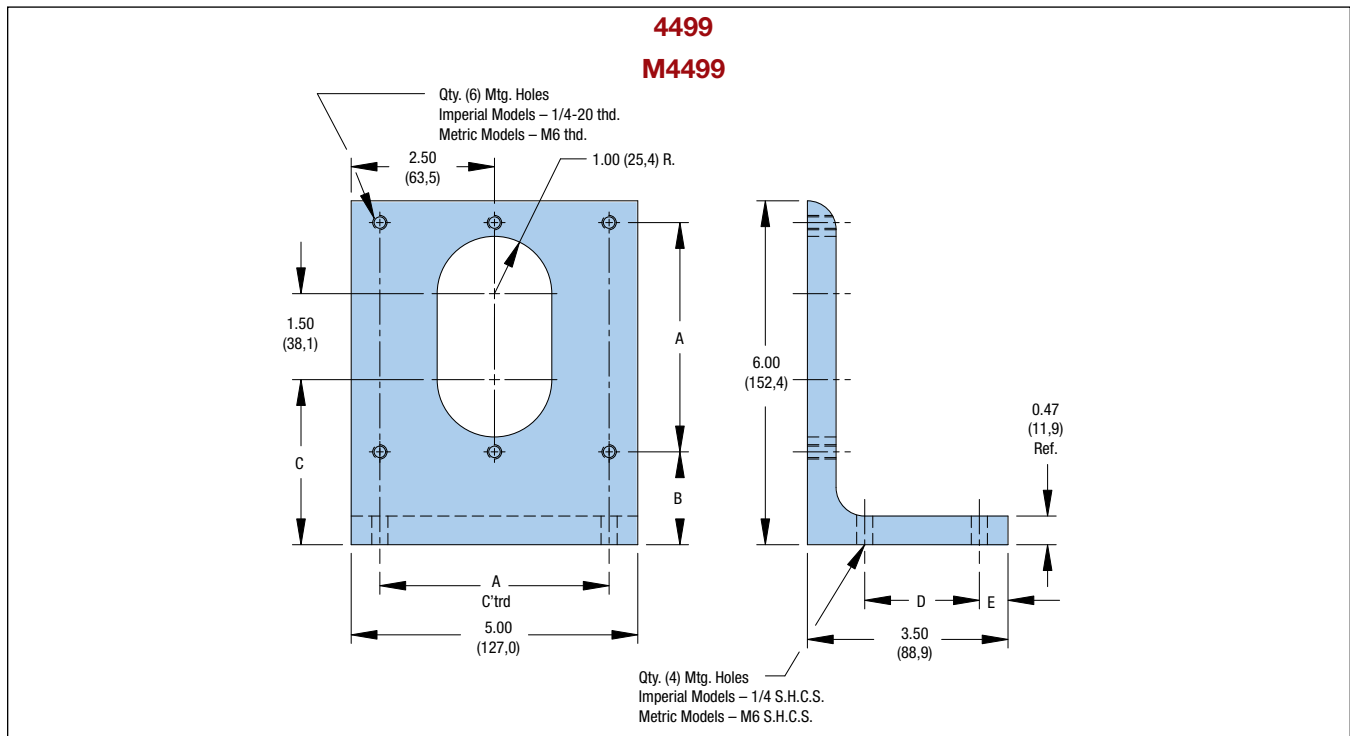

Dimensions – in (mm)						
	Model	A	B	C	D	E
Imperial	<b>4499</b>	4.00	1.62	2.88	2.00	0.50
Metric	<b>M4499</b>	(100,0)	(40,5)	(71,4)	(50,0)	(13,1)

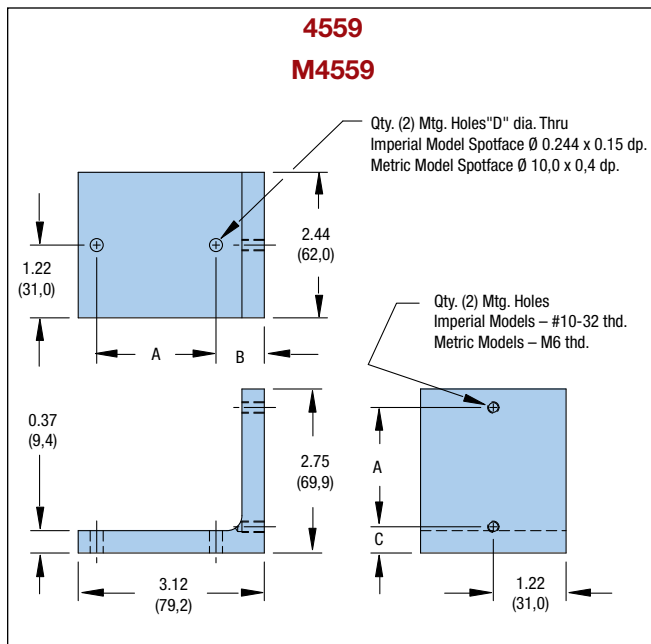

Dimensions – in (mm)					
	Model	A	B	C	D
Imperial	<b>4559</b>	2.00	0.81	0.44	0.22
Metric	<b>M4559</b>	(50,0)	(20,9)	(11,5)	(5,5)

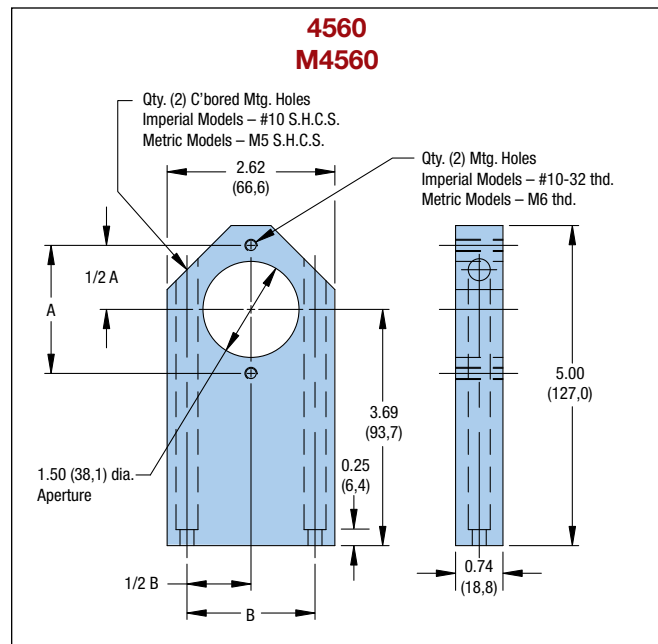

Dimensions – in (mm)			
	Model	A	B
Imperial	<b>4560</b>	2.00	2.00
Metric	<b>M4560</b>	(50,0)	(50,0)



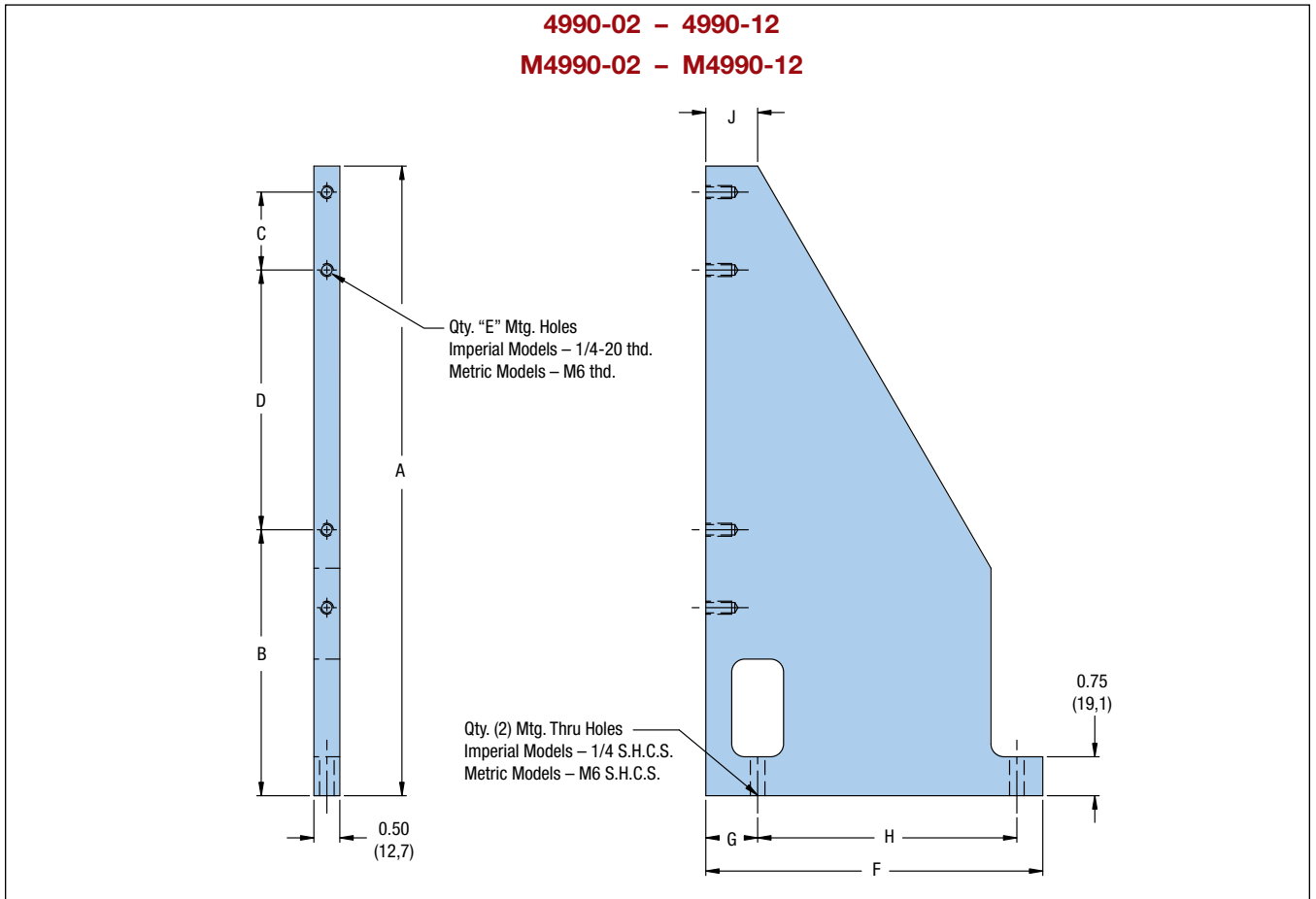

		Dimensions – in (mm)									
	Model	A	B	C	D	E	F	G	H	J	
<b>Imperial</b>	<b>4990-02</b>	6.00	1.50	–	4.00	2	5.50	1.00	4.00	1.00	
	<b>4990-04</b>	8.12	2.62	–	5.00	2	6.50	1.00	5.00	1.00	
	<b>4990-06</b>	12.12	5.12	1.5	5.00	4	6.50	1.00	5.00	1.00	
	<b>4990-08</b>	17.12	8.62	3.0	5.00	4	6.75	1.25	5.00	1.50	
	<b>4990-10</b>	20.50	10.00	4.0	6.00	4	6.75	1.25	5.00	1.50	
	<b>4990-12</b>	24.12	11.62	5.0	7.00	4	6.50	1.00	5.00	1.00	
<b>Metric</b>	<b>M4990-02</b>	(152,4)	(38,9)	–	(100,0)	2	(139,7)	(26,2)	(100,0)	(25,4)	
	<b>M4990-04</b>	(206,2)	(67,6)	–	(125,0)	2	(165,1)	(26,4)	(125,0)	(25,4)	
	<b>M4990-06</b>	(307,8)	(131,2)	(37,5)	(125,0)	4	(165,1)	(26,4)	(125,0)	(25,4)	
	<b>M4990-08</b>	(434,8)	(220,0)	(75,0)	(125,0)	4	(171,5)	(32,8)	(125,0)	(38,1)	
	<b>M4990-10</b>	(520,7)	(255,2)	(100,0)	(150,0)	4	(171,5)	(32,8)	(125,0)	(38,1)	
	<b>M4990-12</b>	(612,6)	(296,6)	(125,0)	(175,0)	4	(171,5)	(32,8)	(125,0)	(38,1)	

**Accessories**

**9510-9530 Series Micrometer Heads**

Parker Daedal micrometer heads are recommended for any application requiring micrometer accuracy in settings and adjustment. These units feature a hardened and ground spindle, easy-to-read graduations, and an attractive non-glare satin chrome finish.

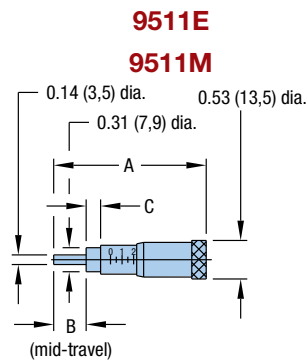

**Figure A**  
Mini Thimble Micrometer Head

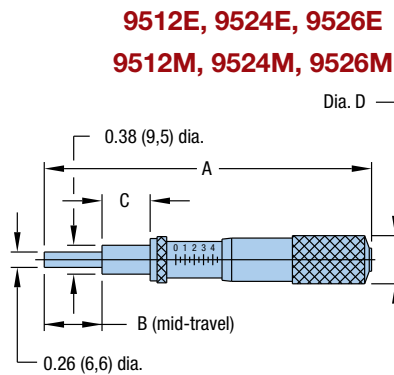

**Figure B**  
Standard Thimble Micrometer Head

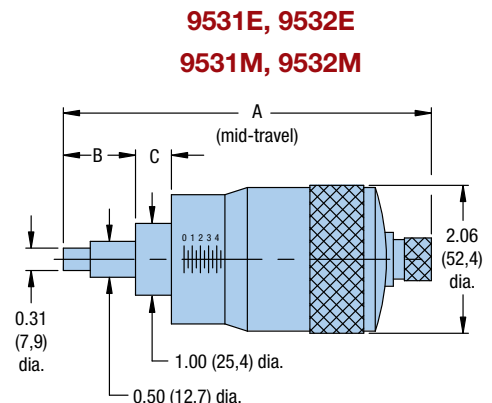

**Figure C**  
Large Thimble Micrometer Head

		Model Number	Figure	Travel in (mm)	Graduations in (mm)	Dimensions – in (mm)			
						A	B	C	D
Imperial		9511E	A	0.50	0.001	2.03	0.50	0.187	—
		9512E	B	0.50	0.001	2.63	0.50	0.375	0.54
		9524E	B	1.00	0.001	4,23	0.75	0.625	0.73
		9526E	B	2.00	0.001	6.16	1.25	0.625	0.73
		9531E	C	1.00	0.0001	5.18	0.94	0.56	—
		9532E	C	2.00	0.0001	7.18	1.44	0.56	—
Metric		9511M	A	(13)	(0,01)	(51,6)	(13,0)	(4,7)	—
		9512M	B	(13)	(0,01)	(66,8)	(13,0)	(9,5)	(13,7)
		9524M	B	(25)	(0,01)	(107,4)	(19,0)	(15,9)	(18,5)
		9526M	B	(50)	(0,01)	(156,5)	(32,0)	(15,9)	(18,5)
		9531M	C	(25)	(0,002)	(131,6)	(23,9)	(14,2)	—
		9532M	C	(50)	(0,002)	(182,4)	(36,6)	(14,2)	—

**9550 Series Digital Micrometer Heads**

**Model 9551**

The 9551 precision electronic digital micrometer head provides an LCD readout to 0.00005 inch resolution. The micrometer features:

- Incremental and/or absolute positioning modes
- Zero set at any position, inch and millimeter readout (0.001 mm resolution), display hold, and automatic shutdown after two hours to conserve the integral battery
- 1.00 inch micrometer travel
- Battery powered for 500 hours of use

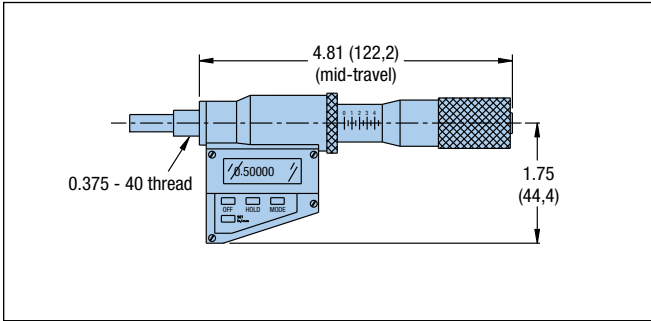

**Model 9552**

The 9552 precision electronic digital micrometer offers a 0 – 2 inch travel range with a 0.00005 inch resolution. Features include:

- 2 inch spindle
- Display face swivels for easy reading at various angles
- Non-rotating spindle
- Pre-set, zero, and inch/mm
- Carbide tipped measuring face
- Battery powered for 5,000 hours of use

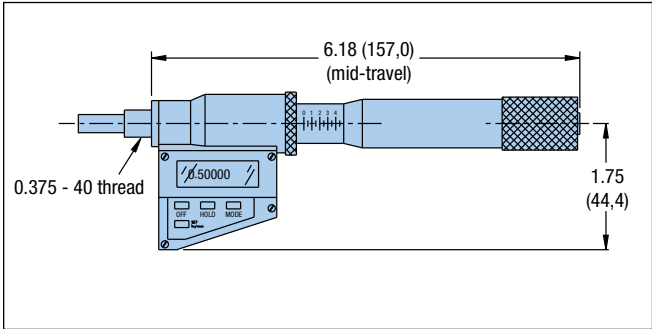

**9560 Series Differential Screws**

**Model 9560: 0.75 in Range**

The 9560 differential screw offers two linear adjustment ranges in one unit: a coarse adjustment range of 0.31 in (8 mm) with a 48-pitch thread and a fine adjustment range of 0.078 in (2 mm) with a pitch equal to 336 threads per inch. The 9560 is interchangeable with 9511 – 9532 series micrometer heads.

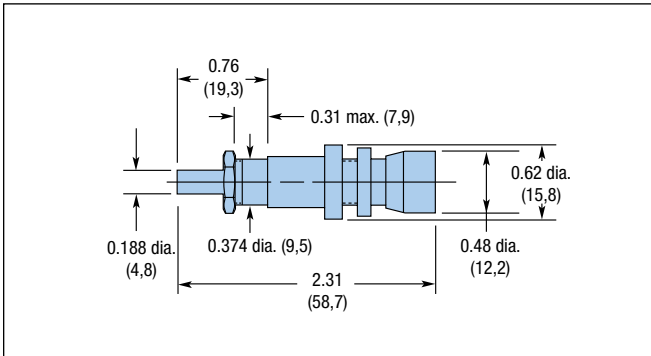

**9570 Series Fine Adjustment Screws**

**Model 9570: 0.75 in Range**

**Model 9575: 0.50 in Range**

These steel adjustment screws feature a 64-pitch thread, making them ideal for applications where finer resolution is required, but positional readout is not. These screws are easily interchanged with the 9511 – 9532 series micrometer heads.

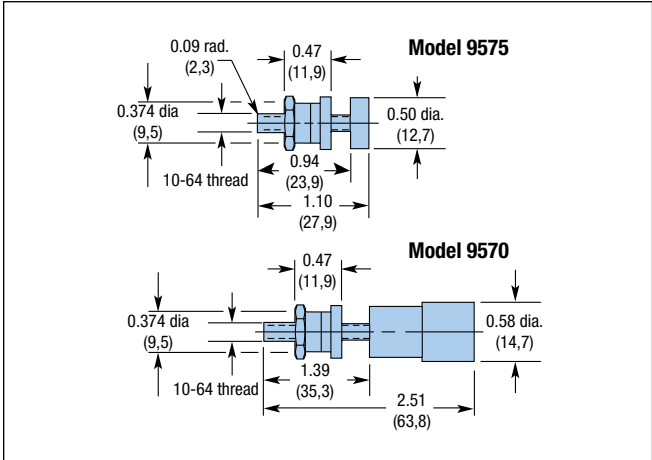

Accessories

**Optical Cell Mounts**

**Model 2350: 6.0” Diameter**

**Model 2355: 7.0” Diameter**

**Model 2360: 8.0” Diameter**

**Model 2365: 9.0” Diameter**

Parker Daedal optical mounts are highly stable, adjustable mounts for optics up to 9” in diameter and 1.25” thick. These mounts feature precise kinematic ball pivot adjustment on two axes, with orthogonal three-point suspension.

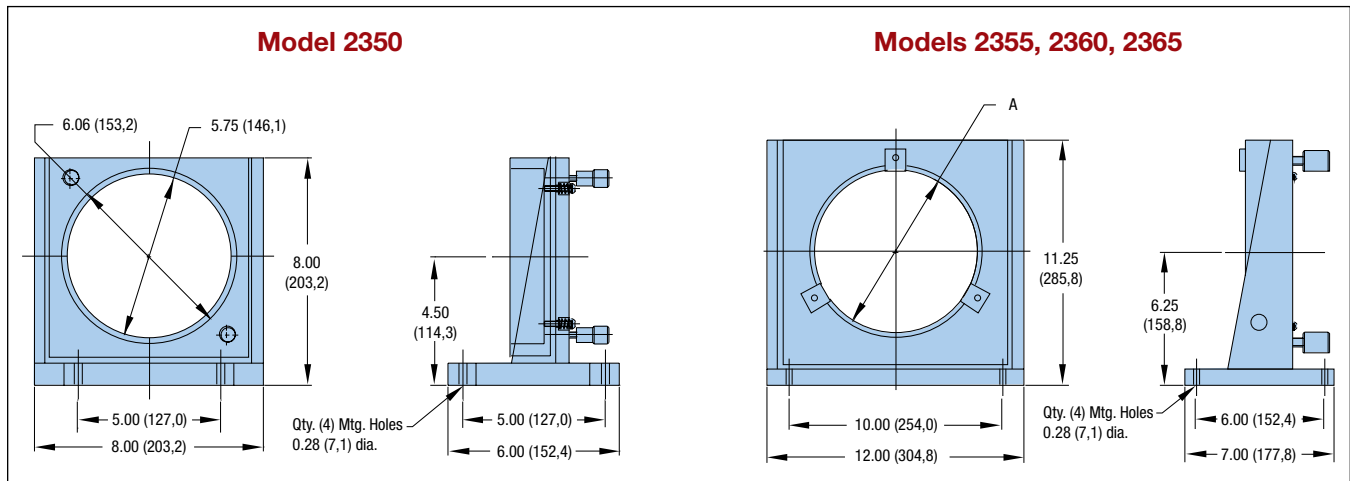

Specifications	2350	2355	2360	2365
Optic Size Opening – in (mm)				
Dimension “A” Dia. max.:	6.03 (153,1)	7.06 (179,3)	8.06 (204,7)	9.06 (230,1)
Thickness:	1.00 (25,4)	1.25 (31,75)	1.25 (31,7)	1.25 (31,7)
Optic Retention:	Threaded retainer	3 mounting clips	3 mounting clips	3 mounting clips
Range:	5°	5°	5°	5°
Resolution:	0.5 arc-sec	0.5 arc-sec	0.5 arc-sec	0.5 arc-sec
Adjustment:	2 – 64-pitch screws	3 – 32-pitch screws	3 – 32-pitch screws	3 – 32-pitch screws
Weight:	7.5 lb (16,5 kg)	20 lb (44 kg)	20 lb (44 kg)	20 lb (44 kg)
Construction:	Aluminum/stainless steel			
Finish:	Black anodize			



## Optical Cell Mounts

**Model 2370/2371: 10.0" Diameter**

**Model 2375/2376: 11.0" Diameter**

**Model 2380/2381: 12.0" Diameter**

Parker Daedal optical mounts are highly stable, adjustable mounts for optics up to 12" in diameter and 2.0" thick. These mounts feature precise kinematic ball pivot adjustment on two axes, with orthogonal three-point suspension. Solid back models are designed to support reflective optics.

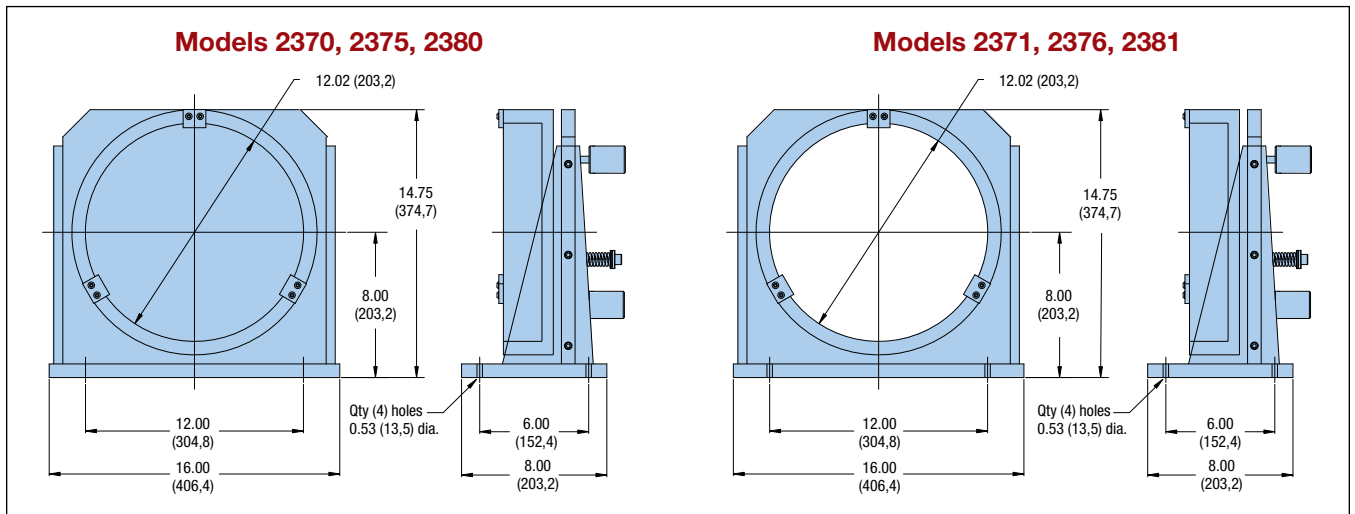
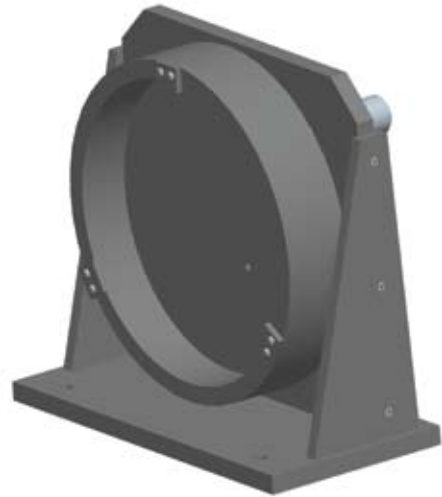

Specifications	Solid Back Models			Aperture Models		
	2370	2375	2380	2371	2376	2381
<b>Optic Size Opening – in (mm)</b>						
Dimension "A" Dia. max.:	10.02 (254,5)	11.02 (379,9)	12.02 (305,3)	10.06 (255,5)	11.06 (280,9)	12.06 (306,3)
Thickness:	2.00 (50,8)	2.00 (50,8)	2.00 (50,8)	2.00 (50,8)	2.00 (50,8)	2.00 (50,8)
<b>Optic Retention:</b>	3 mounting clips			3 mounting clips		
<b>Range:</b>	7°			7°		
<b>Resolution:</b>	0.5 arc-sec			0.5 arc-sec		
<b>Adjustment:</b>	3 – 32-pitch screws			3 – 32-pitch screws		
<b>Weight:</b>	45 lb (99 kg)			41 lb (90 kg)		
<b>Construction:</b>	Aluminum/stainless steel			Aluminum/stainless steel		
<b>Finish:</b>	Black anodize			Black anodize		

**Mirror Mounts**

**Model 5000/5100: 3.0" Square Mounting Surface**

**Model 5300/5700: 4.5" Square Mounting Surface**

**Model 5800/5900: 6.0" Square Mounting Surface**

Parker Daedal mirror mounts are patterned with 1/4-20 holes on 0.5" or 1.0" centers to mount mirrors and other hardware. All models except the 5800 have two fine resolution 64-pitch adjustment screws to provide precise tilting of the mounting surface in two axes. The 5800 is equipped with three adjustment screws to provide precise tilting in two axes.

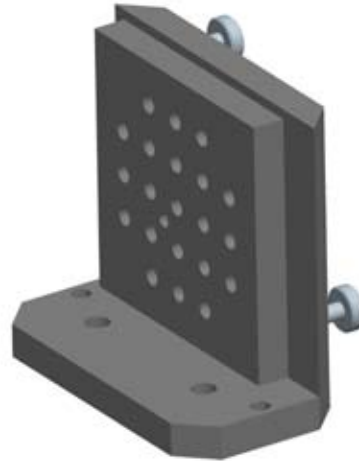

Specifications	Angled Base Models			Flat Base Models		
	5000	5300	5800	5100	5700	5900
<b>Mounting Surface</b>						
Size (Square) – in (mm)	3.0 (76,2)	4.5 (114,3)	6.0 (152,4)	3.0 (76,2)	4.5 (114,3)	6.0 (152,4)
Holes – (Qty. x Center)	21 x 0.50"	49 x 0.50"	25 x 1.0"	21 x 0.50"	49 x 0.50"	25 x 1.0"
<b>Range:</b>	12°	8°	4°	12°	8°	4°
<b>Resolution:</b>	1.0 arc-sec	0.75 arc-sec	0.5 arc-sec	1.0 arc-sec	0.75 arc-sec	0.5 arc-sec
<b>Weight – lb (kg)</b>	1 (2,2)	2 (4,4)	4.1 (9)	0.7 (1,5)	1.6 (3,5)	3 (6,6)
<b>Adjustment:</b>	2 – 64-pitch screws (3 screws on 5800)			2 – 64-pitch screws		
<b>Construction:</b>	Aluminum/stainless steel			Aluminum/stainless steel		
<b>Finish:</b>	Black anodize			Black anodize		

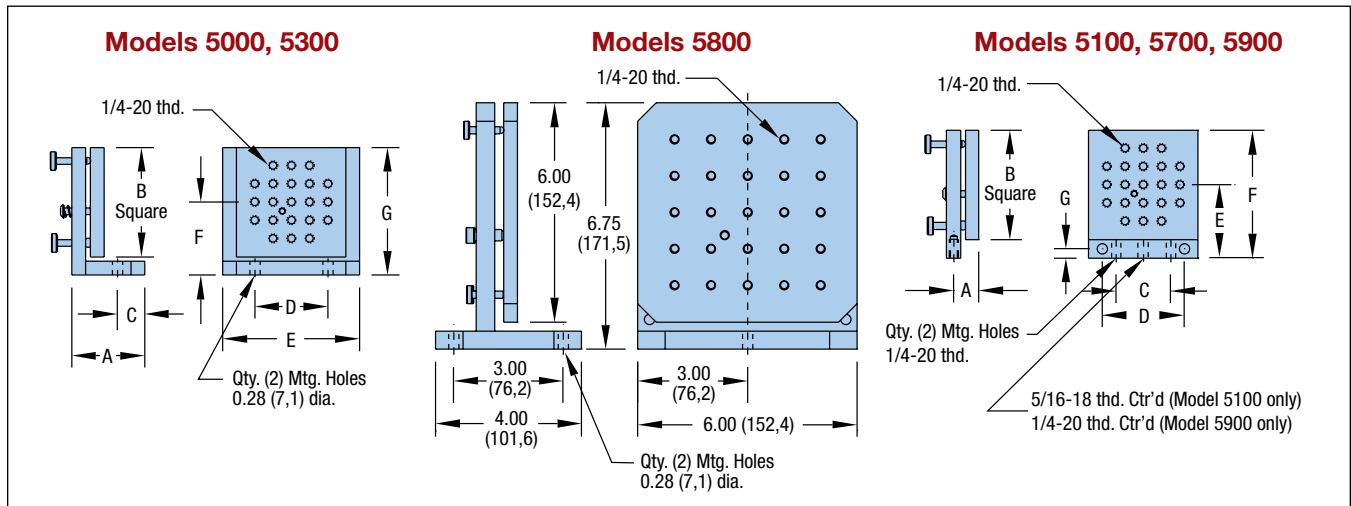

Model	Dimensions – in (mm)						
	A	B	D	D	E	F	G
5000	2.00 (50,8)	3.00 (76,2)	0.75 (19,1)	2.00 (50,8)	3.75 (95,3)	2.00 (50,8)	3.50 (88,9)
5300	3.00 (76,2)	4.50 (114,3)	1.25 (31,8)	4.00 (101,6)	4.50 (114,3)	2.88 (73,2)	5.12 (130,1)
5100	0.69 (17,5)	3.00 (76,2)	1.50 (38,1)	2.25 (57,2)	2.00 (50,8)	3.50 (88,9)	0.25 (6,4)
5700	0.69 (17,5)	4.50 (114,3)	3.00 (76,2)	3.75 (95,3)	2.88 (73,2)	5.12 (130,1)	0.25 (6,4)
5900	0.88 (2,4)	6.00 (152,4)	4.00 (101,6)	5.38 (136,7)	3.25 (82,6)	6.25 (158,8)	0.31 (7,9)

## Travel

The travel listed is the total travel of the positioner from hard stop to hard stop.

## Bearing Load Capacity

### Normal Load

This is the maximum downward (compression) load or force which can be applied to the positioner perpendicular to the mounting surface. The center of force or the C.G. of the load must be located in the center of the mounting surface. For loads which are offset from this position, refer to moment loads.

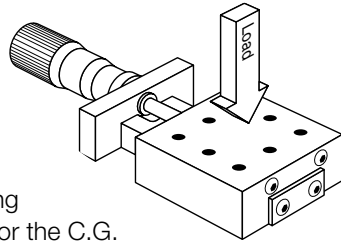

### Inverted Load

Same as a normal load except in an upward (tension) direction.

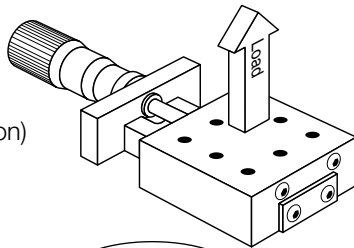

### Moment Load

This refers to forces which are offset (cantilevered) from the bearing centers and therefore producing uneven loading on the bearings. This uneven loading means that some bearings are supporting more of the load than others. For this reason it is very important to determine if the moment loading for a given positioner is within acceptable limits. These moment forces are categorized by the direction they act in Pitch, Roll or Yaw; see diagram at left. When loading results in moments acting in only one of the moment directions (pitch, roll or yaw) it is called a single direction moment. Examples of this type of loading are shown below. How to calculate the maximum allowable moment load is discussed on the following page.

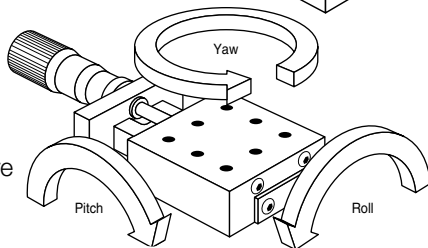

## Thrust Capacity

Thrust capacity is the maximum force or load which can be applied in the direction of travel without damage to positioning stage components.

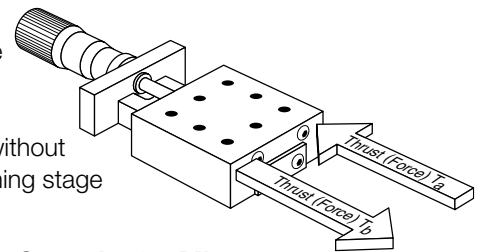

### T<sub>a</sub> and T<sub>b</sub> Thrust Capacity for Micrometer, Fine Screw and Differential Screw Drives

With these types of drives the mounting surface or stage carriage is pressed against the drive mechanism by means of a spring. Because of this the maximum thrust which the stage assembly can maintain is different when pressing toward the spring or away from it. When pressing toward the spring, the force is taken up by the drive mechanism (i.e. micrometer). While pulling away, the force is being held in place by the spring. Stages with this type of mechanism have two thrust capacity specifications (T<sub>a</sub> and T<sub>b</sub>). T<sub>a</sub> refers to the load capacity against the micrometer and T<sub>b</sub> is the spring load capacity. Refer to specific product drawings for load direction.

### Screw Drive Thrust Capacity

Stages which use screw drive assemblies will only have one thrust capacity rating. This rating is for either direction of travel.

## Straight Line and Flatness Accuracy

This is the amount of error a linear positioner deviates from an ideal straight line. The straight line accuracy is the error in the horizontal plane while flatness is the error in the vertical plane. Both the straight line and the flatness accuracy are measured at the moving carriage surface center.

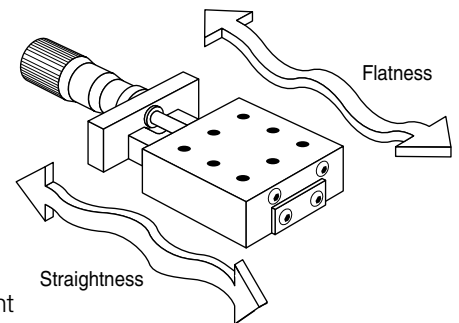

Pitch Moment

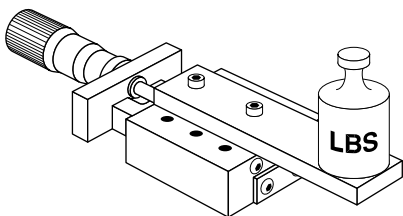

Roll Moment

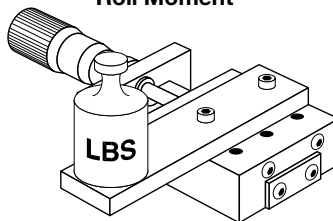

Compound Pitch/Roll Moment

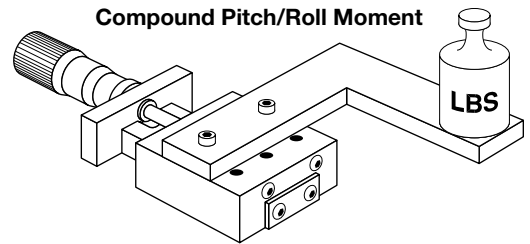

### Calculating Maximum Allowable Moment Loads on Linear Slides and Stages

To determine if a load or force is within acceptable moment load ranges follow the steps below:

1. Calculate maximum load and or force which will be applied to the positioner. Include brackets and other axes which are mounted to the positioner.
2. Locate the center of gravity of the load.
3. Determine if there is a single or compound moment.
4. Measure the distance from the center of force or C.G. to the center of the linear stage carriage. This is the moment arm length and is designated  $A_S$  for single direction moments and  $A_C$  for compound moments.
5. Locate the moment load graph for the positioner you are interested in (located in back of individual product section, see example below). The X axis of the graph is the Force, the Y axis is the allowable moment arm  $A_S$  for single direction moments.
6. Locate the moment curve(s) which your load is acting in (pitch, roll or yaw).
7. Locate your load force on the X axis of the graph.
8. Draw a vertical line from the Force location on the X axis parallel with the Y axis.
9. Find the moment arm distance on the Y axis. Draw a horizontal line from this point parallel with the X axis until the vertical and horizontal lines intersect.
10. If the intersection point is below the moment curve in question then the stage is within acceptable limits. If the intersection point is above the moment curve, a positioner with a larger normal load capacity should be selected and the above steps repeated.

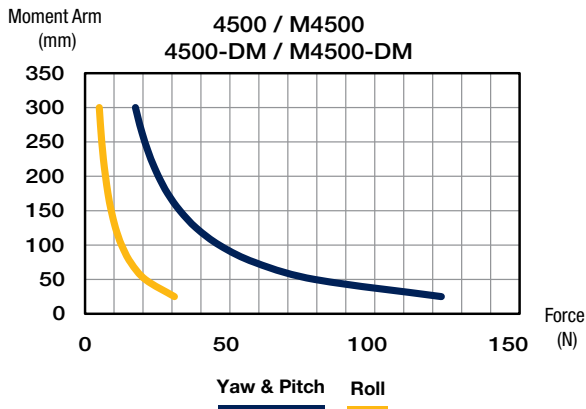

#### Example #1: Single Direction Moment Load

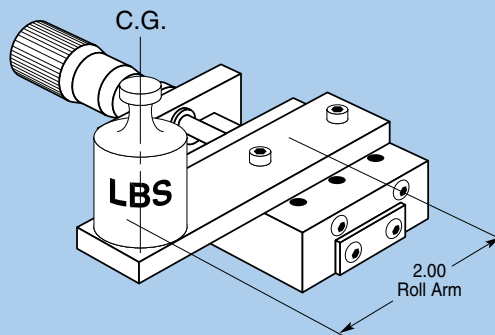

A 2 pound load is mounted to a single axis linear stage. The diagram shows the load's position in reference to the positioner carriage center. This shows that the load is offset 2 inches from the carriage center creating a roll moment.

The selected positioner is a 4502 ball stage. (The moment load curve for the 4502 is shown below.) First, find 2 pounds on the X axis and draw a vertical line. Next, draw a horizontal line starting at the 2 inches position on the  $A_S$  axis (single direction moment). Mark the intersection point.

In this example the intersection point is below the roll moment curve, indicating that the stage is acceptable for this application.

