

ERV Series Rodless Actuators



ERV Series

Contents

Overview.....	54
Specifications	55
Technical Data	
ERV5 Loading	56
ERV8 Loading	57
Deflection	58
Effective Belt Pull	58
Dimensions.....	59
Options	
Carriage Length	60
Spliced Units	60
Bumpers.....	60
Felt Wiper	61
Mounting Options	62
Sensors	63
Ordering Information.....	64
Application Fax Form.....	66

Parker Hannifin Corporation
Actuator Division
Wadsworth, Ohio USA
Phone: 1-866-PARK-ACT
email: actuatorsales@parker.com
website: www.parker.com/actuator

The ERV Series

Expanding on the ER, the ERV was designed with an external carriage containing outboard roller bearing support for higher loads. The actuator is designed to directly interface with our structural framing, providing a simple and cost effective solution for single or multiple-axis systems.

The ERV design means

- High loading to 3590 N
- High speeds to 5m/sec
- High thrust to 808 N
- Multi-axis connectivity for Gantry systems
- Strokes to 6 meters for single extrusion, spliced units for longer strokes.
- Internal belt drive
- Extrusion body cylinder with additional center web for rigidity and axial stiffness.

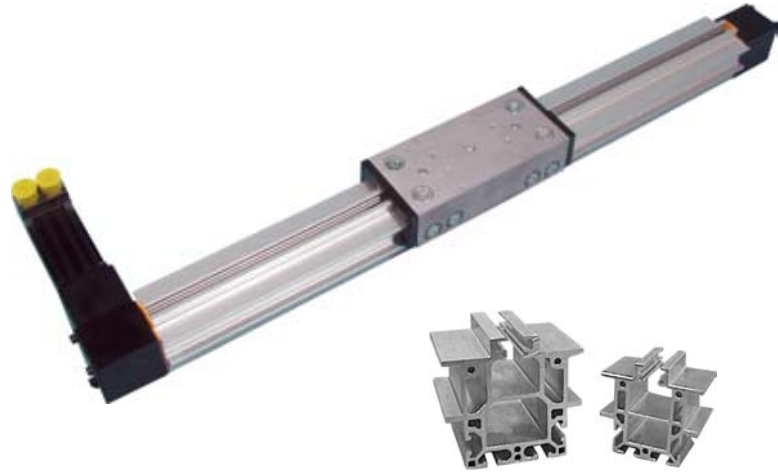

The ERV multiple design options can be matched to your application demands.

- 2 profile sizes (56 and 80mm)
- Polyurethane steel reinforced drive belt
- Standard and extended carriages for high loads
- Ready to mount stepper or brushless servo motors.

ERV Markets and Applications

With thousands of axes installed worldwide, the ERV series rodless actuator has proven to be a robust and reliable solution for numerous motion control applications across many markets and industries. Listed below are some examples of where and how the ERV series rodless actuator has been successfully applied.

Markets and Industries Served

Automotive	Life Sciences	Machine Tool
Tire & Rubber	Medical	Wood & Lumber
Packaging	Conveyor	Research & Testing
Food & Beverage	Transportation	Aerospace
Computer / Electronics	Pharmaceutical	Glass / Fiber
Textile	Semiconductor	Factory Automation

Application Examples

Discrete / Multi-Point Positioning	Small Area Gantry	Large Area Gantry	Complex Motion Control
Vertical Stackers / Elevator Lift	Pick & Place	Walking Beam	Flying Cut-to-Length
Scanning / Inspection	Contoured Glue Dispensing	Palletizing / Depalletizing	Crosscutting / Slitting
Transfer Unit	Part Load & Unload	Material Handling	Mechanical Cam Replacement
Lane Diverter	Profile Engraving / Etching	Storage & Retrieval	Profile Contouring
Backstop Index	Automated Assembly	Parts Transfer	High Speed Winding Traverse

ERV Specifications

ERV-Belt Overview	Units	ERV5		ERV8	
		Standard Carriage	Extended Carriage	Standard Carriage	Extended Carriage
Performance Limits					
Max Thrust (Belt Traction Force) Fx ⁴	lbf (N)	132 (587)	132 (587)	182 (808)	182 (808)
Max Speed	in/s (m/s)	200 (5.0)	200 (5.0)	200 (5.0)	200 (5.0)
Max Acceleration	in/s ² (m/s ²)	386 (9.8)	386 (9.8)	386 (9.8)	386 (9.8)
Max Travel with bumpers	in (mm)	235 (5970)	228 (5800)	233 (5920)	227 (5785)
Max Travel without bumpers	in (mm)	238 (6050)	232 (5900)	237 (6035)	232 (5900)
System Characteristics					
Pulley Lead (travel distance per rev)	mm/rev	100	100	150	150
Pulley Diameter	in (mm)	1.253 (31.83)	1.253 (31.83)	1.880 (47.75)	1.880 (47.75)
Pulley Tooth Count	# Teeth	20	20	30	30
Efficiency ¹ - inline	%	90%	90%	90%	90%
Max Breakaway Torque	oz-in	96	107	177	186
Repeatability ² - inline / parallel	in	±0.004 / ±0.008	±0.004 / ±0.008	±0.004 / ±0.008	±0.004 / ±0.008
System Backlash	in	0.004	0.004	0.004	0.004
Reflected Rotational Inertia					
Base Unit Inertia, 100mm travel	oz-in ²	20.71	29.36	118.79	129.44
Additional Inertia per 100mm travel	oz-in ² /100mm	0.03	0.03	0.05	0.05
Bearing Carriage Load Capacity³					
Normal Load Fz	lbf (N)	253 (1126)	430 (1915)	474 (2112)	807 (3590)
Side Load Fy	lbf (N)	126 (563)	215 (957)	237 (1056)	403 (1795)
Pitch Moment My	ft-lbf (Nm)	39 (53)	145 (197)	109 (148)	311 (422)
Roll Moment Mx	ft-lbf (Nm)	40 (54)	67 (91)	96 (130)	163 (222)
Yaw Moment Mz	ft-lbf (Nm)	32 (43)	103 (140)	78 (106)	215 (292)
Weight & Inertia Data					
Base Unit Weight, Zero Stroke	lb (kg)	10.2 (4.65)	13.4 (6.08)	17.5 (7.96)	22.1 (10)
Carriage Weight	lb (kg)	2.99 (1.36)	5.0 (2.27)	4.82 (2.19)	7.39 (3.35)
Additional Travel Weight	lb (kg) / 100mm	1.0 (0.45)	1.0 (0.45)	1.55 (0.70)	1.55 (0.70)

1. Parallel driven unit efficiency = inline efficiency x 0.9
2. Repeatability is unidirectional achieved under ideal conditions and slow speeds. Actual repeatability may vary with the application.
3. Load Capacities shown are based on 1 billion inches of expected travel life @ 1 m/s.
4. Traction Force is speed dependent. The values shown are based on 0.5 m/s speed.

Operating Temperature Range

0° to 60°C (32° to 140°F)

ERV Series

ERV5 Loading

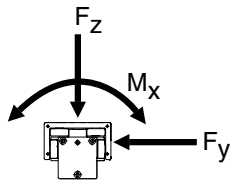
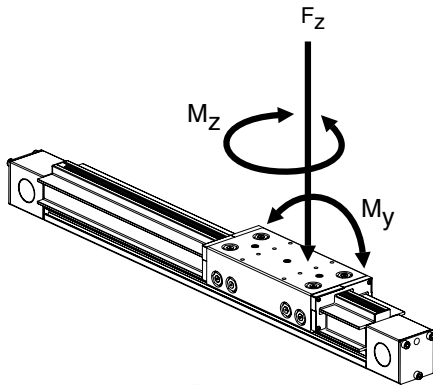

Graph Legend

— 1m/s — 2m/s — 3m/s — 4m/s — 5m/s

Static Moment Loads

Determine which moment loads are induced by the static load. Locate the center of gravity of the load and the length of the moment arm.

Moment Arm Lengths

Determine the moment arm lengths associated with each moment load by measuring the distance from the center of the load to the center of the carriage in each moment load direction.

Pitch Moment

When determining the pitch moment arm, it is necessary to consider the distance from the top of the load attachment plate to the center of the carriage bearings. For the ERV5 Series, this distance is 40mm.

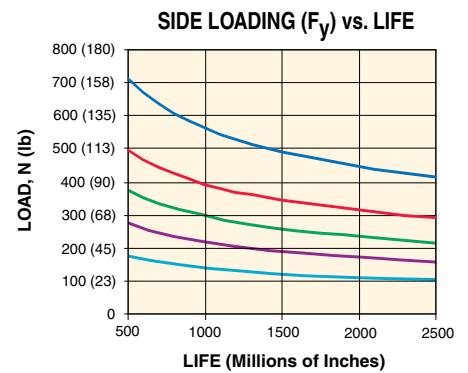
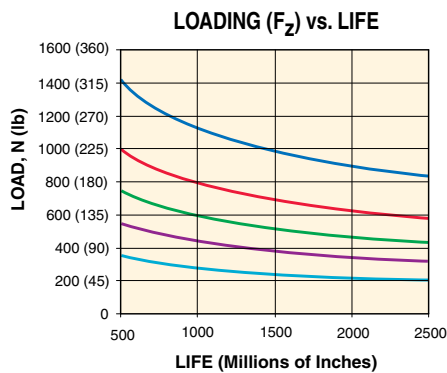

Standard Carriage

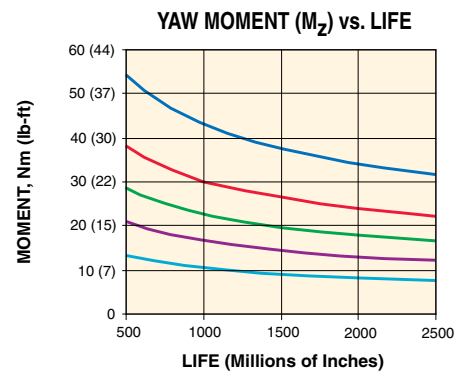
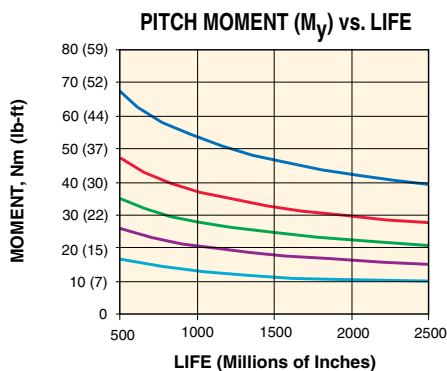
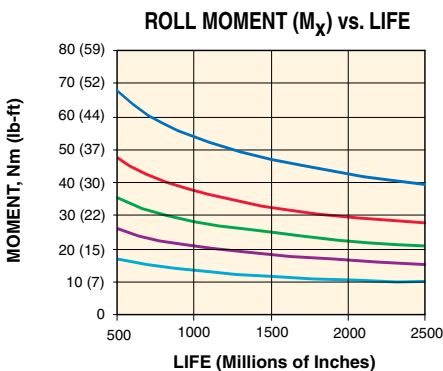

Extended Carriage

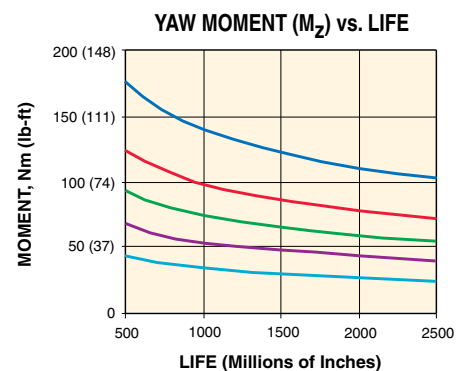
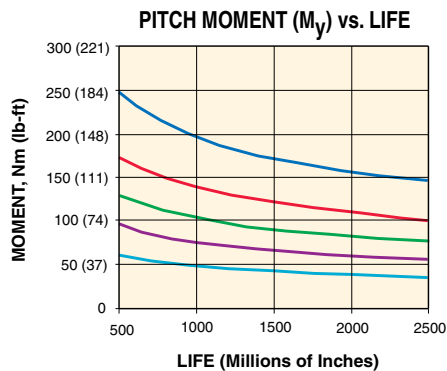
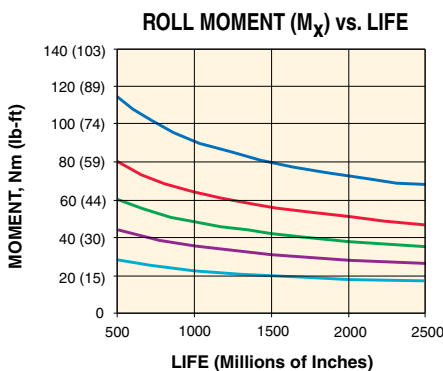

ERV8 Loading

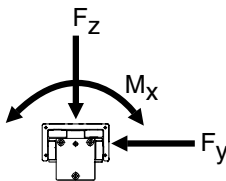
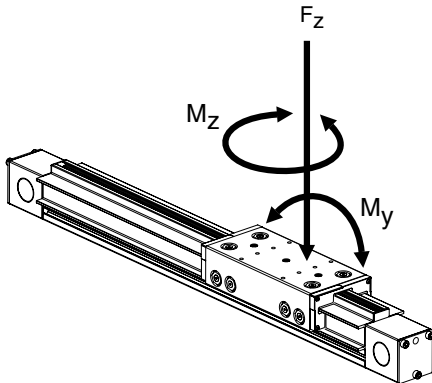

Graph Legend

— 1m/s — 2m/s — 3m/s — 4m/s — 5m/s

Static Moment Loads

Determine which moment loads are induced by the static load. Locate the center of gravity of the load and the length of the moment arm.

Moment Arm Lengths

Determine the moment arm lengths associated with each moment load by measuring the distance from the center of the load to the center of the carriage in each moment load direction.

Pitch Moment

When determining the pitch moment arm, it is necessary to consider the distance from the top of the load attachment plate to the center of the carriage bearings. For the ERV8 Series, this distance is 47mm.

LOADING (F_z) vs. LIFE

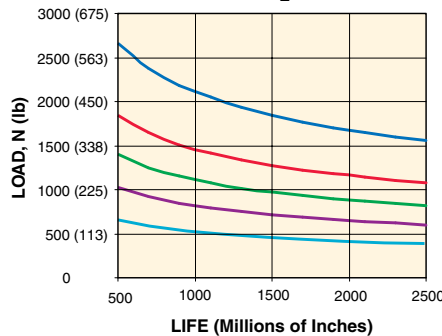

SIDE LOADING (F_y) vs. LIFE

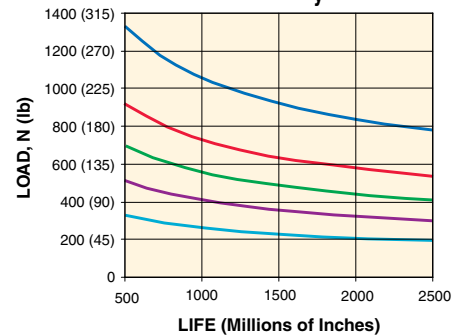

Standard Carriage

ROLL MOMENT (M_x) vs. LIFE

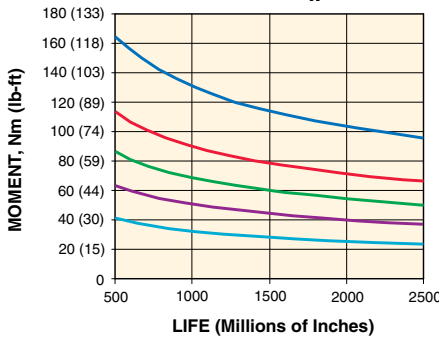

PITCH MOMENT (M_y) vs. LIFE

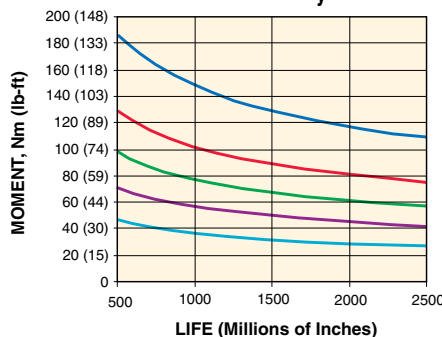

YAW MOMENT (M_z) vs. LIFE

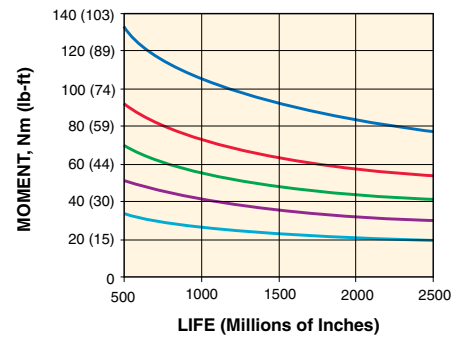

Extended Carriage

ROLL MOMENT (M_x) vs. LIFE

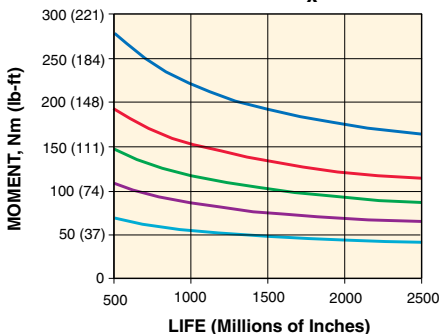

PITCH MOMENT (M_y) vs. LIFE

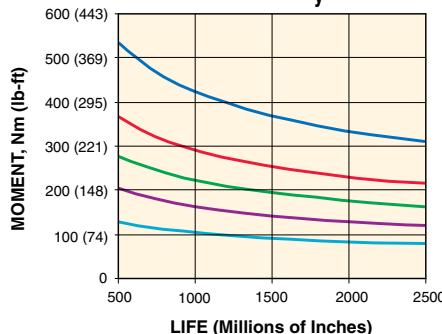

YAW MOMENT (M_z) vs. LIFE

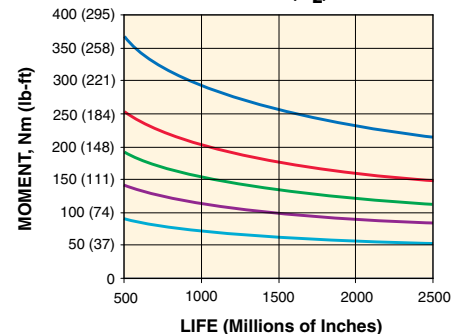

Deflection

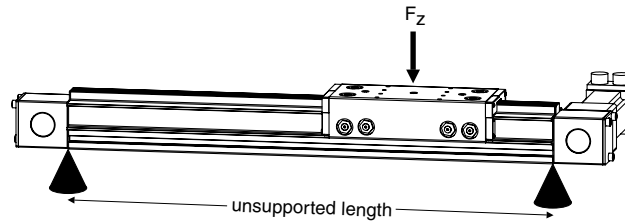

ERV5

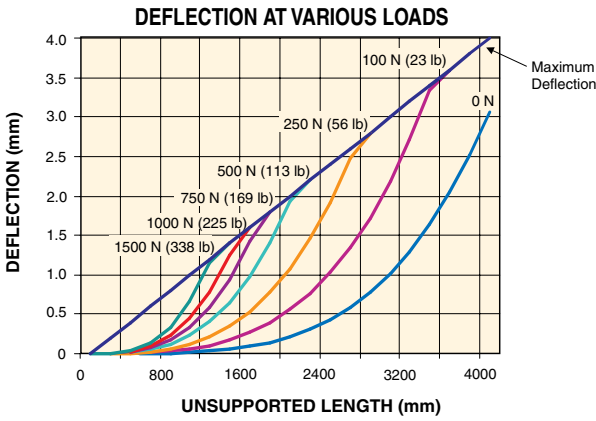

ERV8

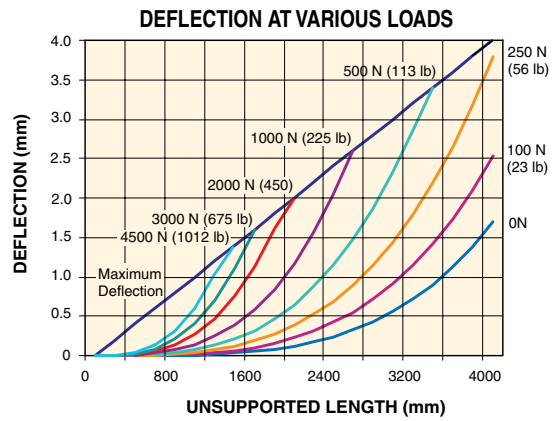

Effective Belt Pull

ERV5

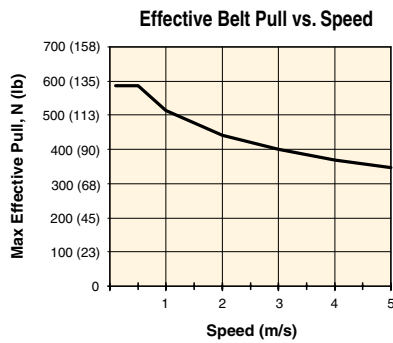

ERV8

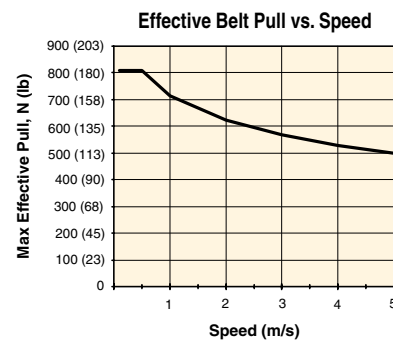

Basic Dimensions

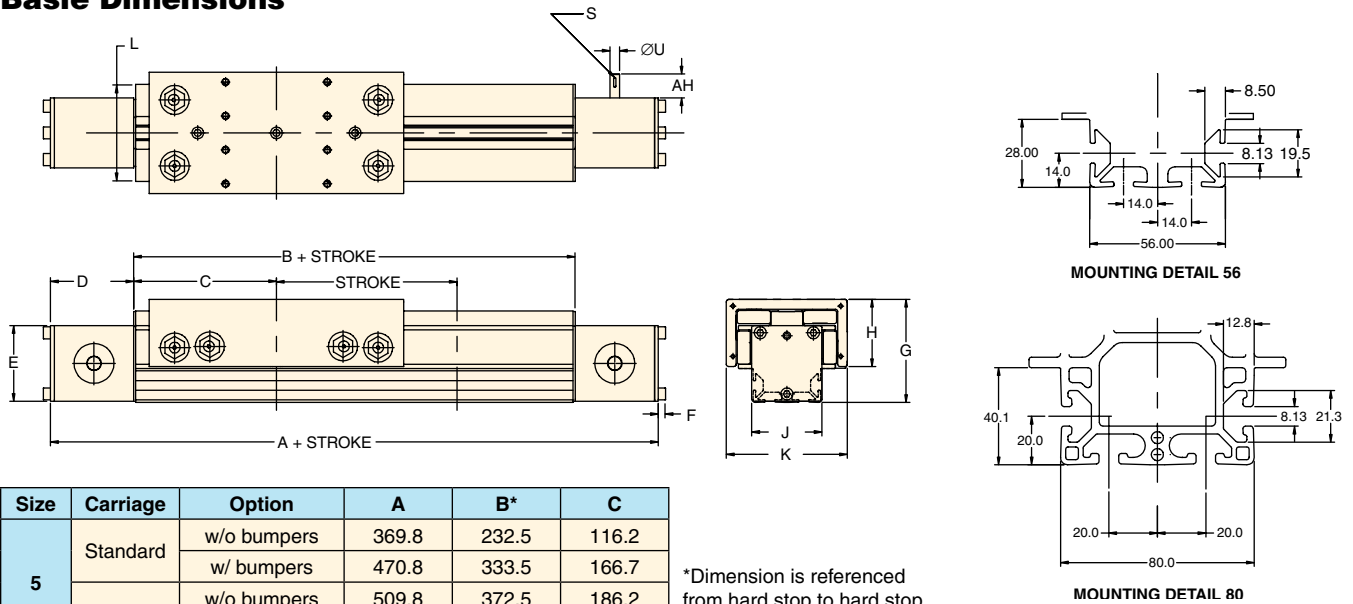

Size	Carriage	Option	A	B*	C
5	Standard	w/o bumpers	369.8	232.5	116.2
		w/ bumpers	470.8	333.5	166.7
	Extended	w/o bumpers	509.8	372.5	186.2
		w/ bumpers	610.8	473.5	236.7
8	Standard	w/o bumpers	473.8	272.5	136.2
		w/ bumpers	586.8	386.0	193.0
	Extended	w/o bumpers	598.8	397.5	198.7
		w/ bumpers	711.8	511.0	255.5

*Dimension is referenced from hard stop to hard stop.
NOTE:
 Felt wipers do not increase A, B or C dimensions.

Size	D	E	F	G	H	J	K	L	U	AH	S
5	68.7	62.5	6.0	85.0	55.5	58.0	100.0	80.0	7.96	19.7	M2 X 6
8	100.7	84.0	6.0	110.0	67.5	80.0	130.0	106.0	13.95	32.0	M5 X 9

Carriage Mounting Detail

ERV5 Standard Carriage

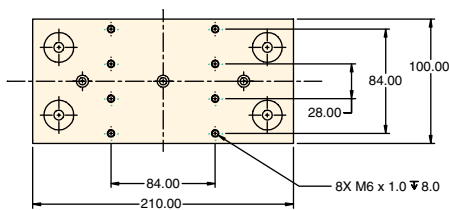

ERV5 Extended Carriage

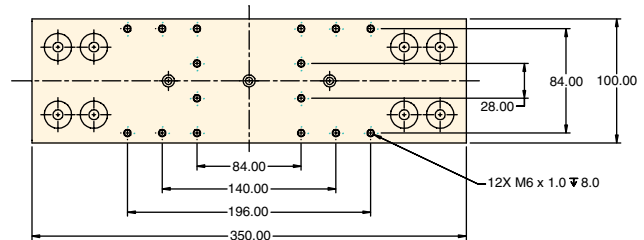

ERV8 Standard Carriage

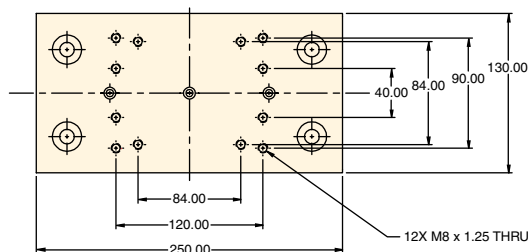

ERV8 Extended Carriage

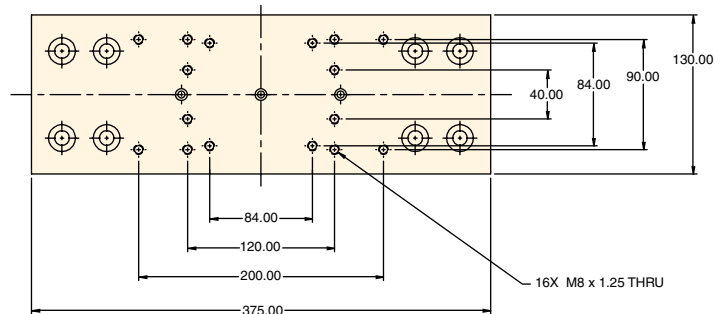

Carriage Style (S, L)

Standard carriage



Extended carriage



Carriage Features

- Bearing Wheels
 - 12 wheels for standard carriage
 - 24 wheels for extended carriage
- Eccentric Pre-loaded wheels
- Concentric Wheel
- 2 options for carriage loading,
 - Positive (Toward Actuator)
 - Negative (Away from Actuator).
- Magnet for Limit and Home Switches.

Spliced Units

Standard units are available in lengths up to 20 feet. For additional length, spliced units are available.

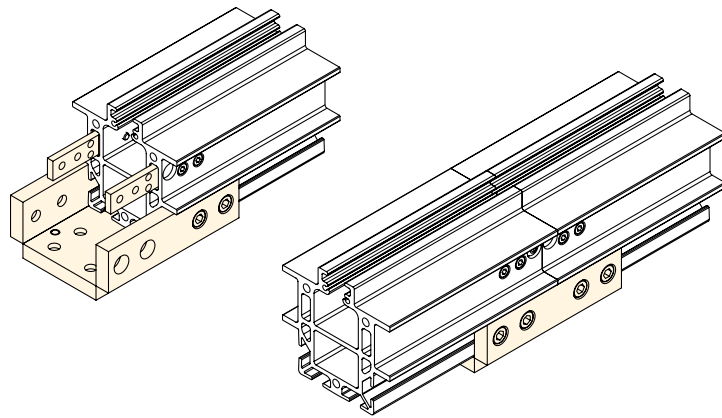
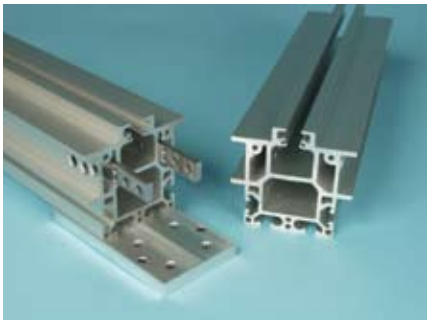

Bumpers (B)

Optional bumpers are designed to prevent over-travel and can be adjusted along the full length of travel. The bumpers are fixed to the actuator extrusion via a standard T-slot (M8 SHCS and T-nut).

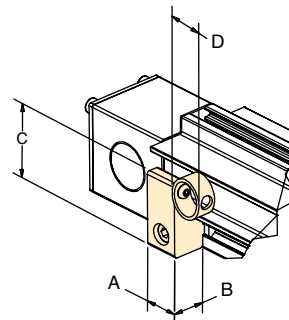

Model	A	B	C	D
ERV5	25.4	23.9	52.5	25.1
ERV8	25.4	30.3	71	31.1

Felt Wiper (W)

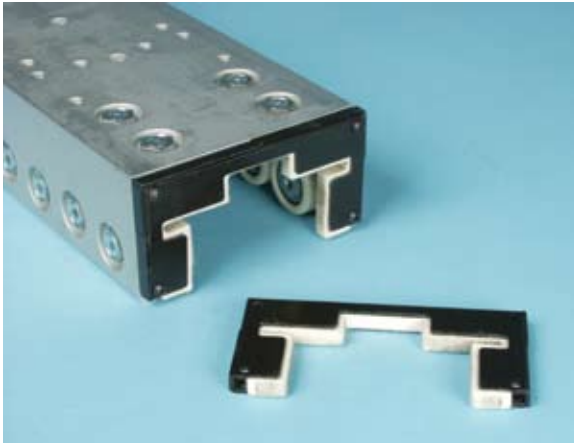

Although not 100% sealed, the felt wiper option is designed to wipe contaminants away from entering the carriage assembly.

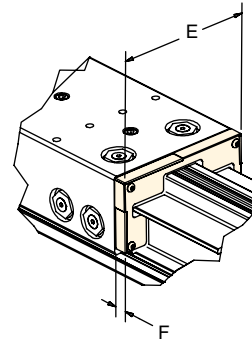

Carriage with Wiper

Carriage without Wiper

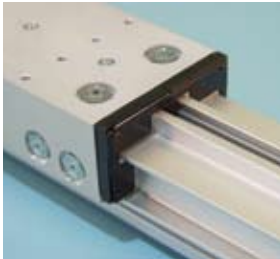

Model	E	F
ERV5	99	9.5
ERV8	129	9.5

Machined Gussets

Machined gussets provide a high strength, accurate right angle connection for ERV5 profiles. The mounting surfaces are milled perpendicular.

Material: 6063-T6 Aluminum alloy, clear anodized
Machining: None



Model	Gusset Part Number	Recommended Fasteners
ERV5	20-2828M	(2) 24-112-6 BHSCS and (2) 20-099 Drop-in T-Nuts
	20-2856M	(4) 24-112-6 BHSCS and (4) 20-099 Drop-in T-Nuts
ERV8	20-4040M	(2) 20-118-8 BHSCS and (2) 20-098 Drop-in T-Nuts
	20-4080M	(4) 20-118-8 BHSCS and (4) 20-098 Drop-in T-Nuts

Drop-In T-Nuts

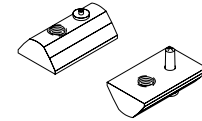

20-2828M Dimensions

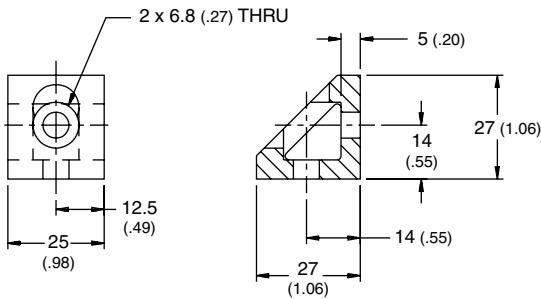

20-2856M Dimensions

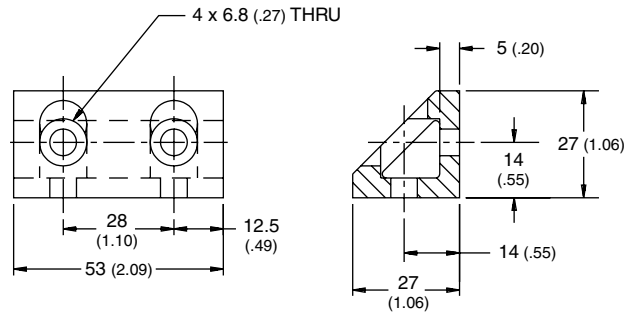

20-4040M Dimensions

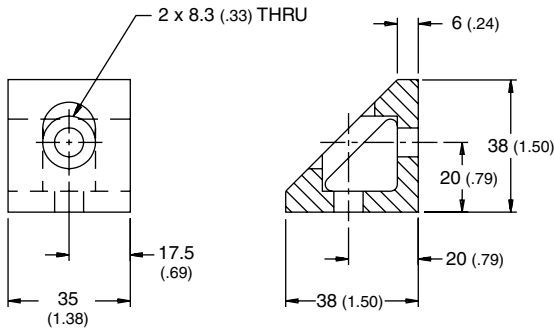

20-4080M Dimensions

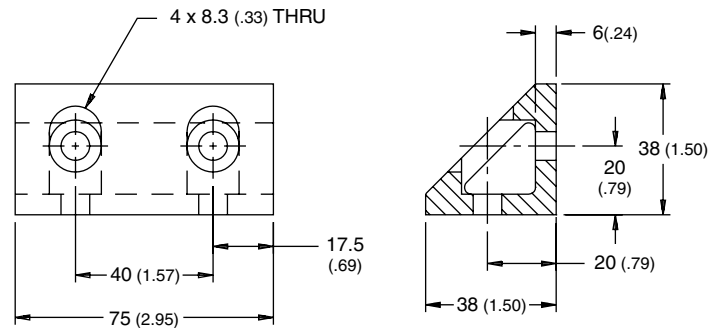

Toe Clamp

For attachment of ERV8 profiles to each other, to a structural profile or a mounting surface. Must be used in pairs. Requires M6 socket head cap screws.

Part Number 500-000900

Dimensions

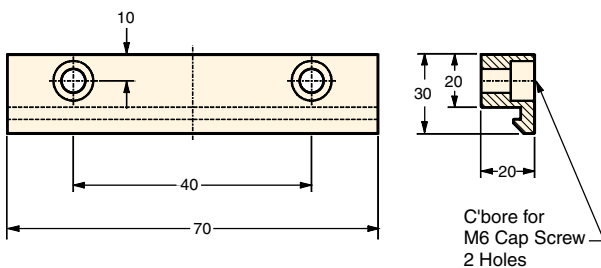

M6 Socket Head Cap Screws

Length (mm)	Part Number
10	24-310-6
12	24-312-6
14	24-314-6
16	24-316-6
20	24-320-6
25	24-325-6
27	24-327-6
30	24-330-6
33	24-333-6
35	24-335-6
40	24-340-6
45	24-345-6
50	24-350-6
80	24-380-6
90	24-390-6
100	24-3100-6

Sensors



Two types of Hall effect sensors are available for use with ERV Series actuators. The normally open sensor is typically used for mid-position sensing, such as homing applications. The normally closed sensor is generally used to indicate over-travel at the end of the stroke, and is used in a safety circuit to prevent damage to components caused by over-travel.

Hall Effect Specifications

	Solid State
Type	Solid State Type (PNP or NPN)
Switching Logic	Normally Open or Normally Closed
Supply Voltage Range	5 - 24 VDC
Switch Current	150 mA max
Current Consumption	7 mA at 12 VDC, 14 mA at 24 VDC
Switching Response	500 Hz Maximum
Residual Voltage	0.8 V Maximum (150 mA)
Leakage Current	10 uA Maximum
Insulation Resistance	100 M Ohm min.
Min. LED Current	1mA
Operating Temperature	-10° to 85°C (14° to 185°F)**
Lead Termination	1500 mm (60 in) or 150mm (6 in) w/connector
Industrial Protection	IP67
Shock Resistance	50 g's, 490 m/sec ²

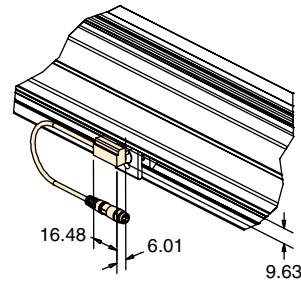
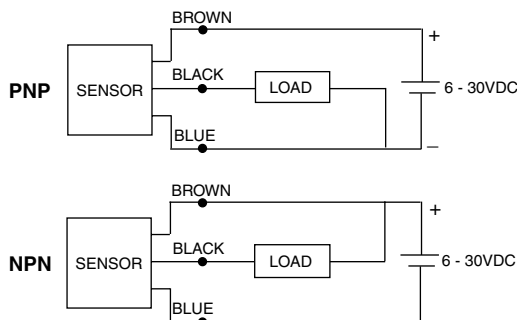

Hall Effect Sensors with Clamp

Part No.**	Type	LED Color	Logic	Cable/Connector
SMHnn-1P	N.O.	Green	PNP	1.5m Black with Leads
SMHnn-1N	N.O.	Red	NPN	
SMCnn-1P	N.C.	Yellow	PNP	
SMCnn-1N	N.C.	White/Red	NPN	150mm Black with Connector*
SMHnn-1PC	N.O.	Green	PNP	
SMHnn-1NC	N.O.	Red	NPN	
SMCnn-1PC	N.C.	Yellow	PNP	
SMCnn-1NC	N.C.	White/Red	NPN	

* Mating sensor cable assembly **B8786** purchased separately.
 ** nn = V5 to fit ERV5 or V8 to fit ERV8

Dimensions

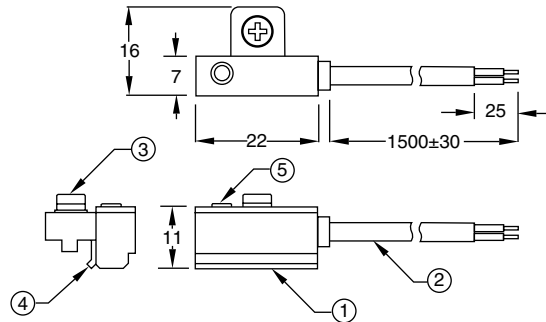

- Housing material: plastic
- Cable type: Ø3.3mm, 3C wire, 24AWG
- Clamp screw: M3x8mm, stainless steel
- Adjustable clamp: stainless steel
- LED color when activated: red
- IP67 and CE certified

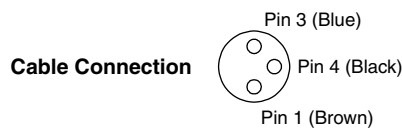
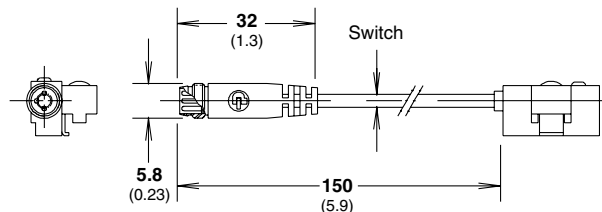

ERV Ordering Information



Continued on next page

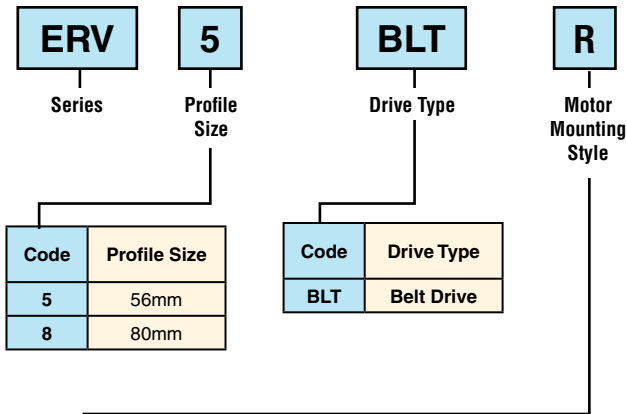

Code	Profile Size
5	56mm
8	80mm

Code	Drive Type
BLT	Belt Drive

Code	Motor Mounting Style	
R	Direct Drive Right	
L	Direct Drive Left	
M	Parallel Over Right with Timing Belt or Gear Drive	
N	Parallel Under Right with Timing Belt or Gear Drive	
S	Parallel Over Left with Timing Belt or Gear Drive	
T	Parallel Under Left with Timing Belt or Gear Drive	
V	Reverse Parallel Over Right with Timing Belt or Gear Drive	
W	Reverse Parallel Under Right with Timing Belt or Gear Drive	
Y	Reverse Parallel Over Left with Timing Belt or Gear Drive	
Z	Reverse Parallel Under Left with Timing Belt or Gear Drive	
J	Reverse Parallel Rear Right with Timing Belt or Gear Drive	
K	Reverse Parallel Rear Left with Timing Belt or Gear Drive	

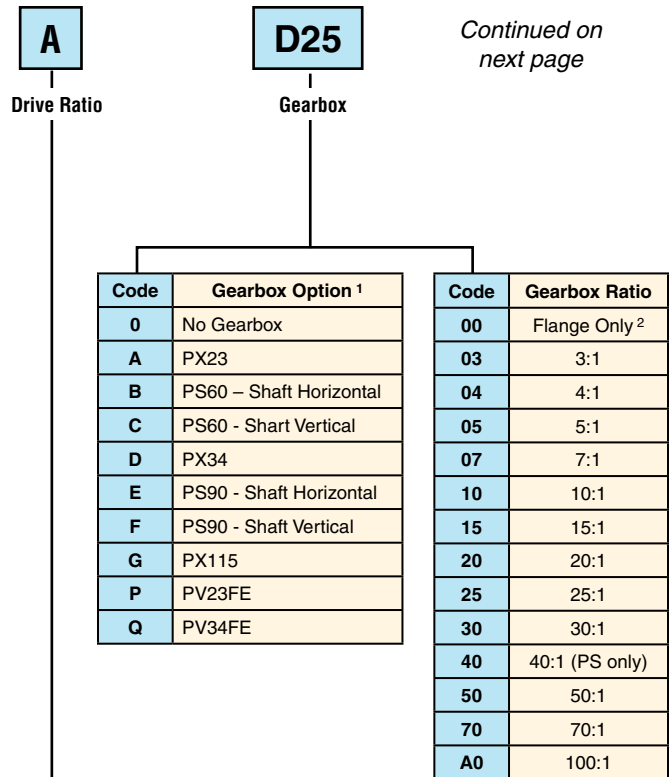

Code	Gearbox Option ¹
0	No Gearbox
A	PX23
B	PS60 – Shaft Horizontal
C	PS60 - Shaft Vertical
D	PX34
E	PS90 - Shaft Horizontal
F	PS90 - Shaft Vertical
G	PX115
P	PV23FE
Q	PV34FE

Code	Gearbox Ratio
00	Flange Only ²
03	3:1
04	4:1
05	5:1
07	7:1
10	10:1
15	15:1
20	20:1
25	25:1
30	30:1
40	40:1 (PS only)
50	50:1
70	70:1
A0	100:1

Code	Drive Ratio
A	1:1 Inline 1:1 Timing Belt (Parallel)
B	1.5:1 Timing Belt (Parallel)
D	2:1 Timing Belt (Parallel)
K	1:1 Gear Drive (Parallel)
E	3:1 Gear Drive (Parallel)
F	5:1 Gear Drive (Parallel)
G	7.5:1 Gear Drive (Parallel)
H	9.5:1 Gear Drive (ERV5 Parallel) 10:1 Gear Drive (ERV8 Parallel)

¹ Not all motor/gearbox options physically fit on all cylinder sizes and mounting styles. Reference mounting matrix to determine suitable combinations. PS precision gearboxes are oil filled. Shaft orientation is required to insure proper oil fill levels.

² When combined with Gearbox Option "0" (no gearbox), this option is direct mount with no flange included.

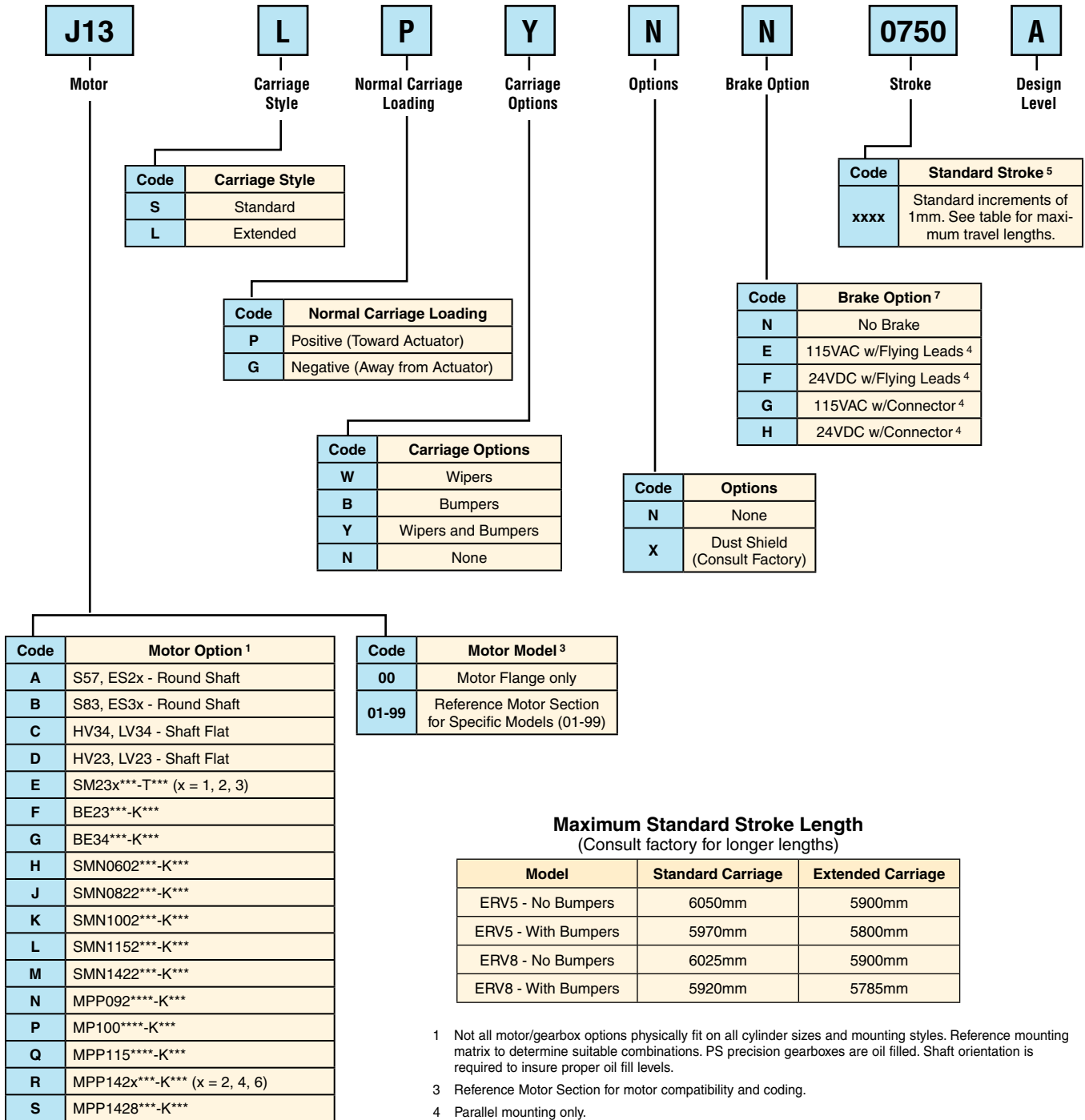

ERV Application Fax Form



Fax completed form to (330) 334-3335 or email to actuatorsales@parker.com

Contact Information:

Name _____ Phone _____
 Company _____ email _____
 City, State, Zip _____

Application Sketch

NOTES:

Please include the critical dimensions in your sketch.

In order to achieve the best solution, it is important that you provide as much information as possible.

Motion Profile

Moves	Distance (Stroke)	Time	Thrust or Load	Dwell
First Motion				
Second Motion				
Third Motion				
Fourth Motion				

Moment Loading

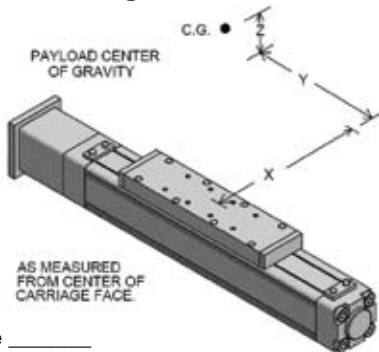

X distance _____
 Y distance _____
 Z distance _____

Application Requirements:

- Overall Stroke** (add 25mm per end minimum) _____
- Cylinder Orientation** (check one)
 - Horizontal Inverted Side Mount
 - Vertical Angle: Degree _____
- Load/Tooling Weight** _____
- Repeatability Requirements** _____
 - Unidirectional Bidirectional
- Is the load externally guided?** (check one)
 - Yes No
 - If yes, how? _____
- Is the actuator body supported?** (check one)
 - Yes No
 - If yes, how? _____
- Life Requirements** (cycles, distance or years)
 - Hours per day _____ Days per year _____
- Special Considerations** _____

Please attach another sheet if more room is needed.

Environmental Requirements

- Operating Temperature**
 Max _____ Min _____
- Contamination** (check one)
 - Particle Liquid
 - Type: _____
- Special Considerations** _____

Actuator Type and Mounting

1. Carriage Type (check one)

 Standard

 Extended

 No Preference

2. Carriage Options (check one)

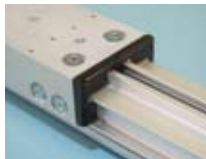
 Wipers

 Bumpers

 Wipers & Bumpers



3. Motor Mount (check one)

 Inline – Direct Drive Left (shown)

 Inline – Direct Drive Right

 Parallel Over Right

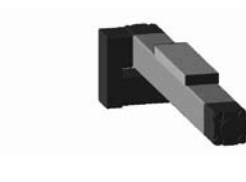
 Parallel Over Left

 Parallel Under Right

 Parallel Under Left

Parallel mounts can limit the actuator's total thrust capacity.

 Other Parallel Option (select from catalog page 64) _____

Motor, Drive and Control Options:

1. Motor Options (check all that apply)

 Stepper

 Servo

 Parker Supplied

 Customer Supplied (provide print)

 Gearhead

2. Other Options (check one)

 Drive

 Drive/Controller

 Controller

3. Available Line Voltage _____

4. Switches/Sensors (quantity)

End of Travel _____

Home _____

5. Brake Option (check one)

 Motor

 None

6. Special Options _____

ERV Series

