



# *Vertical actuators*

*HTR Telescopic actuator with belt drive*

*HZR Z-axis with belt drive*

*Catalogue: 192-560011N4/UK  
Version 4 / March 2002*

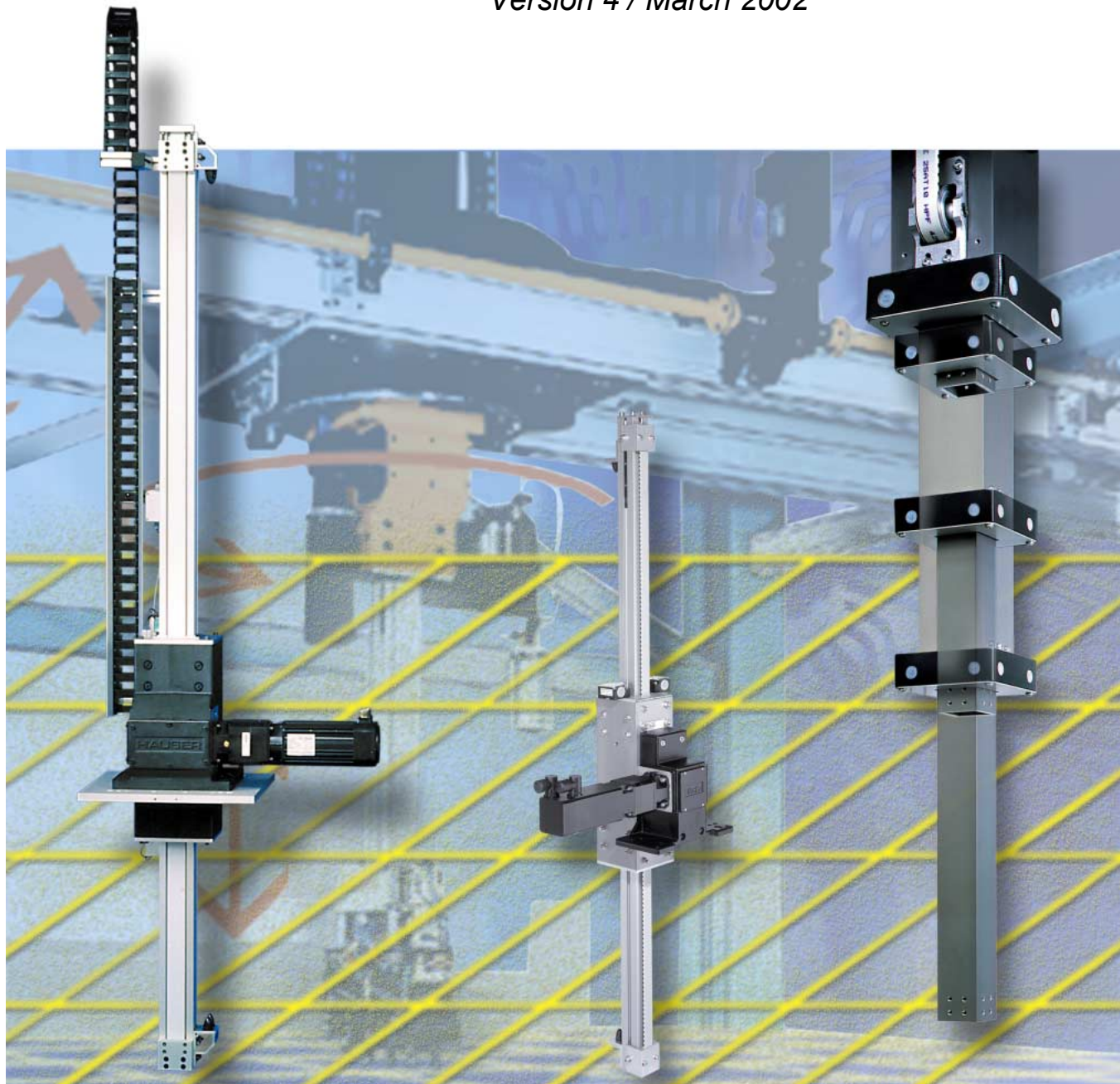

# HTR – Telescopic actuator with belt drive

---

**HTR dynamic telescopic actuator**

Telescopic actuator with belt drive - for vertical applications where height is limited.

**Contents:**

HTR Characteristics .....	3
Product description.....	4
Technical data.....	5
HTR Dimensions.....	6
HTR – HLE/HPLA Combinations.....	8
Order code .....	13
Accessories .....	30
Cable carrier .....	30
Attachment of position sensors and accessories ...	32
Limit switch gearbox for HTR.....	35
Assembly angle plate for HTR .....	36
Other accessories / software .....	38

**HTR Characteristics**

- ◆ Long stroke (maximum 2500mm) with minimum overall height.
- ◆ High working load up to 50kg.
- ◆ Can be combined with HLE and HPLA linear actuators in a modular system
- ◆ Withstands high side loads and moments- even when extended - by means of the closed and torsion-resistant aluminium telescope profile.
- ◆ Backlash-free guidance by means of adjustable, plastic rollers mounted on roller bearings.
- ◆ Maintenance-free, low-noise plastic rollers with PA coating.
- ◆ Non-wearing and non-slip toothed belt drive.
- ◆ Available in two sizes: T3B050 and T3B080.

Subject to technical modifications. Data correct at time of printing.

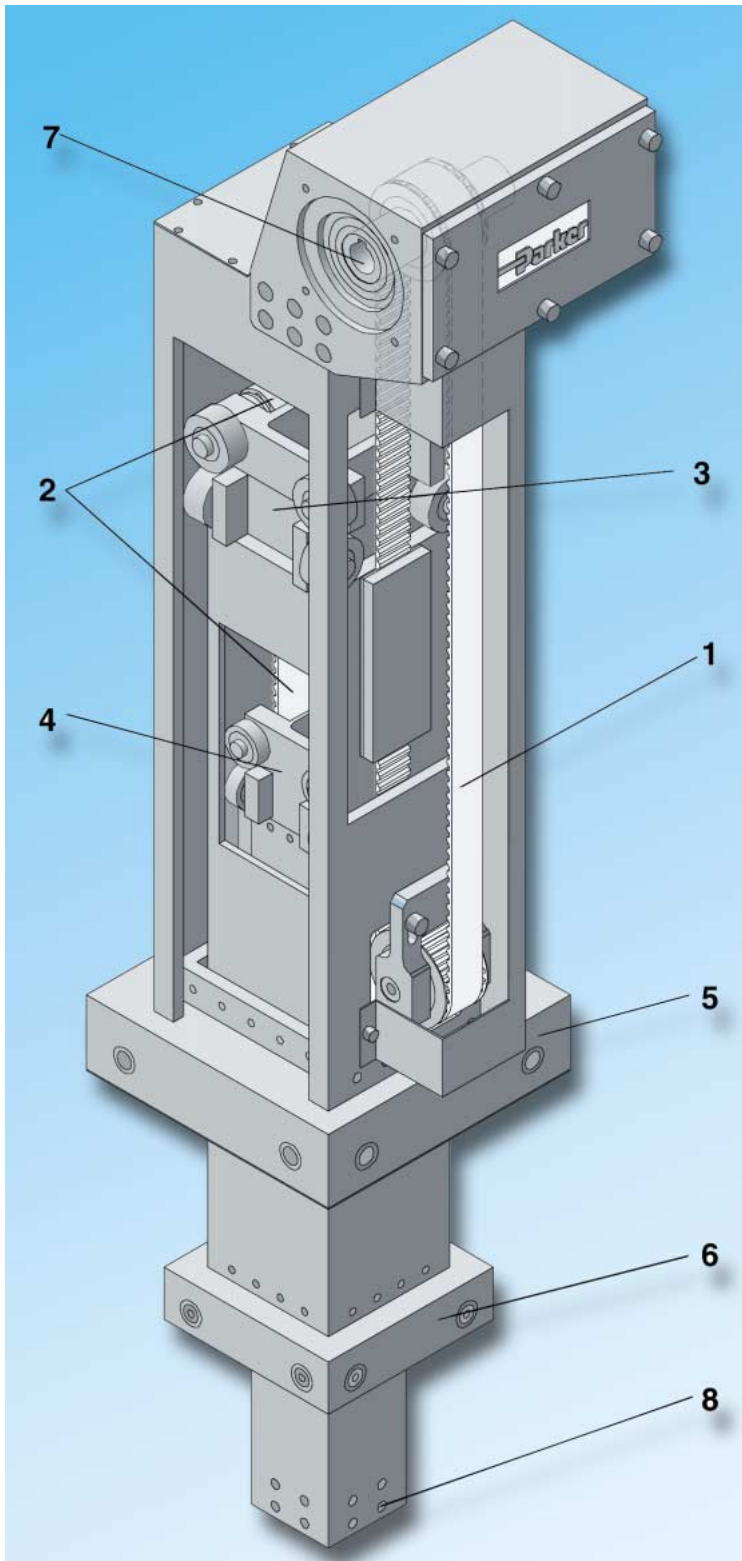
**Product description****Long stroke with minimum overall height**

Parker has developed and specially designed the telescopic actuator for applications that require a long vertical lifting path in a limited space.

The non-wearing, high strength toothed belt of the main drive (1) and the transmission drive (2) ensure optimal power transfer to the load attachment (8).

Maintenance free plastic rollers mounted on roller bearings, combined with surface treated aluminium extrusion profiles, guarantee minimum wear with optimal running smoothness.

A newly developed guiding principle, consisting of the 3 guide profiles and the relevant roll mounting stations (3 to 6), ensures self-stabilising properties.

The hollow shafts and flange design of the drive station (7) are identical to the flange dimensions of our servo drives, offering optimal combinations with our drive technology.

HTR connections and attachments are compatible with the Parker modular system, which means that modular application-specific handling can be provided in combination with linear actuators.

Parker's proven design principles provide the user with numerous advantages including applications with the telescopic actuator.

# HTR – Telescopic actuator with belt drive

## Technical data

HTR size	Unit	T3B050	T3B080
----------	------	--------	--------

### Weight and moment of inertia

Weight of basic unit without stroke	kg	12.8	35.3
Weight of additional length	kg/m	8.0	16.2
Weight of the moving parts, no stroke	kg	2.8	7.4
Weight of the moving parts, to be added per metre of stroke	kg/m	2.4	4.5
Mass moment of inertia, related to the drive shaft, no stroke	kgcm <sup>2</sup>	52.4	302.8
Additional mass moment of inertia related to the drive shaft per metre of stroke	$\frac{\text{kgcm}^2}{\text{m}}$	49.2	202.3

### Travel paths and speeds

Maximum travel speed	m/s	5.0	5.0
Maximum travel path	mm	2500	2500
Maximum permissible acceleration	m/s <sup>2</sup>	5	5

### Accuracy

Repeatability in one direction (DIN EN ISO 9283)	mm	±0.2	±0.2
--	----	------	------

### Geometrical data

Cross-section outer profile	mm x mm x mm	125 x 125 x 6	180 x 180 x 10
Cross-section central profile	mm x mm x mm	80 x 80 x 6	125 x 125 x 6
Cross-section inner profile	mm x mm x mm	50 x 50 x 5	80 x 80 x 6
Moment of inertia of the outer profile ( $I_x = I_y$ )	cm <sup>4</sup>	676	3261
Moment of inertia of the centre profile ( $I_x = I_y$ )	cm <sup>4</sup>	163	676
Moment of inertia of the inner profile ( $I_x = I_y$ )	cm <sup>4</sup>	31	163

### Pulley and toothed belt data, torques and forces

Travel distance per revolution <sup>1</sup>	mm/rev	340					480				
Pulley diameter <sup>1</sup>	mm	108.2					152.8				
Toothed belt width/pitch:											
Main drive (refer to Item 1, page 4)	mm	25 / 10					32 / 10				
Transmission drive (refer to Item 2, page 4)	mm	25 / 5					32 / 5				
Maximum drive torque	Nm	40					108				
Maximum belt traction at travel speed	m/s	1	2	3	4	5	1	2	3	4	5
	N	444	339	288	256	233	922	707	602	535	488
Belt traction (effective load), maximum <sup>2</sup>	N	245					491				



Technical data issued 03/02, safety factor taken into consideration  $S=1$ . Data applies for a temperature range of between  $-10^{\circ}\text{C}$  and  $+40^{\circ}\text{C}$ . The technical data applies under standard conditions and only for the individually specified operating mode and nature of load. In the case of compound loads, it must be verified in accordance with the laws of physics and technical standards, whether single data have to be reduced. Please contact us in the case of doubt.

<sup>1</sup> Calculated value, taking into account telescope ratio 1:2

<sup>2</sup> Exact calculations of the load-bearing capacity can be made with the "DimAxes" software (see page 38)

# HTR – Telescopic actuator with belt drive

## HTR Dimensions

### T3B050

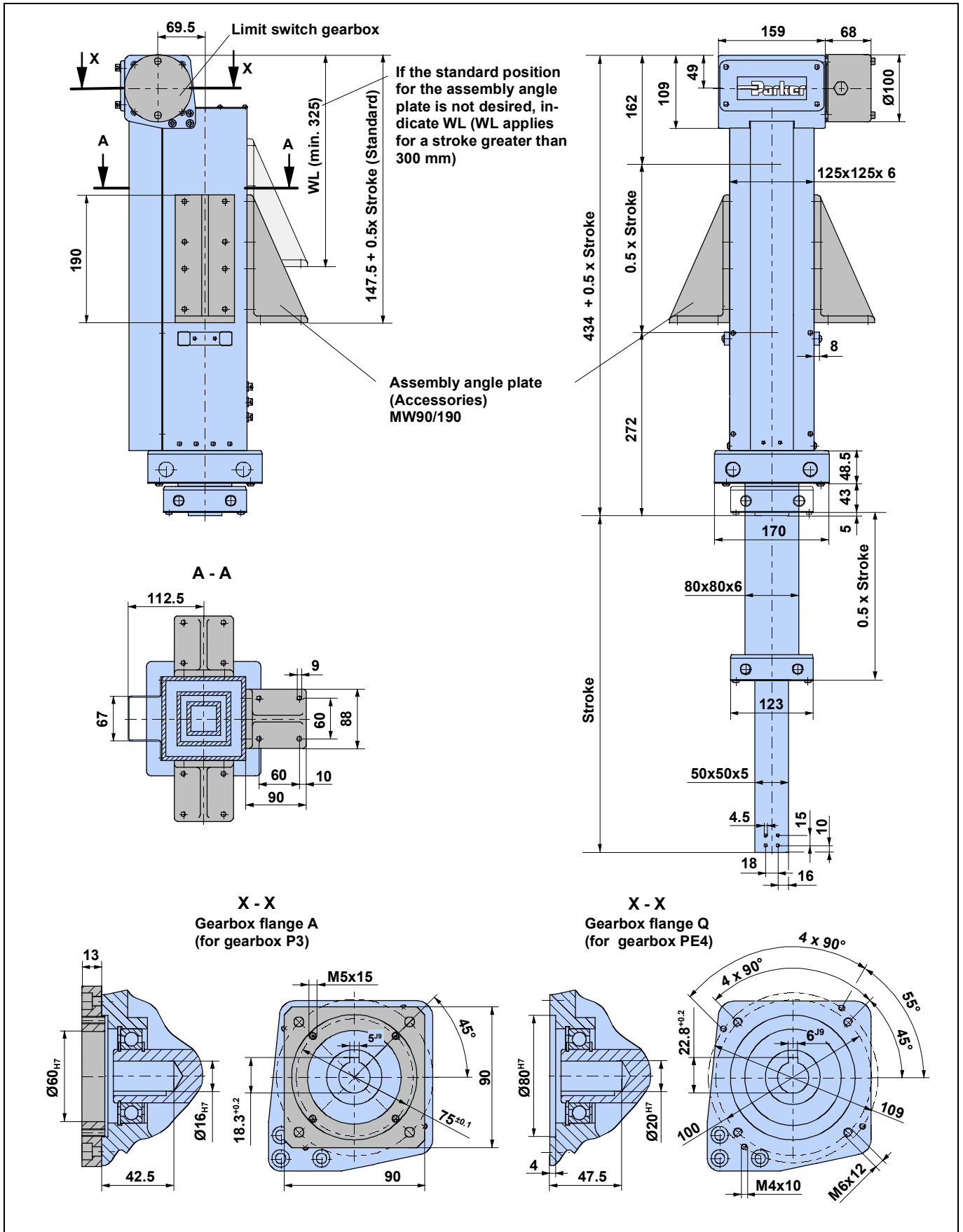

# HTR – Telescopic actuator with belt drive

T3B080

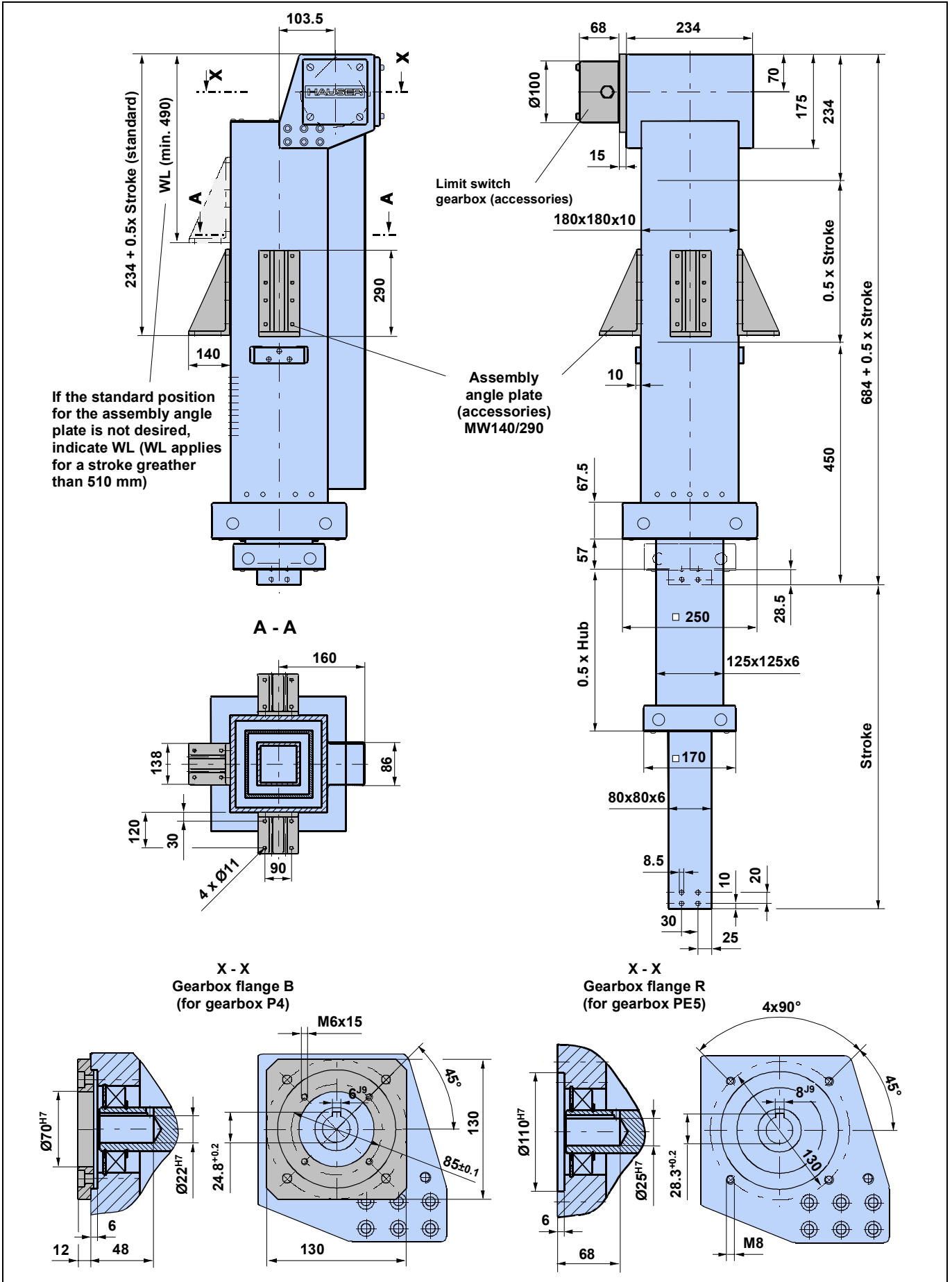

# HTR – Telescopic actuator with belt drive

## HTR – HLE/HPLA Combinations

### Overview of all possible combinations

T3B050 with HPLA/HLE	See page
T3B050 – LB..080F Dual actuator / LB..080E Dual actuator	8
T3B050 – LB..080F Dual actuator / LEB100E Dual actuator	8
T3B050 – LEB100F Dual actuator / LEB100E Dual actuator	9
T3B050 – LEB100F Dual actuator / LB..120E Dual actuator	9
T3B050 – LB..120F Dual actuator / LB..120E Dual actuator	9
T3B080 with HPLA/HLE	See page
T3B080 – LEB100F Dual actuator / LB..120C Dual actuator	10
T3B080 – LEB100F Dual actuator / LEB150C Dual actuator	10
T3B080 – LB..120F Dual actuator / LB..120C Dual actuator	10
T3B080 – LB..120F Dual actuator / LB..180E Dual actuator	11
T3B080 – LEB150F Dual actuator / LEB150C Dual actuator	11
T3B080 – LEB150D Dual actuator / LEB150C Dual actuator	11
T3B080 – LEB150D Dual actuator / LB..180E Dual actuator	12

### T3B050 – LB..080F Dual actuator / LB..080E Dual actuator

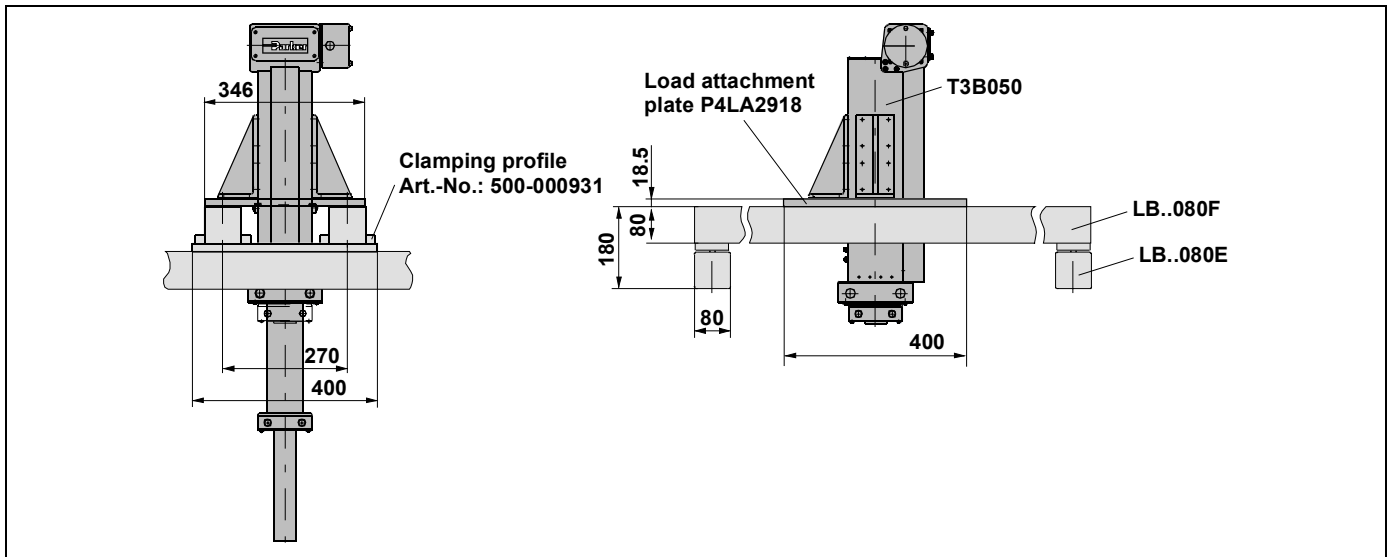

### T3B050 - LB..080F Dual actuator / LEB100E Dual actuator

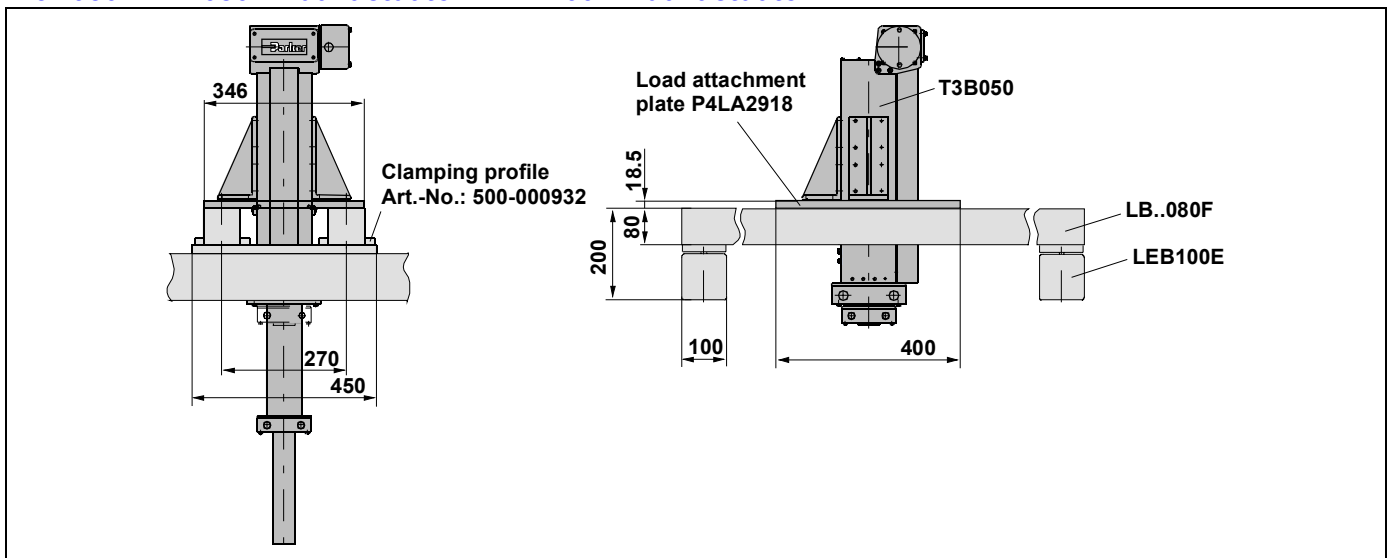



# HTR – Telescopic actuator with belt drive

## T3B050 - LEB100F Dual actuator / LEB100E Dual actuator

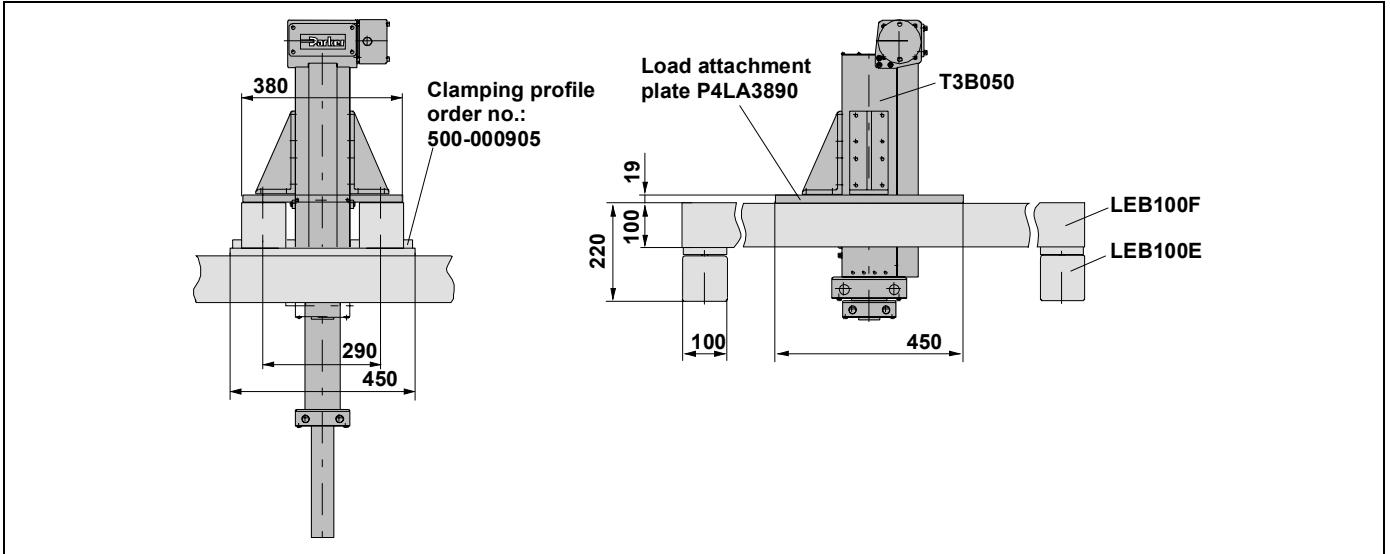

## T3B050 - LEB100F Dual actuator / LB..120E Dual actuator

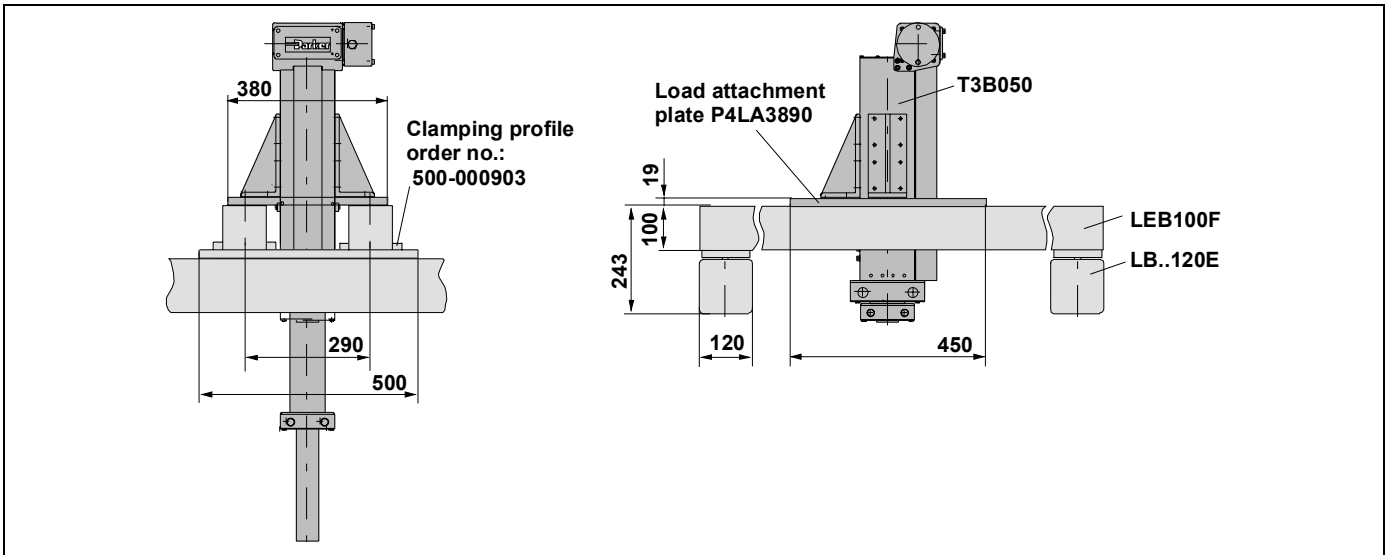

## T3B050 – LB..120F Dual actuator / LB..120E Dual actuator

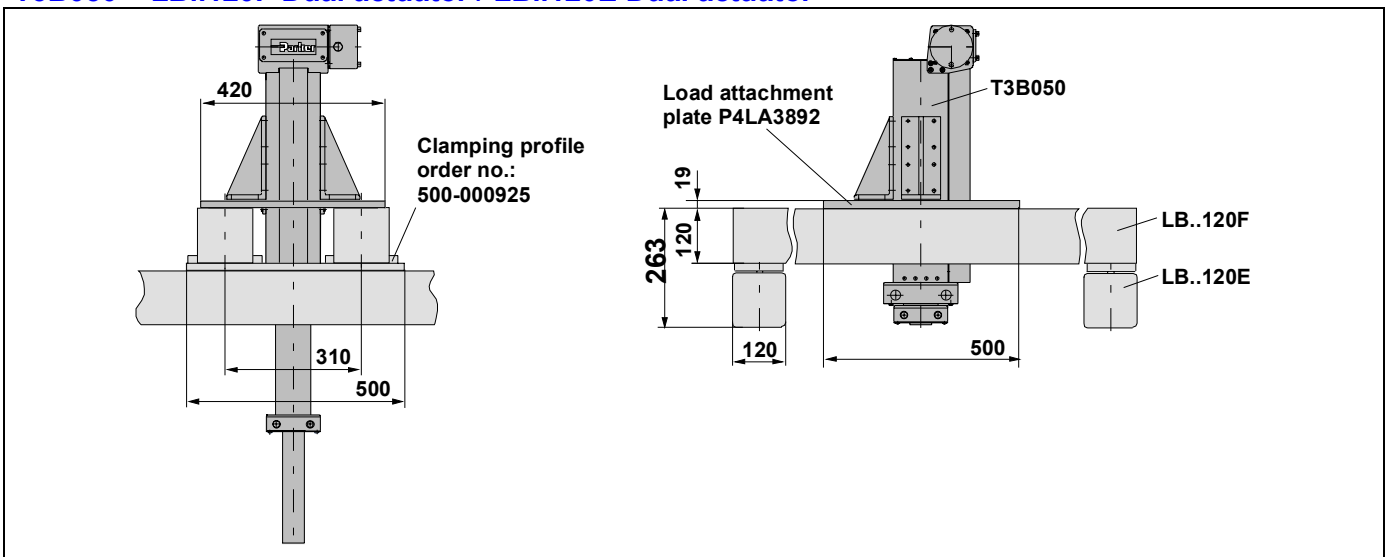

# HTR – Telescopic actuator with belt drive

## T3B080 - LEB100F Dual actuator / LB..120C Dual actuator

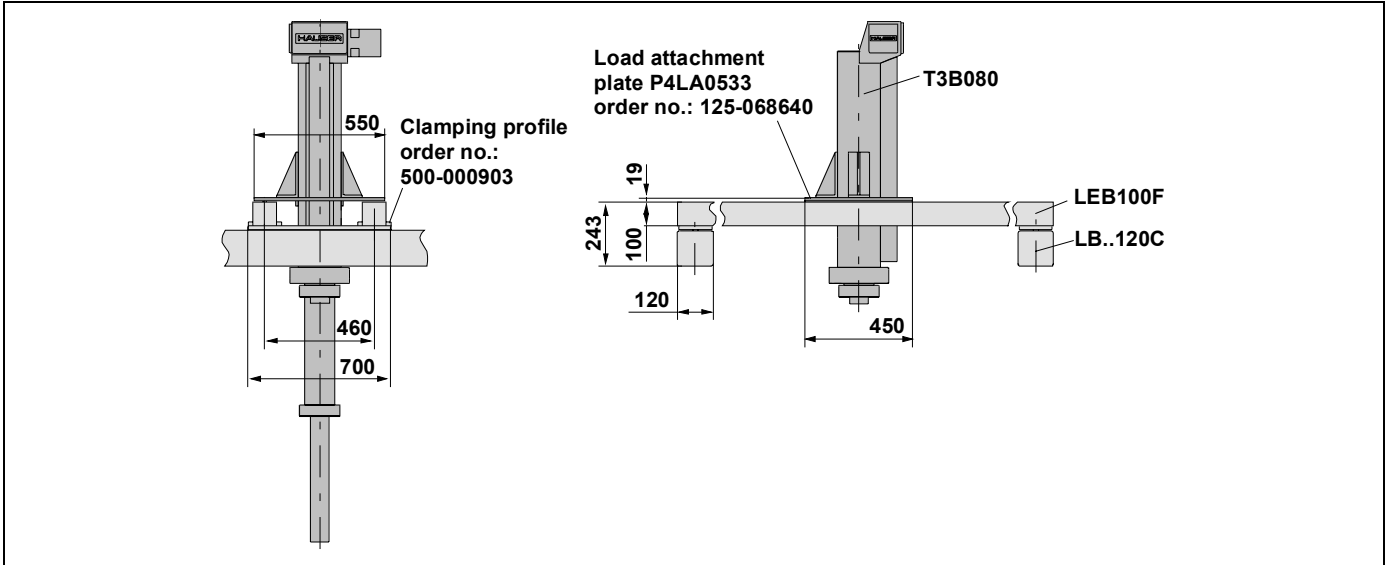

## T3B080 - LEB100F Dual actuator / LEB150C Dual actuator

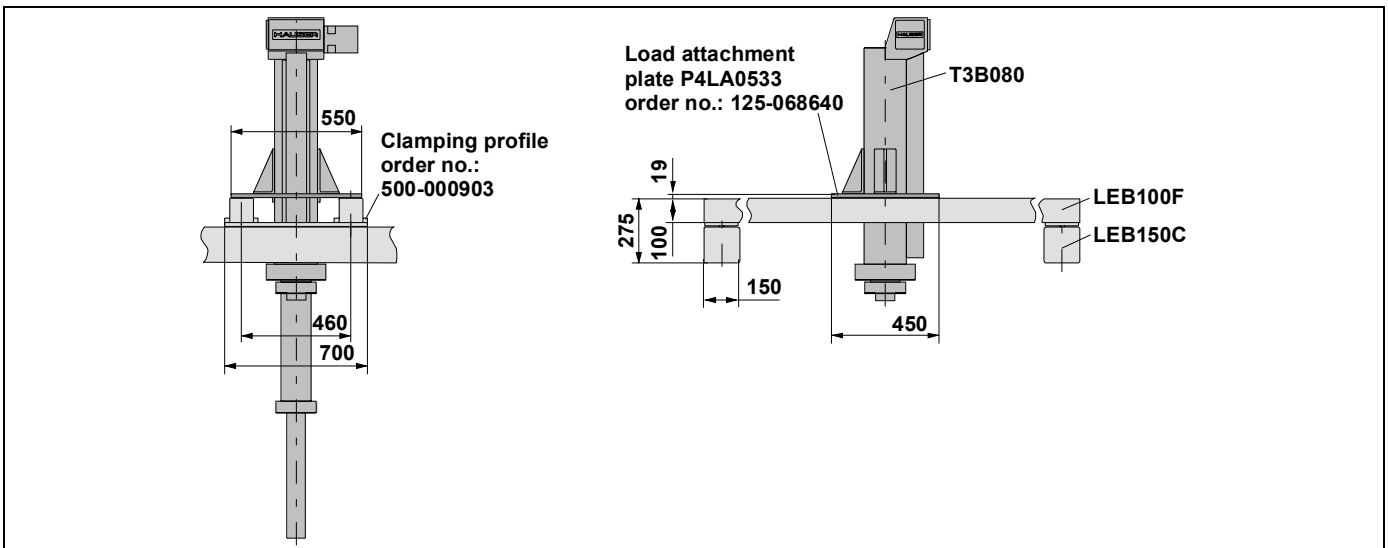

## T3B080 – LB..120F Dual actuator / LB..120C Dual actuator

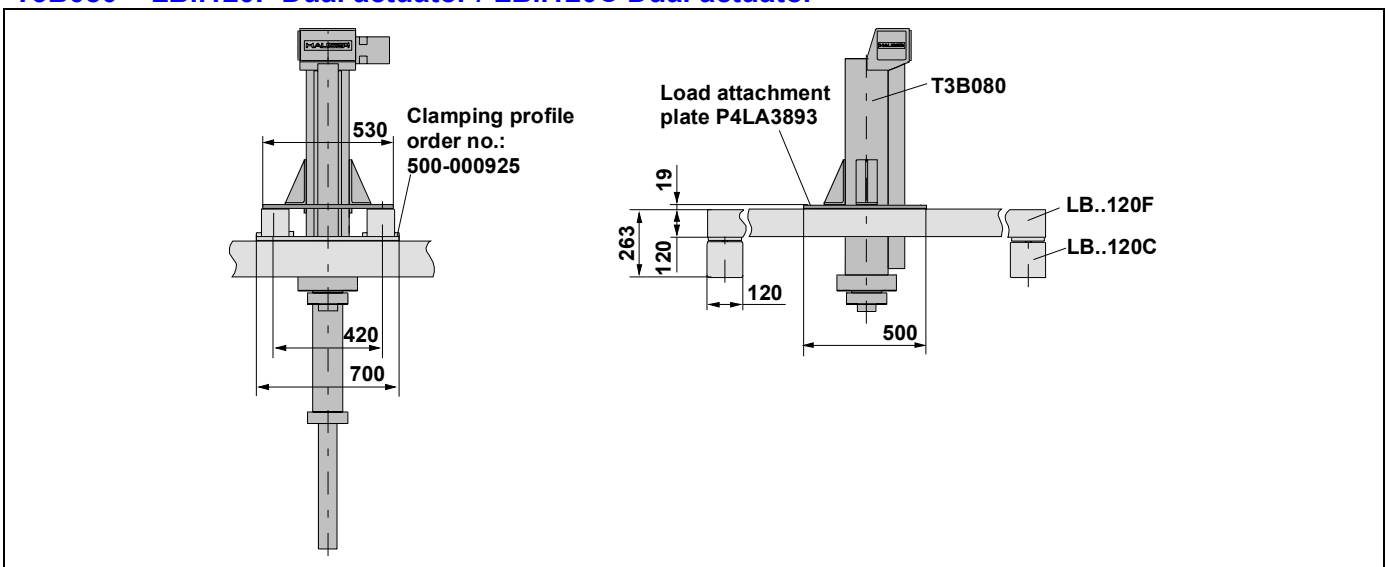

# HTR – Telescopic actuator with belt drive

## T3B080 – LB..120F Dual actuator / LB..180E Dual actuator

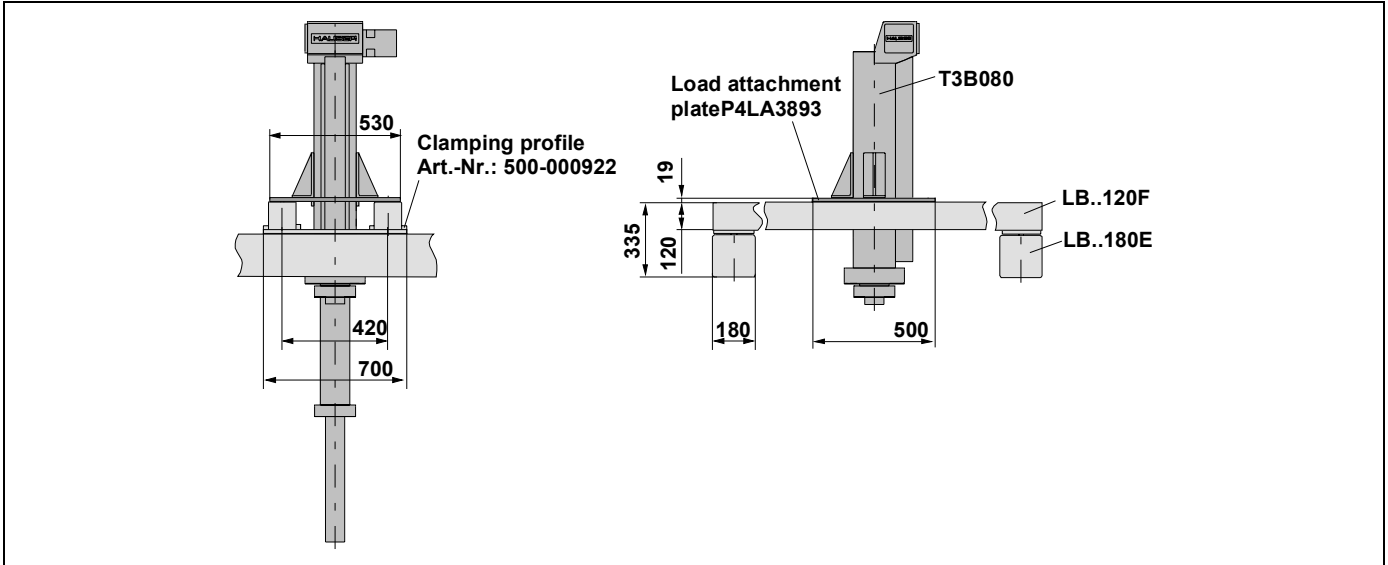

## T3B080 - LEB150F Dual actuator / LEB150C Dual actuator

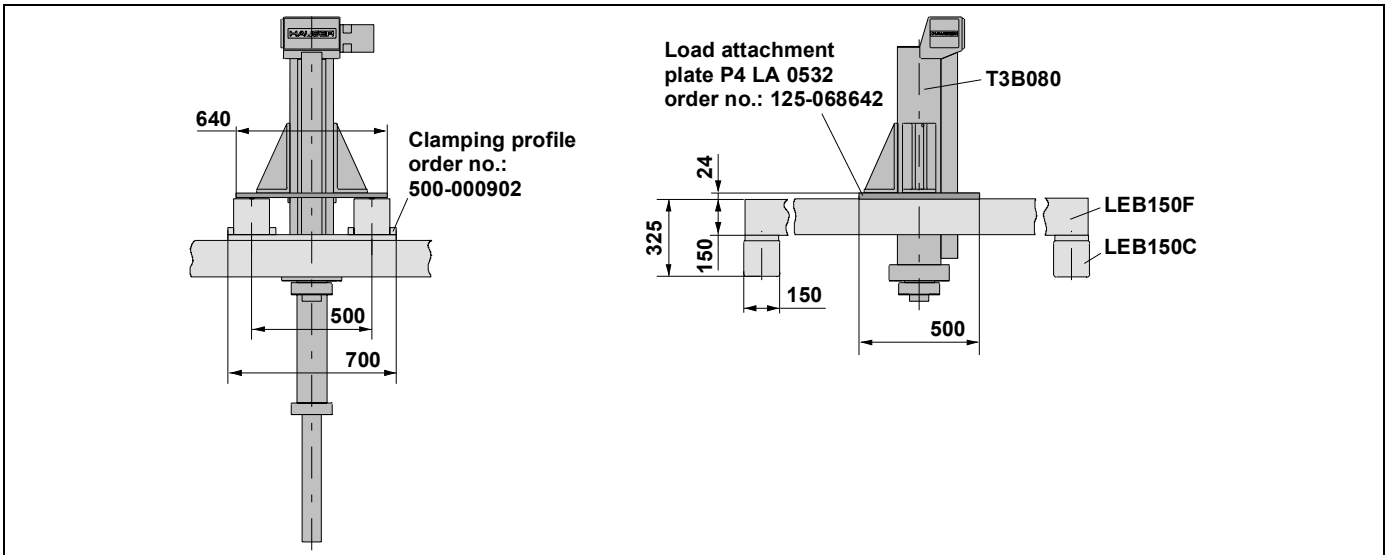

## T3B080 - LEB150D Dual actuator / LEB150C Dual actuator

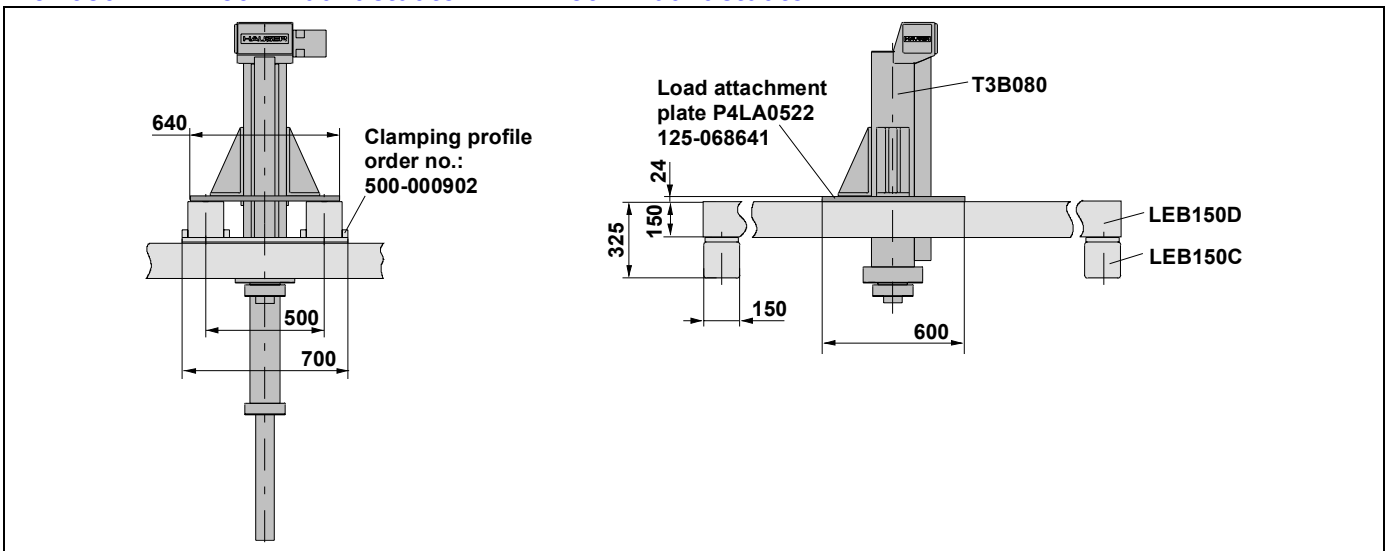

# HTR – Telescopic actuator with belt drive

## T3B080 - LEB150D Dual actuator / LB..180E Dual actuator

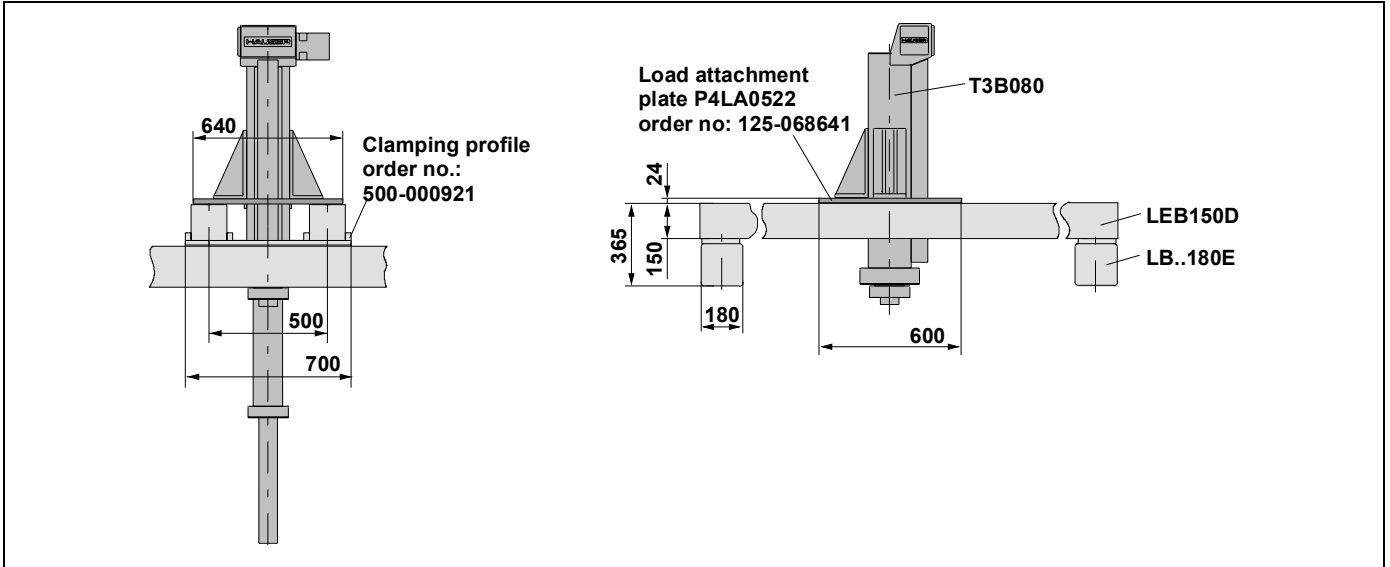

# HTR – Telescopic actuator with belt drive

## Order code

<b>HTR telescopic actuator</b>	<b>T</b>		<b>B</b>	<b>0</b>	<b>0</b>		<b>P</b>	<b>0</b>												
<b>Drive system</b>																				
Telescopic actuator	T																			
<b>Number of telescope sections</b>																				
3																				
4 (Special design T4B050 = 4 stage HTR)																				
<b>Type of drive</b>																				
Toothed belt																				
<b>Model size</b> (according to the cross section of the inner profile)																				
50mm																				
80mm																				
<b>Material version</b>																				
Standard																				N
VA stainless (on request)																				V
<b>Guide system</b>																				
Standard (plastic sheathed rollers)																				P
<b>Stroke</b>																				
Specify required stroke (in mm)																				0 n n n n
<b>Drive options</b> (for definition see picture below)																				
Prepared for gearbox to be fitted on the left																				D L
Prepared for gearbox to be fitted on the right																				D R
Extras (other drive versions)																				X X
<b>Gearbox flange</b>																				
P3 for T3B050																				A
P4 for T3B080 and T4B050																				B
PE4 for T3B050, T4B050																				Q
PE5 for T3B080																				R
Extras (others, not standard) (on request)																				X

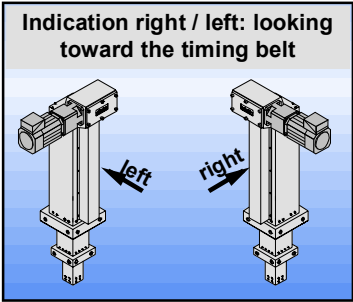

**Note:** The limit switch gearbox (→ page 35) must be ordered separately!

## HZR – Z-axis with belt drive

### HZR dynamic lifting actuator

Z-axis with belt drive - designed for vertical use



Subject to technical modifications. Data correct at time of printing.

#### Contents:

Features of the HZR .....	14
Construction of the HZR .....	15
Dimensions .....	16
Technical data.....	19
Force and torque capabilities .....	20
Combinations HZR - HLE/HPLA.....	22
Order code .....	29
Accessories .....	30
Cable carrier .....	30
Attachment of position sensors and accessories ...	32
Attachment variants for HZR position sensors .....	32
Mechanical limit switch for HZR.....	33
Electrical limit switch (initiator).....	33
Cylindrical limit switch for ZEB50.....	34
Tripping plate for HZR.....	35
Distribution box.....	36
Connection set for HZR50.....	37
T-nuts and bolts for HZR.....	37
Other accessories / software .....	38

#### Features of the HZR

- ◆ Available in 3 sizes:  
ZEB050, ZEB080 and ZEB100
- ◆ Can be combined with HLE and HPLA linear actuators in a modular system
- ◆ Withstands large side forces by means of a deflection-resistant aluminium profile, carried in a closed, generously-dimensioned cast housing.
- ◆ Backlash-free guidance by means of adjustable, plastic sheathed rollers mounted on roller bearings.
- ◆ High vertical forces up to 1500 N can be accommodated.
- ◆ Simple, non-critical installation and start up.
- ◆ Maintenance-free, low-noise PA sheathed rollers.
- ◆ Non-wearing and non-slip timing belt drive.

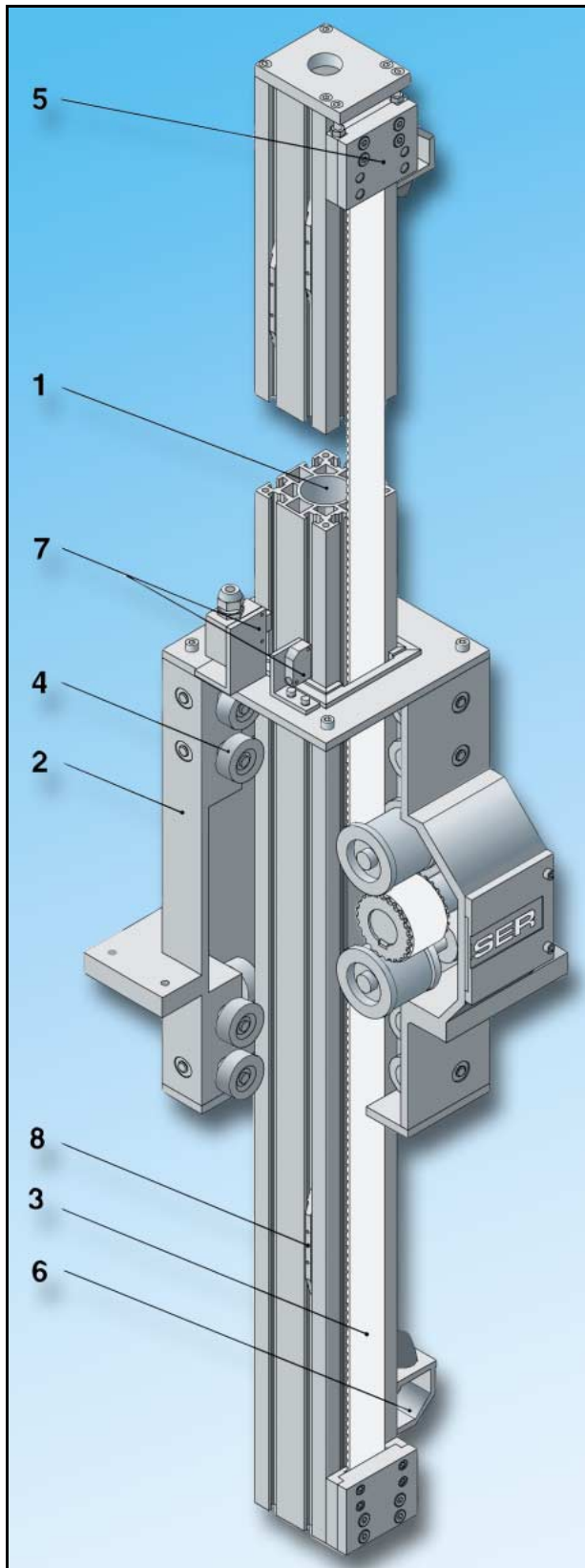
**Construction of the HZR****The profile (1)**

Light, compact and self-supporting construction made from a closed and therefore torsion-resistant aluminium profile. Available in the following cross-sections:

**50x50mm (ZEB050)**

**80x80mm (ZEB080)**

**100x100mm (ZEB100)**

On each of the three sides of the profile there are two (ZEB080 and ZEB100) resp. one (ZEB050) groove(s) for mounting tripping plates, limit stops and additional mechanical components. Cables can be fed downwards through the large opening in the centre of the profile. At the lower end of the profile, there are four screw threads for suspending loads.

**The housing (2)**

The stable cast housing with a closed frame structure can withstand very large side forces and bending moments resulting from horizontal acceleration for example. An integrated cast flange ensures a stable connection to other mechanical components, such as a dual actuator system using Parker linear actuators. The drive can be mounted on either side of the housing.

**The timing belt (3)**

High speeds and repeatability are guaranteed by a wide, slip-free timing belt drive, reinforced by steel tension cords. A wide area clamp ensures a secure connection between the timing belt and the carriage profile.

**The guide rollers (4)**

The latest type of plastic sheathed rollers mounted on roller bearings ensure low-friction running. They can be adjusted by means of eccentric bolts so that the profile (1) is backlash-free. Very high side forces and moments can be applied due to the large roller distances in the stable housing.

**The tensioning station (5)**

The tensioning station is easily accessible and is therefore easy to maintain and mount. It is used to set the required pretension of the timing belt.

**The limit stop (6)**

The mechanical limit stops consist of stable, closed aluminium brackets each with two damping rubber buffers. These can be moved freely along the profile grooves and can be mounted on any side of the profile (except the toothed belt side).

**The position sensors (7)**

Mechanical or inductive limit switches may optionally be mounted on the covers of the upper and lower sides of the HZR housing. A cylindrical limit switch (home sensor) may be optionally mounted on the right or on the left side of the ZEB050 housing.

**The tripping plate (8)**

The tripping plates are completely integrated into the profile grooves and can be continuously varied in position.

# HZR – Z-axis with belt drive

## Dimensions

### ZEB050

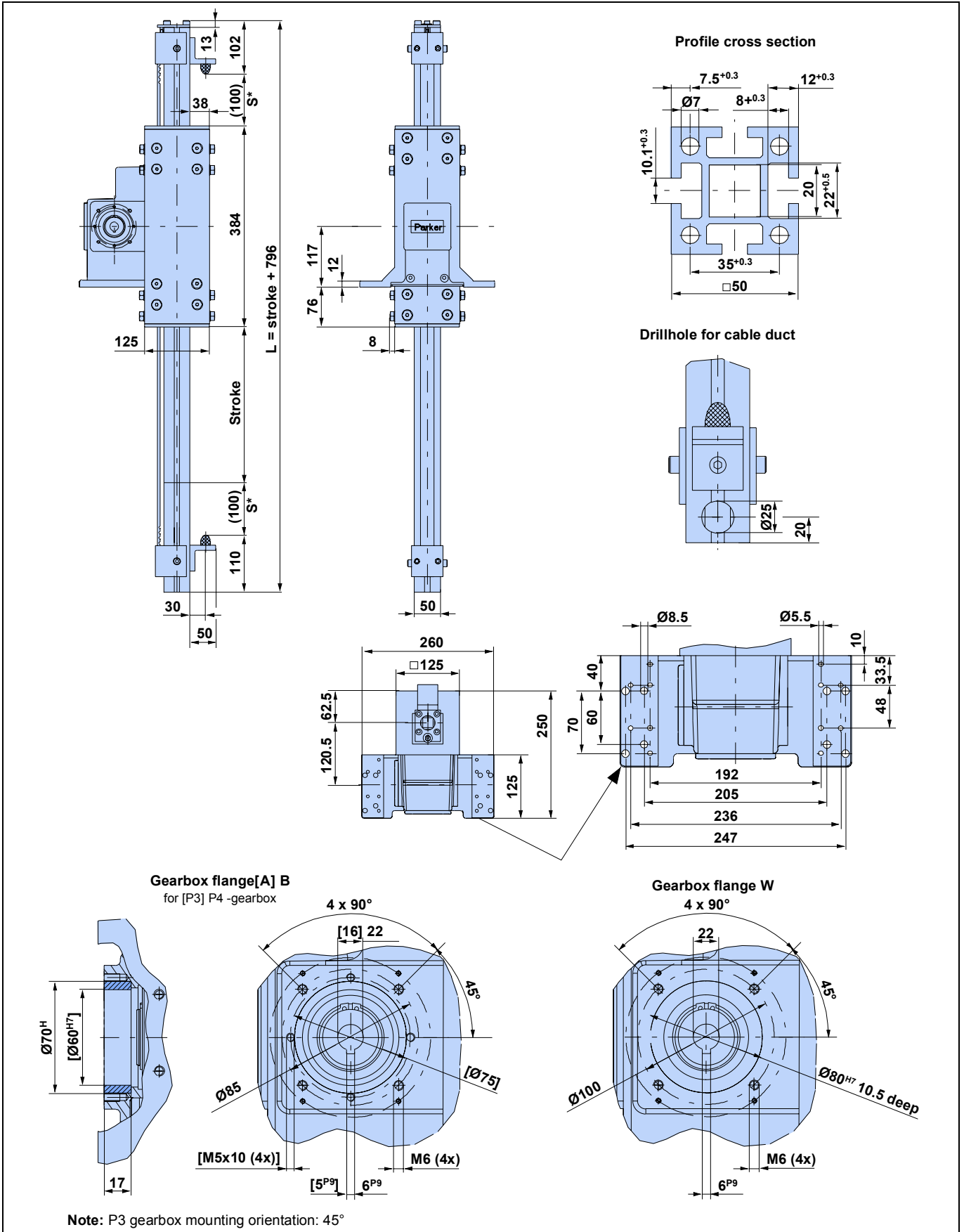



# HZR – Z-axis with belt drive

## ZEB080

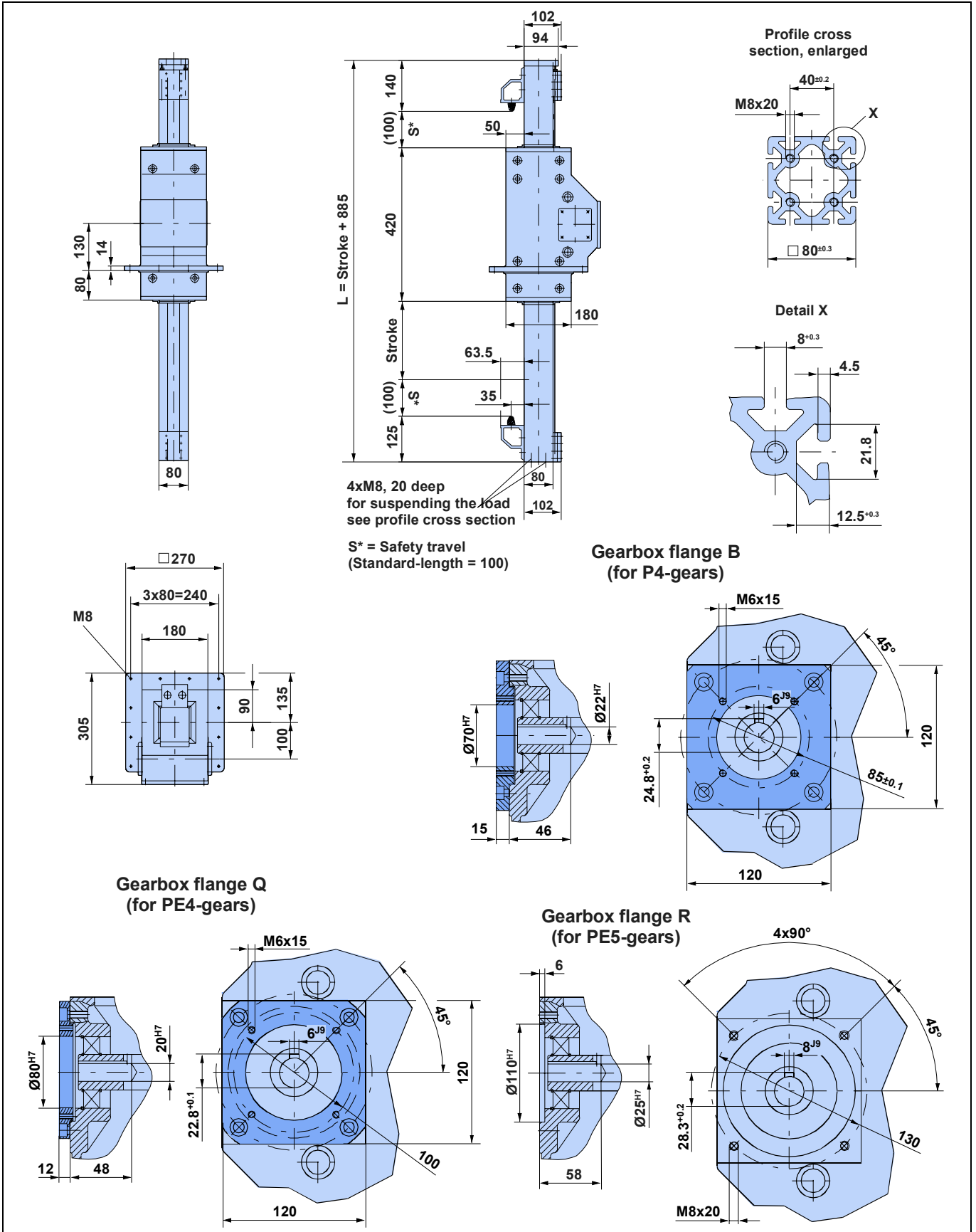

# HZR – Z-axis with belt drive

## ZEB100

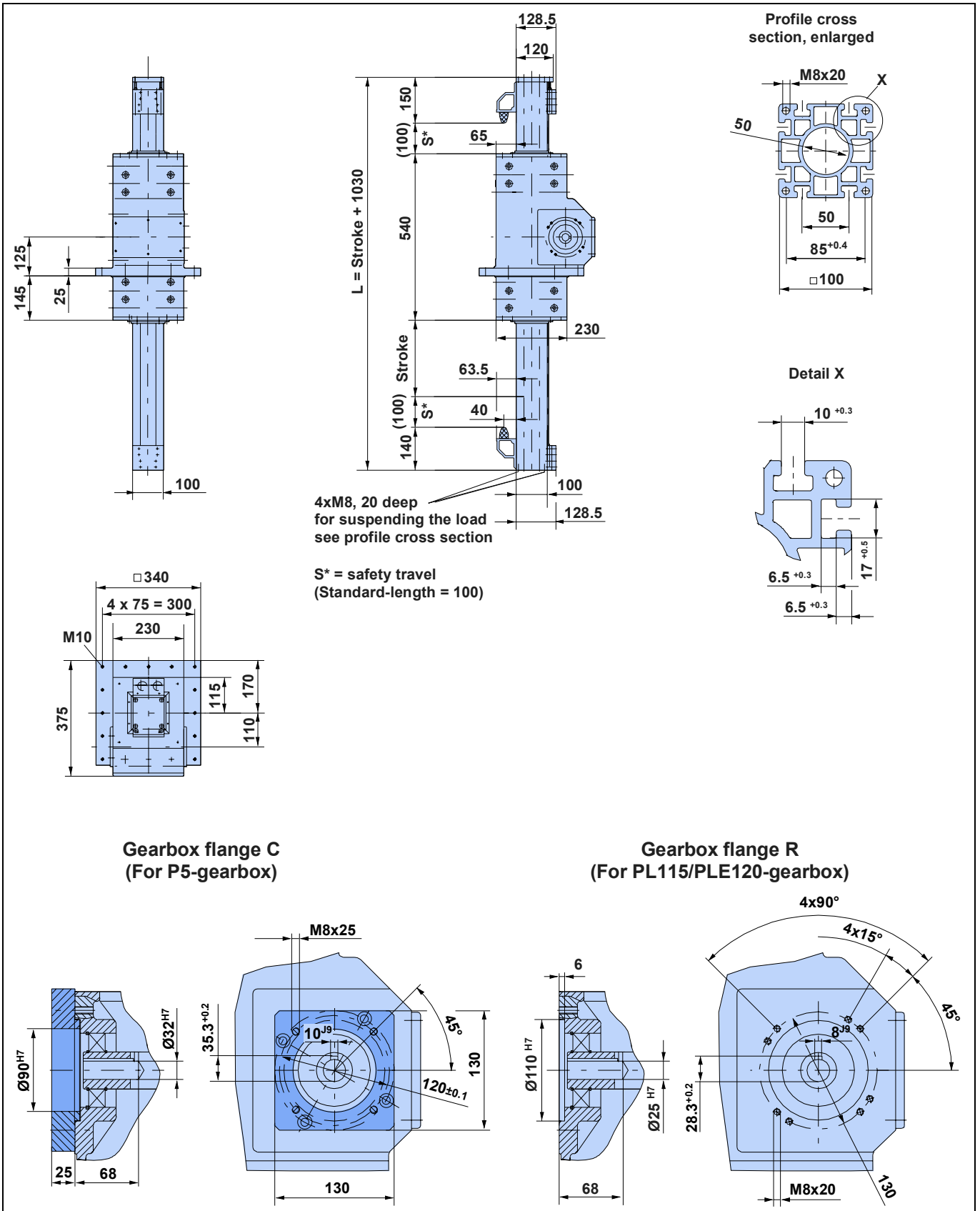

## HZR – Z-axis with belt drive

### Technical data

HZR size P: standard guiding; E: extended guiding <sup>3)</sup>	Unit	ZEB050		ZEB080	ZEB100
		P	E	P	P

### Weight and moment of inertia

Weight of basic unit without stroke	kg	12.4	14.3	30.7	50.2
Additional weight per metre	kg/m	2.9		6.4	9.8
Mass moment of inertia, related to the drive shaft, no stroke	kgcm <sup>2</sup>	40.8	41.2	153.7	209.3
Additional mass moment of inertia related to the drive shaft per metre of stroke	$\frac{\text{kgcm}^2}{\text{m}}$	25.31		96.3	147.7

### Travel paths and speeds

Maximum travel speed	m/s	5.0	5.0	5.0
Maximum travel path	mm	1500	1500	2000
Maximum permissible acceleration	m/s <sup>2</sup>	5	5	5

### Accuracy

Repeatability in one direction (according to DIN EN ISO 9283)	mm	±0.2	±0.2	±0.2
---	----	------	------	------

### Geometrical data

Cross section of moving profile	mm x mm	50 x 50	80 x 80	100 x 100
Moment of inertia $I_x = I_y$	cm <sup>4</sup>	29.9	174.7	392
Section modulus $W_x = W_y$	cm <sup>3</sup>	29.9	43.6	78.4

### Pulley and toothed belt data, torques and forces

Travel distance per revolution	mm/rev	180	240	240
Pulley diameter	mm	57.300	76.394	76.394
Toothed belt width/pitch:	mm	25 / 10	32 / 10	50 / 10
Nominal drive torque	Nm	13	28.6	57.3
Maximum drive torque	Nm	47	108	168
Nominal thrust force (effective load)	N	450	750	1500
Maximum thrust force	N	1654	2827	4400

#### Please contact us if your application has the following requirements:

1. Speeds and acceleration greater than the data given above
2. Travel greater than the data given above
3. Nominal belt thrust force greater than the data given above. Increased timing belt tension is required.
4. Fitting position horizontal or upside down.



Technical data issued 03/02, safety factor taken into consideration  $S=1$ . Data applies for a temperature range of between -10°C and +40°C. The technical data applies under standard conditions and only for the individually specified operating mode and nature of load. In the case of compound loads, it must be verified in accordance with the laws of physics and technical standards, whether single data have to be reduced. Please contact us in the case of doubt.

<sup>3)</sup> Extended guiding with 16 additional rollers in the housing

# HZR – Z-axis with belt drive

## Force and torque capabilities

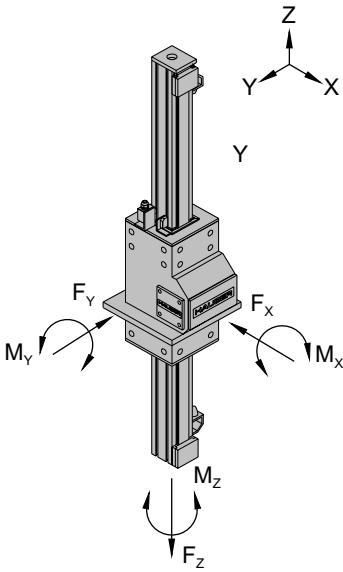

The forces and torques the rollers and timing belt are capable of transferring are speed-dependent.

The curves show the maximum load-bearing capacity of the rollers in one direction of force or torque. If several loads are applied in different directions, the values specified in the curves **must be derated**, i.e. the load or speed should be reduced if necessary.

For precise dimensioning, our software "DimAxes" is available (Refer to "Other accessories / software", page 38)

**Note:** The forces  $F_x$  resp.  $F_y$  arise as forces of inertia if the HZR itself is mounted on a linear actuator and is accelerated!

Actuator type	$F_x, F_y, F_z$	$M_x, M_y, M_z$
ZEB050		
ZEB080		

# HZR – Z-axis with belt drive

Actuator type	$F_x, F_y, F_z$	$M_x, M_y, M_z$
ZEB100		

## Roller load bearing capacity on the basis of a permanent side load

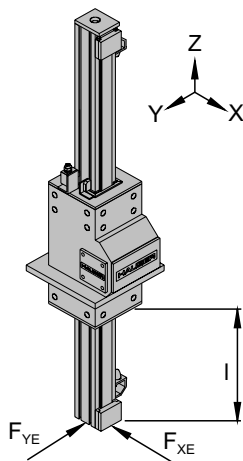

ZEB050

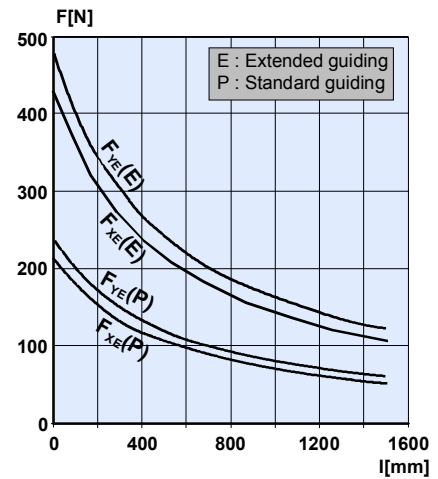

ZEB080

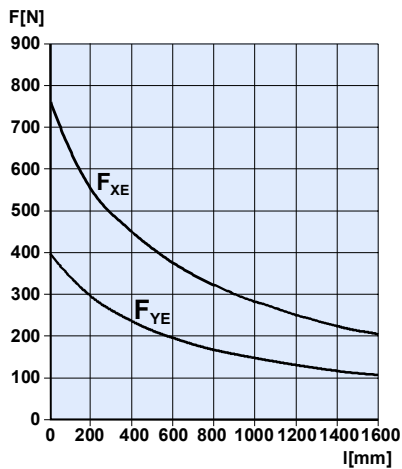

ZEB100

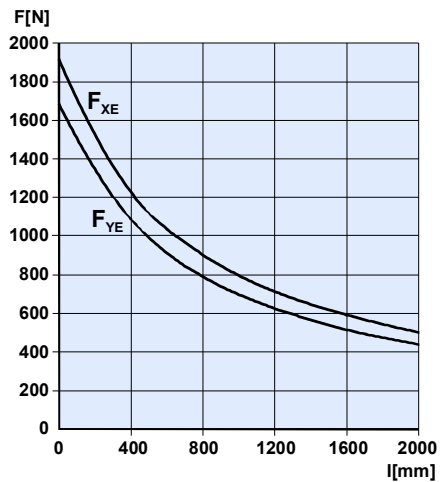

## HZR – Z-axis with belt drive

### Combinations HZR - HLE/HPLA

#### Overview on all possible combinations

ZEB050 with HPLA/HLE	See page
ZEB050 – LB..080S Dual actuator / LB..080E Dual actuator	22
ZEB050 – LB..080S Dual actuator / LEB100E Dual actuator	23
ZEB050 - LEB100S Dual actuator / LEB100E Dual actuator	23
ZEB050 - LB..120S Single actuator	24
ZEB080 with HPLA/HLE	See page
ZEB080 - LEB100F Dual actuator / LEB100E Dual actuator	24
ZEB080 - LEB100F Dual actuator / LB..120E Dual actuator	24
ZEB080 - LEB100F Dual actuator / LEB150E Dual actuator	25
ZEB080 – LB..120F Dual actuator / LB..120E Dual actuator	25
ZEB080 – LB..120F Dual actuator / LEB150E Dual actuator	25
ZEB080 – LB..120F Dual actuator / LB..180E Dual actuator	26
ZEB080 - LEB150F Dual actuator / LEB150C Dual actuator	26
ZEB100 with HPLA/HLE	See page
ZEB100 - LEB100F Dual actuator / LEB150E Dual actuator	26
ZEB100 – LB..120F Dual actuator / LB..120C Dual actuator	27
ZEB100 – LB..120F Dual actuator / LEB150C Dual actuator	27
ZEB100 – LB..120F Dual actuator / LB..180E Dual actuator	27
ZEB100 - LEB150F Dual actuator / LEB150C Dual actuator	28
ZEB100 - LEB150F Dual actuator / LB..180E Dual actuator	28
ZEB100 – LB..180F Dual actuator / LB..180E Dual actuator	28

#### ZEB050 – LB..080S Dual actuator / LB..080E Dual actuator

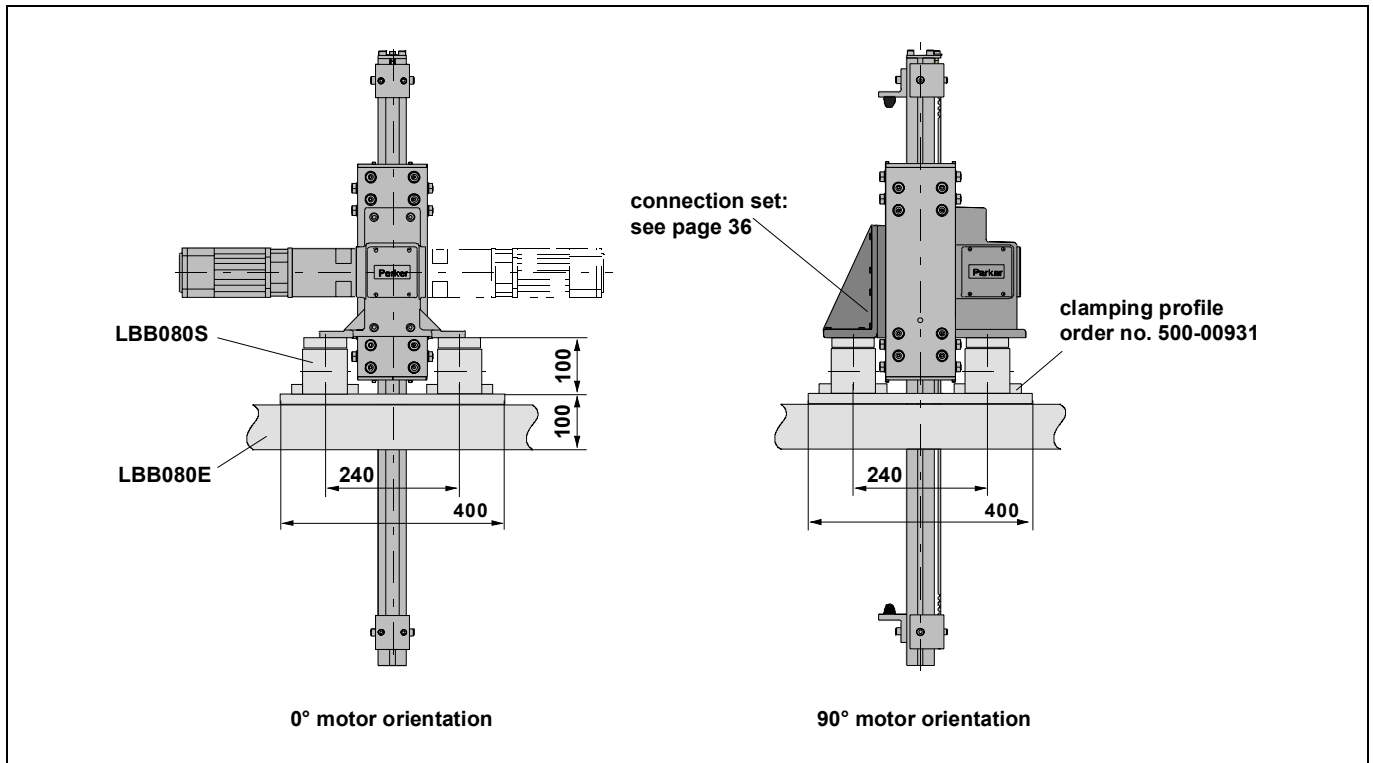

# HZR – Z-axis with belt drive

## ZEB050 – LB..080S Dual actuator / LEB100E Dual actuator

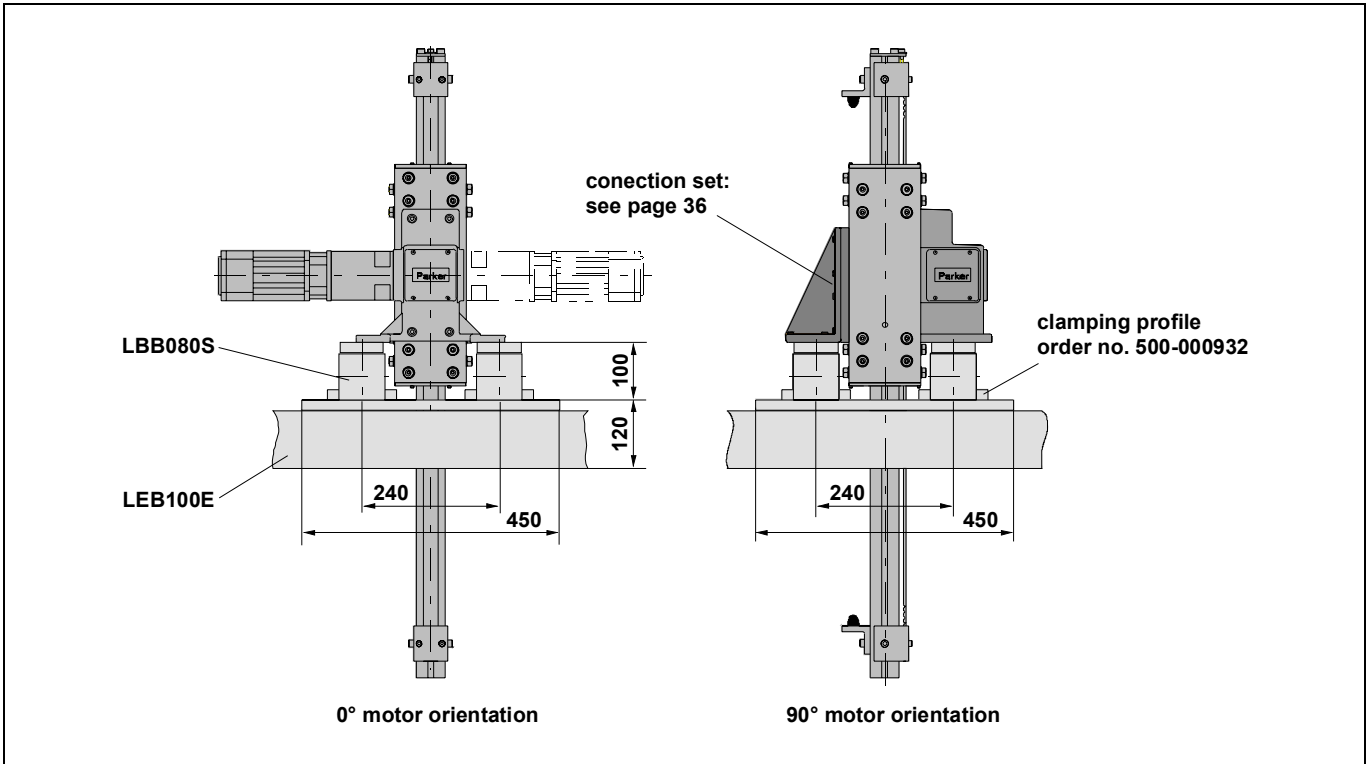

## ZEB050 - LEB100S Dual actuator / LEB100E Dual actuator

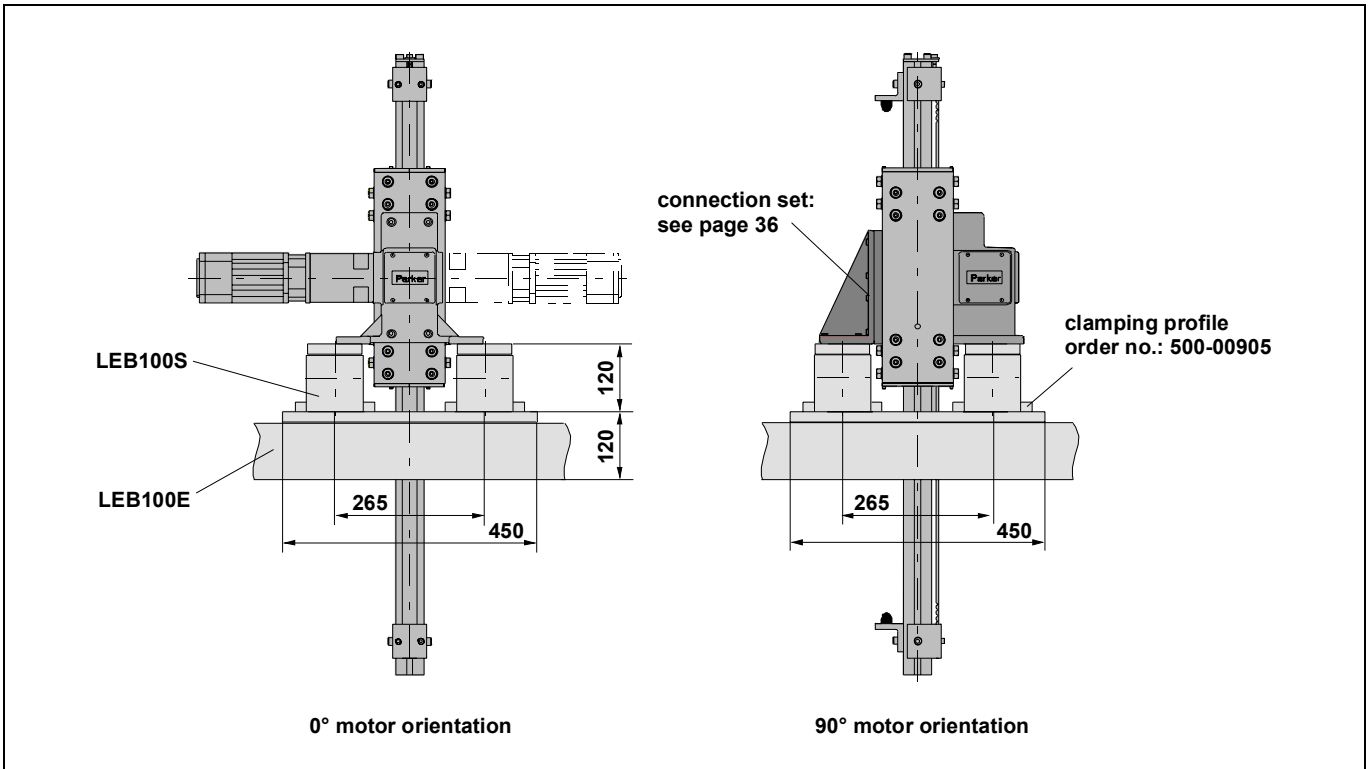

# HZR – Z-axis with belt drive

## ZEB050 - LB..120S Single actuator

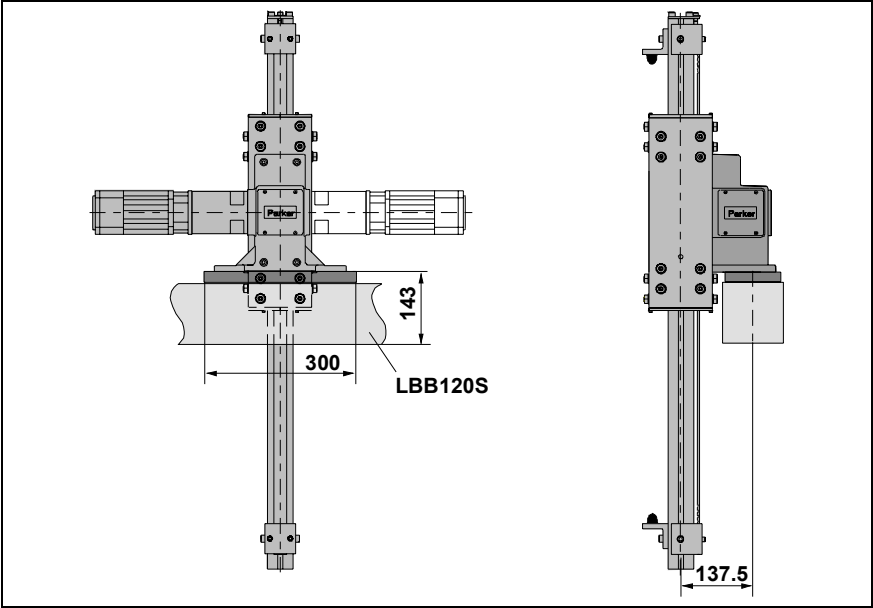

Please make sure you use a robust substructure for this actuator combination. The HPLA120 must be supported in regular, relatively small intervals.

If you use a standard carriage (length 300mm – as shown in the drawing) only the HPLA with steel roller guidance may be used.

If you use an extended carriage (length 500mm), a guiding with plastic sheathed rollers is sufficient.

## ZEB080 - LEB100F Dual actuator / LEB100E Dual actuator

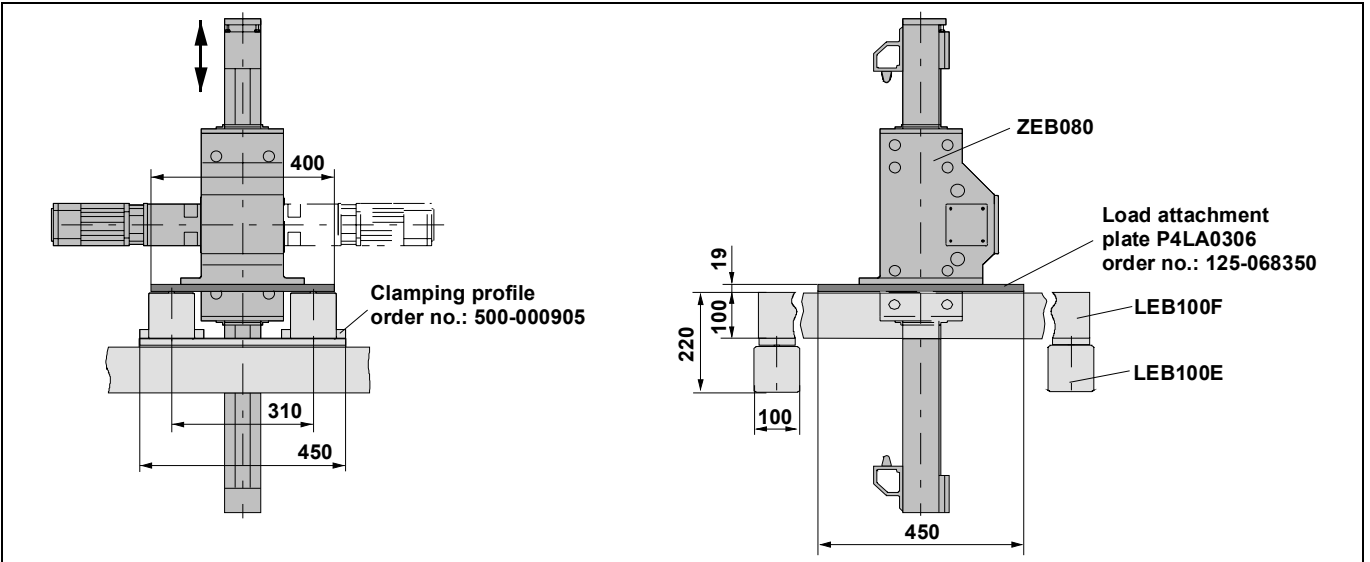

## ZEB080 - LEB100F Dual actuator / LB..120E Dual actuator

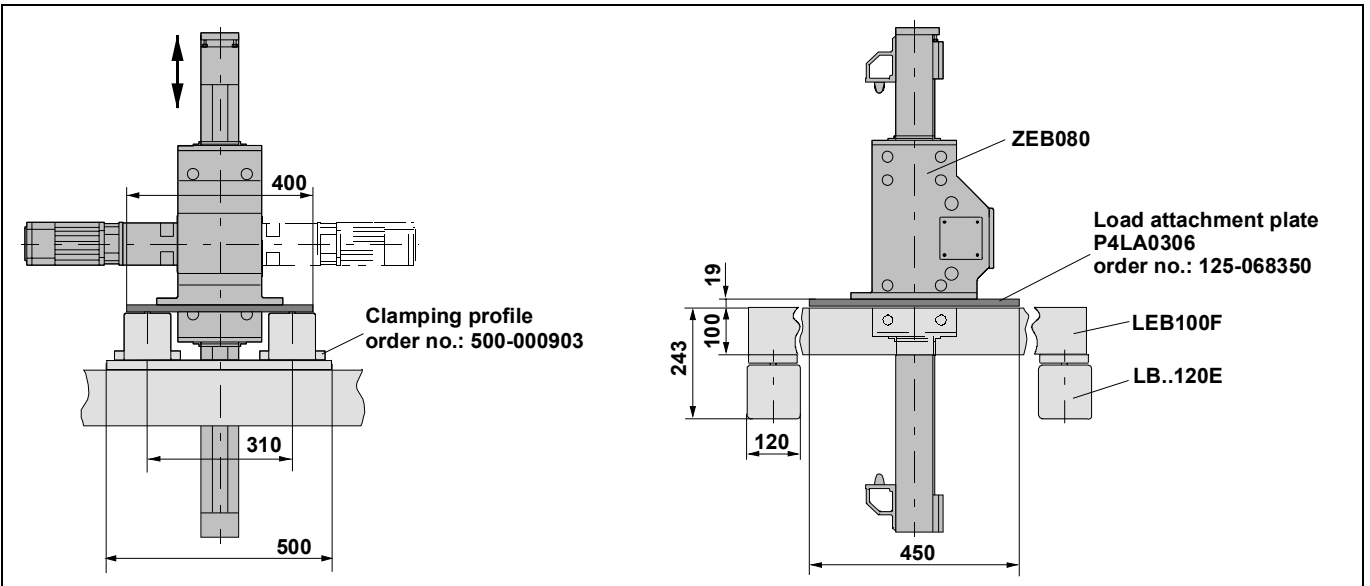



# HZR – Z-axis with belt drive

## ZEB080 - LEB100F Dual actuator / LEB150E Dual actuator

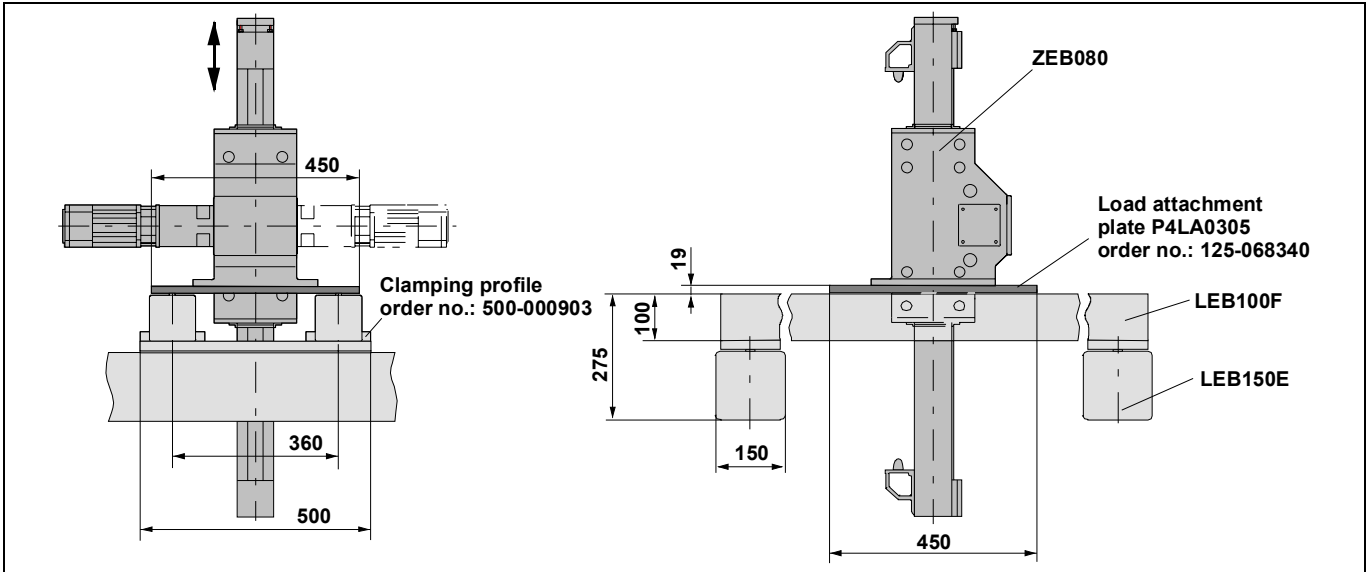

## ZEB080 – LB..120F Dual actuator / LB..120E Dual actuator

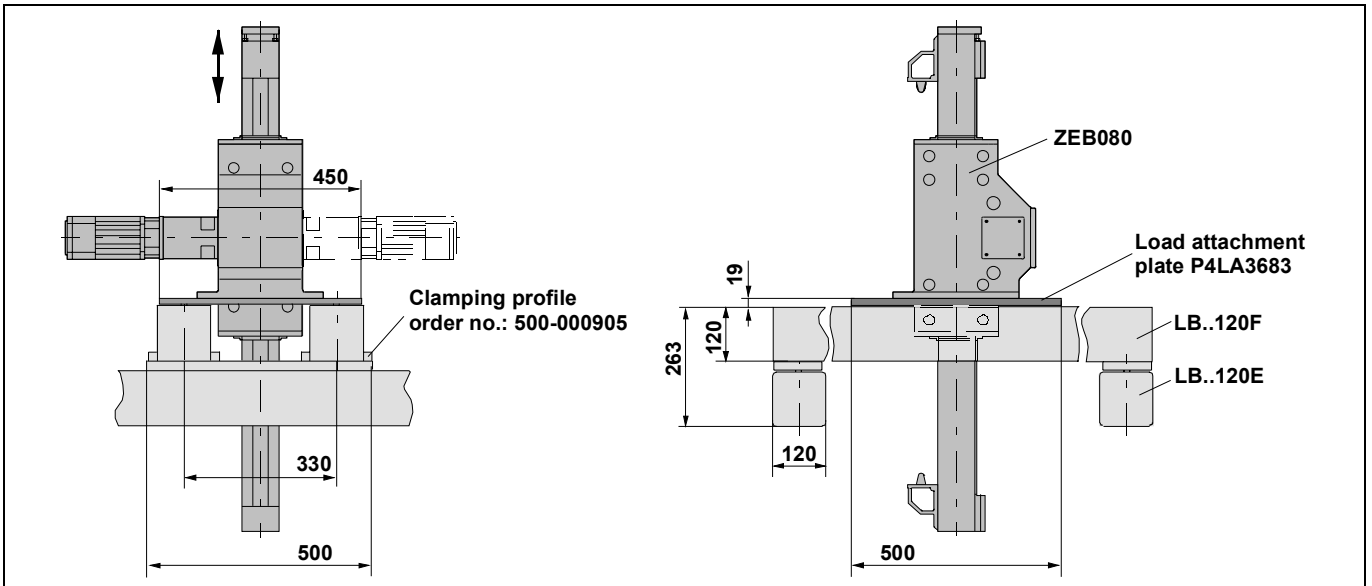

## ZEB080 – LB..120F Dual actuator / LEB150E Dual actuator

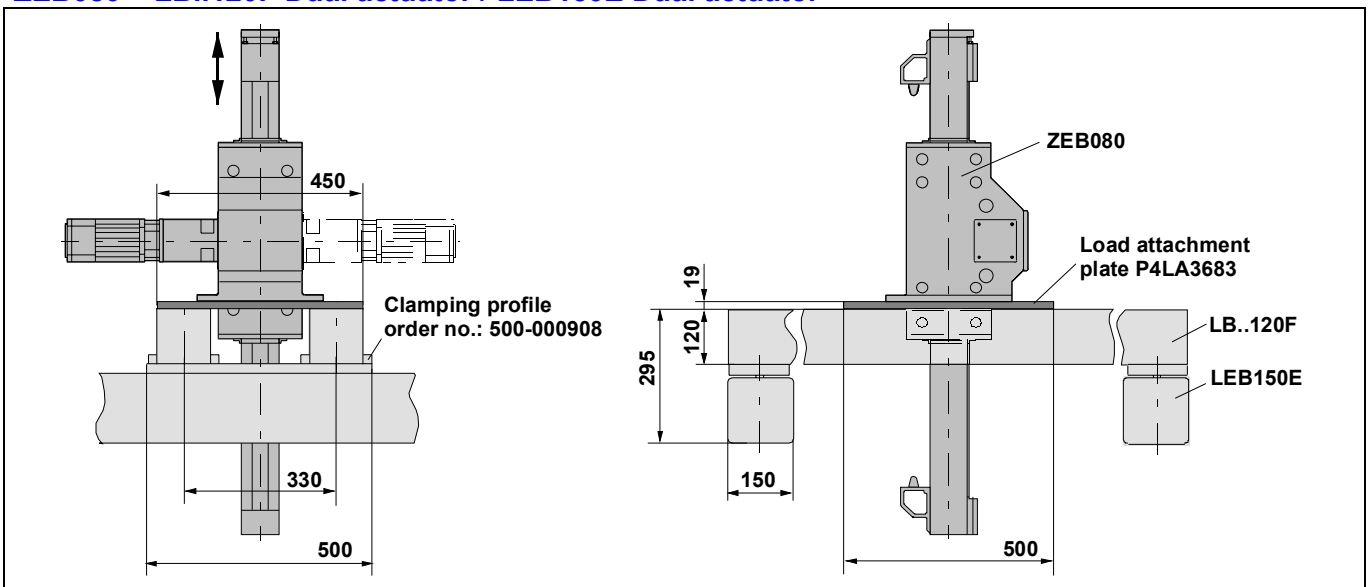

# HZR – Z-axis with belt drive

## ZEB080 – LB..120F Dual actuator / LB..180E Dual actuator

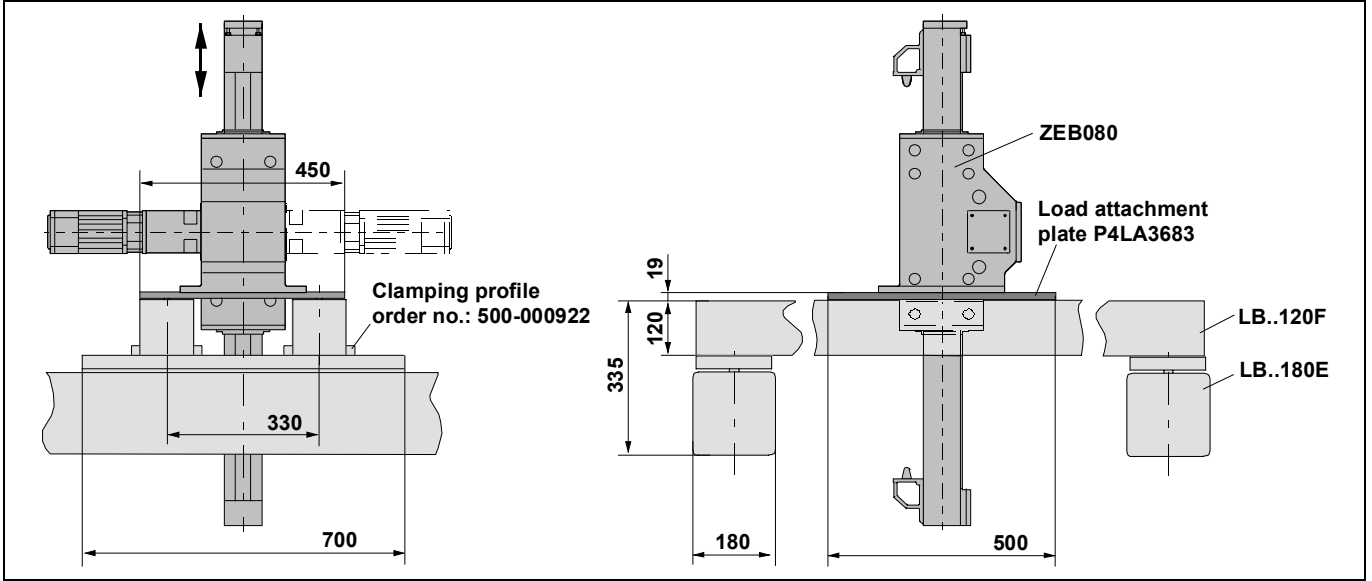

## ZEB080 - LEB150F Dual actuator / LEB150C Dual actuator

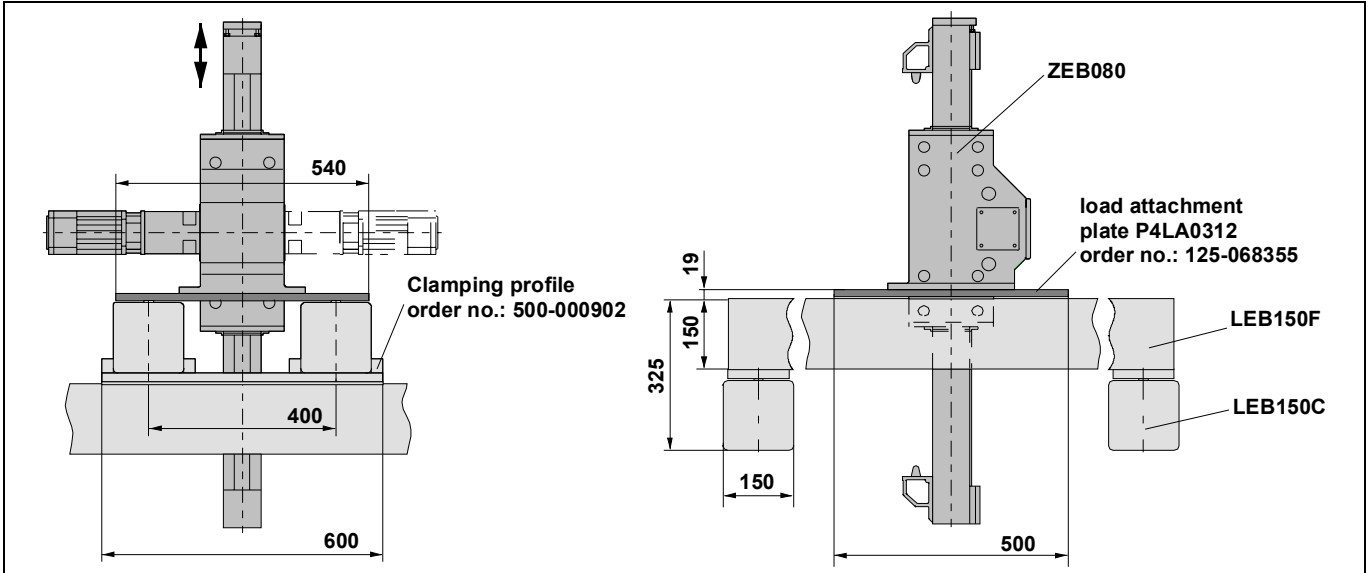

## ZEB100 - LEB100F Dual actuator / LEB150E Dual actuator

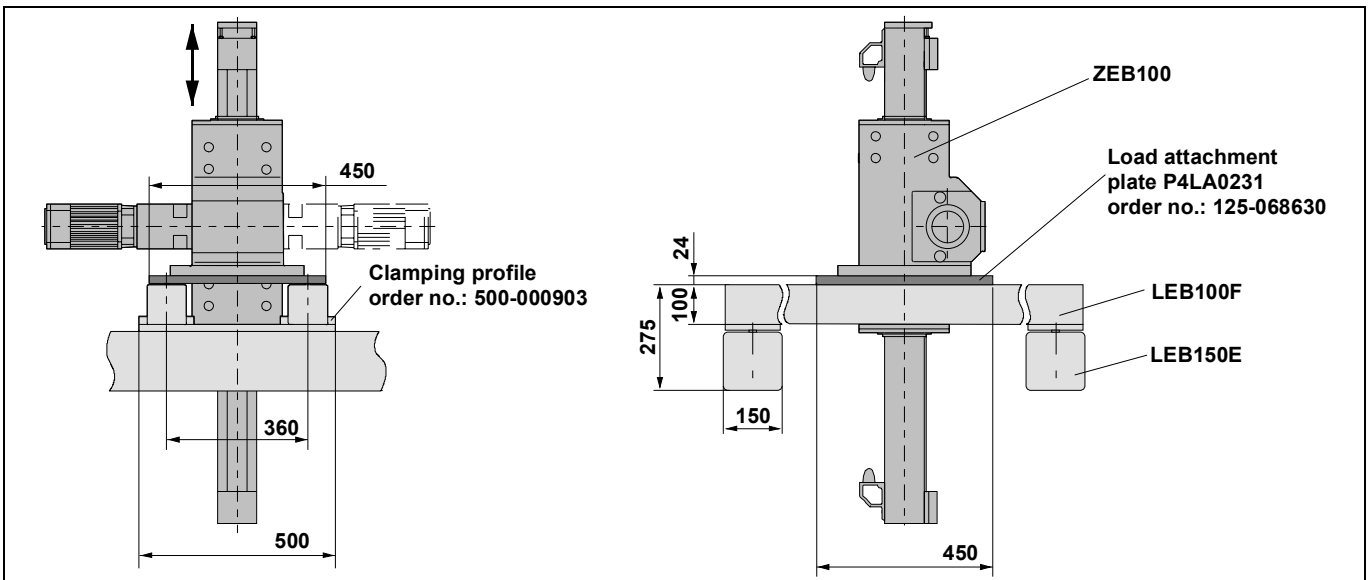

# HZR – Z-axis with belt drive

## ZEB100 – LB..120F Dual actuator / LB..120C Dual actuator

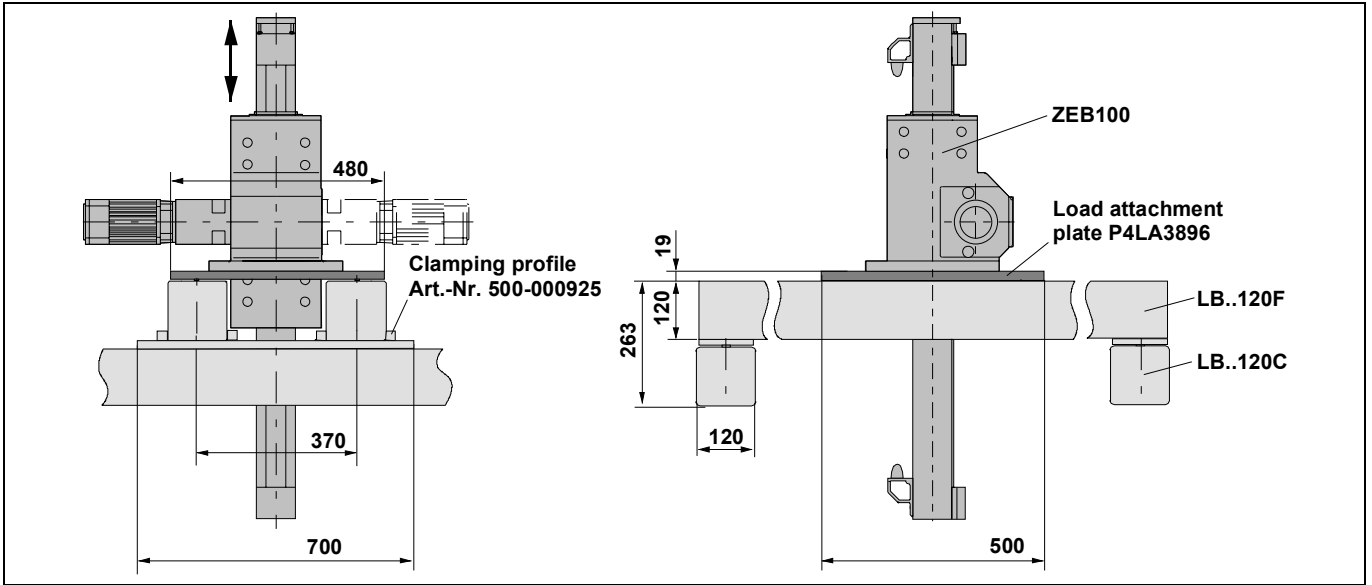

## ZEB100 – LB..120F Dual actuator / LEB150C Dual actuator

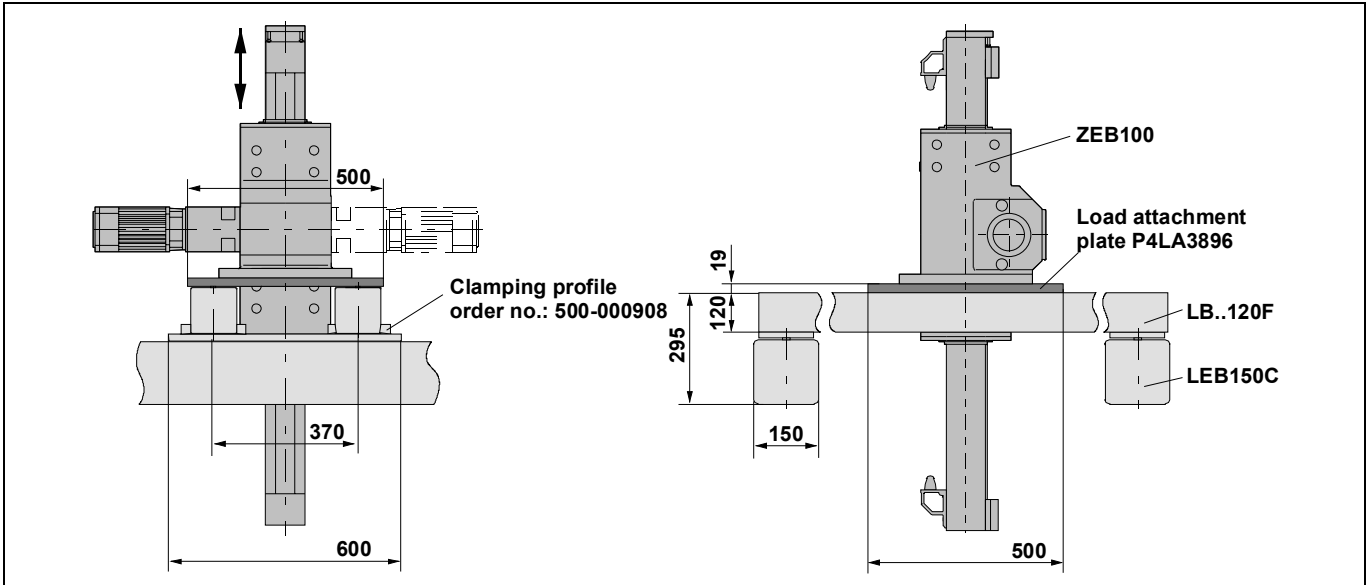

## ZEB100 – LB..120F Dual actuator / LB..180E Dual actuator

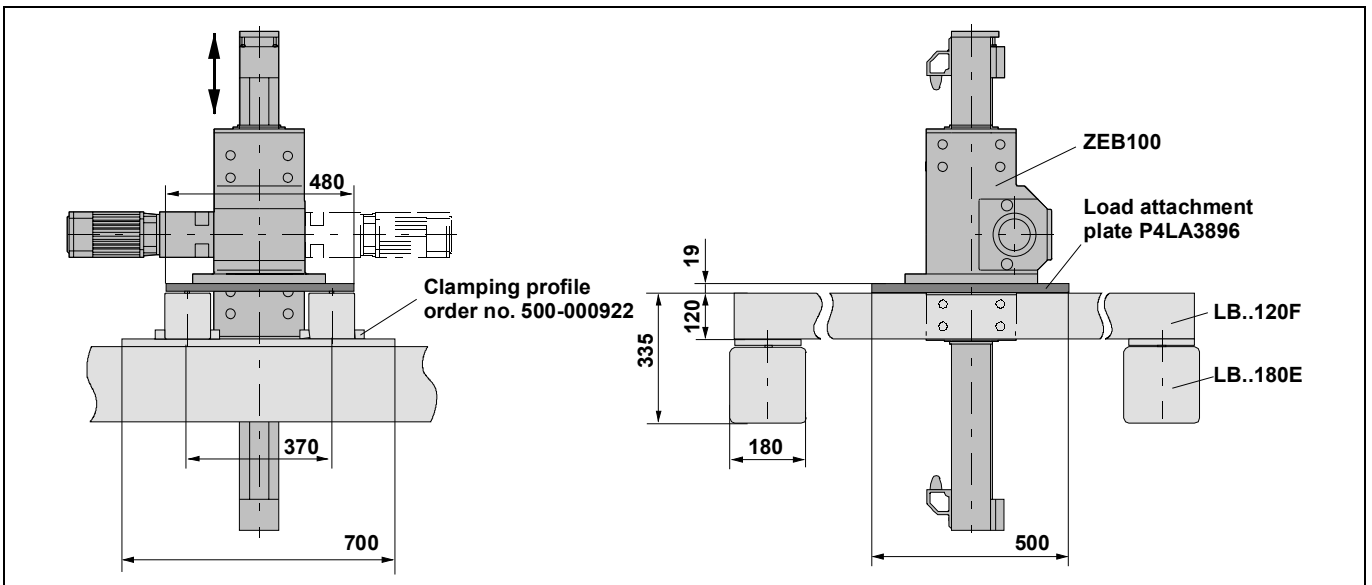

# HZR – Z-axis with belt drive

## ZEB100 - LEB150F Dual actuator / LEB150C Dual actuator

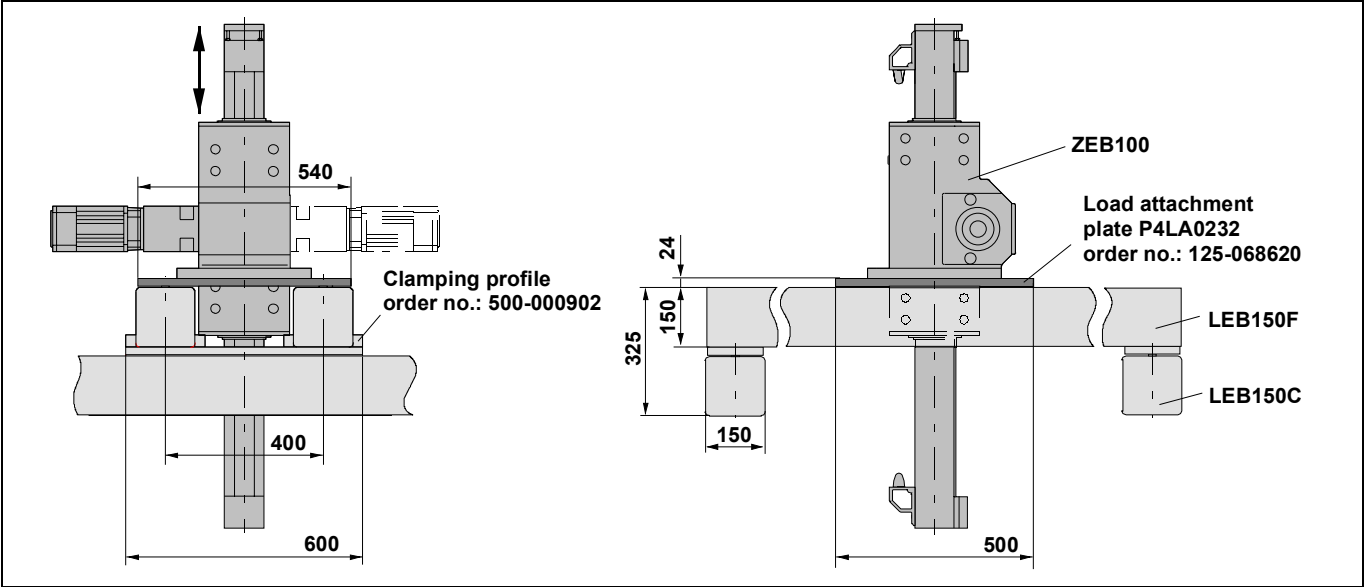

## ZEB100 - LEB150F Dual actuator / LB..180E Dual actuator

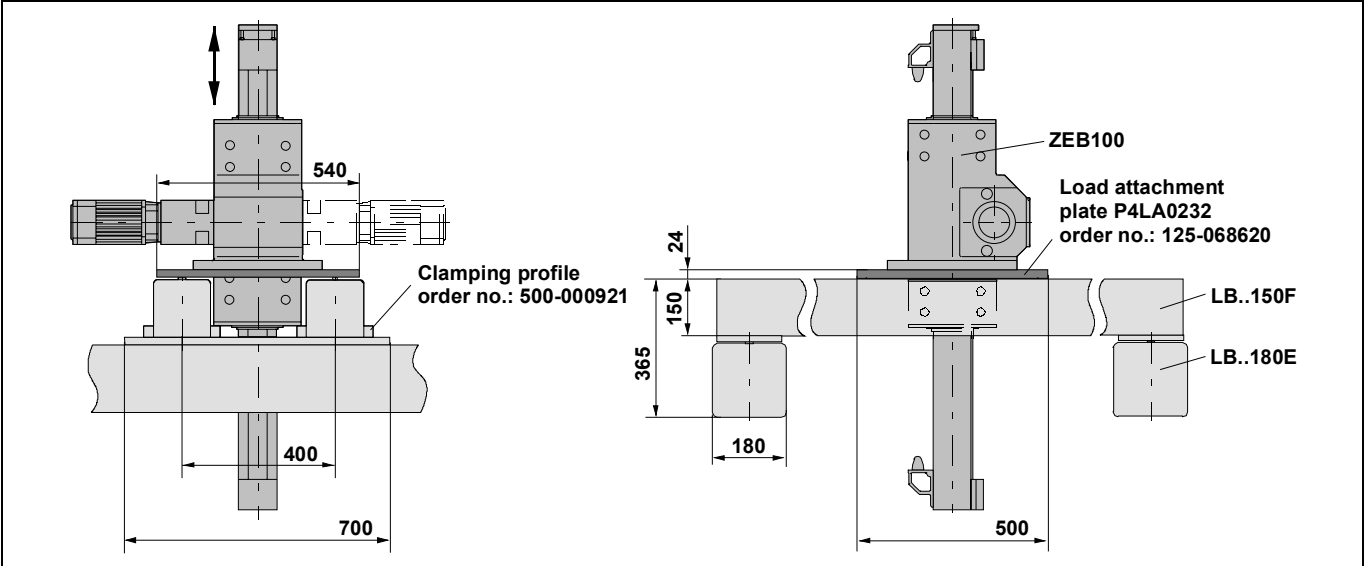

## ZEB100 – LB..180F Dual actuator / LB..180E Dual actuator

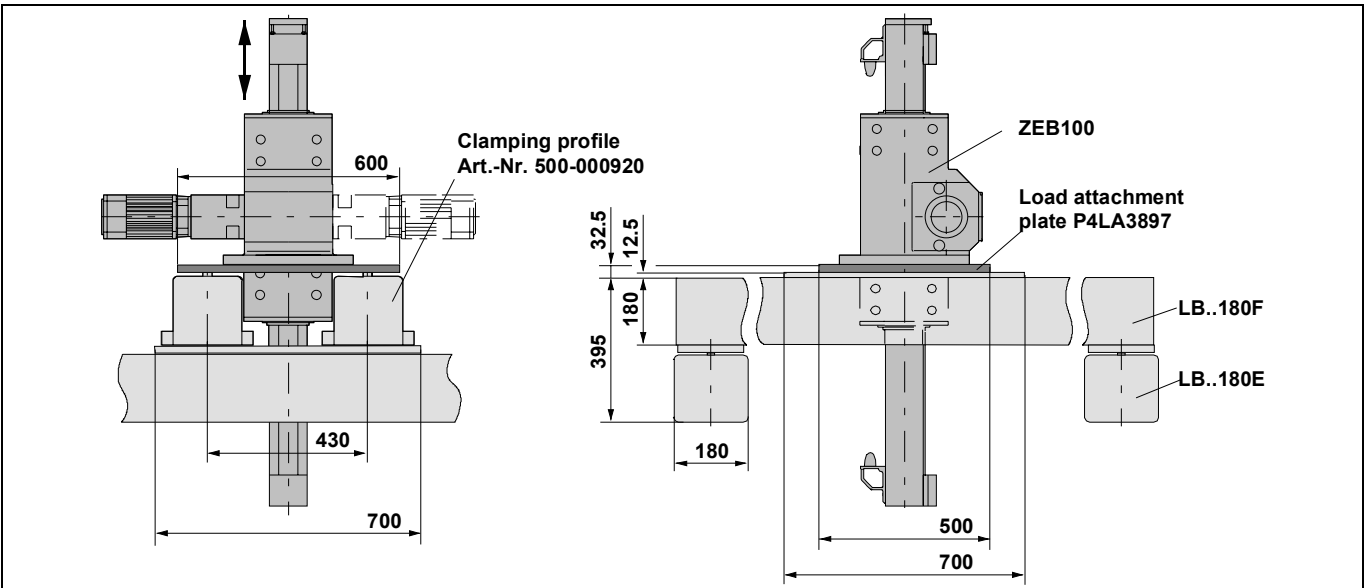

# HZR – Z-axis with belt drive

## Order code

Z-axis HZR	Z	E	B	0	P	0						
<b>Drive system</b>												
Z-axis	Z											
<b>Series</b>												
HZR	E											
<b>Type of drive</b>												
Timing belt	B											
<b>Profile cross section</b>												
050mm				0	5	0						
080mm				0	8	0						
100mm				1	0	0						
<b>Material version</b>												
Standard											N	
VA corrosion resistant											V	
<b>Guide system</b>												
Standard											P	
Extended guide with 16 additional rollers - only for ZEB050!											E	
<b>Stroke</b>												
Specify required stroke (in mm)						0	n	n	n	n	n	
<b>Drive options</b> (for definition of on right / on left: see picture below)												
Prepared for gearbox to be fitted on the left											D	L
Prepared for gearbox to be fitted on the right											D	R
Extras (other drive versions)											X	X
<b>Gearbox flange</b>												
P3 for ZEB050											A	
P4 for ZEB080, ZEB050											B	
P5 for ZEB100											C	
Lenze 52.308.04 for ZEB080 / Lenze 52.308.05 for ZEB100											L	
PE4 for ZEB080											Q	
PE5 for ZEB100 / ZEB080											R	
Flange for gearbox with fitting edge Ø80, pitch diameter Ø100, shaft diameter Ø22 and shaft length up to 40mm for ZEB050											W	
Extras (others, not standard) (on request)											X	

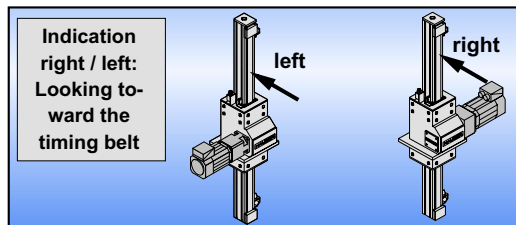

## Accessories

### Cable carrier

A cable carrier is needed when making power connections to moving elements. The cable carrier chain consists of glass fibre reinforced polyamide, and the support profile is made of aluminium. The process for fully determining the dimensions of a cable carrier is very complex. The examples listed below represent simple applications, but more data will normally be required when the situation is less straightforward. If the application you are running is more demanding, please contact us.

#### HZR with cable carrier type 0450.21 (ZEB050) resp. type 0450.41 (ZEB080 and ZEB100)

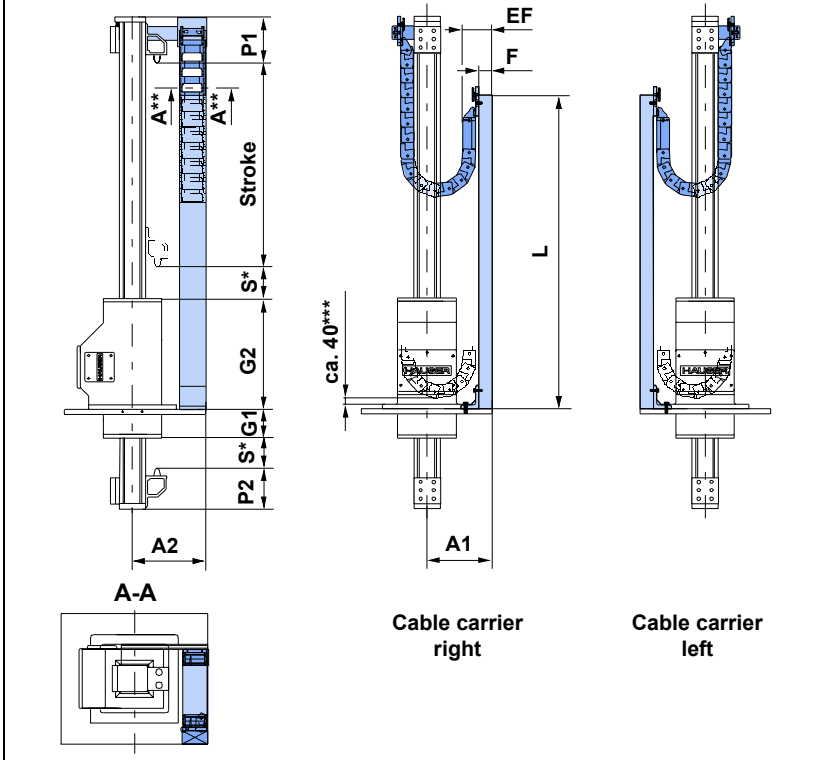

- S\***: safety travel (standard length 100mm)
- \*\*** for cross section A - A refer to page 31
- \*\*\*** remaining maximum distance to HZR flange if the actuator is driven on buffer.

#### Chain length for ZEB050:

$$L_K = \frac{\text{Stroke} + 2 \cdot \text{Safety travel}}{2} \quad 400$$

#### Chain length for ZEB080:

$$L_K = \frac{\text{Stroke} + 2 \cdot \text{Safety travel}}{2} \quad 555$$

#### Chain length for ZEB100:

$$L_K = \frac{\text{Stroke} + 2 \cdot \text{Safety travel}}{2} \quad 630$$

round chain length to a pitch of 45mm

→ example see below

Type	A1	A2	G1	G2	P1	P2	S	F	EF	L
ZEB050	63	143	87	297	102	110	100	6	46	$L = (\text{Stroke} + 2S) / 2 + 150$
ZEB080	200	225	80	340	140	125	100	40	90	$L = (\text{Stroke} + 2S) / 2 + 350$
ZEB100	200	255	145	395	150	140	100	40	90	$L = (\text{Stroke} + 2S) / 2 + 350$

#### Example for calculating the chain length

The chain length for a ZEB080 with a 800mm stroke and a standard safety travel of 100mm is calculated as follows:

$$L_K = \frac{800 + 200}{2} + 555 = 1055$$

This is the theoretical chain length required for driving a stroke plus safety travel. The chain is made up of parts each measuring 45mm. The chain length must therefore be rounded up to the next whole number divisible by 45:

$$L_K = \frac{1055}{45} = 23.44$$

The number of chain parts must be rounded up to the next whole number (24). The chain length to be ordered is:

$$L_K = 24 \cdot 45 = 1080$$

In this case you would need to order a chain with 24 parts and a length of 1080mm for your application.



Cable carriers for the telescopic HTR must be planned individually for each application.

# Accessories HTR and HZR

## Dimensions for the cable carrier chain

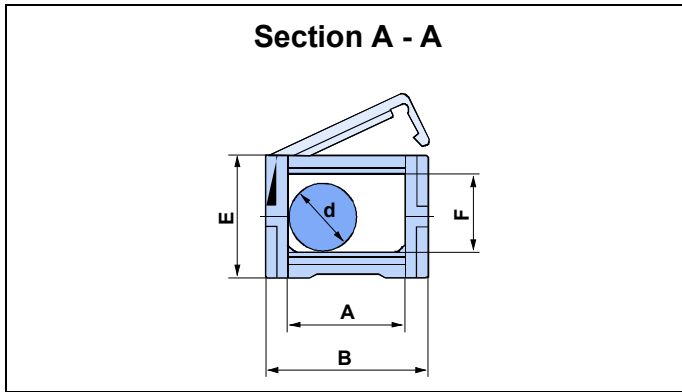

Actuator type	Chain type	A	B	E	F	d max.
ZEB050	0450.21 KR52	38	54	40	24	22
ZEB080 / ZEB100	0450.41 KR94	58	74	40	24	22

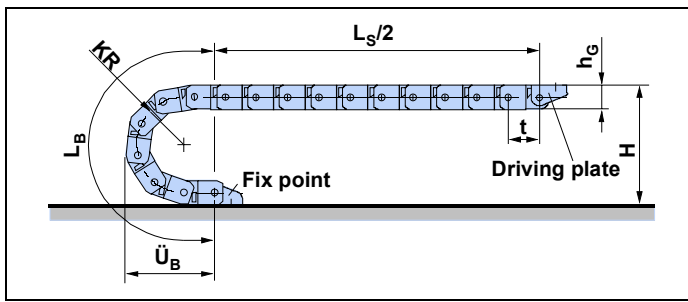

Actuator type	Chain type	Bending radius KR	Pitch t	Height hG	Curve length LB	Curve protrusion UB	Connection height Hmin (= 2KR+hg)	Own chain weight kg/m
ZEB050	0.450.21	52	45	40	254	117	144	0.75
ZEB080/ZEB100	0.450.41	94	45	40	386	159	228	0.85

## Guidelines for using cable carriers



Use only electrical cables which are suitable for use in cable carriers. Hose lines should be highly flexible and should only extend or shorten slightly under pressure. Weight should be distributed across the cable track as evenly as possible. Cables must not be twisted when routed in the cable carrier and should be routed next to one another and as loosely as possible.

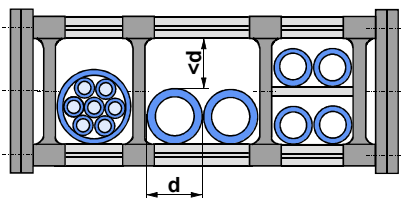

Avoid laying several lines on top of each other and laying lines of different diameters directly next to one another. If multiple layers must be used, separating strips should be inserted between each layer – should such circumstances arise, please contact us.

If there is no alternative to routing several lines beside each other without sub-divisions, the clearance height within the carrier must be less than line diameter. This is the only way of preventing the cables from twisting.

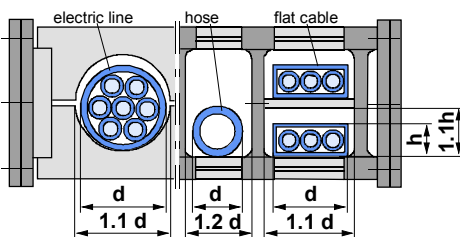

The supply cables must be able to move freely in the cable carrier. They must never be fastened or bundled together. **Separating strips must always** be inserted between flat cables routed in multiple layers.

### Recommended dimensions of the space required:

- with round cables (electrical cable): approx. 10% of the line diameter
- with hose lines: approx. 20% of the hose diameter
- with flat cables: for each, approx. 10% of the cable width and cable thickness

# Accessories HTR and HZR

## Attachment of position sensors and accessories

### Attachment variants for HZR position sensors

The limit switches are fitted ensuring that they are activated directly before the start of the standard safety travel (100mm). Unless otherwise agreed, the linear actuator is supplied with position sensors attached using attachment variant 1 (ZEB080 and ZEB100) resp. attachment variant 4 (ZEB050). The tripping plates, position sensors and distribution box are described on page 33.

#### Attachment variant 1 ZEB050/ZEB080/ZEB100

with three electrical (inductive) limit switches

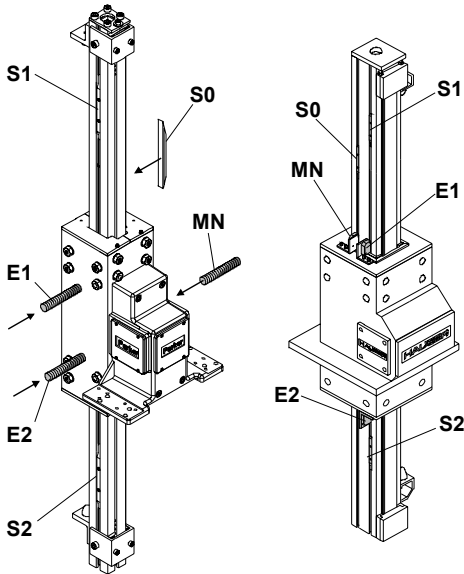

ZEB050

ZEB080 / ZEB100

#### Attachment variant 2 ZEB080/ZEB100

with one mechanical and one inductive limit switch

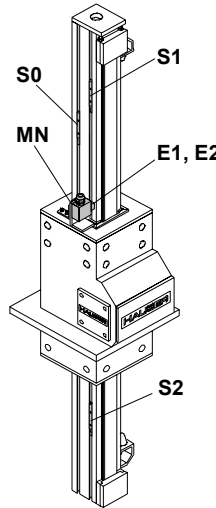

#### Attachment variant 3 ZEB050/ZEB080/ZEB100

with two mechanical and one electrical (inductive) limit switch

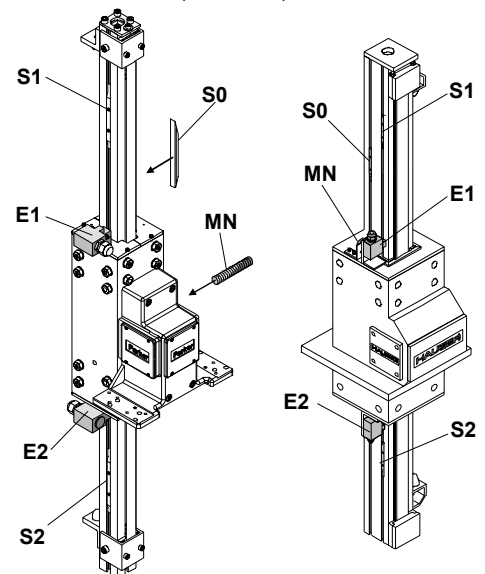

ZEB050

ZEB080 / ZEB100

#### Attachment variant 4 ZEB050

with one electrical (inductive) limit switch

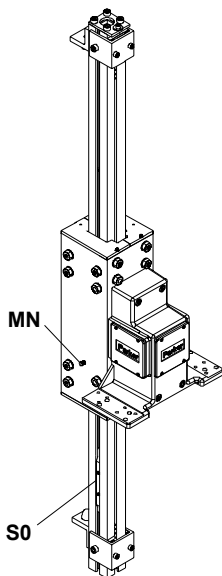

#### Key

- E1:** Limit switch 1
- E2:** Limit switch 2
- MN:** Home sensor
- S0:** Tripping plate for home sensor
- S1:** Tripping plate for limit switch 1 (E1)
- S2:** Tripping plate for limit switch 2 (E2)

#### Comments on ZEB050

The home sensor may optionally be mounted on the right or on the left side of the housing.

The electrical limit switches must always be mounted on the side of the housing opposite the home sensor.

The mechanical limit switches must always be mounted on the side of the housing opposite the home sensor or shifted by 90°.



# Accessories HTR and HZR

## Mechanical limit switch for HZR

The switching button complies with DIN EN 50047. The contacts satisfy the safety requirements in accordance with EN 60947-5-1 by virtue of forced opening (positively driven). The limit switch can be assembled on the angle plate in two ways (see picture on the left).

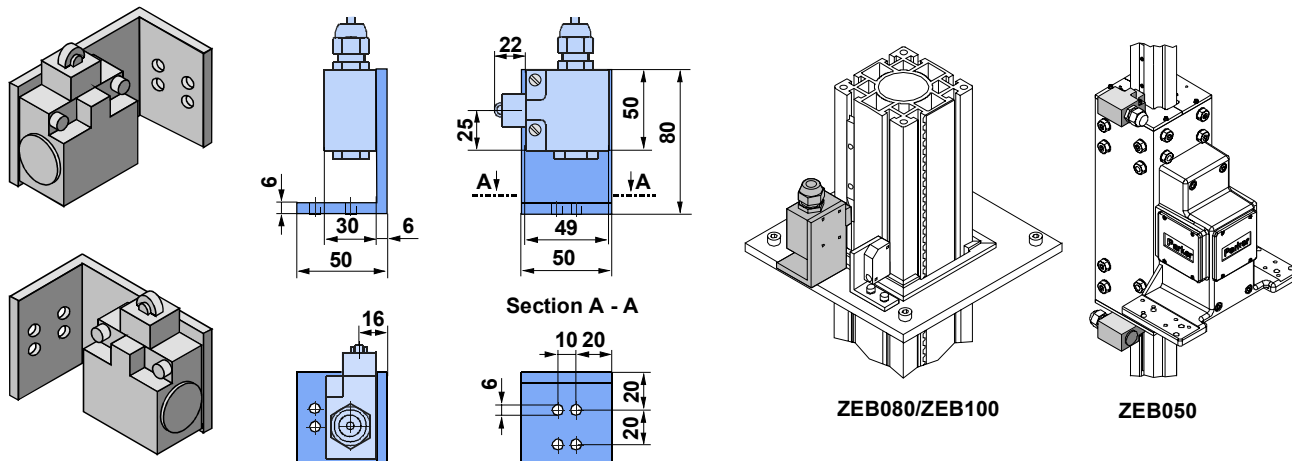

Description	Order no.
Mechanical limit switch for ZEB050 (including attachment material)	092-701031
Mechanical limit switch for ZEB080 and ZEB100 (including angle plate and attachment material)	510-900560

## Electrical limit switch (initiator) - only for ZEB080 and ZEB100

There are two different angle plates for attaching the switch (PNP-normally closed contact).

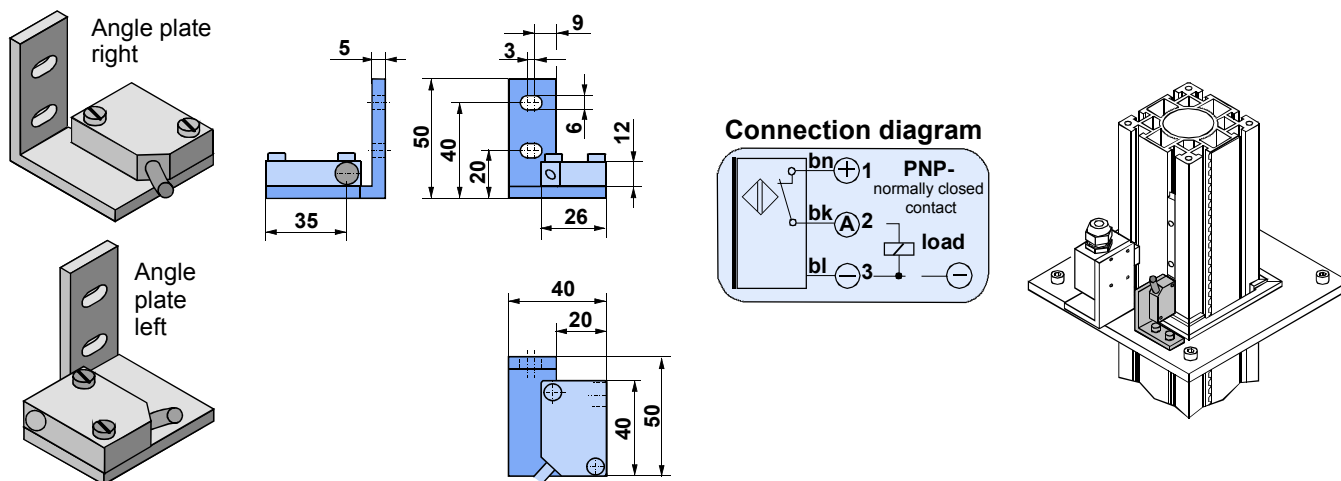

Description	Order no.
Electrical limit switch (PNP normally closed contact) - left (including angle plate and attachment material)	510-900604
Electrical limit switch (PNP normally closed contact) - right (including angle plate and attachments)	510-900605

Technical data		DC electrical data	
Operating distance	2mm / 4mm ± 10%	Rated voltage	24 V DC
Switch hysteresis	≥ 1% ... ≤ 15%	Voltage range	10...35 V DC
Repeatability	0.01mm	Supply current	≤ 15 mA
Temperature drift	< 10 %	Maximum load current	300mA
Ambient temperature	-25°C - +70°C	Residual voltage	≤ 2.5 V DC
Type of protection	IP67	Max. switching frequency	2kHz
Cable length	6m	Connection cable	3 x 0.25mm <sup>2</sup>

# Accessories HTR and HZR

## Cylindrical limit switch for ZEB50

The cylindrical limit switch may be optionally screwed in on the right or on the left side of the housing.

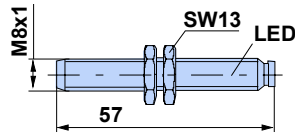
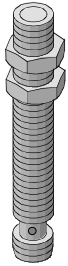

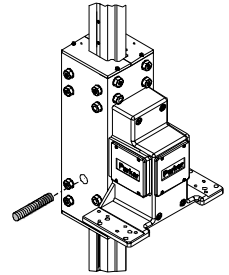
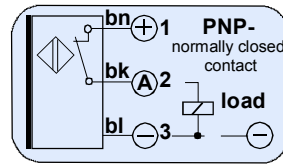

Connection diagram normally closed contact



Description	Order no.
Electrical limit switch for ZEB050 normally closed contact (incl. attachment material) (Cable: see picture below)	092-510636

Technical data		DC electrical data	
Operating distance	1.5mm / 2mm ± 10%	Rated voltage	24 V DC
Switch hysteresis	> 1% ... < 15%	Voltage range	10...35 V DC
Repeatability	0.01mm	Supply current	≤ 15 mA
Temperature drift	< 10 %	Maximum load current	300 mA
Ambient temperature	-25°C - +70°C	Residual voltage	≤ 2.5 V DC
Type of protection	IP 65	Max. switching frequency	5 kHz

Cable for the cylindrical limit switch. Coupling can be screwed directly to the initiator. Cable end for self assembly		
	Miniature angle coupling (90°), RKMVV 3-90, screw cap with self-securing knurled nut, with gated cable, length 10m, 3 x 0.34mm <sup>2</sup> (Please note: This cable is not suitable for the use in cable carrier chains)	080-900215
	Miniature coupling, RKMV 3-90, screw cap with self-securing knurled nut, with gated cable, length 10m, 3 x 0.34mm <sup>2</sup> (Please note: This cable is not suitable for the use in cable carrier chains)	080-900212

Cable for the cylindrical limit switch. Coupling can be screwed directly to the initiator. Cable ends may be directly connected to the COMPAX via a plug.					
Standard cable LiYCY 3 x 0.34 screened These cables are not suitable for the use in cable carrier chains)		Order no.	Highly flexible cable Unitronic-FD CP 3 x 0.14 screened. (Suitable for use in cable carrier chains)		Order no.
GBK 21/01	1m long	GBK21/01	GBK 22/01	1 m long	GBK22/01
GBK 21/02	2.5m long	GBK21/02	GBK 22/02	2.5 m long	GBK22/02
GBK 21/03	5m long	GBK21/03	GBK 22/03	5 m long	GBK22/03
GBK 21/04	7.5m long	GBK21/04	GBK 22/04	7.5 m long	GBK22/04
GBK 21/05	10m long	GBK21/05	GBK 22/05	10 m long	GBK22/05
GBK 21/06	12.5m long	GBK21/06	GBK 22/06	12.5 m long	GBK22/06
GBK 21/07	15m long	GBK21/07	GBK 22/07	15 m long	GBK22/07
GBK 21/08	20m long	GBK21/08	GBK 22/08	20 m long	GBK22/08
GBK 21/09	25m long	GBK21/09	GBK 22/09	25 m long	GBK22/09
GBK 21/10	30m long	GBK21/10	GBK 22/10	30 m long	GBK22/10
GBK 21/11	35m long	GBK21/11	GBK 22/11	35 m long	GBK22/11
GBK 21/12	40m long	GBK21/12	GBK 22/12	40 m long	GBK22/12
GBK 21/13	45m long	GBK21/13	GBK 22/13	45 m long	GBK22/13
GBK 21/14	50m long	GBK21/14	GBK 22/14	50 m long	GBK22/14

# Accessories HTR and HZR

## Tripping plate for HZR

The tripping plate is attached in the HZR profile and it activates the mechanical or electrical limit switch.

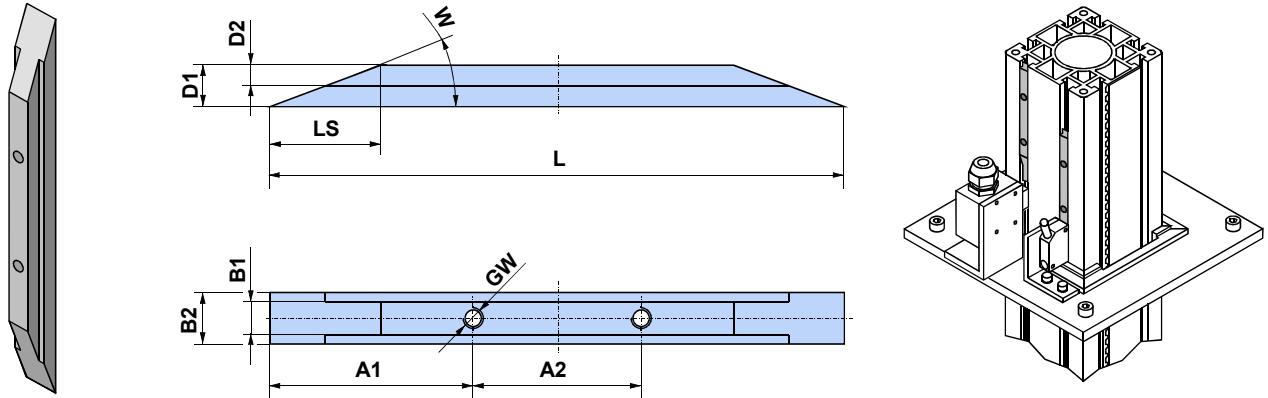

Actuator type	A1	A2	B1	B2	D1	D2	GW	L	LS	W	Order no.
ZEB050	30	50	10 -0.1	20	9	3.5 -0.1	M6	110	24.73	20	125-068605
ZEB080	52	50	8 -0.1	12	8	3.5 -0.1	M6	153	21.98	20	125-068325
ZEB100	60.5	50	9.6 -0.1	15	12	6 -0.1	M6	171	32.97	20	125-068608

### Attachment of the tripping plate

You need two threaded pins in order to attach a tripping plate

Actuator type	pieces	Description	Order no.
ZEB050	2	Threaded pin DIN913 M6x12	130-902029
ZEB080	2	Threaded pin DIN913 M6x8	130-902027
ZEB100	2	Threaded pin DIN913 M6x12	130-902029

## Limit switch gearbox for HTR

The limit switch gearbox contains a combination of electrical and mechanical limit switches (see table). It is available with a reduction ratio of  $i=8$  and is assembled opposite the drive/gearbox combination.

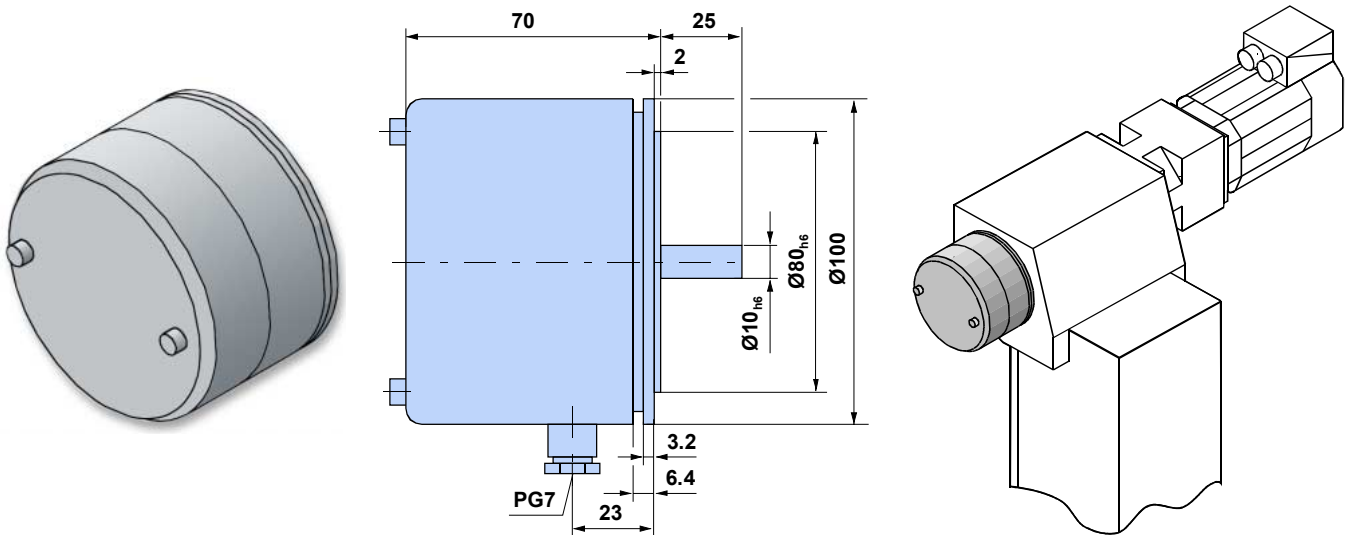

Description	Initiator PNP normally opened contact	Initiator PNP normally closed contact	mechanical limit switch	Order no.
Limit switch gearbox 1:8 with:	--	3	--	029-180001
Limit switch gearbox 1:8 with:	2	1	--	029-180002
Limit switch gearbox 1:8 with:	--	1	2	029-180003
Limit switch gearbox 1:8 with:	1	--	2	029-180004

# Accessories HTR and HZR

## Distribution box

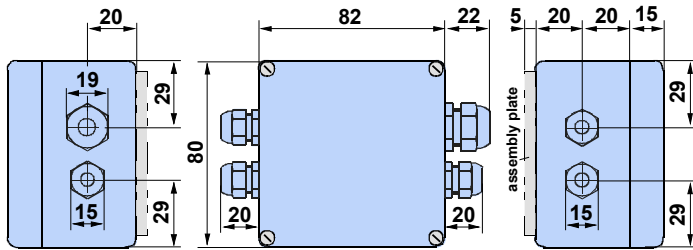

Only for limit switch attachment variant 1!

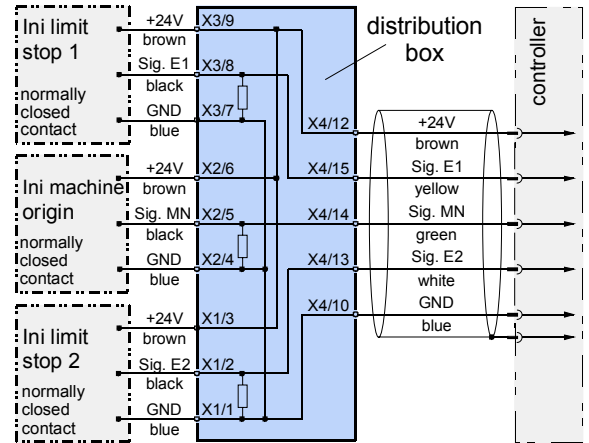

Description	Order no.
Attachment components for distribution box on ZEB050	510-900710
Attachment components for distribution box on ZEB080/ZEB100	510-900610

Description	Order no.
Distribution box incl. 2.5m cable	800-003102
Distribution box incl. 5m cable	800-003103
Distribution box incl. 7.5m cable	800-003104
Distribution box incl. 10m cable	800-003105
Distribution box incl. 12.5m cable	800-003106
Distribution box incl. 15m cable	800-003107
Distribution box incl. 20m cable	800-003108

Description	Order no.
Distribution box incl. 25m cable	800-003109
Distribution box incl. 30m cable	800-003110
Distribution box incl. 35m cable	800-003111
Distribution box incl. 40m cable	800-003112
Distribution box incl. 45m cable	800-003113
Distribution box incl. 50m cable	800-003114

## Assembly angle plate for HTR

The assembly angle plate is used to connect an HTR unit

- to another linear actuator
- to other machine components

This is available in two sizes with through-holes.

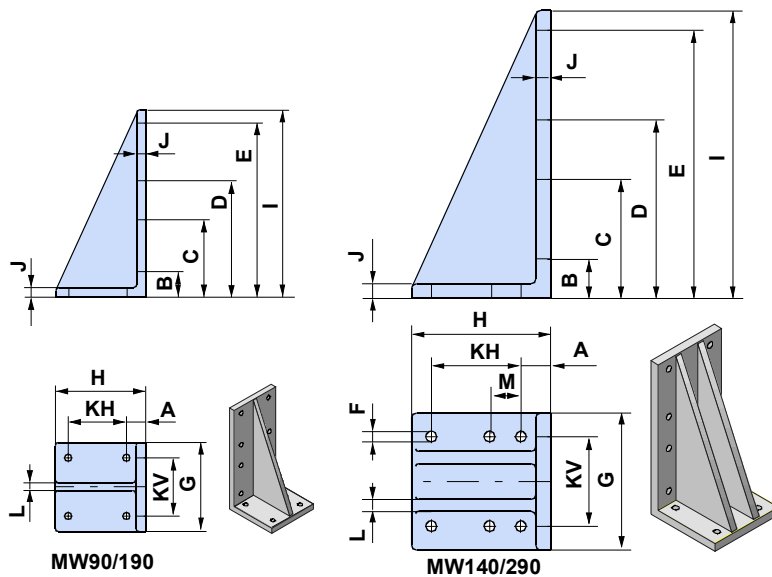

Actuator type	Type	A	B	C	D	E	F	G	H	I	J	KH	KV	L	M	Order no.
T3B050	MW 90/190	37.5	20	80	120	180	Ø6.6	88	90	190	10	60	60	10	--	500-000516
T3B080	MW 140/290	55	40	120	180	270	Ø11	138	140	290	15	65	90	12	25	500-000524

# Accessories HTR and HZR

## Connection set for HZR50

The connection set is used to connect a HZR50 unit to another actuator (HPLA80 or HPLA120) and consists of an assembly angle plate (1) and the respective screws (4), t-nuts (5), connection plate (2) and division plate (3 – only for connection to a LB..080 actuator).

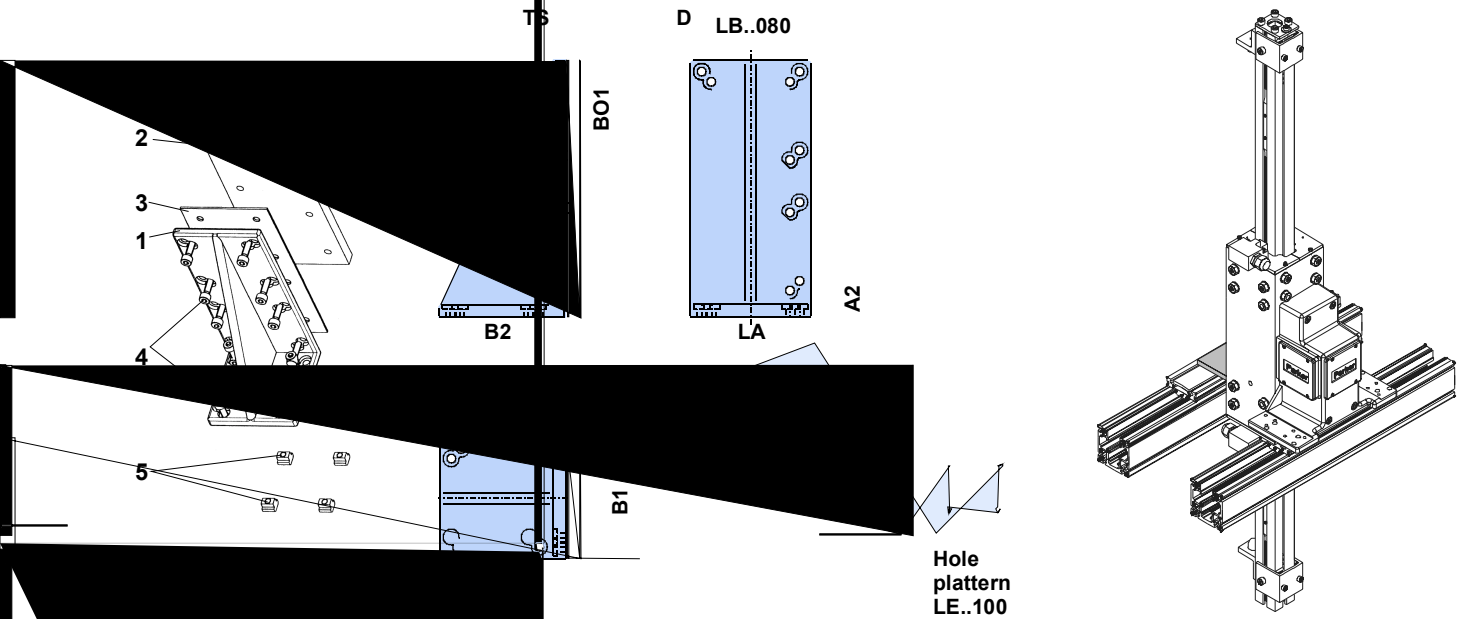

Actuator type	A1	A2	A3	A4	A5	BO1	BO2	B1	B2	B3	D	LA	LA1	T	BP	Order no.
LB..080					150	Ø5.5	Ø10	74	77	157	8	54	6	3	11.5	510-000630
LE..100					180	Ø9	Ø9	80	90	190	10	60	--	--	20	510-000631

## T-nuts and bolts for HZR

The... (DIN787) can be used to attach other components in the T-slots of the profile, or to the upper...

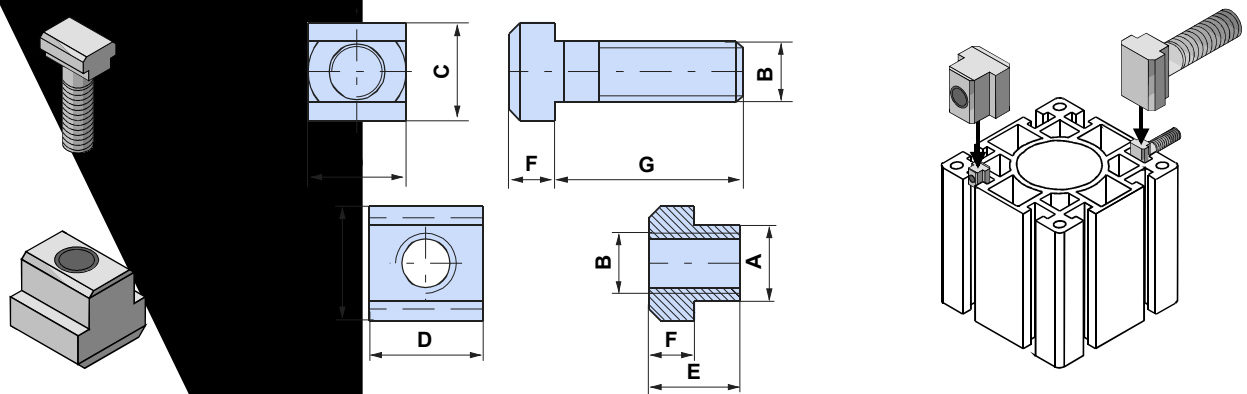

Actuator type	Description	A	B	C	D	E	F	G	Order no.
ZEB080	Bolt DIN787 M8x8x25	--	M8	--	13	--	6	25	131-700001
ZEB100	Bolt DIN787 M10x10x25	--	M10	--	15	--	6	25	131-700007
ZEB080	Bolt DIN787 M8x8x32	--	M8	--	13	--	6	32	131-700002
ZEB100	Bolt DIN787 M10x10x32	--	M10	--	15	--	6	32	131-700008
ZEB080	Bolt DIN787 M8x8x40	--	M8	--	13	--	6	40	131-700003
ZEB100	Bolt DIN787 M10x10x40	--	M10	--	15	--	6	40	131-700009
ZEB050	Nut "Page" M8x10	10	M8	16	20	6	4.5	--	131-700090
ZEB080	Nut DIN508 M6x8	8	M6	13	13	10	6	--	131-700103
ZEB100	Nut DIN508 M8x10	10	M8	15	13	12	6	--	131-700104
ZEB080	Long nut* HWN313 ZN M6x8	8	M6	13	26	10	6	--	131-700140
ZEB100	Long nut* HWN313 ZN M8x10	10	M8	15	30	12	6	--	131-700141
ZEB080	Nut ITEM St M6	without drawing							400-000033
ZEB100	Nut ITEM St M8	without drawing							400-000034

\* When using the combination of two linear actuators via clamping profiles, we would recommend the use of long nuts.

### Other accessories / software



#### **Belt tension measuring device RSM:**

For accurately setting the timing belt tension  
(Order no.: 037-000201).



#### **DimAxes:**

Dimensioning software for the rollers of linear actuators HLE, HPLA, HZR, HTR, BLMA for PC, Windows 95 or higher.

Free download:

<http://www.parker-eme.com>



Download of the DimAxes software, DXF files of HLE and HPLA linear actuators free of charge:  
[www.parker-eme.com](http://www.parker-eme.com)





# - Your partner for automation

Would you like more information?  
We would be happy to send you our brochures and catalogs!  
Or call us and set up a meeting.

## Our product program:

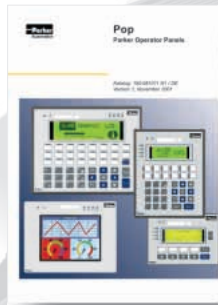

Visualisation



Distributed Automation



Control Technology



Drive Technology  
Servo Drives / Stepper Drives



Motors / Gears



Direct Drive Technology  
Linear motors / Torque motors



Handling Actuators  
Cylinders / Actuators



Precision Actuators  
Screw Driven / Linear Motor Driven



Parker  
Electromechanical Automation



**Parker Hannifin GmbH & Co.KG**  
Electromechanical Automation  
Robert-Bosch-Str. 22  
D-77656 Offenburg,  
Germany  
☎ +49 (0)781 509 0  
☎ +49 (0)781 509 98176  
Website: [www.parker-eme.com](http://www.parker-eme.com)  
e-mail: [sales.hauser@parker.com](mailto:sales.hauser@parker.com)

**Parker Hannifin S. p. A**  
Electromechanical Automation  
Via Gounod 1  
I-20092 Cinisello Balsamo (MI),  
Italy  
☎ +39 0266012459  
☎ +39 0266012808  
Website: [www.parker-eme.com](http://www.parker-eme.com)  
e-mail: [sales.sbc@parker.com](mailto:sales.sbc@parker.com)

**Parker Hannifin plc**  
Electromechanical Automation  
Arena Business Centre  
Holy Rood Close, Poole, Dorset.  
BH17 7BA UK  
☎ +44 (0)1202 606300  
☎ +44 (0)1202 606301  
Website: [www.parker-eme.com](http://www.parker-eme.com)  
e-mail: [sales.digiplan@parker.com](mailto:sales.digiplan@parker.com)

We reserve the right to make technical changes.  
The information contained in this manual corresponds to the current status at the time of printing.