

# PA PowerStation Family



## The Power of Interact HMI In An Affordable Package

This family of PowerStations is CTC-designed and manufactured to be an economical push button panel replacement solution with the option to include advanced software features. Including 5", 6", 8", 10.4" and 15" color touchscreen displays, all units combine the connectivity, functionality and expandability of Interact HMI software with standard hardware features such as CompactFlash storage, RS-232, RS-422/485 and 100BaseT Ethernet ports. These updated PA models also include an enhanced motherboard and CompactFlash card ejector. PA PowerStations allow you to choose the right system for your application without sacrificing the features you need.

## New 15" Display!

### The PA PowerStation family is...

- CTC-designed and manufactured for reliability with consistent hardware features for all units
- Feature-rich with Interact Panel Tools, Graphics, Alarming and Networking software features
- Expandable with optional Interact software modules such as Historical Trending and advanced recipe management
- Flexible connectivity including 50+ communication drivers - including Ethernet drivers
- Designed for easy "drop-in" replacement of popular operator panels

### Includes...

- 5", 6", 8", 10.4" and 15" Touchscreen Displays
- CompactFlash and 100-Base-T Ethernet
- Interact HMI Software with advanced module support
- Multiple control device connectivity
- Slim profile with consistent features
- Quick and easy clip mounting
- Type 4/4X rating

All published product specifications are subject to change without notice.





## Model Number Configurations

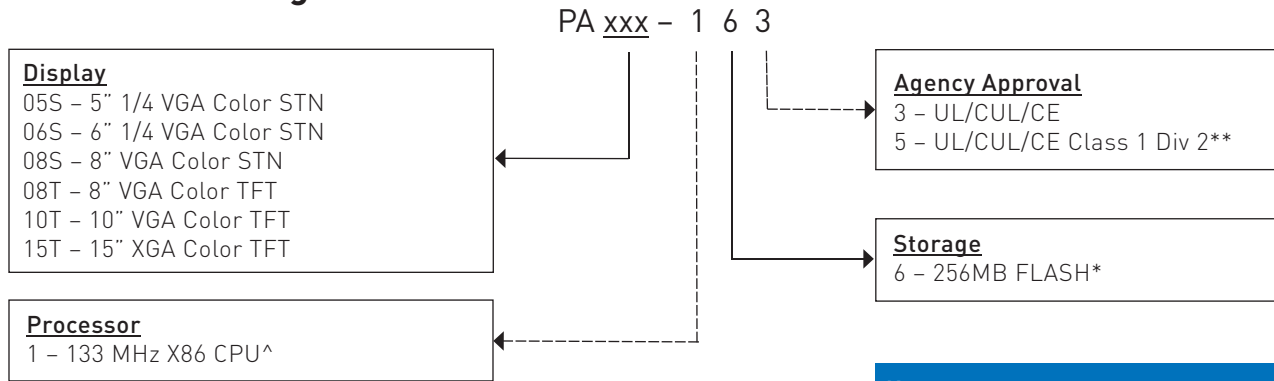

\* Actual storage volumes may be higher

\*\* Class 1 Div 2 is pending on PA15T display and is an extra-cost option on other display models

^ PA15T models include a LX700 [433 MHz] processor

**Note:**  
 All systems include 0-50 °C operation, analog resistive touchscreen, NEMA 4/4X rated package and agency approvals for CE, UL & CUL.

## Specifications

Categories	Features	PA05S/PA06S	PA08S	PA08T	PA10T	PA15T
Display	Specification	5/6" Color STN 1/4 VGA (320 x 240) 4.7/5.7" Diagonal 5":160 NIT, 6": 350 NIT +/- 50° L/R 5": 20°U, 30°D 6": 20°U, 35°D	8" Color STN VGA (640 x 480) 7.7" Diagonal 120 NIT +/- 50° L/R 30°U, 50°D	8" Color TFT VGA (640 X 480) 8.0" Diagonal 285 NIT +/- 65° L/R 65°U, 55°D	10" Color TFT VGA (640 x 480) 10.4" Diagonal 200 NIT +/- 70° L/R 40°U, 70°D	15" Color TFT XGA (1024x768) 15.1" Diagonal 260 NIT +/-80° L/R 55°U, 65°D
	Weight: Size: (HxWxD)	2.1 lbs. 6.0" x 7.4" x 2.26"	4.1 lbs. 7.6" x 10.2" x 2.53"	4.1 lbs. 7.6" x 10.2" x 2.53"	8.4 lbs 11.0" x 13.78" x 2.93"	14.2 lbs 13.30" x 16.80" x 5.19"
	Cut Out: (WxH)	6.20" x 4.91" PV 550T/600T Compatible	8.67" x 6.08" PV+ 700T Compatible	8.67" x 6.08" PV+ 700T Compatible	12.60" x 9.86"	15.90" x 12.40"
	Interface	Analog Resistive Touchscreen				
HMI Software		Interact Runtime included (PTM, GMM, AMM and NET)				
Processor		133MHz X86 CPU				AMD LX700 [433 MHz]
Storage	CompactFlash	256MB CompactFlash External				
Ports	Keyboard Mouse USB Serial Ethernet	 (1) PS/2, with over current protection (1) PS/2, with over current protection None (1) RS-232, (1) RS-232/422/485 (1) 10/100Base-T w/ RJ45				USB 2.0 USB 2.0 (2) USB 2.0, Type A (1) RS-232, (1) RS-232/422/485 (1) 10/100Base-T w/ RJ45
Package	Temperature Range Rel. Humidity Vibration Shock	0-50°C 5-95% (non-cond.) 10-500 Hz 2grms (Random) 10G, 11 msec (operating) 30G, 11 msec (non-operating)				
Power Requirement		12/24VDC, 18 Watts				
Agency Approval		CE; UL/CUL, NEMA 4/4X; Class 1 Div. 2				

For more information about PA PowerStation Family  
 visit [www.ctcusa.com](http://www.ctcusa.com) or call us at **1-800-233-3329**

All published product specifications are subject to change without notice.



PA05S/PA06S Cutout Dimensions:

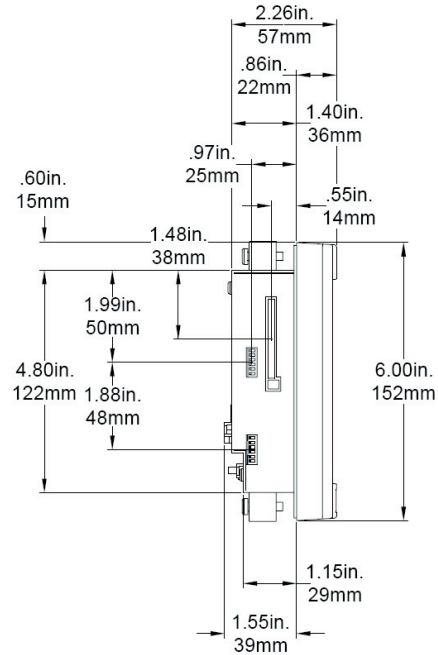
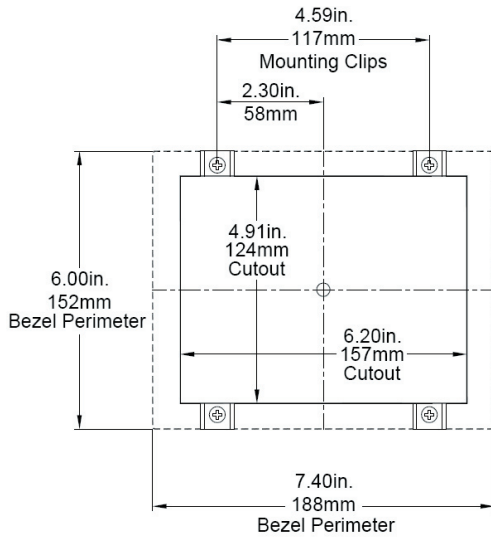

PA08S/PA8T Cutout Dimensions:

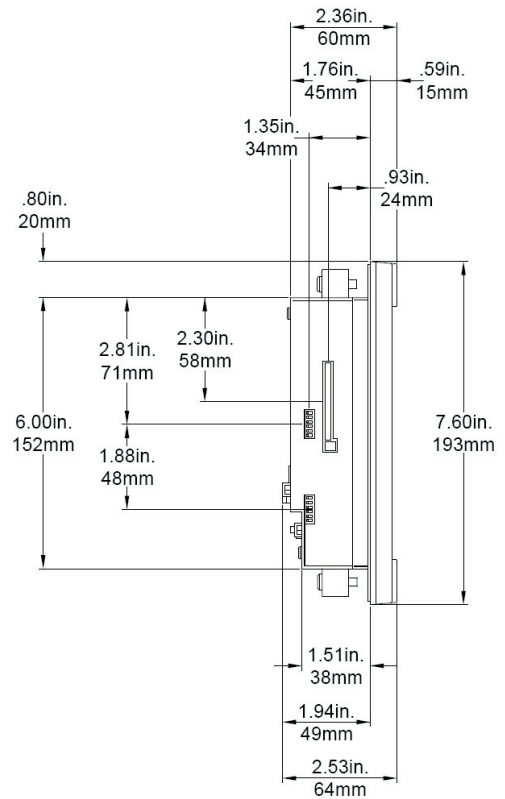
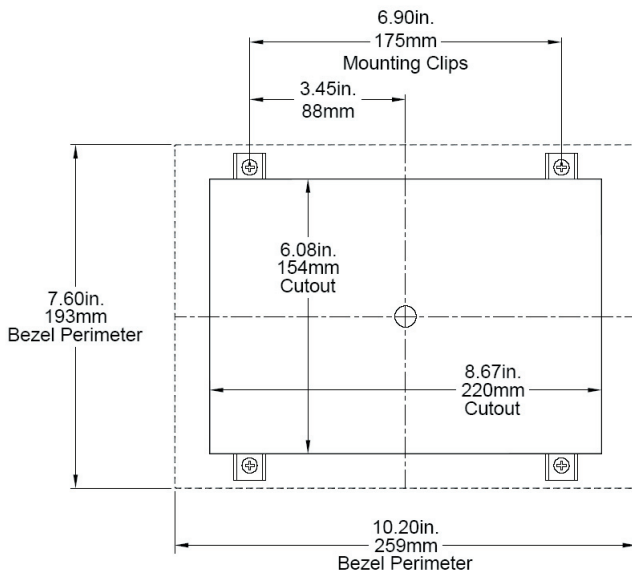

All published product specifications are subject to change without notice.



**PA10T Cutout Dimensions:**

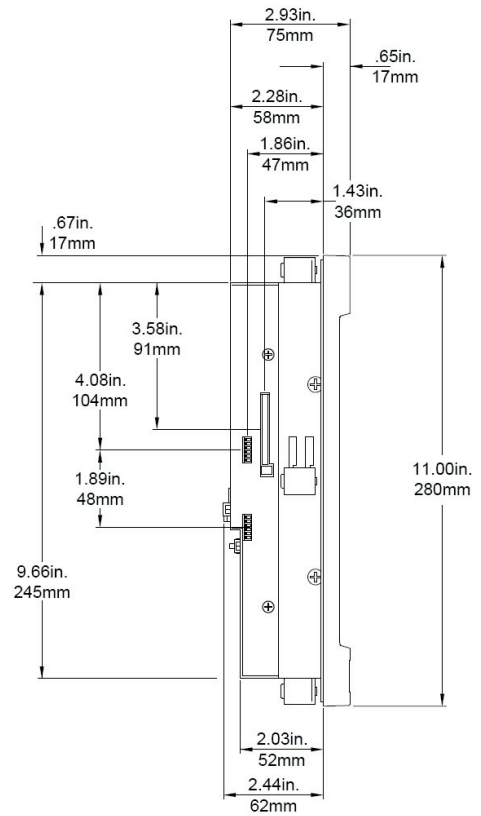
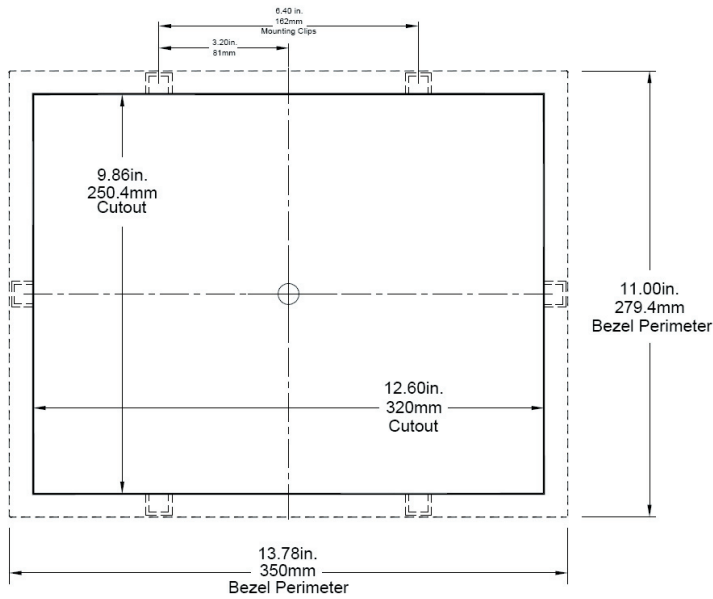

**PA15T Cutout Dimensions:**

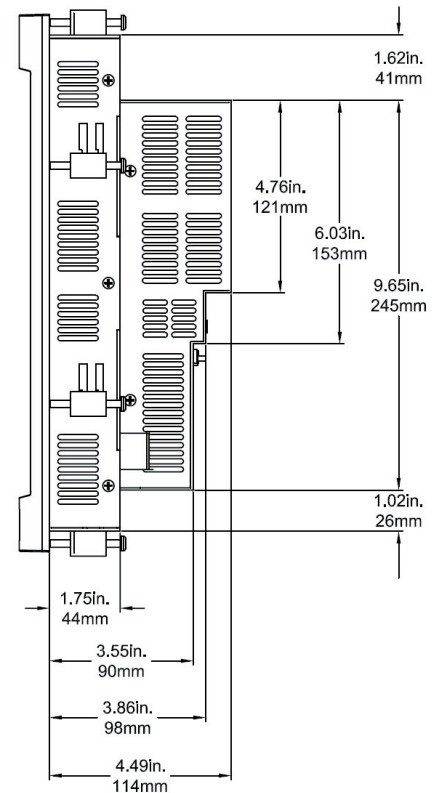
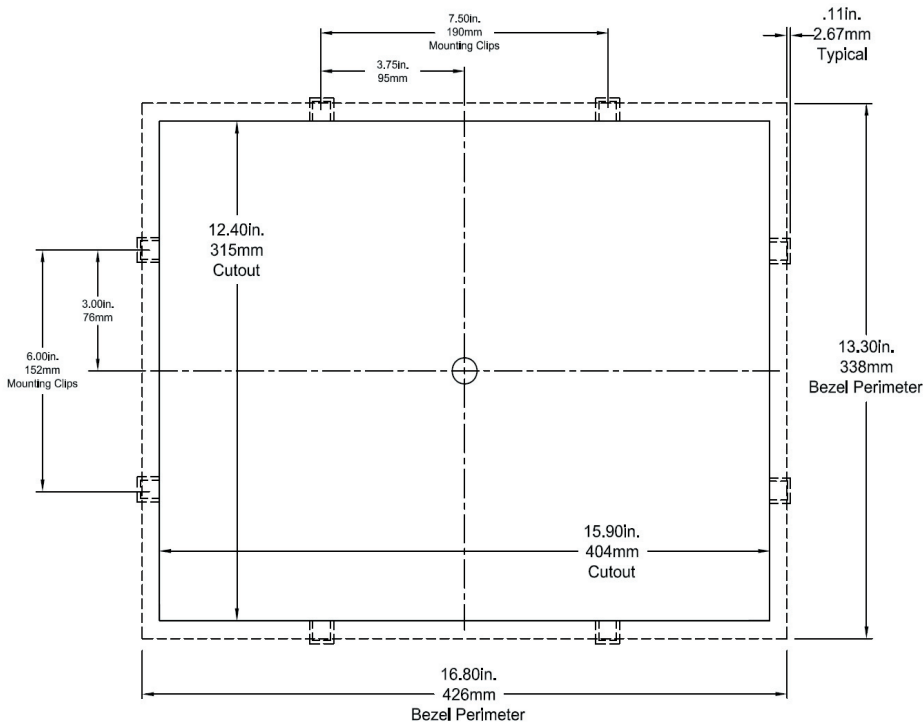

All published product specifications are subject to change without notice.