

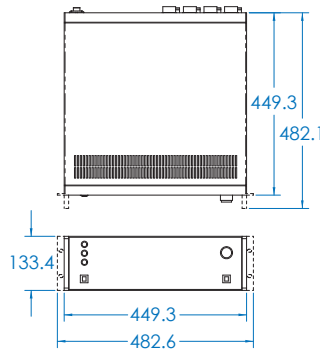

### Feature Summary:

- 1 to 4 axes of motor drive
- Integrated Galil motion controller
- Ethernet or RS-232 interface
- Drive options for servo and stepper motors
- 48 & 75 VDC motor supply option
- Integrated motor power control system
- Compatible with all Primatics positioning stages as well as 3rd party motors and stages
- Easy to program with support for DOS, Linux and all versions or Windows
- 110 or 220 VAC, 50/60 Hz input



Note: dashed lines indicate dimensions for rack mount handles.

### Overview

The Primatics MDC1400 is a highly integrated multi-axis motion control system in a 3U tall chassis. A Galil high performance motion controller is embedded, offering advanced features such as PID compensation with velocity and acceleration feed-forward, program memory with multitasking for simultaneously running up to four programs, and uncommitted I/O for synchronizing motion with external events. Modes of motion including point-to-point positioning, jogging, linear and circular interpolation, contouring, electric gearing and ECAM. The MDC1400 uses a simple, English-like command language

which makes it very easy to program. Communication drivers are available for DOS, Linux and all current Windows operating systems. RS232 & Ethernet 10-base-T are standard communication interfaces.

### Drives

All power supplies, wiring and safety circuits are contained in the chassis, and the appropriate motor drive is installed for your application. Drives features a separate control card and can be connected to motion axes with a variety of accessories. Drives are available for servo (brushed and brushless) and step motors.



MDC1400 Back View

For more information and a complete datasheet, go to [www.primatics.com](http://www.primatics.com)

Performance Specifications	MDC1400
Number of Motion Axis	1 to 4
Motor Compatibility	Brush and brushless rotary and linear, stepper
Motion Controller	Galil 21x3 Series
Motor Voltage (VDC)	48 or 75VDC
Continuous Output Power (watts)	700
Peak Output Power (watts)	1400
Dimensions (H x W x D) (mm)	133.4 x 449.3 x 449.3
Operating Temperature (deg C)	0 to 45
Storage Temperature (deg C)	0 to 75
Weight (kg)	15



Linear Positioning

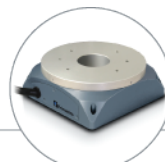

Rotary Positioning



Motion Controls

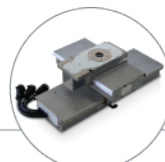

OEM Solutions

# MODEL NUMBER CONFIGURATION

OPTIONS :

SAMPLE MODEL NUMBER :

MDC1400 R 4 -48V W4 -D1 -D3 -D3 -D4 -XXXX

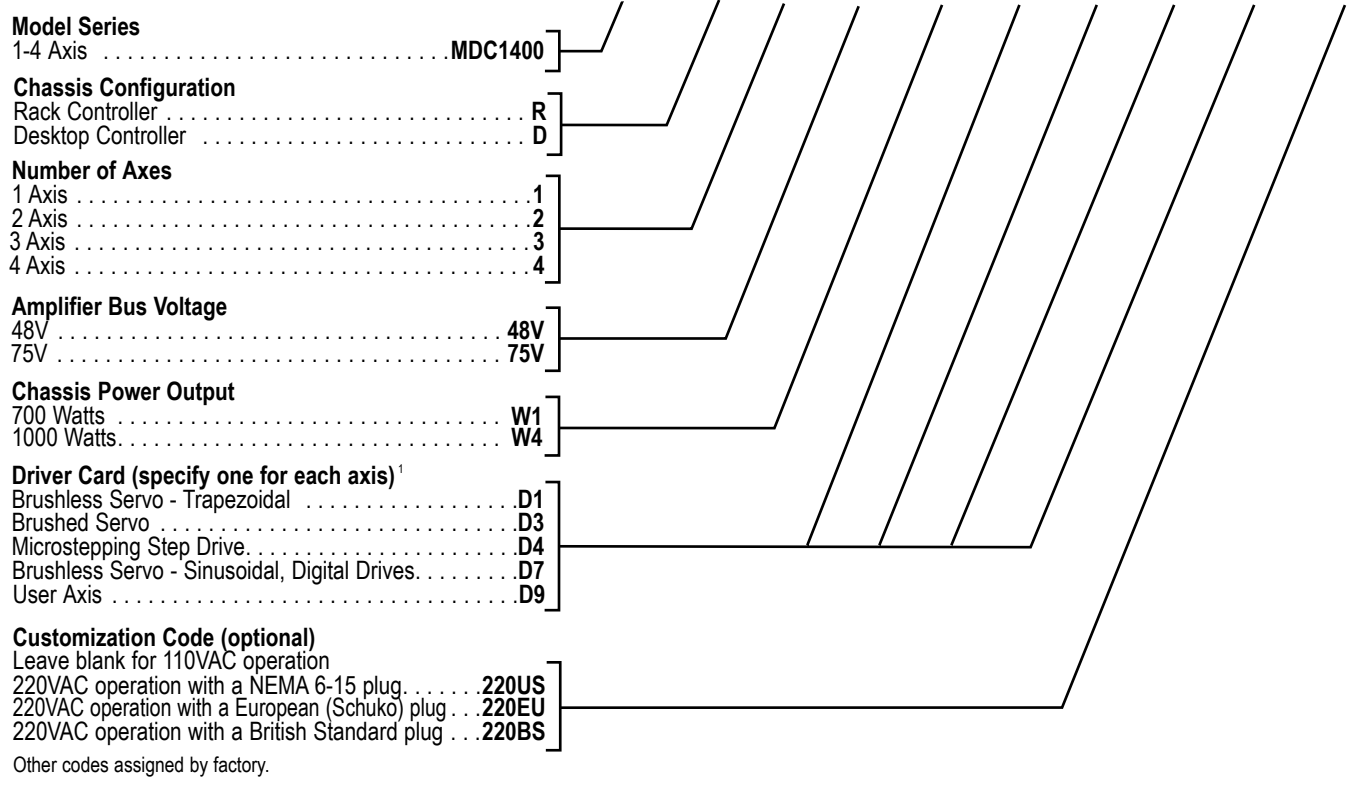

<sup>1</sup> The Drive Options are based on the following:  
D1 - Trap drive, 6A continuous, 12A peak, 20-85V  
D3 - Trap drive configured for brush operations, 6A continuous, 12A peak, 20-85V  
D4 - Step drive, 5A RMS/7A peak, 24-75V  
D7 - Digital sinusoidal drive, 3A continuous, 9A peak, 20-85V  
D9 - User axis

