

**We Make The Motion That
Makes The World Move**

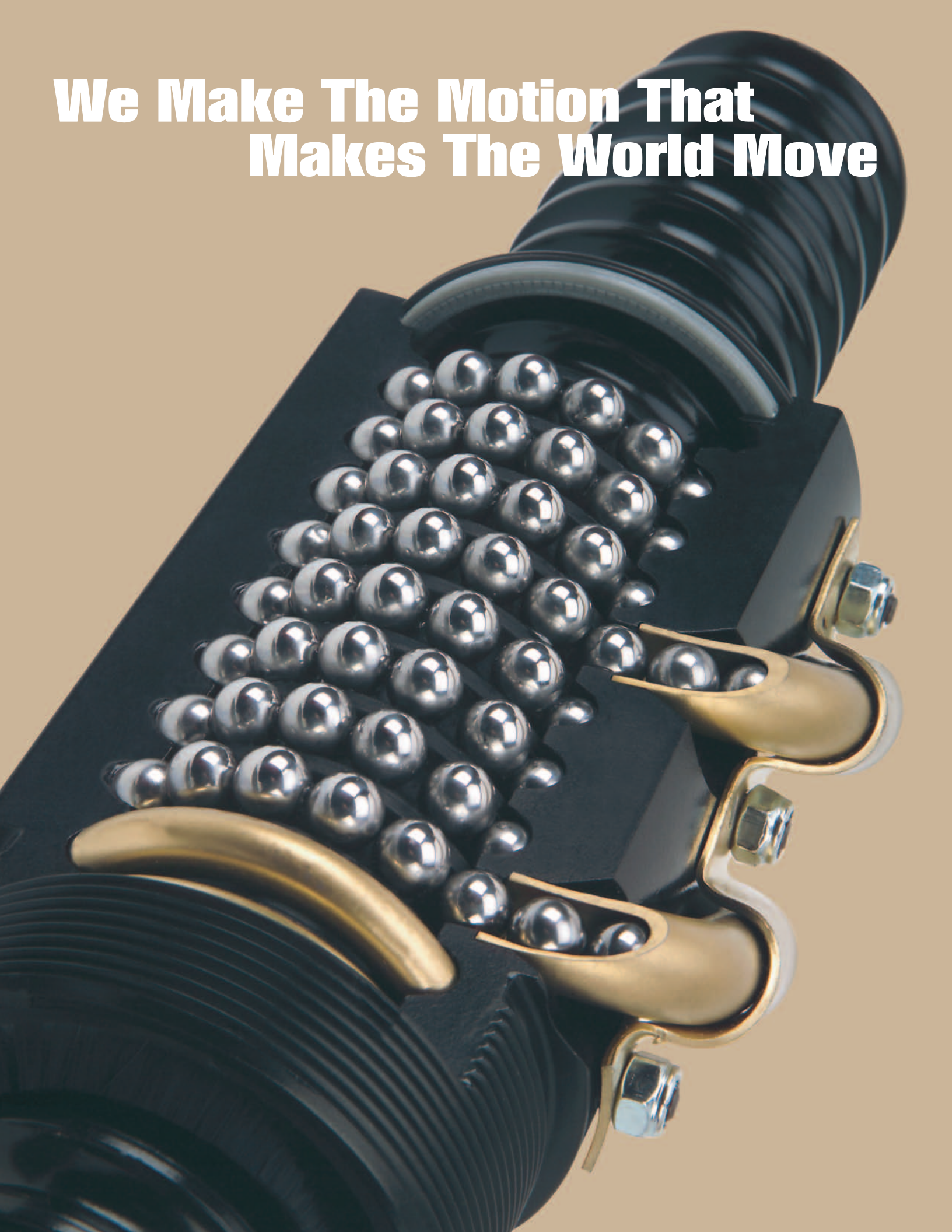

[Our Customers Come First]



Ian McBain founded the Rockford Ball Screw Company in 1973 with three goals in mind:

- 1) Provide the customer with a quality product
- 2) Provide the customer with a competitive price
- 3) Provide the product on time

Today, the Rockford Ball Screw Company continues as a family owned and operated business, and Ian's three goals endure as the backbone of our growth and commitment to our customers needs.

Rockford Ball Screw products are built to the highest performance design

standards. Extensive engineering expertise and a state-of-the-art manufacturing facility ensure top performance and reliability in our products. Our ball screw and ACME screw product lines feature 81 standard models and the largest inventories in the industry. Rockford Ball Screw is an ISO 9001:2000 registered company committed to continuous improvement and dedication to total customer satisfaction. Call us today and see for yourself what "service" really means!



We are pleased to announce our new web site. The new user friendly site is more informative to help you choose the proper ball or ACME screw for your application. It contains downloads of 2D and 3D drawings, technical data, service/repair manuals, cross reference charts, quotation requests, contact information, and other helpful items. Log on to www.rockfordballscrew.com to learn more about our company, our services and our products.



www.rockfordballscrew.com

- Quick and easy navigation.
- Up to date information on new products.
- Over 125 data pages in Adobe® Acrobat® format.
- Specific information on Rockford Ball Screws, ACME screws and other componentry.
- Information on sizing including critical speed and column load graphs.
- Direct access to service and repair manuals.
- Cross reference chart for interchangeability with other manufacturers.

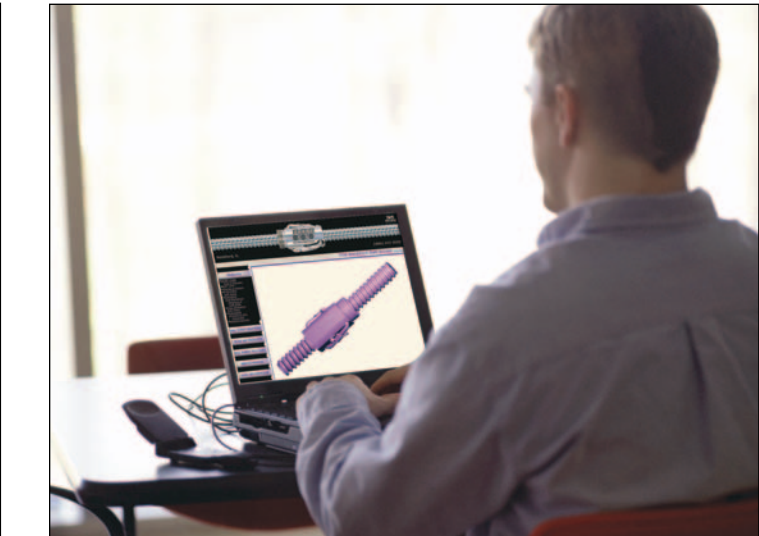

3D Configurable Downloads

You can now go to www.rockfordballscrew.com and download 2D/3D drawings of our products and customize them to your specifications. We offer downloadable drawings for all major CAD programs.

For more information, call our friendly customer service department at **1-800-475-9532** to request a free CD that contains all of our technical drawings in 2D/3D and other information regarding our vast capabilities.

ABOUT BALLSCREWS

A ball bearing screw is just that: a screw which runs on ball bearings. The screw and nut have matching helical grooves or races, and the ball bearings recirculate in these races. There is no physical contact between the screw and the nut. As the screw or nut rotates, and the rolling balls reach the trailing end of the nut, they are deflected or guided from this “pitch” contact by means of a return tube and returned to the leading end of the circuit. There, the cycle resumes and the balls recirculate continuously.



| | |
|----------------------------|---|
| Major Diameter | (Land Diameter) The outside diameter of the screw thread. |
| Minor Diameter | (Root Diameter) The diameter of the screw shaft as measured at the bottom of the ball thread track. This diameter is used in column load and critical speed calculations. Minor diameter also is a consideration in support bearing selection. |
| Ball Pitch Diameter | (Ball Circle Diameter) The theoretical cylinder passing through the center of the balls when they are in contact with the ball screw and ball nut races. |
| Lead | The axial distance the screw or nut travels in one revolution. |
| Lead Error | (Accuracy) The difference between the actual distance traveled compared to the theoretical travel based on the lead of the screw. The lead error for a standard screw will not exceed $\pm .007$ " per foot and a premium grade screw will not exceed $\pm .003$ " per foot. Lead error is cumulative based on the actual length of the ballscrew thread. Ref. Class 7-8 ANSI B5.48-1977. Lead charts describing incremental lead deviation offsets can be supplied (upon request). These incremental offsets can be input into motion controllers for lead error compensation. |
| Matched Leads | (Synchronous Screws) Used when multiple screws are being driven by a single drive in order to keep the screws in sync. Basically the lead errors are matched at the factory in order to minimize misalignments during the stroke. Consult factory for additional information on matched leads. |
| Pitch | The distance from one thread on the screw to a corresponding point on the next thread parallel to the screw axis. Pitch is equal to the lead on single start screws. |
| Screw Starts | The number of independent threads on the screw shaft. The lead of the screw is calculated by dividing the threads per inch by the number of starts. |
| Backlash | The axial free motion between the nut and the screw. It determines the amount of lost motion between the nut and screw on a horizontal application. Backlash on standard nuts range from .005 to .015, depending on the size of the screw. |
| Selective Fit | The process of selecting a unique ball size for reducing backlash to as little as .001 inches. |

Preloading

Method of eliminating backlash in a ball screw assembly. This is accomplished by the use of one group of ball grooves in opposition to another to eliminate backlash. Preloading increases stiffness (resistance to deflection) and provides for accurate positioning with very little increase in applied torque or load capability.

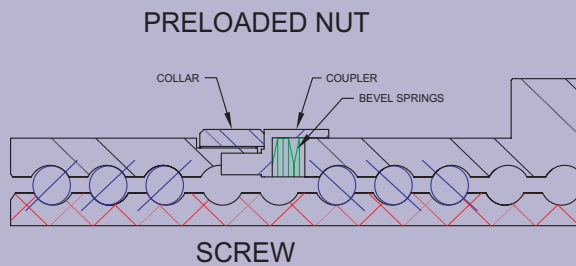

Rockford Ball Screw preloaded ballscrew assemblies consist of two standard ballnuts joined by an adjustable preload package containing a collar, coupler and bevel or wave springs. The preload package has been designed to exert an axial separating force between the adjacent ballnuts thereby generating the requisite preload. Preloaded ball screw assemblies are required when positioning accuracy and repeatability must be maintained.

The adjustable preload can be set in a range between 10% (recommended) and 30% (maximum) of the dynamic load rating. While staying within this range, the assemblies demonstrate little loss of load carrying capacity or life.

The three preload examples to the right illustrate the effects of load size and direction on preloaded units. The examples are important in selecting the size of preload and amount of preload force needed. The direction of loading effects ball screw stiffness and potential backlash.

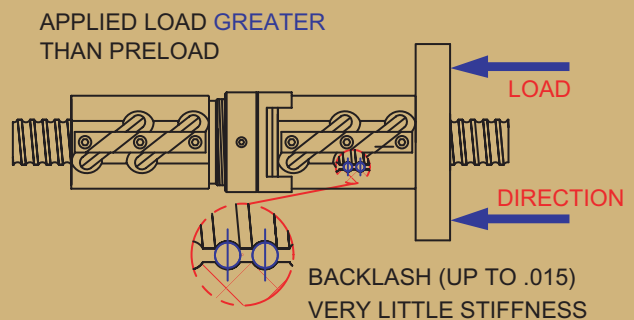
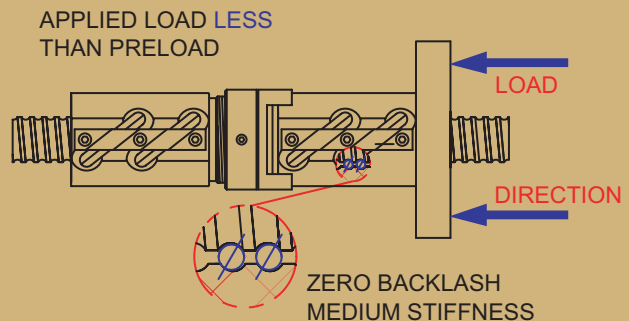
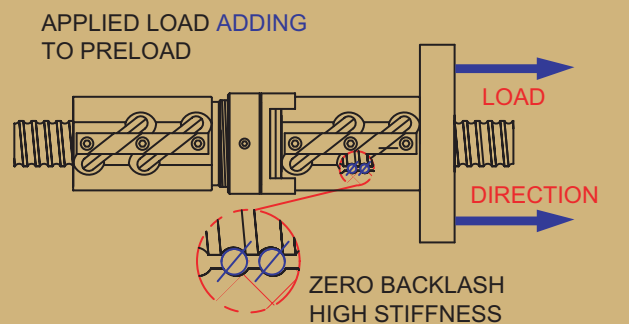

Efficiency

Expressed as a percentage and is the ability of a ball screw assembly to convert torque to thrust with minimal mechanical loss. Rockford Ball Screws operate in excess of 90% efficiency.

ABOUT BALLSCREWS

| | |
|-------------------------|---|
| Dynamic Load | The maximum thrust load under which a ball screw assembly will achieve a minimum of 1,000,000 inches of travel before first signs of fatigue are present. |
| Static Load | The maximum non-operating load capacity above which permanent damage of the ball track occurs. |
| Tension Load | A load that tends to stretch the ball screw. This is the preferred mode of attaching the load since column loading limitations would not effect the screw. |
| Compression Load | A load which would tend to compress or buckle the screw shaft. Use column load calculations to determine safe compression loads. |
| Axial Loading | The recommended method of attaching the load to the ballnut. This load should be parallel to the centerline of the screw shaft and equally distributed around the mounting surface. |
| Eccentric | (Moment Loading) A load tending to cock the ballnut on the screw and therefore reducing the rated life. |
| Side Loading | (Radial Loading) A load that is applied perpendicular to the screw shaft. This type of loading will also reduce the rated life of the ball screw assembly. |

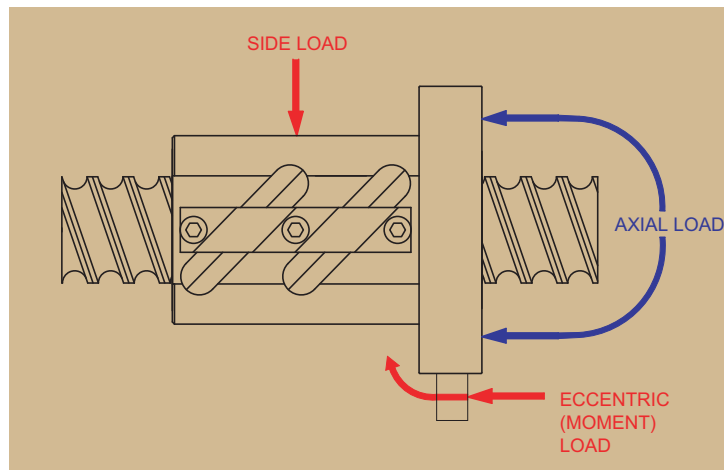

Ball Screw Life (Life Expectancy) Expressed as total accumulated inches of travel under a constant rated thrust load (with proper lubrication and clean environment) before first evidence of fatigue develops (1,000,000 inches under stated rated loads). Ball screw life is rated similar to ball bearings (L10 or B10). The B10 life rating states that 90% of a similar group of screws will achieve this life. Although 10% will not achieve the life, 50% could exceed life by 5 times.

Applied Dynamic Loading Each unique application needs to be evaluated such that ALL force components are realized and accounted for. The force components might include: weight of the sliding mechanism (if vertical), weight of the sliding mechanism multiplied by the coefficient of sliding friction (if horizontal), any direct forces resisting the linear motion (such as tool cutting loads), and any other applicable force components.

$$P = Wf * \mu + Fp$$

| | | | |
|----|---|---|-------|
| P | = Applied Dynamic Load (LBS) | Coefficient of sliding friction for non-vertical loading applications | |
| Wf | = Weight of Sliding Load (LBS) | Steel on Steel | ~.58 |
| μ | = Coefficient of sliding friction (=1 if load orientation is vertical) | Steel on Steel (greased) | ~.15 |
| Fp | = Force component pushing directly against the sliding mechanism | Aluminum on Steel | ~.45 |
| | | Gibb Ways | ~.50 |
| | | Dove Tail Slides | ~.20 |
| | | Linear Bearing (Ball Bushings) | <.001 |

Equivalent Load

This calculation is used in applications where the load is not constant throughout the entire stroke. This equivalent load can be used in life calculations. In cases where there is only minor variation in loading, use greatest load for conservative life calculation. Please note that the drive torques and horsepower requirements should always be based on the greatest thrust load encountered.

$$P_e = \sqrt[3]{\frac{\%_1(P_1)^3 + \%_2(P_2)^3 + \%_3(P_3)^3 + \%_n(P_n)^3}{100}}$$

P_e = Equivalent Load (lbs)
 P_n = Each Increment at Different Load (lbs)
 $\%_n$ = Percentage of stroke at load increment

Example: 450 lb. load for 25% of stroke | 760 lb. load for 50% of stroke | 200 lb. load for 25% of stroke

$$P_e = \sqrt[3]{\frac{25(450)^3 + 50(760)^3 + 25(200)^3}{100}}$$

Equivalent Load (P_e) = 625 lbs.

Life At Loads

(Other than Rated) Based on the inverse cube ratio in that by operating at 1/2 the rated load you will get 8 times the life or operating at twice the rated load you will get 1/8 the life.

$$(Rated\ Load / Actual\ Load)^3 * 10^6 = LIFE\ ASSEMBLY\ UNDER\ ACTUAL\ LOAD$$

Design Life Objective

Design Life Objective is the number of inches that a ball screw will travel during the desired life of the machine. Generally it is ultimately stated in terms of years of life but we need to compare inches of travel to inches of calculated life.

| | |
|---|----------------------------|
| Length of stroke | = 6 inches |
| Cycle rate of machine | = 20 Strokes/hr. |
| Hours of operation /day | = 16 hours |
| Number of working days per year | = 250 days |
| Number of years machine is designed for | = 5 years |
| $6 * 20 * 16 * 250 * 5$ | = 2,400,000 inches of life |

End Fixity

End Fixity (Bearing Mount Support Configuration) refers to the method by which the ends of the screws are supported. The end fixity basically describes the bearing configuration being used to support the rotational axis of the screw. The end fixity combinations are determined as a result of critical speed, column loading and system stiffness calculations. There are three basic end fixity styles that can be used in four combinations. The ends styles are "free" (no support), "Simple" (single point support) and "Fixed" (spaced support points).

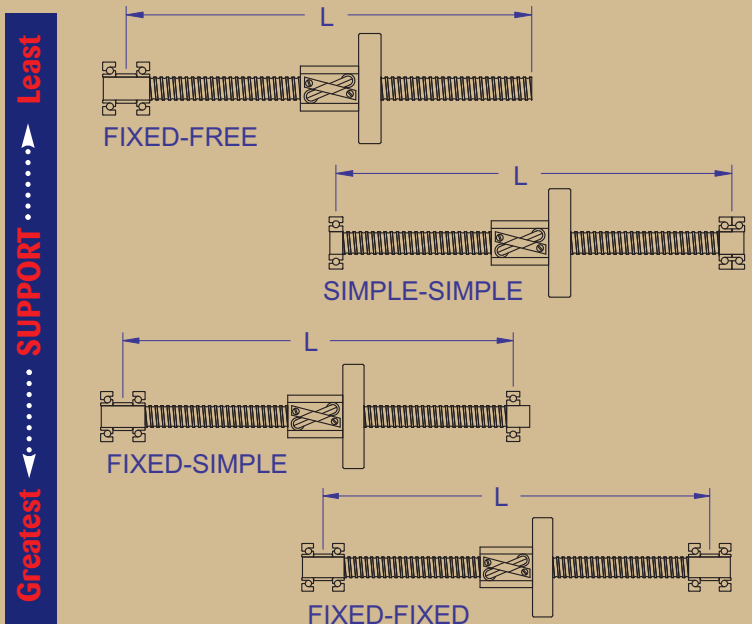

Critical Speed

Critical Speed is the theoretical linear velocity (inches per min.) which excites the natural frequency of the screw. As the speed of the screw approaches the natural frequency (critical speed), the screw shaft begins to resonate which leads to excessive vibration. The resulting resonance can occur regardless of whether the screw or nut rotates or regardless of screw orientation. R/B/S recommends limiting the maximum linear velocity to 80% of the calculated critical speed value.

$$C_s = \frac{F_e * 4.76 * 10^6 * D_{min} * S_L * F_s}{L^2}$$

- C_s = Critical Speed (Inches/min.)
- D_{min} = Minor Diameter (root) of Screw (In.)
- S_L = Screw Lead (In.)
- L = Distance between bearing supports
- F_e = End Fixity Variable
 - = .36 for Fixed-Free Support Configuration
 - = 1.00 for Simple-Simple Configuration
 - = 1.47 for Fixed-Simple Configuration
 - = 2.23 for Fixed-Fixed Configuration
- F_s = Factor of Safety (80% recommended)

Critical Ball Speed

(DN Value) is the critical ball velocity within the ball nut. Exceeding this value can setup vibrations within the ball screw assembly.

$$DN = (3000 / \text{Screw Nominal Diameter}) * \text{Lead}$$

Column Load Strength

Column Load Strength is the ability of the screw shaft to withstand compressive forces. The fundamental limit occurs when a compressive load exceeds the elastic stability of the screw shaft. Exceeding the column load will result in bending and buckling of the screw. This mode of failure can only occur when the screw shaft is in compression and never in tension. R/B/S recommends limiting the maximum compressive load to 80% of the calculated column load strength.

$$P_c = \frac{F_e * 14.03 * 10^6 * D_{min}^4 * F_s}{L^2}$$

- P_c = Maximum Column Load (lbs.)
- D_{min} = Minor Diameter (root) of Screw (In.)
- L = Distance (max.) between load and bearing in compression (inches)
- F_e = End Fixity Variable
 - = .25 for Fixed-Free Support Configuration
 - = 1.00 for Simple-Simple Configuration
 - = 2.00 for Fixed-Simple Configuration
 - = 4.00 for Fixed-Fixed Configuration
- F_s = Factor of Safety (80% recommended)

Drive Torque

Drive Torque is the amount of torque (inch pound) required by the ball screw to move the load. This torque does not take into account any inertial loading required for acceleration.

$$T_d = \frac{S_L * (P * \mu)}{2\pi \text{Eff}} = .177 * L * (P * \mu)$$

- T_d = Drive Torque (Inch pounds)
- P = Applied Dynamic Load (LBS)
- S_L = Lead of Screw (Inches)
- μ = Coefficient of Sliding Friction (=1 if load orientation is vertical)
- Eff = Ball Screw Efficiency (90%)

Coefficient of sliding friction for non-vertical loading applications:

- Steel on Steel ~.58
- Steel on Steel (greased) ~.15
- Aluminum on Steel ~.45
- Gibb Ways ~.50
- Dove Tail Slides ~.20
- Linear Bearing (Ball Bushings) <.001

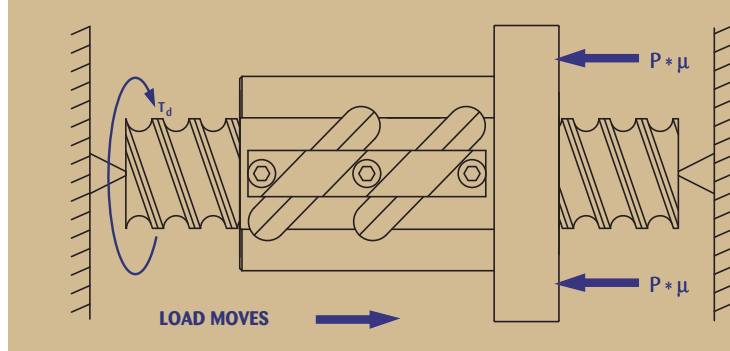

Back Drive Torque

The torque produced through the screw shaft by a thrust load on the ball nut. Ball screws can coast or backdrive due to the high efficiency of the mechanism (90%). If back driving is not acceptable, a method to resist the overturning backdriving systemic torque, such as a brake, will be required to hold the load. If backdriving is desired, the lead of the screw should be at least 1/3 of the screw diameter. Ideally the lead should be equal to the screw diameter. This calculated torque is the minimum amount of braking torque to hold the load in position.

$$T_b = \frac{S_L * P_t * \text{Eff}}{2\pi} = .143 * L * P_t$$

- T_b = Backdrive Torque (Inch pounds)
- P_t = Thrust Load applied to Nut (LBS)
- S_L = Lead of Screw (Inches)
- Eff = Ball Screw Efficiency (90%)

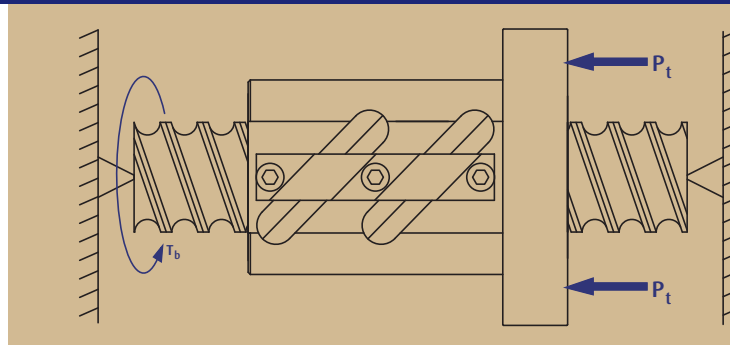

Preload Torque

The additional torque required to overcome the frictional components of the preload force. This additional torque (inch pounds) needs to be added to the drive torque in order to calculate the required torque for constant velocity.

$$T_p = \frac{S_L * P_{pl} * .2}{2\pi} = .032 * S_L * P_{pl}$$

- T_p = Preload Torque (Inch pounds)
- P_{pl} = Preload Setting (LBS)
- S_L = Lead of Screw (Inches)

Power Requirements

The power (HP) to drive a ball screw assembly is a function of required drive torque and motor R.P.M. Horsepower should be calculated based on the maximum torque required during the stroke or cycle. The highest torques generally are during acceleration due to inertial loading.

$$RPM = \frac{\text{Velocity (inches / min.)}}{\text{Lead (inches / rev.)}} \quad \text{Horsepower} = \frac{RPM * \text{Drive Torque (in.lbs)}}{63,000}$$

Materials and Hardness

Most screws and nuts are made from alloy steel and case hardened to Rc 56 minimum. Our stainless steel models are made of 17-4ph precipitation hardenable stainless steel with a surface hardness of Rc 38 minimum. Specialty materials can be supplied, contact factory.

Screw Straightness

Screw straightness is extremely important in minimizing screw vibration. Our ball screw stock is straight to .010" per foot not to exceed .025" over the entire length. We can hold straightness on machined screws to as little as .002"/foot (screw diameter and length dependent).

Temperature Range

Temperature range for our ball screws is between -65°F. (-54 C) and 300°F. (149 C) with suitable lubricants.

Lubrication

Lubrication is required to achieve optimum life for a ball screw assembly. Ball screws that are not lubricated can experience up to a 90% reduction in calculated life. In general, standard lubrication practices for anti-friction rolling element bearings apply. Grease, oil or dry film lubrication can be used. Many ball nuts are equipped with a 1/8-27NPT lube port machined into the nut body. For models that do not have a factory lube port, contact factory for recommendations on lubrication application.

See page 15 for Rockford Ball Screw Grease. This lubricant is specially formulated for use with ball screws as well as ACME screws and bearing mount assemblies. Rockford Ball Screw Grease is packaged in convenient 14 oz. grease cartridges.

Ball Screw Finish

Ball Screw Finish is a black oxide coating to help prevent corrosion during shipping and brief storage. Long term corrosion resistance is accomplished by the rust inhibiting properties of the screw lubricant. In applications with extreme environments, additional coatings such as nickel, hard chrome, zinc or other coatings can be applied. Contact Rockford Ball Screw for detailed specifications.

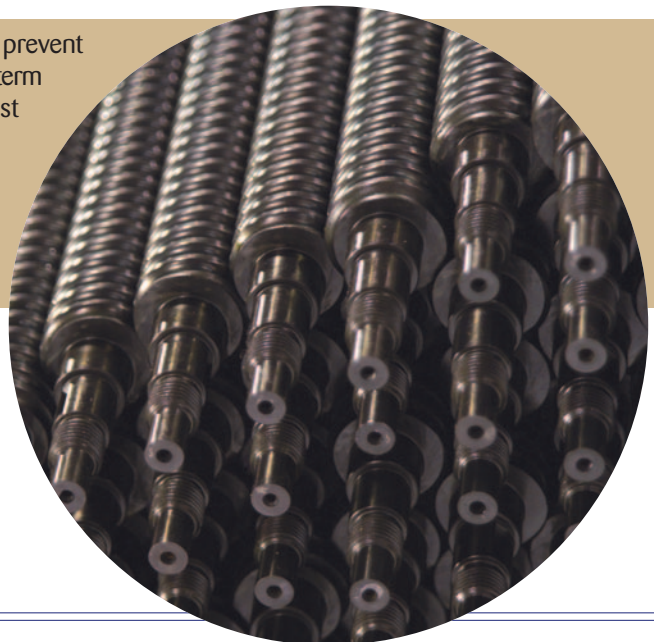

Wiper Kits

Wiper kits are available for all standard ball screw models. The nylon brush wiper is designed to keep large particulates from entering the ball nut. However for harsh environments, the use of boots or bellows to enclose the screw is recommended. Contact Rockford Ball Screw for further information on enclosures.

Our product pages detail the type of wiper mounting arrangement for each ball nut model. Brush wipers may require customer supplied retention primarily on the V-thread end of the ball nut (on models that do not have internal wipers and snap rings). A stamped flange retainer is available for many models that do not have internal snap rings for wiper retention (see data pages for available sizes).

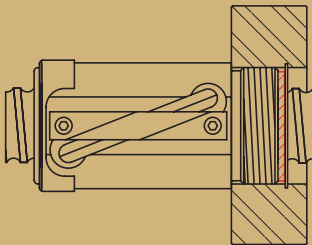

SNAP RING RETAINER
IN MATING PART

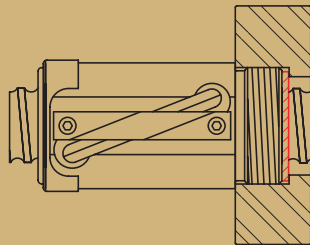

THREADED & C'BORED
MATING PART

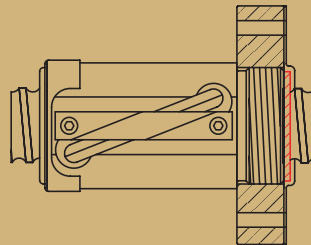

STAMPED FLANGE
WIPER PLATE

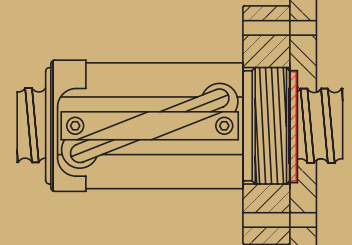

C'BORED WORKPIECE
FOR FLANGE ATTACHMENT

Mounting Flanges

If a mounting flange is used instead of the standard v-thread on the ball nut body, it must be permanently attached to prevent disengagement during operation. The two standard methods of retaining the flange is pinning and retaining with a set screw. Commercial thread locking adhesives may also be used (light loads only). It is always recommended that the flange pinning be performed at the factory to assure no metal chips are present after drilling.

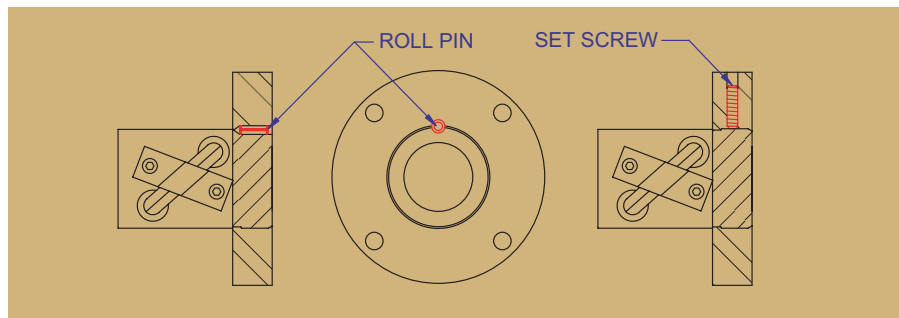

Flange Orientation

The orientation of the flange bolt holes to the return tube components varies with the number of holes in the flange. Unless otherwise specified, the following illustrations represent the standard orientations.

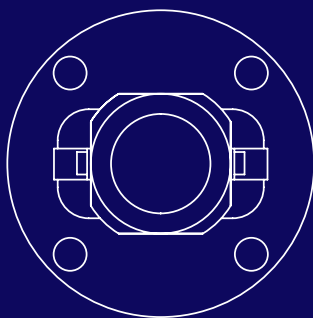

FOUR HOLE

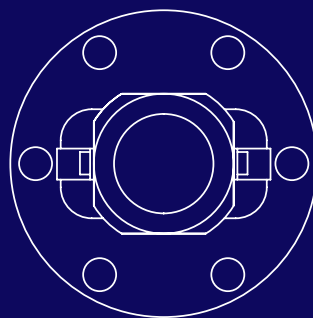

SIX HOLE

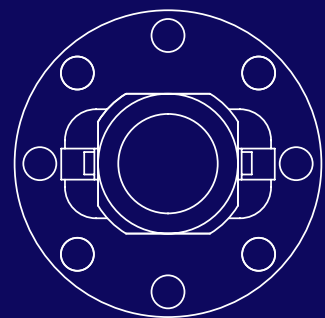

EIGHT HOLE

Safety Springs

The safety spring is a coiled spring installed in the inactive part of the ball nut and conforms to the ball screw thread. The spring is inactive during normal operation and does not contact the screw. In the rare event that the balls are lost from the ball nut, the safety spring will assume the load and prevent the nut from "free falling" down the screw. The spring is not designed to maintain normal operation and the ball screw assembly should be taken out of service after first engagement of spring. Safety springs are available for all ball screw models. The safety spring is mandatory if the screw is being used to lift, support or otherwise transport people. Please inform our customer representative that you require the safety spring for your particular application.



Free Wheeling Ball Screws

In addition to our full line of recirculating ball screws, we also offer a free-wheeling ball screw assembly (pages 58-59). The free wheeling screw (also referred to as planetary or epicyclic ball screws) is different from a standard ball screw in that it utilizes a ball cage (retainer) inside the nut. As the cage contacts the stop pins in the screw at the ends of the stroke, the ball nut will stop linear movement but the screw will continue to rotate (free-wheel). When the screw rotation reverses, linear motion occurs away from the stop pin and will travel until the cage contacts the pin at the other end of the stroke.

The advantage of the free wheeling screw is that limit switches or other types of stops are not necessary. This eliminates the possibility of over travel which can cause problems with many applications. The controlled stroke feature is used in many applications such as bed or chair actuations, trim tab actuators and electrical switching devices.

The free wheeling screw operates with the same efficiency (>90%) as a standard ball screw. Due to the planetary slipping of the nut in relation to the screw, there is an effective lead that is different than the actual lead of the screw. The effective lead is always less than the actual lead and varies with the direction and magnitude of the load (see pages 58-59). Since the lead is a variable, this device is not recommended for applications that rely on rotation of the screw for position feedback.





> Custom precision end machining is available for any specification.

Machined Ends

Rockford Ball Screw offers full service machining capabilities to supply screw assemblies that are ready for installation. We offer standard end machining that can accommodate our line of bearing mounts or we can machine ends to your specifications. See pages 80-85 for our standard end machining designs. Screws can also be supplied cut to length, it is recommended to have the screw ends factory annealed to assist in machining.

Custom Products/ Retrofits

Rockford Ball Screw has many years of experience in adapting and retrofitting ball and ACME screws into a wide array of applications. We offer engineering expertise to help with your application from inception through installation. Although we showcase numerous "standard" products in the following pages, we do many modifications and supply "specials" on a regular basis. Please feel free to contact our customer service or engineering personnel to discuss your requirements.

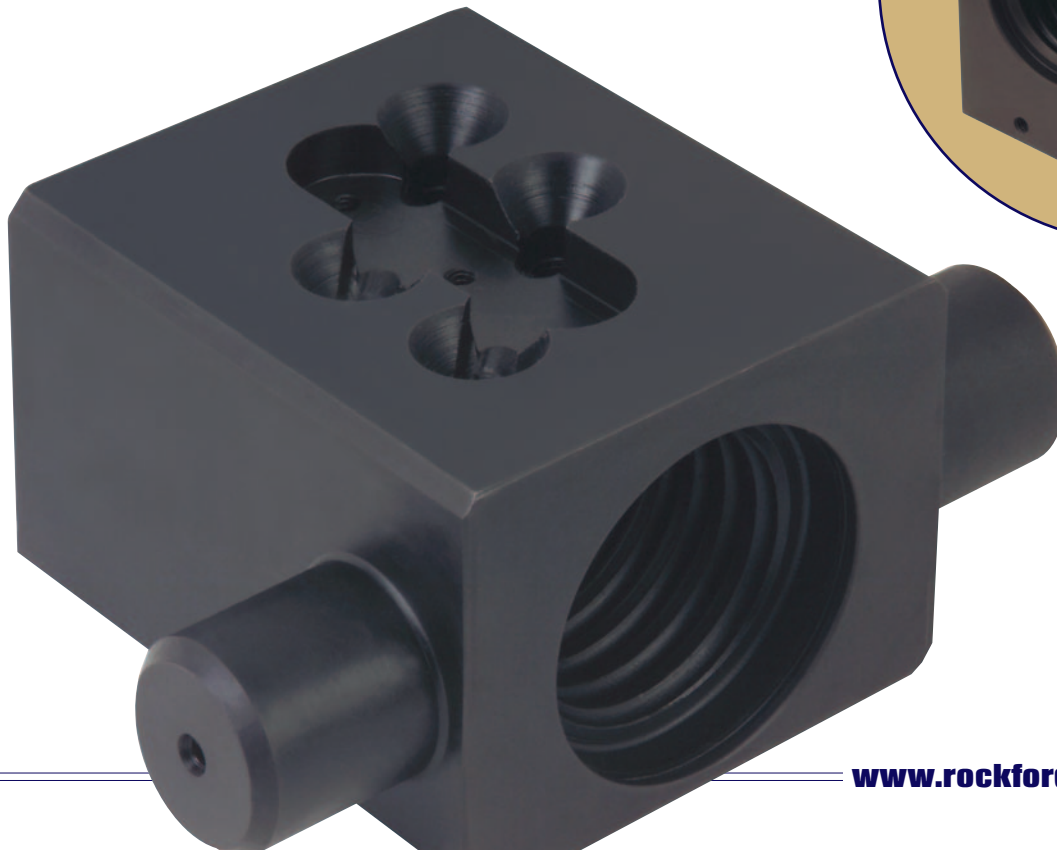
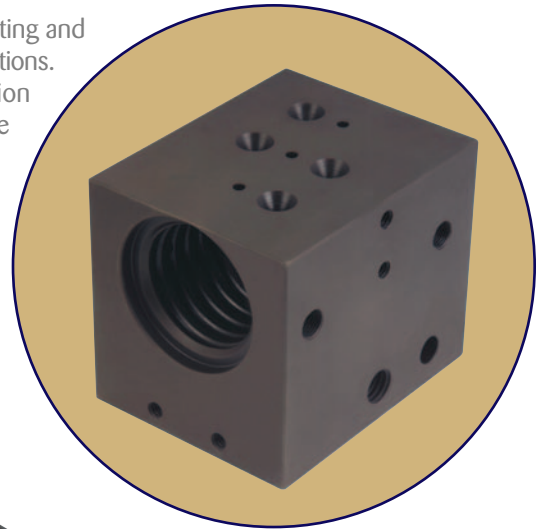

EFFECT OF CHANGE IN PARAMETER

| INCREASE IN | EFFECTS | HOW |
|------------------------------------|--|--|
| Screw Length | Critical Speed Column Load | Decreases Decreases |
| Screw Diameter | Critical Speed Inertia Stiffness Spring Rate Load Capacity Column Load | Increases Increases Increases Increases Increases Increases |
| Lead | Torque Input Load Capacity Positioning Accuracy Angular Velocity Ball Diameter | Increases Increases Decreases Decreases Increases |
| Angular Velocity | Critical Speed | Decreases |
| Mounting Rigidity | Critical Speed System Stiffness | Increases Increases |
| Load | Life | Decreases |
| Nut Length (7 1/2 Turn Max) | Load Capacity Stiffness | Increases Increases |
| Number of Balls | System Stiffness Load Capacity | Increases Increases |
| Preload | Positioning Accuracy System Stiffness Drag-Torque | Increases Increases Increases |
| Ball Diameter | Life Stiffness Load Capacity | Increases Increases Increases |



INVENTORY:

Rockford Ball Screw has been manufacturing ball screws, ACME screws and linear motion components since 1972. We pride ourselves in being able to respond to our customers' needs by maintaining one of the largest inventories of screws that are made entirely in the USA.

We stock in excess of 56 ball screw models, over 25 ACME screws sizes, many types of bearing mounts and other linear motion products. Many products are stocked in a variety of materials such as high and low carbon alloy steels and various grades of stainless steel.

We are equipped to supply your ball and ACME screw requirements with second to none service and delivery times.

In addition to our "Standard" inventory lines, we take pride in our specialty and custom designs.

Call us today and see for yourself what "service" really means.