



**RSF Elektronik**

**RELIABLE. SOPHISTICATED. FLEXIBLE.**

## **MSR 20, MSR 40**

Modular Rotary Encoder with Singlefield scanning

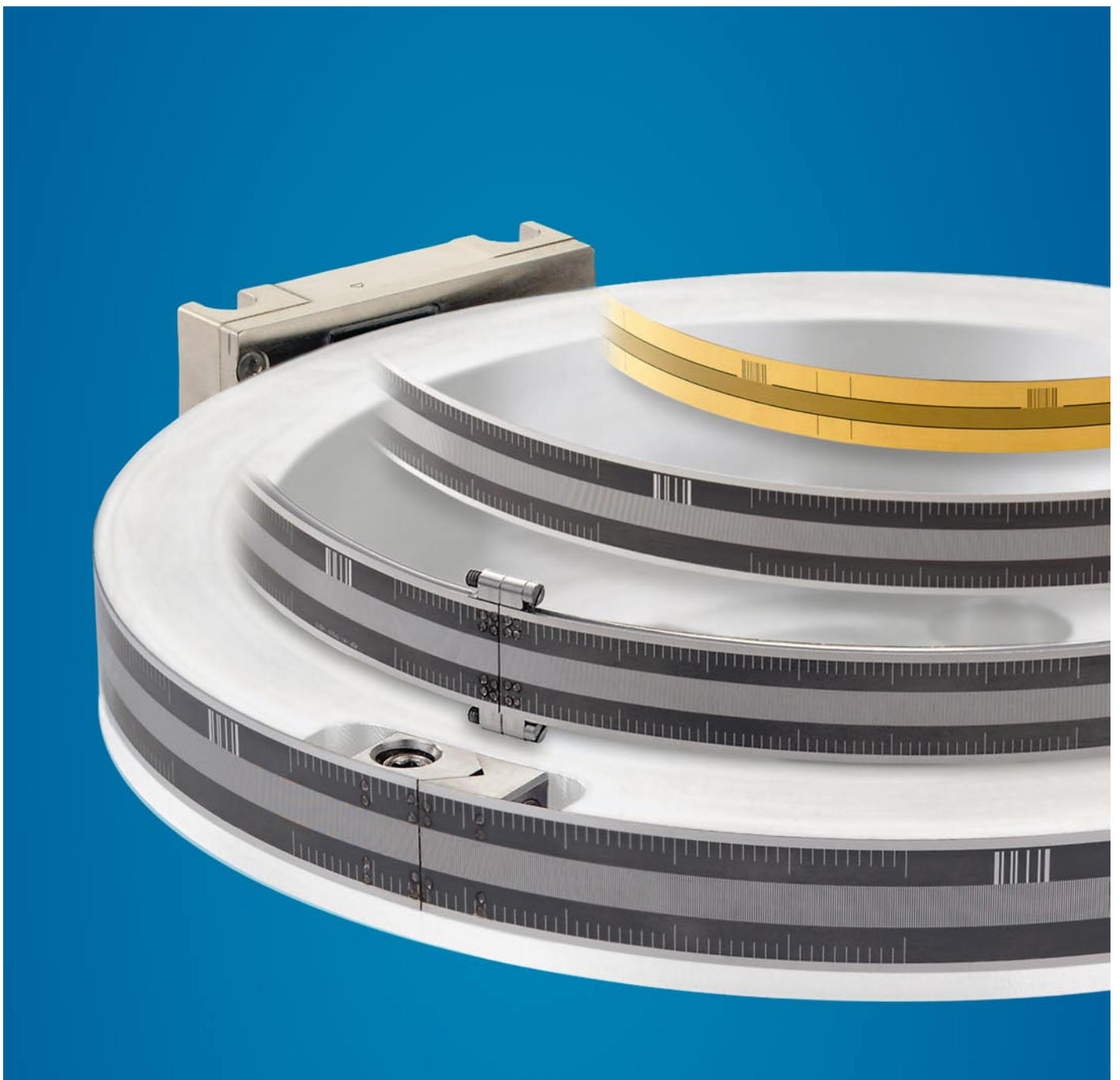

# Term-explanation

## Grating Pitch (Interval)

A grating is a continuous series of lines and spaces printed on the scale. The width of one line and one space is called the pitch (sometimes referred to as the interval) of the grating. The lines and spaces are accurately placed on the scale.

## Signal Period

When scanning the grating, the encoder head produces sinusoidal signals with a period equal to the grating pitch.

## Interpolation

The sinusoidal signal period can be electronically divided into equal parts. The interpolation circuitry generates a square wave edge for each division.

## Reference Pulse (Reference Mark)

There is an additional track of marks printed next to the grating to allow a user to find an absolute position along the length of the scale. A one increment wide signal is generated when the encoder head passes the reference mark on the scale.

This is called a “true” reference mark since it is repeatable in both directions. Subsequent electronics use this pulse to assign a preset value to the absolute reference mark position.

## Error Signal

This signal appears when a malfunctioning encoder generates faulty scanning signals.

## Measuring Step (Resolution)

The smallest digital counting step produced by an encoder.

## Line Rates

Number of the grating pitches per rotation.

## Accuracy

This is a fundamental characteristic, which is specified with an accuracy grade (e.g.  $\pm 5\mu\text{m}/\text{m}$ ).

## Yaw Angle, Pitch Angle, Roll Angle, Lateral, Airgap

Mounting tolerances of the encoder head relative to the scale.

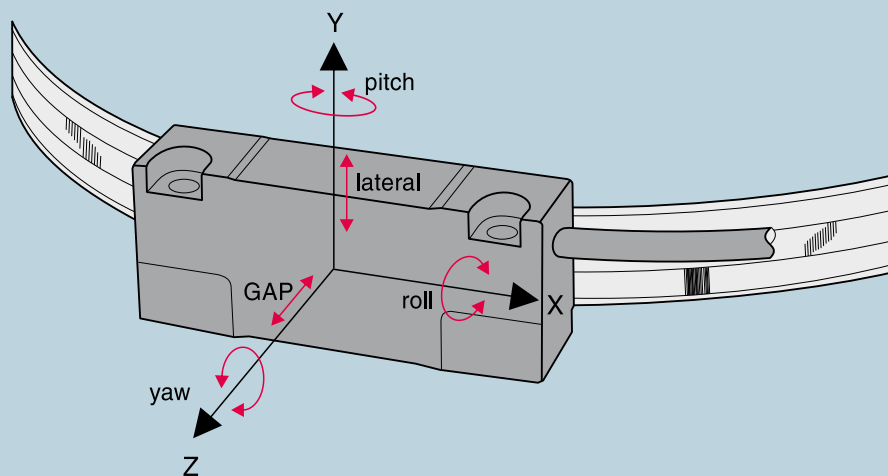

---

## What design characteristics do you require in an modular Rotary Encoder

- small dimensions
- high contamination resistance
- high resolution
- high circumferential speed
- large mounting tolerances

### The new MSR meets all these requirements!

The trend today in motion control applications is for open Encoder Systems.

This is driven by steadily increasing demands for

- Higher circumferential speed
- Higher operating cycles
- Zero frictional force induced by the encoder.

Only open, non-contact encoders fulfill all these requirements.

A drawback of many open linear encoders is their sensitivity to dirt and contamination on the scale.

The MSR encoder's unique optical design minimizes the effect of dirt and contamination normally associated with the Open Linear Encoders.

The MSR utilizes a unique scanning principle which allows for high traversing speeds (up to 15 m/s), large mounting tolerances and contamination on the scale.

Reference marks, accurate and repeatable from both circumferential directions, are standard.

A wide range of interpolation electronics, integrated into the encoder head, enables resolutions from 10  $\mu\text{m}$  to 0,1  $\mu\text{m}$ . Squarewave signals, single ended, or via Line Driver RS 422, are provided at the output of the encoder head.

Units with sinusoidal outputs 1Vpp are also available.

Due to recent advancements in technology, all of these benefits are now available in a small package design.

# Scanning principle

The model MSR x0 modular Rotary Encoder works with the imaging, photoelectric measuring principle and a **singlefield reflective scanning** method. A scale graduation pattern with 200 µm (MSR 40) resp. 40 µm (MSR 20) grating pitch is used on a steel tape.

The light from an infrared LED with a small light emitting surface is collimated parallel by a condenser lens and directed through the scanning reticle to the scale. When the scale is moved relative to the encoder head, the light is modulated by the scale gratings and produces a periodic intensity signal that is converted into electrical signals by photo elements back in the encoder head.

The scanning reticle is designed to allow for a large mounting gap and liberal mounting tolerances. This system is insensitive to waviness of the steel tape due to poor mounting conditions. Any minor differences in the grating period of the scale or the scanning reticle will not cause a measuring problem due to the large continuous pattern reflected onto the structured sensor.

This sensor consists of multiple photo elements connected in a pattern to generate four sinusoidal signals, each shifted by 90°. All four signals are generated from one scanning field and all four signals are equally influenced by any contamination simultaneously. When all four signals are influenced at the same time by the same amount, interpolation error is eliminated.

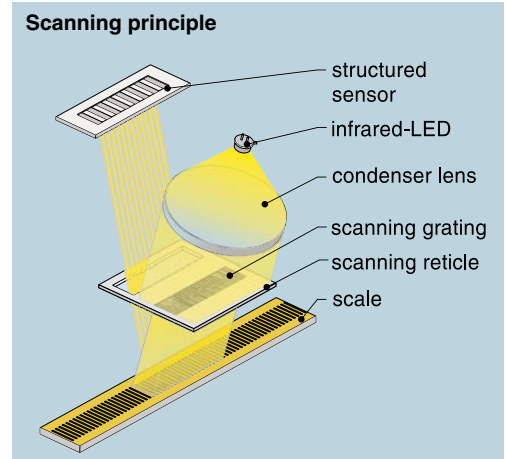

## Effect of contamination on the quality and size of the scanning signal (before interpolation)

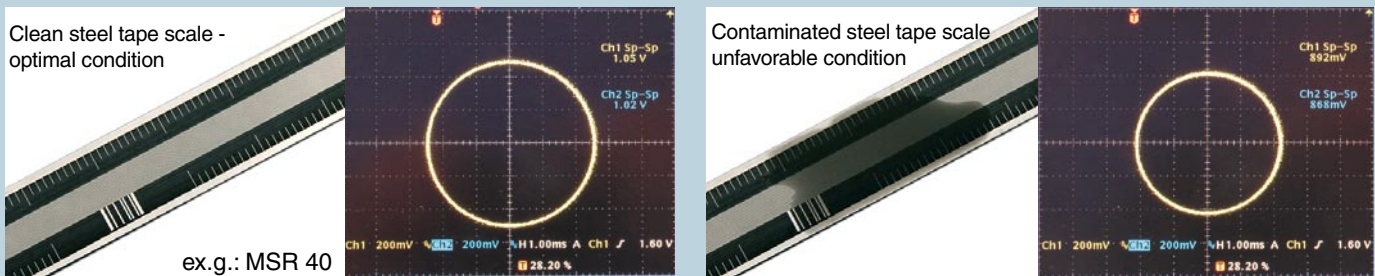

High insensitivity to contamination by use of a new scanning principle.

# Cable and connector shielding, standard connector pin outs

Encoder head shielding and cable type is determined by the signal type.

The standard is a 3 meter cable with a PUR jacket material.

Cables for use in vacuum applications to 10<sup>-7</sup> torr are also available upon request.

### Square wave signals Sinusoidal voltage signals

Single shielded cable, standard, Ø 4.3 mm  
permissible bending radii: fixed mounting 25 mm, continuous flexing 45 mm  
(typical 50 x 10<sup>9</sup> bending cycles)  
The connector must be connected to protective ground

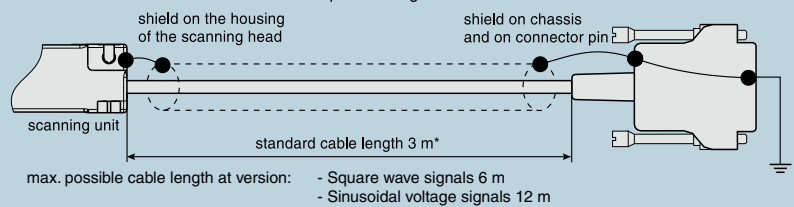

### Connector LD15 15-pin

PIN	1	2	3	4	5	6	7	8	9	10	11	12	13	14	15
Square wave signals via Line Driver	nc	GND	Us	RI	T2	T1	+5 V	+5 V	GND	nc	nc	RI	T2	T1	Shield
Voltage signals	nc	GND	nc	RI	A2	A1	+5 V	+5 V	GND	nc	nc	RI	A2	A1	Shield

- The shield is connected with the chassis

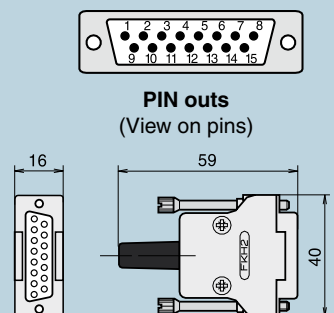

# Output signals

**Sinusoidal voltage signals** (drawing shows "positive rotation direction")  
 Two sinusoidal voltage signals A1 and A2 and one reference mark signal (all with inverted signals).

- Power supply: +5V ±5%, max. 130mA (unloaded)
- Reference voltage of the output signals: V+/2 (approx. 2.5 V)
- Track signals (differential voltage A1 to  $\bar{A}1$  resp. A2 to  $\bar{A}2$ ): Phaseshift  $90^\circ \pm 10^\circ$  el.
- Signal amplitude 0.6 Vpp to 1.2 Vpp
- typ. 1 Vpp with terminating impedance  $Z_0 = 120 \Omega$
- Reference Mark (differential voltage RI to  $\bar{R}I$ ): El. position typical  $135^\circ$  (referenced to A1)
- El. width typical  $360^\circ$
- Useable component 0.2 up to 0.85 V, typical 0.5 V with terminating impedance  $Z_0 = 120 \Omega$

**Advantage:**  
 - High traversing speed with long cable lengths possible

**Square wave signals** (drawing shows "positive rotation direction")  
 With interpolation electronics (for times 5, -10, -50 or -100) the photoelement output signals are converted into two square wave signals that have a phase shift of  $90^\circ$ .  
 Output signals either can be single ended or Line Driver differential (RS 422).  
 For measuring systems with single ended output signals the max. cable length is 10 m, including extension cable  
 One measuring step reflects the measuring distance between two edges of the square wave signals.

The controls/DRO's must be able to detect each edge of the square wave signals.  
 The minimum edge separation  $a_{min}$  is listed in the technical data and refers to a measurement at the output of the interpolator (inside the scanning head).  
 Propagation-time differences in the Line Driver, the cable and the Line Receiver reduce the edge separation.

- Propagation-time differences:**
- Line Driver: max. 10 ns
  - Cable: 0.2 ns per meter
  - Line Receiver: max. 10 ns referred to the recommended Line Receiver circuit

To prevent counting errors, the controls/DRO's must be able to process the resulting edge separation.

**Example:**  
 $a_{min} = 100 \text{ ns}$ , 10 m cable  
 The control/DRO must be able to detect  $100\text{ns} - 10\text{ns} - 10 \times 0.2\text{ns} - 10\text{ns} = 78\text{ns}$

**Power supply:** +5 V ±5%, max. 165 mA (unloaded)

**Advantage:**  
 - Noise immune signals  
 - No further subdividing electronics necessary

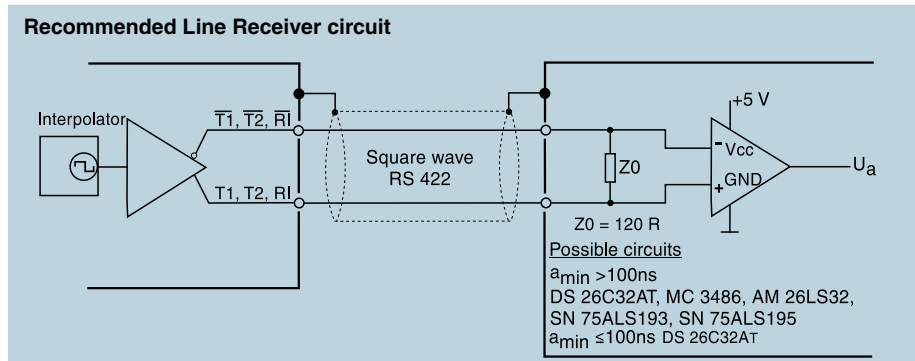
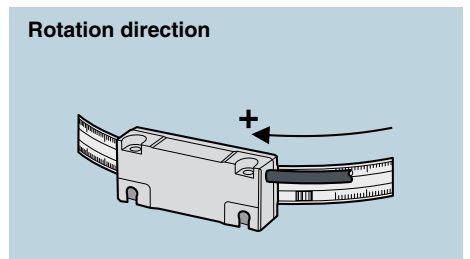
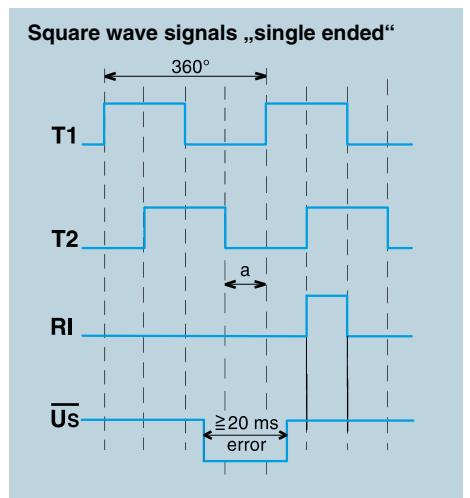
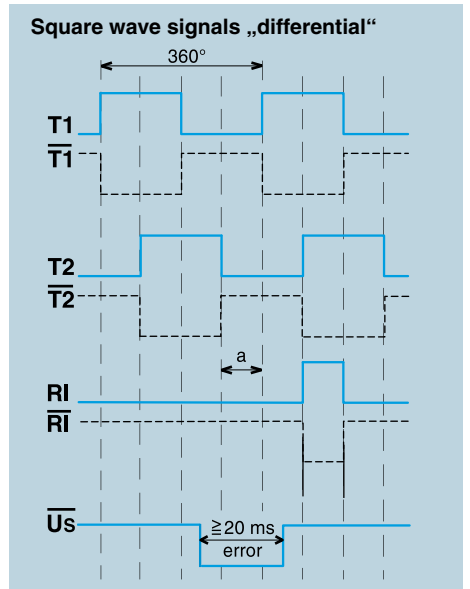
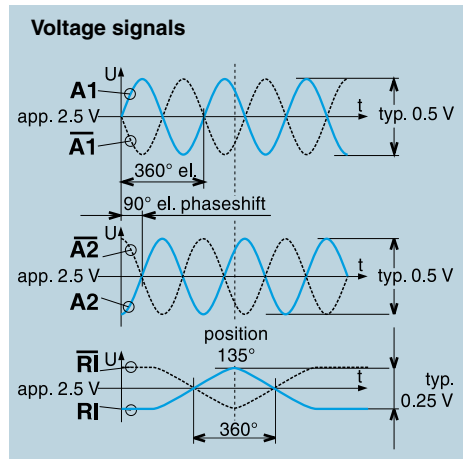

# MSR 20 MKS

## Technical data

### Special highlights:

- Segment version
- Steel tape scale with adhesive tape
- Grating pitch 40 µm
- Easy mounting as a result of large mounting tolerances
- High circumferential speed
- Integrated subdividing electronics up to times 100



Scale model	Grating pitch	integrated interpolation	max. circumferential speed	max. output frequency resp. edge separation a <sub>min</sub>
<b>• Sinusoidal voltage signals</b>				
<b>MSR 20.04</b>	40 µm	-	10 m/s	250 kHz
<b>• Square wave signals via Line Driver with integrated subdividing</b>				
<b>MSR 20.64</b>	40 µm	times 5	6,4 m/s	300 ns
<b>MSR 20.74</b>	40 µm	times 10	3,2 m/s	300 ns
<b>MSR 20.44</b>	40 µm	times 20	2.4 m/s	200 ns
<b>MSR 20.54</b>	40 µm	times 25	1.9 m/s	200 ns
<b>MSR 20.84</b>	40 µm	times 50	1.9 m/s	100 ns
<b>MSR 20.94</b>	40 µm	times 100	0.96 m/s	100 ns

Scale unit: MKS = steel tape scale with adhesive tape

Possible shaft diameters: Ø ≤ 50 - 400 mm, scale-segment pre-bended in factory over Ø 400 mm on request, scale-segment is not pre-bended

Reference mark (RI): any position, additional reference marks separated by n x 50 mm

Accuracy of the grating pitch (stretched): ±15 µm/m

Mounting control: electronical signal test/set-up boxes PG-x resp. PS4

Operating temperature range: 0°C up to +50°C (coefficient of expansion of the shaft between  $9 \times 10^{-6} \text{ K}^{-1}$  and  $12 \times 10^{-6} \text{ K}^{-1}$ )

Temperature range of storage: -20°C up to +70°C

Weight depending (approx.): 30 g (scanning unit without cable), 20 g/m (steel tape scale)

Mounting aid: optional accessory

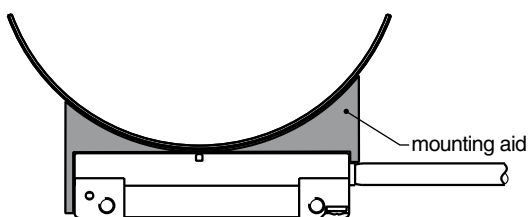

# Dimensions, mounting tolerances, mounting possibilities

adjust to max. signal or RI-position

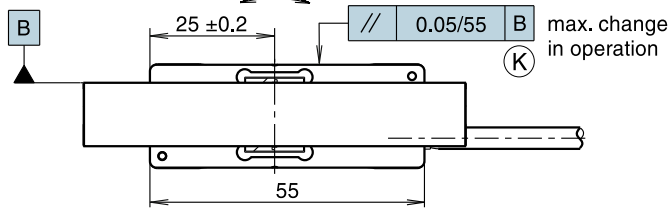

steel scale (developed length)

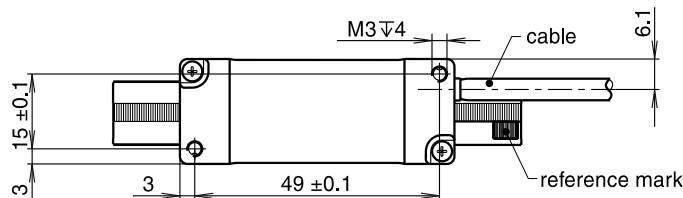
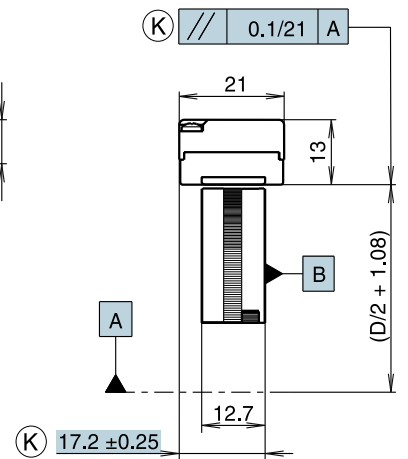
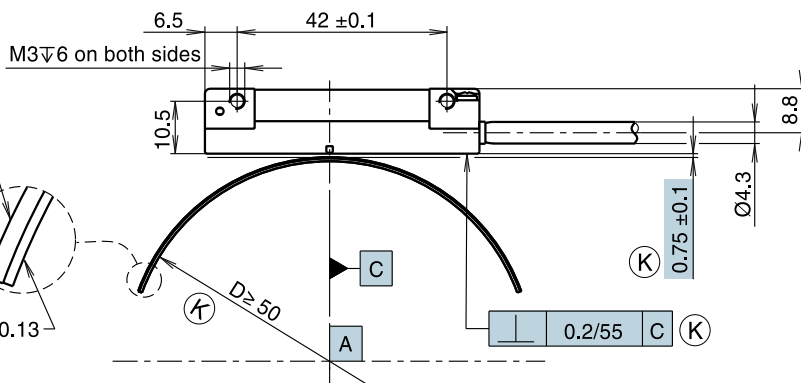
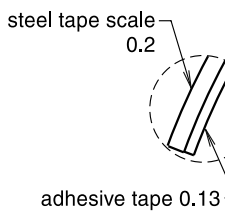
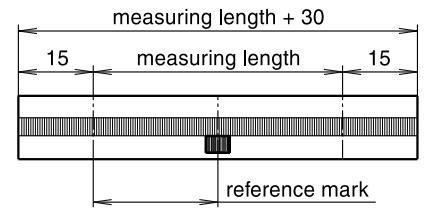

(K) = required mating dimensions  
 D = shaft diameter  
 reference mark (RI):  
 any position, additional reference marks  
 separated by  $n \times 50$  mm

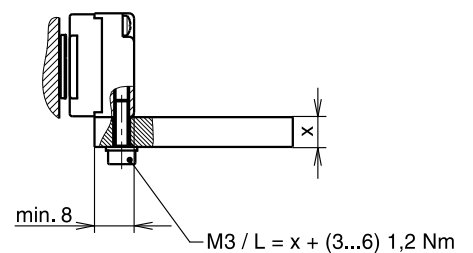
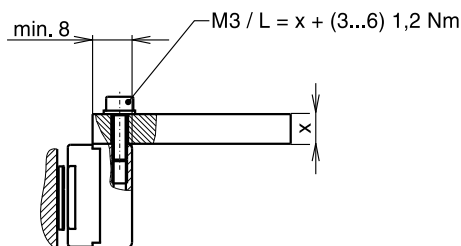
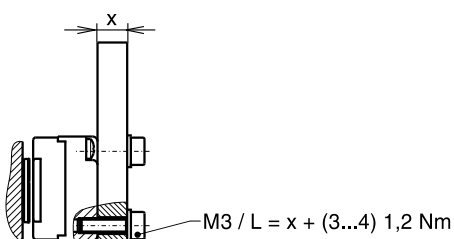





# MSR 40 MOR

## Technical data

### Special highlights:

- Full-circle version with clamping element
- Steel tape scale
- Grating pitch 200 µm
- Easy mounting as a result of large mounting tolerances
- High rotational speed
- Integrated subdividing electronics up to times 100



Scale model		MSR 40.06	MSR 40.66	MSR 40.76	MSR 40.86	MSR 40.96	
System resolution [°]		dep. on external interpolation	360° Lines x 20	360° Lines x 40	360° Lines x 200	360° Lines x 400	
System resolution [µm]		dep. on external interpolation	10	5	1	0.5	
Signal form		1 Vpp					
Integrated interpolation		-	times 5	times 10	times 50	times 100	
Max. output frequency		90 KHz	-	-	-	-	
Edge separation a <sub>min</sub>		-	500 ns	500 ns	200 ns	200 ns	
Lines	Shaft diameter mm	System accuracy *	max. rot. speed [min <sup>-1</sup> ]	max. rot. speed [min <sup>-1</sup> ]	max. rot. speed [min <sup>-1</sup> ]	max. rot. speed [min <sup>-1</sup> ]	max. rot. speed [min <sup>-1</sup> ]
2400	152.70	±80"	200	200	200	200	200
2500	159.07	±80"	200	200	200	200	200
3600	229.15	±60"	200	200	200	200	200
5000	318.34	±40"	200	200	200	200	144
7200	458.50	±30"	200	200	200	200	100
10000	636.88	±20"	150	150	150	144	72
10800	687.85	±20"	139	139	139	133	67
14400	91719	±15"	104	104	104	100	50
18000	1146.54	±15"	83	83	83	80	40

\* without mounting, additional deviations as a result of mounting and storage of the measured shaft, are not respected.

Further line rates or higher rotational speed on request

Scale unit: MOR = steel tape scale with clamping element

Reference mark (RI): 25 mm from scale-joint (see drawing), additional reference marks separated by n x 100 mm

Accuracy of the grating pitch (stretched): ±30 µm/m

Mounting control: electronical signal test/set-up boxes PG-x resp. PS4

Operating temperature range: 0°C up to +50°C (coefficient of expansion of the shaft between 9 x 10<sup>-6</sup> K<sup>-1</sup> and 12 x 10<sup>-6</sup> K<sup>-1</sup>)

Temperature range of storage: -20°C up to +70°C

Weight depending (approx.): 17 g (scanning unit without cable), 20 g/m (steel tape scale), 12 g (clamping element)

Mounting aid: optional accessory

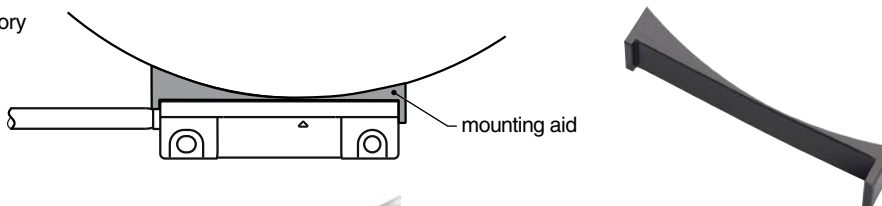

Installation kit: optional accessory





# Dimensions, mounting tolerances, mounting possibilities

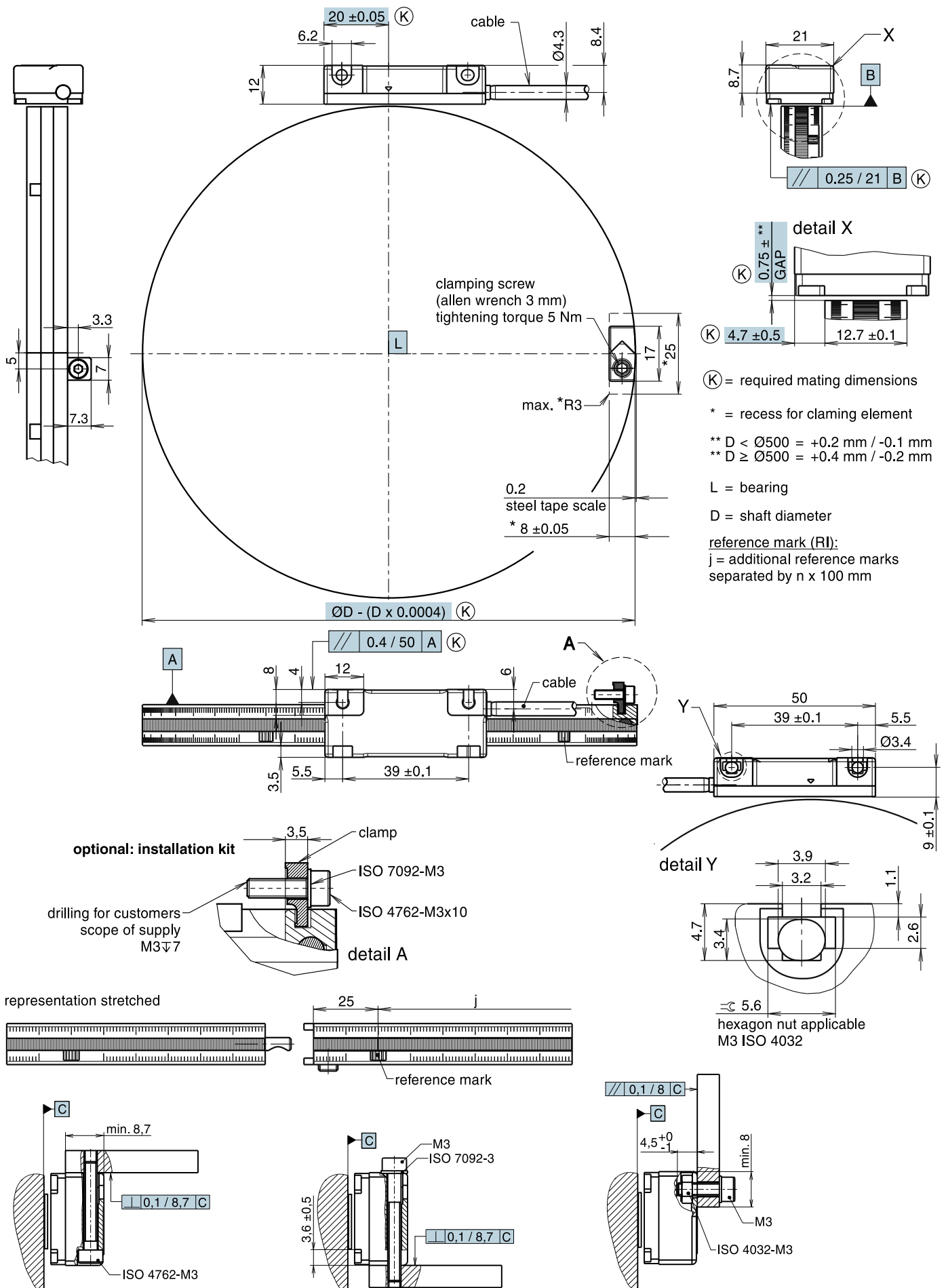





# MSR 40 MER

## Technical data

### Special highlights:

- Full-circle version with clamping element
- Steel tape scale with elastic layer compensates  $\varnothing$ -change of the shaft  
( $\Delta D_{\max.} \pm 0,2 \text{ mm}$ )
- Grating pitch 200  $\mu\text{m}$
- Easy mounting as a result of large mounting tolerances
- High rotational speed
- Integrated subdividing electronics up to times 100



Scale model			MSR 40.06	MSR 40.66	MSR 40.76	MSR 40.86	MSR 40.96
System resolution [°]			dep. on external interpolation	360° Lines x 20	360° Lines x 40	360° Lines x 200	360° Lines x 400
System resolution [ $\mu\text{m}$ ]			dep. on external interpolation	10	5	1	0.5
Signal form			1 V <sub>SS</sub>				
Integrated interpolation			-	times 5	times 10	times 50	times 100
Max. output frequency			90 KHz	-	-	-	-
Edge separation a <sub>min</sub>			-	500 ns	500 ns	200 ns	200 ns
Lines	Shaft diameter mm	System accuracy *	max. rot. speed [min <sup>-1</sup> ]	max. rot. speed [min <sup>-1</sup> ]	max. rot. speed [min <sup>-1</sup> ]	max. rot. speed [min <sup>-1</sup> ]	max. rot. speed [min <sup>-1</sup> ]
2 400	146.99	±400 $\mu$	200	200	200	200	200
2 500	153.35	±350 $\mu$	200	200	200	200	200
3 600	223.38	±250 $\mu$	200	200	200	200	200
5 000	312.51	±200 $\mu$	200	200	200	200	144
7 200	452.57	±150 $\mu$	200	200	200	200	100
10 000	630.82	±100 $\mu$	150	150	150	144	72
10 800	681.75	±100 $\mu$	139	139	139	133	67
14 400	910.93	±75 $\mu$	104	104	104	100	50
18 000	1 140.12	±50 $\mu$	83	83	83	80	40
20 000	1 267.44	±50 $\mu$	75	75	75	72	36

\* without mounting, additional deviations as a result of mounting and storage of the measured shaft, are not respected.

Further line rates or higher rotational speed on request

Scale unit: MER = steel tape scale with elastic layer and clamping element

Reference mark (RI): 25 mm from scale-joint (see drawing), additional reference marks separated by n x 100 mm

Accuracy of the grating pitch (stretched): ±30  $\mu\text{m}/\text{m}$

Mounting control: electronical signal test/set-up boxes PG-x resp. PS4

Operating temperature range scanning unit: 0°C bis +50°C

Operating temperature range scale unit: range of temperature is dependent on the coefficient of the expansion of the shaft.

Max.  $\varnothing$  difference of the shaft to steel tape scale  $\Delta D \pm 0.2 \text{ mm}$  (steel tape scale  $\alpha = 10.5 \times 10^{-6} \text{ K}^{-1}$ ).

Temperature range og storage: -20°C up to +70°C

Weight depending (approx.): 17 g (scanning unit without cable), 45 g/m (steel tape scale with elastic layer), 2.5 g (clamping element)

Mounting aid: optional accessory

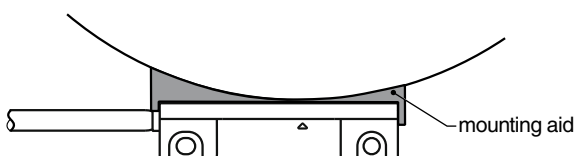

# Dimensions, mounting tolerances, mounting possibilities

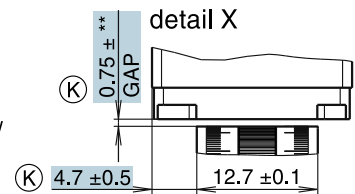
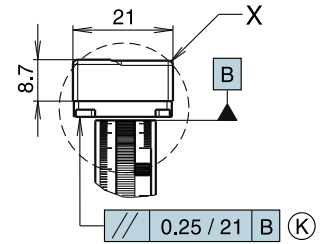
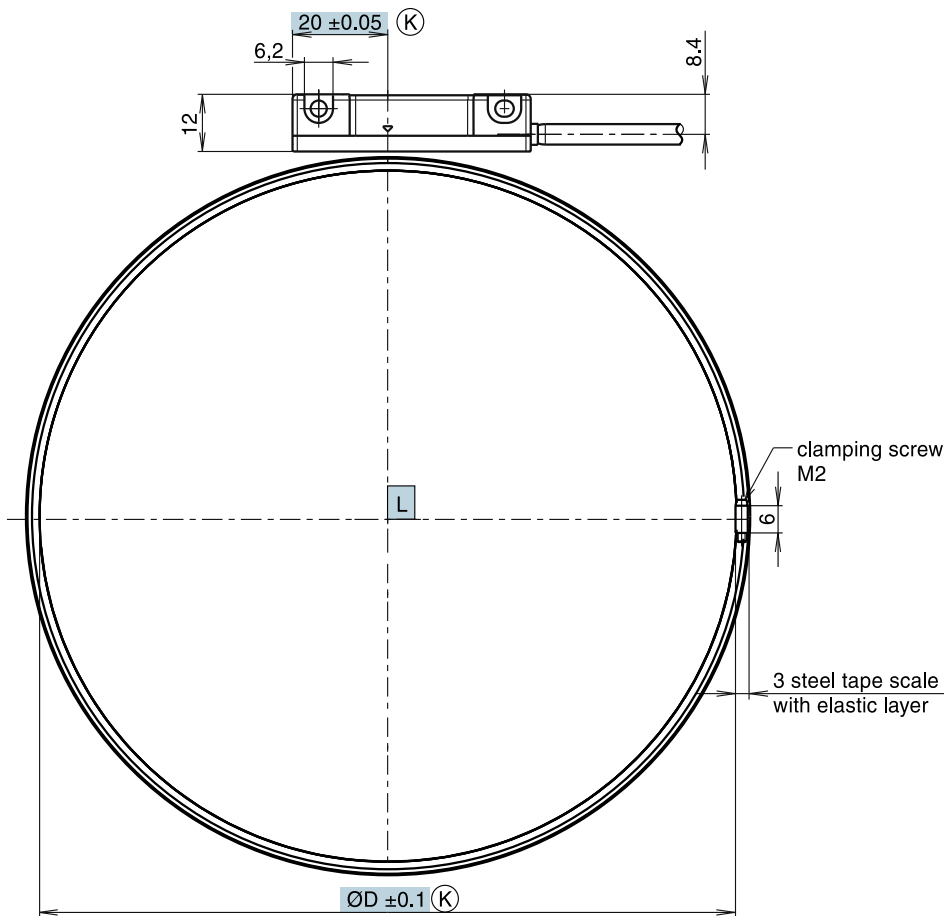

(K) = required mating dimensions

\*\* D < Ø500 = +0.2 mm / -0.1 mm  
 \*\* D ≥ Ø500 = +0.4 mm / -0.2 mm

L = bearing

D = shaft diameter

reference mark:

j = additional reference marks separated by n x 100 mm

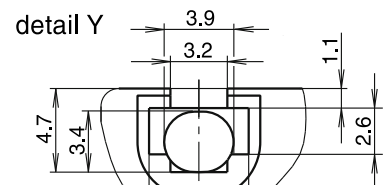
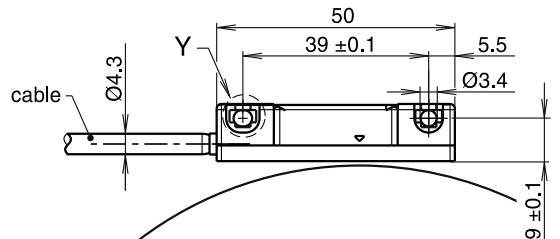
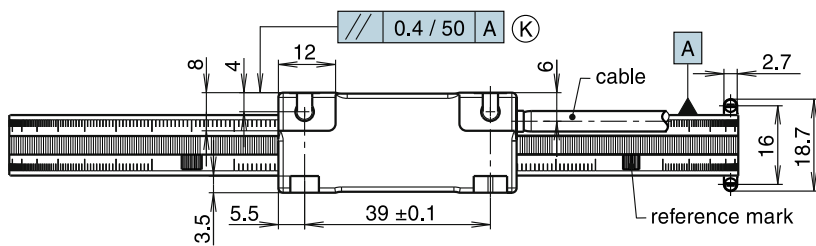

hexagon nut applicable  
 M3 ISO 4032

representation stretched

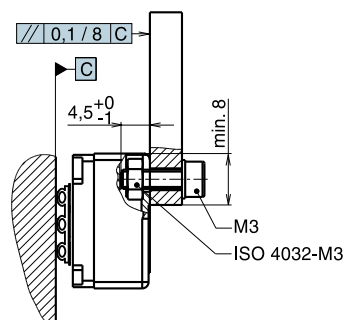
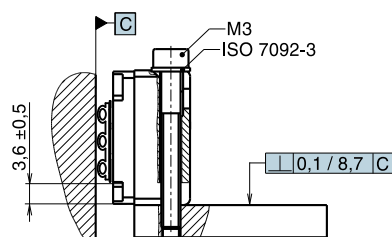
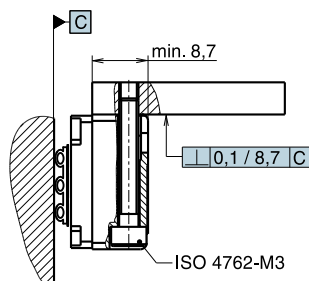
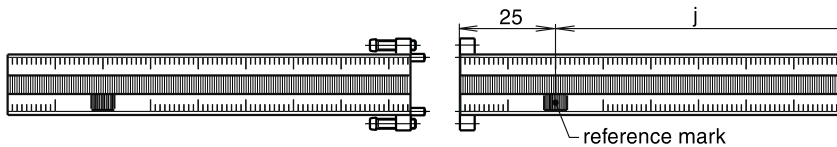

# MSR 40 MKS

# Technical data

**Special highlights:**

- Segment version
- Steel tape scale with adhesive tape
- Grating pitch: 200 µm
- Easy mounting as a result of adhesive tape
- High circumferential speed
- Integrated subdividing electronics up to times 100



Scale model	Grating pitch	Integrated interpolation	Max. circumferential speed	Max. output frequency resp. edge separation $a_{min}$
• Sinusoidal voltage signals				
<b>MSR 40.06</b>	200 µm	-	15 m/s	75 kHz
• Square wave signals via Line Driver with Subdividing				
<b>MSR 40.66</b>	200 µm	times 5	15 m/s	500 ns
<b>MSR 40.76</b>	200 µm	times 10	9.6 m/s	500 ns
<b>MSR 40.86</b>	200 µm	times 50	4.8 m/s	200 ns
<b>MSR 40.96</b>	200 µm	times 100	2.4 m/s	200 ns

Scale unit: MKS = steel tape scale with adhesive tape

Possible shaft diameters:  $\varnothing \leq 150 - 400$  mm, scale-segment pre-bended in factory over 400 mm, scale-segment is not pre-bended

Reference mark (RI): 25 mm from the beginning of measuring range (see drawing), additional reference marks separated by  $n \times 100$  mm

Accuracy of the grating pitch (stretched):  $\pm 30$  µm/m

Mounting control: electronical signal test/set-up boxes PG-x resp. PS4

Operating temperature range: 0°C up to +50°C

Temperature range of storage: -20°C up to +70°C

Weight depending (approx.): 17 g (scanning unit without cable), 25 g/m (steel tape scale with adhesive tape)

Mounting aid: optional accessory

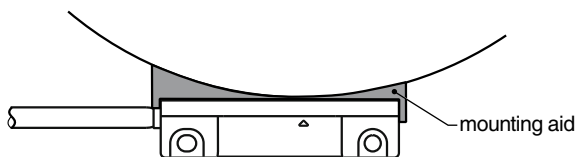

# Dimensions, mounting tolerances, mounting possibilities

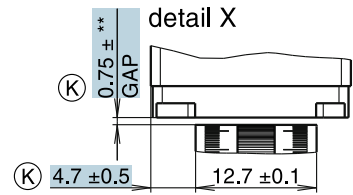
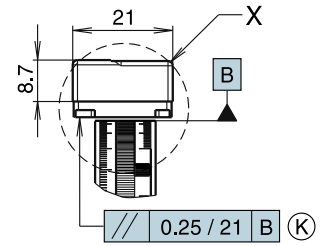
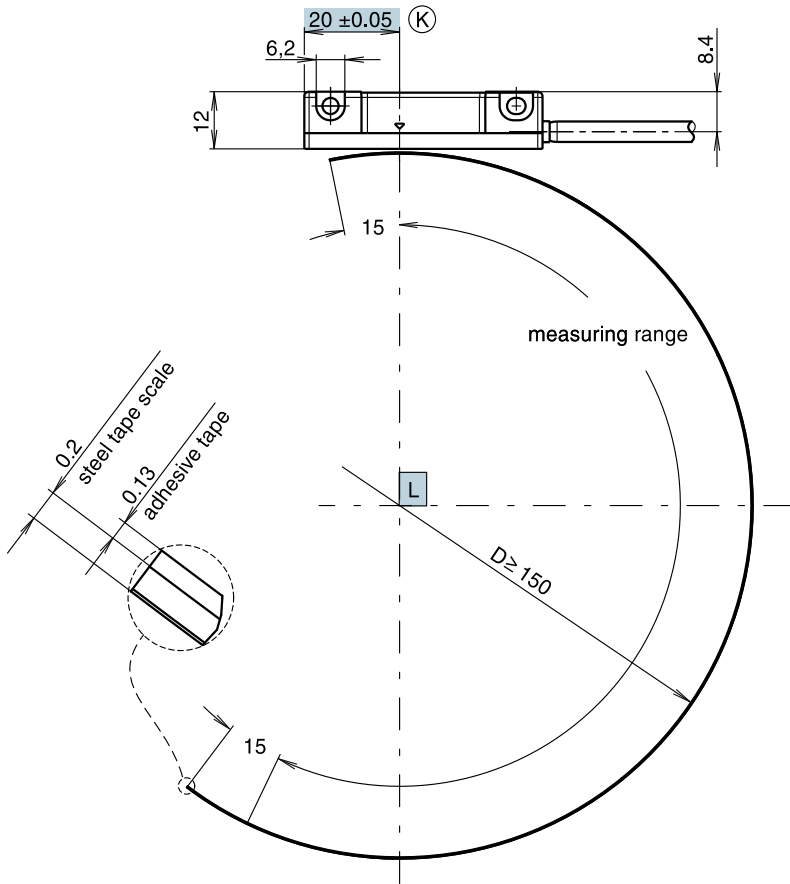

- (K) = required mating dimensions
- \*\* D < Ø500 = +0.2 mm / -0.1 mm
- \*\* D ≥ Ø500 = +0.4 mm / -0.2 mm
- L = bearing
- D = shaft diameter
- reference mark:  
j = additional reference marks separated by n x 100 mm

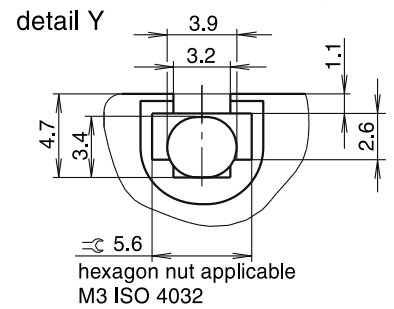
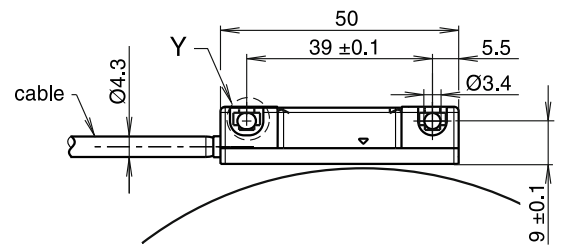
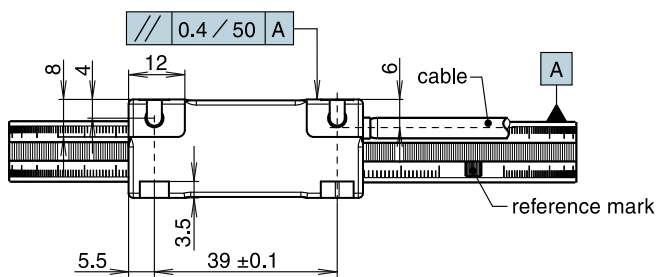

representation stretched

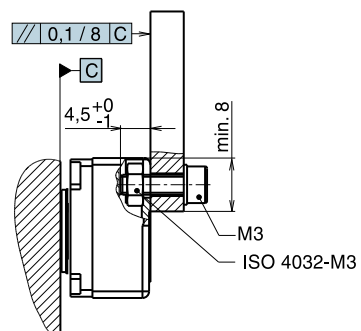
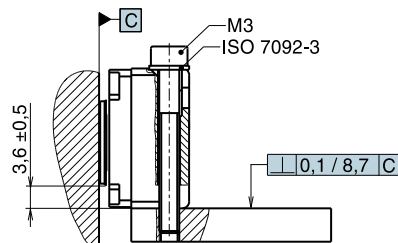
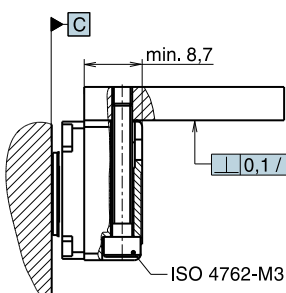
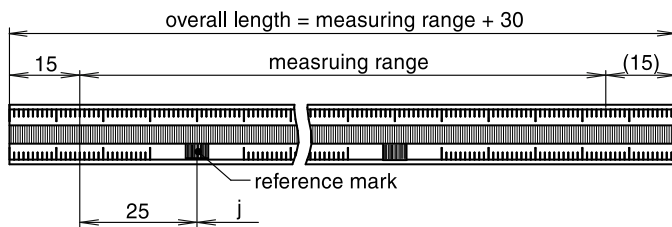

# PG electronic signal test/set-up boxes for MSR 20

Open Linear Encoders are adjusted at the factory to provide optimal signals at the specified mounting conditions.

Even though the Linear Encoders in the MSR 20 series allow for large mechanical mounting tolerances, it is recommended to inspect the mounting by checking the quality of the output signals.

There are various methods of checking the quality of the output signals.

The signals can be connected to an oscilloscope and checked for conformity with signal specifications. This method requires effort, training and expensive test equipment (oscilloscope). Often one or all of these items are unavailable to the installing technician.

As an alternative to this method, RSF offers different signal test boxes. With these test boxes all encoder signals can be quickly and easily checked.

The **PG1-I / PG1-U** is an all-purpose signal test box where all the relevant signals are displayed on LCD Bars. The **PG1-I / PG1-U** allows the quantitative as well as the qualitative evaluation of the encoder signals.

The **PG2-I / PG-U** test box checks all relevant signals; amplitude, phase and offset, and displays the results in a **qualitative** format on a polychromatic LED display.

PG1-I / PG1-U



PG2

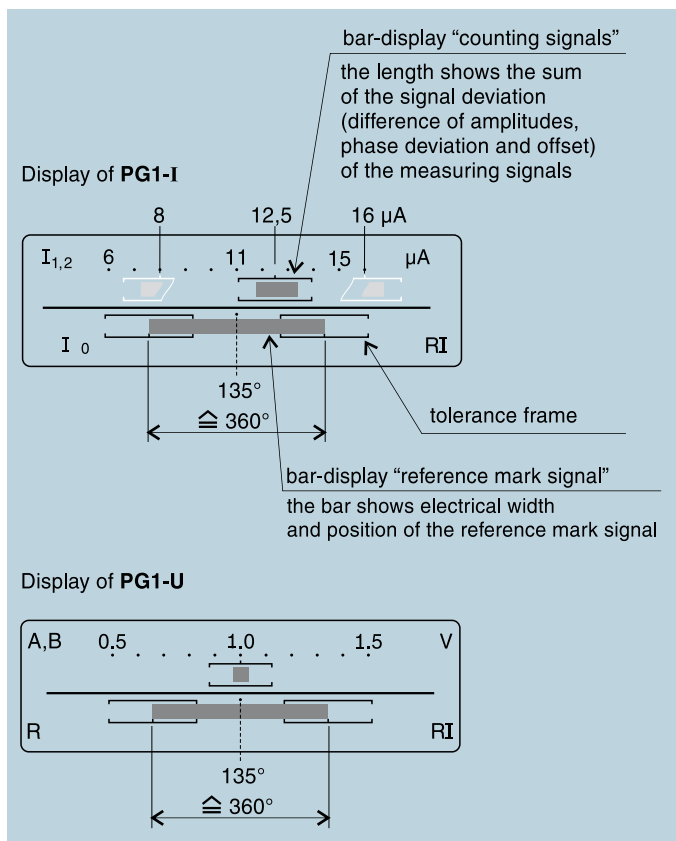

Intended PG-use	MSR 20, Output signals	
	square wave	sinus (1 Vpp)
PG1-I	✓	--
PG1-U	--	✓
PG2-I	✓	--
PG-U	--	✓

# PG, PS electronic signal test/set-up boxes for MSR 40

Open linear encoders are adjusted at the factory to provide the signal specifications at the specified mounting conditions.

Even though the linear encoders in the MSR 40 series allow for large mechanical mounting tolerances, it is recommended to inspect the mounting by checking the quality of the output signals.

There are various methods of checking the quality of the output signals.

The signals can be connected to an oscilloscope and checked for conformity with signal specifications. This method requires effort, training and expensive test equipment (oscilloscope). Often one or all of these items are unavailable to the installing technician.

As an alternative to this method, RSF offers different signal test boxes. With these test boxes all encoder signals can be quickly and easily checked.

The **PG1-U** is an all-purpose signal test box where all the relevant signals are displayed on LCD Bars.





The **PG1-U** allows the quantitative as well as the qualitative evaluation of the encoder signals.

The **PG-U**, **PG4** and **PS4** test box checks all relevant signals; amplitude, phase and offset, and displays the results in a **qualitative** format on a polychromatic LED display.

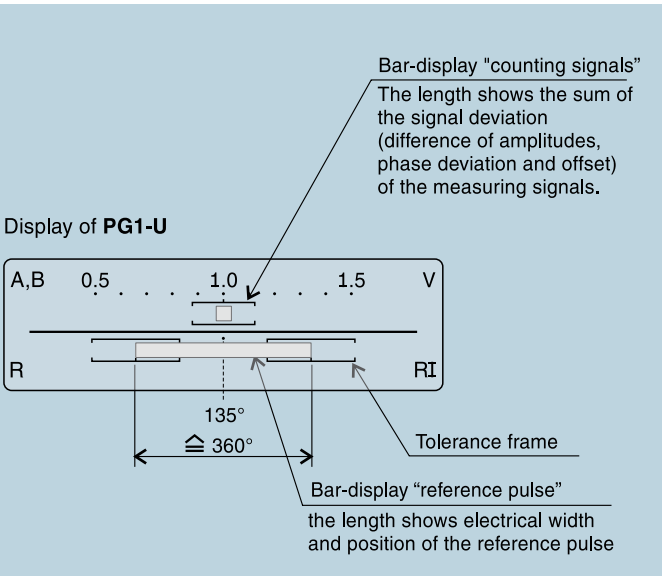
**PG-U** and **PG4** = stand alone test

**PS4** = in-circuit test



Intended PG-use	MSR 40 Output signals	
	square wave	sinus (1 Vpp)
PG1-U 	--	✓
PG-U 	--	✓
PG4 	✓	--
PS4 	✓	--

## Distribution contacts

**Austria** | RSF Elektronik Ges.m.b.H.  
A-5121 Tarsdorf  
☎ +43 (0) 6278 / 8192-0  
☒ +43 (0) 6278 / 8192-79  
e-mail: info@rsf.at  
internet: www.rsf.at

**USA** | HEIDENHAIN CORPORATION  
333 East State Parkway  
Schaumburg, IL 60173-5337  
☎ +1 847 490 - 1191  
e-mail: info@heidenhain.com  
internet: www.rsf.net

**Switzerland** | RSF Elektronik (Schweiz) AG  
Mülistrasse 18  
CH-8320 Fehraltorf  
☎ +41 (0) 44 955 10 50  
☒ +41 (0) 44 955 10 51  
e-mail: info@rsf.ch  
internet: www.rsf.ch

**China** | RSF Elektronik GmbH  
Tian Wei San Jie,  
Area A, Beijing Tianzhu Airport Industrial Zone  
Shunyi District  
101312 Beijing  
P.R. China  
☎ +86-10-8042-0288  
☒ +86-10-8042-0290  
e-mail: cao.shizhi@rsf.cn  
internet: www.rsf.cn

**Slovenia** | RSF Elektronik prodaja, d.o.o.  
Jozeta Jame 14  
SI-1210 Ljubljana  
☎ +386 1 519 88 80  
☒ +386 1 519 88 80  
e-mail: mail@rsf-elektronik.si

**Korea** | HEIDENHAIN LTD.  
201 Namsung Plaza, 9<sup>th</sup> Ace Techno Tower,  
345-30, Gasan-Dong, Geumcheon-Gu,  
Seoul, Korea 153-782  
☎ +82-2-2028-7430  
e-mail: info@heidenhain.co.kr  
internet: www.rsf.co.kr

Date 12/2009 • Art.No. 728692-21 • Technical adjustments in reserve!



**RSF Elektronik**  
Ges.m.b.H.

Precision Linear Scales  
Digital Readouts  
Industrial Electronics  
Precision Graduations

Certified according to  
DIN EN ISO 9001  
DIN EN ISO 14001

✉ **A-5121 Tarsdorf** • ☎ +43 (0)6278 / 8192-0 • ☒ +43 (0)6278 / 8192-79 • e-mail: info@rsf.at • internet: www.rsf.at