



RSF Elektronik

RELIABLE. SOPHISTICATED. FLEXIBLE.

MS 3x Series

Open Linear Encoders
with Singlefield Scanning

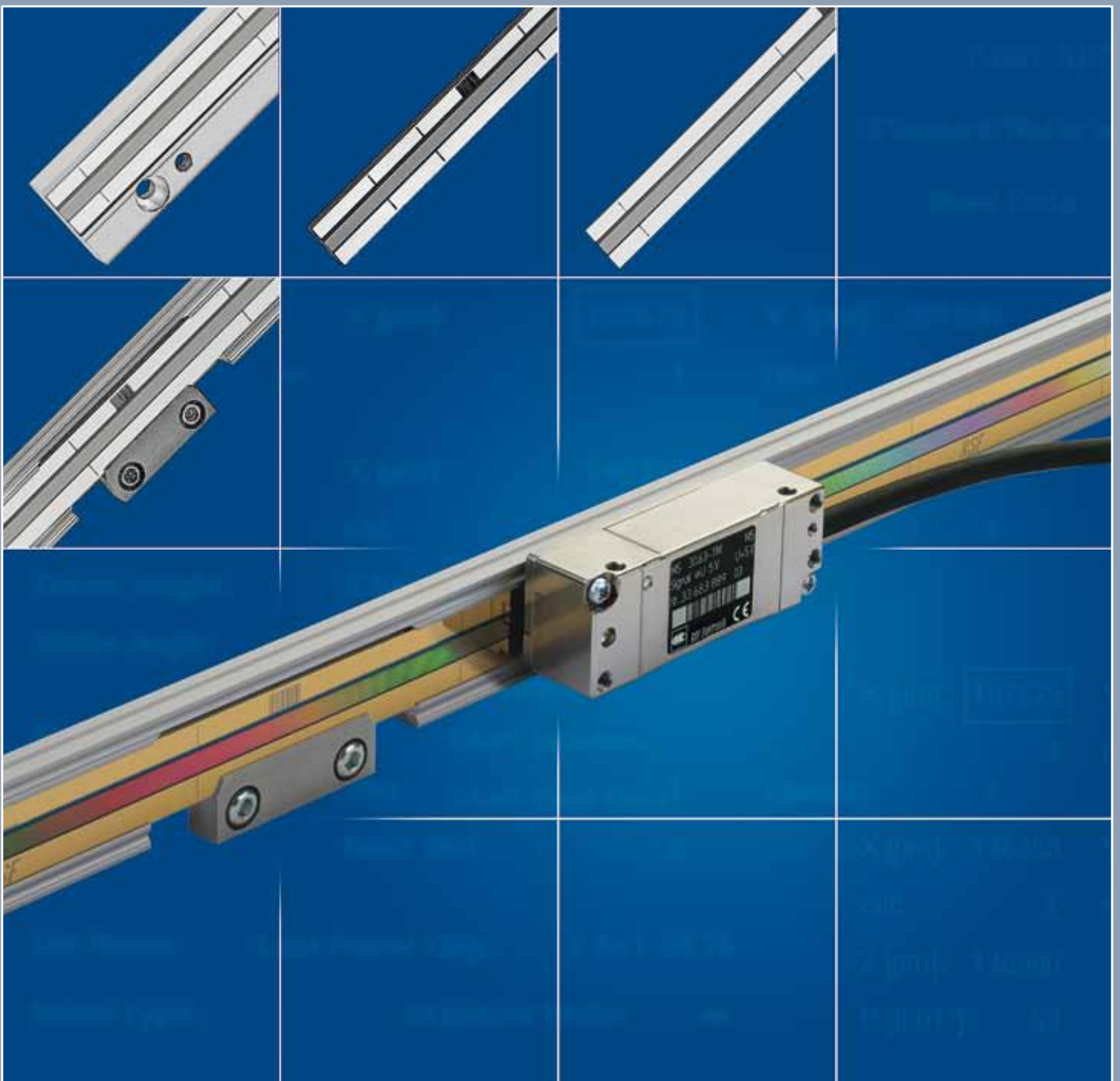

Contents

Description of Operating Principles / Design Advantages	03	MS 3x MP	12
Scanning Principle	04	MS 3x MT	13
Shielding, Pin Assignments	05	MS 3x GK	14
Output Signals	06	MS 3x GA	15
Switch Signal Output	07	Switch Points, Reference Mark (RI)-select	16
Features, Technical Data	08–09	Accuracy	17
MS 3x MO, MS 3x MK	10	Accessories: Electronic Signal Test/Set-up Boxes	18
MS 3x MA, MS 3x MS	11	Product Directory	19
		Distribution Contacts, Adresses	20

Term-explanations

Grating Pitch (Interval)

A grating is a continuous series of lines and spaces printed on the scale. The width of one line and one space is called the pitch (sometimes referred to as the interval) of the grating. The lines and spaces are accurately placed on the scale.

Signal Period

When scanning the grating, the encoder head produces sinusoidal signals with a period equal to the grating pitch.

Interpolation

The sinusoidal signal period can be electronically divided into equal parts. The interpolation circuitry generates a square-wave edge for each division.

Measuring Step (Resolution)

The smallest digital counting step produced by an encoder.

Reference Pulse (Reference Mark)

There is an additional track of marks printed next to the grating to allow a user to find an absolute position along the length of the scale. A one increment wide signal is generated when

the encoder head passes the reference mark on the scale. This is called a “true” reference mark since it is repeatable in both directions. Subsequent electronics use this pulse to assign a preset value to the absolute reference mark position.

Error Signal

This signal appears when a malfunctioning encoder generates faulty scanning signals.

Accuracy

This is a fundamental characteristic, which is specified with an accuracy grade (e.g. $\pm 5 \mu\text{m/m}$).

Abbe Error

Measuring error due to lateral distance between the measuring system and the machining level.

Yaw Angle, Pitch Angle, Roll Angle, Lateral Shift, Airgap

Mounting tolerances of the encoder head relative to the scale.

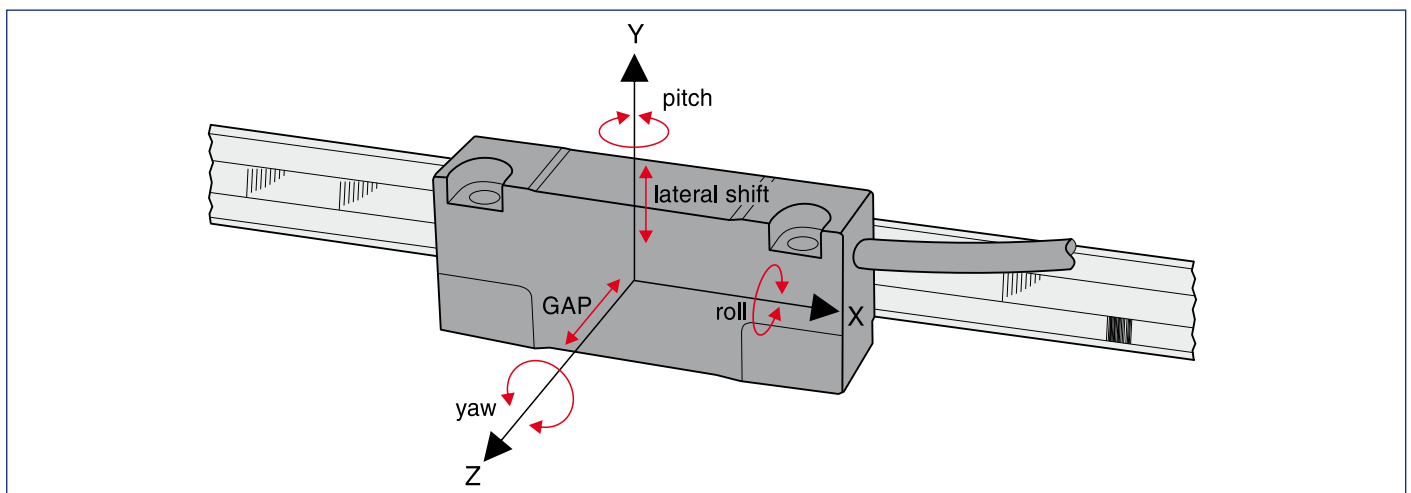

What do you require in an Open Linear Encoder?

- Contamination resistance
- Immunity against aging and temperature changes
- High resolution
- High traversing speed
- Large mounting tolerances
- Small dimensions

The MS 3x series meets all these requirements!

The trend today in motion control applications is for open Linear Encoder systems.

This is driven by steadily increasing demands for

- higher traversing speed
- higher operating cycles
- lower mechanical backlash
- zero frictional force induced by the encoder.

Only open, non-contact encoders fulfill all these requirements.

It is important for high resolution applications to minimize interpolation errors. Historically, the small grating periods used had the disadvantages of smaller mounting gaps and very tight overall mounting tolerances. The MS 3x encoders' 20 µm grating period minimizes interpolation errors but can be mounted with a large mounting gap and liberal mounting tolerances.

A drawback of many open Linear Encoders is their sensitivity to dirt and contamination on the scale.

The MS 3x encoders' unique optical design minimizes the effect of dirt and contamination normally associated with the open Linear Encoders.

The MS 3x utilizes a unique scanning principle which allows high traversing speeds (up to 7 m/s), large mounting tolerances, and contamination on the scale.

Reference marks, accurate and repeatable from both traversing directions, are standard.

A wide range of interpolation electronics, integrated into the encoder head, enable resolutions from 5 µm to 50 nm. Square-wave signals, single ended, or via Line Driver RS 422, are provided at the output of the encoder head.

Units with sinusoidal output, 1 Vpp, are also available.

Two end of travel optical switch signals are available directly out of the reading head. The end of travel signal locations can be easily set by the user.

Due to recent advancements in technology, all of these benefits are now available in a small package design.

Signal amplitude vs. reading head gap

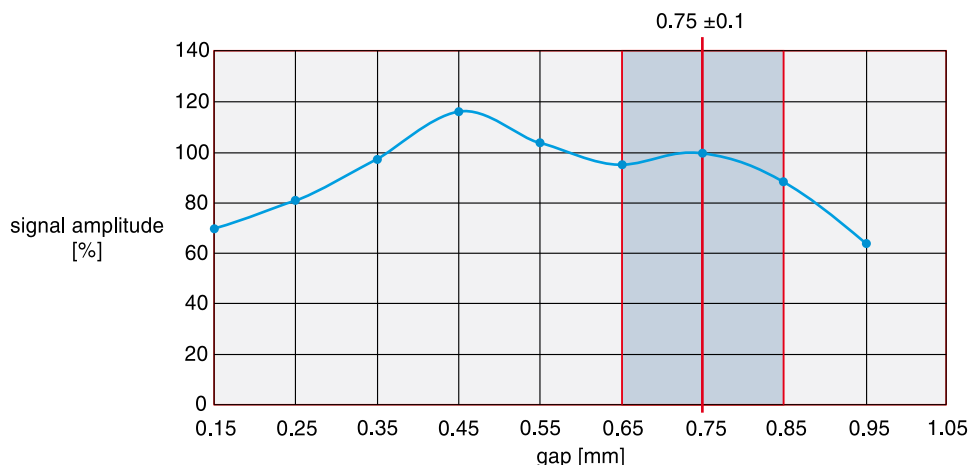

Scanning Principle

The model MS 3x incremental Linear Encoder works with the imaging, photoelectric measuring principle and a **singlefield reflective scanning** method.

The regulated light of an infrared LED is collimated by a condenser lens and passes through the grid of the reticle. After being reflected from the scale the infrared LED generates a periodic intensity distribution on the structured sensor.

The sensor generates high quality sinusoidal signals which are highly insensitive to possible contaminations.

The regulation of the LED ensures a constant light output, guaranteeing stability in the case of temperature fluctuations as well as with long-run operation.

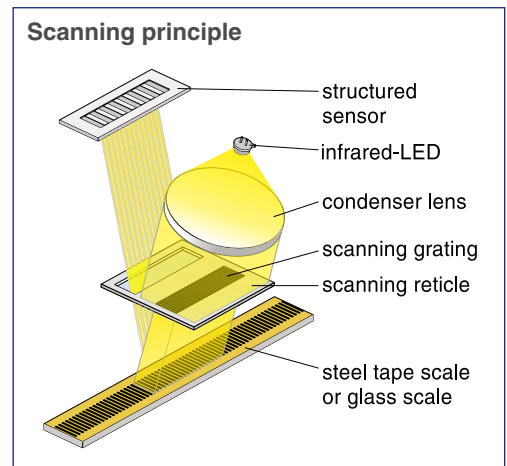

Effect of contamination on the quality and size of the measuring signal



High insensitivity to contamination by use of a new scanning principle.

A high accuracy grating is deployed as scale graduation with 20 µm grating pitch. Depending on the model, glass (chrome grating) ($\alpha \approx 8,5 \times 10^{-6}/K$), glass ceramic (—, —) ($\alpha \approx 0 \times 10^{-6}/K$) or steel (gold grating) ($\alpha \approx 10,5 \times 10^{-6}/K$) is employed as base.

The grating is the consistent series of lines and spaces of the same width. The width of one line and one space is called a grating pitch (T).

Parallel to the grating, there are one or more reference marks (RI) on a second track. Within the measuring length, any position is possible and additional reference marks can be chosen in a distance of 50 mm.

Linear Encoders with a suffix "K" in the model designation are equipped with distance-coded reference marks. After traveling a distance of 40 mm at maximum, the absolute tool position is available with these models. By dint of the optical scanning, a position-accurate evaluation of the reference marks is ensured.

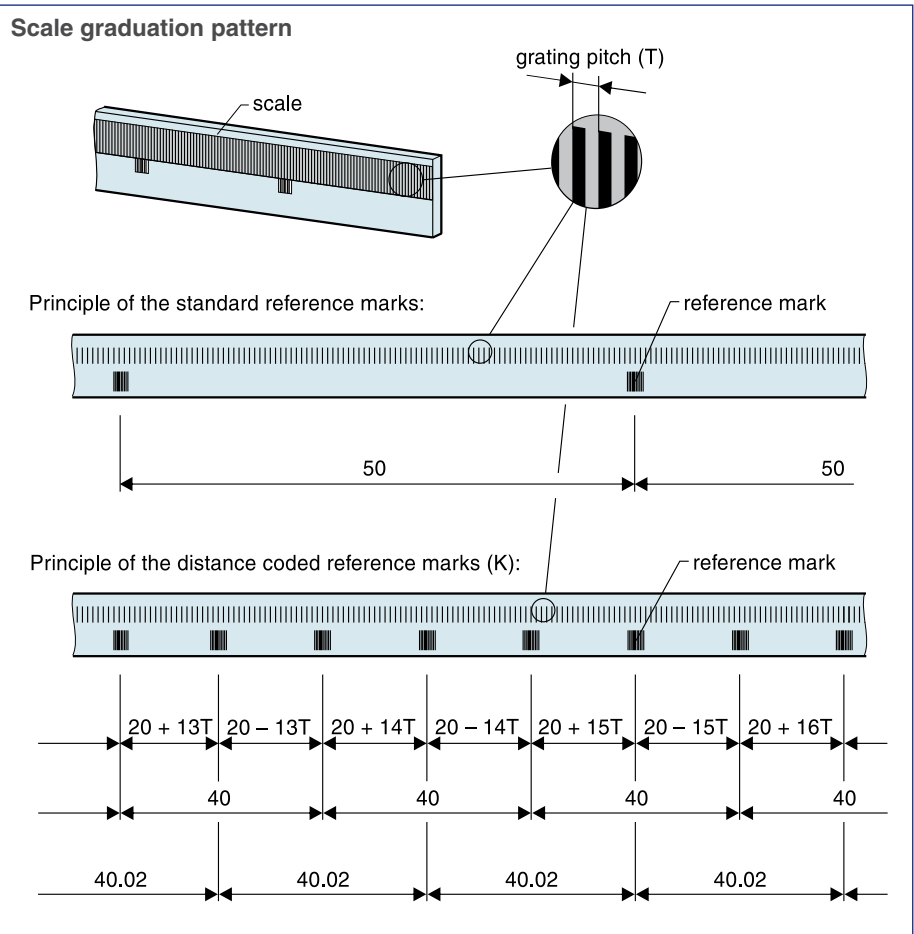

Shielding, Pin Assignments

Shielded PUR-cable, Ø 4.3 mm, Bending radius fixed mounting > 10 mm, continuous flexing > 50 mm
 Torsion > 300.000 cycles, Dragchain > 5.000.000 cycles
 Cables for use in vacuum applications are available on request.

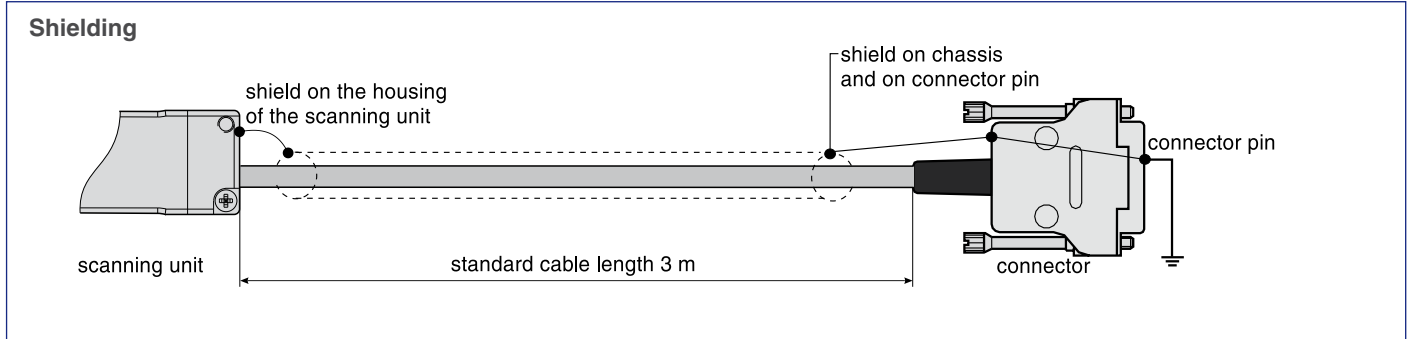

Connector LD15 15-pin

Pin	1	2	3	4	5	6	7	8	9	10	11	12	13	14	15
Sinusoidal voltage signals 1 Vpp	nc	0 V sensor	nc	\overline{RI}	$\overline{A2}$	$\overline{A1}$	+5 V sensor	+5 V	0 V	S1**	S2**	RI	A2	A1	shield
Square-wave signals via Line Driver	test*	0 V sensor	\overline{US}	\overline{RI}	$\overline{T2}$	$\overline{T1}$	+5 V sensor	+5 V	0 V	S1**	S2**	RI	T2	T1	shield

- * Test: **analog signal switch-over for setup**
 By applying +5 V to the test-pin, the test signals (sinusoidal micro-current signals 11 µApp) are switched to the output connector.

- **MS 30:** S1, S2 = switch signals

- **MS 31:** S1 = conditionally useable as switch signal, S2 = switch signal

- ** Version without switch signals (version 0) = nc

- Sensor: the sensor-pins are switched with the particular power supply.

- The shield is additional connected with the chassis.

PIN assignment
 (view on pins)

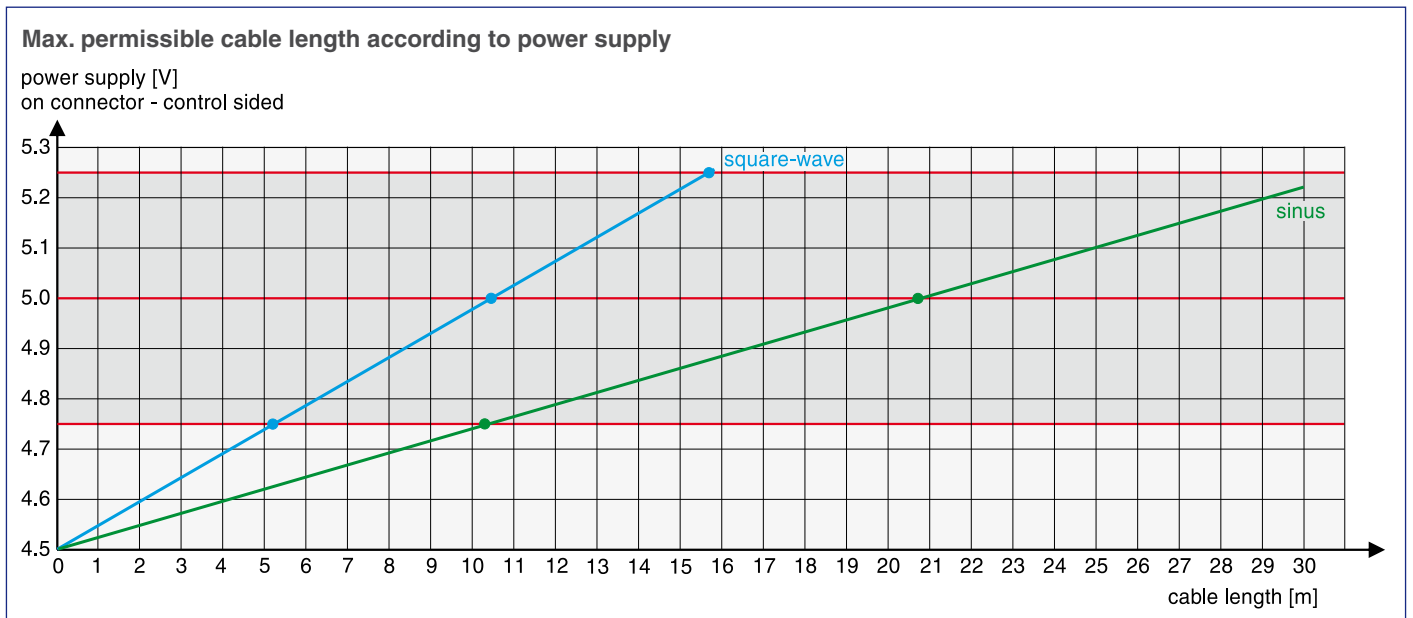

Output Signals

Sinusoidal voltage signals 1Vpp

(drawing shows "positive counting direction")

Two sinusoidal voltage signals A1 and A2 and one reference mark signal (all with inverted signals).

Power supply: +5V ±5%, max. 120 mA (unloaded)

Track signals (differential voltage A1 to $\overline{A1}$ resp. A2 to $\overline{A2}$):

Signal amplitude 0.6 Vpp to 1.2 Vpp; typ. 1 Vpp

(with terminating impedance $Z_0 = 120 \Omega$ between A1 to $\overline{A1}$ resp. A2 to $\overline{A2}$)

Reference mark

(differential voltage RI to \overline{RI}):

Useable component 0.2 up to 0.85 V; typical 0.5 V

(with terminating impedance $Z_0 = 120 \Omega$ between RI to \overline{RI})

Advantage:

- High traversing speed with long cable lengths possible

Square-wave signals

(drawing shows "positive counting direction")

With a Schmitt-Trigger (for times 1) or interpolation electronics

(for times -5, -10, -20, -25, -50 or -100) the photoelement output signals are converted into two square-wave signals that have a phase shift of 90°.

Output signals either can be "single ended" or Line Driver "differential" (RS 422).

One measuring step reflects the measuring distance between two edges of the square-wave signals.

The controls/DRO's must be able to detect each edge of the square-wave signals.

The minimum edge separation a_{min} is listed in the technical data and refers to a measurement at the output of the interpolator (inside the scanning head).

Propagation-time differences in the Line Driver, the cable and the Line Receiver reduce the edge separation.

Propagation-time differences:

Line Driver: max. 10 ns

Cable: 0.2 ns per meter

Line receiver: max. 10 ns referred to the recommended Line Receiver circuit

To prevent counting errors, the controls/DRO's must be able to process the resulting edge separation.

Example:

$a_{min} = 100 \text{ ns}$, 10 m cable

$100 \text{ ns} - 10 \text{ ns} - 10 \times 0.2 \text{ ns} - 10 \text{ ns} = 78 \text{ ns}$

Power supply: +5V ±5%, max. 200 mA (unloaded)

Advantage:

- Noise immune signals

- No further subdividing electronics necessary

Voltage signals (1 Vpp)

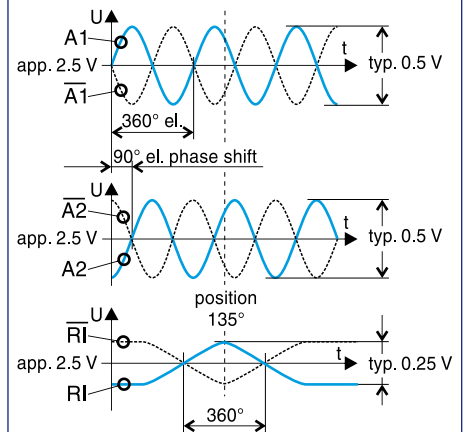

Square wave signals „differential“

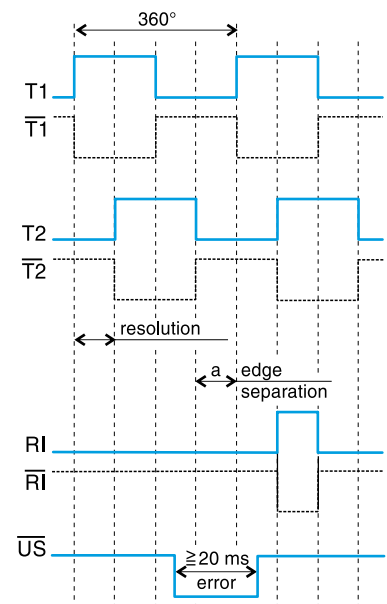

Recommended Line Receiver circuit

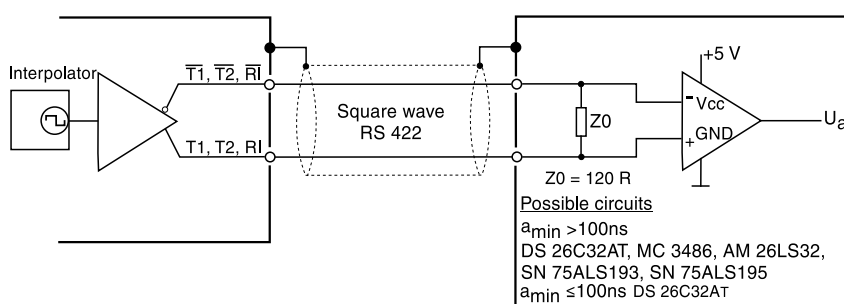

Counting direction

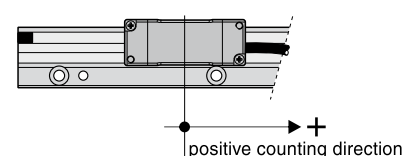

Switch Signal Output

For individual special functions there are two additional switch tracks on the glass / glass ceramic or steel tape scale. The switching point position can be chosen by the user by placing self-adhesive covering tapes.

With the MS 31.xx version there is just one switch signal available. The second track of this version is used to select the reference mark. This feature makes the selection of the reference mark position, by the user, very easy.

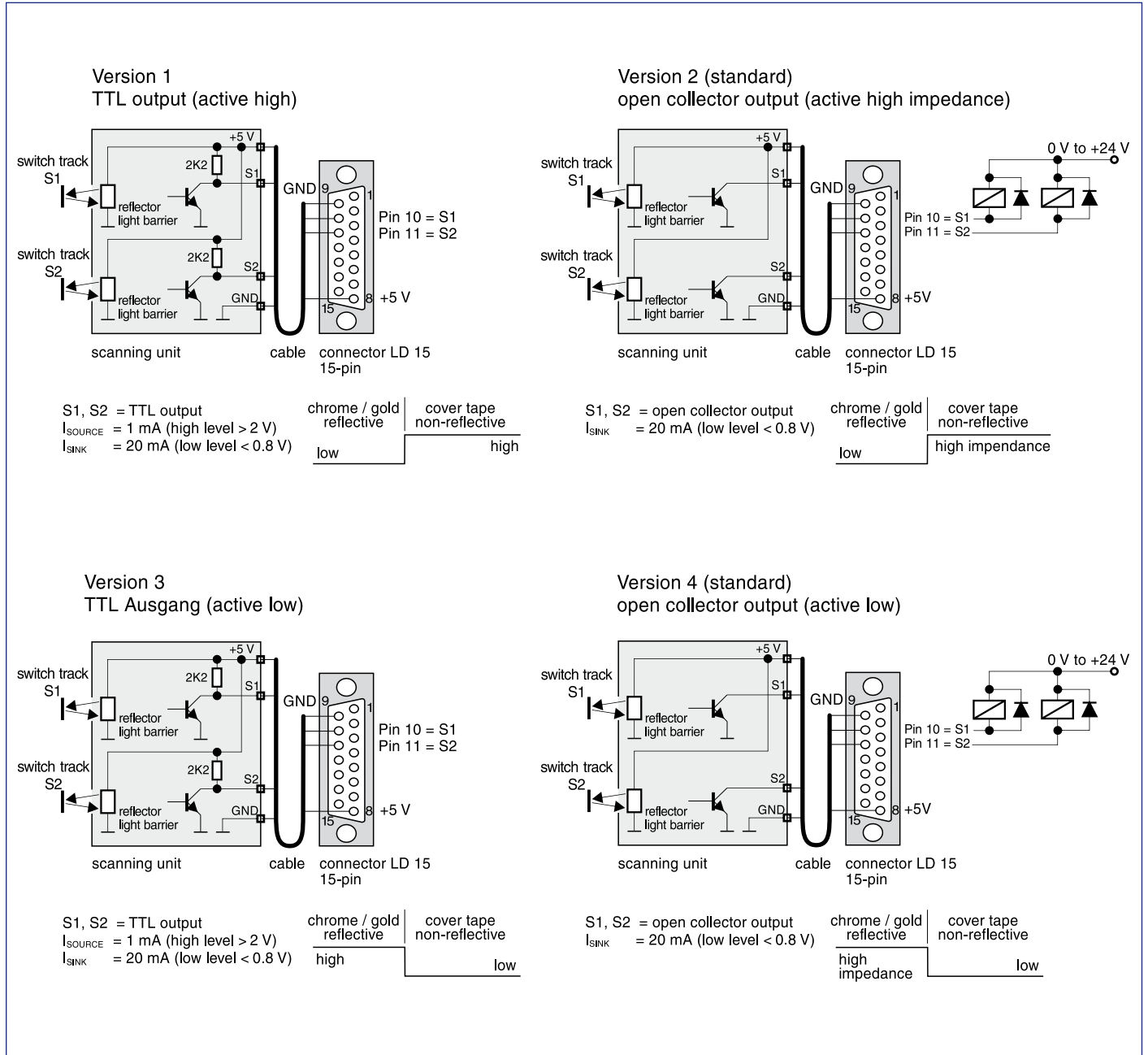









Features

- Small dimensions
- Easy mounting as a result of large mounting tolerances
- High insensitivity to contamination by use of an extensive singlefield scanning principle
- High traversing speed
- Integrated subdividing electronics: for up to times 100 (before quadrature)
- Reference mark accurate and repeatable from both traversing directions
- Grating pitch 20 μm

MS 30: Two independent switch signals (optical) for individual functions

MS 31: Position of reference mark can be selected by the customer
One switch signal (optical) for individual functions

Scale model	Output signals	System resolution [μm]	Integrated interpolation	Maximum velocity [m/s]	Max. output frequency [kHz]
MS 3x.03	 1 Vpp	depending on external interpolation	--	7.0	350
					Edge separation a_{\min}
MS 3x.23		5	times 1	4.0	800 ns
MS 3x.63		1	times 5	3.2	300 ns
MS 3x.73		0.5	times 10	1.6	300 ns
MS 3x.43		0.25	times 20	1.2	200 ns
MS 3x.53		0.2	times 25	0.96	200 ns
MS 3x.83		0.1	times 50	0.96	100 ns
MS 3x.93		0.05	times 100	0.48	100 ns

Technical Data

Mechanical features of the grating carrier	MS 30 Grating carrier		MS 31 Grating carrier	
	Glass	Steel	Glass	Steel
Grating pitch	20 µm	20 µm	20 µm	20 µm
Accuracy grades	±3, ±5 µm/m	±5, ±15 µm/m	±3, ±5 µm/m	±5, ±15 µm/m
Non-linearity	<±1 µm/70 mm <±3 µm/1000 mm		<±1 µm/70 mm <±3 µm/1000 mm	
Maximum measuring length (ML)	3140 mm	11940 mm	3140 mm	11940 mm
Reference marks (RI) standard: separated by n x 50 mm	■	■	■	■
Reference marks (RI) at any location, on request	--	■	■	■
Reference marks (RI) distance-coded	■ to ML 3140 mm	■ to ML 6240 mm	--	--
Reference marks-position selected by customer	--	--	■	■
Switch tracks	2	2	1	1
■ available -- not available				

Mounting-adjustment/Test:

To optimize or check the mounting we recommend to use a compatible electronic signal test/set-up box PG1 or PG3 (page 18).

Permissible vibration: 150 m/s² (40 up to 2000 Hz)

Permissible shock: 750 m/s² (8 ms)

Permissible temperature:

-20 °C up to +70 °C (storage), 0 °C up to +50 °C (operation)

MS 3x.xx MO, MK

- Version MO: Steel tape scale
- Version MK: Steel tape scale with adhesive tape



Dimensions, mounting tolerances:

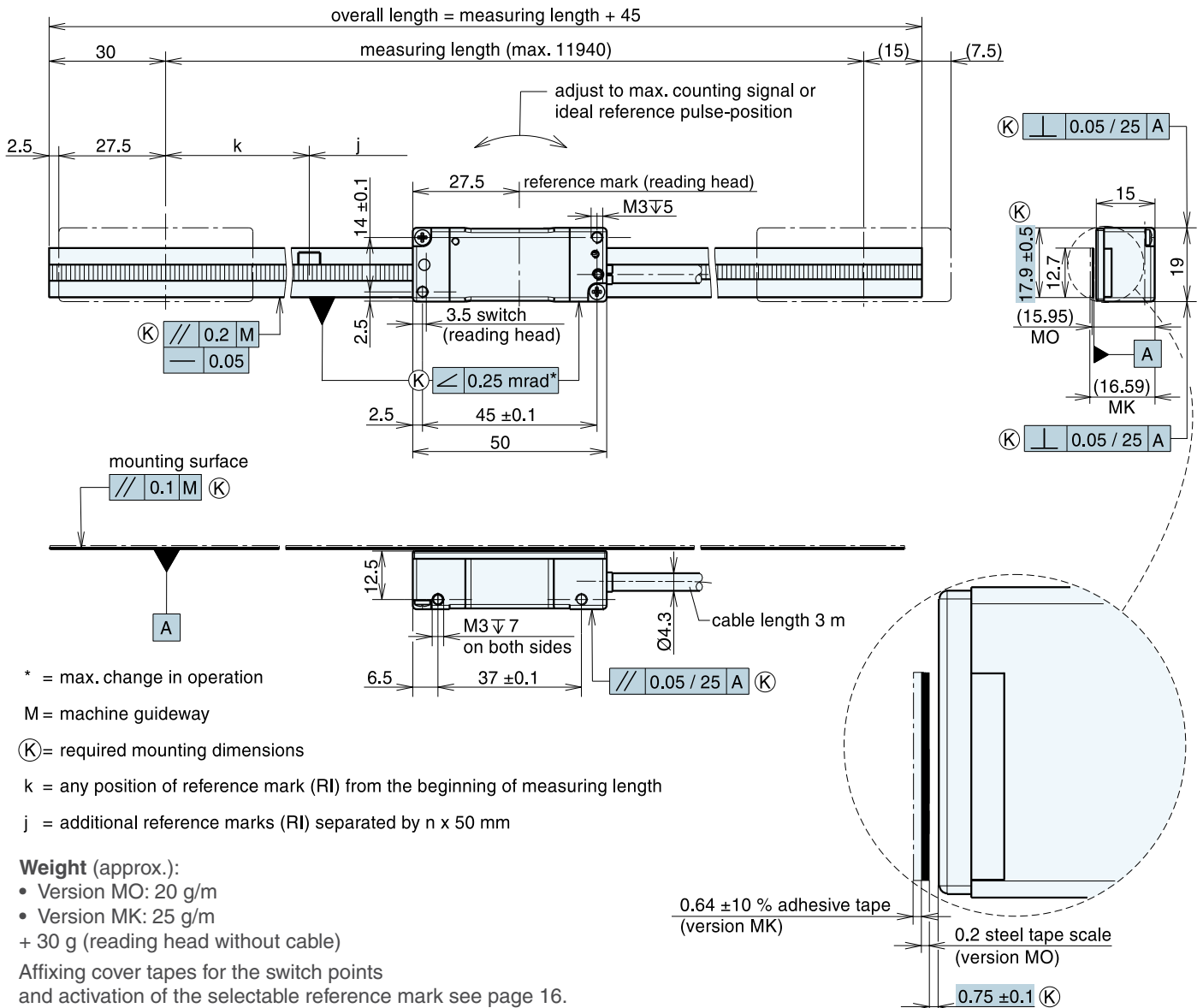

Tape mounting tool **TMT 30 MK** (optional)
For safe and precise mounting of the steel tape scale.

- Mount TMT 30 MK instead of the reading head MS 3x
- Thread steel tape scale (version MK) and move along the scale length
- Remove TMT 30 MK, mount reading head MS 3x

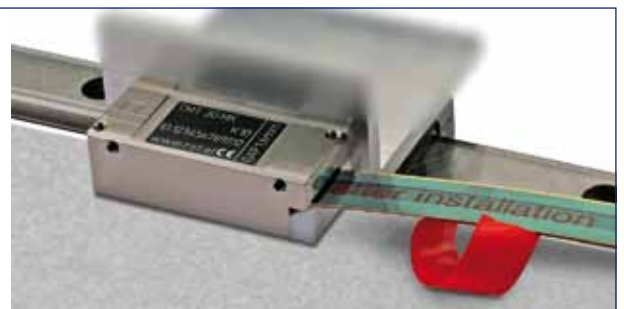

MS 3x.xx MA, MS

- Version MA: Steel tape scale on aluminum carrier
- Version MS: Steel tape scale on steel carrier
- Version MA, MS: Carrier bolted



Dimensions, mounting tolerances:

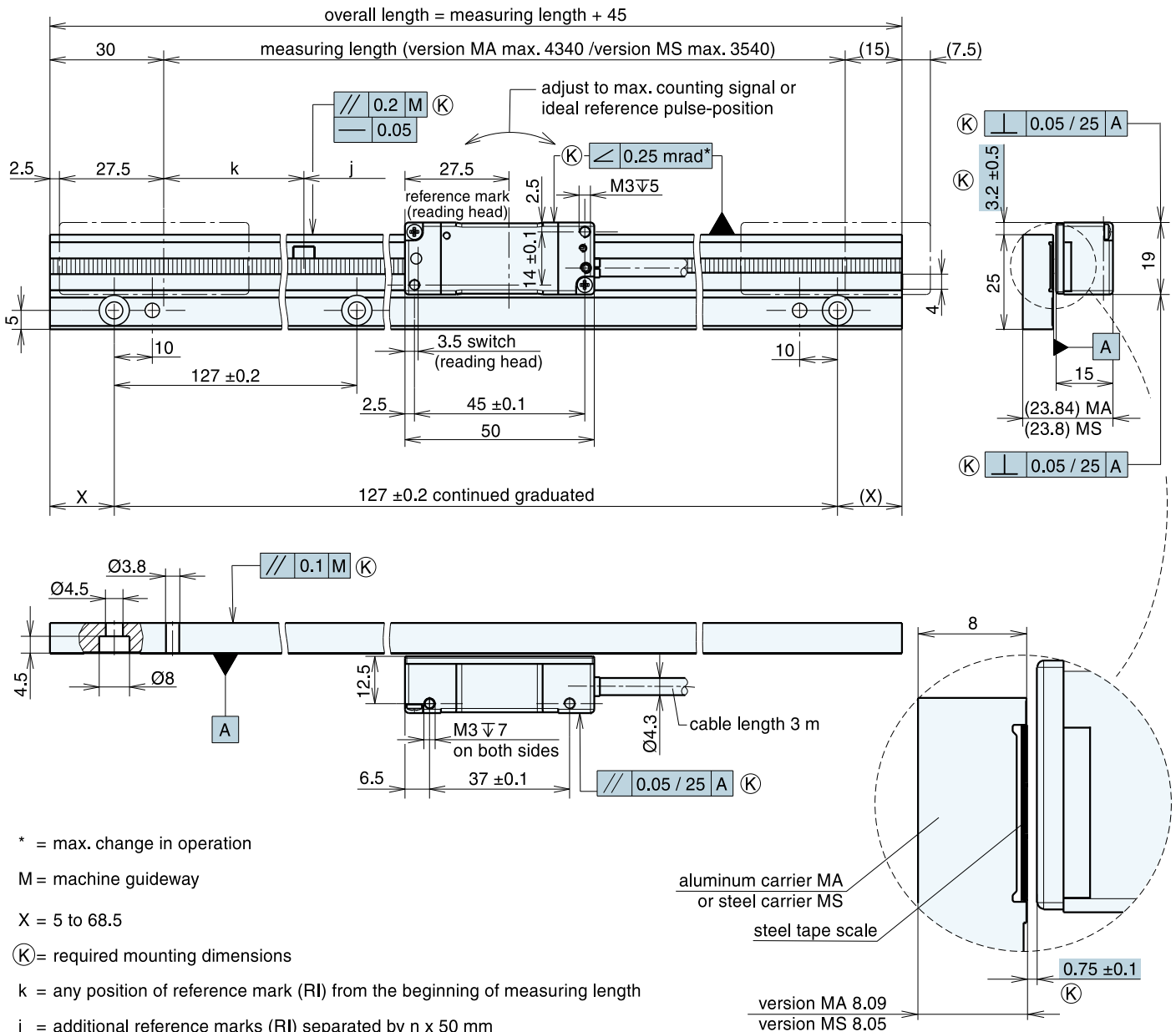

* = max. change in operation

M = machine guideway

X = 5 to 68.5

(K) = required mounting dimensions

k = any position of reference mark (RI) from the beginning of measuring length

j = additional reference marks (RI) separated by n x 50 mm

Weight (approx.):

- Version MA: 530 g/m
- Version MS: 1 525 g/m
- + 30 g (reading head without cable)

Affixing cover tapes for the switch points and activation of the selectable reference mark see page 16.

MS 3x.xx MP

- Steel tape scale in aluminum carrier with clamping element
- Carrier with adhesive tape



Dimensions, mounting tolerances:

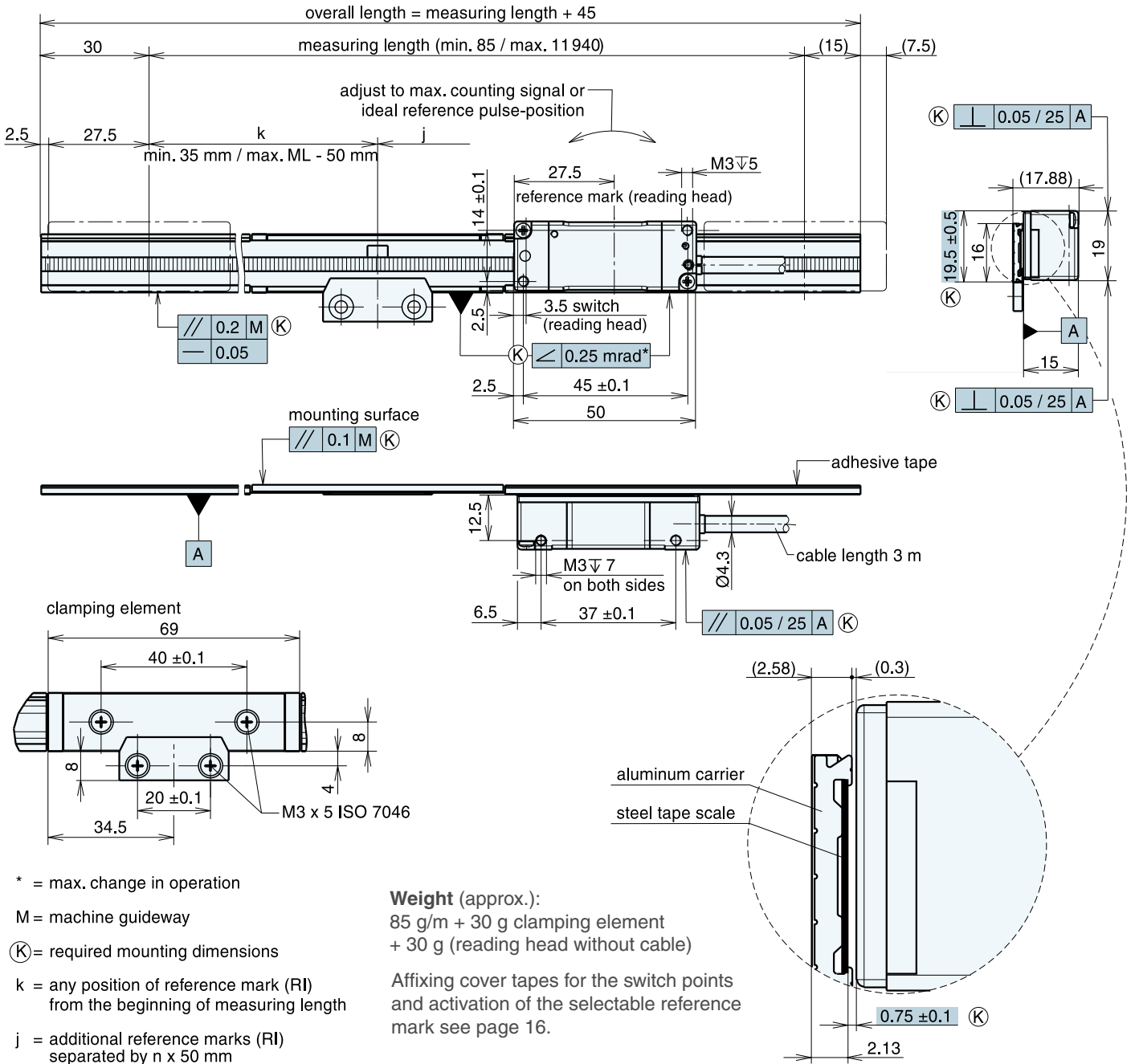

* = max. change in operation

M = machine guideway

(K) = required mounting dimensions

k = any position of reference mark (RI) from the beginning of measuring length

j = additional reference marks (RI) separated by n x 50 mm

Weight (approx.):
85 g/m + 30 g clamping element
+ 30 g (reading head without cable)

Affixing cover tapes for the switch points and activation of the selectable reference mark see page 16.

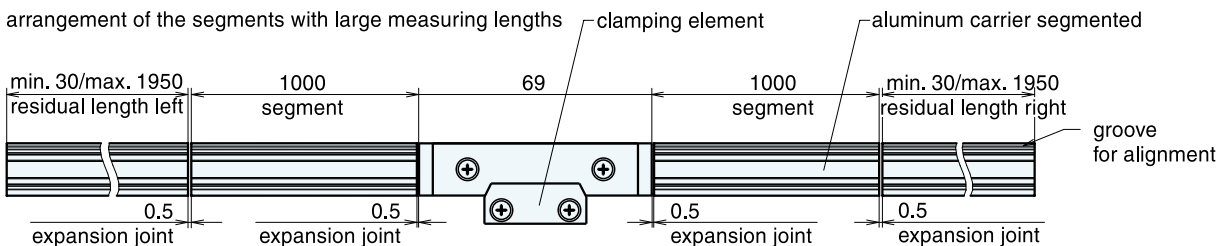

MS 3x.xx MT

- Steel tape scale in aluminum carrier with clamping element
- Carrier bolted



Dimension, mounting tolerances:

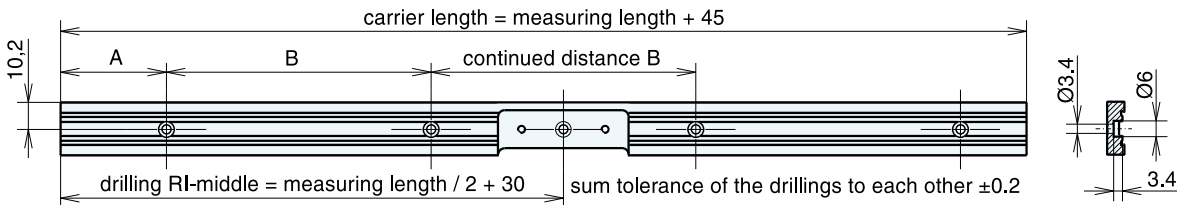
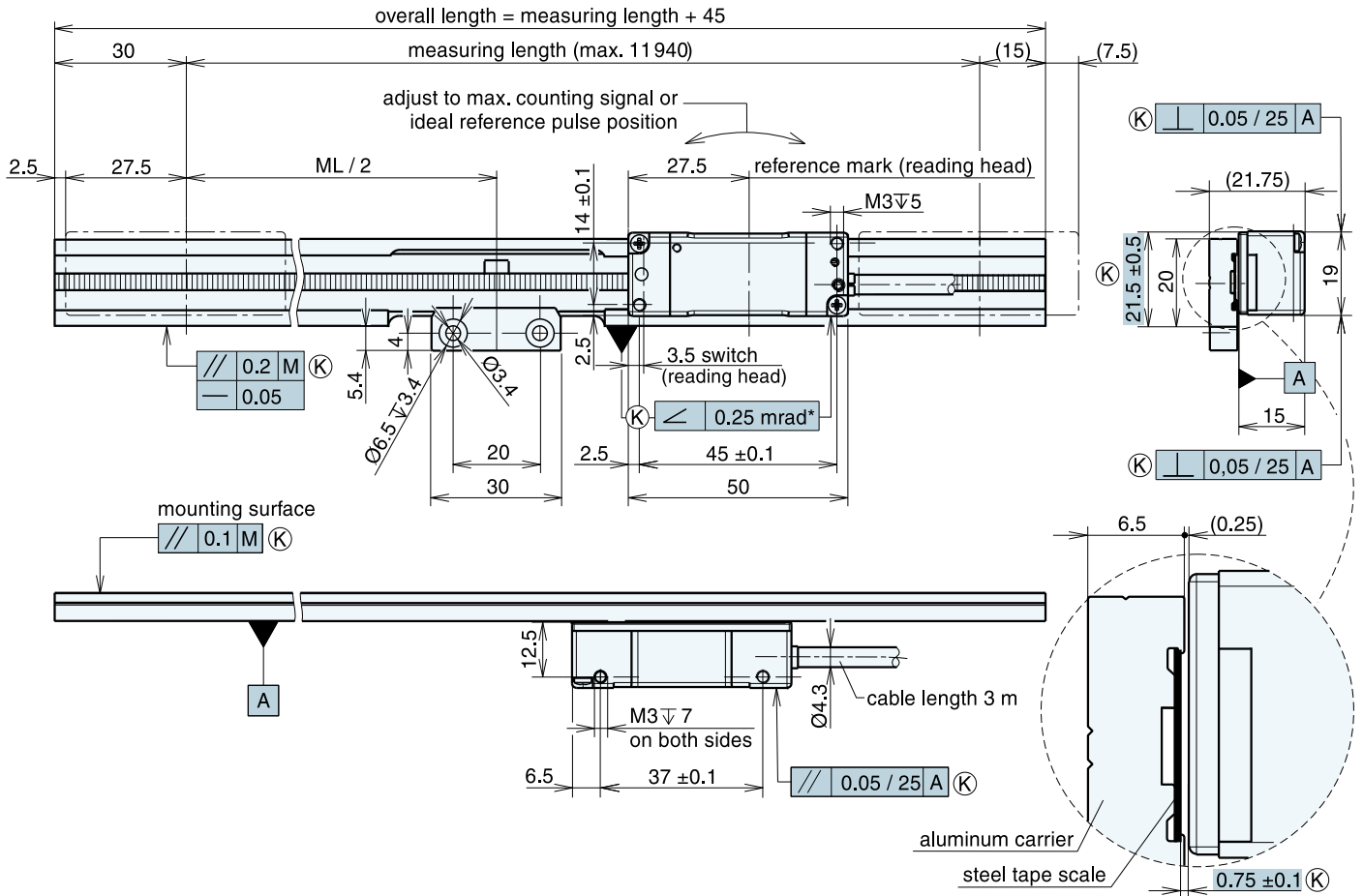

Measuring length (ML)	A	B
120	40	50
170	40	75
from ML 220	A	B
x20 e.g. 320	40	100
x70 e.g. 770	65	100
xxx40 e.g. 11040	50	100

* = max. change in operation

M = machine guideway

(K) = required mounting dimensions

Weight (approx.):
325 g/m + 30 g clamping element
+ 30 g (reading head without cable)

Affixing cover tapes for the switch points
and activation of the selectable reference mark see page 16.

MS 3x.xx GK

- Glass scale with adhesive tape
- Standard: Sinusoidal output signals



Dimensions, mounting tolerances:

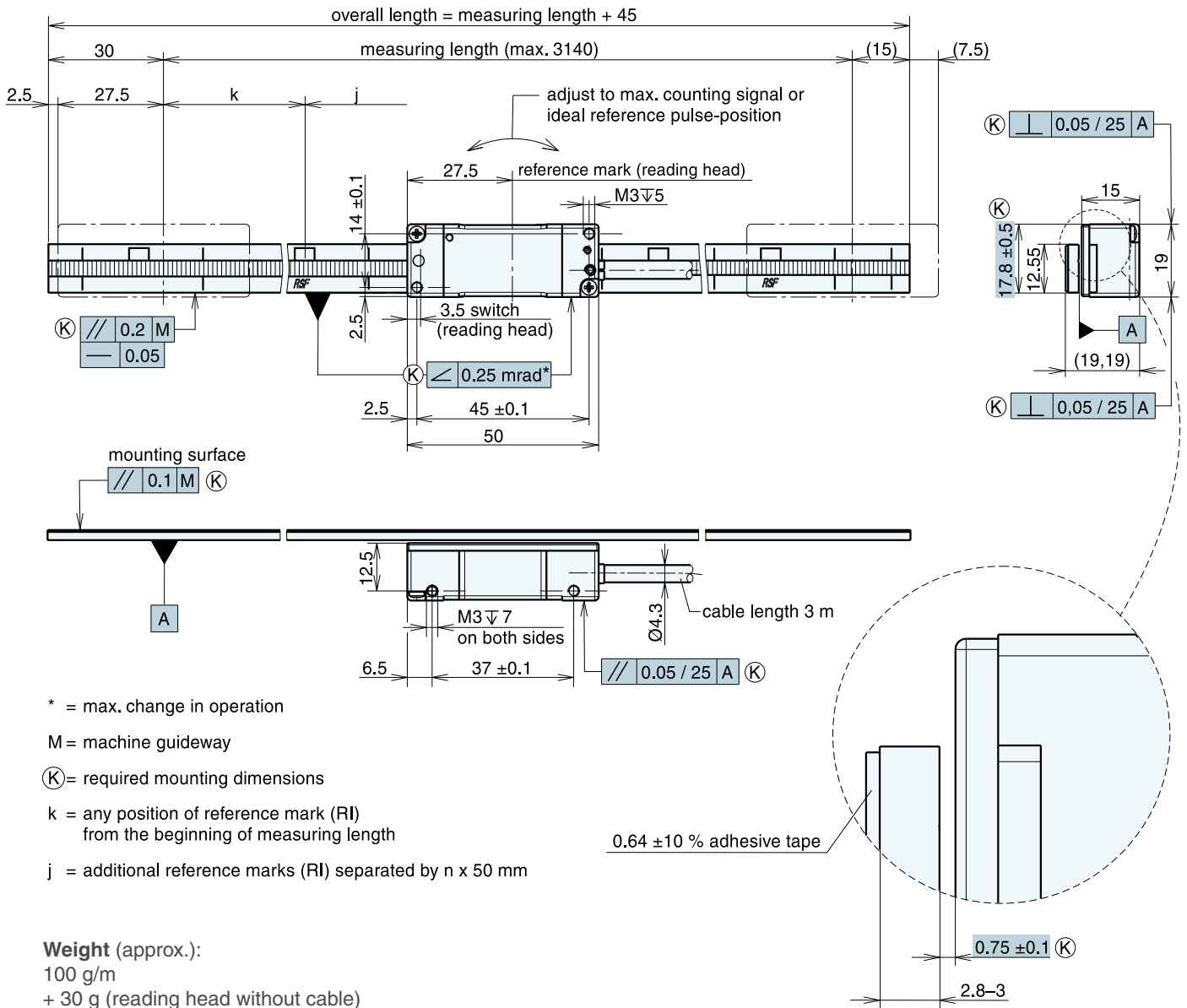

* = max. change in operation

M = machine guideway

(K) = required mounting dimensions

k = any position of reference mark (RI) from the beginning of measuring length

j = additional reference marks (RI) separated by n x 50 mm

Weight (approx.):

100 g/m

+ 30 g (reading head without cable)

Affixing cover tapes for the switch points and activation of the selectable reference mark see page 16

MS 3x.xx GA

- Glass scale in aluminum carrier
- Carrier bolted
- Standard: Sinusoidal output signals



Dimensions, mounting tolerances:

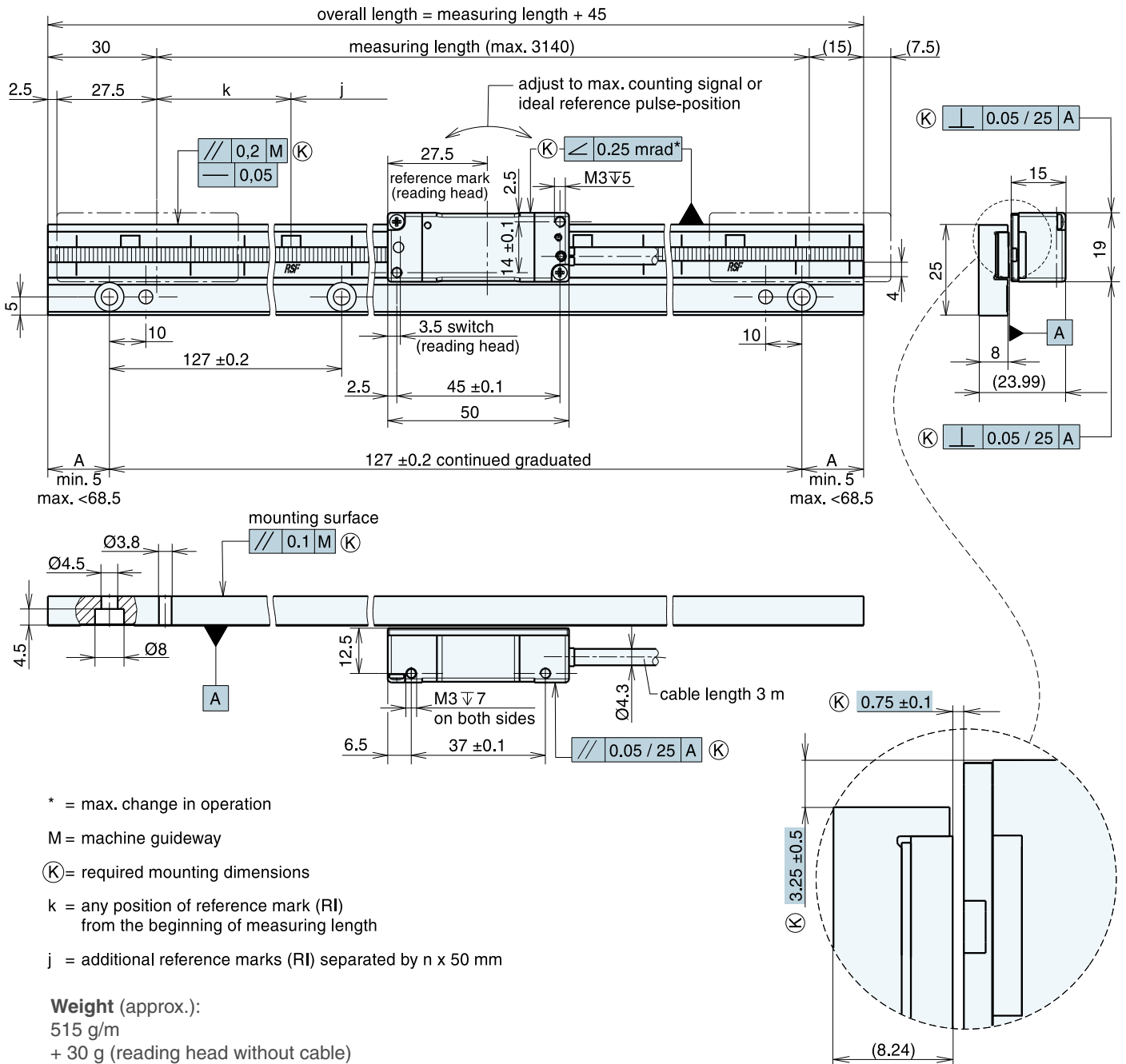

* = max. change in operation

M = machine guideway

(K) = required mounting dimensions

k = any position of reference mark (RI) from the beginning of measuring length

j = additional reference marks (RI) separated by n x 50 mm

Weight (approx.):

515 g/m

+ 30 g (reading head without cable)

Affixing cover tapes for the switch points

and activation of the selectable reference mark see page 16

Switch Points, Reference Mark (RI)-select

MS 30: Positioning of the switch points

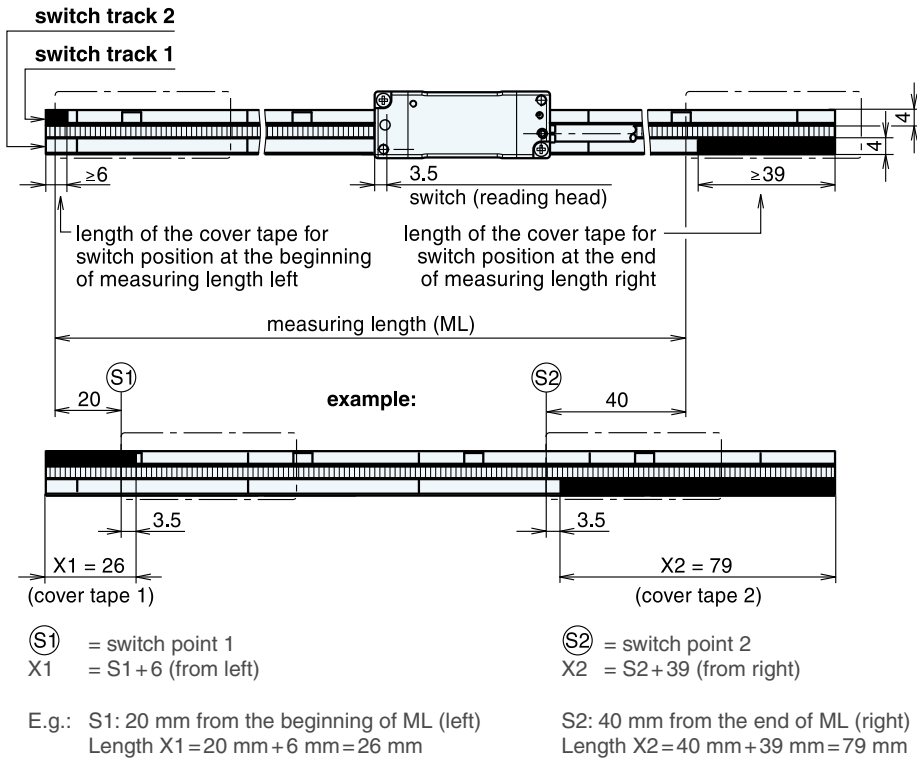

MS 31: Reference mark (RI)-select, positioning of the switch points

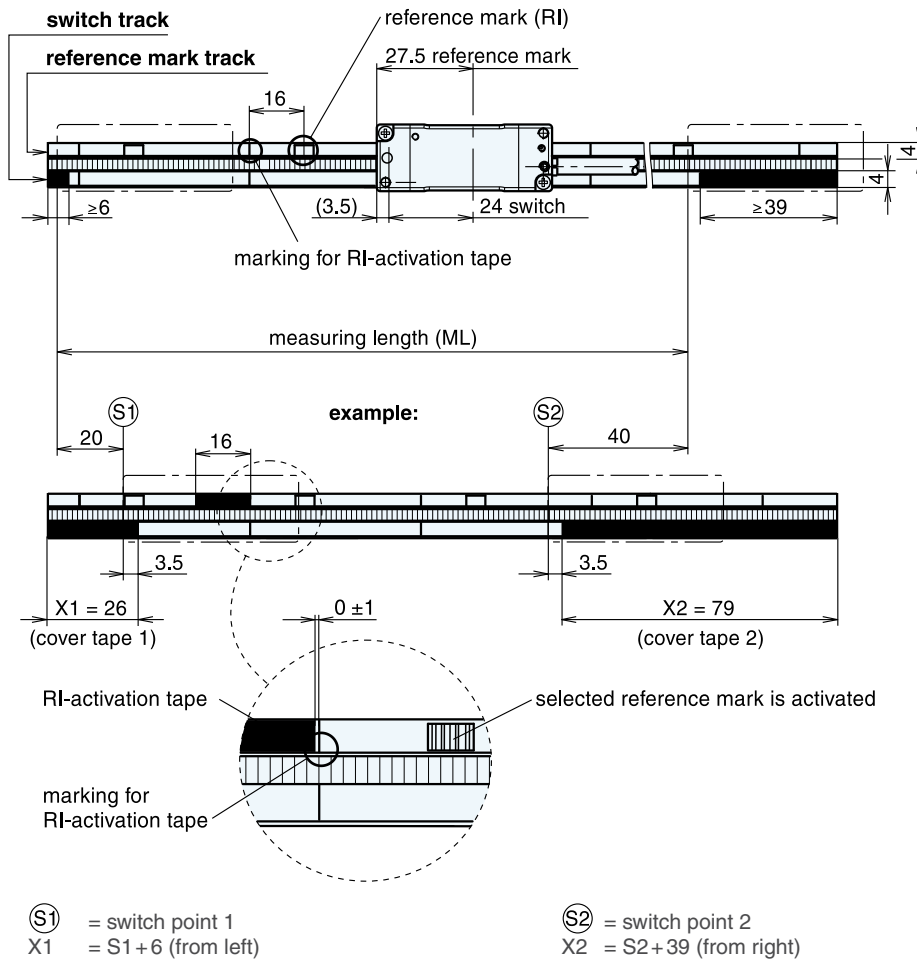

Accuracy

The accuracy of the Linear Encoder is classified with a "± tolerance" in µm/m (e.g. ± 5 µm/m).

The accuracy refers to any meter within the measuring length.
For measuring lengths less than 1000 mm, the accuracy specification applies to the whole measuring length.

For best system accuracy, the encoder should be mounted near the machining level and as parallel as possible to the motion direction.

Example of a typical calibration chart for a MS3x scale tape:

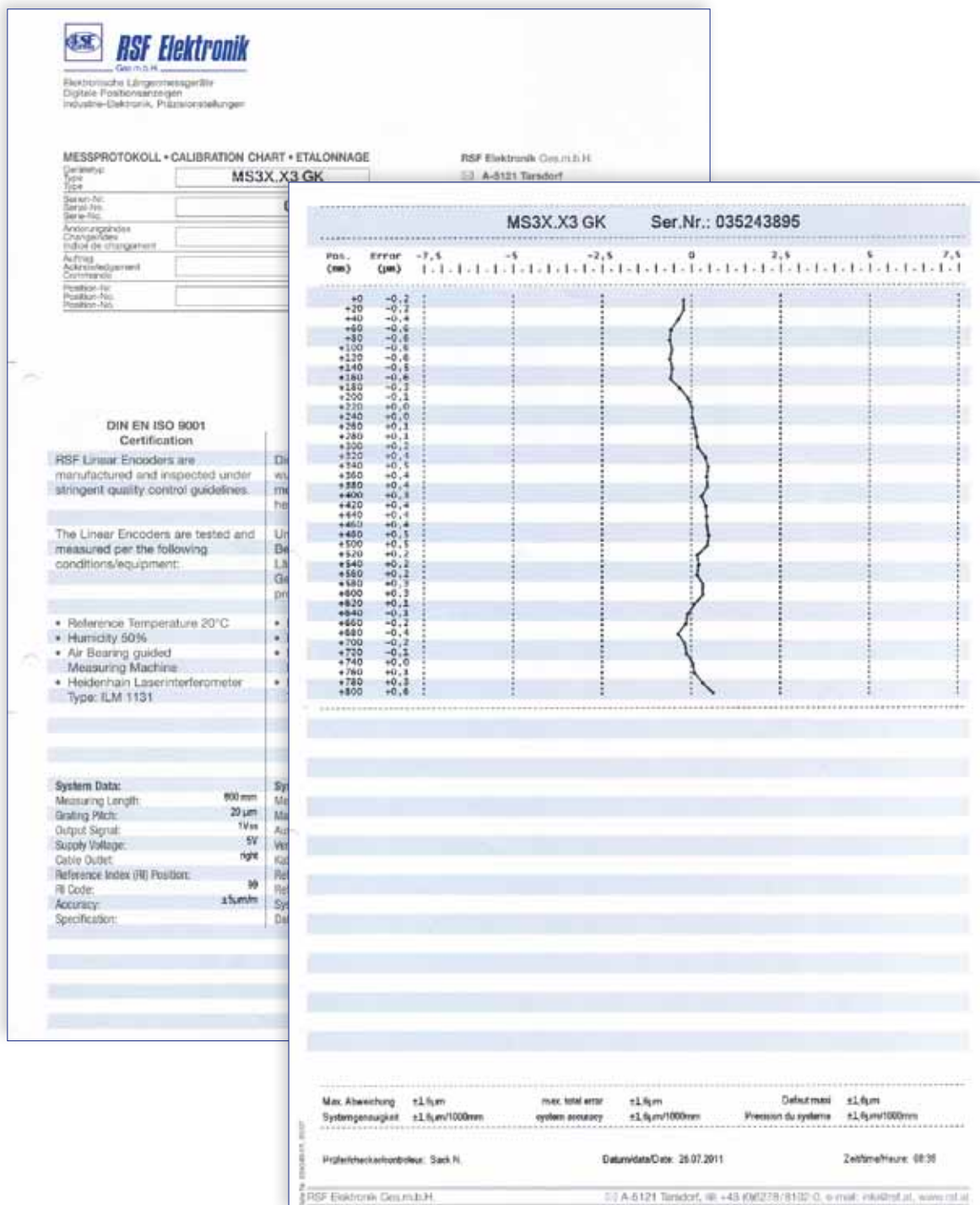

Electronical Signal Test/Set-up Boxes PG

Open Linear Encoders are adjusted at the factory to provide optimal signals at the specified mounting conditions.

Even though the Linear Encoders in the MS 3x series allow for large mechanical mounting tolerances, it is recommended to inspect the mounting by checking the quality of the output signals.

There are various methods of checking the quality of the output signals. The signals can be connected to an oscilloscope and checked for conformity with signal specifications. This method requires effort, training and expensive test equipment (oscilloscope). Often one or all of these items are unavailable to the installing technician. As an alternative to this method, RSF offers different signal test boxes. With these test boxes all encoder signals can be quickly and easily checked.

The **PG1-I / PG1-U** is an all-purpose signal test box where all the relevant signals are displayed on LCD Bars, and allows the quantitative as well as the qualitative evaluation of the encoder signals.

The **PG3-I / PG-U** test box checks all relevant signals; amplitude, phase and offset, and displays the results in a qualitative format on a polychromatic LED display.

PG1-I / PG1-U



PG3-I / PG-U

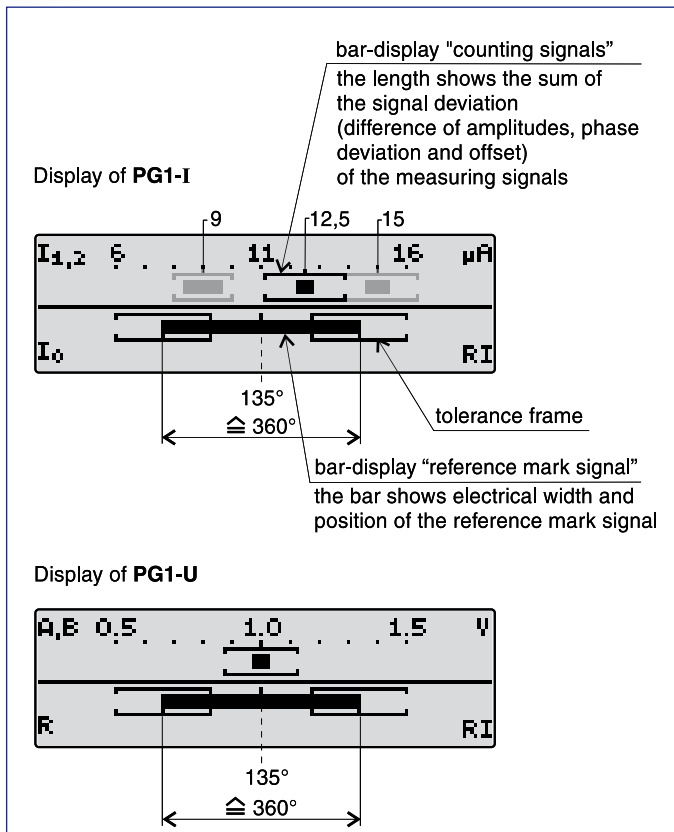

Intended PG use	Output signals	
	Square-wave	Sinus (1 Vpp)
PG1-I	■	--
PG1-U	--	■
PG3-I	■	--
PG-U	--	■

■ intended
-- not intended

Product Directory



MS 2x Series

Reflective scanning Linear Encoder with integrated mounting control (only MS 25, MS 26)

- Easy mounting; no test box or oscilloscope needed
- Quality of the scanning signals is directly visible at the reading head via a 3-colored LED
- Two independent switch signals for individual special functions
- Position of reference mark selectable
- High insensitivity against contamination
- High traversing speed
- integrated subdividing: up to times 100 interpolation
- Max. measuring length: Glass scale: 3140 mm Steel tape scale: 20000 mm



MS 40

Reflective scanning Linear Encoder with low price and high quality

- Small dimensions
- Easy mounting as a result of large mounting tolerances
- High insensitivity against contamination
- High traversing speed
- Integrated subdividing: up to times 100 interpolation
- Max. measuring length: 30000 mm



MS 82

Interferential Linear Encoder

- Two switch tracks for individual special functions
- Non-contact reflective scanning
- High traversing speed
- Small dimensions
- Scale unit: glass scale or ROBAX® -glass ceramic scale with phase grating
- Max. measuring length: Glass scale: 3140 mm Glass ceramic: 1540 mm



MSR 40

Modular Rotary Encoder with steel tape scale

- Different versions
- Full-circle or segment version
 - Grating pitch: 200 µm
 - Accuracy of the grating (stretched): ±30 µm/m
 - High rotational speed resp. circumferential speed
 - Integrated subdividing: up to times 100 interpolation

MSR 20

- Segment version
- Grating pitch: 40 µm
- Accuracy of the grating (stretched): ±15 µm/m
- High circumferential speed
- Integrated subdividing: up to times 100 interpolation



MSA 170

- Enclosed version
- Guided by ball bearings
- Distance coded reference marks
- Mounting holes on the extrusion ends
- Max. measuring length: 520 mm



MSA 374

- With integrated guide rail system
- For application on presses bending machines and hydraulic cylinders
- Enclosed version
- Roller bearing dual guided scanning carriage
- Free positionable switching magnets for special functions
- Distance coded reference marks
- Mounting holes on the extrusion ends
- Max. measuring length: 720 mm



MSA 7xx, MSA 8xx series

(small dimensions)

MSA 4xx, MSA 5xx series

(large dimensions)

- Optimized thermal behavior
- Connection cable pluggable (optional)
- Enclosed version
- Distance coded reference marks
- Mounting holes at the ends or along the scale unit for improved vibration stability
- Max. measuring length: 3040 mm



Cable Systems

- Individual cable design
- Hybrid cable
- Trailing cable
- System solutions
- Function control

DISTRIBUTION CONTACTS

Austria Corporate Head Quarters

RSF Elektronik Ges.m.b.H.
A-5121 Tarsdorf
☎ +43 (0) 62 78 81 92-0
FAX +43 (0) 62 78 81 92-79
e-mail: info@rsf.at
internet: www.rsf.at

Italy

HEIDENHAIN ITALIANA S.r.l.
Via Asiago, 14
20128 Milano (MI)
☎ +39 0227075-1
FAX +39 0227075-210
e-mail: info@heidenhain.it

Switzerland

RSF Elektronik (Schweiz) AG
Vieristrasse 14
CH-8603 Schwerzenbach
☎ +41 (0) 44 955 1050
FAX +41 (0) 44 955 1051
e-mail: info@rsf.ch
internet: www.rsf.ch

Slovenia

RSF Elektronik prodaja, d.o.o.
Jozeta Jame 14
SI-1210 Ljubljana
☎ +386 (0) 1 519 88 80
FAX +386 (0) 1 519 88 80
e-mail: mail@rsf-elektronik.si

United Kingdom

HEIDENHAIN (GB) Ltd.
200 London Road
Burgess Hill
West Sussex RH15 9RD
☎ +44 (0)1444 238550
FAX +44 (0)1444 870024
e-mail: sales@heidenhain.co.uk

USA

HEIDENHAIN CORPORATION
333 East State Parkway
Schaumburg, IL 60173-5337
☎ +1 847 490 11 91
e-mail: info@heidenhain.com
internet: www.rsf.net

China

RSF Elektronik GmbH
Tian Wei San Jie,
Area A, Beijing Tianzhu Airport Industrial Zone
Shunyi District
101312 Beijing
P.R. China
☎ +86 (0) 10 80 42 02 88
FAX +86 (0) 10 80 42 02 90
e-mail: cao.shizhi@rsf.cn
internet: www.rsf.cn

Korea

HEIDENHAIN LTD.
201 Namsung Plaza, 9th Ace Techno Tower,
345-30, Gasan-Dong, Geumcheon-Gu,
Seoul, Korea 153-782
☎ +82 (0) 2 20 28 74 30
e-mail: info@heidenhain.co.kr
internet: www.rsf.co.kr



Date 04/2012 ■ Art.No. 510205-27 ■ Doc.Nr. D510205-00-A-26 ■ Technical adjustments in reserve!



RSF Elektronik
Ges.m.b.H.

Linear Encoders
Digital Readouts
Precision Graduations
Cable Systems

Certified acc. to
DIN EN ISO 9001
DIN EN ISO 14001

✉ **A-5121 Tarsdorf** ■ ☎ +43 (0)6278 / 8192-0 ■ FAX +43 (0)6278 / 8192-79 ■ e-mail: info@rsf.at ■ internet: www.rsf.at