



# MODEL EK2

## BACKLASH FREE ELASTOMER COUPLINGS



Standard version with clamping hubs

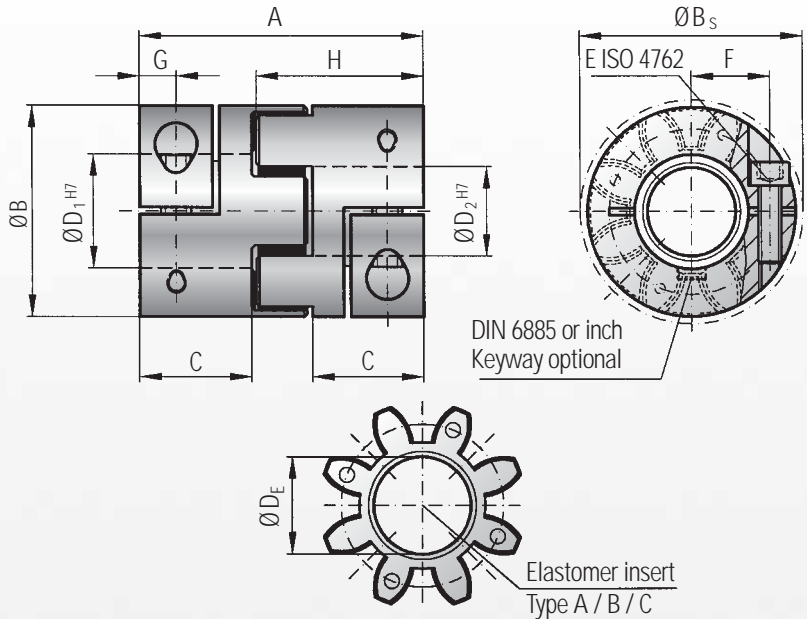

### Properties:

- easy assembly
- concentrically machined hubs
- vibration damping
- electrically isolating
- backlash free
- press fit design

### Material:

Clamping hub: up to series 450 high strength aluminum, from series 800 and up steel  
 Elastomer insert: precision molded, wear resistant, and thermally stable polymer

### Design:

Two coupling hubs are concentrically machined with curved jaws

### Speeds:

See table below

\*Please contact R+W

ISO 2.5 balance grade available

### Tolerance:

Overall clearance between shaft and hub 0.01 to 0.05 mm

Model EK 2	Series																	
	20			60			150			300			450			800		
Type (Elastomer insert)	A	B	C	A	B	C	A	B	C	A	B	C	A	B	C	A	B	C
Rated torque (Nm)	17	21	6	60	75	20	160	200	42	325	405	84	530	660	95	950	1100	240
Max. torque** (Nm)	34	42	12	120	150	35	320	400	85	650	810	170	1060	1350	190	1900	2150	400
Overall length (mm)	66			78			90			114			126			162		
Outside diameter (mm)	42			56			66.5			82			102			136.5		
Outside diameter with screw head (mm)	44.5			57			68			85			105			139		
Mounting length (mm)	25			30			35			45			50			65		
Inside diameter range H7 (mm)	8 - 25			12 - 32			19 - 36			20 - 45			28 - 60			35 - 80		
Inside diameter of elastomer (mm)	19.2			26.2			29.2			36.2			46.2			60.5		
Clamping screw (ISO 4762)	M5			M6			M8			M10			M12			M16		
Tightening torque of the clamping screw (Nm)	8			15			35			70			120			290		
Distance between centers (mm)	15.5			21			24			29			38			50.5		
Distance (mm)	8.5			10			12			15			17.5			23		
Hub length (mm)	39			46			52.5			66			73			93.5		
Moment of inertia per Hub (10 <sup>-3</sup> kgm <sup>2</sup> )	0.016			0.05			0.13			0.4			0.9			9.5		
Approx. weight (kg)	0.15			0.35			0.6			1.1			1.7			10		
Speed standard (min <sup>-1</sup> )	12,500			11,000			10,000			9,000			8,000			4,000		
*Speed balanced (10 <sup>3</sup> min <sup>-1</sup> )	45	60	35	31	31	25	22	26	18	22	26	16	16	17	12	13	13	8

Information about static and dynamic torsional stiffness as well as max. possible misalignment see page 5

1 Nm = 8.85 in lbs

\*\* Maximum transmittable torque depends on the bore diameter (overall clearance between shaft and hub 0.01 to 0.05 mm; shaft oiled)

Series	Ø 8	Ø 16	Ø 19	Ø 25	Ø 30	Ø 32	Ø 35	Ø 45	Ø 50	Ø 55	Ø 60	Ø 65	Ø 70	Ø 75	Ø 80
20	20	35	45	60											
60		50	80	100	110	120									
150			120	160	180	200	220								
300			200	230	300	350	380	420							
450				420	480	510	600	660	750	850					
800						700	750	800	835	865	900	925	950	1000	

Higher torque through additional key possible.

### Ordering example

EK2 / 60 / A / 19.05 / 24 / XX

Model	_____
Series	_____
Type Elastomer insert	_____
Bore Ø D1 H7	_____
Bore Ø D2 H7	_____
Non standard e.g. finely balanced	_____

All data is subject to change without notice.