

HighForce rack and pinion drives

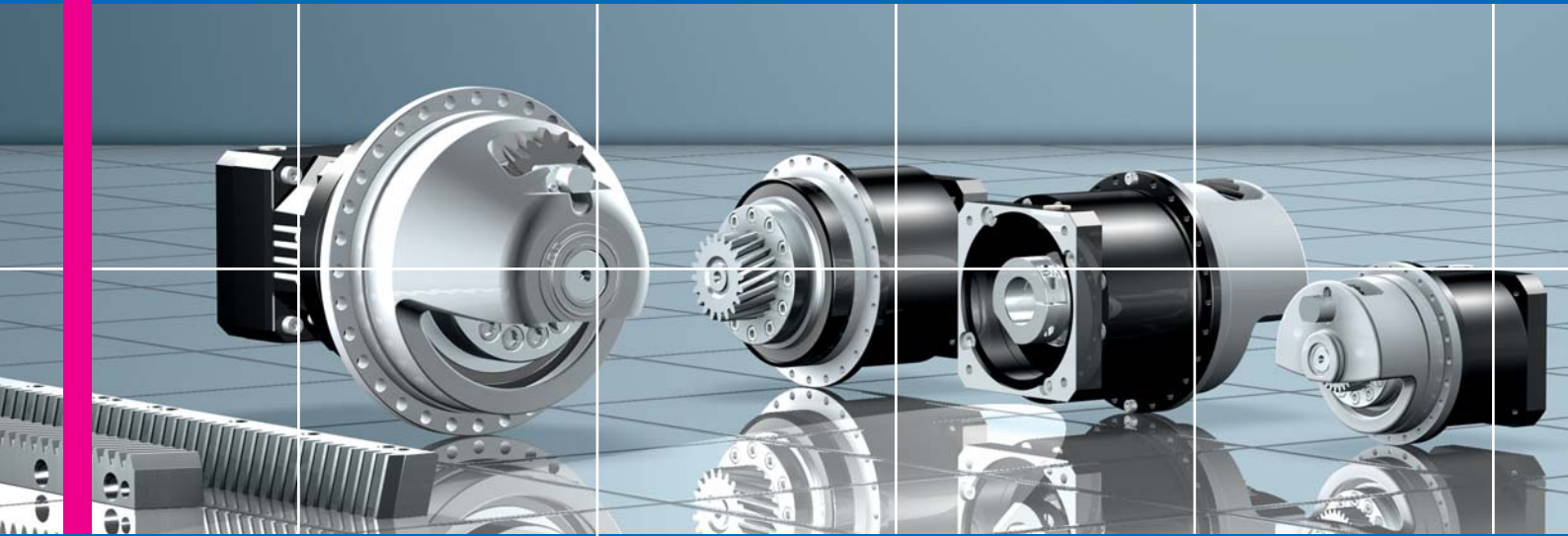

New, high efficiency
rack and pinion drives with
innovative pinion bearing



Drive optimisation for machine tool manufacture

A new compact solution for more efficiency

In the past it was normal on rack and pinion drives to fit the pinion directly to a gear unit's flange shaft.

As a result of this single-sided pinion mounting, the very high tilting moment had to be absorbed by the bearings in the planetary gear unit. With the result that 'over-dimensioned' gear units with an abundant 'excess of torque' were required.

To be able to use smaller gear units with the torque actually required, the highly stiff supporting bearing module with integrated ZTRS pinion was developed.

This practical innovation resulted from the close cooperation of the application experience at STÖBER ANTRIEBSTECHNIK and at the manufacturer of ATLANTA precision gear racks.



The underside of the supporting bearing cover shows the enclosed safety design

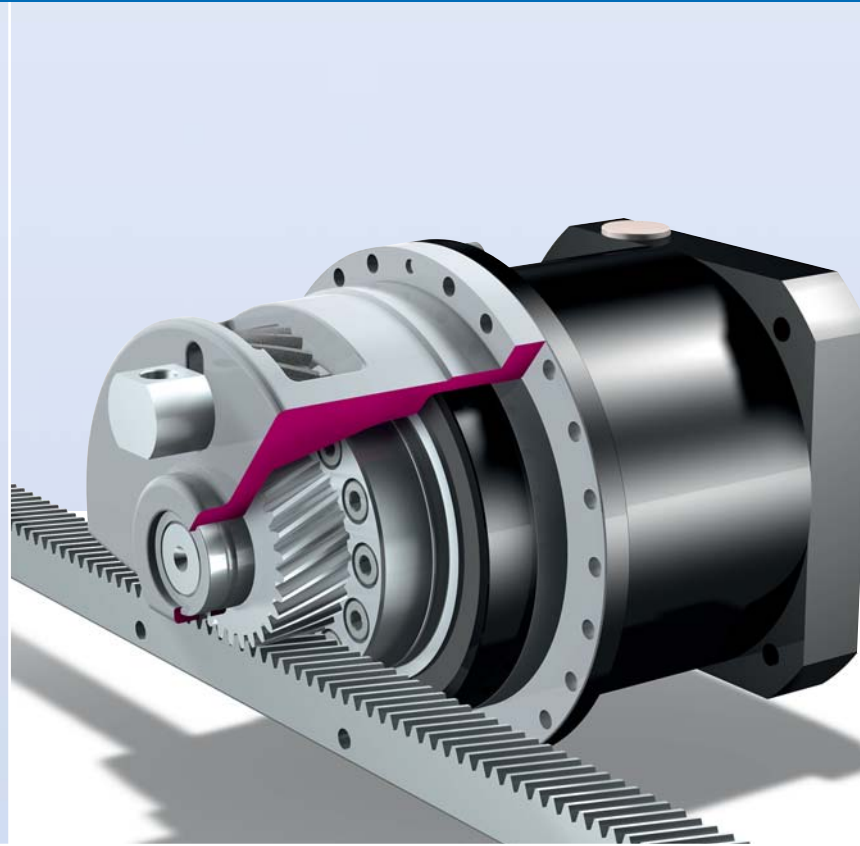

Rack and pinion drive ZTRS-PHA721

Cast supporting bearing cover with ribbed internal contour for highest torsional stiffness

The supporting bearing permits maximum feed forces, minimizes bending and increases the service life

Housing cut-away above with optional felt lubrication pinion for the connection of a central lubrication system or an electronically regulated lubrication cup

Highly stiff rack and pinion drive with supporting bearing

The internal contour of the cast supporting bearing cover is designed with stiffening ribs to provide a highly stiff supporting assembly for the gear rack pinion. Pinion and cover are bolted to the housing and shaft flange of the PH(A) gear unit series.

Due to the additional supporting bearing, very high drive tilting stiffness is achieved. The load is reduced on the bearings in the planetary gear unit.

At the same time the cover serves as a protective housing and is used for mounting the optional lubrication device comprising a felt lubrication pinion running in parallel.

New power densities for high dynamic performance, smaller envelope, less costs

Due to this highly stiff design with reduced tilting moment, the tilting moment is no longer the key parameter on defining the drive (motor and gear unit) as in the past. The crucial criterion for defining the rack and pinion drive can now be orientated on the torque or the feed force actually required.

Because of these design enhancements a smaller gear unit, typically one size down, can be used compared to traditional designs with unilateral pinion bearings.

Along with the significantly increased power densities, a whole series of other positive factors impress:

- Pinion concentricity adjusted to ≤ 0.01 mm (optional)
- Linear backlash reduced to $\sim 50\%$
- Linear stiffness increased by $\sim 100\%$
- Optimized adaptation of the mass moment by means of a large variety of gear unit ratios and numbers of pinion teeth

Specific rack and pinion drives as complete, ready-to-use units

With helical geared planetary gear units

The ZTRS drives are based on the ServoFit® PH and PHA precision planetary gear units that are designed for very high requirements on torque as well as on torsional and tilting stiffness. The ratios range from $i = 4$ to $i = 121$ (up to 3 gear unit stages).



ME motor adapter for ZTRS-PH units with balanced EasyAdapt® motor coupling

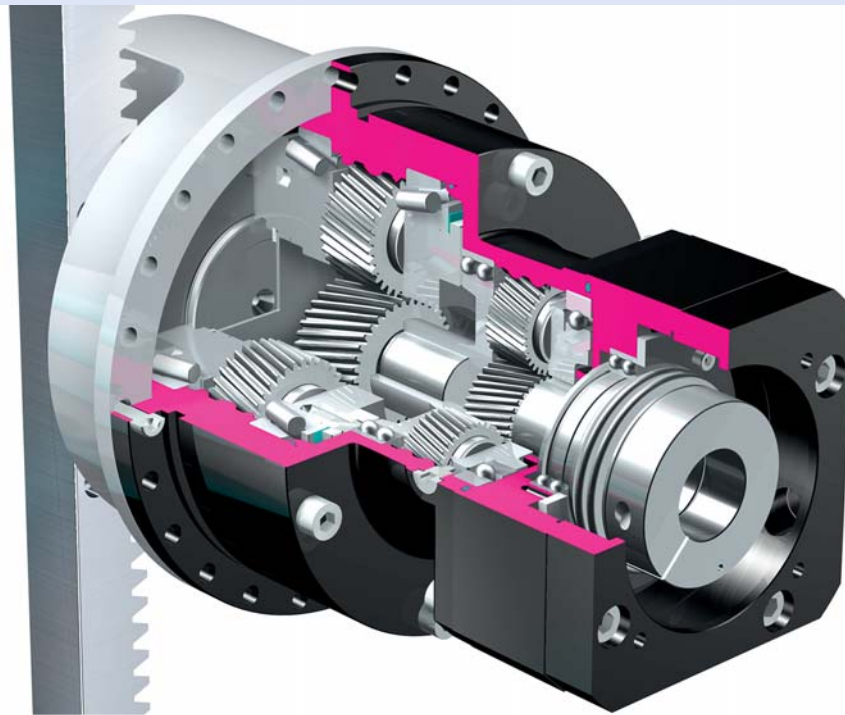

To see an animated film on HighForce ZTRS-PH features go to mediacenter.stoeber.de

ZTRS-PHA822 rack and pinion drive, two stage, with MF motor adapter

Balanced FlexiAdapt® clamp coupling for large motor shaft diameter with integrated thermal length compensation

Helical geared rack and pinion drives for highest requirements. Feed force up to 124 kN

Due to the variability of gear unit types, sizes, ratios, number of pinion teeth and gear rack modulus, perfectly optimized rack and pinion drives for **machine tools** and **automation systems** are achieved. STÖBER application consultants are of course available for optimal design.

Overview rack and pinion drives

Designation	Gear unit types	Features	Feed forces
ZTRS	PH7 to PH10 PHA7 to PHA10 PHQ10 to PHQA10	Torque reducer pinion with supporting bearing cover helical geared and straight-cut, module $m=2$ to $m=10$ hardened and ground to quality level 5	14.5 kN to 124 kN
ZTR	PH4 to PH10 PHA4 to PHA10	Torque reducer pinion helical geared and straight-cut, module $m=2$ to $m=8$ hardened and ground to quality level 5	4.7 kN to 60 kN
ZR	PH3 to PH7 PHA3 to PHA7	Large pinion with bolt circle holes helical geared, module $m=2$ to $m=4$ hardened and ground to quality level 5	2.1 kN to 12 kN

Ready-to-install solutions

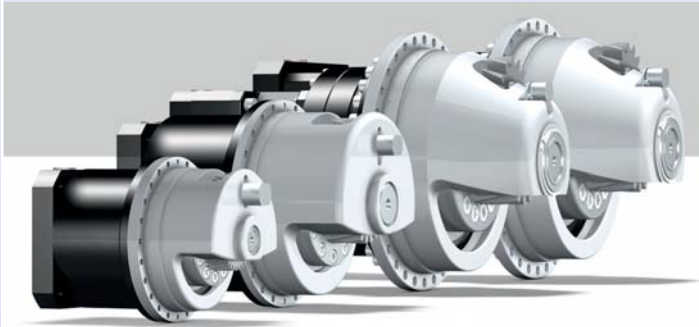

ZTRS-PH721
einstufig

ZTRS-PH821
einstufig

ZTRS-PH932
zweistufig

ZTRS-PH1032
zweistufig

Large or small pinion is no longer a question of mounting options

During the choice of the pinion size, the size of the pitch circle on the gear unit flange shaft no longer needs to be taken into account. Now flanged pinion with the lowest possible number of teeth can be used.

As a result the linear stiffness of the rack and pinion drive is increased by up to 100 %.

The pinion size affects the linear stiffness

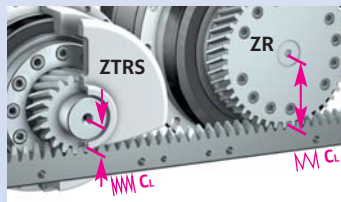
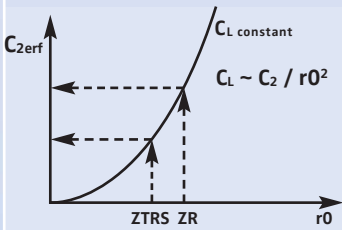

Linear stiffness through small lever arm



ZTR-PH with straight-cut flanged pinion



Flanged pinion hardened and ground to quality level 5 acc. to DIN3960/3961

Helical geared and straight-cut flanged pinions for use without and with output bearing housing

The complete range for rack and pinion drives

For the High-Force ZTRS-PH rack and pinion drive STÖBER also supplies straight-cut flanged pinions.

If the requirements for quality are not as exacting, the ZTR version can be used with spur or helical-toothed flanged pinions without shaft end.

Additionally, large-size helical-toothed pinions for bolt mounting without flange are available

With perfectly matched components

The complete solution from a single source

Due to the close co-operation with the world market leader and manufacturer of ATLANTA precision gear racks, STÖBER can offer comprehensive and uncompromisingly configured complete solutions.

The synergy effect of quality, precision and interaction of all components results in optimum functionality. As a result these rack and pinion drives are also suitable for the highest requirements.



ATLANTA series 29

Gearing:
Right-hand 19°31'42"
meshing angle 20°

Modulus 2 / 3 / 4 / 5 / 6 / 8 / 10 / 12
Quality 5 and 6
Teeth hardened and ground
All sides ground

ATLANTA series 48

Gearing:
Right-hand 19°31'42"
meshing angle 20°

Modulus 5 / 6 / 8 / 10 / 12
Quality 4
Teeth hardened and ground
All sides ground

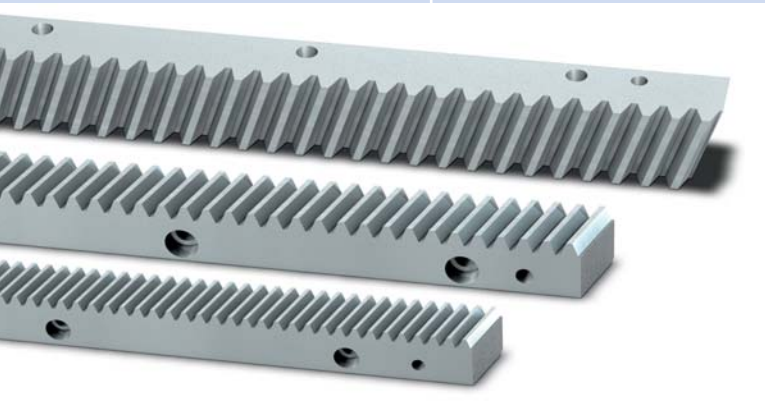

Precision gear racks
for assembly in series,
helical geared
Series 29
Modulus 2 / 3 / 4 / 5 / 6 / 8 / 10 / 12

All precision racks are
also available in
straight-cut versions



Precision gear racks
for assembly in series,
helical geared
Series 48
Modulus 5 / 6 / 8 / 10 / 12

The system axis as complete drive solution

The complete STÖBER system solution comprises optimally matched components and knowledgeable application experience.



① HighForce ZTRS-PH rack and pinion drive

This high performance drive comprises the rack and pinion drive HighForce ZTRS-PH and a directly attached EZ or ED/EK servo motor

② POSIDYN® SDS 5000 servo inverter

The system basis for the highest performance for torque, speed and position control. Has a secure remote maintenance function and a self-configuring Integrated Bus (IGB) for the communication between max. 32 servo inverters.

③ POSITool commissioning software

Universal user software for all functions from engineering to commissioning.

④ Connection cable

STÖBER provides a specially pre-assembled power and encoder cable for quick, correct assembly.

Service

The STÖBER service system comprises 38 expert partners in Germany and more than 80 companies in the STÖBER SERVICE NETWORK worldwide.

This service concept guarantees local expertise and availability when needed.

The concept is supplemented by the remote maintenance concept for the servo inverters in the POSIDYN® SDS 5000 series.

In general, the service specialists in the Pforzheim factory can be reached at any time via a 24/7 service hotline.

When necessary, a problem can be addressed immediately.

**24/7 service hotline
+49 (0)180 5 786323**

STÖBER DRIVES LTD.
CANNOCK WS12 2HA
UNITED KINGDOM
mail@stober.co.uk

STÖBER DRIVES, INC.
MAYSVILLE, KY 41056
USA
sales@stober.com

STÖBER ANTRIEBSTECHNIK GmbH
4663 LAAKIRCHEN
AUSTRIA
office@stoeber.at

STÖBER CHINA
BEIJING 100004
CHINA
info@stoeber.cn

STÖBER S.a.r.l.
69300 CALUIRE ET CUIRE
FRANCE
mail@stober.fr

STÖBER TRASMISSIONI s.r.l.
20017 MAZZO DI RHO (MILANO)
ITALY
info@stoeber.it

STÖBER Japan K. K.
TOKYO
JAPAN
mail@stober.co.jp

STÖBER Singapore
SINGAPORE 787494
SINGAPORE
info@stober.sg

STÖBER Schweiz AG
5453 REMETSCHWIL
SWITZERLAND
info@stoeber.ch

STÖBER ANTRIEBSTECHNIK GmbH + Co. KG

Kieselbronner Str. 12
75177 PFORZHEIM
GERMANY
Phone +49 (0)7231 582-0
Fax +49 (0)7231 582-1000
mail@stoeber.de
www.stoeber.de



STÖBER