

2011 ServoFit Catalog

STÖBER ServoFit Coorboards
2011



STÖBER
Geared to a higher standard™



ServoFit® Gearheads

Table of Contents

What's New in this Catalog?

IP69K

STOBER received certification in 2010 for the C, F, K, and KSS Series. See Page 280.



KL

A new right angle "K" Series in a smaller footprint available in hollow output (quill and wobble free double bushing), output shaft, mounting feet, output flange, and shrink ring configuration. See Page 258 for dimensions.



KSS

All stainless steel right angle helical bevel reducer in sizes that can be mounted on a shaft up to 1½ inches. Available with hollow output (quill and double bushing) and solid output shaft. Also available with mounting feet and output flange. See Page 281.



PHQ11

Additional size in the PHQ Series increases the torque capacity up to 194,000 in.lbs (22,000 Nm). See Page 137.



PHQK

The PHQ unit is available as a right angle using the "K" Series ServoFit Modular System providing high torsional stiffness, high torque capacity, high tilting moment, and low backlash. See Page 152.



P Series	
Performance Overview	4
Selection Data	10
Dimensional Data	18
PA Series	
Performance Overview	20
Selection Data	26
Dimensional Data	38
PKX Series	
Performance Overview	40
Selection Data	46
Dimensional Data	50
PK Series	
Performance Overview	52
Selection Data	58
Dimensional Data	68
PH Series	
Performance Overview	70
Selection Data	74
Dimensional Data	80
PHA Series	
Performance Overview	84
Selection Data	88
Dimensional Data	100
PHKX Series	
Performance Overview	102
Selection Data	106
Dimensional Data	112
PHK Series	
Performance Overview	114
Selection Data	118
Dimensional Data	128
PHQ Series	
Performance Overview	130
Selection Data	134
Dimensional Data	138
PHQA Series	
Performance Overview	140
Selection Data	144
Dimensional Data	150
PHQK Series	
Performance Overview	152
Selection Data	156
Dimensional Data	164
KS Series	
Performance Overview	166
Selection Data	172
Dimensional Data	174
PE Series	
Performance Overview	180
Selection Data	184
Dimensional Data	185
C Series	
Performance Overview	187
Selection Data	192
Dimensional Data	210
F Series	
Performance Overview	219
Selection Data	224
Dimensional Data	230
K Series	
Performance Overview	237
Selection Data	242
Dimensional Data	258
KSS Series	
Performance Overview	281
Selection Data	284
Dimensional Data	286
Miscellaneous	
Motor Mounting Instructions	292
Shrink Ring Installation	294
Wobble Free Bushing Installation	296
Hollow Output Installation	298
KSS Motor Mounting	299
ServoCool Motor Mounting	300
Selection Procedure	302

P
P
A
P
K
X
P
K

P
H
P
H
A
P
H
K
X
P
H
K

P
H
Q
P
H
Q
A
P
H
Q
K

K
S

P
E

C

F

K

K
S
S

M
I
S
C

ServoFit® Precision Planetary Gearhead Selection Guides – Inline and Offset



P and PA



PH and PHA



PHQ and PHQA



PE



C



F



Product	P	PA	PH	PHA	PHQ	PHQA	PE	C	F
---------	---	----	----	-----	-----	------	----	---	---

Typical Industries

Packaging	✓						✓	✓	✓
Machine Tool	✓	✓	✓	✓	✓	✓			✓
Robotics	✓	✓	✓	✓	✓	✓			
Material Handling	✓		✓				✓	✓	✓
Semi Conductor	✓		✓					✓	✓
Printing	✓	✓		✓		✓			
Converting	✓	✓	✓	✓	✓	✓		✓	
Food Processing	✓							✓	✓

Configurations

Offset									✓
Solid Shaft	✓	✓					✓	✓	✓
Hollow Bore Output									✓
Rotating Flange			✓	✓	✓	✓			
Input Shaft	✓	✓	✓	✓	✓	✓		✓	✓
ServoStop	✓	✓	✓	✓	✓	✓		✓	✓
Rack and Pinion	✓	✓	✓	✓					

Environment Options

Washdown	✓	✓						✓	✓
Beverage Duty	✓	✓						✓	✓
Food Duty	✓	✓						✓	✓
Extreme Food Duty — Stainless IP69K	✓	✓						✓	✓

Performance ¹⁾

Continuous RPM	+++	+++	++	++	++	++	++	+++	+++
Stiffness	+++	+++	++++	++++	+++++	+++++	++	+	+
Torque Density	+++	+++	++++	++++	+++++	+++++	++	+	+

Precision

1 ArcMinute Backlash		✓		✓		✓			
1-3 ArcMinutes Backlash	✓			✓		✓			
3-5 ArcMinutes Backlash			✓		✓				
5-10 ArcMinutes Backlash									
10-15 ArcMinutes Backlash							✓		✓
15-20 ArcMinutes Backlash								✓	✓

Nominal Output Torque Ranges – NM (In-lbs)

0-50 (0-450)	✓	✓	✓	✓			✓	✓	✓
50-200 (450-1,770)	✓	✓	✓	✓			✓	✓	✓
200-1,000 (1,770-8,850)	✓	✓	✓	✓	✓	✓		✓	✓
1,000-5,000 (8,850-45,000)	✓	✓	✓	✓	✓	✓		✓	✓
5,000-10,000 (45,000-88,500)			✓		✓	✓		✓	✓
10,000-23,000 (88,500-203,000)					✓	✓			✓

¹⁾ + Good.....+++++ Best



ServoFit® Precision Planetary Gearhead Selection Guides – Hollow and Right Angle



Product	PKX	PK	PHKX	PHK	PHQK	K	KL	KSS	KS
---------	-----	----	------	-----	------	---	----	-----	----

Typical Industries

Packaging	✓	✓	✓	✓	✓	✓	✓	✓	✓
Machine Tool	✓	✓	✓	✓	✓	✓	✓	✓	✓
Robotics	✓	✓	✓	✓	✓	✓	✓	✓	✓
Material Handling	✓	✓	✓	✓	✓	✓	✓	✓	✓
Semi Conductor	✓	✓	✓	✓	✓	✓	✓	✓	✓
Printing	✓	✓	✓	✓	✓	✓	✓	✓	✓
Converting	✓	✓	✓	✓	✓	✓	✓	✓	✓
Food Processing	✓	✓	✓	✓	✓	✓	✓	✓	✓

Configurations

Solid Shaft	✓	✓				✓	✓	✓	✓
Hollow Bore Output						✓	✓	✓	✓
Rotating Flange			✓	✓	✓				✓
Input Shaft		✓		✓	✓	✓			✓
ServoStop		✓		✓	✓	✓			✓
Rack and Pinion	✓	✓	✓	✓	✓	✓			✓

Environment Options

Washdown	✓	✓				✓	✓	✓	
Beverage Duty	✓	✓				✓	✓	✓	
Food Duty	✓	✓				✓	✓	✓	
Extreme Food Duty — Stainless IP69K	✓	✓				✓	✓	✓	

Performance ¹⁾

Continuous RPM	+	++	+	++	++	++++	++	+++	+++
Stiffness	+++	++	++++	+++	+++++	+	+	+	++
Torque Density	+++	++	+++	++	++++	+	+	+	++

Precision

1 ArcMinute Backlash		✓							
1-3 ArcMinutes Backlash	✓		✓	✓	✓	✓			✓
3-5 ArcMinutes Backlash									
5-10 ArcMinutes Backlash									
10-15 ArcMinutes Backlash								✓	
15-20 ArcMinutes Backlash							✓		

Nominal Output Torque Ranges – NM (In-lbs)

0-50 (0-450)	✓		✓		✓	✓	✓		
50-200 (450-1,770)	✓		✓		✓	✓	✓		✓
200-1,000 (1,770-8,850)	✓	✓	✓	✓	✓	✓	✓	✓	✓
1,000-5,000 (8,850-45,000)	✓	✓	✓	✓	✓	✓	✓		✓
5,000-10,000 (45,000-88,500)			✓		✓	✓	✓		
10,000-23,000 (88,500-203,000)					✓	✓	✓		

¹⁾ + Good.....+++++ Best

"P" Series

ServoFit® Precision Planetary Gearhead

Performance Specification Overview



		P221	P222	P321	P322	P421	P422	P521	P522	P721	P722	P821	P822	P921	P922
Acceleration Torque	in.lbs.	195		575		1052		2,655		6,195		14,160		26,570	
M _{2B} MAX	Nm	22		65		120		300		700		1,600		3,000	
Output Torque Nom. ¹⁾	in.lbs.	142		399		753		1,860		3,898		8,858		17,716	
M _{2N}	Nm	16		45		85		210		440		1,000		2,000	
Input Speed Max.	Continuous	4,500	4,500	4,500	4,500	4,000	4,500	3,700	4,000	3,300	3,700	2,800	3,300	2,500	2,800
n ₁ MAX	Cyclic	8,000	8,000	8,000	8,000	7,000	8,000	6,500	7,000	6,000	6,500	4,500	6,000	4,000	4,500
ServoCool															
Input Speed Max.	Continuous	—		—		4,500	—	5,500	4,500	5,000	5,000	4,500	4,500	4,000	4,000
n ₁ MAX	Cyclic	—		—		7,000	—	6,500	7,000	6,000	6,500	6,000	6,000	5,000	6,000
Torsional Backlash ²⁾															
Δφ	arcmin	≤6	≤8	≤4	≤5	≤4	≤5	≤3	≤4	≤3	≤4	≤3	≤4	≤3	≤4
Torsional Stiffness															
C ₂	in.lbs./arcmin	17		44		100		266		486		1,557		3,094	3,016
	Nm/arcmin	1.9		5		11		33		55		176		350	340
Axial Load Maximum	R	lbs.	112	225	337	518	653	1,058	1,350						
F _{2AMAX} ³⁾	D	lbs.	500	1,000	1,500	2,300	2,900	4,700	6,000						
	Z	lbs.	—	315	506	788	1,013	1,688	2,250						
		N	—	1,400	2,250	3,500	4,500	7,500	10,000						
		N	—	135	225	360	450	810	1,125						
		N	—	600	1,000	1,600	2,000	3,600	5,000						
Radial Load Maximum ⁴⁾	R	lbs.	270	563	900	1,463	1,800	2,925	4,050						
F _{2RMAX} ³⁾	D	lbs.	1,200	2,500	4,000	6,500	8,000	13,000	18,000						
	Z	lbs.	—	619	1,013	1,575	2,025	3,375	4,500						
		N	—	2,750	4,500	7,000	9,000	15,000	20,000						
		N	—	675	1,125	1,800	2,250	4,050	6,075						
		N	—	3,000	5,000	8,000	10,000	18,000	27,000						
Tilting Moment Maximum ⁴⁾	R	in.lbs.	300	779	1,416	2,991	4,774	5,938	14,735						
M _{2Kmax} ³⁾	D	in.lbs.	34	88	160	338	536	897	1,665						
	Z	in.lbs.	—	929	1,717	3,593	5,735	10,089	18,320						
		Nm	—	105	194	406	648	1,140	2,070						
		Nm	—	929	1,770	3,682	5,929	10,992	22,125						
		Nm	—	105	200	416	670	1,242	2,500						
Efficiency (at Nom. Torque)															
h	%	97%	95%	97%	95%	97%	95%	97%	95%	97%	95%	97%	95%	97%	95%
Weight	pounds	3	4.0	6	8	9	12	14	19	27	33	57	71	110	135
m	kg	1.2	1.8	2.6	3.5	4.0	5.3	6.5	8.5	12	15	26	32	50	61
Noise Level															
L _{PA}	dB(A) ⁵⁾	≤61	≤61	≤61	≤61	≤62	≤60	≤63	≤61	≤64	≤62	≤65	≤63	≤65	≤64
Balance Quality		Q 2.5 (Quality Class-2.5 millimeters per second)													
Lubrication		Synthetic Oil — Lubricated for Life													
Degree of Protection		IP65 - FKM Shaft Seals													
Mounting Position		Unrestricted													
Direction of Rotation		Input and Output Rotate the SAME Direction.													
Ambient Temperature		0° C to +40°C (104° F) [Unit temperature ≤ 90° C Max.]													
Finish		Black (Standard), Washdown (White), Food and Beverage (Stainless) Options Available													
Lifetime ⁶⁾	hours	L _h > 10,000 hours if M _{2K} /M _{2A} < 1.25 and > 1.00													
L _h		L _h > 20,000 hours if M _{2K} /M _{2A} > 1.25 and < 1.50													
		L _h > 30,000 hours if M _{2K} /M _{2A} > 1.5													
Warranty		5 Year Limited (2 Years on normal wear items: bearings, seals, etc.)													

¹⁾ Ratings based on input speed (n₁) of 2000 RPM.

For torque at higher input speeds (M_{2NX}) solve the formula, where n₁ = Actual Input Speed.
$$M_{2NX} = \frac{M_{2N}}{\sqrt[3]{\frac{n_1}{2000}}}$$

²⁾ Tested at 1.5% of nominal torque and recorded on the output side of the gearhead.
For reduced value see the PA Series.

³⁾ See Page 9 for output bearing options.

⁴⁾ Rating based on output speed (n₂) of 100 RPM. For values at other speeds see Page 8.

⁵⁾ Measurement at one (1) meter distance with input speed (n₁) of 2000 RPM.

⁶⁾ M_{2A} equals actual tilting moment of the application. See Page 8 for calculation details.

WARNING: In order to insure that the specified torque ratings are attained, it is essential to attach the gear units to the machine with a grade 10.9 fastener.

Refer to Page 302 for ServoFit Precision Planetary Gearhead Selection Procedure.



"P" Series ServoFit® Precision Planetary Gearhead Features

The "P" Series ServoFit Precision Planetary Gearheads feature HeliCamber® gearing and many other components which make them the most accurate and efficient planetary gearheads available. HeliCamber® gear technology provides minimum wear, low backlash and low noise. All units are lubricated for life with synthetic oil and sealed to IP65 standards to prevent lubricant contamination for long life.

- Some of these features are:
- Readily Attaches to Any Servo Motor (IEC, NEMA, or Customized Motor Plates*)
 - 5 Year Limited Warranty (2 years on bearings, seals, etc.)
 - Lowest Standard Backlash
 - High Torsional Stiffness
 - Advanced Gear Technology
 - 95 to 97% Efficiency
 - Quiet Running
 - Assembled in the U.S.A.

* Maximum 10 working days for custom motor plates.



NO EXPEDITE FEE FOR 24 HOUR SERVICE

Ring gear machined integral to the housing — not welded or pressed in — provides greater concentricity and eliminates speed fluctuation

Highest running smoothness achieved by proven helical gearing and gear tooth microgeometry. Gear quality provided by case-hardened and finish-ground sun and planet gears.

The patented motor coupling is designed to allow thermal expansion of the motor shaft — ensuring long motor life by preventing thrust load on the motor bearings.

The motor shaft adaption system allows installation of motor in minutes — no special tools required

Magnetic oil filtration

FKM seals — for the smallest possible diameter— reducing friction and heat buildup, increasing efficiency, and allowing continuous duty without additional cooling.

Triple-split collet — for greater concentricity and low inertia — is rated in excess of 200 percent of the gearheads input torque capacity

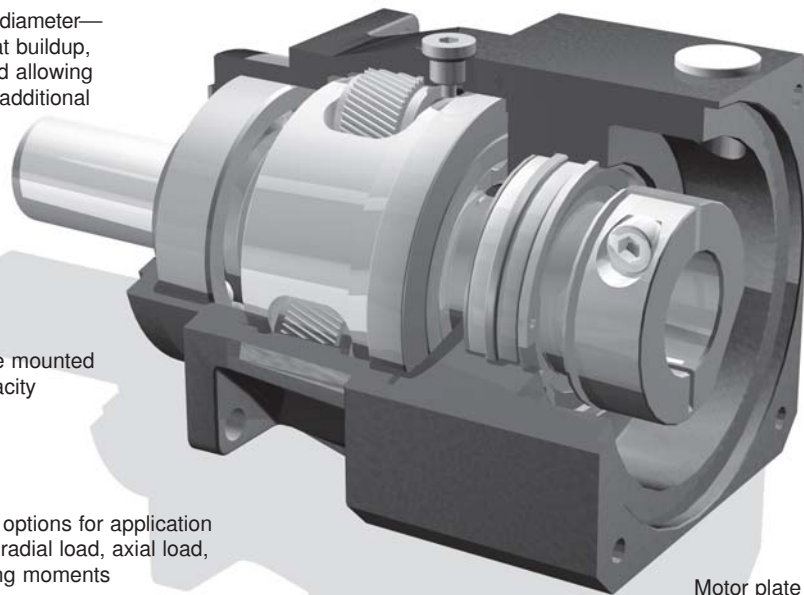

Adapter bushings to fit all motor shafts — no key required

Planet carrier straddle mounted for robust output capacity

Motor plate pilot toleranced to fit your motor for precise concentricity

Bearing options for application specific radial load, axial load, and tilting moments

Motor plate can easily be changed to fit your choice of motors

Highest running accuracy and precision ensured by single piece housing made from high-tensile tempered ductile iron with the additional characteristics of dissipating heat, noise dampening, and greater lubrication retention on the ring gear

"P" Series ServoFit® Precision Planetary Gearhead



Part No. Explanation

	<u>P</u>	<u>4</u>	<u>2</u>	<u>1</u>	<u>S</u>	<u>P</u>	<u>R</u>	<u>0030</u>	<u>MT</u>	<u>L</u>
	Series	Size	Generation	No. of Gear Stages	Housing	Output Option	Bearing Option	Ratio	Input	Input Option
Series	<u>P</u>									
Size		<u>4</u>								
Generation			<u>2</u>							
No. of Gear Stages				<u>1</u>						
Housing Style					<u>S</u>					
Output Shaft						<u>P</u>				
							<u>G</u>			
Bearing Option							<u>R</u>			
								<u>D</u>		
									<u>Z</u>	
Ratio								<u>0030</u>		
Motor Adapter									<u>MT</u>	
Option										<u>L</u>

Series **P** Planetary Gearhead

Size **4** 2, 3, **4**, 5, 7, 8, 9

Generation **2** First generation 1, second generation **2**, etc.

No. of Gear Stages **1** **1**, 2, (determined by the ratio)

Housing Style **S** Standard

Output Shaft **P** Shaft with Key



G — Plain Shaft (no key)

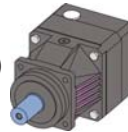

Bearing Option **R** Normal Bearing

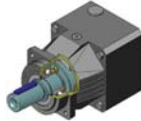

D — Reinforced Bearing (axial)

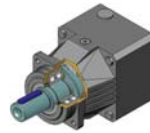

Z — Reinforced Bearing (radial)

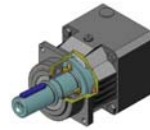

Ratio **0030** Approximate: 0030 = 3.00:1 (range of 3:1 up to 100:1)

Motor Adapter **MT** TriAdapt® Motor Adapter (Motor information must be specified.)

AW — Also, available with input shaft.



Option **L** Large Input



C — ServoCool (available in sizes P402 thru P922)





"P" Series ServoFit® Precision Planetary Gearhead

Motor Mounting Specifications

STOBER ServoFit Gearheads will fit the motor of your choice by assembling the correct motor mounting plate between the motor and the gearhead. **When ordering a gearhead, specify the motor manufacturer and part number, provide the motor drawing with dimensions, or specify the motor mounting dimensions.** The motor plate thickness (L^9) will be determined by the motor shaft length. The minimum motor plate thickness is shown below. For a precise dimension on a specific motor, contact STOBER Technical Support.

The following dimensions are required to provide the correct motor mounting plate:

1. D^6 Motor Shaft Diameter (If an adapter bushing is required it will be supplied with the motor plate.)
2. D^7 Pilot Diameter
3. D^8 Bolt Circle Diameter
4. D^9 Bolt Diameter
5. L^{11} Motor Shaft Length
6. L^{12} Pilot Length
7. L^{14} Square Flange (Optional — motor plate will typically be made to match this dimension.)

Table No. 1

Motor Plate Dims.	Planetary Size						
	P221 P222 P322	P221L P222L P321 P322L P422	P321L P421 P422L P522	P421L P521 P522L P722	P521L P721 P722L P822	P721L P821 P822L P922	P921 P922L
D^6 Max.	14	19	24	32	38	48	60
L^9 Min.	15	18	21	24	25	33	43

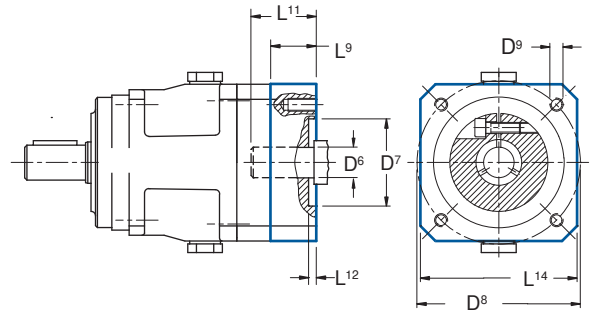

Output Shaft Options

The designation "P" or "G" for the output shaft must be included as part of the unit part number.

Table No. 2

P – Shaft with Key

Unit No.	D k6 mm	L ¹ mm inches	L ² mm inches	L ⁴ mm inches	S ² (1)	T mm inches	U (2)
P2	12 +.012/+0.001	2 .08	22 .87	36 1.42	M4	13.5 .53	A4x4x18
P3	16 +.012/+0.001	2 .08	28 1.10	48 1.89	M5	18 .71	A5x5x22
P4	22 +.015/+0.002	3 .11	36 1.42	56 2.20	M8	24.5 .96	A6x6x28
P5	32 +.018/+0.002	3 .11	58 2.28	88 3.46	M12	35 1.38	A10x8x50
P7	40 +.018/+0.002	4 .16	82 3.23	112 4.41	M16	43 1.69	A12x8x70
P8	55 +.021/+0.002	6 .24	82 3.23	112 4.41	M20	59 2.32	A16x10x70
P9	75 +.021/+0.002	7 .28	105 4.13	143 5.63	M20	79.5 3.13	A20x12x90

G – Shaft without Key

Unit No.	D k6 mm	L ² mm inches	L ⁴ mm inches	S ³ (1)
P2	12 +.012/+0.001	22 .87	36 1.42	R3.5x6.7
P3	16 +.012/+0.001	28 1.10	48 1.89	R4x8.5
P4	22 +.015/+0.002	36 1.42	56 2.20	R4x8.5
P5	32 +.018/+0.002	58 2.28	88 3.46	R4x8.5
P7	40 +.018/+0.002	82 3.23	112 4.41	R4x8.5
P8	55 +.021/+0.002	82 3.23	112 4.41	R5x10.6
P9	75 +.021/+0.002	105 4.13	143 5.63	M20

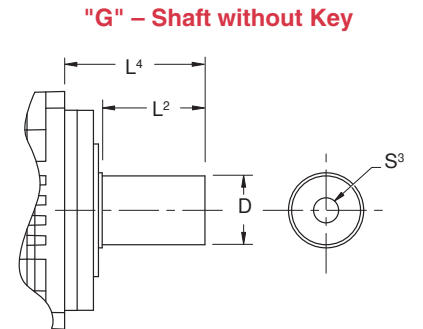
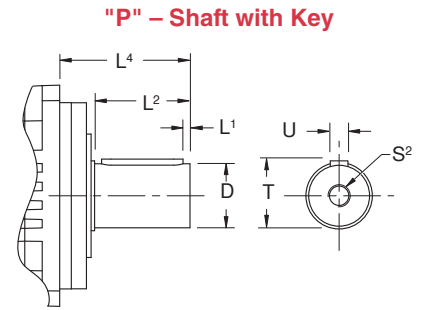

(1) The center hole in shafts with keys (Option "P") are machined to DIN 332 T2 shape DR.

(2) Feather keys are toleranced according to standard DIN 6885.

"P" Series ServoFit® Precision Planetary Gearhead Shaft Loads



All formulas shown are based on METRIC values.

Upper case letters are permissible values. Lower case letters are for existing values.

The permissible load and tilting moment values are based on an output speed of 100 RPM. For higher speeds the following applies, where n_2 is the desired speed:

$$F_{2AX} = \frac{F_{2A}}{\sqrt[3]{\frac{n_2}{100}}} \quad F_{2RX} = \frac{F_{2R}}{\sqrt[3]{\frac{n_2}{100}}} \quad M_{2KX} = \frac{M_{2K}}{\sqrt[3]{\frac{n_2}{100}}}$$

The application input tilting moment should be determined by the following formula:

$$M_{2A} = \frac{2 \cdot F_{2a} \cdot y_2 + F_{2rb} \cdot (x_2 + z_2)}{1000} \leq M_{2KB}$$

$$M_{2ka} = \sqrt[3]{\frac{n_{2b1} \cdot t_{b1} \cdot M_{2kb1}^3 + \dots + n_{2bn} \cdot t_{bn} \cdot M_{2kbn}^3}{n_{2b1} \cdot t_{b1} + \dots + n_{2bn} \cdot t_{bn}}} \leq M_{2K}$$

$$F_{2r} = \sqrt[3]{\frac{n_{2b1} \cdot t_{b1} \cdot F_{2rb1}^3 + \dots + n_{2bn} \cdot t_{bn} \cdot F_{2rbn}^3}{n_{2b1} \cdot t_{b1} + \dots + n_{2bn} \cdot t_{bn}}} \leq F_{2R}$$

- where:
- F_{2a} Axial Load at Output Shaft
 - F_{2A} Permissible Axial Load
 - F_{2r} Radial Load at Output Shaft
 - F_{2R} Permissible Radial Load
 - F_{2RB} Acceleration Permissible Radial Load
 - M_{2K} Rated Tilting Torque
 - M_{2k} Equivalent Tilting Load
 - M_{2KB} Acceleration Tilting Torque
 - z_2 Distance Factor

The hours of life (L_h) of the unit can be determined by the following formula:

bearing life for duty cycle ≤ 40%

- $L_h > 10,000$ hours if $M_{2k}/M_{2A} < 1.25$ and > 1
- $L_h > 20,000$ hours if $M_{2k}/M_{2A} > 1.25$ and > 1.5
- $L_h > 30,000$ hours if $M_{2k}/M_{2A} < 1.5$

bearing life for duty cycle ≥ 40%

$$L_{hA} = L_h \left(\frac{40\%}{\text{Duty Cycle}} \right)$$

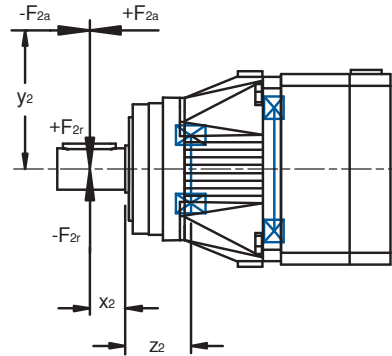

Table No. 1 Permissible Output Shaft Load and Tilting Moments

R – Output Bearing Option, Normal												
Unit No.	z_2		F_{2A}		F_{2R}		F_{2RB}		M_{2K}		M_{2KB}	
	mm	inches	N	lbs.	N	lbs.	N	lbs.	Nm	in.lbs.	Nm	in.lbs.
P2	17	.669	500	112	1,200	270	1,300	293	34	300	36	319
P3	21	.827	1,000	225	2,500	563	2,500	563	88	779	88	779
P4	22	.866	1,500	337	4,000	900	4,500	1,013	160	1,416	180	1,593
P5	23	.906	2,300	518	6,500	1,463	7,000	1,575	338	2,708	364	3,221
P7	26	1.023	2,900	653	8,000	1,800	9,000	2,025	536	4,744	603	5,337
P8	28	1.102	4,700	1,058	13,000	2,925	18,000	4,050	897	7,938	1,242	10,992
P9	40	1.575	6,000	1,350	18,000	4,050	27,000	6,075	1,665	14,735	2,498	22,107

D – Output Bearing Option, Axially Reinforced												
Unit No.	z_2		F_{2A}		F_{2R}		F_{2RB}		M_{2K}		M_{2KB}	
	mm	inches	N	lbs.	N	lbs.	N	lbs.	Nm	in.lbs.	Nm	in.lbs.
P3	24	.945	1,400	315	2,750	619	2,750	619	105	929	105	929
P4	25	.984	2,250	506	4,500	1,013	5,000	1,125	194	1,717	215	1,903
P5	29	1.142	3,500	788	7,000	1,575	8,000	1,800	406	3,593	464	4,106
P7	31	1.220	4,500	1,013	9,000	2,025	10,000	2,250	648	5,735	720	6,372
P8	35	1.378	7,500	1,688	15,000	3,375	18,000	4,050	1,140	10,089	1,368	12,107
P9	51	2.008	10,000	2,250	20,000	4,500	30,000	6,750	2,070	18,320	3,105	27,479

Z – Output Bearing Option, Radially Reinforced												
Unit No.	z_2		F_{2A}		F_{2R}		F_{2RB}		M_{2K}		M_{2KB}	
	mm	inches	N	lbs.	N	lbs.	N	lbs.	Nm	in.lbs.	Nm	in.lbs.
P3	21	.83	600	135	3,000	675	3,000	675	105	929	105	929
P4	22	.87	1,000	225	5,000	1,125	5,000	1,125	200	1,770	200	1,770
P5	23	.91	1,600	360	8,000	1,800	8,000	1,800	416	3,682	416	3,682
P7	26	1.02	2,000	450	10,000	2,250	10,000	2,250	670	5,929	670	5,929
P8	28	1.10	3,600	810	18,000	4,050	18,000	4,050	1,242	10,992	1,242	10,992
P9	40	1.58	5,000	1,125	27,000	6,075	35,000	7,875	2,500	22,125	3,238	28,656

During EMERGENCY OFF operation (maximum stops per gearhead = 1000) the permissible values in the table for F_{2A} , F_{2R} , and M_{2K} can be multiplied by a factor of 2.

The permissible load values given are valid with the load applied to the center of the output shaft (x_2).



"P" Series ServoFit® Precision Planetary Gearhead Shaft Loads

Output Bearing Options

"R" – Deep Groove Ball Bearing

Characteristics:

Minimal frictional torque
Good Radial load capacity
Axial load approx. 35% of radial load

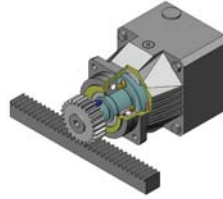

Applications:

Spur geared rack/pinion
Couplings
Belt with or without light tension

"D" – Double Row Angular Contact Ball Bearing

Characteristics:

Low frictional torque
Good radial bearing capacity
Axial load approx. 50% of radial load

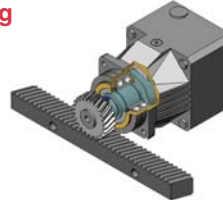

Applications:

Helical geared rack/pinion
Couplings with high axial load
Belt with or without light tension

"Z" – Cylindrical Roller Bearing

Characteristics:

Very good radial load capacity
Axial load approx. 20% of radial load

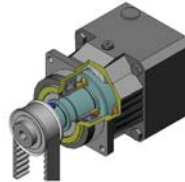

Applications:

Prestressed belt drive
Prestressed spur rack drive
Applications with high radial loads
and/or high service requirements

Permissible Motor Tilting Torque

The permissible tilting torque of the motor attached to the gear unit is a result of the static and dynamic load "F" from the motor weight, mass acceleration, and vibration multiplied by the distance from the center of gravity "Is" of the motor.

$$M_{1k} = F \times I_s \leq M_{1k}$$

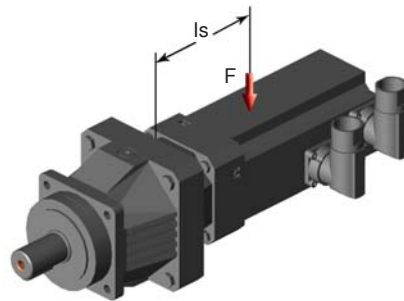

Table No. 2

M_{1k}

Unit Type with MT	Nm	inlbs.
P221, P222, P322	10	88.5
P321, P422	20	177
P421, P522	40	354
P521, P722	80	708
P721, P822	200	1,770
P821, P922	400	3,540
P921	800	7,080

No Load Running Torque

Table No. 3

"P" Series Input – T_R

Unit No.	Ratio																
	3	4	5	7	8	10	15	16	20	25	28	32	35	40	50	70	100
P2 in.lbs.	—	1.8	1.8	1.8	1.8	.9	—	.9	.9	.9	.9	.9	.9	.9	.9	.9	.9
Nm.		.2	.2	.2	.2	.1		.1	.1	.1	.1	.1	.1	.1	.1	.1	.1
P3 in.lbs.	2.7	1.8	1.8	1.8	1.8	.9	.9	.9	.9	.9	.9	.9	.9	.9	.9	.9	.9
Nm.	.3	.2	.2	.2	.2	.1	.1	.1	.1	.1	.1	.1	.1	.1	.1	.1	.1
P4 in.lbs.	3.5	2.7	2.7	1.8	1.8	1.8	.9	.9	.9	.9	.9	.9	.9	.9	.9	.9	.9
Nm.	.4	.3	.3	.2	.2	.2	.1	.1	.1	.1	.1	.1	.1	.1	.1	.1	.1
P5 in.lbs.	7.0	5.3	4.4	3.5	2.7	2.7	2.7	2.7	2.7	1.8	1.8	1.8	1.8	1.8	1.8	1.8	1.8
Nm.	.8	.6	.5	.4	.3	.3	.3	.3	.3	.2	.2	.2	.2	.2	.2	.2	.2
P7 in.lbs.	8.0	6.2	5.3	4.4	3.5	3.5	2.7	2.7	2.7	1.8	1.8	1.8	1.8	1.8	1.8	1.8	1.8
Nm.	.9	.7	.6	.5	.4	.4	.3	.3	.3	.2	.2	.2	.2	.2	.2	.2	.2
P8 in.lbs.	14.2	11.5	9.7	8.0	6.2	6.2	5.3	5.3	4.4	4.4	3.5	3.5	3.5	3.5	3.5	3.5	3.5
Nm.	1.6	1.3	1.1	.9	.7	.7	.3	.6	.5	.5	.4	.4	.4	.4	.4	.4	.4
P9 in.lbs.	—	17.7	17.7	17.7	—	11	—	11	11	11	11	—	11	11	11	11	11
Nm.		2	2	2		1.25		1.25	1.25	1.25	1.25		1.25	1.25	1.25	1.25	1.25

The torque is measured with the input at 2000 RPM and an ambient temperature of 20° C.



"P" Series ServoFit® Precision Planetary Gearhead Selection Data



Part Number (Gearhead + Input)	Exact Ratio i	Maximum Input Speed		Maximum Motor Shaft øD ⁶ mm	Input ¹⁾ Inertia J ₁ kgcm ²	Torsional Stiffness per arcmin C ₂		Output Torque					
		Continuous RPM (n ₁)	Cyclic RPM (n ₁)			in.lbs.	Nm	Nominal ²⁾ M _{2N}		Acceleration M _{2B}		Peak ³⁾ M _{2PEAK}	
								in.lbs.	Nm	in.lbs.	Nm	in.lbs.	Nm

P221 with Motor Mounting Plate

P221S_0040 MT	4.000	4,500	8,000	14	0.14	16.2	1.8	142	16	195	22	390	44
P221S_0040 MTL	4.000	4,500	8,000	19	0.61	16.8	1.9	142	16	195	22	390	44
P221S_0050 MT	5.000	4,500	8,000	14	0.12	16.4	1.9	142	16	195	22	390	44
P221S_0050 MTL	5.000	4,500	8,000	19	0.59	16.8	1.9	142	16	195	22	390	44
P221S_0070 MT	7.000	4,500	8,000	14	0.11	15.7	1.8	142	16	195	22	390	44
P221S_0070 MTL	7.000	4,500	8,000	19	0.57	15.9	1.8	142	16	195	22	390	44
P221S_0080 MT	8.000	4,500	8,000	14	0.10	14.9	1.7	124	14	159	18	319	36
P221S_0080 MTL	8.000	4,500	8,000	19	0.57	15.1	1.7	124	14	159	18	319	36
P221S_0100 MT	10.00	4,500	8,000	14	0.10	14.1	1.6	106	12	159	18	319	36
P221S_0100 MTL	10.00	4,500	8,000	19	0.56	14.2	1.6	106	12	159	18	319	36

P222 with Motor Mounting Plate

P222S_0160 MT	16.00	4,500	8,000	14	0.14	15.8	1.8	142	16	195	22	390	44
P222S_0160 MTL	16.00	4,500	8,000	19	0.61	15.8	1.8	142	16	195	22	390	44
P222S_0200 MT	20.00	4,500	8,000	14	0.14	16.2	1.8	142	16	195	22	390	44
P222S_0200 MTL	20.00	4,500	8,000	19	0.61	16.2	1.8	142	16	195	22	390	44
P222S_0250 MT	25.00	4,500	8,000	14	0.12	16.2	1.8	142	16	195	22	390	44
P222S_0250 MTL	25.00	4,500	8,000	19	0.59	16.2	1.8	142	16	195	22	390	44
P222S_0280 MT	28.00	4,500	8,000	14	0.11	15.8	1.8	142	16	195	22	390	44
P222S_0280 MTL	28.00	4,500	8,000	19	0.57	15.8	1.8	142	16	195	22	390	44
P222S_0320 MT	32.00	4,500	8,000	14	0.13	14.8	1.7	124	14	159	18	319	36
P222S_0320 MTL	32.00	4,500	8,000	19	0.60	14.9	1.7	124	14	159	18	319	36
P222S_0350 MT	35.00	4,500	8,000	14	0.11	16.1	1.8	142	16	195	22	390	44
P222S_0350 MTL	35.00	4,500	8,000	19	0.57	16.1	1.8	142	16	195	22	390	44
P222S_0400 MT	40.00	4,500	8,000	14	0.10	15.7	1.8	142	16	195	22	390	44
P222S_0400 MTL	40.00	4,500	8,000	19	0.56	15.7	1.8	142	16	195	22	390	44
P222S_0500 MT	50.00	4,500	8,000	14	0.10	16.1	1.8	142	16	195	22	390	44
P222S_0500 MTL	50.00	4,500	8,000	19	0.56	16.1	1.8	142	16	195	22	390	44
P222S_0700 MT	70.00	4,500	8,000	14	0.10	15.6	1.8	142	16	195	22	390	44
P222S_0700 MTL	70.00	4,500	8,000	19	0.56	15.6	1.8	142	16	195	22	390	44
P222S_1000 MT	100.0	4,500	8,000	14	0.10	14.0	1.6	106	12	159	18	319	36
P222S_1000 MTL	100.0	4,500	8,000	19	0.56	14.0	1.6	106	12	159	18	319	36

¹⁾ Inertia based on maximum input. For lower inertia using smaller diameter input, contact STOBER.

²⁾ Based on input speed: n₁ = 2000 RPM

For torque at higher input speeds (M_{2NX}) solve the formula, where n₁ = Actual Input Speed.
$$M_{2NX} = \frac{M_{2N}}{\sqrt[3]{\frac{n_1}{2000}}}$$

³⁾ Maximum momentary torque for emergency stops or heavy shock load. Admissible stops per life of gearhead = 1,000 stops maximum.



"P" Series ServoFit® Precision Planetary Gearhead Selection Data



P

Part Number (Gearhead + Input)	Exact Ratio i	Maximum Input Speed		Maximum Motor Shaft øD ⁶ mm	Input ¹⁾ Inertia J ₁ kgcm ²	Torsional Stiffness per arcmin C ₂		Output Torque					
		Continuous RPM (n ₁)	Cyclic RPM (n ₁)			in.lbs.	Nm	Nominal ²⁾ M _{2N}		Acceleration M _{2B}		Peak ³⁾ M _{2PEAK}	
								in.lbs.	Nm	in.lbs.	Nm	in.lbs.	Nm

P321 with Motor Mounting Plate

P321S_0030 MT	3.000	3,500	6,000	19	0.77	50.5	5.7	266	30	443	50	1,083	122
P321S_0030 MTL	3.000	3,500	6,000	24	1.45	50.5	5.7	266	30	443	50	1,083	122
P321S_0040 MT	4.000	3,700	6,500	19	0.69	46.9	5.3	399	45	576	65	1,152	130
P321S_0040 MTL	4.000	3,700	6,500	24	1.37	46.9	5.3	399	45	576	65	1,152	130
P321S_0050 MT	5.000	4,000	7,000	19	0.64	45.2	5.1	399	45	576	65	1,152	130
P321S_0050 MTL	5.000	4,000	7,000	24	1.32	45.2	5.1	399	45	576	65	1,152	130
P321S_0070 MT	7.000	4,500	8,000	19	0.59	39.0	4.4	399	45	531	60	1,152	130
P321S_0070 MTL	7.000	4,500	8,000	24	1.26	39.0	4.4	399	45	531	60	1,152	130
P321S_0080 MT	8.000	4,500	8,000	19	0.58	37.2	4.2	354	40	443	50	886	100
P321S_0080 MTL	8.000	4,500	8,000	24	1.25	37.2	4.2	354	40	443	50	886	100
P321S_0100 MT	10.00	4,500	8,000	19	0.57	35.4	4.0	266	30	443	50	886	100
P321S_0100 MTL	10.00	4,500	8,000	24	1.24	35.4	4.0	266	30	443	50	886	100

P322 with Motor Mounting Plate

P322S_0150 MT	15.00	4,500	8,000	14	0.14	39.7	4.5	266	30	443	50	1,082	122
P322S_0150 MTL	15.00	4,500	8,000	19	0.46	39.7	4.5	266	30	443	50	1,082	122
P322S_0160 MT	16.00	4,500	8,000	14	0.14	39.7	4.5	399	45	576	65	1,152	130
P322S_0160 MTL	16.00	4,500	8,000	19	0.61	40.0	4.5	399	45	576	65	1,152	130
P322S_0200 MT	20.00	4,500	8,000	14	0.14	40.6	4.6	399	45	576	65	1,152	130
P322S_0200 MTL	20.00	4,500	8,000	19	0.61	40.8	4.6	399	45	576	65	1,152	130
P322S_0250 MT	25.00	4,500	8,000	14	0.12	40.7	4.6	399	45	576	65	1,152	130
P322S_0250 MTL	25.00	4,500	8,000	19	0.59	40.8	4.6	399	45	576	65	1,152	130
P322S_0280 MT	28.00	4,500	8,000	14	0.11	39.5	4.5	399	45	576	65	1,152	130
P322S_0280 MTL	28.00	4,500	8,000	19	0.57	39.6	4.5	399	45	576	65	1,152	130
P322S_0320 MT	32.00	4,500	8,000	14	0.14	35.9	4.1	354	40	443	50	886	100
P322S_0320 MTL	32.00	4,500	8,000	19	0.61	36.0	4.1	354	40	443	50	886	100
P322S_0350 MT	35.00	4,500	8,000	14	0.11	40.5	4.6	399	45	576	65	1,152	130
P322S_0350 MTL	35.00	4,500	8,000	19	0.57	40.6	4.6	399	45	576	65	1,152	130
P322S_0400 MT	40.00	4,500	8,000	14	0.10	38.8	4.4	399	45	576	65	1,152	130
P322S_0400 MTL	40.00	4,500	8,000	19	0.56	38.9	4.4	399	45	576	65	1,152	130
P322S_0500 MT	50.00	4,500	8,000	14	0.10	40.0	4.5	399	45	576	65	1,152	130
P322S_0500 MTL	50.00	4,500	8,000	19	0.56	40.1	4.5	399	45	576	65	1,152	130
P322S_0700 MT	70.00	4,500	8,000	14	0.10	36.9	4.2	399	45	531	60	1,152	130
P322S_0700 MTL	70.00	4,500	8,000	19	0.56	36.9	4.2	399	45	531	60	1,152	130
P322S_1000 MT	100.0	4,500	8,000	14	0.10	34.6	3.9	266	30	443	50	886	100
P322S_1000 MTL	100.0	4,500	8,000	19	0.56	34.6	3.9	266	30	443	50	886	100

Index of Symbols: **MT** — Motor adapter with TriAdapt® coupling; **MF** — Motor adapter with FlexiAdapt® coupling; **L** — Large Input; **C** — ServoCool

See Page 6 for Options and Part Number Configuration.



"P" Series ServoFit® Precision Planetary Gearhead Selection Data



Part Number (Gearhead + Input)	Exact Ratio i	Maximum Input Speed		Maximum Motor Shaft øD ⁶ mm	Input ¹⁾ Inertia J ₁ kgcm ²	Torsional Stiffness per arcmin C ₂		Output Torque					
		Continuous RPM (n ₁)	Cyclic			Nominal ²⁾		Acceleration		Peak ³⁾			
						M _{2N}	M _{2B}	M _{2N}	M _{2B}	M _{2PEAK}	M _{2PEAK}		
Gearhead						in.lbs.	Nm	in.lbs.	Nm	in.lbs.	Nm	in.lbs.	Nm

P421 with Motor Mounting Plate

P421S_0030 MT	3.000	3,000	5,500	24	1.94	110.7	12.5	443	50	886	100	2,126	240
P421S_0030 MTC	3.000	3,500	6,000	24	2.66	98.3	11.1	443	50	886	100	1,289	146
P421S_0030 MTL	3.000	3,000	5,500	32	4.16	110.7	12.5	443	50	886	100	2,126	240
P421S_0040 MT	4.000	3,300	6,000	24	1.54	106.3	12.0	753	85	1,063	120	2,126	240
P421S_0040 MTC	4.000	3,800	6,000	24	2.27	99.5	11.2	753	85	1,063	120	1,718	194
P421S_0040 MTL	4.000	3,300	6,000	32	3.77	106.3	12.0	753	85	1,063	120	2,126	240
P421S_0050 MT	5.000	3,700	6,500	24	1.44	103.6	11.7	753	85	1,063	120	2,126	240
P421S_0050 MTC	5.000	4,200	6,500	24	2.16	99.4	11.2	753	85	1,063	120	2,126	240
P421S_0050 MTL	5.000	3,700	6,500	32	3.66	103.6	11.7	753	85	1,063	120	2,126	240
P421S_0070 MT	7.000	4,000	7,000	24	1.31	89.5	10.1	753	85	974	110	2,126	240
P421S_0070 MTC	7.000	4,500	7,000	24	2.05	87.8	9.9	753	85	974	110	2,126	240
P421S_0070 MTL	7.000	4,000	7,000	32	3.57	89.5	10.1	753	85	974	110	2,126	240
P421S_0080 MT	8.000	4,000	7,000	24	1.29	84.2	9.5	709	80	886	100	1,772	200
P421S_0080 MTC	8.000	4,500	7,000	24	2.03	83.0	9.4	709	80	886	100	1,772	200
P421S_0080 MTL	8.000	4,000	7,000	32	3.55	84.2	9.5	709	80	886	100	1,772	200
P421S_0100 MT	10.00	4,000	7,000	24	1.27	79.7	9.0	531	60	886	100	1,772	200
P421S_0100 MTC	10.00	4,500	7,000	24	2.01	79.1	8.9	531	60	886	100	1,772	200
P421S_0100 MTL	10.00	4,000	7,000	32	3.53	79.7	9.0	531	60	886	100	1,772	200

P422 with Motor Mounting Plate

P422S_0150 MT	15.00	3,700	6,500	19	.52	92.2	10.4	443	50	885	100	2,124	240
P422S_0150 MTL	15.00	3,700	6,500	24	1.07	92.2	10.4	443	50	885	100	2,124	240
P422S_0160 MT	16.00	3,700	6,500	19	0.71	93.1	10.5	753	85	1,063	120	2,126	240
P422S_0160 MTL	16.00	3,700	6,500	24	1.39	93.1	10.5	753	85	1,063	120	2,126	240
P422S_0200 MT	20.00	3,700	6,500	19	0.70	95.2	10.8	753	85	1,063	120	2,126	240
P422S_0200 MTL	20.00	3,700	6,500	24	1.38	95.2	10.8	753	85	1,063	120	2,126	240
P422S_0250 MT	25.00	4,000	7,000	19	0.65	94.9	10.7	753	85	1,063	120	2,126	240
P422S_0250 MTL	25.00	4,000	7,000	24	1.33	94.9	10.7	753	85	1,063	120	2,126	240
P422S_0280 MT	28.00	4,500	8,000	19	0.60	90.8	10.3	753	85	1,063	120	2,126	240
P422S_0280 MTL	28.00	4,500	8,000	24	1.27	90.8	10.3	753	85	1,063	120	2,126	240
P422S_0320 MT	32.00	3,700	6,500	19	0.69	81.9	9.2	709	80	886	100	1,772	200
P422S_0320 MTL	32.00	3,700	6,500	24	1.37	81.9	9.2	709	80	886	100	1,772	200
P422S_0350 MT	35.00	4,500	8,000	19	0.60	93.7	10.6	753	85	1,063	120	2,126	240
P422S_0350 MTL	35.00	4,500	8,000	24	1.27	93.7	10.6	753	85	1,063	120	2,126	240
P422S_0400 MT	40.00	4,500	8,000	19	0.58	89.5	10.1	753	85	1,063	120	2,126	240
P422S_0400 MTL	40.00	4,500	8,000	24	1.25	89.5	10.1	753	85	1,063	120	2,126	240
P422S_0500 MT	50.00	4,500	8,000	19	0.58	92.8	10.5	753	85	1,063	120	2,126	240
P422S_0500 MTL	50.00	4,500	8,000	24	1.25	92.8	10.5	753	85	1,063	120	2,126	240
P422S_0700 MT	70.00	4,500	8,000	19	0.58	85.1	9.6	753	85	974	110	2,126	240
P422S_0700 MTL	70.00	4,500	8,000	24	1.25	85.1	9.6	753	85	974	110	2,126	240
P422S_1000 MT	100.0	4,500	8,000	19	0.58	78.0	8.8	531	60	886	100	1,772	200
P422S_1000 MTL	100.0	4,500	8,000	24	1.25	78.0	8.8	531	60	886	100	1,772	200

¹⁾ Inertia based on maximum input. For lower inertia using smaller diameter input, contact STOBER.

²⁾ Based on input speed: n₁ = 2000 RPM

For torque at higher input speeds (M_{2NX}) solve the formula, where n₁ = Actual Input Speed.
$$M_{2NX} = \frac{M_{2N}}{\sqrt[3]{\frac{n_1}{2000}}}$$

³⁾ Maximum momentary torque for emergency stops or heavy shock load. Admissible stops per life of gearhead = 1,000 stops maximum.



"P" Series ServoFit® Precision Planetary Gearhead Selection Data



P

Part Number (Gearhead + Input)	Exact Ratio i	Maximum Input Speed		Maximum Motor Shaft øD ⁶ mm	Input ¹⁾ Inertia J ₁ kgcm ²	Torsional Stiffness per arcmin		Output Torque					
		Continuous RPM (n ₁)	Cyclic			C ₂		Nominal ²⁾		Acceleration		Peak ³⁾	
						in.lbs.	Nm	M _{2N}	Nm	M _{2B}	Nm	M _{2PEAK}	Nm

P521 with Motor Mounting Plate

P521S_0030 MT	3.000	2,500	4,500	32	4.76	321.5	36.3	1,063	120	1,772	200	3,686	416
P521S_0030 MTC	3.000	3,500	6,000	32	6.98	262.7	29.7	1,063	120	1,772	200	2,294	259
P521S_0030 MTL	3.000	2,500	4,500	38	7.79	321.5	36.3	1,063	120	1,772	200	3,686	416
P521S_0040 MT	4.000	3,000	5,000	32	4.55	284.3	32.1	1,860	210	2,657	300	4,915	555
P521S_0040 MTC	4.000	4,000	6,000	32	6.77	255.8	28.9	1,860	210	2,447	276	3,059	345
P521S_0040 MTL	4.000	3,000	5,000	38	7.57	284.3	32.1	1,860	210	2,657	300	4,915	555
P521S_0050 MT	5.000	3,500	6,000	32	4.14	275.5	31.1	1,860	210	2,657	300	5,315	600
P521S_0050 MTC	5.000	4,500	6,000	32	6.36	257.7	29.1	1,860	210	2,657	300	3,824	432
P521S_0050 MTL	5.000	3,500	6,000	38	7.16	275.5	31.1	1,860	210	2,657	300	5,315	600
P521S_0070 MT	7.000	3,700	6,500	32	3.74	248.0	28.0	1,860	210	2,392	270	5,315	600
P521S_0070 MTC	7.000	4,500	6,500	32	5.98	240.4	27.1	1,860	210	2,392	270	5,315	600
P521S_0070 MTL	7.000	3,700	6,500	38	6.79	248.0	28.0	1,860	210	2,392	270	5,315	600
P521S_0080 MT	8.000	3,700	6,500	32	3.67	230.3	26.0	1,772	200	2,215	250	4,429	500
P521S_0080 MTC	8.000	5,000	6,500	32	5.91	225.2	25.4	1,772	200	2,215	250	4,429	500
P521S_0080 MTL	8.000	3,700	6,500	38	6.72	230.3	26.0	1,772	200	2,215	250	4,429	500
P521S_0100 MT	10.00	3,700	6,500	32	3.61	221.5	25.0	1,240	140	2,215	250	4,429	500
P521S_0100 MTC	10.00	5,500	6,500	32	5.85	218.4	24.7	1,240	140	2,215	250	4,429	500
P521S_0100 MTL	10.00	3,700	6,500	38	6.66	221.5	25.0	1,240	140	2,215	250	4,429	500

P522 with Motor Mounting Plate Continued Next Page

P522S_0150MT	15.00	3,300	6,000	24	1.22	241.5	27.3	1,062	120	1,770	200	3,683	416
P522S_0150MTC	15.00	3,800	6,000	24	2.29	241.5	27.3	1,062	120	1,770	200	3,683	416
P522S_0150MTL	15.00	3,300	6,000	32	3.13	241.5	27.3	1,062	120	1,770	200	3,683	416
P522S_0160 MT	16.00	3,300	6,000	24	1.59	243.6	27.5	1,860	210	2,657	300	4,915	555
P522S_0160 MTC	16.00	3,800	6,000	24	2.32	241.3	27.2	1,860	210	2,657	300	4,915	555
P522S_0160 MTL	16.00	3,300	6,000	32	3.82	243.6	27.5	1,860	210	2,657	300	4,915	555
P522S_0200 MT	20.00	3,300	6,000	24	1.57	249.6	28.2	1,860	210	2,657	300	5,315	600
P522S_0200 MTC	20.00	3,800	6,000	24	2.29	248.0	28.0	1,860	210	2,657	300	5,315	600
P522S_0200 MTL	20.00	3,300	6,000	32	3.79	249.6	28.2	1,860	210	2,657	300	5,315	600
P522S_0250 MT	25.00	3,700	6,500	24	1.46	249.0	28.1	1,860	210	2,657	300	5,315	600
P522S_0250 MTC	25.00	4,200	6,500	24	2.18	248.0	28.0	1,860	210	2,657	300	5,315	600
P522S_0250 MTL	25.00	3,700	6,500	32	3.68	249.0	28.1	1,860	210	2,657	300	5,315	600
P522S_0280 MT	28.00	4,000	7,000	24	1.34	237.2	26.8	1,860	210	2,657	300	4,915	555
P522S_0280 MTC	28.00	4,500	7,000	24	2.08	236.5	26.7	1,860	210	2,657	300	4,915	555
P522S_0280 MTL	28.00	4,000	7,000	32	3.60	237.2	26.8	1,860	210	2,657	300	4,915	555
P522S_0320 MT	32.00	3,300	6,000	24	1.54	222.8	25.1	1,772	200	2,215	250	4,429	500
P522S_0320 MTC	32.00	3,800	6,000	24	2.27	222.3	25.1	1,772	200	2,215	250	4,429	500
P522S_0320 MTL	32.00	3,300	6,000	32	3.76	222.8	25.1	1,772	200	2,215	250	4,429	500
P522S_0350 MT	35.00	4,000	7,000	24	1.33	245.3	27.7	1,860	210	2,657	300	5,315	600
P522S_0350 MTC	35.00	4,500	7,000	24	2.07	244.8	27.6	1,860	210	2,657	300	5,315	600
P522S_0350 MTL	35.00	4,000	7,000	32	3.59	245.3	27.7	1,860	210	2,657	300	5,315	600
P522S_0400 MT	40.00	4,000	7,000	24	1.28	232.5	26.2	1,860	210	2,657	300	4,915	555
P522S_0400 MTC	40.00	4,500	7,000	24	2.03	232.2	26.2	1,860	210	2,657	300	4,915	555
P522S_0400 MTL	40.00	4,000	7,000	32	3.55	232.5	26.2	1,860	210	2,657	300	4,915	555
P522S_0500 MT	50.00	4,000	7,000	24	1.28	242.0	27.3	1,860	210	2,657	300	5,315	600
P522S_0500 MTC	50.00	4,500	7,000	24	2.02	241.8	27.3	1,860	210	2,657	300	5,315	600
P522S_0500 MTL	50.00	4,000	7,000	32	3.54	242.0	27.3	1,860	210	2,657	300	5,315	600

Index of Symbols: **MT** — Motor adapter with TriAdapt® coupling; **MF** — Motor adapter with FlexiAdapt® coupling; **L** — Large Input; **C** — ServoCool

See Page 6 for Options and Part Number Configuration.



"P" Series ServoFit® Precision Planetary Gearhead Selection Data



Part Number (Gearhead + Input)	Exact Ratio i	Maximum Input Speed		Maximum Motor Shaft øD ⁶ mm	Input ¹⁾ Inertia J ₁ kgcm ²	Torsional Stiffness per arcmin C ₂		Output Torque					
		Continuous RPM (n ₁)	Cyclic RPM (n ₂)			Nominal ²⁾		Acceleration		Peak ³⁾			
						M _{2N}	M _{2B}	M _{2N}	M _{2B}	M _{2PEAK}	M _{2PEAK}		
Gearhead						in.lbs.	Nm	in.lbs.	Nm	in.lbs.	Nm	in.lbs.	Nm

P522 with Motor Mounting Plate *Continued*

P522S_0700 MT	70.00	4,000	7,000	24	1.27	233.2	26.3	1,860	210	2,392	270	5,315	600
P522S_0700 MTC	70.00	4,500	7,000	24	2.02	233.1	26.3	1,860	210	2,392	270	5,315	600
P522S_0700 MTL	70.00	4,000	7,000	32	3.54	233.2	26.3	1,860	210	2,392	270	5,315	600
P522S_1000 MT	100.0	4,000	7,000	24	1.27	215.5	24.3	1,240	140	2,215	250	4,429	500
P522S_1000 MTC	100.0	4,500	7,000	24	2.02	215.4	24.3	1,240	140	2,215	250	4,429	500
P522S_1000 MTL	100.0	4,000	7,000	32	3.54	215.5	24.3	1,240	140	2,215	250	4,429	500

P721 with Motor Mounting Plate

P721S_0030 MT	3.000	2,200	3,700	38	14.81	571.3	64.5	2,480	280	4,429	500	9,177	1,036
P721S_0030 MTC	3.000	3,000	6,000	38	26.04	484.5	54.7	2,480	280	4,429	500	9,177	1,036
P721S_0030 MTL	3.000	2,200	3,700	48	32.66	571.3	64.5	2,480	280	4,429	500	9,177	1,036
P721S_0040 MT	4.000	2,500	4,500	38	10.09	531.5	60.0	3,898	440	6,201	700	12,235	1,381
P721S_0040 MTC	4.000	3,300	6,000	38	21.33	485.9	54.9	3,898	440	6,201	700	12,235	1,381
P721S_0040 MTL	4.000	2,500	4,500	48	27.94	531.5	60.0	3,898	440	6,201	700	12,235	1,381
P721S_0050 MT	5.000	3,000	5,500	38	8.55	509.3	57.5	3,898	440	6,201	700	12,401	1,400
P721S_0050 MTC	5.000	3,800	6,000	38	19.79	481.6	54.4	3,898	440	6,201	700	12,401	1,400
P721S_0050 MTL	5.000	3,000	5,500	48	26.40	509.3	57.5	3,898	440	6,201	700	12,401	1,400
P721S_0070 MT	7.000	3,300	6,000	38	7.55	487.2	55.0	3,898	440	5,758	650	11,127	1,256
P721S_0070 MTC	7.000	4,500	6,000	38	18.46	470.7	53.1	3,898	440	5,758	650	11,127	1,256
P721S_0070 MTL	7.000	3,300	6,000	48	25.86	487.2	55.0	3,898	440	5,758	650	11,127	1,256
P721S_0080 MT	8.000	3,300	6,000	38	7.29	469.5	53.0	3,543	400	4,429	500	8,858	1,000
P721S_0080 MTC	8.000	5,000	6,000	38	18.20	457.6	51.7	3,543	400	4,429	500	8,858	1,000
P721S_0080 MTL	8.000	3,300	6,000	48	25.60	469.5	53.0	3,543	400	4,429	500	8,858	1,000
P721S_0100 MT	10.00	3,300	6,000	38	7.05	438.5	49.5	2,657	300	4,429	500	8,858	1,000
P721S_0100 MTC	10.00	5,000	6,000	38	17.95	431.8	48.7	2,657	300	4,429	500	8,858	1,000
P721S_0100 MTL	10.00	3,300	6,000	48	25.35	438.5	49.5	2,657	300	4,429	500	8,858	1,000

P722 with Motor Mounting Plate *Continued Next Page*

P722S_0150 MT	15.00	3,000	5,000	32	3.04	470.4	53.1	2,478	280	4,429	500	9,168	1,036
P722S_0150 MTC	15.00	4,000	6,000	32	5.56	470.4	53.1	2,478	280	4,429	500	9,168	1,036
P722S_0150 MTL	15.00	3,000	5,000	38	6.76	470.4	53.1	2,478	280	4,429	500	9,168	1,036
P722S_0160 MT	16.00	3,000	5,000	32	4.63	475.9	53.7	3,898	440	6,201	700	12,235	1,381
P722S_0160 MTC	16.00	4,000	6,000	32	6.85	470.4	53.1	3,898	440	6,201	700	11,868	1,340
P722S_0160 MTL	16.00	3,000	5,000	38	7.66	475.9	53.7	3,898	440	6,201	700	12,235	1,381
P722S_0200 MT	20.00	3,000	5,000	32	4.54	475.3	53.7	3,898	440	6,201	700	12,401	1,400
P722S_0200 MTC	20.00	4,000	6,000	32	6.76	471.8	53.3	3,898	440	6,201	700	12,401	1,400
P722S_0200 MTL	20.00	3,000	5,000	38	7.57	475.3	53.7	3,898	440	6,201	700	12,401	1,400
P722S_0250 MT	25.00	3,500	6,000	32	4.14	474.3	53.5	3,898	440	6,201	700	12,401	1,400
P722S_0250 MTC	25.00	4,500	6,000	32	6.36	472.0	53.3	3,898	440	6,201	700	12,401	1,400
P722S_0250 MTL	25.00	3,500	6,000	38	7.17	474.3	53.5	3,898	440	6,201	700	12,401	1,400
P722S_0280 MT	28.00	3,700	6,500	32	3.83	468.7	52.9	3,898	440	6,201	700	12,235	1,381
P722S_0280 MTC	28.00	4,500	6,500	32	6.07	466.9	52.7	3,898	440	6,201	700	12,235	1,381
P722S_0280 MTL	28.00	3,700	6,500	38	6.88	468.7	52.9	3,898	440	6,201	700	12,235	1,381
P722S_0320 MT	32.00	3,000	5,000	32	4.46	457.7	51.7	3,543	400	4,429	500	8,858	1,000
P722S_0320 MTC	32.00	4,000	5,000	32	6.68	456.4	51.5	3,543	400	4,429	500	8,858	1,000
P722S_0320 MTL	32.00	3,000	5,000	38	7.49	457.7	51.7	3,543	400	4,429	500	8,858	1,000

¹⁾ Inertia based on maximum input. For lower inertia using smaller diameter input, contact STOBER.

²⁾ Based on input speed: n₁ = 2000 RPM

For torque at higher input speeds (M_{2NX}) solve the formula, where n₁ = Actual Input Speed.
$$M_{2NX} = \frac{M_{2N}}{\sqrt[3]{\frac{n_1}{2000}}}$$

³⁾ Maximum momentary torque for emergency stops or heavy shock load. Admissible stops per life of gearhead = 1,000 stops maximum.



"P" Series ServoFit® Precision Planetary Gearhead Selection Data



P

Part Number (Gearhead + Input)	Exact Ratio i	Maximum Input Speed		Maximum Motor Shaft øD ⁶ mm	Input ¹⁾ Inertia J ₁ kgcm ²	Torsional Stiffness per arcmin		Output Torque					
		Continuous RPM (n ₁)	Cyclic			C ₂	Nominal ²⁾		Acceleration		Peak ³⁾		
							M _{2N}	M _{2B}	M _{2PEAK}	M _{2PEAK}			
Gearhead					in.lbs.	Nm	in.lbs.	Nm	in.lbs.	Nm	in.lbs.	Nm	

P722 with Motor Mounting Plate *Continued*

P722S_0350 MT	35.00	3,700	6,500	32	3.80	470.7	53.1	3,898	440	6,201	700	12,401	1,400
P722S_0350 MTC	35.00	4,500	6,500	32	6.04	469.5	53.0	3,898	440	6,201	700	12,401	1,400
P722S_0350 MTL	35.00	3,700	6,500	38	6.85	470.7	53.1	3,898	440	6,201	700	12,401	1,400
P722S_0400 MT	40.00	3,700	6,500	32	3.65	462.2	52.2	3,898	440	6,201	700	12,235	1,381
P722S_0400 MTC	40.00	5,000	6,500	32	5.90	461.3	52.1	3,898	440	6,201	700	12,235	1,381
P722S_0400 MTL	40.00	3,700	6,500	38	6.70	462.2	52.2	3,898	440	6,201	700	12,235	1,381
P722S_0500 MT	50.00	3,700	6,500	32	3.64	466.4	52.7	3,898	440	6,201	700	12,401	1,400
P722S_0500 MTC	50.00	5,000	6,500	32	5.88	465.9	52.6	3,898	440	6,201	700	12,401	1,400
P722S_0500 MTL	50.00	3,700	6,500	38	6.69	466.4	52.7	3,898	440	6,201	700	12,401	1,400
P722S_0700 MT	70.00	3,700	6,500	32	3.63	466.3	52.6	3,898	440	5,758	650	11,127	1,256
P722S_0700 MTC	70.00	5,000	6,500	32	5.87	466.0	52.6	3,898	440	5,758	650	11,127	1,256
P722S_0700 MTL	70.00	3,700	6,500	38	6.68	466.3	52.6	3,898	440	5,758	650	11,127	1,256
P722S_1000 MT	100.0	3,700	6,500	32	3.62	430.0	48.5	2,657	300	4,429	500	8,858	1,000
P722S_1000 MTC	100.0	5,000	6,500	32	5.86	429.8	48.5	2,657	300	4,429	500	8,858	1,000
P722S_1000 MTL	100.0	3,700	6,500	38	6.67	430.0	48.5	2,657	300	4,429	500	8,858	1,000

P821 with Motor Mounting Plate

P821S_0030 MT	3.000	1,800	3,000	48	65.03	1,948.8	220.0	7,086	800	10,630	1,200	17,064	1,926
P821S_0030 MTC	3.000	2,500	4,500	48	86.28	1,464.9	165.4	7,086	800	10,630	1,200	15,518	1,752
P821S_0030 MTL	3.000	1,800	3,000	60	92.59	1,787.0	201.7	7,086	800	10,630	1,200	17,064	1,926
P821S_0040 MT	4.000	2,200	3,500	48	41.18	1,815.9	205.0	7,086	800	14,173	1,600	22,752	2,569
P821S_0040 MTC	4.000	3,000	5,000	48	62.44	1,547.9	174.7	7,086	800	14,173	1,600	20,690	2,336
P821S_0040 MTL	4.000	2,200	3,500	60	68.75	1,733.6	195.7	7,086	800	14,173	1,600	22,752	2,569
P821S_0050 MT	5.000	2,500	4,000	48	34.36	1,718.5	194.0	8,858	1,000	14,173	1,600	28,346	3,200
P821S_0050 MTC	5.000	3,500	6,000	48	55.62	1,555.4	175.6	8,858	1,000	14,173	1,600	25,863	2,920
P821S_0050 MTL	5.000	2,500	4,000	60	57.31	1,670.4	188.6	8,858	1,000	14,173	1,600	28,346	3,200
P821S_0070 MT	7.000	2,800	4,500	48	29.23	1,563.4	176.5	8,858	1,000	12,401	1,400	24,900	2,811
P821S_0070 MTC	7.000	4,000	6,000	48	50.96	1,478.9	167.0	8,858	1,000	12,401	1,400	24,900	2,811
P821S_0070 MTL	7.000	2,800	4,500	60	57.24	1,542.9	174.2	8,858	1,000	12,401	1,400	24,900	2,811
P821S_0080 MT	8.000	2,800	4,500	48	27.99	1,472.2	166.2	7,086	800	10,630	1,200	21,259	2,400
P821S_0080 MTC	8.000	4,500	6,000	48	49.72	1,413.9	159.6	7,086	800	10,630	1,200	21,259	2,400
P821S_0080 MTL	8.000	2,800	4,500	60	56.00	1,458.2	164.6	7,086	800	10,630	1,200	21,259	2,400
P821S_0100 MT	10.00	2,800	4,500	48	26.82	1,355.3	153.0	6,201	700	10,630	1,200	21,259	2,400
P821S_0100 MTC	10.00	4,500	6,000	48	48.55	1,323.1	149.4	6,201	700	10,630	1,200	21,259	2,400
P821S_0100 MTL	10.00	2,800	4,500	60	54.84	1,347.6	152.1	6,201	700	10,630	1,200	21,259	2,400

P822 with Motor Mounting Plate *Continued Next Page*

P822S_0150 MT	15.00	2,500	4,500	38	8.65	1,470.7	166.2	7,086	800	10,620	1,200	17,049	1,926
P822S_0150 MTC	15.00	3,300	6,000	38	11.85	1,470.7	166.2	7,086	800	10,620	1,200	17,049	1,926
P822S_0150 MTL	15.00	2,500	4,500	48	26.63	1,470.7	166.2	7,086	800	10,620	1,200	17,049	1,926
P822S_0160 MT	16.00	2,500	4,500	38	10.65	1,496.4	168.9	7,086	800	14,173	1,600	28,346	3,200
P822S_0160 MTC	16.00	3,300	6,000	38	21.89	1,472.1	166.2	7,086	800	14,173	1,600	28,346	3,200
P822S_0160 MTL	16.00	2,500	4,500	48	28.50	1,496.4	168.9	7,086	800	14,173	1,600	28,346	3,200
P822S_0200 MT	20.00	2,500	4,500	38	10.22	1,521.7	171.8	8,858	1,000	14,173	1,600	28,346	3,200
P822S_0200 MTC	20.00	3,300	6,000	38	21.46	1,505.5	170.0	8,858	1,000	14,173	1,600	28,346	3,200
P822S_0200 MTL	20.00	2,500	4,500	48	28.07	1,521.7	171.8	8,858	1,000	14,173	1,600	28,346	3,200

Index of Symbols: **MT** — Motor adapter with TriAdapt® coupling; **MF** — Motor adapter with FlexiAdapt® coupling; **L** — Large Input; **C** — ServoCool

See Page 6 for Options and Part Number Configuration.



"P" Series ServoFit® Precision Planetary Gearhead Selection Data



Part Number (Gearhead + Input)	Exact Ratio i	Maximum Input Speed		Maximum Motor Shaft øD ⁶ mm	Input ¹⁾ Inertia J ₁ kgcm ²	Torsional Stiffness per arcmin		Output Torque					
		Continuous RPM (n ₁)	Cyclic			C ₂		Nominal ²⁾		Acceleration		Peak ³⁾	
						in.lbs.	Nm	M _{2N}	Nm	M _{2B}	Nm	M _{2PEAK}	Nm

P822 with Motor Mounting Plate *Continued*

P822S_0250 MT	25.00	3,000	5,500	38	8.83	1,514.1	170.9	8,858	1,000	14,173	1,600	28,346	3,200
P822S_0250 MTC	25.00	3,800	6,000	38	20.07	1,503.8	169.8	8,858	1,000	14,173	1,600	28,346	3,200
P822S_0250 MTL	25.00	3,000	5,500	48	26.68	1,514.1	170.9	8,858	1,000	14,173	1,600	28,346	3,200
P822S_0280 MT	28.00	3,300	6,000	38	7.81	1,472.8	166.3	7,086	800	14,173	1,600	28,346	3,200
P822S_0280 MTC	28.00	4,300	6,000	38	18.71	1,463.1	165.2	7,086	800	14,173	1,600	28,346	3,200
P822S_0280 MTL	28.00	3,300	6,000	48	26.11	1,472.8	166.3	7,086	800	14,173	1,600	28,346	3,200
P822S_0320 MT	32.00	2,500	4,500	38	9.85	1,411.1	159.3	7,086	800	10,630	1,200	21,259	2,400
P822S_0320 MTC	32.00	3,300	6,000	38	21.09	1,405.7	158.7	7,086	800	10,630	1,200	21,259	2,400
P822S_0320 MTL	32.00	2,500	4,500	48	27.70	1,411.1	159.3	7,086	800	10,630	1,200	21,259	2,400
P822S_0350 MT	35.00	3,300	6,000	38	7.67	1,506.0	170.0	8,858	1,000	14,173	1,600	28,346	3,200
P822S_0350 MTC	35.00	4,300	6,000	38	18.58	1,499.5	169.3	8,858	1,000	14,173	1,600	28,346	3,200
P822S_0350 MTL	35.00	3,300	6,000	48	25.97	1,506.0	170.0	8,858	1,000	14,173	1,600	28,346	3,200
P822S_0400 MT	40.00	3,300	6,000	38	7.17	1,442.5	162.8	7,086	800	14,173	1,600	28,346	3,200
P822S_0400 MTC	40.00	4,500	6,000	38	18.08	1,437.9	162.3	7,086	800	14,173	1,600	28,346	3,200
P822S_0400 MTL	40.00	3,300	6,000	48	25.47	1,442.5	162.8	7,086	800	14,173	1,600	28,346	3,200
P822S_0500 MT	50.00	3,300	6,000	38	7.10	1,485.6	167.7	8,858	1,000	14,173	1,600	28,346	3,200
P822S_0500 MTC	50.00	4,500	6,000	38	18.01	1,482.5	167.4	8,858	1,000	14,173	1,600	28,346	3,200
P822S_0500 MTL	50.00	3,300	6,000	48	25.40	1,485.6	167.7	8,858	1,000	14,173	1,600	28,346	3,200
P822S_0700 MT	70.00	3,300	6,000	38	7.06	1,457.4	164.5	8,858	1,000	12,401	1,400	24,900	2,811
P822S_0700 MTC	70.00	4,500	6,000	38	17.96	1,455.9	164.4	8,858	1,000	12,401	1,400	24,900	2,811
P822S_0700 MTL	70.00	3,300	6,000	48	25.36	1,457.4	164.5	8,858	1,000	12,401	1,400	24,900	2,811
P822S_1000 MT	100.0	3,300	6,000	38	7.03	1,314.6	148.4	6,201	700	10,630	1,200	21,259	2,400
P822S_1000 MTC	100.0	4,500	6,000	38	17.94	1,314.0	148.3	6,201	700	10,630	1,200	21,259	2,400
P822S_1000 MTL	100.0	3,300	6,000	48	25.33	1,314.6	148.4	6,201	700	10,630	1,200	21,259	2,400

¹⁾ Inertia based on maximum input. For lower inertia using smaller diameter input, contact STOBER.

²⁾ Based on input speed: n₁ = 2000 RPM

For torque at higher input speeds (M_{2NX}) solve the formula, where n₁ = Actual Input Speed.
$$M_{2NX} = \frac{M_{2N}}{\sqrt[3]{\frac{n_1}{2000}}}$$

³⁾ Maximum momentary torque for emergency stops or heavy shock load. Admissible stops per life of gearhead = 1,000 stops maximum.



"P" Series ServoFit® Precision Planetary Gearhead Selection Data



P

Part Number (Gearhead + Input)	Exact Ratio i	Maximum Input Speed		Maximum Motor Shaft øD ⁶ mm	Input ¹⁾ Inertia J ₁ kgcm ²	Torsional Stiffness per arcmin C ₂		Output Torque					
		Continuous RPM (n _i)	Cyclic			in.lbs.	Nm	Nominal ²⁾		Acceleration		Peak ³⁾	
								M _{2N}	M _{2B}	M _{2PEAK}	M _{2PEAK}		

P921 with Motor Mounting Plate

P921S_0040 MT	4.000	2,000	3,000	60	98.17	3,093.9	349.3	17,716	2,000	26,574	3,000	48,117	5,432
P921S_0040 MTC	4.000	3,000	4,500	60	105.81	3,093.9	349.3	17,716	2,000	26,574	3,000	51,554	5,820
P921S_0050 MT	5.000	2,200	3,500	60	80.39	3,027.4	341.8	17,716	2,000	26,574	3,000	53,148	6,000
P921S_0050 MTC	5.000	3,500	5,000	60	88.03	3,027.4	341.8	17,716	2,000	26,574	3,000	53,148	6,000
P921S_0070 MT	7.000	2,500	4,000	60	67.08	2,852.0	322.0	17,716	2,000	23,917	2,700	47,833	5,400
P921S_0070 MTC	7.000	4,000	5,000	60	74.72	2,852.0	322.0	17,716	2,000	23,917	2,700	47,833	5,400
P921S_0100 MT	10.00	2,500	4,000	60	59.46	2,281.1	257.5	12,401	1,400	17,716	2,000	35,432	4,000
P921S_0100 MTC	10.00	4,000	5,000	60	67.09	2,281.1	257.5	12,401	1,400	17,716	2,000	35,432	4,000

P922 with Motor Mounting Plate

P922S_0160 MT	16.00	2,200	3,500	48	42.16	3,016.6	340.5	17,716	2,000	26,574	3,000	53,148	6,000
P922S_0160 MTC	16.00	3,000	5,000	48	63.41	2,963.3	334.5	17,716	2,000	26,574	3,000	53,148	6,000
P922S_0160 MTL	16.00	2,200	3,500	60	69.72	3,001.8	338.9	17,716	2,000	26,574	3,000	53,148	6,000
P922S_0200 MT	20.00	2,200	3,500	48	41.04	2,979.6	336.4	17,716	2,000	26,574	3,000	53,148	6,000
P922S_0200 MTC	20.00	3,000	5,000	48	62.30	2,946.1	332.6	17,716	2,000	26,574	3,000	53,148	6,000
P922S_0200 MTL	20.00	2,200	3,500	60	68.61	2,970.3	335.3	17,716	2,000	26,574	3,000	53,148	6,000
P922S_0250 MT	25.00	2,500	4,000	48	34.78	2,968.5	335.1	17,716	2,000	26,574	3,000	53,148	6,000
P922S_0250 MTC	25.00	3,500	6,000	48	56.04	2,947.2	332.7	17,716	2,000	26,574	3,000	53,148	6,000
P922S_0250 MTL	25.00	2,500	4,000	60	62.35	2,962.7	334.5	17,716	2,000	26,574	3,000	53,148	6,000
P922S_0280 MT	28.00	2,800	4,500	48	29.81	2,966.8	334.9	17,716	2,000	26,574	3,000	53,148	6,000
P922S_0280 MTC	28.00	3,750	5,000	48	51.54	2,946.8	332.7	17,716	2,000	26,574	3,000	53,148	6,000
P922S_0280 MTL	28.00	2,800	4,500	60	57.82	2,962.1	334.4	17,716	2,000	26,574	3,000	53,148	6,000
P922S_0350 MT	35.00	2,800	4,500	48	29.45	2,948.3	332.8	17,716	2,000	26,574	3,000	53,148	6,000
P922S_0350 MTC	35.00	3,750	6,000	48	51.18	2,935.7	331.4	17,716	2,000	26,574	3,000	53,148	6,000
P922S_0350 MTL	35.00	2,800	4,500	60	57.46	2,945.4	332.5	17,716	2,000	26,574	3,000	53,148	6,000
P922S_0400 MT	40.00	2,800	4,500	48	26.78	2,913.7	328.9	17,716	2,000	26,574	3,000	53,148	6,000
P922S_0400 MTC	40.00	4,000	6,000	48	48.51	2,904.3	327.9	17,716	2,000	26,574	3,000	53,148	6,000
P922S_0400 MTL	40.00	2,800	4,500	60	54.79	2,911.5	328.7	17,716	2,000	26,574	3,000	53,148	6,000
P922S_0500 MT	50.00	2,800	4,500	48	26.60	2,914.6	329.0	17,716	2,000	26,574	3,000	53,148	6,000
P922S_0500 MTC	50.00	4,000	6,000	48	48.33	2,908.5	328.3	17,716	2,000	26,574	3,000	53,148	6,000
P922S_0500 MTL	50.00	2,800	4,500	60	54.61	2,913.1	328.9	17,716	2,000	26,574	3,000	53,148	6,000
P922S_0700 MT	70.00	2,800	4,500	48	26.47	2,799.9	316.1	17,716	2,000	23,917	2,700	47,833	5,400
P922S_0700 MTC	70.00	4,000	6,000	48	48.20	2,797.0	315.8	17,716	2,000	23,917	2,700	47,833	5,400
P922S_0700 MTL	70.00	2,800	4,500	60	54.48	2,799.2	316.0	17,716	2,000	23,917	2,700	47,833	5,400
P922S_1000 MT	100.0	2,800	4,500	48	26.39	2,264.6	255.7	12,401	1,400	17,716	2,000	35,432	4,000
P922S_1000 MTC	100.0	4,000	6,000	48	48.12	2,263.7	255.6	12,401	1,400	17,716	2,000	35,432	4,000
P922S_1000 MTL	100.0	2,800	4,500	60	54.40	2,264.4	255.6	12,401	1,400	17,716	2,000	35,432	4,000

Index of Symbols: **MT** — Motor adapter with TriAdapt® coupling; **MF** — Motor adapter with FlexiAdapt® coupling; **L** — Large Input; **C** — ServoCool

See Page 6 for Options and Part Number Configuration.



"P" Series ServoFit® Precision Planetary Gearhead Dimensional Data

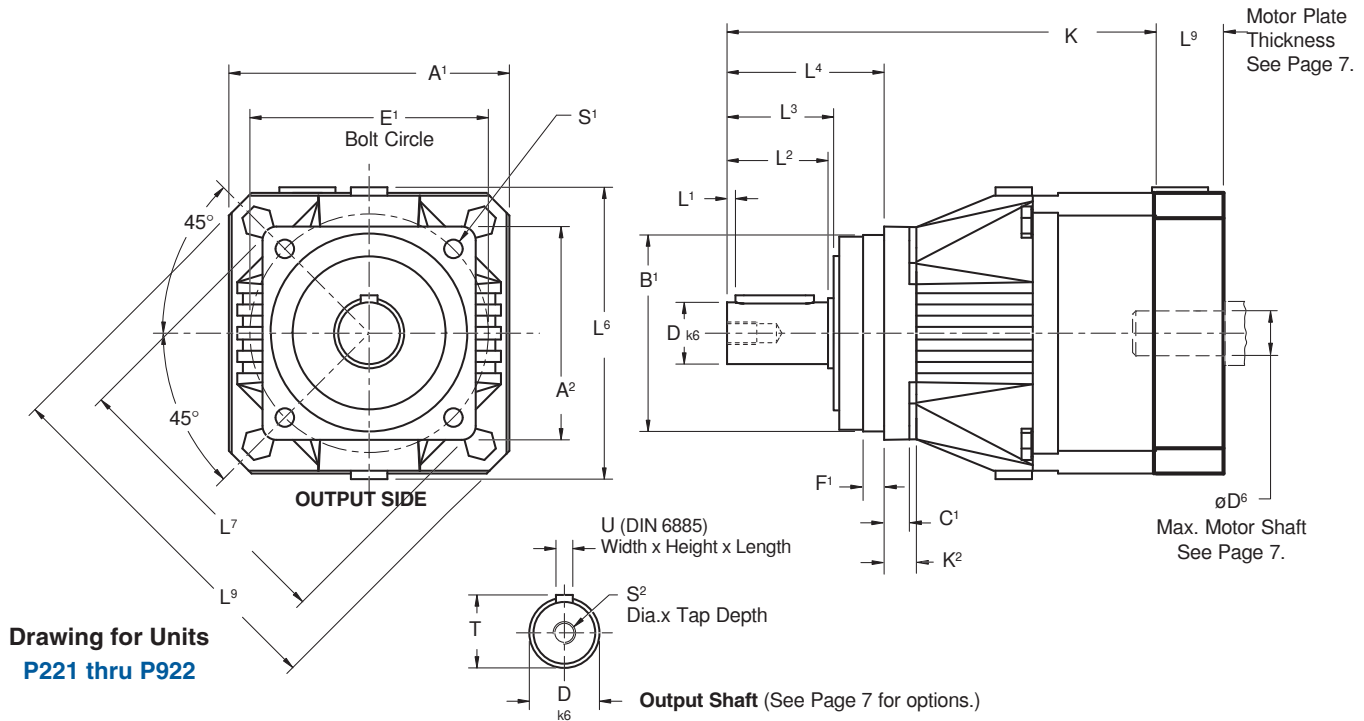

**Drawing for Units
P221 thru P922**

Table No. 1 "P" Series – Precision Planetary Gearhead Dimensions (mm)

Unit	A ¹	A ²	B ¹	h ₆	C ¹	D _{k6}	E ¹	F ¹	K ²	L ¹	L ²	L ³	L ⁴	L ⁶	L ⁷	L ⁸	S ¹	S ²	T	U
P221/P222	55	55	50	+0.00/-0.019	6	12 +0.012/+0.001	63	7	—	2	22	24	36	62	74	80	5.5	M4x10	13.5	A4x4x18
P321/P322	72	72	60	+0.00/-0.019	7	16 +0.012/+0.001	75	7.5	—	2	28	30	48	79	92	92	5.5	M5x12.5	18	A5x5x22
P421/P422	98	76	70	+0.00/-0.019	9	22 +0.015/+0.002	85	7.5	12	3	36	38	56	98	103.3	130	6.6	M8x19	24.5	A6x6x28
P521/P522	115	101	90	+0.00/-0.022	10	32 +0.018/+0.002	120	15	14	3	58	60	88	121	139	149	9	M12x28	35	A10x8x50
P721/P722	145	145	130	+0.00/-0.025	15	40 +0.018/+0.002	165	3.5	—	4	82	85	112	145	—	190	11	M16x36	43	A12x8x70
P821/P822	190	190	160	+0.00/-0.025	15	55 +0.021/+0.002	215	10	—	6	82	85	112	190	—	250	13.5	M20x42	59	A16x10x70
P921/P922	225	212	180	+0.00/-0.025	17	75 +0.021/+0.002	250	10	22	7	105	109	143	225	285	300	17.5	M20x42	79.5	A20x12x90

Table No. 2

	K Dimension (mm)		
	Standard	ServoCool	
P221	94.5	—	—
P222	126.5	—	—
P321	135	—	—
P322	158.5	—	—
P421	153	P421_C	176.5
P422	200.5	—	—
P521	193	P521_C	221
P522	242.5	P522_C	266
P721	242	P721_C	272
P722	294	P722_C	322
P821	283	P821_C	331
P822	350.5	P822_C	380.5
P921	353	P921_C	418
P922	441	P922_C	489

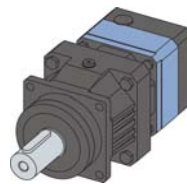

Typical 2 Stage Configuration

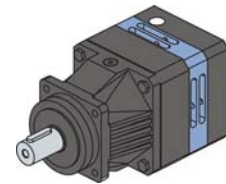

Typical ServoCool Configuration

Part No. Example
P421SPR0030MTC



"P" Series – Large Input ServoFit® Precision Planetary Gearhead Dimensional Data



P

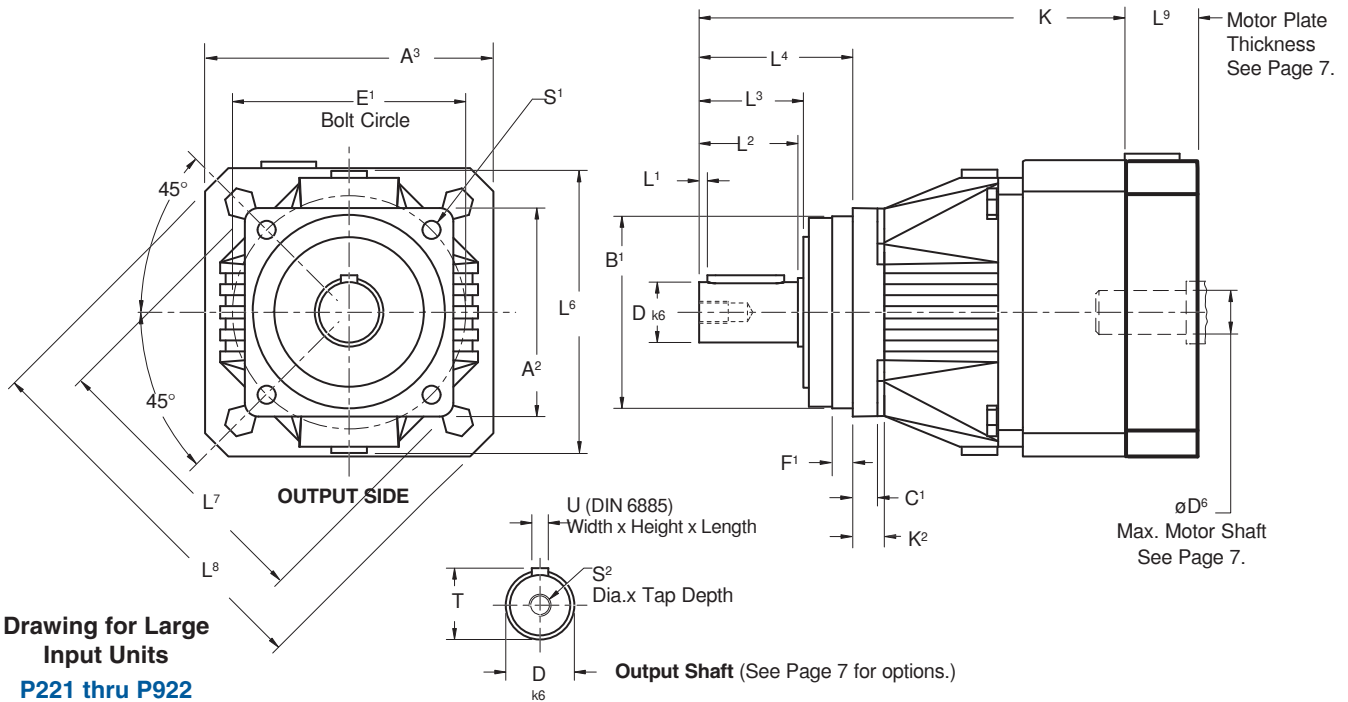

Table No. 1 "P" Series – Large Input – Precision Planetary Gearhead Dimensions (mm)

Unit	A ²	B ¹ h6	C ¹	D k6	E ¹	F ¹	K ²	L ¹	L ²	L ³	L ⁴	L ⁶	L ⁷	S ¹	S ²	T	U
P221/P222_L	55	50 +0.000/-0.019	6	12 +0.012/+0.001	63	7	—	2	22	24	36	92	74	5.5	M4x10	13.5	A4x4x18
P321/P322_L	72	60 +0.000/-0.019	7	16 +0.012/+0.001	75	7.5	—	2	28	30	48	130	92	5.5	M5x12.5	18	A5x5x22
P421/P422_L	76	70 +0.000/-0.019	9	22 +0.015/+0.002	85	7.5	12	3	36	38	56	149	103.3	6.6	M8x19	24.5	A6x6x28
P521/P522_L	101	90 +0.000/-0.022	10	32 +0.018/+0.002	120	15	14	3	58	60	88	190	139	9	M12x28	35	A10x8x50
P721/P722_L	145	130 +0.000/-0.025	15	40 +0.018/+0.002	165	3.5	—	4	82	85	112	250	—	11	M16x36	43	A12x8x70
P821/P822_L	190	160 +0.000/-0.025	15	55 +0.021/+0.002	215	10	—	6	82	85	112	190	—	13.5	M20x42	59	A16x10x70
P922_L	212	180 +0.000/-0.025	17	75 +0.021/+0.002	250	10	22	7	105	109	143	225	285	17.5	M20x42	79.5	A20x12x90



Typical 2 Stage Configuration
Large Input

Part No. Example
P421SPR0030MTL

Table No. 2

Unit	A ³	K	L ⁸
P221_L	75	111	100
P222_L	75	143	100
P321_L	100	138.3	130
P322_L	75	175	100
P421_L	115	161.5	149
P422_L	100	203.8	130
P521_L	145	207	190
P522_L	115	251	149
P721_L	190	259	250
P722_L	145	308	190
P821_L	225	291	300
P822_L	190	367.5	250
P922_L	225	449	300

See Page 6 for Options and Part Number Configuration.

"PA" Series – Advanced ServoFit® Precision Planetary Gearhead Performance Specification Overview



			PA321 PA322	PA421 PA422	PA521 PA522	PA721 PA722	PA821 PA822
Acceleration Torque Maximum	M _{2B}	in.lbs. Nm	575 65	1052 120	2,655 300	6,195 700	14,160 1,600
Nominal Output Torque ¹⁾	M _{2N}	in.lbs. Nm	399 45	753 85	1,860 210	3,898 440	8,858 1,000
Input Speed Maximum	n _{1MAX}	Continuous Cyclic	4,500 8,000	4,000 4,500 7,000 8,000	3,700 4,000 6,500 7,000	3,300 3,700 6,000 6,500	2,800 3,300 4,500 6,000
ServoCool Input RPM Maximum	n _{1MAX}	Continuous Cyclic	— —	6,000 — 7,000 —	6,000 5,500 6,500 7,000	5,500 5,500 6,000 6,500	5,500 5,000 6,000 6,000
Torsional Backlash ²⁾	Δφ	arcmin	≤2 ≤3	≤2 ≤3	≤1 ≤2	≤1 ≤2	≤1 ≤2
Torsional Stiffness	C ₂	in.lbs./arcmin Nm/arcmin	44 5	100 11	266 33	486 55	1,557 176
Axial Load Max.	F _{2AMAX}	lbs. N	315 1,400	506 2,250	788 3,500	1,013 4,500	1,688 7,500
Radial Load Max. ³⁾	F _{2RMAX}	lbs. N	619 2,750	1,012 4,500	1,575 7,000	2,025 9,000	3,375 15,000
Tilting Moment Max. ³⁾	M _{2KMAX}	in.lbs. Nm	2,044 231	3,885 439	7,496 847	11,629 1,314	23,497 2,655
Efficiency (at Nominal Torque)	h	%	97% 95%	97% 95%	97% 95%	97% 95%	97% 95%
Weight	m	pounds kg	6 8 2.6 3.5	9 12 4.0 5.3	14 19 6.5 8.5	27 33 12 15	57 71 26 32
Noise Level	L _{PA}	dB(A) ⁴⁾	≤61 ≤61	≤62 ≤60	≤63 ≤61	≤64 ≤62	≤65 ≤63
Balance Quality	Q 2.5 (Quality Class-2.5 millimeters per second)						
Lubrication	Synthetic Oil — Lubricated for Life						
Degree of Protection	IP65 - FKM Shaft Seals						
Mounting Position	Unrestricted						
Direction of Rotation	Input and Output Rotate the SAME Direction.						
Ambient Temperature	0° C to +40°C (104° F) [Unit temperature ≤ 90° C Max.]						
Finish	Black (Standard), Washdown, Food and Beverage Options Available						
Lifetime.⁵⁾	L _h	hours	L _h > 10,000 hours if M _{2K} /M _{2A} < 1.25 and > 1.00 L _h > 20,000 hours if M _{2K} /M _{2A} > 1.25 and < 1.50 L _h > 30,000 hours if M _{2K} /M _{2A} > 1.5				
Warranty	5 Year Limited (2 Years on normal wear items: bearings, seals, etc.)						

¹⁾ Ratings based on input speed (n₁) of 2000 RPM.

For torque at higher input speeds (M_{2NX}) solve the formula, where n₁ = Actual Input Speed.
$$M_{2NX} = \frac{M_{2N}}{\sqrt[3]{\frac{n_1}{2000}}}$$

²⁾ Tested at 1.5% of nominal torque and recorded on the output side of the gearhead.

³⁾ Rating based on output speed (n₂) of 100 RPM. For values at other speeds see Page 24.

⁴⁾ Measurement at one (1) meter distance with input speed (n₁) of 2000 RPM.

⁵⁾ M_{2A} equals actual tilting moment of the application. See Page 24 for calculation details.

WARNING: In order to insure that the specified torque ratings are attained, it is essential to attach the gear units to the machine with a grade 10.9 fastener.

Refer to Page 302 for ServoFit Precision Planetary Gearhead Selection Procedure.



"PA" Series – Advanced ServoFit® Precision Planetary Gearhead Features

The "PA" Series Advanced ServoFit Precision Planetary Gearheads feature HeliCamber® gearing, FlexiAdapt® motor adapter system and other features which make them the most accurate, efficient, and lowest backlash planetary gearheads available. HeliCamber® gear technology provides minimum wear, low backlash and low noise. All units are lubricated for life with synthetic oil and sealed to IP65 standards to prevent lubricant contamination.

- Some of these features are:
- Lowest Backlash on the Market
 - Advanced Gear Technology
 - Quiet Running
 - 5 Year Limited Warranty (2 years on bearings, seals, etc.)
 - Readily Attaches to Any Servo Motor (IEC, NEMA, or customized motor plates*)
 - High Torsional Stiffness
 - 95 to 97% Efficiency
 - Ground and honed gearing

* Maximum 10 working days for custom motor plates.

Backlash ≤ 1 arcminute — Precision selection of parts ensure optimal performance without binding gear teeth — resulting in a more accurate and smooth direct drive

Double row ball bearings on the output for high radial and axial capacity while maintaining efficiency.

Magnetic oil filtration

Motor plate pilot toleranced to fit your motor for precise concentricity

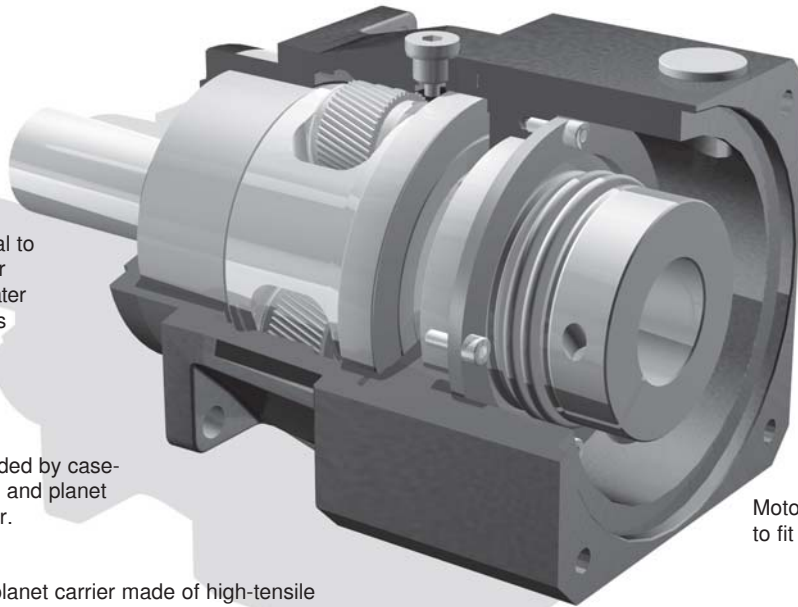

Ring gear machined integral to the housing — not welded or pressed in — provides greater concentricity and eliminates speed fluctuation

Adapter bushings to fit all motor shafts — no key required

High quality gearing provided by case-hardened and ground sun and planet gears and honed ring gear.

Motor plate can easily be changed to fit your choice of motors

Oversized single-piece planet carrier made of high-tensile material assure the highest torsional stiffness while straddle mounted bearings minimize misalignment.

FKM seals for the smallest possible diameter—reducing friction and heat buildup, increasing efficiency, and allowing continuous duty without additional cooling.

Highest running accuracy and precision ensured by single piece housing made from high-tensile tempered ductile iron with the additional characteristics of dissipating heat, noise dampening, and greater lubrication retention on the ring gear

The FlexiAdapt® motor coupling is designed for accurate and precise motor installation. The integrated thermal expansion feature in the shape of a bellows compensates for linear expansion of the motor shaft.

The FlexiAdapt® motor shaft adapter system allows installation of motor in minutes without special tools.





"PA" Series – Advanced ServoFit® Precision Planetary Gearhead



Part No. Explanation

PA **4** **2** **1** **S** **P** **D** **0030** **MF** **L**

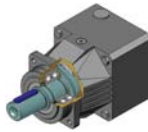
Series Size Generation No. of Gear Stages Housing Output Option Bearing Option Ratio Input Input Option

Series	PA	Advanced Planetary Gearhead (lowest backlash)
Size	4	3, 4 , 5, 7, 8
Generation	2	First generation 0, second generation 1 , etc.
No. of Gear Stages	1	1 , 2, (determined by the ratio)
Housing Style	S	Standard
Output Shaft	P	Shaft with Key 
	G	Plain Shaft (no key) 
Bearing Option	D	Reinforced Bearing (axial) 
Ratio	0030	Approximate: 0030 = 3.00:1 (range of 3:1 up to 100:1)
Motor Adapter	MF	FlexiAdapt® Motor Adapter <i>(Motor information must be specified.)</i>
Option	L	Large Input Option 
	C	ServoCool  (available in sizes PA421 thru PA822)



"PA" Series – Advanced ServoFit® Precision Planetary Gearhead

Motor Mounting Specifications

STOBER ServoFit Gearheads will fit the motor of your choice by assembling the correct motor mounting plate between the motor and the gearhead. **When ordering a gearhead, specify the motor manufacturer and part number, provide the motor drawing with dimensions, or specify the motor mounting dimensions.** The motor plate thickness (L^9) will be determined by the motor shaft length. The minimum motor plate thickness is shown below. For a precise dimension on a specific motor, contact STOBER Technical Support.

The following dimensions are required to provide the correct motor mounting plate:

1. D^6 Motor Shaft Diameter (If an adapter bushing is required it will be supplied with the motor plate.)
2. D^7 Pilot Diameter
3. D^8 Bolt Circle Diameter
4. D^9 Bolt Diameter
5. L^{11} Motor Shaft Length
6. L^{12} Pilot Length
7. L^{14} Square Flange (Optional — motor plate will typically be made to match this dimension.)

Table No. 1

Motor Plate Dims.	Planetary Size					
	PA322	PA321 PA422	PA321L PA421 PA422L PA522	PA421L PA521 PA522L PA722	PA521L PA721 PA722L PA822	PA721L PA821 PA822L
D^6 Max.	14	19	24	32	38	48
L^9 Min.	15	18	21	24	25	33

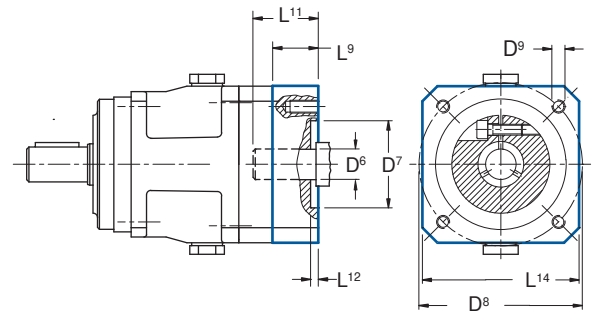

Output Shaft Options

The designation "P" or "G" for the output shaft must be included as part of the unit part number.

"P" – Shaft with Key

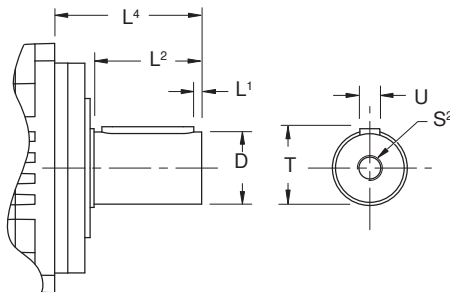

"G" – Shaft without Key

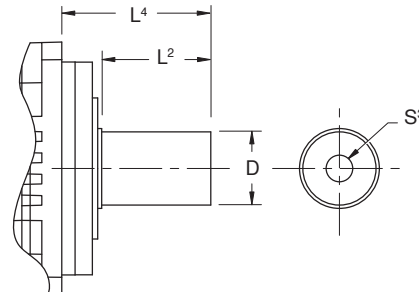

Table No. 1 Output Shaft Options

P – Shaft with Key									
Unit No.	D k6 mm	L^1 mm inches	L^2 mm inches	L^4 mm inches	S^2 (1)	T mm inches	U (2)	WDxHTxLG	
PA3	16 +.012/+0.001	2 .08	28 1.10	48 1.89	M5	18 .71	A5x5x22		
PA4	22 +.015/+0.002	3 .11	36 1.42	56 2.20	M8	24.5 .96	A6x6x28		
PA5	32 +.018/+0.002	3 .11	58 2.28	88 3.46	M12	35 1.38	A10x8x50		
PA7	40 +.018/+0.002	4 .16	82 3.23	112 4.41	M16	43 1.69	A12x8x70		
PA8	55 +.021/+0.002	6 .24	82 3.23	112 4.41	M20	59 2.32	A16x10x70		

G – Shaft without Key				
Unit No.	D k6 mm	L^2 mm inches	L^4 mm inches	S^3 (1)
PA3	16 +.012/+0.001	28 1.10	48 1.89	R4x8.5
PA4	22 +.015/+0.002	36 1.42	56 2.20	R4x8.5
PA5	32 +.018/+0.002	58 2.28	88 3.46	R4x8.5
PA7	40 +.018/+0.002	82 3.23	112 4.41	R4x8.5
PA8	55 +.021/+0.002	82 3.23	112 4.41	R5x10.6

(1) The center hole in shafts with keys (Option "P") are machined to DIN 332 T2 shape DR.

(2) Feather keys are toleranced according to standard DIN 6885.

"PA" Series – Advanced ServoFit® Precision Planetary Gearhead Shaft Loads



All formulas shown are based on METRIC values.

Upper case letters are permissible values. Lower case letters are for existing values.

The permissible load and tilting moment values are based on an output speed of 100 RPM. For higher speeds the following applies, where n_2 is the desired speed:

$$F_{2AX} = \frac{F_{2A}}{\sqrt[3]{\frac{n_2}{100}}} \quad F_{2RX} = \frac{F_{2R}}{\sqrt[3]{\frac{n_2}{100}}} \quad M_{2KX} = \frac{M_{2K}}{\sqrt[3]{\frac{n_2}{100}}}$$

The application input tilting moment should be determined by the following formula:

$$M_{2A} = \frac{2 \cdot F_{2a} \cdot y_2 + F_{2rb} \cdot (X_2 + Z_2)}{1000} \leq M_{2KB}$$

$$M_{2ka} = \sqrt[3]{\frac{n_{2b1} \cdot t_{b1} \cdot M_{2kb1}^3 + \dots + n_{2bn} \cdot t_{bn} \cdot M_{2kbn}^3}{n_{2b1} \cdot t_{b1} + \dots + n_{2bn} \cdot t_{bn}}} \leq M_{2K}$$

$$F_{2r} = \sqrt[3]{\frac{n_{2b1} \cdot t_{b1} \cdot F_{2rb1}^3 + \dots + n_{2bn} \cdot t_{bn} \cdot F_{2rbn}^3}{n_{2b1} \cdot t_{b1} + \dots + n_{2bn} \cdot t_{bn}}} \leq F_{2R}$$

- where:
- F_{2a} Axial Load at Output Shaft
 - F_{2A} Permissible Axial Load
 - F_{2r} Radial Load at Output Shaft
 - F_{2R} Permissible Radial Load
 - F_{2RB} Acceleration Permissible Radial Load
 - M_{2K} Rated Tilting Torque
 - M_{2k} Equivalent Tilting Load
 - M_{2KB} Acceleration Tilting Torque
 - Z_2 Distance Factor

The hours of life (L_h) of the unit can be determined by the following formula:

bearing life for duty cycle $\leq 40\%$

- $L_h > 10,000$ hours if $M_{2k}/M_{2A} < 1.25$ and > 1
- $L_h > 20,000$ hours if $M_{2k}/M_{2A} > 1.25$ and > 1.5
- $L_h > 30,000$ hours if $M_{2k}/M_{2A} < 1.5$

bearing life for duty cycle $\geq 40\%$

$$L_{hA} = L_h \left(\frac{40\%}{\text{Duty Cycle}} \right)$$

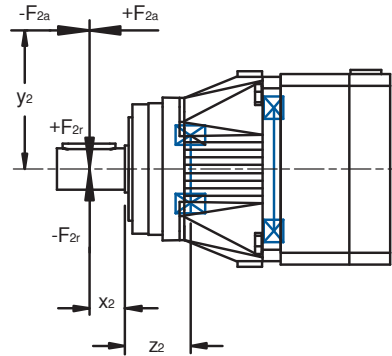

Table No. 1 Permissible Output Shaft Load and Tilting Moments

D – Output Bearing Option, Axially Reinforced

Unit No.	Z_2		F_{2A}		F_{2R}		F_{2RB}		M_{2K}		M_{2KB}	
	mm	inches	N	lbs.	N	lbs.	N	lbs.	Nm	in.lbs.	Nm	in.lbs.
PA3	24	.945	1,400	315	2,750	619	2,750	619	105	929	105	929
PA4	25	.984	2,250	506	4,500	1,013	5,000	1,125	194	1,717	215	1,903
PA5	29	1.142	3,500	788	7,000	1,575	8,000	1,800	406	3,593	464	4,106
PA7	31	1.220	4,500	1,013	9,000	2,025	10,000	2,250	648	5,735	720	6,372
PA8	35	1.378	7,500	1,688	15,000	3,375	18,000	4,050	1,140	10,089	1,368	12,107

During EMERGENCY OFF operation (maximum stops per gearhead = 1000) the permissible values in the table for F_{2A} , F_{2R} , and M_{2K} can be multiplied by a factor of 2.

The permissible load values given are valid with the load applied to the center of the output shaft (x_2).



"PA" Series – Advanced ServoFit® Precision Planetary Gearhead Shaft Loads

Output Bearing Options

"D" – Double Row Angular Contact Ball Bearing

Characteristics:

- Low frictional torque
- Good radial bearing capacity
- Axial load approx. 50% of radial load

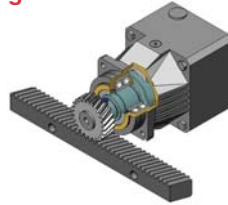

Applications:

- Helical geared rack/pinion
- Couplings with high axial load
- Belt with or without light tension

Permissible Motor Tilting Torque

The permissible tilting torque of the motor attached to the gear unit is a result of the static and dynamic load "F" from the motor weight, mass acceleration, and vibration multiplied by the distance from the center of gravity "ls" of the motor.

$$M_{IK} = F \times l_s \leq M_{IK}$$

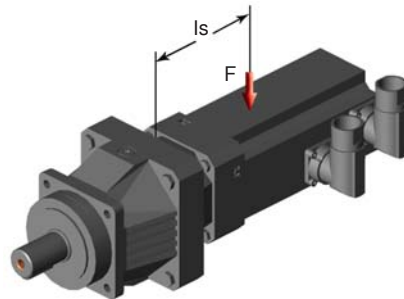

Table No. 2 M_{IK}

Unit Type with MT	Nm	inlbs.
PA322	10	88.5
PA321, PA422	20	177
PA421, PA522	40	354
PA521, PA722	80	708
PA721, PA822	200	1,770
PA821	400	3,540

No Load Running Torque

Table No. 3

T_R

Unit No.	Ratio																
	3	4	5	7	8	10	15	16	20	25	28	32	35	40	50	70	100
PA3 in.lbs.	2.7	1.8	1.8	1.8	1.8	1.8	—	1.3	1.3	.9	.9	.9	.9	.9	.9	.9	.9
Nm.	.3	.2	.2	.2	.2	.2	—	.15	.15	.1	.1	.1	.1	.1	.1	.1	.1
PA4 in.lbs.	4.4	3.5	3.5	2.7	2.7	2.7	2.7	2.7	1.8	1.8	1.8	1.8	1.8	1.8	1.8	1.8	1.8
Nm.	.5	.4	.4	.3	.3	.3	.3	.3	.2	.15	.15	.15	.15	.15	.15	.15	.15
PA5 in.lbs.	7.0	5.3	4.4	3.5	3.5	3.5	3.5	3.5	2.7	2.7	1.8	1.8	1.8	1.8	1.8	1.8	1.8
Nm.	.8	.6	.5	.4	.4	.4	.4	.4	.3	.3	.2	.2	.2	.2	.2	.2	.2
PA7 in.lbs.	8.0	6.2	5.3	4.4	4.4	4.4	6.2	4.4	3.5	1.8	3.5	3.5	3.5	3.5	3.5	3.5	3.5
Nm.	.9	.7	.6	.5	.5	.5	.7	.5	.4	.2	.4	.4	.4	.4	.4	.4	.4
PA8 in.lbs.	19.5	17.7	15.9	15.0	15.0	15.0	8.0	5.3	4.4	4.4	4.4	4.4	4.4	4.4	4.4	4.4	4.4
Nm.	2.2	2.0	1.8	1.7	1.7	1.7	.9	.6	.5	.5	.5	.5	.5	.5	.5	.5	.5

The torque is measured with the input at 2000 RPM and an ambient temperature of 20° C.



"PA" Series – Advanced ServoFit® Precision Planetary Gearhead Selection Data



Part Number (Gearhead + Input)	Exact Ratio i	Maximum Input Speed		Motor Shaft øD ⁶ mm	Input ¹⁾ Inertia J ₁ kgcm ²	Torsional Stiffness per arcmin C ₂		Output Torque					
		Continuous RPM (n ₁)	Cyclic RPM (n ₁)			in.lbs.	Nm	Nominal ²⁾ M _{2N}		Acceleration M _{2B}		Peak ³⁾ M _{2PEAK}	
								in.lbs.	Nm	in.lbs.	Nm	in.lbs.	Nm

PA321 with Motor Mounting Plate

PA321_0030 MF	3.000	3,500	6,000	≤11	0.68	43.1	4.9	266	30	443	50	567	64
PA321_0030 MF	3.000	3,500	6,000	>11≤14	0.69	44.3	5.0	266	30	443	50	954	108
PA321_0030 MF	3.000	3,500	6,000	>14≤19	0.69	44.3	5.0	266	30	443	50	1,083	122
PA321_0030 MFL	3.000	3,500	6,000	>19≤24	1.77	48.3	5.5	266	30	443	50	1,083	122
PA321_0040 MF	4.000	3,700	6,500	≤11	0.60	43.1	4.9	399	45	576	65	756	85
PA321_0040 MF	4.000	3,700	6,500	>11≤14	0.61	43.7	4.9	399	45	576	65	1,152	130
PA321_0040 MF	4.000	3,700	6,500	>14≤19	0.61	43.7	4.9	399	45	576	65	1,152	130
PA321_0040 MFL	4.000	3,700	6,500	>19≤24	1.69	45.9	5.2	399	45	576	65	1,152	130
PA321_0050 MF	5.000	4,000	7,000	≤11	0.55	42.8	4.8	399	45	576	65	945	107
PA321_0050 MF	5.000	4,000	7,000	>11≤14	0.57	43.2	4.9	399	45	576	65	1,152	130
PA321_0050 MF	5.000	4,000	7,000	>14≤19	0.57	43.2	4.9	399	45	576	65	1,152	130
PA321_0050 MFL	5.000	4,000	7,000	>19≤24	1.64	44.5	5.0	399	45	576	65	1,152	130
PA321_0070 MF	7.000	4,500	8,000	≤11	0.51	38.1	4.3	399	45	531	60	1,152	130
PA321_0070 MF	7.000	4,500	8,000	>11≤14	0.51	38.1	4.3	399	45	531	60	1,152	130
PA321_0070 MF	7.000	4,500	8,000	>14≤19	0.51	38.1	4.3	399	45	531	60	1,152	130
PA321_0070 MFL	7.000	4,500	8,000	>19≤24	1.57	38.7	4.4	399	45	531	60	1,152	130
PA321_0080 MF	8.000	4,500	8,000	≤11	0.50	36.6	4.1	354	40	443	50	886	100
PA321_0080 MF	8.000	4,500	8,000	>11≤14	0.50	36.6	4.1	354	40	443	50	886	100
PA321_0080 MF	8.000	4,500	8,000	>14≤19	0.50	36.6	4.1	354	40	443	50	886	100
PA321_0080 MFL	8.000	4,500	8,000	>19≤24	1.56	37.0	4.2	354	40	443	50	886	100
PA321_0100 MF	10.00	4,500	8,000	≤11	0.50	35.1	4.0	266	30	443	50	886	100
PA321_0100 MF	10.00	4,500	8,000	>11≤14	0.50	35.1	4.0	266	30	443	50	886	100
PA321_0100 MF	10.00	4,500	8,000	>14≤19	0.50	35.1	4.0	266	30	443	50	886	100
PA321_0100 MFL	10.00	4,500	8,000	>19≤24	1.56	35.3	4.0	266	30	443	50	886	100

PA322 with Motor Mounting Plate Continued Next Page

PA322_0120 MF	12.00	4,500	8,000	≤9	0.12	37.3	4.2	266	30	443	50	1,083	122
PA322_0120 MF	12.00	4,500	8,000	>9≤11	0.13	37.5	4.2	266	30	443	50	1,083	122
PA322_0120 MF	12.00	4,500	8,000	>11≤14	0.15	37.5	4.2	266	30	443	50	1,083	122
PA322_0160 MF	16.00	4,500	8,000	≤9	0.11	39.6	4.5	399	45	576	65	1,152	130
PA322_0160 MF	16.00	4,500	8,000	>9≤11	0.12	39.7	4.5	399	45	576	65	1,152	130
PA322_0160 MF	16.00	4,500	8,000	>11≤14	0.14	39.7	4.5	399	45	576	65	1,152	130
PA322_0200 MF	20.00	4,500	8,000	≤9	0.11	40.6	4.6	399	45	576	65	1,152	130
PA322_0200 MF	20.00	4,500	8,000	>9≤11	0.12	40.6	4.6	399	45	576	65	1,152	130
PA322_0200 MF	20.00	4,500	8,000	>11≤14	0.14	40.6	4.6	399	45	576	65	1,152	130
PA322_0250 MF	25.00	4,500	8,000	≤9	0.09	40.6	4.6	399	45	576	65	1,152	130
PA322_0250 MF	25.00	4,500	8,000	>9≤11	0.10	40.7	4.6	399	45	576	65	1,152	130
PA322_0250 MF	25.00	4,500	8,000	>11≤14	0.12	40.7	4.6	399	45	576	65	1,152	130
PA322_0280 MF	28.00	4,500	8,000	≤9	0.08	39.5	4.5	399	45	576	65	1,152	130
PA322_0280 MF	28.00	4,500	8,000	>9≤11	0.09	39.5	4.5	399	45	576	65	1,152	130
PA322_0280 MF	28.00	4,500	8,000	>11≤14	0.11	39.5	4.5	399	45	576	65	1,152	130
PA322_0320 MF	32.00	4,500	8,000	≤9	0.10	35.9	4.1	354	40	443	50	886	100
PA322_0320 MF	32.00	4,500	8,000	>9≤11	0.12	35.9	4.1	354	40	443	50	886	100
PA322_0320 MF	32.00	4,500	8,000	>11≤14	0.14	35.9	4.1	354	40	443	50	886	100
PA322_0350 MF	35.00	4,500	8,000	≤9	0.08	40.5	4.6	399	45	576	65	1,152	130
PA322_0350 MF	35.00	4,500	8,000	>9≤11	0.09	40.5	4.6	399	45	576	65	1,152	130
PA322_0350 MF	35.00	4,500	8,000	>11≤14	0.11	40.5	4.6	399	45	576	65	1,152	130

¹⁾ Inertia based on maximum input. For lower inertia using smaller diameter input, contact STOBER.

²⁾ Based on input speed: n₁ = 2000 RPM

For torque at higher input speeds (M_{2NX}) solve the formula, where n₁ = Actual Input Speed.

$$M_{2NX} = \frac{M_{2N}}{\sqrt[3]{\frac{n_1}{2000}}}$$

³⁾ Maximum momentary torque for emergency stops or heavy shock load. Admissible stops per life of gearhead = 1,000 stops maximum.



"PA" Series – Advanced ServoFit® Precision Planetary Gearhead Selection Data



P
A

Part Number (Gearhead + Input)	Exact Ratio i	Maximum Input Speed		Motor Shaft øD ⁶ mm	Input ¹⁾ Inertia J ₁ kgcm ²	Torsional Stiffness per arcmin		Output Torque					
		Continuous RPM (n ₁)	Cyclic RPM (n ₂)			C ₂		Nominal ²⁾		Acceleration		Peak ³⁾	
						in.lbs.	Nm	M _{2N}	Nm	M _{2B}	Nm	M _{2PEAK}	Nm

PA322 with Motor Mounting Plate *Continued*

PA322_0400 MF	40.00	4,500	8,000	≤9	0.07	38.8	4.4	399	45	576	65	1,152	130
PA322_0400 MF	40.00	4,500	8,000	>9≤11	0.08	38.8	4.4	399	45	576	65	1,152	130
PA322_0400 MF	40.00	4,500	8,000	>11≤14	0.10	38.8	4.4	399	45	576	65	1,152	130
PA322_0500 MF	50.00	4,500	8,000	≤9	0.07	40.0	4.5	399	45	576	65	1,152	130
PA322_0500 MF	50.00	4,500	8,000	>9≤11	0.08	40.0	4.5	399	45	576	65	1,152	130
PA322_0500 MF	50.00	4,500	8,000	>11≤14	0.10	40.0	4.5	399	45	576	65	1,152	130
PA322_0700 MF	70.00	4,500	8,000	≤9	0.07	36.9	4.2	399	45	531	60	1,152	130
PA322_0700 MF	70.00	4,500	8,000	>9≤11	0.08	36.9	4.2	399	45	531	60	1,152	130
PA322_0700 MF	70.00	4,500	8,000	>11≤14	0.10	36.9	4.2	399	45	531	60	1,152	130
PA322_1000 MF	100.0	4,500	8,000	≤9	0.07	34.6	3.9	266	30	443	50	886	100
PA322_1000 MF	100.0	4,500	8,000	>9≤11	0.08	34.6	3.9	266	30	443	50	886	100
PA322_1000 MF	100.0	4,500	8,000	>11≤14	0.10	34.6	3.9	266	30	443	50	886	100

PA421 with Motor Mounting Plate *Continued Next Page*

PA421_0030 MF	3.000	3,000	5,500	≤14	2.33	98.3	11.1	443	50	886	100	1,289	146
PA421_0030 MF	3.000	3,000	5,500	>14≤19	2.35	100.7	11.4	443	50	886	100	1,753	198
PA421_0030 MF	3.000	3,000	5,500	>19≤24	2.25	100.7	11.4	443	50	886	100	2,126	240
PA421_0030 MFC	3.000	4,500	6,000	≤14	2.66	98.3	11.1	443	50	886	100	1,289	146
PA421_0030 MFC	3.000	4,500	6,000	>14≤19	2.51	100.7	11.4	443	50	886	100	1,753	198
PA421_0030 MFC	3.000	4,500	6,000	>19≤24	2.40	100.7	11.4	443	50	886	100	2,126	240
PA421_0030 MFL	3.000	3,000	5,500	>24≤32	5.46	104.2	11.8	443	50	886	100	2,126	240
PA421_0030 MFLC	3.000	4,500	6,000	>24≤32	5.89	104.2	11.8	443	50	886	100	2,126	240
PA421_0040 MF	4.000	3,300	6,000	≤14	1.93	99.5	11.2	753	85	1,063	120	1,718	194
PA421_0040 MF	4.000	3,300	6,000	>14≤19	1.96	100.9	11.4	753	85	1,063	120	2,126	240
PA421_0040 MF	4.000	3,300	6,000	>19≤24	1.86	100.9	11.4	753	85	1,063	120	2,126	240
PA421_0040 MFC	4.000	5,000	6,000	≤14	2.27	99.5	11.2	753	85	1,063	120	1,718	194
PA421_0040 MFC	4.000	5,000	6,000	>14≤19	2.11	100.9	11.4	753	85	1,063	120	2,126	240
PA421_0040 MFC	4.000	5,000	6,000	>19≤24	2.01	100.9	11.4	753	85	1,063	120	2,126	240
PA421_0040 MFL	4.000	3,300	6,000	>24≤32	5.07	102.8	11.6	753	85	1,063	120	2,126	240
PA421_0040 MFLC	4.000	5,000	6,000	>24≤32	5.50	102.8	11.6	753	85	1,063	120	2,126	240
PA421_0050 MF	5.000	3,700	6,500	≤14	1.83	99.4	11.2	753	85	1,063	120	2,126	240
PA421_0050 MF	5.000	3,700	6,500	>14≤19	1.85	100.3	11.3	753	85	1,063	120	2,126	240
PA421_0050 MF	5.000	3,700	6,500	>19≤24	1.75	100.3	11.3	753	85	1,063	120	2,126	240
PA421_0050 MFC	5.000	5,000	6,500	≤14	2.16	99.4	11.2	753	85	1,063	120	2,126	240
PA421_0050 MFC	5.000	5,000	6,500	>14≤19	2.01	100.3	11.3	753	85	1,063	120	2,126	240
PA421_0050 MFC	5.000	5,000	6,500	>19≤24	1.90	100.3	11.3	753	85	1,063	120	2,126	240
PA421_0050 MFL	5.000	3,700	6,500	>24≤32	4.96	101.5	11.5	753	85	1,063	120	2,126	240
PA421_0050 MFLC	5.000	5,000	6,500	>24≤32	5.39	101.5	11.5	753	85	1,063	120	2,126	240
PA421_0070 MF	7.000	4,000	7,000	≤14	1.72	87.8	9.9	753	85	974	110	2,126	240
PA421_0070 MF	7.000	4,000	7,000	>14≤19	1.72	87.8	9.9	753	85	974	110	2,126	240
PA421_0070 MF	7.000	4,000	7,000	>19≤24	1.62	87.8	9.9	753	85	974	110	2,126	240
PA421_0070 MFC	7.000	5,500	7,000	≤14	2.05	87.8	9.9	753	85	974	110	2,126	240
PA421_0070 MFC	7.000	5,500	7,000	>14≤19	1.88	88.2	10.0	753	85	974	110	2,126	240
PA421_0070 MFC	7.000	5,500	7,000	>19≤24	1.77	87.8	9.9	753	85	974	110	2,126	240
PA421_0070 MFL	7.000	4,000	7,000	>24≤32	4.78	88.5	10.0	753	85	974	110	2,126	240
PA421_0070 MFLC	7.000	5,500	7,000	>24≤32	5.21	88.5	10.0	753	85	974	110	2,126	240
PA421_0080 MF	8.000	4,000	7,000	≤14	1.70	83.0	9.4	709	80	886	100	1,772	200
PA421_0080 MF	8.000	4,000	7,000	>14≤19	1.70	83.0	9.4	709	80	886	100	1,772	200
PA421_0080 MF	8.000	4,000	7,000	>19≤24	1.60	83.0	9.4	709	80	886	100	1,772	200

Index of Symbols: MF — Motor adapter with FlexiAdapt® coupling; L — Large Input; C — ServoCool

See Page 22 for Options and Part Number Configuration.



"PA" Series – Advanced ServoFit® Precision Planetary Gearhead Selection Data



Part Number (Gearhead + Input)	Exact Ratio i	Maximum Input Speed		Motor Shaft ØD ⁶ mm	Input ¹⁾ Inertia J ₁ kgcm ²	Torsional Stiffness per arcmin C ₂		Output Torque					
		Continuous RPM (n ₁)	Cyclic RPM (n ₁)			Nominal ²⁾		Acceleration		Peak ³⁾			
						M _{2N}	M _{2B}	M _{2B}	M _{2PEAK}				
Gearhead						in.lbs.	Nm	in.lbs.	Nm	in.lbs.	Nm	in.lbs.	Nm

PA421 with Motor Mounting Plate *Continued*

PA421_0080 MFC	8.000	5,500	7,000	≤14	2.03	83.0	9.4	709	80	886	100	1,772	200
PA421_0080 MFC	8.000	5,500	7,000	>14≤19	1.86	83.3	9.4	709	80	886	100	1,772	200
PA421_0080 MFC	8.000	5,500	7,000	>19≤24	1.75	83.0	9.4	709	80	886	100	1,772	200
PA421_0080 MFL	8.000	4,000	7,000	>24≤32	4.76	83.5	9.4	709	80	886	100	1,772	200
PA421_0080 MFLC	8.000	5,500	7,000	>24≤32	5.19	83.5	9.4	709	80	886	100	1,772	200
PA421_0100 MF	10.00	4,000	7,000	≤14	1.68	79.1	8.9	531	60	886	100	1,772	200
PA421_0100 MF	10.00	4,000	7,000	>14≤19	1.68	79.1	8.9	531	60	886	100	1,772	200
PA421_0100 MF	10.00	4,000	7,000	>19≤24	1.58	79.1	8.9	531	60	886	100	1,772	200
PA421_0100 MFC	10.00	6,000	7,000	≤14	2.01	79.1	8.9	531	60	886	100	1,772	200
PA421_0100 MFC	10.00	6,000	7,000	>14≤19	1.84	79.2	8.9	531	60	886	100	1,772	200
PA421_0100 MFC	10.00	6,000	7,000	>19≤24	1.73	79.1	8.9	531	60	886	100	1,772	200
PA421_0100 MFL	10.00	4,000	7,000	>24≤32	4.74	79.3	9.0	531	60	886	100	1,772	200
PA421_0100 MFLC	10.00	6,000	7,000	>24≤32	5.17	79.3	9.0	531	60	886	100	1,772	200

PA422 with Motor Mounting Plate *Continued Next Page*

PA422_0120 MF	12.00	3,700	6,500	≤11	0.64	86.1	9.7	443	50	886	100	2,126	240
PA422_0120 MF	12.00	3,700	6,500	>11≤14	0.65	86.4	9.8	443	50	886	100	2,126	240
PA422_0120 MF	12.00	3,700	6,500	>14≤19	0.65	86.4	9.8	443	50	886	100	2,126	240
PA422_0120 MFL	12.00	3,700	6,500	>19≤24	1.73	87.3	9.9	443	50	886	100	2,126	240
PA422_0120 MFLC	12.00	4,500	6,500	>19≤24	1.88	87.2	9.8	443	50	886	100	2,126	240
PA422_0160 MF	16.00	3,700	6,500	≤11	0.62	92.1	10.4	753	85	1,063	120	2,126	240
PA422_0160 MF	16.00	3,700	6,500	>11≤14	0.63	92.3	10.4	753	85	1,063	120	2,126	240
PA422_0160 MF	16.00	3,700	6,500	>14≤19	0.63	92.3	10.4	753	85	1,063	120	2,126	240
PA422_0160 MFL	16.00	3,700	6,500	>19≤24	1.70	92.8	10.5	753	85	1,063	120	2,126	240
PA422_0160 MFLC	16.00	5,000	6,500	>19≤24	1.86	92.8	10.5	753	85	1,063	120	2,126	240
PA422_0200 MF	20.00	3,700	6,500	≤11	0.61	94.5	10.7	753	85	1,063	120	2,126	240
PA422_0200 MF	20.00	3,700	6,500	>11≤14	0.62	94.7	10.7	753	85	1,063	120	2,126	240
PA422_0200 MF	20.00	3,700	6,500	>14≤19	0.62	94.7	10.7	753	85	1,063	120	2,126	240
PA422_0200 MFL	20.00	3,700	6,500	>19≤24	1.70	95.0	10.7	753	85	1,063	120	2,126	240
PA422_0200 MFLC	20.00	5,000	6,500	>19≤24	1.85	95.0	10.7	753	85	1,063	120	2,126	240
PA422_0250 MF	25.00	4,000	7,000	≤11	0.56	94.5	10.7	753	85	1,063	120	2,126	240
PA422_0250 MF	25.00	4,000	7,000	>11≤14	0.57	94.6	10.7	753	85	1,063	120	2,126	240
PA422_0250 MF	25.00	4,000	7,000	>14≤19	0.57	94.6	10.7	753	85	1,063	120	2,126	240
PA422_0250 MFL	25.00	4,000	7,000	>19≤24	1.65	94.8	10.7	753	85	1,063	120	2,126	240
PA422_0250 MFLC	25.00	5,000	7,000	>19≤24	1.80	94.8	10.7	753	85	1,063	120	2,126	240
PA422_0280 MF	28.00	4,500	8,000	≤11	0.52	90.5	10.2	753	85	1,063	120	2,126	240
PA422_0280 MF	28.00	4,500	8,000	>11≤14	0.52	90.5	10.2	753	85	1,063	120	2,126	240
PA422_0280 MF	28.00	4,500	8,000	>14≤19	0.52	90.5	10.2	753	85	1,063	120	2,126	240
PA422_0280 MFL	28.00	4,500	8,000	>19≤24	1.58	90.7	10.2	753	85	1,063	120	2,126	240
PA422_0280 MFLC	28.00	5,500	8,000	>19≤24	1.74	90.7	10.2	753	85	1,063	120	2,126	240
PA422_0320 MF	32.00	3,700	6,500	≤11	0.60	81.7	9.2	709	80	886	100	1,772	200
PA422_0320 MF	32.00	3,700	6,500	>11≤14	0.62	81.7	9.2	709	80	886	100	1,772	200
PA422_0320 MF	32.00	3,700	6,500	>14≤19	0.62	81.7	9.2	709	80	886	100	1,772	200
PA422_0320 MFL	32.00	3,700	6,500	>19≤24	1.69	81.8	9.2	709	80	886	100	1,772	200
PA422_0320 MFLC	32.00	5,000	6,500	>19≤24	1.84	81.8	9.2	709	80	886	100	1,772	200
PA422_0350 MF	35.00	4,500	8,000	≤11	0.52	93.5	10.6	753	85	1,063	120	2,126	240
PA422_0350 MF	35.00	4,500	8,000	>11≤14	0.52	93.5	10.6	753	85	1,063	120	2,126	240
PA422_0350 MF	35.00	4,500	8,000	>14≤19	0.52	93.5	10.6	753	85	1,063	120	2,126	240
PA422_0350 MFL	35.00	4,500	8,000	>19≤24	1.58	93.6	10.6	753	85	1,063	120	2,126	240
PA422_0350 MFLC	35.00	5,500	8,000	>19≤24	1.73	93.6	10.6	753	85	1,063	120	2,126	240

¹⁾ Inertia based on maximum input. For lower inertia using smaller diameter input, contact STOBER.

²⁾ Based on input speed: n₁ = 2000 RPM

For torque at higher input speeds (M_{2NX}) solve the formula, where n₁ = Actual Input Speed.

$$M_{2NX} = \frac{M_{2N}}{\sqrt[3]{\frac{n_1}{2000}}}$$

³⁾ Maximum momentary torque for emergency stops or heavy shock load. Admissible stops per life of gearhead = 1,000 stops maximum.



"PA" Series – Advanced ServoFit® Precision Planetary Gearhead Selection Data



PA

Part Number (Gearhead + Input)	Exact Ratio i	Maximum Input Speed		Motor Shaft øD ⁶ mm	Input ¹⁾ Inertia J ₁ kgcm ²	Torsional Stiffness per arcmin		Output Torque					
		Continuous RPM (n ₁)	Cyclic			C ₂		Nominal ²⁾		Acceleration		Peak ³⁾	
						in.lbs.	Nm	M _{2N}	Nm	M _{2B}	Nm	M _{2PEAK}	Nm

PA422 with Motor Mounting Plate *Continued*

PA422_0400 MF	40.00	4,500	8,000	≤11	0.50	89.4	10.1	753	85	1,063	120	2,126	240
PA422_0400 MF	40.00	4,500	8,000	>11≤14	0.50	89.4	10.1	753	85	1,063	120	2,126	240
PA422_0400 MF	40.00	4,500	8,000	>14≤19	0.50	89.4	10.1	753	85	1,063	120	2,126	240
PA422_0400 MFL	40.00	4,500	8,000	>19≤24	1.56	89.5	10.1	753	85	1,063	120	2,126	240
PA422_0400 MFLC	40.00	5,500	8,000	>19≤24	1.71	89.5	10.1	753	85	1,063	120	2,126	240
PA422_0500 MF	50.00	4,500	8,000	≤11	0.50	92.7	10.5	753	85	1,063	120	2,126	240
PA422_0500 MF	50.00	4,500	8,000	>11≤14	0.50	92.7	10.5	753	85	1,063	120	2,126	240
PA422_0500 MF	50.00	4,500	8,000	>14≤19	0.50	92.7	10.5	753	85	1,063	120	2,126	240
PA422_0500 MFL	50.00	4,500	8,000	>19≤24	1.56	92.7	10.5	753	85	1,063	120	2,126	240
PA422_0500 MFLC	50.00	5,500	8,000	>19≤24	1.71	92.7	10.5	753	85	1,063	120	2,126	240
PA422_0700 MF	70.00	4,500	8,000	≤11	0.50	85.0	9.6	753	85	974	110	2,126	240
PA422_0700 MF	70.00	4,500	8,000	>11≤14	0.50	85.0	9.6	753	85	974	110	2,126	240
PA422_0700 MF	70.00	4,500	8,000	>14≤19	0.50	85.0	9.6	753	85	974	110	2,126	240
PA422_0700 MFL	70.00	4,500	8,000	>19≤24	1.56	85.1	9.6	753	85	974	110	2,126	240
PA422_0700 MFLC	70.00	5,500	8,000	>19≤24	1.71	85.1	9.6	753	85	974	110	2,126	240
PA422_1000 MF	100.0	4,500	8,000	≤11	0.50	78.0	8.8	531	60	886	100	1,772	200
PA422_1000 MF	100.0	4,500	8,000	>11≤14	0.50	78.0	8.8	531	60	886	100	1,772	200
PA422_1000 MF	100.0	4,500	8,000	>14≤19	0.50	78.0	8.8	531	60	886	100	1,772	200
PA422_1000 MFL	100.0	4,500	8,000	>19≤24	1.56	78.0	8.8	531	60	886	100	1,772	200
PA422_1000 MFLC	100.0	5,500	8,000	>19≤24	1.71	78.0	8.8	531	60	886	100	1,772	200

PA521 with Motor Mounting Plate *Continued Next Page*

PA521_0030 MF	3.000	2,500	4,500	≤19	6.07	262.7	29.7	1,063	120	1,772	200	2,294	259
PA521_0030 MF	3.000	2,500	4,500	>19≤24	6.14	271.7	30.7	1,063	120	1,772	200	3,686	416
PA521_0030 MF	3.000	2,500	4,500	>24≤32	6.04	271.7	30.7	1,063	120	1,772	200	3,686	416
PA521_0030 MF	3.000	2,500	4,500	>32≤35	6.04	271.7	30.7	1,063	120	1,772	200	3,686	416
PA521_0030 MFC	3.000	4,000	6,000	≤19	6.98	262.7	29.7	1,063	120	1,772	200	2,294	259
PA521_0030 MFC	3.000	4,000	6,000	>19≤24	6.59	271.7	30.7	1,063	120	1,772	200	3,686	416
PA521_0030 MFC	3.000	4,000	6,000	>24≤32	6.47	271.7	30.7	1,063	120	1,772	200	3,686	416
PA521_0030 MFL	3.000	2,500	4,500	>32≤38	13.23	292.1	33.0	1,063	120	1,772	200	3,686	416
PA521_0030 MFLC	3.000	4,000	6,000	>32≤38	16.02	292.1	33.0	1,063	120	1,772	200	3,686	416
PA521_0040 MF	4.000	3,000	5,000	≤19	5.85	255.8	28.9	1,860	210	2,447	276	3,059	345
PA521_0040 MF	4.000	3,000	5,000	>19≤24	5.93	260.6	29.4	1,860	210	2,657	300	4,915	555
PA521_0040 MF	4.000	3,000	5,000	>24≤32	5.83	260.6	29.4	1,860	210	2,657	300	4,915	555
PA521_0040 MF	4.000	3,000	5,000	>32≤35	5.83	260.6	29.4	1,860	210	2,657	300	4,915	555
PA521_0040 MFC	4.000	4,500	6,000	≤19	6.77	255.8	28.9	1,860	210	2,447	276	3,059	345
PA521_0040 MFC	4.000	4,500	6,000	>19≤24	6.38	260.6	29.4	1,860	210	2,657	300	4,915	555
PA521_0040 MFC	4.000	4,500	6,000	>24≤32	6.26	260.6	29.4	1,860	210	2,657	300	4,915	555
PA521_0040 MFL	4.000	3,000	5,000	>32≤38	13.02	270.8	30.6	1,860	210	2,657	300	4,915	555
PA521_0040 MFLC	4.000	4,500	6,000	>32≤38	15.81	270.8	30.6	1,860	210	2,657	300	4,915	555
PA521_0050 MF	5.000	3,500	6,000	≤19	5.44	257.7	29.1	1,860	210	2,657	300	3,824	432
PA521_0050 MF	5.000	3,500	6,000	>19≤24	5.52	260.7	29.4	1,860	210	2,657	300	5,315	600
PA521_0050 MF	5.000	3,500	6,000	>24≤32	5.42	260.7	29.4	1,860	210	2,657	300	5,315	600
PA521_0050 MF	5.000	3,500	6,000	>32≤35	5.42	260.7	29.4	1,860	210	2,657	300	5,315	600
PA521_0050 MFC	5.000	5,000	6,000	≤19	6.36	257.7	29.1	1,860	210	2,657	300	3,824	432
PA521_0050 MFC	5.000	5,000	6,000	>19≤24	5.97	260.7	29.4	1,860	210	2,657	300	5,315	600
PA521_0050 MFC	5.000	5,000	6,000	>24≤32	5.85	260.7	29.4	1,860	210	2,657	300	5,315	600
PA521_0050 MFL	5.000	3,500	6,000	>32≤38	12.61	267.2	30.2	1,860	210	2,657	300	5,315	600
PA521_0050 MFLC	5.000	5,000	6,000	>32≤38	15.40	267.2	30.2	1,860	210	2,657	300	5,315	600

Index of Symbols: MF — Motor adapter with FlexiAdapt® coupling; L — Large Input; C — ServoCool

See Page 22 for Options and Part Number Configuration.



"PA" Series – Advanced ServoFit® Precision Planetary Gearhead Selection Data



Part Number (Gearhead + Input)	Exact Ratio i	Maximum Input Speed		Motor Shaft øD ⁶ mm	Input ¹⁾ Inertia J ₁ kgcm ²	Torsional Stiffness per arcmin C ₂		Output Torque					
		Continuous RPM (n ₁)	Cyclic RPM (n ₁)			in.lbs.	Nm	Nominal ²⁾ M _{2N}		Acceleration M _{2B}		Peak ³⁾ M _{2PEAK}	
								in.lbs.	Nm	in.lbs.	Nm	in.lbs.	Nm

PA521 with Motor Mounting Plate *Continued*

PA521_0070 MF	7.000	3,700	6,500	≤19	5.07	240.4	27.1	1,860	210	2,392	270	5,315	600
PA521_0070 MF	7.000	3,700	6,500	>19≤24	5.07	240.4	27.1	1,860	210	2,392	270	5,315	600
PA521_0070 MF	7.000	3,700	6,500	>24≤32	4.97	240.4	27.1	1,860	210	2,392	270	5,315	600
PA521_0070 MF	7.000	3,700	6,500	>32≤35	4.97	240.4	27.1	1,860	210	2,392	270	5,315	600
PA521_0070 MFC	7.000	5,000	6,500	≤19	5.98	240.4	27.1	1,860	210	2,392	270	5,315	600
PA521_0070 MFC	7.000	5,000	6,500	>19≤24	5.52	240.4	27.1	1,860	210	2,392	270	5,315	600
PA521_0070 MFC	7.000	5,000	6,500	>24≤32	5.40	240.4	27.1	1,860	210	2,392	270	5,315	600
PA521_0070 MFL	7.000	3,700	6,500	>32≤38	11.90	243.7	27.5	1,860	210	2,392	270	5,315	600
PA521_0070 MFLC	7.000	5,000	6,500	>32≤38	14.69	243.7	27.5	1,860	210	2,392	270	5,315	600
PA521_0080 MF	8.000	3,700	6,500	≤19	5.00	225.2	25.4	1,772	200	2,215	250	4,429	500
PA521_0080 MF	8.000	3,700	6,500	>19≤24	5.00	225.2	25.4	1,772	200	2,215	250	4,429	500
PA521_0080 MF	8.000	3,700	6,500	>24≤32	4.90	225.2	25.4	1,772	200	2,215	250	4,429	500
PA521_0080 MF	8.000	3,700	6,500	>32≤35	4.90	225.2	25.4	1,772	200	2,215	250	4,429	500
PA521_0080 MFC	8.000	5,500	6,500	≤19	5.91	225.2	25.4	1,772	200	2,215	250	4,429	500
PA521_0080 MFC	8.000	5,500	6,500	>19≤24	5.45	225.2	25.4	1,772	200	2,215	250	4,429	500
PA521_0080 MFC	8.000	5,500	6,500	>24≤32	5.33	225.2	25.4	1,772	200	2,215	250	4,429	500
PA521_0080 MFL	8.000	3,700	6,500	>32≤38	11.83	227.4	25.7	1,772	200	2,215	250	4,429	500
PA521_0080 MFLC	8.000	5,500	6,500	>32≤38	14.63	227.4	25.7	1,772	200	2,215	250	4,429	500
PA521_0100 MF	10.00	3,700	6,500	≤19	4.94	218.4	24.7	1,240	140	2,215	250	4,429	500
PA521_0100 MF	10.00	3,700	6,500	>19≤24	4.94	218.4	24.7	1,240	140	2,215	250	4,429	500
PA521_0100 MF	10.00	3,700	6,500	>24≤32	4.84	218.4	24.7	1,240	140	2,215	250	4,429	500
PA521_0100 MF	10.00	3,700	6,500	>32≤35	4.84	218.4	24.7	1,240	140	2,215	250	4,429	500
PA521_0100 MFC	10.00	6,000	6,500	≤19	5.85	218.4	24.7	1,240	140	2,215	250	4,429	500
PA521_0100 MFC	10.00	6,000	6,500	>19≤24	5.39	218.4	24.7	1,240	140	2,215	250	4,429	500
PA521_0100 MFC	10.00	6,000	6,500	>24≤32	5.27	218.4	24.7	1,240	140	2,215	250	4,429	500
PA521_0100 MFL	10.00	3,700	6,500	>32≤38	11.77	219.7	24.8	1,240	140	2,215	250	4,429	500
PA521_0100 MFLC	10.00	6,000	6,500	>32≤38	14.56	219.7	24.8	1,240	140	2,215	250	4,429	500

PA522 with Motor Mounting Plate *Continued Next Page*

PA522_0120 MF	12.00	3,300	6,000	≤14	2.00	236.6	26.7	1,063	120	1,772	200	3,686	416
PA522_0120 MF	12.00	3,300	6,000	>14≤19	2.02	237.5	26.8	1,063	120	1,772	200	3,686	416
PA522_0120 MF	12.00	3,300	6,000	>19≤24	1.92	237.5	26.8	1,063	120	1,772	200	3,686	416
PA522_0120 MFC	12.00	4,500	6,000	≤14	2.33	236.6	26.7	1,063	120	1,772	200	3,686	416
PA522_0120 MFC	12.00	4,500	6,000	>14≤19	2.18	237.5	26.8	1,063	120	1,772	200	3,686	416
PA522_0120 MFC	12.00	4,500	6,000	>19≤24	2.07	237.5	26.8	1,063	120	1,772	200	3,686	416
PA522_0120 MFL	12.00	3,300	6,000	>24≤32	5.13	238.6	26.9	1,063	120	1,772	200	3,686	416
PA522_0120 MFLC	12.00	4,500	6,000	>24≤32	5.56	238.6	26.9	1,063	120	1,772	200	3,686	416
PA522_0160 MF	16.00	3,300	6,000	≤14	1.98	241.3	27.2	1,860	210	2,657	300	4,915	555
PA522_0160 MF	16.00	3,300	6,000	>14≤19	2.01	241.8	27.3	1,860	210	2,657	300	4,915	555
PA522_0160 MF	16.00	3,300	6,000	>19≤24	1.91	241.8	27.3	1,860	210	2,657	300	4,915	555
PA522_0160 MFC	16.00	5,000	6,000	≤14	2.32	241.3	27.2	1,860	210	2,657	300	4,915	555
PA522_0160 MFC	16.00	5,000	6,000	>14≤19	2.16	241.8	27.3	1,860	210	2,657	300	4,915	555
PA522_0160 MFC	16.00	5,000	6,000	>19≤24	2.06	241.8	27.3	1,860	210	2,657	300	4,915	555
PA522_0160 MFL	16.00	3,300	6,000	>24≤32	5.12	242.4	27.4	1,860	210	2,657	300	4,915	555
PA522_0160 MFLC	16.00	5,000	6,000	>24≤32	5.55	242.4	27.4	1,860	210	2,657	300	4,915	555
PA522_0200 MF	20.00	3,300	6,000	≤14	1.96	248.0	28.0	1,860	210	2,657	300	5,315	600
PA522_0200 MF	20.00	3,300	6,000	>14≤19	1.98	248.4	28.0	1,860	210	2,657	300	5,315	600
PA522_0200 MF	20.00	3,300	6,000	>19≤24	1.88	248.4	28.0	1,860	210	2,657	300	5,315	600
PA522_0200 MFC	20.00	5,000	6,000	≤14	2.29	248.0	28.0	1,860	210	2,657	300	5,315	600
PA522_0200 MFC	20.00	5,000	6,000	>14≤19	2.14	248.4	28.0	1,860	210	2,657	300	5,315	600

¹⁾ Inertia based on maximum input. For lower inertia using smaller diameter input, contact STOBER.

²⁾ Based on input speed: n₁ = 2000 RPM

For torque at higher input speeds (M_{2NX}) solve the formula, where n₁ = Actual Input Speed.

$$M_{2NX} = \frac{M_{2N}}{\sqrt[3]{\frac{n_1}{2000}}}$$

³⁾ Maximum momentary torque for emergency stops or heavy shock load. Admissible stops per life of gearhead = 1,000 stops maximum.



"PA" Series – Advanced ServoFit® Precision Planetary Gearhead Selection Data



PA

Part Number (Gearhead + Input)	Exact Ratio i	Maximum Input Speed		Motor Shaft øD ⁶ mm	Input ¹⁾ Inertia J ₁ kgcm ²	Torsional Stiffness per arcmin C ₂		Output Torque					
		Continuous RPM (n ₁)	Cyclic			in.lbs.	Nm	Nominal ²⁾		Acceleration		Peak ³⁾	
								M _{2N}	M _{2B}	M _{2PEAK}	M _{2PEAK}		

PA522 with Motor Mounting Plate *Continued Next Page*

PA522_0200 MFC	20.00	5,000	6,000	>19≤24	2.03	248.4	28.0	1,860	210	2,657	300	5,315	600
PA522_0200 MFL	20.00	3,300	6,000	>24≤32	5.09	248.8	28.1	1,860	210	2,657	300	5,315	600
PA522_0200 MFLC	20.00	5,000	6,000	>24≤32	5.52	248.8	28.1	1,860	210	2,657	300	5,315	600
PA522_0250 MF	25.00	3,700	6,500	≤14	1.85	248.0	28.0	1,860	210	2,657	300	5,315	600
PA522_0250 MF	25.00	3,700	6,500	>14≤19	1.87	248.2	28.0	1,860	210	2,657	300	5,315	600
PA522_0250 MF	25.00	3,700	6,500	>19≤24	1.77	248.2	28.0	1,860	210	2,657	300	5,315	600
PA522_0250 MFC	25.00	5,000	6,500	≤14	2.18	248.0	28.0	1,860	210	2,657	300	5,315	600
PA522_0250 MFC	25.00	5,000	6,500	>14≤19	2.03	248.2	28.0	1,860	210	2,657	300	5,315	600
PA522_0250 MFC	25.00	5,000	6,500	>19≤24	1.92	248.2	28.0	1,860	210	2,657	300	5,315	600
PA522_0250 MFL	25.00	3,700	6,500	>24≤32	4.98	248.5	28.1	1,860	210	2,657	300	5,315	600
PA522_0250 MFLC	25.00	5,000	6,500	>24≤32	5.41	248.5	28.1	1,860	210	2,657	300	5,315	600
PA522_0280 MF	28.00	4,000	7,000	≤14	1.75	236.5	26.7	1,860	210	2,657	300	4,915	555
PA522_0280 MF	28.00	4,000	7,000	>14≤19	1.75	236.5	26.7	1,860	210	2,657	300	4,915	555
PA522_0280 MF	28.00	4,000	7,000	>19≤24	1.65	236.5	26.7	1,860	210	2,657	300	4,915	555
PA522_0280 MFC	28.00	5,500	7,000	≤14	2.08	236.5	26.7	1,860	210	2,657	300	4,915	555
PA522_0280 MFC	28.00	5,500	7,000	>14≤19	1.90	236.6	26.7	1,860	210	2,657	300	4,915	555
PA522_0280 MFC	28.00	5,500	7,000	>19≤24	1.80	236.5	26.7	1,860	210	2,657	300	4,915	555
PA522_0280 MFL	28.00	4,000	7,000	>24≤32	4.81	236.8	26.7	1,860	210	2,657	300	4,915	555
PA522_0280 MFLC	28.00	5,500	7,000	>24≤32	5.24	236.8	26.7	1,860	210	2,657	300	4,915	555
PA522_0320 MF	32.00	3,300	6,000	≤14	1.93	222.3	25.1	1,772	200	2,215	250	4,429	500
PA522_0320 MF	32.00	3,300	6,000	>14≤19	1.95	222.4	25.1	1,772	200	2,215	250	4,429	500
PA522_0320 MF	32.00	3,300	6,000	>19≤24	1.85	222.4	25.1	1,772	200	2,215	250	4,429	500
PA522_0320 MFC	32.00	5,000	6,000	≤14	2.27	222.3	25.1	1,772	200	2,215	250	4,429	500
PA522_0320 MFC	32.00	5,000	6,000	>14≤19	2.11	222.4	25.1	1,772	200	2,215	250	4,429	500
PA522_0320 MFC	32.00	5,000	6,000	>19≤24	2.01	222.4	25.1	1,772	200	2,215	250	4,429	500
PA522_0320 MFL	32.00	3,300	6,000	>24≤32	5.06	222.5	25.1	1,772	200	2,215	250	4,429	500
PA522_0320 MFLC	32.00	5,000	6,000	>24≤32	5.49	222.5	25.1	1,772	200	2,215	250	4,429	500
PA522_0350 MF	35.00	4,000	7,000	≤14	1.74	244.8	27.6	1,860	210	2,657	300	5,315	600
PA522_0350 MF	35.00	4,000	7,000	>14≤19	1.74	244.8	27.6	1,860	210	2,657	300	5,315	600
PA522_0350 MF	35.00	4,000	7,000	>19≤24	1.64	244.8	27.6	1,860	210	2,657	300	5,315	600
PA522_0350 MFC	35.00	5,500	7,000	≤14	2.07	244.8	27.6	1,860	210	2,657	300	5,315	600
PA522_0350 MFC	35.00	5,500	7,000	>14≤19	1.90	244.9	27.6	1,860	210	2,657	300	5,315	600
PA522_0350 MFC	35.00	5,500	7,000	>19≤24	1.79	244.8	27.6	1,860	210	2,657	300	5,315	600
PA522_0350 MFL	35.00	4,000	7,000	>24≤32	4.80	245.0	27.7	1,860	210	2,657	300	5,315	600
PA522_0350 MFLC	35.00	5,500	7,000	>24≤32	5.23	245.0	27.7	1,860	210	2,657	300	5,315	600
PA522_0400 MF	40.00	4,000	7,000	≤14	1.69	232.2	26.2	1,860	210	2,657	300	4,915	555
PA522_0400 MF	40.00	4,000	7,000	>14≤19	1.69	232.2	26.2	1,860	210	2,657	300	4,915	555
PA522_0400 MF	40.00	4,000	7,000	>19≤24	1.59	232.2	26.2	1,860	210	2,657	300	4,915	555
PA522_0400 MFC	40.00	5,500	7,000	≤14	2.03	232.2	26.2	1,860	210	2,657	300	4,915	555
PA522_0400 MFC	40.00	5,500	7,000	>14≤19	1.85	232.2	26.2	1,860	210	2,657	300	4,915	555
PA522_0400 MFC	40.00	5,500	7,000	>19≤24	1.75	232.2	26.2	1,860	210	2,657	300	4,915	555
PA522_0400 MFL	40.00	4,000	7,000	>24≤32	4.75	232.3	26.2	1,860	210	2,657	300	4,915	555
PA522_0400 MFLC	40.00	5,500	7,000	>24≤32	5.18	232.3	26.2	1,860	210	2,657	300	4,915	555
PA522_0500 MF	50.00	4,000	7,000	≤14	1.69	241.8	27.3	1,860	210	2,657	300	5,315	600
PA522_0500 MF	50.00	4,000	7,000	>14≤19	1.69	241.8	27.3	1,860	210	2,657	300	5,315	600
PA522_0500 MF	50.00	4,000	7,000	>19≤24	1.59	241.8	27.3	1,860	210	2,657	300	5,315	600
PA522_0500 MFC	50.00	5,500	7,000	≤14	2.02	241.8	27.3	1,860	210	2,657	300	5,315	600
PA522_0500 MFC	50.00	5,500	7,000	>14≤19	1.85	241.8	27.3	1,860	210	2,657	300	5,315	600
PA522_0500 MFC	50.00	5,500	7,000	>19≤24	1.74	241.8	27.3	1,860	210	2,657	300	5,315	600

Index of Symbols: MF — Motor adapter with FlexiAdapt® coupling; L — Large Input; C — ServoCool

See Page 22 for Options and Part Number Configuration.



"PA" Series – Advanced ServoFit® Precision Planetary Gearhead Selection Data



Part Number (Gearhead + Input)	Exact Ratio i	Maximum Input Speed		Motor Shaft ØD ⁶ mm	Input ¹⁾ Inertia J ₁ kgcm ²	Torsional Stiffness per arcmin C ₂		Output Torque					
		Continuous RPM (n ₁)	Cyclic			in.lbs.	Nm	Nominal ²⁾		Acceleration		Peak ³⁾	
								M _{2N}	M _{2B}	M _{2PEAK}	M _{2PEAK}		

PA522 with Motor Mounting Plate Continued

PA522_0500 MFL	50.00	4,000	7,000	>24≤32	4.75	241.9	27.3	1,860	210	2,657	300	5,315	600
PA522_0500 MFLC	50.00	5,500	7,000	>24≤32	5.18	241.9	27.3	1,860	210	2,657	300	5,315	600
PA522_0700 MF	70.00	4,000	7,000	≤14	1.69	233.1	26.3	1,860	210	2,392	270	5,315	600
PA522_0700 MF	70.00	4,000	7,000	>14≤19	1.69	233.1	26.3	1,860	210	2,392	270	5,315	600
PA522_0700 MF	70.00	4,000	7,000	>19≤24	1.59	233.1	26.3	1,860	210	2,392	270	5,315	600
PA522_0700 MFC	70.00	5,500	7,000	≤14	2.02	233.1	26.3	1,860	210	2,392	270	5,315	600
PA522_0700 MFC	70.00	5,500	7,000	>14≤19	1.84	233.1	26.3	1,860	210	2,392	270	5,315	600
PA522_0700 MFC	70.00	5,500	7,000	>19≤24	1.74	233.1	26.3	1,860	210	2,392	270	5,315	600
PA522_0700 MFL	70.00	4,000	7,000	>24≤32	4.75	233.1	26.3	1,860	210	2,392	270	5,315	600
PA522_0700 MFLC	70.00	5,500	7,000	>24≤32	5.18	233.1	26.3	1,860	210	2,392	270	5,315	600
PA522_1000 MF	100.0	4,000	7,000	≤14	1.69	215.4	24.3	1,240	140	2,215	250	4,429	500
PA522_1000 MF	100.0	4,000	7,000	>14≤19	1.69	215.4	24.3	1,240	140	2,215	250	4,429	500
PA522_1000 MF	100.0	4,000	7,000	>19≤24	1.59	215.4	24.3	1,240	140	2,215	250	4,429	500
PA522_1000 MFC	100.0	5,500	7,000	≤14	2.02	215.4	24.3	1,240	140	2,215	250	4,429	500
PA522_1000 MFC	100.0	5,500	7,000	>14≤19	1.84	215.4	24.3	1,240	140	2,215	250	4,429	500
PA522_1000 MFC	100.0	5,500	7,000	>19≤24	1.74	215.4	24.3	1,240	140	2,215	250	4,429	500
PA522_1000 MFL	100.0	4,000	7,000	>24≤32	4.75	215.4	24.3	1,240	140	2,215	250	4,429	500
PA522_1000 MFLC	100.0	5,500	7,000	>24≤32	5.18	215.4	24.3	1,240	140	2,215	250	4,429	500

PA721 with Motor Mounting Plate Continued Next Page

PA721_0030 MF	3.000	2,200	3,700	≤24	19.91	466.8	52.7	2,480	280	3,815	431	4,769	538
PA721_0030 MF	3.000	2,200	3,700	>24≤32	20.25	484.5	54.7	2,480	280	4,429	500	8,945	1,010
PA721_0030 MF	3.000	2,200	3,700	>32≤38	20.25	484.5	54.7	2,480	280	4,429	500	9,177	1,036
PA721_0030 MFC	3.000	3,400	6,000	≤24	22.67	484.5	54.7	2,480	280	4,429	500	6,702	757
PA721_0030 MFC	3.000	3,400	6,000	>24≤32	21.45	484.5	54.7	2,480	280	4,429	500	8,945	1,010
PA721_0030 MFC	3.000	3,400	6,000	>32≤38	23.04	484.5	54.7	2,480	280	4,429	500	9,177	1,036
PA721_0030 MFL	3.000	2,200	3,700	>38≤48	22.26	520.9	58.8	2,480	280	4,429	500	9,177	1,036
PA721_0030 MFLC	3.000	3,400	6,000	>38≤48	38.12	520.9	58.8	2,480	280	4,429	500	9,177	1,036
PA721_0040 MF	4.000	2,500	4,500	≤24	15.20	475.7	53.7	3,898	440	5,087	574	6,358	718
PA721_0040 MF	4.000	2,500	4,500	>24≤32	15.53	485.9	54.9	3,898	440	6,201	700	11,926	1,346
PA721_0040 MF	4.000	2,500	4,500	>32≤38	15.53	485.9	54.9	3,898	440	6,201	700	12,235	1,381
PA721_0040 MFC	4.000	3,600	6,000	≤24	17.95	485.9	54.9	3,898	440	6,201	700	8,936	1,009
PA721_0040 MFC	4.000	3,600	6,000	>24≤32	16.73	485.9	54.9	3,898	440	6,201	700	11,926	1,346
PA721_0040 MFC	4.000	3,600	6,000	>32≤38	18.33	485.9	54.9	3,898	440	6,201	700	12,235	1,381
PA721_0040 MFL	4.000	2,500	4,500	>38≤48	17.55	505.8	57.1	3,898	440	6,201	700	12,235	1,381
PA721_0040 MFLC	4.000	3,600	6,000	>38≤48	33.41	505.8	57.1	3,898	440	6,201	700	12,235	1,381
PA721_0050 MF	5.000	3,000	5,500	≤24	13.66	475.2	53.6	3,898	440	6,201	700	7,948	897
PA721_0050 MF	5.000	3,000	5,500	>24≤32	14.00	481.6	54.4	3,898	440	6,201	700	12,401	1,400
PA721_0050 MF	5.000	3,000	5,500	>32≤38	14.00	481.6	54.4	3,898	440	6,201	700	12,401	1,400
PA721_0050 MFC	5.000	4,200	6,000	≤24	16.41	481.6	54.4	3,898	440	6,201	700	11,170	1,261
PA721_0050 MFC	5.000	4,200	6,000	>24≤32	15.20	481.6	54.4	3,898	440	6,201	700	12,401	1,400
PA721_0050 MFC	5.000	4,200	6,000	>32≤38	16.79	481.6	54.4	3,898	440	6,201	700	12,401	1,400
PA721_0050 MFL	5.000	3,000	5,500	>38≤48	16.01	494.0	55.8	3,898	440	6,201	700	12,401	1,400
PA721_0050 MFLC	5.000	4,200	6,000	>38≤48	31.87	494.0	55.8	3,898	440	6,201	700	12,401	1,400
PA721_0070 MF	7.000	3,300	6,000	≤24	12.66	470.7	53.1	3,898	440	5,758	650	11,127	1,256
PA721_0070 MF	7.000	3,300	6,000	>24≤32	12.66	470.7	53.1	3,898	440	5,758	650	11,127	1,256
PA721_0070 MF	7.000	3,300	6,000	>32≤38	12.66	470.7	53.1	3,898	440	5,758	650	11,127	1,256
PA721_0070 MFC	7.000	4,700	6,000	≤24	15.08	470.7	53.1	3,898	440	5,758	650	11,127	1,256
PA721_0070 MFC	7.000	4,700	6,000	>24≤32	13.87	470.7	53.1	3,898	440	5,758	650	11,127	1,256

¹⁾ Inertia based on maximum input. For lower inertia using smaller diameter input, contact STOBER.

²⁾ Based on input speed: n₁ = 2000 RPM

For torque at higher input speeds (M_{2NX}) solve the formula, where n₁ = Actual Input Speed.

$$M_{2NX} = \frac{M_{2N}}{\sqrt[3]{\frac{n_1}{2000}}}$$

³⁾ Maximum momentary torque for emergency stops or heavy shock load. Admissible stops per life of gearhead = 1,000 stops maximum.



"PA" Series – Advanced ServoFit® Precision Planetary Gearhead Selection Data



P
A

Part Number (Gearhead + Input)	Exact Ratio i	Maximum Input Speed		Motor Shaft øD ⁶ mm	Input ¹⁾ Inertia J ₁ kgcm ²	Torsional Stiffness per arcmin		Output Torque					
		Continuous RPM (n ₁)	Cyclic RPM (n ₂)			C ₂		Nominal ²⁾		Acceleration		Peak ³⁾	
						in.lbs.	Nm	M _{2N}	Nm	M _{2B}	Nm	M _{2PEAK}	Nm

PA721 with Motor Mounting Plate *Continued*

PA721_0070 MFC	7.000	4,700	6,000	>32≤38	15.46	470.7	53.1	3,898	440	5,758	650	11,127	1,256
PA721_0070 MFL	7.000	3,300	6,000	>38≤48	15.03	478.7	54.0	3,898	440	5,758	650	11,127	1,256
PA721_0070 MFLC	7.000	4,700	6,000	>38≤48	30.89	478.7	54.0	3,898	440	5,758	650	11,127	1,256
PA721_0080 MF	8.000	3,300	6,000	≤24	12.40	457.6	51.7	3,543	400	4,429	500	8,858	1,000
PA721_0080 MF	8.000	3,300	6,000	>24≤32	12.40	457.6	51.7	3,543	400	4,429	500	8,858	1,000
PA721_0080 MF	8.000	3,300	6,000	>32≤38	12.40	457.6	51.7	3,543	400	4,429	500	8,858	1,000
PA721_0080 MFC	8.000	5,000	6,000	≤24	14.82	457.6	51.7	3,543	400	4,429	500	8,858	1,000
PA721_0080 MFC	8.000	5,000	6,000	>24≤32	13.60	457.6	51.7	3,543	400	4,429	500	8,858	1,000
PA721_0080 MFC	8.000	5,000	6,000	>32≤38	15.20	457.6	51.7	3,543	400	4,429	500	8,858	1,000
PA721_0080 MFL	8.000	3,300	6,000	>38≤48	14.77	463.4	52.3	3,543	400	4,429	500	8,858	1,000
PA721_0080 MFLC	8.000	5,000	6,000	>38≤48	30.63	463.4	52.3	3,543	400	4,429	500	8,858	1,000
PA721_0100 MF	10.00	3,300	6,000	≤24	12.15	431.8	48.7	2,657	300	4,429	500	8,858	1,000
PA721_0100 MF	10.00	3,300	6,000	>24≤32	12.15	431.8	48.7	2,657	300	4,429	500	8,858	1,000
PA721_0100 MF	10.00	3,300	6,000	>32≤38	12.15	431.8	48.7	2,657	300	4,429	500	8,858	1,000
PA721_0100 MFC	10.00	5,500	6,000	≤24	14.57	431.8	48.7	2,657	300	4,429	500	8,858	1,000
PA721_0100 MFC	10.00	5,500	6,000	>24≤32	13.36	431.8	48.7	2,657	300	4,429	500	8,858	1,000
PA721_0100 MFC	10.00	5,500	6,000	>32≤38	14.95	431.8	48.7	2,657	300	4,429	500	8,858	1,000
PA721_0100 MFL	10.00	3,300	6,000	>38≤48	14.52	435.1	49.1	2,657	300	4,429	500	8,858	1,000
PA721_0100 MFLC	10.00	5,500	6,000	>38≤48	30.38	435.1	49.1	2,657	300	4,429	500	8,858	1,000

PA722 with Motor Mounting Plate *Continued Next Page*

PA722_0120 MF	12.00	3,000	5,000	≤19	6.24	457.8	51.7	2,480	280	4,429	500	8,901	1,005
PA722_0120 MF	12.00	3,000	5,000	>19≤24	6.31	459.4	51.9	2,480	280	4,429	500	9,177	1,036
PA722_0120 MF	12.00	3,000	5,000	>24≤32	6.21	459.4	51.9	2,480	280	4,429	500	9,177	1,036
PA722_0120 MF	12.00	3,000	5,000	>32≤35	6.21	459.4	51.9	2,480	280	4,429	500	9,177	1,036
PA722_0120 MFC	12.00	4,000	6,000	≤19	7.15	457.8	51.7	2,480	280	4,429	500	8,901	1,005
PA722_0120 MFC	12.00	4,000	6,000	>19≤24	6.76	459.4	51.9	2,480	280	4,429	500	9,177	1,036
PA722_0120 MFC	12.00	4,000	6,000	>24≤32	6.64	459.4	51.9	2,480	280	4,429	500	9,177	1,036
PA722_0120 MFL	12.00	3,000	5,000	>32≤38	13.40	462.8	52.3	2,480	280	4,429	500	9,177	1,036
PA722_0120 MFLC	12.00	4,000	6,000	>32≤38	16.19	462.8	52.3	2,480	280	4,429	500	9,177	1,036
PA722_0160 MF	16.00	3,000	5,000	≤19	5.94	470.4	53.1	3,898	440	6,201	700	11,868	1,340
PA722_0160 MF	16.00	3,000	5,000	>19≤24	6.01	471.4	53.2	3,898	440	6,201	700	12,235	1,381
PA722_0160 MF	16.00	3,000	5,000	>24≤32	5.91	471.4	53.2	3,898	440	6,201	700	12,235	1,381
PA722_0160 MF	16.00	3,000	5,000	>32≤35	5.91	471.4	53.2	3,898	440	6,201	700	12,235	1,381
PA722_0160 MFC	16.00	4,500	6,000	≤19	6.85	470.4	53.1	3,898	440	6,201	700	11,868	1,340
PA722_0160 MFC	16.00	4,500	6,000	>19≤24	6.46	471.4	53.2	3,898	440	6,201	700	12,235	1,381
PA722_0160 MFC	16.00	4,500	6,000	>24≤32	6.34	471.4	53.2	3,898	440	6,201	700	12,235	1,381
PA722_0160 MFL	16.00	3,000	5,000	>32≤38	13.10	473.4	53.4	3,898	440	6,201	700	12,235	1,381
PA722_0160 MFLC	16.00	4,500	6,000	>32≤38	15.90	473.4	53.4	3,898	440	6,201	700	12,235	1,381
PA722_0200 MF	20.00	3,000	5,000	≤19	5.85	471.8	53.3	3,898	440	6,201	700	12,401	1,400
PA722_0200 MF	20.00	3,000	5,000	>19≤24	5.92	472.4	53.3	3,898	440	6,201	700	12,401	1,400
PA722_0200 MF	20.00	3,000	5,000	>24≤32	5.82	472.4	53.3	3,898	440	6,201	700	12,401	1,400
PA722_0200 MF	20.00	3,000	5,000	>32≤35	5.82	472.4	53.3	3,898	440	6,201	700	12,401	1,400
PA722_0200 MFC	20.00	4,500	6,000	≤19	6.76	471.8	53.3	3,898	440	6,201	700	12,401	1,400
PA722_0200 MFC	20.00	4,500	6,000	>19≤24	6.37	472.4	53.3	3,898	440	6,201	700	12,401	1,400
PA722_0200 MFC	20.00	4,500	6,000	>24≤32	6.25	472.4	53.3	3,898	440	6,201	700	12,401	1,400
PA722_0200 MFL	20.00	3,000	5,000	>32≤38	13.01	473.7	53.5	3,898	440	6,201	700	12,401	1,400
PA722_0200 MFLC	20.00	4,500	6,000	>32≤38	15.80	473.7	53.5	3,898	440	6,201	700	12,401	1,400

Index of Symbols: MF — Motor adapter with FlexiAdapt® coupling; L — Large Input; C — ServoCool

See Page 22 for Options and Part Number Configuration.



"PA" Series – Advanced ServoFit® Precision Planetary Gearhead Selection Data



Part Number (Gearhead + Input)	Exact Ratio i	Maximum Input Speed		Motor Shaft ØD ⁶ mm	Input ¹⁾ Inertia J ₁ kgcm ²	Torsional Stiffness per arcmin C ₂		Output Torque					
		Continuous RPM (n ₁)	Cyclic RPM (n ₁)			in.lbs.	Nm	Nominal ²⁾		Acceleration		Peak ³⁾	
								M _{2N}	M _{2B}	M _{2PEAK}	M _{2PEAK}		

PA722 with Motor Mounting Plate *Continued Next Page*

PA722_0250 MF	25.00	3,500	6,000	≤19	5.45	472.0	53.3	3,898	440	6,201	700	12,401	1,400
PA722_0250 MF	25.00	3,500	6,000	>19≤24	5.52	472.4	53.3	3,898	440	6,201	700	12,401	1,400
PA722_0250 MF	25.00	3,500	6,000	>24≤32	5.42	472.4	53.3	3,898	440	6,201	700	12,401	1,400
PA722_0250 MF	25.00	3,500	6,000	>32≤35	5.42	472.4	53.3	3,898	440	6,201	700	12,401	1,400
PA722_0250 MFC	25.00	5,000	6,000	≤19	6.36	472.0	53.3	3,898	440	6,201	700	12,401	1,400
PA722_0250 MFC	25.00	5,000	6,000	>19≤24	5.97	472.4	53.3	3,898	440	6,201	700	12,401	1,400
PA722_0250 MFC	25.00	5,000	6,000	>24≤32	5.85	472.4	53.3	3,898	440	6,201	700	12,401	1,400
PA722_0250 MFL	25.00	3,500	6,000	>32≤38	12.62	473.2	53.4	3,898	440	6,201	700	12,401	1,400
PA722_0250 MFLC	25.00	5,000	6,000	>32≤38	15.41	473.2	53.4	3,898	440	6,201	700	12,401	1,400
PA722_0280 MF	28.00	3,700	6,500	≤19	5.16	466.9	52.7	3,898	440	6,201	700	12,235	1,381
PA722_0280 MF	28.00	3,700	6,500	>19≤24	5.16	466.9	52.7	3,898	440	6,201	700	12,235	1,381
PA722_0280 MF	28.00	3,700	6,500	>24≤32	5.06	466.9	52.7	3,898	440	6,201	700	12,235	1,381
PA722_0280 MF	28.00	3,700	6,500	>32≤35	5.06	466.9	52.7	3,898	440	6,201	700	12,235	1,381
PA722_0280 MFC	28.00	5,000	6,500	≤19	6.07	466.9	52.7	3,898	440	6,201	700	12,235	1,381
PA722_0280 MFC	28.00	5,000	6,500	>19≤24	5.61	466.9	52.7	3,898	440	6,201	700	12,235	1,381
PA722_0280 MFC	28.00	5,000	6,500	>24≤32	5.49	466.9	52.7	3,898	440	6,201	700	12,235	1,381
PA722_0280 MFL	28.00	3,700	6,500	>32≤38	11.99	467.7	52.8	3,898	440	6,201	700	12,235	1,381
PA722_0280 MFLC	28.00	5,000	6,500	>32≤38	14.79	467.7	52.8	3,898	440	6,201	700	12,235	1,381
PA722_0320 MF	32.00	3,000	5,000	≤19	5.77	456.4	51.5	3,543	400	4,429	500	8,858	1,000
PA722_0320 MF	32.00	3,000	5,000	>19≤24	5.84	456.6	51.5	3,543	400	4,429	500	8,858	1,000
PA722_0320 MF	32.00	3,000	5,000	>24≤32	5.74	456.6	51.5	3,543	400	4,429	500	8,858	1,000
PA722_0320 MF	32.00	3,000	5,000	>32≤35	5.74	456.6	51.5	3,543	400	4,429	500	8,858	1,000
PA722_0320 MFC	32.00	4,500	5,000	≤19	6.68	456.4	51.5	3,543	400	4,429	500	8,858	1,000
PA722_0320 MFC	32.00	4,500	5,000	>19≤24	6.29	456.6	51.5	3,543	400	4,429	500	8,858	1,000
PA722_0320 MFC	32.00	4,500	5,000	>24≤32	6.17	456.6	51.5	3,543	400	4,429	500	8,858	1,000
PA722_0320 MFL	32.00	3,000	5,000	>32≤38	12.93	457.1	51.6	3,543	400	4,429	500	8,858	1,000
PA722_0320 MFLC	32.00	4,500	5,000	>32≤38	15.72	457.1	51.6	3,543	400	4,429	500	8,858	1,000
PA722_0350 MF	35.00	3,700	6,500	≤19	5.13	469.5	53.0	3,898	440	6,201	700	12,401	1,400
PA722_0350 MF	35.00	3,700	6,500	>19≤24	5.13	469.5	53.0	3,898	440	6,201	700	12,401	1,400
PA722_0350 MF	35.00	3,700	6,500	>24≤32	5.03	469.5	53.0	3,898	440	6,201	700	12,401	1,400
PA722_0350 MF	35.00	3,700	6,500	>32≤35	5.03	469.5	53.0	3,898	440	6,201	700	12,401	1,400
PA722_0350 MFC	35.00	5,000	6,500	≤19	6.04	469.5	53.0	3,898	440	6,201	700	12,401	1,400
PA722_0350 MFC	35.00	5,000	6,500	>19≤24	5.58	469.5	53.0	3,898	440	6,201	700	12,401	1,400
PA722_0350 MFC	35.00	5,000	6,500	>24≤32	5.46	469.5	53.0	3,898	440	6,201	700	12,401	1,400
PA722_0350 MFL	35.00	3,700	6,500	>32≤38	11.96	470.0	53.1	3,898	440	6,201	700	12,401	1,400
PA722_0350 MFLC	35.00	5,000	6,500	>32≤38	14.75	470.0	53.1	3,898	440	6,201	700	12,401	1,400
PA722_0400 MF	40.00	3,700	6,500	≤19	4.98	461.3	52.1	3,898	440	6,201	700	12,235	1,381
PA722_0400 MF	40.00	3,700	6,500	>19≤24	4.98	461.3	52.1	3,898	440	6,201	700	12,235	1,381
PA722_0400 MF	40.00	3,700	6,500	>24≤32	4.88	461.3	52.1	3,898	440	6,201	700	12,235	1,381
PA722_0400 MF	40.00	3,700	6,500	>32≤35	4.88	461.3	52.1	3,898	440	6,201	700	12,235	1,381
PA722_0400 MFC	40.00	5,500	6,500	≤19	5.90	461.3	52.1	3,898	440	6,201	700	12,235	1,381
PA722_0400 MFC	40.00	5,500	6,500	>19≤24	5.43	461.3	52.1	3,898	440	6,201	700	12,235	1,381
PA722_0400 MFC	40.00	5,500	6,500	>24≤32	5.31	461.3	52.1	3,898	440	6,201	700	12,235	1,381
PA722_0400 MFL	40.00	3,700	6,500	>32≤38	11.81	461.7	52.1	3,898	440	6,201	700	12,235	1,381
PA722_0400 MFLC	40.00	5,500	6,500	>32≤38	14.61	461.7	52.1	3,898	440	6,201	700	12,235	1,381
PA722_0500 MF	50.00	3,700	6,500	≤19	4.97	465.9	52.6	3,898	440	6,201	700	12,401	1,400
PA722_0500 MF	50.00	3,700	6,500	>19≤24	4.97	465.9	52.6	3,898	440	6,201	700	12,401	1,400
PA722_0500 MF	50.00	3,700	6,500	>24≤32	4.87	465.9	52.6	3,898	440	6,201	700	12,401	1,400
PA722_0500 MF	50.00	3,700	6,500	>32≤35	4.87	465.9	52.6	3,898	440	6,201	700	12,401	1,400
PA722_0500 MFC	50.00	5,500	6,500	≤19	5.88	465.9	52.6	3,898	440	6,201	700	12,401	1,400
PA722_0500 MFC	50.00	5,500	6,500	>19≤24	5.42	465.9	52.6	3,898	440	6,201	700	12,401	1,400
PA722_0500 MFC	50.00	5,500	6,500	>24≤32	5.30	465.9	52.6	3,898	440	6,201	700	12,401	1,400

¹⁾ Inertia based on maximum input. For lower inertia using smaller diameter input, contact STOBER.

²⁾ Based on input speed: n₁ = 2000 RPM

For torque at higher input speeds (M_{2Nx}) solve the formula, where n₁ = Actual Input Speed.

$$M_{2Nx} = \frac{M_{2N}}{\sqrt[3]{\frac{n_1}{2000}}}$$

³⁾ Maximum momentary torque for emergency stops or heavy shock load. Admissible stops per life of gearhead = 1,000 stops maximum.



"PA" Series – Advanced ServoFit® Precision Planetary Gearhead Selection Data



P
A

Part Number (Gearhead + Input)	Exact Ratio i	Maximum Input Speed		Motor Shaft øD ⁶ mm	Input ¹⁾ Inertia J ₁ kgcm ²	Torsional Stiffness per arcmin		Output Torque					
		Continuous RPM (n ₁)	Cyclic			C ₂	Nominal ²⁾		Acceleration		Peak ³⁾		
							M _{2N}	M _{2B}	M _{2PEAK}	M _{2PEAK}			
Gearhead					in.lbs.	Nm	in.lbs.	Nm	in.lbs.	Nm	in.lbs.	Nm	

PA722 with Motor Mounting Plate *Continued*

PA722_0500 MFL	50.00	3,700	6,500	>32≤38	11.80	466.1	52.6	3,898	440	6,201	700	12,401	1,400
PA722_0500 MFLC	50.00	5,500	6,500	>32≤38	14.59	466.1	52.6	3,898	440	6,201	700	12,401	1,400
PA722_0700 MF	70.00	3,700	6,500	≤19	4.96	466.0	52.6	3,898	440	5,758	650	11,127	1,256
PA722_0700 MF	70.00	3,700	6,500	>19≤24	4.96	466.0	52.6	3,898	440	5,758	650	11,127	1,256
PA722_0700 MF	70.00	3,700	6,500	>24≤32	4.86	466.0	52.6	3,898	440	5,758	650	11,127	1,256
PA722_0700 MF	70.00	3,700	6,500	>32≤35	4.86	466.0	52.6	3,898	440	5,758	650	11,127	1,256
PA722_0700 MFC	70.00	5,500	6,500	≤19	5.87	466.0	52.6	3,898	440	5,758	650	11,127	1,256
PA722_0700 MFC	70.00	5,500	6,500	>19≤24	5.41	466.0	52.6	3,898	440	5,758	650	11,127	1,256
PA722_0700 MFC	70.00	5,500	6,500	>24≤32	5.29	466.0	52.6	3,898	440	5,758	650	11,127	1,256
PA722_0700 MFL	70.00	3,700	6,500	>32≤38	11.79	466.1	52.6	3,898	440	5,758	650	11,127	1,256
PA722_0700 MFLC	70.00	5,500	6,500	>32≤38	14.58	466.1	52.6	3,898	440	5,758	650	11,127	1,256
PA722_1000 MF	100.0	3,700	6,500	≤19	4.95	429.8	48.5	2,657	300	4,429	500	8,858	1,000
PA722_1000 MF	100.0	3,700	6,500	>19≤24	4.95	429.8	48.5	2,657	300	4,429	500	8,858	1,000
PA722_1000 MF	100.0	3,700	6,500	>24≤32	4.85	429.8	48.5	2,657	300	4,429	500	8,858	1,000
PA722_1000 MF	100.0	3,700	6,500	>32≤35	4.85	429.8	48.5	2,657	300	4,429	500	8,858	1,000
PA722_1000 MFC	100.0	5,500	6,500	≤19	5.86	429.8	48.5	2,657	300	4,429	500	8,858	1,000
PA722_1000 MFC	100.0	5,500	6,500	>19≤24	5.40	429.8	48.5	2,657	300	4,429	500	8,858	1,000
PA722_1000 MFC	100.0	5,500	6,500	>24≤32	5.28	429.8	48.5	2,657	300	4,429	500	8,858	1,000
PA722_1000 MFL	100.0	3,700	6,500	>32≤38	11.78	429.9	48.5	2,657	300	4,429	500	8,858	1,000
PA722_1000 MFLC	100.0	5,500	6,500	>32≤38	14.58	429.9	48.5	2,657	300	4,429	500	8,858	1,000

PA821 with Motor Mounting Plate *Continued Next Page*

PA821_0030 MF	3.000	1,800	3,000	≤32	71.83	1,404.0	158.5	7,086	800	8,537	964	10,672	1,205
PA821_0030 MF	3.000	1,800	3,000	>32≤38	71.60	1,464.9	165.4	7,086	800	10,630	1,200	15,518	1,752
PA821_0030 MF	3.000	1,800	3,000	>38≤48	70.97	1,464.9	165.4	7,086	800	10,630	1,200	17,064	1,926
PA821_0030 MFC	3.000	3,000	4,500	≤32	85.94	1,404.0	158.5	7,086	800	8,537	964	10,672	1,205
PA821_0030 MFC	3.000	3,000	4,500	>32≤38	87.71	1,464.9	165.4	7,086	800	10,630	1,200	15,518	1,752
PA821_0030 MFC	3.000	3,000	4,500	>38≤48	86.83	1,464.9	165.4	7,086	800	10,630	1,200	17,064	1,926
PA821_0040 MF	4.000	2,200	3,500	≤32	47.99	1,509.0	170.4	7,086	800	11,383	1,285	14,229	1,606
PA821_0040 MF	4.000	2,200	3,500	>32≤38	47.76	1,547.9	174.7	7,086	800	14,173	1,600	20,690	2,336
PA821_0040 MF	4.000	2,200	3,500	>38≤48	47.13	1,547.9	174.7	7,086	800	14,173	1,600	22,752	2,569
PA821_0040 MFC	4.000	3,200	5,000	≤32	62.10	1,509.0	170.4	7,086	800	11,383	1,285	14,229	1,606
PA821_0040 MFC	4.000	3,200	5,000	>32≤38	63.86	1,547.9	174.7	7,086	800	14,173	1,600	20,690	2,336
PA821_0040 MFC	4.000	3,200	5,000	>38≤48	62.99	1,547.9	174.7	7,086	800	14,173	1,600	22,752	2,569
PA821_0050 MF	5.000	2,500	4,000	≤32	41.16	1,530.0	172.7	8,858	1,000	14,173	1,600	17,786	2,008
PA821_0050 MF	5.000	2,500	4,000	>32≤38	40.94	1,555.4	175.6	8,858	1,000	14,173	1,600	25,863	2,920
PA821_0050 MF	5.000	2,500	4,000	>38≤48	40.30	1,555.4	175.6	8,858	1,000	14,173	1,600	28,346	3,200
PA821_0050 MFC	5.000	3,750	6,000	≤32	55.28	1,530.0	172.7	8,858	1,000	14,173	1,600	17,786	2,008
PA821_0050 MFC	5.000	3,750	6,000	>32≤38	57.04	1,555.4	175.6	8,858	1,000	14,173	1,600	25,863	2,920
PA821_0050 MFC	5.000	3,750	6,000	>38≤48	56.16	1,555.4	175.6	8,858	1,000	14,173	1,600	28,346	3,200
PA821_0070 MF	7.000	2,800	4,500	≤32	36.48	1,478.9	167.0	8,858	1,000	12,401	1,400	24,900	2,811
PA821_0070 MF	7.000	2,800	4,500	>32≤38	36.28	1,478.9	167.0	8,858	1,000	12,401	1,400	24,900	2,811
PA821_0070 MF	7.000	2,800	4,500	>38≤48	35.64	1,478.9	167.0	8,858	1,000	12,401	1,400	24,900	2,811
PA821_0070 MFC	7.000	4,500	6,000	≤32	50.60	1,478.9	167.0	8,858	1,000	12,401	1,400	24,900	2,811
PA821_0070 MFC	7.000	4,500	6,000	>32≤38	52.38	1,478.9	167.0	8,858	1,000	12,401	1,400	24,900	2,811
PA821_0070 MFC	7.000	4,500	6,000	>38≤48	51.50	1,478.9	167.0	8,858	1,000	12,401	1,400	24,900	2,811
PA821_0080 MF	8.000	2,800	4,500	≤32	35.25	1,413.9	159.6	7,086	800	10,630	1,200	21,259	2,400
PA821_0080 MF	8.000	2,800	4,500	>32≤38	35.04	1,413.9	159.6	7,086	800	10,630	1,200	21,259	2,400
PA821_0080 MF	8.000	2,800	4,500	>38≤48	34.40	1,413.9	159.6	7,086	800	10,630	1,200	21,259	2,400
PA821_0080 MFC	8.000	5,000	6,000	≤32	49.36	1,413.9	159.6	7,086	800	10,630	1,200	21,259	2,400
PA821_0080 MFC	8.000	5,000	6,000	>32≤38	51.14	1,413.9	159.6	7,086	800	10,630	1,200	21,259	2,400
PA821_0080 MFC	8.000	5,000	6,000	>38≤48	50.26	1,413.9	159.6	7,086	800	10,630	1,200	21,259	2,400

Index of Symbols: MF — Motor adapter with FlexiAdapt® coupling; L — Large Input; C — ServoCool

See Page 22 for Options and Part Number Configuration.



"PA" Series – Advanced ServoFit® Precision Planetary Gearhead Selection Data



Part Number (Gearhead + Input)	Exact Ratio i	Maximum Input Speed		Motor Shaft øD ⁶ mm	Input ¹⁾ Inertia J ₁ kgcm ²	Torsional Stiffness per arcmin C ₂		Output Torque					
		Continuous RPM (n ₁)	Cyclic			in.lbs.	Nm	Nominal ²⁾		Acceleration		Peak ³⁾	
								M _{2N}	M _{2B}	M _{2PEAK}	M _{2PEAK}		

PA821 with Motor Mounting Plate *Continued*

PA821_0100 MF	10.00	2,800	4,500	≤32	34.08	1,323.1	149.4	6,201	700	10,630	1,200	21,259	2,400
PA821_0100 MF	10.00	2,800	4,500	>32≤38	33.87	1,323.1	149.4	6,201	700	10,630	1,200	21,259	2,400
PA821_0100 MF	10.00	2,800	4,500	>38≤48	33.24	1,323.1	149.4	6,201	700	10,630	1,200	21,259	2,400
PA821_0100 MFC	10.00	5,500	6,000	≤32	48.19	1,323.1	149.4	6,201	700	10,630	1,200	21,259	2,400
PA821_0100 MFC	10.00	5,500	6,000	>32≤38	49.97	1,323.1	149.4	6,201	700	10,630	1,200	21,259	2,400
PA821_0100 MFC	10.00	5,500	6,000	>38≤48	49.10	1,323.1	149.4	6,201	700	10,630	1,200	21,259	2,400

PA822 with Motor Mounting Plate *Continued Next Page*

PA822_0120 MF	12.00	2,500	4,500	≤24	17.25	1,339.2	151.2	7,086	800	10,630	1,200	18,503	2,089
PA822_0120 MF	12.00	2,500	4,500	>24≤32	17.58	1,348.1	152.2	7,086	800	10,630	1,200	21,781	2,459
PA822_0120 MF	12.00	2,500	4,500	>32≤38	17.58	1,348.1	152.2	7,086	800	10,630	1,200	21,781	2,459
PA822_0120 MFC	12.00	3,300	5,000	≤24	20.00	1,348.1	152.2	7,086	800	10,630	1,200	21,781	2,459
PA822_0120 MFC	12.00	3,300	5,000	>24≤32	18.78	1,348.1	152.2	7,086	800	10,630	1,200	21,781	2,459
PA822_0120 MFC	12.00	3,300	5,000	>32≤38	20.38	1,348.1	152.2	7,086	800	10,630	1,200	21,781	2,459
PA822_0120 MFL	12.00	2,500	4,500	>38≤48	19.60	1,364.6	154.1	7,086	800	10,630	1,200	21,781	2,459
PA822_0120 MFLC	12.00	3,300	5,000	>38≤48	35.46	1,364.6	154.1	7,086	800	10,630	1,200	21,781	2,459
PA822_0160 MF	16.00	2,500	4,500	≤24	15.76	1,466.1	165.5	7,086	800	14,173	1,600	24,670	2,785
PA822_0160 MF	16.00	2,500	4,500	>24≤32	16.09	1,472.1	166.2	7,086	800	14,173	1,600	28,346	3,200
PA822_0160 MF	16.00	2,500	4,500	>32≤38	16.09	1,472.1	166.2	7,086	800	14,173	1,600	28,346	3,200
PA822_0160 MFC	16.00	3,400	6,000	≤24	18.51	1,472.1	166.2	7,086	800	14,173	1,600	28,346	3,200
PA822_0160 MFC	16.00	3,400	6,000	>24≤32	17.29	1,472.1	166.2	7,086	800	14,173	1,600	28,346	3,200
PA822_0160 MFC	16.00	3,400	6,000	>32≤38	18.89	1,472.1	166.2	7,086	800	14,173	1,600	28,346	3,200
PA822_0160 MFL	16.00	2,500	4,500	>38≤48	18.11	1,483.1	167.4	7,086	800	14,173	1,600	28,346	3,200
PA822_0160 MFLC	16.00	3,400	6,000	>38≤48	33.97	1,483.1	167.4	7,086	800	14,173	1,600	28,346	3,200
PA822_0200 MF	20.00	2,500	4,500	≤24	15.33	1,501.5	169.5	8,858	1,000	14,173	1,600	28,346	3,200
PA822_0200 MF	20.00	2,500	4,500	>24≤32	15.66	1,505.5	170.0	8,858	1,000	14,173	1,600	28,346	3,200
PA822_0200 MF	20.00	2,500	4,500	>32≤38	15.66	1,505.5	170.0	8,858	1,000	14,173	1,600	28,346	3,200
PA822_0200 MFC	20.00	3,600	6,000	≤24	18.08	1,505.5	170.0	8,858	1,000	14,173	1,600	28,346	3,200
PA822_0200 MFC	20.00	3,600	6,000	>24≤32	16.87	1,505.5	170.0	8,858	1,000	14,173	1,600	28,346	3,200
PA822_0200 MFC	20.00	3,600	6,000	>32≤38	18.46	1,505.5	170.0	8,858	1,000	14,173	1,600	28,346	3,200
PA822_0200 MFL	20.00	2,500	4,500	>38≤48	17.68	1,512.9	170.8	8,858	1,000	14,173	1,600	28,346	3,200
PA822_0200 MFLC	20.00	3,600	6,000	>38≤48	33.54	1,512.9	170.8	8,858	1,000	14,173	1,600	28,346	3,200
PA822_0250 MF	25.00	3,000	5,500	≤24	13.94	1,501.3	169.5	8,858	1,000	14,173	1,600	28,346	3,200
PA822_0250 MF	25.00	3,000	5,500	>24≤32	14.28	1,503.8	169.8	8,858	1,000	14,173	1,600	28,346	3,200
PA822_0250 MF	25.00	3,000	5,500	>32≤38	14.28	1,503.8	169.8	8,858	1,000	14,173	1,600	28,346	3,200
PA822_0250 MFC	25.00	4,000	6,000	≤24	16.69	1,503.8	169.8	8,858	1,000	14,173	1,600	28,346	3,200
PA822_0250 MFC	25.00	4,000	6,000	>24≤32	15.48	1,503.8	169.8	8,858	1,000	14,173	1,600	28,346	3,200
PA822_0250 MFC	25.00	4,000	6,000	>32≤38	17.07	1,503.8	169.8	8,858	1,000	14,173	1,600	28,346	3,200
PA822_0250 MFL	25.00	3,000	5,500	>38≤48	16.29	1,508.5	170.3	8,858	1,000	14,173	1,600	28,346	3,200
PA822_0250 MFLC	25.00	4,000	6,000	>38≤48	32.15	1,508.5	170.3	8,858	1,000	14,173	1,600	28,346	3,200
PA822_0280 MF	28.00	3,300	6,000	≤24	12.92	1,463.1	165.2	7,086	800	14,173	1,600	28,346	3,200
PA822_0280 MF	28.00	3,300	6,000	>24≤32	12.92	1,463.1	165.2	7,086	800	14,173	1,600	28,346	3,200
PA822_0280 MF	28.00	3,300	6,000	>32≤38	12.92	1,463.1	165.2	7,086	800	14,173	1,600	28,346	3,200
PA822_0280 MFC	28.00	4,500	6,000	≤24	15.34	1,463.1	165.2	7,086	800	14,173	1,600	28,346	3,200
PA822_0280 MFC	28.00	4,500	6,000	>24≤32	14.12	1,463.1	165.2	7,086	800	14,173	1,600	28,346	3,200
PA822_0280 MFC	28.00	4,500	6,000	>32≤38	15.71	1,463.1	165.2	7,086	800	14,173	1,600	28,346	3,200
PA822_0280 MFL	28.00	3,300	6,000	>38≤48	15.29	1,467.9	165.7	7,086	800	14,173	1,600	28,346	3,200
PA822_0280 MFLC	28.00	4,500	6,000	>38≤48	31.15	1,467.9	165.7	7,086	800	14,173	1,600	28,346	3,200

¹⁾ Inertia based on maximum input. For lower inertia using smaller diameter input, contact STOBER.

²⁾ Based on input speed: n₁ = 2000 RPM

For torque at higher input speeds (M_{2NX}) solve the formula, where n₁ = Actual Input Speed.

$$M_{2NX} = \frac{M_{2N}}{\sqrt[3]{\frac{n_1}{2000}}}$$

³⁾ Maximum momentary torque for emergency stops or heavy shock load. Admissible stops per life of gearhead = 1,000 stops maximum.



"PA" Series – Advanced ServoFit® Precision Planetary Gearhead Selection Data



P
A

Part Number (Gearhead + Input)	Exact Ratio i	Maximum Input Speed		Motor Shaft øD ⁶ mm	Input ¹⁾ Inertia J ₁ kgcm ²	Torsional Stiffness per arcmin		Output Torque					
		Continuous RPM (n ₁)	Cyclic RPM (n ₁)			C ₂		Nominal ²⁾		Acceleration		Peak ³⁾	
						in.lbs.	Nm	M _{2N}	Nm	M _{2B}	Nm	M _{2PEAK}	Nm
PA822_0320 MF	32.00	2,500	4,500	≤24	14.96	1,404.3	158.5	7,086	800	10,630	1,200	21,259	2,400
PA822_0320 MF	32.00	2,500	4,500	>24≤32	15.29	1,405.7	158.7	7,086	800	10,630	1,200	21,259	2,400
PA822_0320 MF	32.00	2,500	4,500	>32≤38	15.29	1,405.7	158.7	7,086	800	10,630	1,200	21,259	2,400
PA822_0320 MFC	32.00	3,600	6,000	≤24	17.71	1,405.7	158.7	7,086	800	10,630	1,200	21,259	2,400
PA822_0320 MFC	32.00	3,600	6,000	>24≤32	16.50	1,405.7	158.7	7,086	800	10,630	1,200	21,259	2,400
PA822_0320 MFC	32.00	3,600	6,000	>32≤38	18.09	1,405.7	158.7	7,086	800	10,630	1,200	21,259	2,400
PA822_0320 MFL	32.00	2,500	4,500	>38≤48	17.31	1,408.2	159.0	7,086	800	10,630	1,200	21,259	2,400
PA822_0320 MFLC	32.00	3,600	6,000	>38≤48	33.17	1,408.2	159.0	7,086	800	10,630	1,200	21,259	2,400
PA822_0350 MF	35.00	3,300	6,000	≤24	12.78	1,499.5	169.3	8,858	1,000	14,173	1,600	28,346	3,200
PA822_0350 MF	35.00	3,300	6,000	>24≤32	12.78	1,499.5	169.3	8,858	1,000	14,173	1,600	28,346	3,200
PA822_0350 MF	35.00	3,300	6,000	>32≤38	12.78	1,499.5	169.3	8,858	1,000	14,173	1,600	28,346	3,200
PA822_0350 MFC	35.00	4,500	6,000	≤24	15.20	1,499.5	169.3	8,858	1,000	14,173	1,600	28,346	3,200
PA822_0350 MFC	35.00	4,500	6,000	>24≤32	13.98	1,499.5	169.3	8,858	1,000	14,173	1,600	28,346	3,200
PA822_0350 MFC	35.00	4,500	6,000	>32≤38	15.58	1,499.5	169.3	8,858	1,000	14,173	1,600	28,346	3,200
PA822_0350 MFL	35.00	3,300	6,000	>38≤48	15.15	1,502.7	169.6	8,858	1,000	14,173	1,600	28,346	3,200
PA822_0350 MFLC	35.00	4,500	6,000	>38≤48	31.01	1,502.7	169.6	8,858	1,000	14,173	1,600	28,346	3,200
PA822_0400 MF	40.00	3,300	6,000	≤24	12.28	1,437.9	162.3	7,086	800	14,173	1,600	28,346	3,200
PA822_0400 MF	40.00	3,300	6,000	>24≤32	12.28	1,437.9	162.3	7,086	800	14,173	1,600	28,346	3,200
PA822_0400 MF	40.00	3,300	6,000	>32≤38	12.28	1,437.9	162.3	7,086	800	14,173	1,600	28,346	3,200
PA822_0400 MFC	40.00	5,000	6,000	≤24	14.70	1,437.9	162.3	7,086	800	14,173	1,600	28,346	3,200
PA822_0400 MFC	40.00	5,000	6,000	>24≤32	13.48	1,437.9	162.3	7,086	800	14,173	1,600	28,346	3,200
PA822_0400 MFC	40.00	5,000	6,000	>32≤38	15.08	1,437.9	162.3	7,086	800	14,173	1,600	28,346	3,200
PA822_0400 MFL	40.00	3,300	6,000	>38≤48	14.65	1,440.2	162.6	7,086	800	14,173	1,600	28,346	3,200
PA822_0400 MFLC	40.00	5,000	6,000	>38≤48	30.51	1,440.2	162.6	7,086	800	14,173	1,600	28,346	3,200
PA822_0500 MF	50.00	3,300	6,000	≤24	12.21	1,482.5	167.4	8,858	1,000	14,173	1,600	28,346	3,200
PA822_0500 MF	50.00	3,300	6,000	>24≤32	12.21	1,482.5	167.4	8,858	1,000	14,173	1,600	28,346	3,200
PA822_0500 MF	50.00	3,300	6,000	>32≤38	12.21	1,482.5	167.4	8,858	1,000	14,173	1,600	28,346	3,200
PA822_0500 MFC	50.00	5,000	6,000	≤24	14.63	1,482.5	167.4	8,858	1,000	14,173	1,600	28,346	3,200
PA822_0500 MFC	50.00	5,000	6,000	>24≤32	13.41	1,482.5	167.4	8,858	1,000	14,173	1,600	28,346	3,200
PA822_0500 MFC	50.00	5,000	6,000	>32≤38	15.01	1,482.5	167.4	8,858	1,000	14,173	1,600	28,346	3,200
PA822_0500 MFL	50.00	3,300	6,000	>38≤48	14.58	1,484.0	167.5	8,858	1,000	14,173	1,600	28,346	3,200
PA822_0500 MFLC	50.00	5,000	6,000	>38≤48	30.44	1,484.0	167.5	8,858	1,000	14,173	1,600	28,346	3,200
PA822_0700 MF	70.00	3,300	6,000	≤24	12.17	1,455.9	164.4	8,858	1,000	12,401	1,400	24,900	2,811
PA822_0700 MF	70.00	3,300	6,000	>24≤32	12.17	1,455.9	164.4	8,858	1,000	12,401	1,400	24,900	2,811
PA822_0700 MF	70.00	3,300	6,000	>32≤38	12.17	1,455.9	164.4	8,858	1,000	12,401	1,400	24,900	2,811
PA822_0700 MFC	70.00	5,000	6,000	≤24	14.58	1,455.9	164.4	8,858	1,000	12,401	1,400	24,900	2,811
PA822_0700 MFC	70.00	5,000	6,000	>24≤32	13.37	1,455.9	164.4	8,858	1,000	12,401	1,400	24,900	2,811
PA822_0700 MFC	70.00	5,000	6,000	>32≤38	14.96	1,455.9	164.4	8,858	1,000	12,401	1,400	24,900	2,811
PA822_0700 MFL	70.00	3,300	6,000	>38≤48	14.54	1,456.6	164.4	8,858	1,000	12,401	1,400	24,900	2,811
PA822_0700 MFLC	70.00	5,000	6,000	>38≤48	30.40	1,456.6	164.4	8,858	1,000	12,401	1,400	24,900	2,811
PA822_1000 MF	100.0	3,300	6,000	≤24	12.14	1,314.0	148.3	6,201	700	10,630	1,200	21,259	2,400
PA822_1000 MF	100.0	3,300	6,000	>24≤32	12.14	1,314.0	148.3	6,201	700	10,630	1,200	21,259	2,400
PA822_1000 MF	100.0	3,300	6,000	>32≤38	12.14	1,314.0	148.3	6,201	700	10,630	1,200	21,259	2,400
PA822_1000 MFC	100.0	5,000	6,000	≤24	14.56	1,314.0	148.3	6,201	700	10,630	1,200	21,259	2,400
PA822_1000 MFC	100.0	5,000	6,000	>24≤32	13.34	1,314.0	148.3	6,201	700	10,630	1,200	21,259	2,400
PA822_1000 MFC	100.0	5,000	6,000	>32≤38	14.94	1,314.0	148.3	6,201	700	10,630	1,200	21,259	2,400
PA822_1000 MFL	100.0	3,300	6,000	>38≤48	14.51	1,314.3	148.4	6,201	700	10,630	1,200	21,259	2,400
PA822_1000 MFLC	100.0	5,000	6,000	>38≤48	30.37	1,314.3	148.4	6,201	700	10,630	1,200	21,259	2,400

Index of Symbols: **MF** — Motor adapter with FlexiAdapt® coupling; **L** — Large Input; **C** — ServoCool

See Page 22 for Options and Part Number Configuration.



"PA" Series – Advanced ServoFit® Precision Planetary Gearhead Dimensional Data

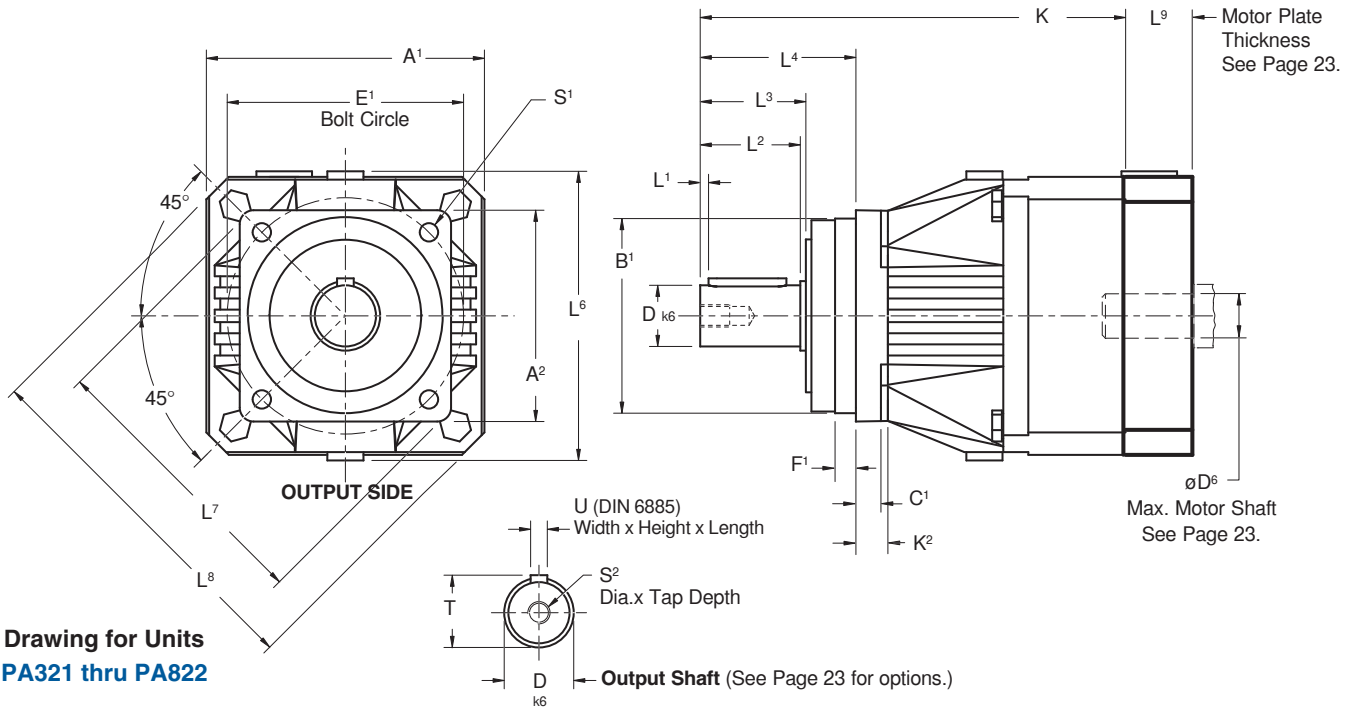

Drawing for Units PA321 thru PA822

Table No. 1 "PA" Series – Advanced Precision Planetary Gearhead Dimensions (mm)

Unit	A ¹	A ²	B ¹	h ₆	C ¹	D _{k6}	E ¹	F ¹	K ²	L ¹	L ²	L ³	L ⁴	L ⁶	L ⁷	L ⁸	S ¹	S ²	T	U
PA321/P322	72	72	60	+0.00/-0.019	7	16 +0.012/+0.001	75	7.5	—	2	28	30	48	79	92	92	5.5	M5x12.5	18	A5x5x22
PA421/P422	98	76	70	+0.00/-0.019	9	22 +0.015/+0.002	85	7.5	12	3	36	38	56	98	103.3	130	6.6	M8x19	24.5	A6x6x28
PA521/P522	115	101	90	+0.00/-0.022	10	32 +0.018/+0.002	120	15	14	3	58	60	88	121	139	149	9	M12x28	35	A10x8x50
PA721/P722	145	145	130	+0.00/-0.025	15	40 +0.018/+0.002	165	3.5	—	4	82	85	112	145	—	190	11	M16x36	43	A12x8x70
PA821/P822	190	190	160	+0.00/-0.025	15	55 +0.021/+0.002	215	10	—	6	82	85	112	190	—	250	13.5	M20x42	59	A16x10x70

Table No. 2

	K Dimension		
	Standard	ServoCool	
PA321	135	—	
PA322	158.5	—	
PA421	153	PA421_C	176.5
PA422	200.5	—	
PA521	193	PA521_C	221
PA522	242.5	PA522_C	266
PA721	242	PA721_C	272
PA722	294	PA722_C	322
PA821	283	PA821_C	331
PA822	350.5	PA822_C	380.5

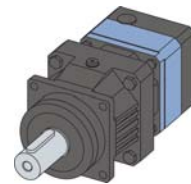

Typical 2 Stage Configuration

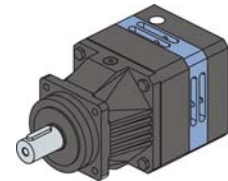

Typical ServoCool Configuration

Part No. Example
PA421SPD0030MFC



"PA" Series – Advanced – Large Input ServoFit® Precision Planetary Gearhead Dimensional Data



P
A

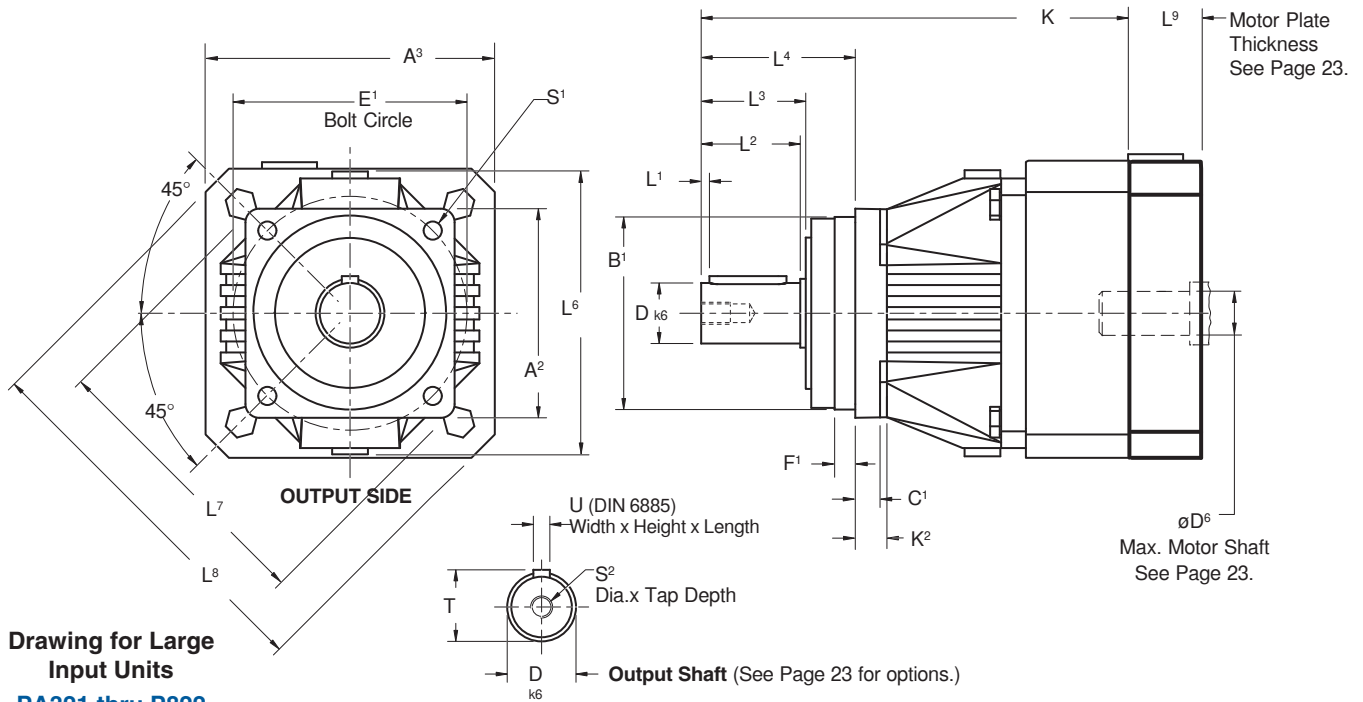

Drawing for Large
Input Units
PA321 thru P822

Table No. 1 "PA" Series – Large Input – Precision Planetary Gearhead Dimensions (mm)

Unit	A ²	B ¹ _{h6}	C ¹	D _{k6}	E ¹	F ¹	K ²	L ¹	L ²	L ³	L ⁴	L ⁶	L ⁷	S ¹	S ²	T	U
PA321/P322_L	72	60 +.000/-0.019	7	16 +.012/+0.001	75	7.5	—	2	28	30	48	130	92	5.5	M5x12.5	18	A5x5x22
PA421/P422_L	76	70 +.000/-0.019	9	22 +.015/+0.002	85	7.5	12	3	36	38	56	149	103.3	6.6	M8x19	24.5	A6x6x28
PA521/P522_L	101	90 +.000/-0.022	10	32 +.018/+0.002	120	15	14	3	58	60	88	190	139	9	M12x28	35	A10x8x50
PA721/P722_L	145	130 +.000/-0.025	15	40 +.018/+0.002	165	3.5	—	4	82	85	112	250	—	11	M16x36	43	A12x8x70
PA822_L	190	160 +.000/-0.025	15	55 +.021/+0.002	215	10	—	6	82	85	112	190	—	13.5	M20x42	59	A16x10x70

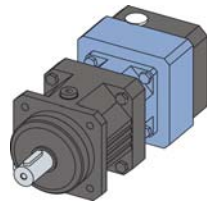

Typical 2 Stage Configuration
Large Input

Part No. Example
PA421SPD0030MFL

Table No. 2

Unit	A ³	K	L ⁸
PA321_L	100	138.3	130
PA421_L	115	161.5	149
PA422_L	100	203.8	130
PA521_L	145	207	190
PA522_L	115	251	149
PA721_L	190	259	250
PA722_L	145	308	190
PA822_L	190	367.5	250

See Page 22 for Options and Part Number Configuration.

"PKX" Series – Right Angle ServoFit® Precision Planetary Gearhead Performance Specification Overview



		P221 KX3	P222 KX3	P321 KX3	P322 KX3	P421 KX4	P422 KX3	P521 KX5	P522 KX4	P721 KX7	P722 KX5	P821 KX8	P822 KX7	P922 KX8
Acceleration Torque M _{2B} MAX	in.lbs.	195		576		1063		2,657		6,201		14,173		26,574
	Nm	22		65		120		300		700		1,600		3,000
Output Torque Nom. ¹⁾ M _{2N}	in.lbs.	142		399		753		1,860		3,898		8,858		17,716
	Nm	16		45		85		210		440		1,000		2,000
Input Speed Max. Continuous n ₁ MAX	Cyclic	3,500	3,500	3,500	3,500	3,000	3,500	3,000	3,000	2,100	3,000	1,300	2,100	1,300
		6,000	6,000	6,000	6,000	4,500	6,000	4,000	4,500	3,500	4,000	3,000	3,500	3,000
Torsional Backlash ²⁾ Δφ	arcmin	≤7 - 8.5		≤5 - 7.5		≤5 - 7.5		≤4 - 6.5		≤4 - 6.5		≤4 - 6.5		≤4 - 4.5
Torsional Stiffness C ₂	in.lbs./arcmin	17		44		100		266		486		1,557		3,016
	Nm/arcmin	1.9		5		11		33		55		176		340
Axial Load Maximum F _{2AMAX} ³⁾	R	lbs.	112	225	337	518	653	1,058	1,350					
		N	500	1,000	1,500	2,300	2,900	4,700	6,000					
	D	lbs.	—	315	506	788	1,013	1,688	2,250					
		N	—	1,400	2,250	3,500	4,500	7,500	10,000					
	Z	lbs.	—	135	225	360	450	810	1,125					
		N	—	600	1,000	1,600	2,000	3,600	5,000					
Radial Load Maximum ⁴⁾ F _{2RMAX} ³⁾	R	lbs.	270	563	900	1,463	1,800	2,925	4,050					
		N	1,200	2,500	4,000	6,500	8,000	13,000	18,000					
	D	lbs.	—	619	1,013	1,575	2,025	3,375	4,500					
		N	—	2,750	4,500	7,000	9,000	15,000	20,000					
	Z	lbs.	—	675	1,125	1,800	2,250	4,050	6,075					
		N	—	3,000	5,000	8,000	10,000	18,000	27,000					
Tilting Moment Maximum ⁴⁾ M _{2Kmax} ³⁾	R	in.lbs.	300	779	1,416	2,991	4,774	5,938	14,735					
		Nm	34	88	160	338	536	897	1,665					
	D	in.lbs.	—	929	1,717	3,593	5,735	10,089	18,320					
		Nm	—	105	194	406	648	1,140	2,070					
	Z	in.lbs.	—	929	1,770	3,682	5,929	10,992	22,125					
		Nm	—	105	200	416	670	1,242	2,500					
Weight m	pounds	7.3	8.6	8.8	101	15	16	28.5	25	51	47	105	95	181
	kg	3.3	3.9	4.0	4.6	6.8	7.0	12.8	11.3	23.2	21.3	47.4	43.2	82
Noise Level L _{PA}	dB(A) ⁵⁾	≤70		≤70		≤70		≤70 ≤72		≤72 ≤72		≤74 ≤72		≤74
Efficiency (at Nom. Torque) h	%	≥ 93% — 95%												
Balance Quality	Q 2.5 (Quality Class-2.5 millimeters per second)													
Lubrication	Synthetic Oil — Lubricated for Life													
Mounting Position	See Page 43.													
Degree of Protection	IP65 - FKM Shaft Seals													
Ambient Temperature	0° C to +40° C (104° F) [Unit temperature ≤ 90° C Max.]													
Finish	Black													
Lifetime ⁶⁾ L _h	hours	L _h > 10,000 hours if M _{2K} /M _{2A} < 1.25 and > 1.00												
		L _h > 20,000 hours if M _{2K} /M _{2A} > 1.25 and < 1.50												
		L _h > 30,000 hours if M _{2K} /M _{2A} > 1.5												
Warranty	5 Year Limited (2 Years on normal wear items: bearings, seals, etc.)													

¹⁾ Ratings based on input speed (n₁) of 2000 RPM.
For torque at higher input speeds (M_{2NX}) solve the formula, where n₁ = Actual Input Speed. $M_{2NX} = \frac{M_{2N}}{\sqrt[3]{\frac{n_1}{2000}}}$

²⁾ Tested at 1.5% of nominal torque and recorded on the output side of the gearhead.
For lower than standard backlash, contact STOBER Technical Support.

³⁾ See Page 44 for output bearing options.

⁴⁾ Rating based on output speed (n₂) of 100 RPM. For values at other speeds see Page 45.

⁵⁾ Measurement at one (1) meter distance with input speed (n₁) of 2000 RPM.

⁶⁾ M_{2A} equals actual tilting moment of the application. See Page 45 for calculation details.

WARNING: In order to insure that the specified torque ratings are attained, it is essential to attach the gear units to the machine with a grade 10.9 fastener.

Refer to Page 302 for ServoFit Precision Planetary Gearhead Selection Procedure.



"PKX" Series – Right Angle ServoFit® Precision Planetary Gearhead Features

The "PKX" Series ServoFit Precision Planetary Gearheads combines the "P" Series gearhead and a low ratio right angle which uses the FlexiAdapt® motor coupling. HeliCamber® gear technology provides minimum wear, low backlash, and low noise. "PKX" Series units are lubricated for life with synthetic oil and sealed to IP65 standards to prevent lubricant contamination for long life. They have all the great features of the "P" Series unit with the configuration of a right angle.

Some of these features are:

- Readily Attaches to Any Servo Motor (IEC, NEMA, or Customized Motor Plates*)
- 5 Year Limited Warranty (2 years on bearings, seals, etc.)
- Lowest Standard Backlash
- High Torsional Stiffness
- Advanced Gear Technology
- 93 to 95% Efficiency
- Quiet Running
- Assembled in the U.S.A.



* Maximum 10 working days for custom motor plates.

**NO EXPEDITE FEE FOR
24 HOUR SERVICE**

Highest running accuracy and precision ensured by single piece housing made from high-tensile tempered ductile iron with the additional characteristics of dissipating heat, noise dampening, and greater lubrication retention on the ring gear

Ring gear machined integral to the housing — not welded or pressed in — provides greater concentricity and eliminates speed fluctuation

Bearing options for application specific radial load, axial load, and tilting moments

FKM seals for the smallest possible diameter—reducing friction and heat buildup, increasing efficiency, and allowing continuous duty without additional cooling.

Planet carrier straddle mounted for robust output capacity

Highest running smoothness achieved by proven helical gearing and gear tooth microgeometry. Gear quality provided by case-hardened and finish-ground sun and planet gears.

Motor plate pilot toleranced to fit your motor for precise concentricity

Motor plate can easily be changed to fit your choice of motors

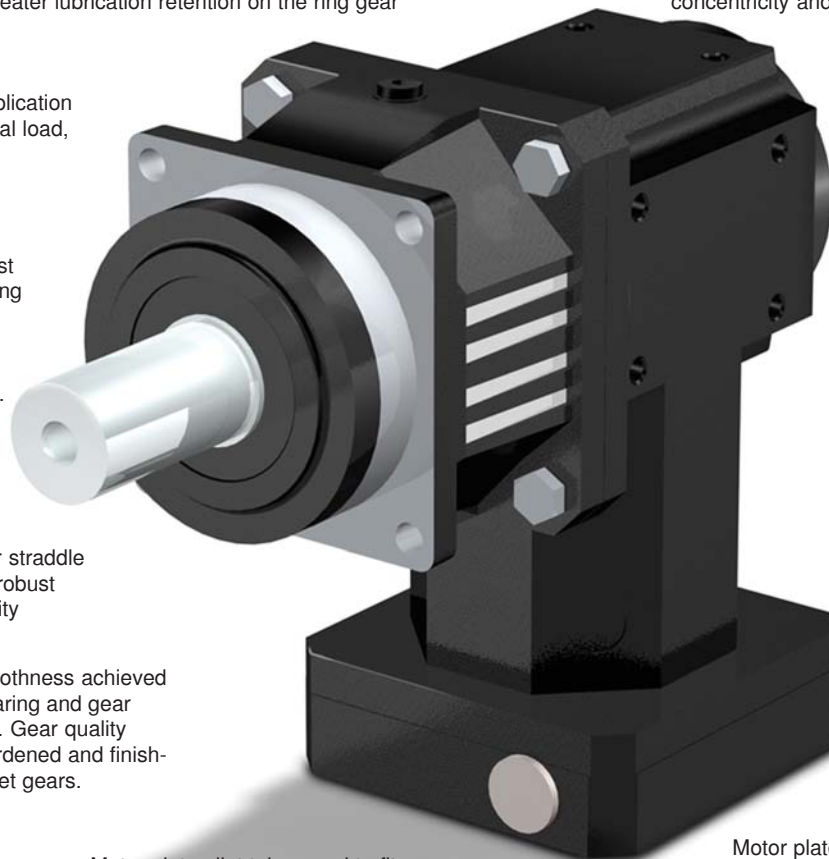

Magnetic oil filtration

Adapter bushings to fit all motor shafts — no key required

The FlexiAdapt® motor coupling is designed for accurate and precise motor installation. The integrated thermal expansion feature in the shape of a bellows compensates for linear expansion of the motor shaft.



The FlexiAdapt® motor shaft adapter system allows installation of motor in minutes without special tools.

"PKX" Series – Right Angle ServoFit® Precision Planetary Gearhead

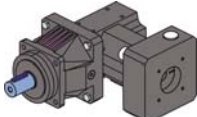

Part No. Explanation

P4 2 2 S P R 0250 KX301VF 0030 MF

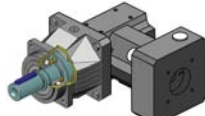
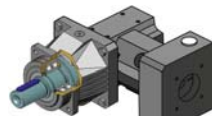
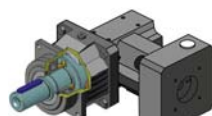
Series	Housing Option	Output Option	Bearing Option	Ratio	Right Angle	Ratio	Input
Planetary Series			P		Planetary Gearhead		
Size			4		2, 3, 4 , 5, 7, 8, 9		
Generation			2		First generation 0, second 1, etc.		
No. of Gear Stages			2		1, 2 (determined by the ratio)		
Housing Style			S		Standard		
Output Shaft			P		Shaft with Key		
			G		Plain Shaft (no key)		
Bearing Option			R		Normal Bearing		
			D		Reinforced Bearing (axial)		
			Z		Reinforced Bearing (radial)		
Ratio			0250		Approximate: 0250 = 25.00:1 (range of 3:1 up to 100:1)		
Secondary Unit			KX301VF		Right Angle Unit, Size 3, 1 Stage, with shaft and flange		
Ratio			0030		Approximate: 0030 = 3.00:1 (range of 1:1 up to 3:1)		
Motor Adapter			MF		FlexiAdapt® Motor Adapter (Motor information must be specified.)		



"PKX" Series – Right Angle ServoFit® Precision Planetary Gearhead

Mounting Position

Mount in ANY Horizontal Position – EL1, EL2, EL5, and EL6
Vertical Mounting Position – EL3 and EL4 – MUST BE SPECIFIED

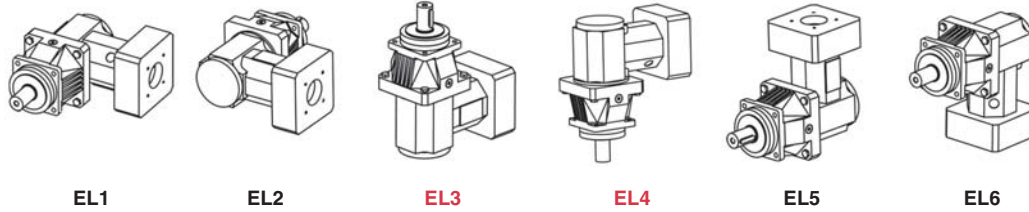

Motor Mounting Specifications

STOBER ServoFit Gearheads will fit the motor of your choice by assembling the correct motor mounting plate between the motor and the gearhead. **When ordering a gearhead, specify the motor manufacturer and part number, provide the motor drawing with dimensions, or specify the motor mounting dimensions.** The motor plate thickness (L^9) will be determined by the motor shaft length. The minimum motor plate thickness is shown below. For a precise dimension on a specific motor, contact STOBER Technical Support.

The following dimensions are required to provide the correct motor mounting plate:

1. D^6 Motor Shaft Diameter (If an adapter bushing is required it will be supplied with the motor plate.)
2. D^7 Pilot Diameter
3. D^8 Bolt Circle Diameter
4. D^9 Bolt Diameter
5. L^{11} Motor Shaft Length
6. L^{12} Pilot Length
7. L^{14} Square Flange (Optional — motor plate will typically be made to match this dimension.)

Table No. 1

Motor Plate Dims.	Planetary Size					
	P221KX3 P222KX3	P321KX3 P422KX3	P421KX4 P522KX4	P521KX5 P722KX5	P721KX7 P822KX7	P821KX8
D^6 Max.	14	19	24	32	38	48
L^9 Min.	15	18	21	24	25	33

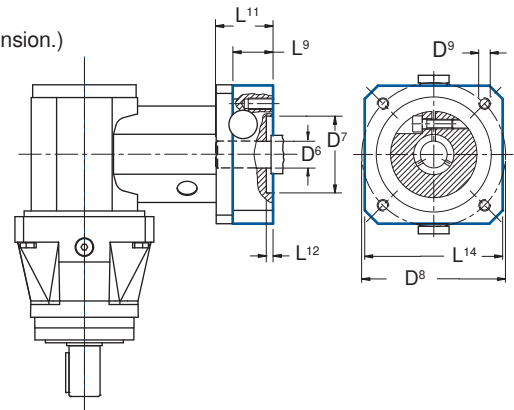

Direction of Rotation

P221KX301 – P521KX501
P222KX301 – P522KX401
P722KX501

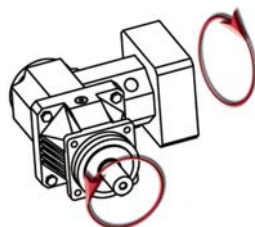

P721KX701 – P821KX801
P822KX701

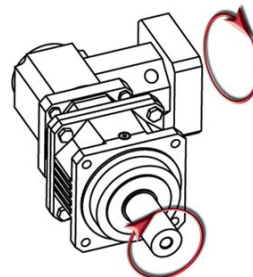

"PKX" Series – Right Angle ServoFit® Precision Planetary Gearhead Shaft Options



Output Shaft Options

The designation "P" or "G" for the output shaft must be included as part of the unit part number.

Table No. 1

P – Shaft with Key									
Unit No.	D k6 mm	L ¹ mm inches	L ² mm inches	L ⁴ mm inches	S ² (1)	T mm inches	U (2)	WDxHTxLG	
P3KX	16 +.012/+0.001	2 .08	28 1.10	48 1.89	M5	18 .71	A5x5x22		
P4KX	22 +.015/+0.002	3 .11	36 1.42	56 2.20	M8	24.5 .96	A6x6x28		
P5KX	32 +.018/+0.002	3 .11	58 2.28	88 3.46	M12	35 1.38	A10x8x50		
P7KX	40 +.018/+0.002	4 .16	82 3.23	112 4.41	M16	43 1.69	A12x8x70		
P8KX	55 +.021/+0.002	6 .24	82 3.23	112 4.41	M20	59 2.32	A16x10x70		

G – Shaft without Key					
Unit No.	D k6 mm	L ² mm inches	L ⁴ mm inches	S ³ (1)	
P3KX	16 +.012/+0.001	28 1.10	48 1.89	R4x8.5	
P4KX	22 +.015/+0.002	36 1.42	56 2.20	R4x8.5	
P5KX	32 +.018/+0.002	58 2.28	88 3.46	R4x8.5	
P7KX	40 +.018/+0.002	82 3.23	112 4.41	R4x8.5	
P8KX	55 +.021/+0.002	82 3.23	112 4.41	R5x10.6	

(1) The center hole in shafts with keys (Option "P") are machined to DIN 332 T2 shape DR.

(2) Feather keys are toleranced according to standard DIN 6885.

"P" – Shaft with Key

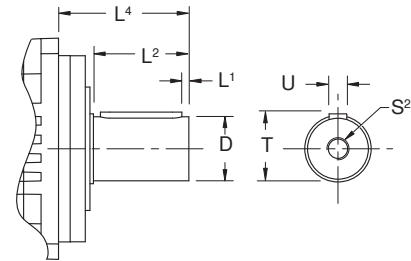

"G" – Shaft without Key

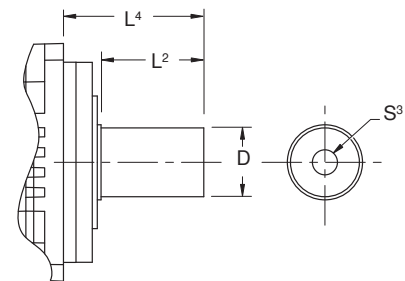

Output Bearing Options

"R" – Deep Groove Ball Bearing

Characteristics:

Minimal frictional torque
Good Radial load capacity
Axial load approx. 35% of radial load

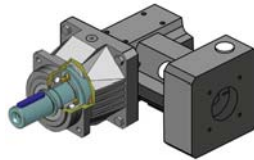

Applications:

Spur geared rack/pinion
Couplings
Belt with or without light tension

"D" – Double Row Angular Contact Ball Bearing

Characteristics:

Low frictional torque
Good radial bearing capacity
Axial load approx. 50% of radial load

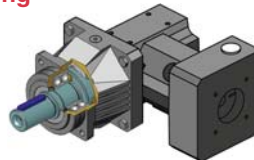

Applications:

Helical geared rack/pinion
Couplings with high axial load
Belt with or without light tension

"Z" – Cylindrical Roller Bearing

Characteristics:

Very good radial load capacity
Axial load approx. 20% of radial load

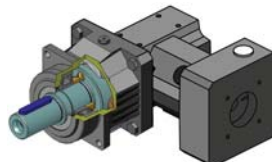

Applications:

Prestressed belt drive
Prestressed spur rack drive
Applications with high radial loads
and/or high service requirements



"PKX" Series – Right Angle ServoFit® Precision Planetary Gearhead Shaft Loads

The permissible load and tilting moment values are based on an output speed of 100 RPM. For higher speeds the following applies, where n_2 is the desired speed:

$$F_{2AX} = \frac{F_{2A}}{\sqrt[3]{\frac{n_2}{100}}} \quad F_{2RX} = \frac{F_{2R}}{\sqrt[3]{\frac{n_2}{100}}} \quad M_{2KX} = \frac{M_{2K}}{\sqrt[3]{\frac{n_2}{100}}}$$

The application input tilting moment should be determined by the following formula:

$$M_{2A} = \frac{2 \cdot F_{2a} \cdot y_2 + F_{2rb} \cdot (X_2 + Z_2)}{1000} \leq M_{2KB}$$

$$M_{2Ka} = \sqrt[3]{\frac{\Omega_{2b1} \cdot t_{b1} \cdot M_{2kb1}^3 + \dots + \Omega_{2bn} \cdot t_{bn} \cdot M_{2kbn}^3}{\Omega_{2b1} \cdot t_{b1} + \dots + \Omega_{2bn} \cdot t_{bn}}} \leq M_{2K}$$

$$F_{2r} = \sqrt[3]{\frac{\Omega_{2b1} \cdot t_{b1} \cdot F_{2rb1}^3 + \dots + \Omega_{2bn} \cdot t_{bn} \cdot F_{2rbn}^3}{\Omega_{2b1} \cdot t_{b1} + \dots + \Omega_{2bn} \cdot t_{bn}}} \leq F_{2R}$$

- where:
- F_{2a} Axial Load at Output Shaft
 - F_{2A} Permissible Axial Load
 - F_{2r} Radial Load at Output Shaft
 - F_{2R} Permissible Radial Load
 - F_{2RB} Acceleration Permissible Radial Load
 - M_{2K} Rated Tilting Torque
 - M_{2k} Equivalent Tilting Load
 - M_{2KB} Acceleration Tilting Torque
 - Z_2 Distance Factor

The hours of life (L_h) of the unit can be determined by the following formula:

bearing life for duty cycle $\leq 40\%$

- $L_h > 10,000$ hours if $M_{2k}/M_{2A} < 1.25$ and > 1
- $L_h > 20,000$ hours if $M_{2k}/M_{2A} > 1.25$ and > 1.5
- $L_h > 30,000$ hours if $M_{2k}/M_{2A} < 1.5$

bearing life for duty cycle $\geq 40\%$

$$L_{hA} = L_h \left(\frac{40\%}{\text{Duty Cycle}} \right)$$

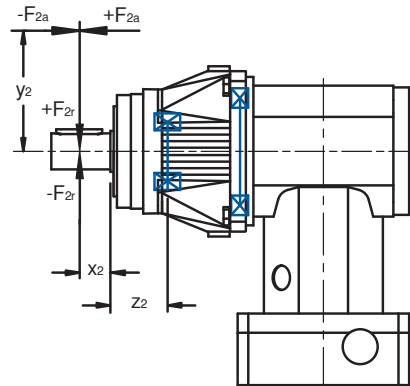

Table No. 1 Permissible Output Shaft Load and Tilting Moments

R – Output Bearing Option, Normal												
Unit No.	Z_2		F_{2A}		F_{2R}		F_{2RB}		M_{2K}		M_{2KB}	
	mm	inches	N	lbs.	N	lbs.	N	lbs.	Nm	in.lbs.	Nm	in.lbs.
P2KX	17	.669	500	112	1,200	270	1,300	293	34	300	36	319
P3KX	21	.827	1,000	225	2,500	563	2,500	563	88	779	88	779
P4KX	22	.866	1,500	337	4,000	900	4,500	1,013	160	1,416	180	1,593
P5KX	23	.906	2,300	518	6,500	1,463	7,000	1,575	338	2,708	364	3,221
P7KX	26	1.023	2,900	653	8,000	1,800	9,000	2,025	536	4,744	603	5,337
P8KX	28	1.102	4,700	1,058	13,000	2,925	18,000	4,050	897	7,938	1,242	10,992
P9KX	40	1.575	6,000	1,350	18,000	4,050	27,000	6,075	1,665	14,735	2,498	22,107

D – Output Bearing Option, Axially Reinforced												
Unit No.	Z_2		F_{2A}		F_{2R}		F_{2RB}		M_{2K}		M_{2KB}	
	mm	inches	N	lbs.	N	lbs.	N	lbs.	Nm	in.lbs.	Nm	in.lbs.
P3KX	24	.945	1,400	315	2,750	619	2,750	619	105	929	105	929
P4KX	25	.984	2,250	506	4,500	1,013	5,000	1,125	194	1,717	215	1,903
P5KX	29	1.142	3,500	788	7,000	1,575	8,000	1,800	406	3,593	464	4,106
P7KX	31	1.220	4,500	1,013	9,000	2,025	10,000	2,250	648	5,735	720	6,372
P8KX	35	1.378	7,500	1,688	15,000	3,375	18,000	4,050	1,140	10,089	1,368	12,107
P9KX	51	2.008	10,000	2,250	20,000	4,500	30,000	6,750	2,070	18,320	3,105	27,479

Z – Output Bearing Option, Radially Reinforced												
Unit No.	Z_2		F_{2A}		F_{2R}		F_{2RB}		M_{2K}		M_{2KB}	
	mm	inches	N	lbs.	N	lbs.	N	lbs.	Nm	in.lbs.	Nm	in.lbs.
P3KX	21	.83	600	135	3,000	675	3,000	675	105	929	105	929
P4KX	22	.87	1,000	225	5,000	1,125	5,000	1,125	200	1,770	200	1,770
P5KX	23	.91	1,600	360	8,000	1,800	8,000	1,800	416	3,682	416	3,682
P7KX	26	1.02	2,000	450	10,000	2,250	10,000	2,250	670	5,929	670	5,929
P8KX	28	1.10	3,600	810	18,000	4,050	18,000	4,050	1,242	10,992	1,242	10,992
P9KX	40	1.58	5,000	1,125	27,000	6,075	35,000	7,875	2,500	22,125	3,238	28,656

During EMERGENCY OFF operation (maximum stops per gearhead = 1000) the permissible values in the table for F_{2A} , F_{2R} , and M_{2K} can be multiplied by a factor of 2.

The permissible load values given are valid with the load applied to the center of the output shaft (x_2).



"PKX" Series – Right Angle ServoFit® Precision Planetary Gearhead Selection Data



Part Number (Gearhead + Input)	Exact Ratio i	Max. Input RPM (n ₁)			Max. Motor Shaft ØD ⁶ mm	Input Inertia J ₁ kgcm ²	Torsional Stiffness per arcmin C ₂		Output Torque					
		Continuous		Cyclic			Nominal ¹⁾		Acceleration		Peak ²⁾			
		Mounting Position					M _{2N}		M _{2B}		M _{2PEAK}			
		EL 1,2,5,6	EL 3,4	All			in.lbs.	Nm	in.lbs.	Nm	in.lbs.	Nm		

P221S_ _KX3 with Motor Mounting Plate

P221S_0040 KX301VF0010 MF	4.000	3,000	2,500	4,000	19	1.05	13.6	1.5	142	16	195	22	390	44
P221S_0050 KX301VF0010 MF	5.000	3,000	2,500	4,000	19	1.03	14.6	1.6	142	16	195	22	390	44
P221S_0070 KX301VF0010 MF	7.000	3,000	2,500	4,000	19	1.02	14.9	1.7	142	16	195	22	390	44
P221S_0040 KX301VF0020 MF	8.000	3,500	3,000	5,000	19	0.81	13.6	1.5	142	16	195	22	390	44
P221S_0050 KX301VF0020 MF	10.00	3,500	3,000	5,000	19	0.81	14.6	1.6	142	16	195	22	390	44
P221S_0050 KX301VF0030 MF	15.00	3,500	3,500	6,000	19	0.75	14.6	1.6	142	16	195	22	390	44
P221S_0100 KX301VF0020 MF	20.00	3,500	3,000	5,000	19	0.80	13.7	1.6	106	12	159	18	319	36
P221S_0070 KX301VF0030 MF	21.00	3,500	3,500	6,000	19	0.75	14.9	1.7	142	16	195	22	390	44
P221S_0080 KX301VF0030 MF	24.00	3,500	3,500	6,000	19	0.75	14.3	1.6	124	14	159	18	319	36
P221S_0100 KX301VF0030 MF	30.00	3,500	3,500	6,000	19	0.75	13.7	1.6	106	12	159	18	319	36

P222S_ _KX3 with Motor Mounting Plate

P222S_0350 KX301VF0010 MF	35.00	3,000	2,500	4,000	19	1.02	16.1	1.8	142	16	195	22	390	44
P222S_0200 KX301VF0020 MF	40.00	3,500	3,000	5,000	19	0.81	16.0	1.8	142	16	195	22	390	44
P222S_0250 KX301VF0020 MF	50.00	3,500	3,000	5,000	19	0.81	16.1	1.8	142	16	195	22	390	44
P222S_0280 KX301VF0020 MF	56.00	3,500	3,000	5,000	19	0.81	15.7	1.8	142	16	195	22	390	44
P222S_0200 KX301VF0030 MF	60.00	3,500	3,500	6,000	19	0.75	16.0	1.8	142	16	195	22	390	44
P222S_0350 KX301VF0020 MF	70.00	3,500	3,000	5,000	19	0.81	16.1	1.8	142	16	195	22	390	44
P222S_0250 KX301VF0030 MF	75.00	3,500	3,500	6,000	19	0.75	16.1	1.8	142	16	195	22	390	44
P222S_0400 KX301VF0020 MF	80.00	3,500	3,000	5,000	19	0.80	15.6	1.8	142	16	195	22	390	44
P222S_0280 KX301VF0030 MF	84.00	3,500	3,500	6,000	19	0.75	15.7	1.8	142	16	195	22	390	44
P222S_0500 KX301VF0020 MF	100.0	3,500	3,000	5,000	19	0.80	16.0	1.8	142	16	195	22	390	44
P222S_0350 KX301VF0030 MF	105.0	3,500	3,500	6,000	19	0.75	16.1	1.8	142	16	195	22	390	44
P222S_0400 KX301VF0030 MF	120.0	3,500	3,500	6,000	19	0.75	15.6	1.8	142	16	195	22	390	44
P222S_0700 KX301VF0020 MF	140.0	3,500	3,000	5,000	19	0.80	15.6	1.8	142	16	195	22	390	44
P222S_0500 KX301VF0030 MF	150.0	3,500	3,500	6,000	19	0.75	16.0	1.8	142	16	195	22	390	44
P222S_1000 KX301VF0020 MF	200.0	3,500	3,000	5,000	19	0.80	14.0	1.6	106	12	159	18	319	36
P222S_0700 KX301VF0030 MF	210.0	3,500	3,500	6,000	19	0.75	15.6	1.8	142	16	195	22	390	44
P222S_1000 KX301VF0030 MF	300.0	3,500	3,500	6,000	19	0.75	14.0	1.6	106	12	159	18	319	36

P321S_ _KX3 with Motor Mounting Plate

P321S_0030 KX301VF0010 MF	3.000	3,000	2,500	4,000	19	1.21	22.3	2.5	258	29	335	38	567	64
P321S_0040 KX301VF0010 MF	4.000	3,000	2,500	4,000	19	1.13	28.2	3.2	344	39	447	50	756	85
P321S_0050 KX301VF0010 MF	5.000	3,000	2,500	4,000	19	1.08	32.1	3.6	399	45	558	63	945	107
P321S_0030 KX301VF0020 MF	6.000	3,500	3,000	5,000	19	0.85	22.3	2.5	258	29	335	38	644	73
P321S_0070 KX301VF0010 MF	7.000	3,000	2,500	4,000	19	1.04	33.0	3.7	399	45	531	60	1,152	130
P321S_0040 KX301VF0020 MF	8.000	3,500	3,000	5,000	19	0.83	28.2	3.2	344	39	447	50	859	97
P321S_0050 KX301VF0020 MF	10.00	3,500	3,000	5,000	19	0.82	32.1	3.6	399	45	558	63	1,074	121
P321S_0050 KX301VF0030 MF	15.00	3,500	3,500	6,000	19	0.75	32.1	3.6	399	45	558	63	1,074	121
P321S_0100 KX301VF0020 MF	20.00	3,500	3,000	5,000	19	0.81	32.8	3.7	266	30	443	50	886	100
P321S_0070 KX301VF0030 MF	21.00	3,500	3,500	6,000	19	0.75	33.0	3.7	399	45	531	60	1,152	130
P321S_0080 KX301VF0030 MF	24.00	3,500	3,500	6,000	19	0.75	32.9	3.7	354	40	443	50	886	100
P321S_0100 KX301VF0030 MF	30.00	3,500	3,500	6,000	19	0.75	32.8	3.7	266	30	443	50	886	100

P322S_ _KX3 with Motor Mounting Plate Continued Next Page

P322S_0350 KX301VF0010 MF	35.00	3,000	2,500	4,000	19	1.02	40.3	4.5	399	45	576	65	1,152	130
P322S_0200 KX301VF0020 MF	40.00	3,500	3,000	5,000	19	0.81	39.9	4.5	399	45	576	65	1,152	130
P322S_0250 KX301VF0020 MF	50.00	3,500	3,000	5,000	19	0.81	40.2	4.5	399	45	576	65	1,152	130
P322S_0280 KX301VF0020 MF	56.00	3,500	3,000	5,000	19	0.81	39.2	4.4	399	45	576	65	1,152	130
P322S_0200 KX301VF0030 MF	60.00	3,500	3,500	6,000	19	0.75	39.9	4.5	399	45	576	65	1,152	130
P322S_0350 KX301VF0020 MF	70.00	3,500	3,000	5,000	19	0.81	40.3	4.5	399	45	576	65	1,152	130
P322S_0250 KX301VF0030 MF	75.00	3,500	3,500	6,000	19	0.75	40.2	4.5	399	45	576	65	1,152	130
P322S_0400 KX301VF0020 MF	80.00	3,500	3,000	5,000	19	0.80	38.7	4.4	399	45	576	65	1,152	130
P322S_0280 KX301VF0030 MF	84.00	3,500	3,500	6,000	19	0.75	39.2	4.4	399	45	576	65	1,152	130

¹⁾ Based on input speed: n₁ = 2000 RPM

For torque at higher input speeds (M_{2NX}) solve the formula, where n₁ = Actual Input Speed.
$$M_{2NX} = \frac{M_{2N}}{\sqrt[3]{\frac{n_1}{2000}}}$$

²⁾ Maximum momentary torque for emergency stops or heavy shock load. Admissible stops per life of gearhead = 1,000 stops maximum.



"PKX" Series – Right Angle ServoFit® Precision Planetary Gearhead Selection Data



PKX

Part Number (Gearhead + Input)	Exact Ratio i	Max. Input RPM (n ₁)			Max. Motor Shaft ØD ⁶ mm	Input Inertia J ₁ kgcm ²	Torsional Stiffness per arcmin C ₂		Output Torque					
		Continuous		Cyclic			Nominal ¹⁾		Acceleration		Peak ²⁾			
		Mounting Position					M _{2N}		M _{2B}		M _{2PEAK}			
		EL 1,2,5,6	EL 3,4	All			in.lbs.	Nm	in.lbs.	Nm	in.lbs.	Nm		

P322S_ _KX3 with Motor Mounting Plate Continued

P322S_ _0500 KX301VF0020 MF	100.0	3,500	3,000	5,000	19	0.80	39.9	4.5	399	45	576	65	1,152	130
P322S_ _0350 KX301VF0030 MF	105.0	3,500	3,500	6,000	19	0.75	40.3	4.5	399	45	576	65	1,152	130
P322S_ _0400 KX301VF0030 MF	120.0	3,500	3,500	6,000	19	0.75	38.7	4.4	399	45	576	65	1,152	130
P322S_ _0700 KX301VF0020 MF	140.0	3,500	3,000	5,000	19	0.80	36.8	4.2	399	45	531	60	1,152	130
P322S_ _0500 KX301VF0030 MF	150.0	3,500	3,500	6,000	19	0.75	39.9	4.5	399	45	576	65	1,152	130
P322S_ _1000 KX301VF0020 MF	200.0	3,500	3,000	5,000	19	0.80	34.5	3.9	266	30	443	50	886	100
P322S_ _0700 KX301VF0030 MF	210.0	3,500	3,500	6,000	19	0.75	36.8	4.2	399	45	531	60	1,152	130
P322S_ _1000 KX301VF0030 MF	300.0	3,500	3,500	6,000	19	0.75	34.5	3.9	266	30	443	50	886	100

P421S_ _KX4 with Motor Mounting Plate

P421S_ _0030 KX401VF0010 MF	3.000	2,500	2,000	3,500	24	3.05	46.4	5.2	443	50	644	73	1,289	146
P421S_ _0040 KX401VF0010 MF	4.000	2,500	2,000	3,500	24	2.65	60.7	6.9	687	78	859	97	1,718	194
P421S_ _0050 KX401VF0010 MF	5.000	2,500	2,000	3,500	24	2.55	70.6	8.0	753	85	1,063	120	2,126	240
P421S_ _0030 KX401VF0020 MF	6.000	2,500	2,500	4,000	24	1.79	46.4	5.2	443	50	644	73	1,289	146
P421S_ _0070 KX401VF0010 MF	7.000	2,500	2,000	3,500	24	2.44	74.2	8.4	753	85	974	110	2,126	240
P421S_ _0040 KX401VF0020 MF	8.000	2,500	2,500	4,000	24	1.70	60.7	6.9	687	78	859	97	1,718	194
P421S_ _0050 KX401VF0020 MF	10.00	2,500	2,500	4,000	24	1.67	70.6	8.0	753	85	1,063	120	2,126	240
P421S_ _0050 KX401VF0030 MF	15.00	3,000	3,000	4,500	24	1.45	70.6	8.0	753	85	1,063	120	2,126	240
P421S_ _0100 KX401VF0020 MF	20.00	2,500	2,500	4,000	24	1.63	73.1	8.3	531	60	886	100	1,772	200
P421S_ _0070 KX401VF0030 MF	21.00	3,000	3,000	4,500	24	1.44	74.2	8.4	753	85	974	110	2,126	240
P421S_ _0080 KX401VF0030 MF	24.00	3,000	3,000	4,500	24	1.44	73.3	8.3	709	80	886	100	1,772	200
P421S_ _0100 KX401VF0030 MF	30.00	3,000	3,000	4,500	24	1.44	73.1	8.3	531	60	886	100	1,772	200

P422S_ _KX3 with Motor Mounting Plate

P422S_ _0160 KX301VF0020 MF	32.00	3,500	3,000	5,000	19	0.84	86.0	9.7	753	85	1,063	120	2,126	240
P422S_ _0350 KX301VF0010 MF	35.00	3,000	2,500	4,000	19	1.05	92.1	10.4	753	85	1,063	120	2,126	240
P422S_ _0200 KX301VF0020 MF	40.00	3,500	3,000	5,000	19	0.84	90.4	10.2	753	85	1,063	120	2,126	240
P422S_ _0250 KX301VF0020 MF	50.00	3,500	3,000	5,000	19	0.82	91.8	10.4	753	85	1,063	120	2,126	240
P422S_ _0200 KX301VF0030 MF	60.00	3,500	3,500	6,000	19	0.76	90.4	10.2	753	85	1,063	120	2,126	240
P422S_ _0350 KX301VF0020 MF	70.00	3,500	3,000	5,000	19	0.81	92.1	10.4	753	85	1,063	120	2,126	240
P422S_ _0250 KX301VF0030 MF	75.00	3,500	3,500	6,000	19	0.75	91.8	10.4	753	85	1,063	120	2,126	240
P422S_ _0400 KX301VF0020 MF	80.00	3,500	3,000	5,000	19	0.81	88.4	10.0	753	85	1,063	120	2,126	240
P422S_ _0500 KX301VF0020 MF	100.0	3,500	3,000	5,000	19	0.81	92.0	10.4	753	85	1,063	120	2,126	240
P422S_ _0400 KX301VF0030 MF	120.0	3,500	3,500	6,000	19	0.75	88.4	10.0	753	85	1,063	120	2,126	240
P422S_ _0700 KX301VF0020 MF	140.0	3,500	3,000	5,000	19	0.81	84.7	9.6	753	85	974	110	2,126	240
P422S_ _0500 KX301VF0030 MF	150.0	3,500	3,500	6,000	19	0.75	92.0	10.4	753	85	1,063	120	2,126	240
P422S_ _1000 KX301VF0020 MF	200.0	3,500	3,000	5,000	19	0.81	77.8	8.8	531	60	886	100	1,772	200
P422S_ _0700 KX301VF0030 MF	210.0	3,500	3,500	6,000	19	0.75	84.7	9.6	753	85	974	110	2,126	240
P422S_ _1000 KX301VF0030 MF	300.0	3,500	3,500	6,000	19	0.75	77.8	8.8	531	60	886	100	1,772	200

P521S_ _KX5 with Motor Mounting Plate

P521S_ _0030 KX501VF0010 MF	3.000	2,500	2,000	3,000	32	8.73	120.0	13.5	1,063	120	1,624	183	3,222	364
P521S_ _0040 KX501VF0010 MF	4.000	2,500	2,000	3,000	32	8.52	154.9	17.5	1,718	194	2,165	244	4,296	485
P521S_ _0050 KX501VF0010 MF	5.000	2,500	2,000	3,000	32	8.11	181.4	20.5	1,860	210	2,657	300	5,315	600
P521S_ _0030 KX501VF0020 MF	6.000	2,500	2,500	3,500	32	5.59	120.0	13.5	1,063	120	1,624	183	3,222	364
P521S_ _0070 KX501VF0010 MF	7.000	2,500	2,000	3,000	32	7.74	200.3	22.6	1,860	210	2,392	270	5,315	600
P521S_ _0040 KX501VF0020 MF	8.000	2,500	2,500	3,500	32	5.54	154.9	17.5	1,718	194	2,165	244	4,296	485
P521S_ _0050 KX501VF0020 MF	10.00	2,500	2,500	3,500	32	5.43	181.4	20.5	1,860	210	2,657	300	5,315	600
P521S_ _0050 KX501VF0030 MF	15.00	3,000	3,000	4,000	32	4.85	181.4	20.5	1,860	210	2,657	300	5,315	600
P521S_ _0100 KX501VF0020 MF	20.00	2,500	2,500	3,500	32	5.31	200.6	22.6	1,240	140	2,215	250	4,429	500
P521S_ _0070 KX501VF0030 MF	21.00	3,000	3,000	4,000	32	4.81	200.3	22.6	1,860	210	2,392	270	5,315	600
P521S_ _0080 KX501VF0030 MF	24.00	3,000	3,000	4,000	32	4.80	197.0	22.2	1,772	200	2,215	250	4,429	500
P521S_ _0100 KX501VF0030 MF	30.00	3,000	3,000	4,000	32	4.79	200.6	22.6	1,240	140	2,215	250	4,429	500

Index of Symbols: MF — Motor adapter with FlexiAdapt® coupling; L — Large Input; C — ServoCool

See Page 42 for Options and Part Number Configuration.



"PKX" Series – Right Angle ServoFit® Precision Planetary Gearhead Selection Data



Part Number (Gearhead + Input)	Exact Ratio i	Max. Input RPM (n ₁)			Max. Motor Shaft ØD ⁶ mm	Input Inertia J ₁ kgcm ²	Torsional Stiffness per arcmin C ₂		Output Torque					
		Continuous	Cyclic	All					Nominal ¹⁾		Acceleration		Peak ²⁾	
		Mounting Position					M _{2N}		M _{2B}		M _{2PEAK}			
		EL 1,2,5,6	EL 3,4				in.lbs.	Nm	in.lbs.	Nm	in.lbs.	Nm	in.lbs.	Nm

P522S_ _KX4 with Motor Mounting Plate

P522S_0160 KX401VF0020 MF	32.00	2,500	2,500	4,000	24	1.71	220.0	24.8	1,860	210	2,657	300	4,915	555
P522S_0350 KX401VF0010 MF	35.00	2,500	2,000	3,500	24	2.46	239.9	27.1	1,860	210	2,657	300	5,315	600
P522S_0200 KX401VF0020 MF	40.00	2,500	2,500	4,000	24	1.70	233.2	26.3	1,860	210	2,657	300	5,315	600
P522S_0250 KX401VF0020 MF	50.00	2,500	2,500	4,000	24	1.67	238.3	26.9	1,860	210	2,657	300	5,315	600
P522S_0200 KX401VF0030 MF	60.00	3,000	3,000	4,500	24	1.47	233.2	26.3	1,860	210	2,657	300	5,315	600
P522S_0350 KX401VF0020 MF	70.00	2,500	2,500	4,000	24	1.65	239.9	27.1	1,860	210	2,657	300	5,315	600
P522S_0250 KX401VF0030 MF	75.00	3,000	3,000	4,500	24	1.46	238.3	26.9	1,860	210	2,657	300	5,315	600
P522S_0400 KX401VF0020 MF	80.00	2,500	2,500	4,000	24	1.64	228.8	25.8	1,860	210	2,657	300	4,915	555
P522S_0500 KX401VF0020 MF	100.0	2,500	2,500	4,000	24	1.64	239.4	27.0	1,860	210	2,657	300	5,315	600
P522S_0400 KX401VF0030 MF	120.0	3,000	3,000	4,500	24	1.44	228.8	25.8	1,860	210	2,657	300	4,915	555
P522S_0700 KX401VF0020 MF	140.0	2,500	2,500	4,000	24	1.63	232.0	26.2	1,860	210	2,392	270	5,315	600
P522S_0500 KX401VF0030 MF	150.0	3,000	3,000	4,500	24	1.44	239.4	27.0	1,860	210	2,657	300	5,315	600
P522S_1000 KX401VF0020 MF	200.0	2,500	2,500	4,000	24	1.63	214.9	24.3	1,240	140	2,215	250	4,429	500
P522S_0700 KX401VF0030 MF	210.0	3,000	3,000	4,500	24	1.44	232.0	26.2	1,860	210	2,392	270	5,315	600
P522S_1000 KX401VF0030 MF	300.0	3,000	3,000	4,500	24	1.44	214.9	24.3	1,240	140	2,215	250	4,429	500

P721S_ _KX7 with Motor Mounting Plate

P721S_0030 KX701VF0010 MF	3.000	1,800	1,600	2,250	38	33.17	325.7	36.8	2,480	280	3,186	360	5,671	640
P721S_0040 KX701VF0010 MF	4.000	1,800	1,600	2,250	38	28.45	381.1	43.0	3,437	388	4,296	485	7,561	854
P721S_0050 KX701VF0010 MF	5.000	1,800	1,600	2,250	38	26.92	410.1	46.3	3,898	440	5,370	606	9,451	1,067
P721S_0030 KX701VF0020 MF	6.000	1,800	1,800	3,000	38	16.79	325.7	36.8	2,480	280	3,186	360	6,444	728
P721S_0070 KX701VF0010 MF	7.000	1,800	1,600	2,250	38	25.92	435.7	49.2	3,898	440	5,758	650	11,127	1,256
P721S_0040 KX701VF0020 MF	8.000	1,800	1,800	3,000	38	15.61	381.1	43.0	3,437	388	4,296	485	8,592	970
P721S_0050 KX701VF0020 MF	10.00	1,800	1,800	3,000	38	15.23	410.1	46.3	3,898	440	5,370	606	10,740	1,213
P721S_0050 KX701VF0030 MF	15.00	2,100	2,100	3,500	38	12.65	410.1	46.3	3,898	440	5,370	606	10,740	1,213
P721S_0100 KX701VF0020 MF	20.00	1,800	1,800	3,000	38	14.85	416.8	47.0	2,657	300	4,429	500	8,858	1,000
P721S_0070 KX701VF0030 MF	21.00	2,100	2,100	3,500	38	12.54	435.7	49.2	3,898	440	5,758	650	11,127	1,256
P721S_0080 KX701VF0030 MF	24.00	2,100	2,100	3,500	38	12.51	431.8	48.8	3,543	400	4,429	500	8,858	1,000
P721S_0100 KX701VF0030 MF	30.00	2,100	2,100	3,500	38	12.48	416.8	47.0	2,657	300	4,429	500	8,858	1,000

P722S_ _KX5 with Motor Mounting Plate

P722S_0160 KX501VF0020 MF	32.00	2,500	2,500	3,500	32	5.56	437.6	49.4	3,898	440	6,201	700	12,235	1,381
P722S_0350 KX501VF0010 MF	35.00	2,500	2,000	3,000	32	7.80	462.3	52.2	3,898	440	6,201	700	12,401	1,400
P722S_0200 KX501VF0020 MF	40.00	2,500	2,500	3,500	32	5.53	450.1	50.8	3,898	440	6,201	700	12,401	1,400
P722S_0250 KX501VF0020 MF	50.00	2,500	2,500	3,500	32	5.43	457.9	51.7	3,898	440	6,201	700	12,401	1,400
P722S_0200 KX501VF0030 MF	60.00	3,000	3,000	4,000	32	4.89	450.1	50.8	3,898	440	6,201	700	12,401	1,400
P722S_0350 KX501VF0020 MF	70.00	2,500	2,500	3,500	32	5.35	462.3	52.2	3,898	440	6,201	700	12,401	1,400
P722S_0250 KX501VF0030 MF	75.00	3,000	3,000	4,000	32	4.85	457.9	51.7	3,898	440	6,201	700	12,401	1,400
P722S_0400 KX501VF0020 MF	80.00	2,500	2,500	3,500	32	5.32	456.0	51.5	3,898	440	6,201	700	12,235	1,381
P722S_0500 KX501VF0020 MF	100.0	2,500	2,500	3,500	32	5.31	462.4	52.2	3,898	440	6,201	700	12,401	1,400
P722S_0400 KX501VF0030 MF	120.0	3,000	3,000	4,000	32	4.80	456.0	51.5	3,898	440	6,201	700	12,235	1,381
P722S_0700 KX501VF0020 MF	140.0	2,500	2,500	3,500	32	5.31	464.2	52.4	3,898	440	5,758	650	11,127	1,256
P722S_0500 KX501VF0030 MF	150.0	3,000	3,000	4,000	32	4.79	462.4	52.2	3,898	440	6,201	700	12,401	1,400
P722S_1000 KX501VF0020 MF	200.0	2,500	2,500	3,500	32	5.31	429.1	48.4	2,657	300	4,429	500	8,858	1,000
P722S_0700 KX501VF0030 MF	210.0	3,000	3,000	4,000	32	4.79	464.2	52.4	3,898	440	5,758	650	11,127	1,256
P722S_1000 KX501VF0030 MF	300.0	3,000	3,000	4,000	32	4.79	429.1	48.4	2,657	300	4,429	500	8,858	1,000

¹⁾ Based on input speed: n₁ = 2000 RPM

For torque at higher input speeds (M_{2NX}) solve the formula, where n₁ = Actual Input Speed.
$$M_{2NX} = \frac{M_{2N}}{\sqrt[3]{\frac{n_1}{2000}}}$$

²⁾ Maximum momentary torque for emergency stops or heavy shock load. Admissible stops per life of gearhead = 1,000 stops maximum.



"PKX" Series – Right Angle ServoFit® Precision Planetary Gearhead Selection Data



PKX

Part Number (Gearhead + Input)	Exact Ratio i	Max. Input RPM (n ₁)			Max. Motor Shaft ØD ⁶ mm	Input Inertia J ₁ kgcm ²	Torsional Stiffness per arcmin C ₂		Output Torque					
		Continuous		Cyclic			Nominal ¹⁾		Acceleration		Peak ²⁾			
		Mounting Position					M _{2N}		M _{2B}		M _{2PEAK}			
		EL	EL	All			in.lbs.	Nm	in.lbs.	Nm	in.lbs.	Nm		
		1,2,5,6	3,4	All			in.lbs.	Nm	in.lbs.	Nm	in.lbs.	Nm		
P821S_ _KX8 with Motor Mounting Plate														
P821S_ _0030 KX801VF0010 MF	3.000	1,000	750	1,750	48	117.58	741.1	83.7	5,155	582	7,089	800	10,826	1,222
P821S_ _0040 KX801VF0010 MF	4.000	1,000	750	1,750	48	93.73	979.4	110.6	6,874	776	9,451	1,067	14,435	1,630
P821S_ _0050 KX801VF0010 MF	5.000	1,000	750	1,750	48	86.91	1132.5	127.9	8,592	970	11,814	1,334	18,044	2,037
P821S_ _0030 KX801VF0020 MF	6.000	1,100	1,100	2,500	48	58.98	741.1	83.7	5,155	582	7,089	800	12,888	1,455
P821S_ _0070 KX801VF0010 MF	7.000	1,000	750	1,750	48	82.23	1260.7	142.3	8,858	1,000	12,401	1,400	24,900	2,811
P821S_ _0040 KX801VF0020 MF	8.000	1,100	1,100	2,500	48	53.02	979.4	110.6	6,874	776	9,451	1,067	17,185	1,940
P821S_ _0050 KX801VF0020 MF	10.00	1,100	1,100	2,500	48	51.31	1132.5	127.9	8,592	970	11,814	1,334	21,481	2,425
P821S_ _0050 KX801VF0030 MF	15.00	1,300	1,300	3,000	48	44.31	1132.5	127.9	8,592	970	11,814	1,334	21,481	2,425
P821S_ _0100 KX801VF0020 MF	20.00	1,100	1,100	2,500	48	49.54	1229.8	138.8	6,201	700	10,630	1,200	21,259	2,400
P821S_ _0070 KX801VF0030 MF	21.00	1,300	1,300	3,000	48	43.79	1260.7	142.3	8,858	1,000	12,401	1,400	24,900	2,811
P821S_ _0080 KX801VF0030 MF	24.00	1,300	1,300	3,000	48	43.65	1254.9	141.7	7,086	800	10,630	1,200	21,259	2,400
P821S_ _0100 KX801VF0030 MF	30.00	1,300	1,300	3,000	48	43.52	1229.8	138.8	6,201	700	10,630	1,200	21,259	2,400
P822S_ _KX7 with Motor Mounting Plate														
P822S_ _0160 KX701VF0020 MF	32.00	1,800	1,800	3,000	38	15.75	1399.2	158.0	7,086	800	14,173	1,600	28,346	3,200
P822S_ _0350 KX701VF0010 MF	35.00	1,800	1,600	2,250	38	26.03	1484.3	167.6	8,858	1,000	14,173	1,600	28,346	3,200
P822S_ _0200 KX701VF0020 MF	40.00	1,800	1,800	3,000	38	15.64	1455.8	164.4	8,858	1,000	14,173	1,600	28,346	3,200
P822S_ _0250 KX701VF0020 MF	50.00	1,800	1,800	3,000	38	15.30	1471.7	166.1	8,858	1,000	14,173	1,600	28,346	3,200
P822S_ _0200 KX701VF0030 MF	60.00	2,100	2,100	3,500	38	12.83	1455.8	164.4	8,858	1,000	14,173	1,600	28,346	3,200
P822S_ _0350 KX701VF0020 MF	70.00	1,800	1,800	3,000	38	15.01	1484.3	167.6	8,858	1,000	14,173	1,600	28,346	3,200
P822S_ _0250 KX701VF0030 MF	75.00	2,100	2,100	3,500	38	12.68	1471.7	166.1	8,858	1,000	14,173	1,600	28,346	3,200
P822S_ _0400 KX701VF0020 MF	80.00	1,800	1,800	3,000	38	14.88	1427.2	161.1	7,086	800	14,173	1,600	28,346	3,200
P822S_ _0500 KX701VF0020 MF	100.0	1,800	1,800	3,000	38	14.86	1475.1	166.5	8,858	1,000	14,173	1,600	28,346	3,200
P822S_ _0400 KX701VF0030 MF	120.0	2,100	2,100	3,500	38	12.49	1427.2	161.1	7,086	800	14,173	1,600	28,346	3,200
P822S_ _0700 KX701VF0020 MF	140.0	1,800	1,800	3,000	38	14.85	1452.3	163.9	8,858	1,000	12,401	1,400	24,900	2,811
P822S_ _0500 KX701VF0030 MF	150.0	2,100	2,100	3,500	38	12.49	1475.1	166.5	8,858	1,000	14,173	1,600	28,346	3,200
P822S_ _1000 KX701VF0020 MF	200.0	1,800	1,800	3,000	38	14.85	1312.6	148.2	6,201	700	10,630	1,200	21,259	2,400
P822S_ _0700 KX701VF0030 MF	210.0	2,100	2,100	3,500	38	12.48	1452.3	163.9	8,858	1,000	12,401	1,400	24,900	2,811
P822S_ _1000 KX701VF0030 MF	300.0	2,100	2,100	3,500	38	12.48	1312.6	148.2	6,201	700	10,630	1,200	21,259	2,400
P922S_ _KX8 with Motor Mounting Plate														
P922S_ _0160 KX801VF0020 MF	32.00	1,100	1,100	2,500	48	53.26	2770.8	312.8	17,716	2,000	26,574	3,000	53,148	6,000
P922S_ _0350 KX801VF0010 MF	35.00	1,000	750	1,750	48	82.45	2895.9	326.9	17,716	2,000	26,574	3,000	53,148	6,000
P922S_ _0200 KX801VF0020 MF	40.00	1,100	1,100	2,500	48	52.98	2821.4	318.5	17,716	2,000	26,574	3,000	53,148	6,000
P922S_ _0250 KX801VF0020 MF	50.00	1,100	1,100	2,500	48	51.41	2866.1	323.6	17,716	2,000	26,574	3,000	53,148	6,000
P922S_ _0200 KX801VF0030 MF	60.00	1,300	1,300	3,000	48	45.05	2821.4	318.5	17,716	2,000	26,574	3,000	53,148	6,000
P922S_ _0350 KX801VF0020 MF	70.00	1,100	1,100	2,500	48	50.19	2895.9	326.9	17,716	2,000	26,574	3,000	53,148	6,000
P922S_ _0250 KX801VF0030 MF	75.00	1,300	1,300	3,000	48	44.35	2866.1	323.6	17,716	2,000	26,574	3,000	53,148	6,000
P922S_ _0400 KX801VF0020 MF	80.00	1,100	1,100	2,500	48	49.53	2874.4	324.5	17,716	2,000	26,574	3,000	53,148	6,000
P922S_ _0500 KX801VF0020 MF	100.0	1,100	1,100	2,500	48	49.48	2889.2	326.2	17,716	2,000	26,574	3,000	53,148	6,000
P922S_ _0400 KX801VF0030 MF	120.0	1,300	1,300	3,000	48	43.51	2874.4	324.5	17,716	2,000	26,574	3,000	53,148	6,000
P922S_ _0700 KX801VF0020 MF	140.0	1,100	1,100	2,500	48	49.45	2787.9	314.7	17,716	2,000	23,917	2,700	47,833	5,400
P922S_ _0500 KX801VF0030 MF	150.0	1,300	1,300	3,000	48	43.49	2889.2	326.2	17,716	2,000	26,574	3,000	53,148	6,000
P922S_ _1000 KX801VF0020 MF	200.0	1,100	1,100	2,500	48	49.43	2260.7	255.2	12,401	1,400	17,716	2,000	35,432	4,000
P922S_ _0700 KX801VF0030 MF	210.0	1,300	1,300	3,000	48	43.48	2787.9	314.7	17,716	2,000	23,917	2,700	47,833	5,400
P922S_ _1000 KX801VF0030 MF	300.0	1,300	1,300	3,000	48	43.47	2260.7	255.2	12,401	1,400	17,716	2,000	35,432	4,000

Index of Symbols: MF — Motor adapter with FlexiAdapt® coupling; L — Large Input; C — ServoCool

See Page 42 for Options and Part Number Configuration.



"PKX" Series – Right Angle ServoFit® Precision Planetary Gearhead Dimensional Data

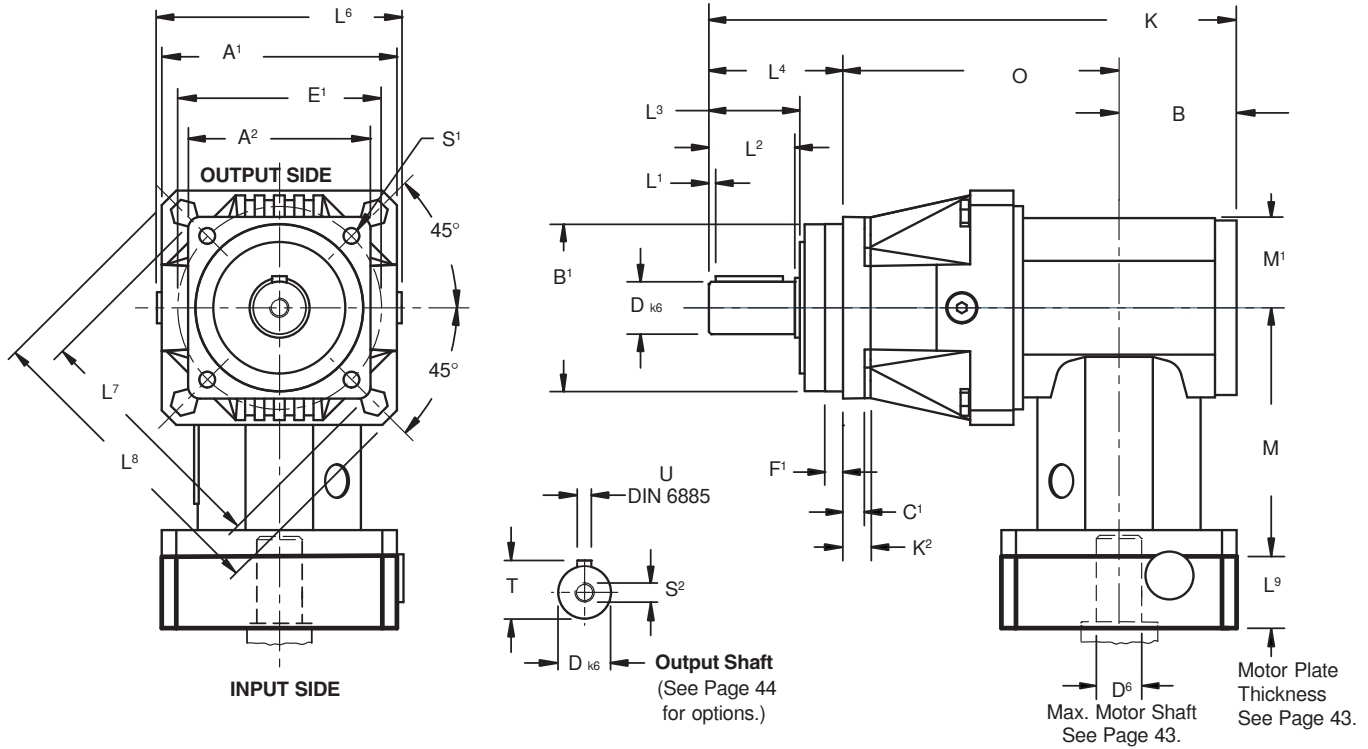

Table No. 1 "PKX" Series – ServoFit Precision Planetary Gearhead Dimensions (mm)

Unit	A ¹	A ²	B ¹ h ₆	C ¹	D k ₆	E ¹	F ¹	K ²	L ¹	L ²	L ³	L ⁴	L ⁶	L ⁷	L ⁸	S ¹	S ²	T	U
P221S_KX3	55	55	50 +.000/-0.016	6	12 +.012/+0.001	63	7.0	—	2	22	24	36	62	74	80	5.5	M4x13.5	13.5	A4x4x18
P321S_KX3	72	72	60 +.000/-0.019	7	16 +.012/+0.001	75	7.5	—	2	28	30	48	79	—	92	5.5	M5x12.5	18	A5x5x22
P421S_KX4	98	76	70 +.000/-0.019	9	22 +.015/+0.002	85	7.5	12	3	36	38	56	98	103.3	130	6.6	M8x19	24.5	A6x6x28
P521S_KX5	115	101	90 +.000/-0.022	10	32 +.018/+0.002	120	15	14	3	58	60	88	121	139	149	9	M12x28	35	A10x8x50
P721S_KX7	145	145	130 +.000/-0.025	15	40 +.018/+0.002	165	3.5	—	4	82	85	112	145	—	190	11	M16x36	43	A12x8x70
P821S_KX8	190	190	160 +.000/-0.025	15	55 +.021/+0.002	215	10	—	6	82	85	112	190	—	250	13.5	M20x42	59	A12x8x70

Table No. 2 Dimensions (mm)

Unit	B	K	M	M ¹	O
P221S_KX3	40	160	95.5	31	84
P321S_KX3	40	184	95.5	31	96
P421S_KX4	49	220	104	37.5	115
P521S_KX5	60	277	132	45	129
P721S_KX7	74	343	172.5	60	157
P821S_KX8	92	417	210	75	213

Part No. Example

P421SPR0100KX401VF 0030MF

Specify: Mounting Position
Paint, if not *Black*
Motor Information



"PKX" Series – Right Angle ServoFit® Precision Planetary Gearhead Dimensional Data



P
K
X

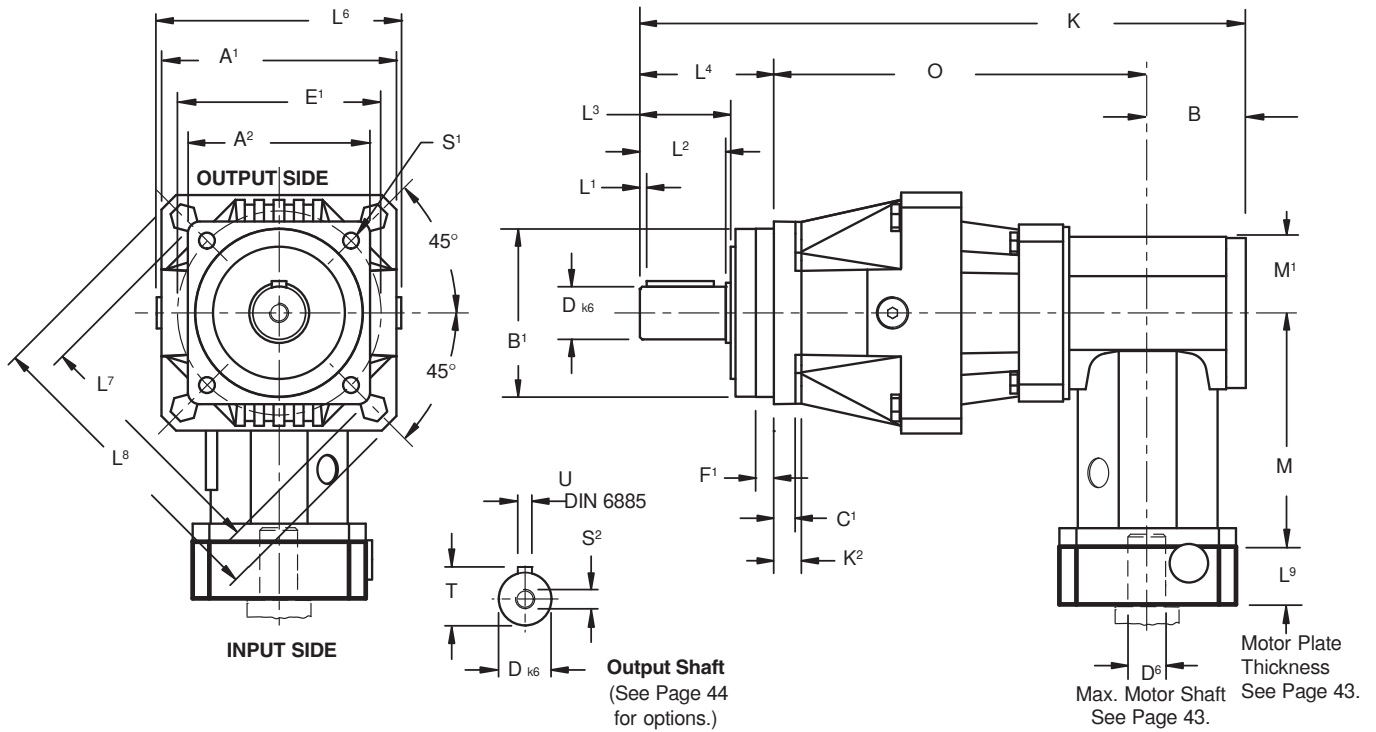

Table No. 3 "PKX" Series – ServoFit Precision Planetary Gearhead Dimensions (mm)

Unit	A ¹	A ²	B ¹ h ₆	C ¹	D _{k6}	E ¹	F ¹	K ²	L ¹	L ²	L ³	L ⁴	L ⁶	L ⁷	L ⁸	S ¹	S ²	T	U
P222S_KX3	55	55	50 +.000/- .016	6	12 +.012/+ .001	63	7.0	—	2	22	24	36	62	74	80	5.5	M4x13.5	13.5	A4x4x18
P322S_KX3	72	72	60 +.000/- .019	7	16 +.012/+ .001	75	7.5	—	2	28	30	48	79	92	92	5.5	M5x18	18	A5x5x22
P422S_KX3	98	76	70 +.000/- .019	9	22 +.015/+ .002	85	7.5	12	3	36	38	56	98	103.3	130	6.6	M8x19	24.5	A6x6x28
P522S_KX4	115	101	90 +.000/- .022	10	32 +.018/+ .002	120	15	14	3	58	60	88	121	139	149	9	M12x28	35	A10x8x50
P722S_KX5	145	145	130 +.000/- .025	15	40 +.018/+ .002	165	3.5	—	4	82	85	112	145	—	190	11	M16x36	43	A12x8x70
P822S_KX7	190	190	160 +.000/- .025	15	55 +.021/+ .002	215	10	—	6	82	85	112	190	—	250	13.5	M20x42	59	A16x10x70
P922S_KX8	225	212	180 +.000/- .025	17	75 +.021/+ .002	250	10	22	7	105	109	143	225	285	300	17.5	M20x42	79.5	A20x12x90

Table No. 4 Dimensions (mm)

Unit	B	K	M	M ¹	O
P222S_KX3	40	192	95.5	31	116
P322S_KX3	40	224	95.5	31	136
P422S_KX3	40	249.5	95.5	31	153.5
P522S_KX4	49	309.5	104	37.5	172.5
P722S_KX5	60	378	132	45	206
P822S_KX7	74	451.5	172.5	60	265.5
P922S_KX8	92	575	210	75	340

See Page 42 for Options and Part Number Configuration.

"PK" Series – Right Angle ServoFit® Precision Planetary Gearhead Performance Specification Overview



Size		P5_K1	P7_K1	P7_K2	P8_K2	P8_K3	P9_K4	
Acceleration Torque M _{2B} MAX	in.lbs.	2,655	5,752	6,195	12,390	14,160	23,895	
	Nm	300	650	700	1,400	1,600	2,700	
Output Torque Nom. M _{2N}	in.lbs.	1,860	3,898	3,898	8,850	8,850	17,700	
	Nm	210	440	440	1,000	1,000	2,000	
Input Speed Max. n ₁ MAX	Continuous	4,000	4,000	4,000	4,000	3,500	3,500	
	Cyclic	6,000	6,000	5,500	5,500	5,000	5,000	
Torsional Backlash Max. ¹⁾ Δφ	arcmin	≤5	≤4	≤4.5	≤3.5	≤4.5	≤3.5	
Torsional Stiffness C ₂	in.lbs./arcmin Nm/arcmin	230 26	407 46	398 45	566 64	956 108	2,186 247	
Axial Load Maximum F _{2A} MAX ²⁾	R	lbs.	518	653	653	1,058	1,058	1,350
		N	2,300	2,900	2,900	4,700	4,700	6,000
	D	lbs.	788	1,013	1,013	1,688	1,688	2,250
		N	3,500	4,500	4,500	7,500	7,500	10,000
	Z	lbs.	360	450	450	810	810	1,125
		N	1,600	2,000	2,000	3,600	3,600	5,000
Radial Load Maximum ³⁾ F _{2R} MAX ²⁾	R	lbs.	1,463	1,800	1,800	2,925	2,925	4,050
		N	6,500	8,000	8,000	13,000	13,000	18,000
	D	lbs.	1,575	2,025	2,025	3,375	3,375	4,500
		N	7,000	9,000	9,000	15,000	15,000	20,000
	Z	lbs.	1,800	2,250	2,250	4,050	4,050	6,075
		N	8,000	10,000	10,000	18,000	18,000	27,000
Tilting Moment Maximum ³⁾ M _{2K} MAX ²⁾	R	in.lbs.	2,991	4,774	4,774	5,938	5,938	14,735
		Nm	338	536	536	897	897	1,665
	D	in.lbs.	3,593	5,735	5,735	10,089	10,089	18,320
		Nm	406	648	648	1,140	1,140	2,070
	Z	in.lbs.	3,682	5,929	5,929	10,992	10,992	22,125
		Nm	416	670	670	1,242	1,242	2,500
Weight m	pounds	49	59	82	110	121	213	
	kg	22.4	26.5	37	50	55	96.4	
Noise Level L _{PA}	dB(A) ⁵⁾	≤63	≤63	≤64	≤64	≤65	≤66	
Efficiency (at Nom. Torque) h	%	≥ 93% — 95%						
Lubrication	Synthetic Oil — Lubricated for Life							
Mounting	Mounting Position must be specified. See Page 55.							
Degree of Protection	IP65 - FKM Shaft Seals							
Ambient Temperature	0° C to +40°C (104° F) [Unit temperature ≤ 90° C Max.]							
Finish	Black							
Bearing Lifetime. ⁵⁾ L _h	hours	L _h > 10,000 hours if M _{2K} /M _{2A} < 1.25 and > 1.00 L _h > 20,000 hours if M _{2K} /M _{2A} > 1.25 and < 1.50 L _h > 30,000 hours if M _{2K} /M _{2A} > 1.5						
Warranty	5 Year Limited (2 Years on normal wear items: bearings, seals, etc.)							

- 1) Tested at 1.5% of nominal torque and recorded on the output side of the gearhead. For lower than standard backlash, contact STOBER Technical Support.
- 2) See Page 56 for output bearing options.
- 3) Rating based on output speed (n₂) of 100 RPM. For values at other speeds see Page 57.
- 4) Measurement at one (1) meter distance with input speed (n₁) of 2000 RPM.
- 5) M_{2A} equals actual tilting moment of the application. See Page 57 for calculation details.

Refer to Page 302 for ServoFit Precision Planetary Gearhead Selection Procedure.



"PK" Series – Right Angle ServoFit® Precision Planetary Gearhead Features

The "PK" Series ServoFit Precision Planetary Gearheads combines the "P" Series gearhead and the reduced backlash SMS "K" Series. These gear units have an input stage with ground helical gearing which makes for extremely quiet running. The ground spiral bevel gearset ensures the units to have extremely low backlash of ≤ 5 arcminutes.

Some other features are:

- Readily Attaches to Any Servo Motor (IEC, NEMA, or Customized Motor Plates*)
- 5 Year Limited Warranty (2 years on bearings, seals, etc.)
- Low Backlash
- High Input Speeds
- Ratios up to 561:1
- Advanced Gear Technology
- 93 to 95% Efficiency
- Quiet Running
- Compact
- Assembled in the U.S.A.

Ductile iron housing dissipates heat, dampens noise, and provides greater lubrication retention on the ring gear

The patented motor coupling is designed to allow thermal expansion of the motor shaft — ensuring long motor life by preventing thrust load on the motor bearings.

Ring gear machined integral to the housing — not welded or pressed in — provides greater concentricity and eliminates speed fluctuation

The motor shaft adapter system allows installation of motor in minutes — no special tools required

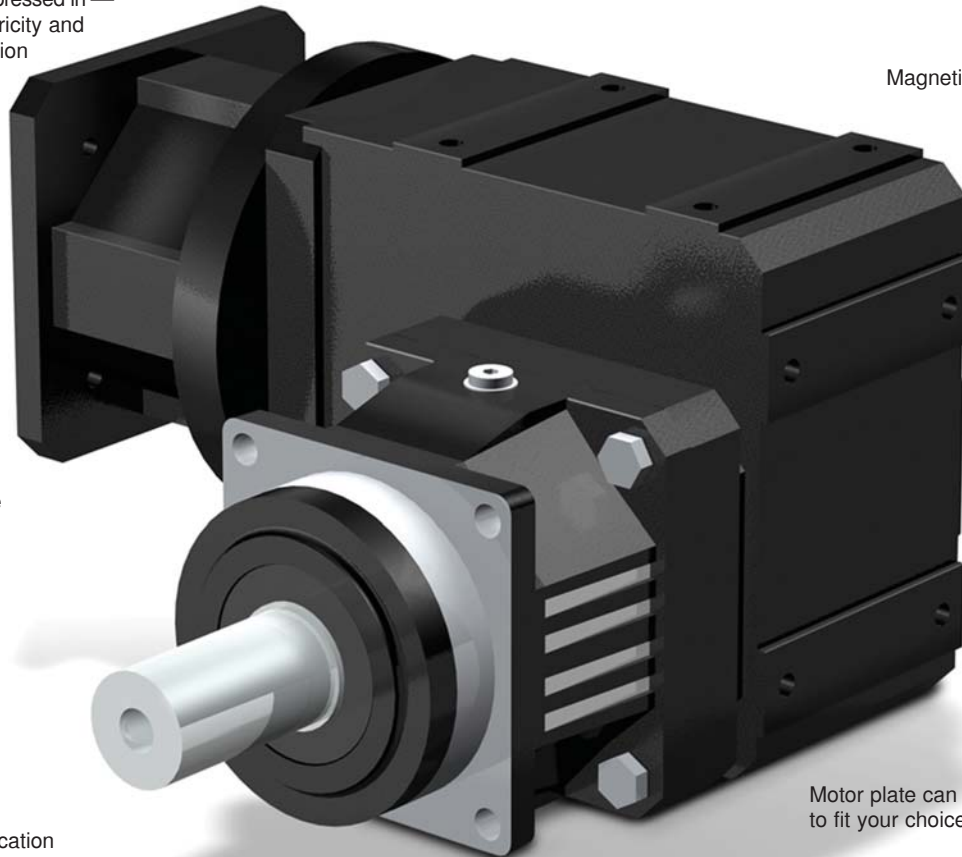

Magnetic oil filtration

Planet carrier straddle mounted for robust output capacity

Motor plate can easily be changed to fit your choice of motors

Bearing options for application specific radial load, axial load, and tilting moments

Motor plate pilot toleranced to fit your motor for precise concentricity

FKM seals for the smallest possible diameter—reducing friction and heat buildup, increasing efficiency, and allowing continuous duty without additional cooling.

Adapter bushings to fit all motor shafts — no key required



"PK" Series – Right Angle ServoFit® Precision Planetary Gearhead



Part No. Explanation

P 7 2 1 S P R 0050 K202VF 0060 MT30

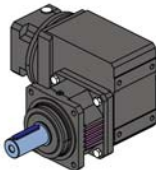
Series Size Generation No. of Gear Stages Housing Output Option Bearing Option Ratio Right Angle Unit Ratio Input

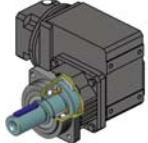
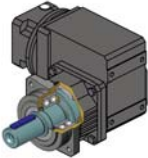
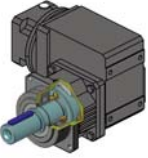
Series	P	Planetary Gearhead	
Size	7	5, 7, 8, 9	
Generation	2	First generation 0, second generation 1, etc.	
No. of Gear Stages	1	1 (determined by the ratio)	
Housing Style	S	Standard	
Output Shaft	P	Shaft with Key	
	G	Plain Shaft (no key)	
Bearing Option	R	Normal Bearing	
	D	Reinforced Bearing (axial)	
	Z	Reinforced Bearing (radial)	
Ratio	0050	Approximate: 0050 = 5.00:1 (range of 3:1 up to 10:1)	
Right Angle	K202VF	Series "K" Helical/Bevel, Size 202, with Output Shaft (V) and Flange (F)	
Ratio	0060	Approximate: 0060 = 6.00:1 (Planetary ratio × Right Angle ratio = Total 30:1)	
Motor Adapter	MT	TriAdapt® Motor Adapter (Motor information must be specified.)	



"PK" Series – Right Angle ServoFit® Precision Planetary Gearhead

Mounting Position

All ServoFit Precision Planetary units are filled with synthetic oil and lubricated for life. The units should never be opened or the oil changed. In order to provide the proper lubrication quantity, **the mounting position must be specified.**

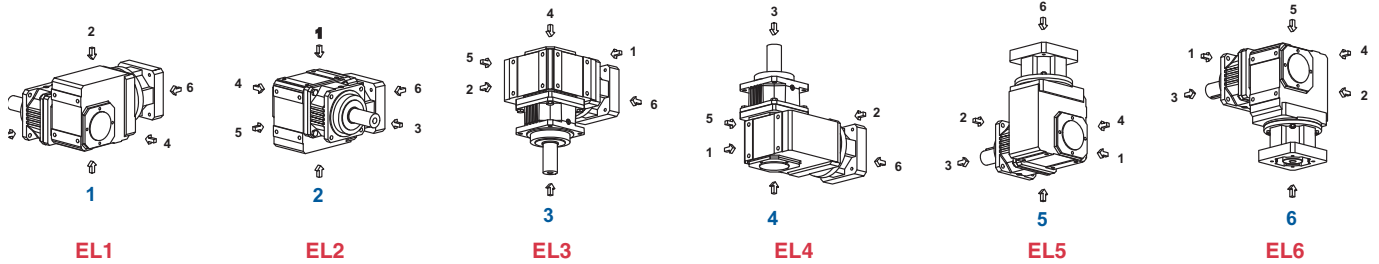

The "P" Series planetary unit can be mounted on the left (Side 4) or right (Side 3) of the "K" Series unit. **The mounting side must be specified.**

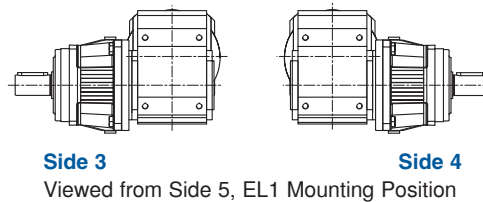

Motor Mounting Specifications

STOBER ServoFit Gearheads will fit the motor of your choice by assembling the correct motor mounting plate between the motor and the gearhead. **When ordering a gearhead, specify the motor manufacturer and part number, provide the motor drawing with dimensions, or specify the motor mounting dimensions.** The motor plate thickness (L^9) dimension will be determined by the motor shaft length. The minimum motor plate thickness is shown below. For a precise dimension on a specific motor, contact STOBER Technical Support.

The following dimensions are required to provide the correct motor mounting plate:

1. D^6 Motor Shaft Diameter (If an adapter bushing is required it will be supplied with the motor plate.)
2. D^7 Pilot Diameter
3. D^8 Bolt Circle Diameter
4. D^9 Bolt Diameter
5. L^{11} Motor Shaft Length
6. L^{12} Pilot Length
7. L^{14} Square Flange (Optional — Motor plate will typically be made to match.)

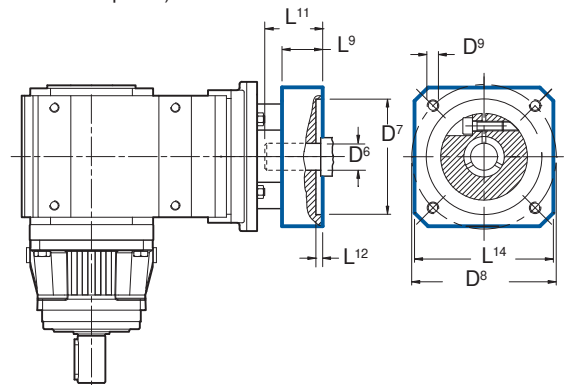
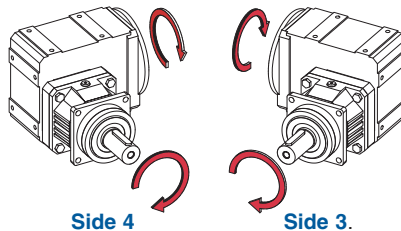

Table No.1

Input Option	Shaft D^6 Max.	Motor Plate Thickness L^9 Min.
MT10	19	21
MT20	24	24
MT30	38	25
MT40	48	33
MT50	60	43

Direction of Rotation



EL1 Mounting Position, CCW input, viewed from:

Maintenance

With STOBER reducers very little maintenance is required under normal operating conditions. Units supplied without breathers are lubricated for life. All units (K1 thru K4) in the PK Series do not have breathers.

"PK" Series – Right Angle ServoFit® Precision Planetary Gearhead



Output Shaft Options

The designation "P" or "G" for the output shaft must be included as part of the unit part number.

Table No. 1

P – Shaft with Key									
Unit No.	D k6 mm	L ¹ mm inches	L ² mm inches	L ⁴ mm inches	S ² (1)	T mm inches	U (2)		
P5K	32 +.018/+0.002	3 .11	58 2.28	88 3.46	M12	35 1.38	A10x8x50		
P7K	40 +.018/+0.002	4 .16	82 3.23	112 4.41	M16	43 1.69	A12x8x70		
P8K	55 +.021/+0.002	6 .24	82 3.23	112 4.41	M20	59 2.32	A16x10x70		
P9K	75 +.021/+0.002	7 .28	105 4.13	143 5.63	M20	79.5 3.13	A20x12x90		

G – Shaft without Key						
Unit No.	D k6 mm	L ² mm inches	L ⁴ mm inches	S ³ (1)		
P5K	32 +.018/+0.002	58 2.28	88 3.46	R4x8.5		
P7K	40 +.018/+0.002	82 3.23	112 4.41	R4x8.5		
P8K	55 +.021/+0.002	82 3.23	112 4.41	R5x10.6		
P9K	75 +.021/+0.002	105 4.13	143 5.63	M20		

(1) The center hole in shafts with keys (Option "P") are machined to DIN 332 T2 shape DR.
 (2) Feather keys are toleranced according to standard DIN 6885.

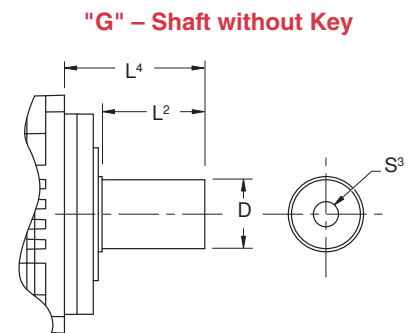
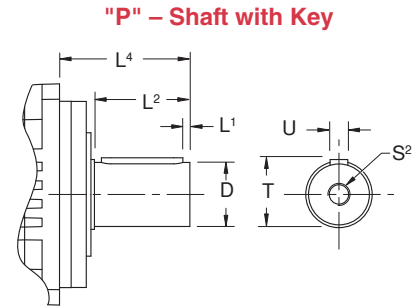

Output Bearing Options

"R" – Deep Groove Ball Bearing

Characteristics:

Minimal frictional torque
 Good Radial load capacity
 Axial load approx. 35% of radial load

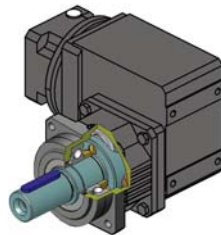

Applications:

Spur geared rack/pinion
 Couplings
 Belt with or without light tension

"D" – Double Row Angular Contact Ball Bearing

Characteristics:

Low frictional torque
 Good radial bearing capacity
 Axial load approx. 50% of radial load

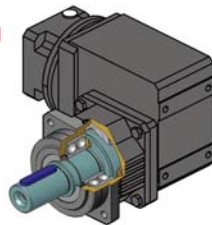

Applications:

Helical geared rack/pinion
 Couplings with high axial load
 Belt with or without light tension

"Z" – Cylindrical Roller Bearing

Characteristics:

Very good radial load capacity
 Axial load approx. 20% of radial load

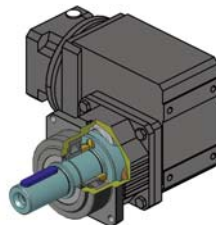

Applications:

Prestressed belt drive
 Prestressed spur rack drive
 Applications with high radial loads
 and/or high service requirements



"PK" Series – Right Angle ServoFit® Precision Planetary Gearhead Shaft Loads

Permissible Shaft Load and Tilting Moments

The permissible load and tilting moment values are based on an output speed of 100 RPM. For higher speeds the following applies, where n_2 is the desired speed:

$$F_{2AX} = \frac{F_{2A}}{\sqrt[3]{\frac{n_2}{100}}} \quad F_{2RX} = \frac{F_{2R}}{\sqrt[3]{\frac{n_2}{100}}} \quad M_{2KX} = \frac{M_{2K}}{\sqrt[3]{\frac{n_2}{100}}}$$

The application input tilting moment should be determined by the following formula:

$$M_{2A} = \frac{2 \cdot F_{2a} \cdot y_2 + F_{2rb} \cdot (x_2 + z_2)}{1000} \leq M_{2KB}$$

$$M_{2ka} = \sqrt[3]{\frac{n_{2b1} \cdot t_{b1} \cdot M_{2kb1}^3 + \dots + n_{2bn} \cdot t_{bn} \cdot M_{2kbn}^3}{n_{2b1} \cdot t_{b1} + \dots + n_{2bn} \cdot t_{bn}}} \leq M_{2K}$$

$$F_{2r} = \sqrt[3]{\frac{n_{2b1} \cdot t_{b1} \cdot F_{2rb1}^3 + \dots + n_{2bn} \cdot t_{bn} \cdot F_{2rbn}^3}{n_{2b1} \cdot t_{b1} + \dots + n_{2bn} \cdot t_{bn}}} \leq F_{2R}$$

- where:
- F_{2a} Axial Load at Output Shaft
 - F_{2A} Permissible Axial Load
 - F_{2r} Radial Load at Output Shaft
 - F_{2R} Permissible Radial Load
 - F_{2RB} Acceleration Permissible Radial Load
 - M_{2K} Rated Tilting Torque
 - M_{2k} Equivalent Tilting Load
 - M_{2KB} Acceleration Tilting Torque
 - Z_2 Distance Factor

The hours of life (L_h) of the unit can be determined by the following formula:

bearing life for duty cycle $\leq 40\%$

- $L_h > 10,000$ hours if $M_{2k}/M_{2A} < 1.25$ and > 1
- $L_h > 20,000$ hours if $M_{2k}/M_{2A} > 1.25$ and > 1.5
- $L_h > 30,000$ hours if $M_{2k}/M_{2A} < 1.5$

bearing life for duty cycle $\geq 40\%$

$$L_{hA} = L_h \left(\frac{40\%}{\text{Duty Cycle}} \right)$$

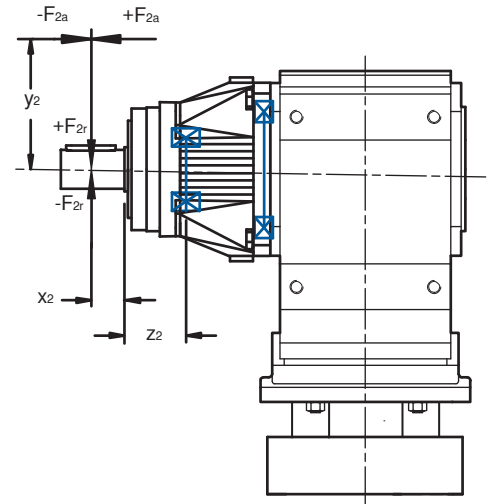

Table No. 2

R – Output Bearing Option, Normal												
Unit No.	Z_2		F_{2A}		F_{2R}		F_{2RB}		M_{2K}		M_{2KB}	
	mm	inches	N	lbs.	N	lbs.	N	lbs.	Nm	in.lbs.	Nm	in.lbs.
P5K	23	.906	2,300	518	6,500	1,463	7,000	1,575	338	2,708	364	3,221
P7K	26	1.023	2,900	653	8,000	1,800	9,000	2,025	536	4,744	603	5,337
P8K	28	1.102	4,700	1,058	13,000	2,925	18,000	4,050	897	7,938	1,242	10,992
P9K	40	1.575	6,000	1,350	18,000	4,050	27,000	6,075	1,665	14,735	2,498	22,107
D – Output Bearing Option, Axially Reinforced												
Unit No.	Z_2		F_{2A}		F_{2R}		F_{2RB}		M_{2K}		M_{2KB}	
	mm	inches	N	lbs.	N	lbs.	N	lbs.	Nm	in.lbs.	Nm	in.lbs.
P5K	29	1.142	3,500	788	7,000	1,575	8,000	1,800	406	3,593	464	4,106
P7K	31	1.220	4,500	1,013	9,000	2,025	10,000	2,250	648	5,735	720	6,372
P8K	35	1.378	7,500	1,688	15,000	3,375	18,000	4,050	1,140	10,089	1,368	12,107
P9K	51	2.008	10,000	2,250	20,000	4,500	30,000	6,750	2,070	18,320	3,105	27,479
Z – Output Bearing Option, Radially Reinforced												
Unit No.	Z_2		F_{2A}		F_{2R}		F_{2RB}		M_{2K}		M_{2KB}	
	mm	inches	N	lbs.	N	lbs.	N	lbs.	Nm	in.lbs.	Nm	in.lbs.
P5K	23	.91	1,600	360	8,000	1,800	8,000	1,800	416	3,682	416	3,682
P7K	26	1.02	2,000	450	10,000	2,250	10,000	2,250	670	5,929	670	5,929
P8K	28	1.10	3,600	810	18,000	4,050	18,000	4,050	1,242	10,992	1,242	10,992
P9K	40	1.58	5,000	1,125	27,000	6,075	35,000	7,875	2,500	22,125	3,238	28,656

During EMERGENCY OFF operation (maximum stops per gearhead = 1000) the permissible values in the table for F_{2A} , F_{2R} , and M_{2K} can be multiplied by a factor of 2.

The permissible load values given are valid with the load applied to the center of the output shaft (x_2).



"PK" Series – Right Angle ServoFit® Precision Planetary Gearhead Selection Data



Part Number	Reducer Ratio i		Input RPM			Backlash arcmins $\Delta\phi$	Input Inertia J_1 kgcm ²	Torsional Stiffness per arcmin C_2		Output Torque					
			Maximum							Nominal ¹⁾		Acceleration		Peak ²⁾	
	Nom.	Exact	n_{1DBH}	n_{1DBV}	n_{1ZB}			$M_{2N \leq 2000 \text{ RPM}}$		M_{2B}		M_{2PEAK}			
								in.lbs.	Nm	in.lbs.	Nm	in.lbs.	Nm		
P521_0030 K102VF0040 MT10	12.00	12/1	3,300	2,800	4,500	5	1.51	202	22.8	1,063	120	1,071	121	1,423	161
P521_0030 K102VF0040 MT20	12.00	12/1	3,300	2,800	4,500	5	2.11	202	22.8	1,063	120	1,772	200	2,680	303
P521_0040 K102VF0040 MT10	16.00	16/1	3,300	2,800	4,500	4.5	1.49	219	24.8	1,428	161	1,428	161	1,897	214
P521_0040 K102VF0040 MT20	16.00	16/1	3,300	2,800	4,500	4.5	2.09	219	24.8	1,860	210	2,657	300	3,573	403
P521_0050 K102VF0040 MT10	20.00	20/1	3,300	2,800	4,500	4	1.47	233	26.3	1,785	202	1,785	202	2,372	268
P521_0050 K102VF0040 MT20	20.00	20/1	3,300	2,800	4,500	4	2.07	233	26.3	1,860	210	2,657	300	4,466	504
P521_0050 K102VF0056 MT10	27.84	7600/273	3,300	2,800	4,500	4	1.31	233	26.3	1,860	210	2,485	281	3,301	373
P521_0050 K102VF0056 MT20	27.84	7600/273	3,300	2,800	4,500	4	1.91	233	26.3	1,860	210	2,657	300	5,315	600
P521_0050 K102VF0060 MT10	30.00	30/1	3,300	2,800	4,500	4	1.07	233	26.3	1,860	210	2,537	286	3,370	380
P521_0050 K102VF0060 MT20	30.00	30/1	3,300	2,800	4,500	4	1.67	233	26.3	1,860	210	2,657	300	5,315	600
P521_0050 K102VF0066 MT10	33.22	299/9	3,600	3,300	5,000	4	1.00	233	26.3	1,860	210	2,657	300	3,669	414
P521_0050 K102VF0066 MT20	33.22	299/9	3,500	3,300	5,000	4	1.60	233	26.3	1,860	210	2,657	300	5,315	600
P521_0050 K102VF0083 MT10	41.55	1911/46	3,600	3,300	5,000	4	0.89	233	26.3	1,860	210	2,657	300	4,409	498
P521_0050 K102VF0083 MT20	41.55	1911/46	3,500	3,300	5,000	4	1.49	233	26.3	1,860	210	2,657	300	5,315	600
P521_0050 K102VF0092 MT10	46.25	8740/189	3,600	3,300	5,000	4	0.94	233	26.3	1,860	210	2,657	300	5,108	577
P521_0050 K102VF0092 MT20	46.25	8740/189	3,500	3,300	5,000	4	1.54	233	26.3	1,860	210	2,657	300	5,315	600
P521_0050 K102VF0115 MT10	57.83	1330/23	3,600	3,300	5,000	4	0.85	233	26.3	1,860	210	2,657	300	5,315	600
P521_0050 K102VF0115 MT20	57.83	1330/23	3,500	3,300	5,000	4	1.45	233	26.3	1,860	210	2,657	300	5,315	600
P521_0050 K102VF0140 MT10	70.57	494/7	4,000	3,800	5,500	4	0.79	233	26.3	1,860	210	2,657	300	5,315	600
P521_0050 K102VF0140 MT20	70.57	494/7	3,500	3,500	5,000	4	1.39	233	26.3	1,860	210	2,657	300	5,315	600
P521_0050 K102VF0175 MT10	87.82	10450/119	4,000	3,800	5,500	4	0.74	233	26.3	1,860	210	2,657	300	5,315	600
P521_0050 K102VF0175 MT20	87.82	10450/119	3,500	3,500	5,000	4	1.34	233	26.3	1,860	210	2,657	300	5,315	600
P521_0050 K102VF0230 MT10	116.3	5700/49	4,000	4,000	6,000	4	0.69	233	26.3	1,860	210	2,657	300	5,315	600
P521_0050 K102VF0230 MT20	116.3	5700/49	3,500	3,500	5,000	4	1.29	233	26.3	1,860	210	2,657	300	5,315	600
P521_0050 K102VF0280 MT10	140.2	2945/21	4,000	4,000	6,000	4	0.67	233	26.3	1,860	210	2,657	300	5,315	600
P521_0050 K102VF0280 MT20	140.2	2945/21	3,500	3,500	5,000	4	1.27	233	26.3	1,860	210	2,657	300	5,315	600
P521_0050 K102VF0350 MT10	175.5	3686/21	4,000	4,000	6,000	4	0.64	233	26.3	1,860	210	2,657	300	5,315	600
P521_0050 K102VF0350 MT20	175.5	3686/21	3,500	3,500	5,000	4	1.24	233	26.3	1,860	210	2,657	300	5,315	600
P521_0050 K102VF0470 MT10	234.6	11495/49	4,000	4,000	6,000	4	0.63	233	26.3	1,860	210	2,657	300	5,315	600
P521_0050 K102VF0560 MT10	280.5	5890/21	4,000	4,000	6,000	4	0.62	233	26.3	1,860	210	2,657	300	5,315	600

¹⁾ Maximum torque for continuous input RPM - horizontal output position.
²⁾ Maximum momentary torque for emergency stops or heavy shock load.
 Admissible stops per life of reducer = 1,000 stops maximum.

Index of Symbols

i ... Exact Ratio = Exact Tooth Count
J_1 ... Reducer Inertia
C_2 ... Torsional Stiffness
n_{1DBH} ... Maximum Continuous Input RPM Horizontal Mounting - EL1, 2, 5, 6
n_{1DBV} ... Maximum Continuous Input RPM Vertical Position - EL3 and EL4
n_{1ZB} ... Maximum Cyclic Input RPM
M_{2N} ... Nominal Torque @ 2000 RPM Input
M_{2B} ... Acceleration Torque Maximum
M_{2PEAK} ... Peak Torque



"PK" Series – Right Angle ServoFit® Precision Planetary Gearhead Selection Data



PK

Part Number	Reducer Ratio i		Input RPM				Backlash arcmins $\Delta\phi$	Input Inertia J ₁ kgcm ²	Torsional Stiffness per arcmin C ₂ in.lbs. Nm		Output Torque					
			Maximum			Nominal ¹⁾ M _{2N} ≤ 2000 RPM in.lbs. Nm					Acceleration		Peak ²⁾			
	Nom.	Exact	n _{1DBH}	n _{1DBV}	n _{1ZB}		M _{2B} in.lbs. Nm	M _{2PEAK} in.lbs. Nm								
P721S_ _K102 with Motor Mounting Plate	Continued Next Page															
P721_0070 K102VF0040 MT10	28.00	28/1	3,300	2,800	4,500	4	1.49	418	47.2	2,499	282	2,499	282	3,320	375	
P721_0070 K102VF0040 MT20	28.00	28/1	3,300	2,800	4,500	4	2.09	418	47.2	3,479	393	4,706	531	6,252	706	
P721_0070 K102VF0056 MT10	38.98	1520/39	3,300	2,800	4,500	4	1.32	418	47.2	3,479	393	3,479	393	4,622	522	
P721_0070 K102VF0056 MT20	38.98	1520/39	3,300	2,800	4,500	4	1.92	418	47.2	3,885	439	5,758	650	8,703	983	
P721_0100 K102VF0040 MT10	40.00	40/1	3,300	2,800	4,500	3.5	1.46	409	46.1	2,657	300	3,571	403	4,744	536	
P721_0100 K102VF0040 MT20	40.00	40/1	3,300	2,800	4,500	3.5	2.06	409	46.1	2,657	300	4,429	500	8,858	1,000	
P721_0070 K102VF0060 MT10	42.00	42/1	3,300	2,800	4,500	4	1.08	418	47.2	3,552	401	3,552	401	4,718	533	
P721_0070 K102VF0060 MT20	42.00	42/1	3,300	2,800	4,500	4	1.68	418	47.2	3,898	440	5,758	650	8,885	1,003	
P721_0070 K102VF0066 MT10	46.51	2093/45	3,600	3,300	5,000	4	1.01	418	47.2	3,867	437	3,867	437	5,137	580	
P721_0070 K102VF0066 MT20	46.51	2093/45	3,500	3,300	5,000	4	1.61	418	47.2	3,898	440	5,758	650	9,674	1,092	
P721_0100 K102VF0056 MT10	55.68	15200/273	3,300	2,800	4,500	3.5	1.30	409	46.1	2,657	300	4,429	500	6,603	745	
P721_0100 K102VF0056 MT20	55.68	15200/273	3,300	2,800	4,500	3.5	1.90	409	46.1	2,657	300	4,429	500	8,858	1,000	
P721_0070 K102VF0083 MT10	58.16	13377/230	3,600	3,300	5,000	4	0.89	418	47.2	3,898	440	4,646	524	6,172	697	
P721_0070 K102VF0083 MT20	58.16	13377/230	3,500	3,300	5,000	4	1.49	418	47.2	3,898	440	5,758	650	11,127	1,256	
P721_0100 K102VF0060 MT10	60.00	60/1	3,300	2,800	4,500	3.5	1.07	409	46.1	2,657	300	4,429	500	6,741	761	
P721_0100 K102VF0060 MT20	60.00	60/1	3,300	2,800	4,500	3.5	1.67	409	46.1	2,657	300	4,429	500	8,858	1,000	
P721_0070 K102VF0092 MT10	64.74	1748/27	3,600	3,300	5,000	4	0.95	418	47.2	3,898	440	5,383	608	7,152	807	
P721_0070 K102VF0092 MT20	64.74	1748/27	3,500	3,300	5,000	4	1.55	418	47.2	3,898	440	5,758	650	11,127	1,256	
P721_0100 K102VF0066 MT10	66.44	598/9	3,600	3,300	5,000	3.5	1.00	409	46.1	2,657	300	4,429	500	7,339	829	
P721_0100 K102VF0066 MT20	66.44	598/9	3,500	3,300	5,000	3.5	1.60	409	46.1	2,657	300	4,429	500	8,858	1,000	
P721_0070 K102VF0100 MT10	70.98	3549/50	4,000	3,800	5,500	4	0.82	418	47.2	3,898	440	5,475	618	7,274	821	
P721_0070 K102VF0100 MT20	70.98	3549/50	3,500	3,500	5,000	4	1.42	418	47.2	3,898	440	5,758	650	11,127	1,256	
P721_0070 K102VF0115 MT10	80.96	1862/23	3,600	3,300	5,000	4	0.85	418	47.2	3,898	440	5,758	650	8,591	970	
P721_0070 K102VF0115 MT20	80.96	1862/23	3,500	3,300	5,000	4	1.45	418	47.2	3,898	440	5,758	650	11,127	1,256	
P721_0100 K102VF0083 MT10	83.09	1911/23	3,600	3,300	5,000	3.5	0.89	409	46.1	2,657	300	4,429	500	8,817	995	
P721_0100 K102VF0083 MT20	83.09	1911/23	3,500	3,300	5,000	3.5	1.49	409	46.1	2,657	300	4,429	500	8,858	1,000	
P721_0070 K102VF0125 MT10	88.33	3003/34	4,000	3,800	5,500	4	0.75	418	47.2	3,898	440	5,758	650	8,691	981	
P721_0070 K102VF0125 MT20	88.33	3003/34	3,500	3,500	5,000	4	1.35	418	47.2	3,898	440	5,758	650	11,127	1,256	
P721_0100 K102VF0092 MT10	92.49	17480/189	3,600	3,300	5,000	3.5	0.94	409	46.1	2,657	300	4,429	500	8,858	1,000	
P721_0100 K102VF0092 MT20	92.49	17480/189	3,500	3,300	5,000	3.5	1.54	409	46.1	2,657	300	4,429	500	8,858	1,000	
P721_0070 K102VF0140 MT10	98.80	494/5	4,000	3,800	5,500	4	0.79	418	47.2	3,898	440	5,758	650	10,124	1,143	
P721_0070 K102VF0140 MT20	98.80	494/5	3,500	3,500	5,000	4	1.39	418	47.2	3,898	440	5,758	650	11,127	1,256	
P721_0100 K102VF0115 MT10	115.7	2660/23	3,600	3,300	5,000	3.5	0.85	409	46.1	2,657	300	4,429	500	8,858	1,000	
P721_0100 K102VF0115 MT20	115.7	2660/23	3,500	3,300	5,000	3.5	1.45	409	46.1	2,657	300	4,429	500	8,858	1,000	

Motor Shaft

Motor Adapter	Max. Shaft Diameter
MT10	19
MT20	24
MT30	38
MT40	48

See Page 54 for Options and Part Number Configuration.



"PK" Series – Right Angle ServoFit® Precision Planetary Gearhead Selection Data



Part Number	Reducer Ratio i		Input RPM			Backlash arcmins $\Delta\phi$	Input Inertia J_1 kgcm ²	Torsional Stiffness per arcmin C_2		Output Torque					
			Maximum							Nominal ¹⁾		Acceleration		Peak ²⁾	
	Nom.	Exact	n_{1DBH}	n_{1DBV}	n_{1ZB}			$M_{2N \leq 2000 \text{ RPM}}$		M_{2B}		M_{2PEAK}			
								in.lbs.	Nm	in.lbs.	Nm	in.lbs.	Nm	in.lbs.	Nm
P721_0070 K102VF0165 MT10	117.0	117/1	4,000	4,000	6,000	4	0.70	418	47.2	3,898	440	5,758	650	10,967	1,238
P721_0070 K102VF0165 MT20	117.0	117/1	3,500	3,500	5,000	4	1.30	418	47.2	3,898	440	5,758	650	10,967	1,238
P721_0070 K102VF0175 MT10	122.9	2090/17	4,000	3,800	5,500	4	0.74	418	47.2	3,898	440	5,758	650	11,127	1,256
P721_0070 K102VF0175 MT20	122.9	2090/17	3,500	3,500	5,000	4	1.34	418	47.2	3,898	440	5,758	650	11,127	1,256
P721_0070 K102VF0200 MT10	141.1	2821/20	4,000	4,000	6,000	4	0.67	418	47.2	3,898	440	5,758	650	11,127	1,256
P721_0070 K102VF0200 MT20	141.1	2821/20	3,500	3,500	5,000	4	1.27	418	47.2	3,898	440	5,758	650	11,127	1,256
P721_0070 K102VF0230 MT10	162.9	1140/7	4,000	4,000	6,000	4	0.69	418	47.2	3,898	440	5,758	650	11,127	1,256
P721_0070 K102VF0230 MT20	162.9	1140/7	3,500	3,500	5,000	4	1.29	418	47.2	3,898	440	5,758	650	11,127	1,256
P721_0070 K102VF0250 MT10	176.5	8827/50	4,000	4,000	6,000	4	0.65	418	47.2	3,898	440	5,758	650	11,127	1,256
P721_0070 K102VF0250 MT20	176.5	8827/50	3,500	3,500	5,000	4	1.25	418	47.2	3,898	440	5,758	650	11,127	1,256
P721_0070 K102VF0280 MT10	196.3	589/3	4,000	4,000	6,000	4	0.67	418	47.2	3,898	440	5,758	650	11,127	1,256
P721_0070 K102VF0280 MT20	196.3	589/3	3,500	3,500	5,000	4	1.27	418	47.2	3,898	440	5,758	650	11,127	1,256
P721_0100 K102VF0230 MT10	232.7	11400/49	4,000	4,000	6,000	3.5	0.69	409	46.1	2,657	300	4,429	500	8,858	1,000
P721_0100 K102VF0230 MT20	232.7	11400/49	3,500	3,500	5,000	3.5	1.29	409	46.1	2,657	300	4,429	500	8,858	1,000
P721_0070 K102VF0340 MT10	235.9	4719/20	4,000	4,000	6,000	4	0.63	418	47.2	3,898	440	5,268	595	9,331	1,053
P721_0070 K102VF0350 MT10	245.7	3686/15	4,000	4,000	6,000	4	0.64	418	47.2	3,898	440	5,758	650	11,127	1,256
P721_0070 K102VF0350 MT20	245.7	3686/15	3,500	3,500	5,000	4	1.24	418	47.2	3,898	440	5,758	650	11,127	1,256
P721_0100 K102VF0280 MT10	280.5	5890/21	4,000	4,000	6,000	3.5	0.67	409	46.1	2,657	300	4,429	500	8,858	1,000
P721_0100 K102VF0280 MT20	280.5	5890/21	3,500	3,500	5,000	3.5	1.27	409	46.1	2,657	300	4,429	500	8,858	1,000
P721_0070 K102VF0400 MT10	282.1	2821/10	4,000	4,000	6,000	4	0.62	418	47.2	3,697	417	4,436	501	6,105	689
P721_0070 K102VF0470 MT10	328.4	2299/7	4,000	4,000	6,000	4	0.63	418	47.2	3,898	440	5,758	650	11,127	1,256
P721_0100 K102VF0350 MT10	351.1	7372/21	4,000	4,000	6,000	3.5	0.64	409	46.1	2,657	300	4,429	500	8,858	1,000
P721_0100 K102VF0350 MT20	351.1	7372/21	3,500	3,500	5,000	3.5	1.24	409	46.1	2,657	300	4,429	500	8,858	1,000
P721_0070 K102VF0500 MT10	352.2	35217/100	4,000	4,000	6,000	4	0.62	418	47.2	3,004	339	3,604	407	6,385	721
P721_0070 K102VF0560 MT10	392.7	1178/3	4,000	4,000	6,000	4	0.62	418	47.2	3,898	440	5,758	650	8,498	959
P721_0100 K102VF0470 MT10	469.2	22990/49	4,000	4,000	6,000	3.5	0.63	409	46.1	2,657	300	4,429	500	8,858	1,000
P721_0070 K102VF0700 MT10	490.2	2451/5	4,000	4,000	6,000	4	0.61	418	47.2	3,898	440	5,017	566	8,888	1,003
P721_0100 K102VF0560 MT10	561.0	11780/21	4,000	4,000	6,000	3.5	0.62	409	46.1	2,657	300	4,429	500	8,858	1,000

P721S_ _K102 with Motor Mounting Plate *Continued*

¹⁾ Maximum torque for continuous input RPM - horizontal output position.
²⁾ Maximum momentary torque for emergency stops or heavy shock load.
 Admissible stops per life of reducer = 1,000 stops maximum.

Index of Symbols

i ... Exact Ratio = Exact Tooth Count
J_1 ... Reducer Inertia
C_2 ... Torsional Stiffness
n_{1DBH} ... Maximum Continuous Input RPM Horizontal Mounting - EL1, 2, 5, 6
n_{1DBV} ... Maximum Continuous Input RPM Vertical Position - EL3 and EL4
n_{1ZB} ... Maximum Cyclic Input RPM
M_{2N} ... Nominal Torque @ 2000 RPM Input
M_{2B} ... Acceleration Torque Maximum
M_{2PEAK} ... Peak Torque



"PK" Series – Right Angle ServoFit® Precision Planetary Gearhead Selection Data



PK

Part Number	Reducer Ratio i		Input RPM			Backlash arcmins $\Delta\phi$	Input Inertia J ₁ kgcm ²	Torsional Stiffness per arcmin C ₂ in.lbs. Nm		Output Torque					
			Maximum							Nominal ¹⁾		Acceleration		Peak ²⁾	
	Nom.	Exact	n _{1DBH}	n _{1DBV}	n _{1ZB}	M _{2N} ≤ 2000 RPM	M _{2B}		M _{2PEAK}						
							in.lbs.	Nm	in.lbs.	Nm	in.lbs.	Nm			

P721S_ _K202 with Motor Mounting Plate *Continued Next Page*

P721_0030 K202VF0040 MT10	12.00	12/1	3,000	2,600	4,000	4.5	3.59	341	38.5	1,143	129	1,143	129	1,518	171
P721_0030 K202VF0040 MT20	12.00	12/1	3,000	2,600	4,000	4.5	4.19	341	38.5	2,480	280	4,401	497	6,711	758
P721_0030 K202VF0040 MT30	12.00	12/1	3,000	2,600	4,000	4.5	8.99	341	38.5	2,480	280	4,429	500	6,711	758
P721_0040 K202VF0040 MT10	16.00	16/1	3,000	2,600	4,000	4.5	3.29	393	44.4	1,524	172	1,524	172	2,024	229
P721_0040 K202VF0040 MT20	16.00	16/1	3,000	2,600	4,000	4.5	3.89	393	44.4	3,550	401	5,867	662	8,948	1,010
P721_0040 K202VF0040 MT30	16.00	16/1	3,000	2,600	4,000	4.5	8.69	393	44.4	3,550	401	5,997	677	8,948	1,010
P721_0050 K202VF0040 MT10	20.00	20/1	3,000	2,600	4,000	4	3.20	419	47.3	1,904	215	1,904	215	2,530	286
P721_0050 K202VF0040 MT20	20.00	20/1	3,000	2,600	4,000	4	3.80	419	47.3	3,898	440	6,201	700	11,185	1,263
P721_0050 K202VF0040 MT30	20.00	20/1	3,000	2,600	4,000	4	8.60	419	47.3	3,898	440	6,201	700	11,185	1,263
P721_0050 K202VF0052 MT20	25.89	10535/407	3,000	2,600	4,000	4	2.94	419	47.3	3,898	440	6,201	700	12,401	1,400
P721_0050 K202VF0052 MT30	25.89	10535/407	3,000	2,600	4,000	4	7.74	419	47.3	3,898	440	6,201	700	12,401	1,400
P721_0050 K202VF0060 MT10	30.00	30/1	3,000	2,600	4,000	4	2.38	419	47.3	2,808	317	2,808	317	3,730	421
P721_0050 K202VF0060 MT20	30.00	30/1	3,000	2,600	4,000	4	2.98	419	47.3	3,898	440	6,201	700	12,401	1,400
P721_0050 K202VF0060 MT30	30.00	30/1	3,000	2,600	4,000	4	7.78	419	47.3	3,898	440	6,201	700	12,401	1,400
P721_0050 K202VF0067 MT10	33.42	11395/341	3,500	3,100	4,500	4	1.76	419	47.3	2,953	333	2,953	333	3,923	443
P721_0050 K202VF0067 MT20	33.42	11395/341	3,500	3,100	4,500	4	2.36	419	47.3	3,898	440	6,201	700	12,401	1,400
P721_0050 K202VF0067 MT30	33.42	11395/341	3,500	3,100	4,000	4	7.16	419	47.3	3,898	440	6,201	700	12,401	1,400
P721_0050 K202VF0084 MT10	41.99	12470/297	3,500	3,100	4,500	4	1.41	419	47.3	3,584	405	3,584	405	4,761	538
P721_0050 K202VF0084 MT20	41.99	12470/297	3,500	3,100	4,500	4	2.01	419	47.3	3,898	440	6,201	700	12,401	1,400
P721_0050 K202VF0084 MT30	41.99	12470/297	3,500	3,100	4,000	4	6.81	419	47.3	3,898	440	6,201	700	12,401	1,400
P721_0050 K202VF0092 MT10	45.95	11395/248	3,500	3,100	4,500	4	1.56	419	47.3	3,898	440	4,060	458	5,394	609
P721_0050 K202VF0092 MT20	45.95	11395/248	3,500	3,100	4,500	4	2.16	419	47.3	3,898	440	6,201	700	12,401	1,400
P721_0050 K202VF0092 MT30	45.95	11395/248	3,500	3,100	4,000	4	6.96	419	47.3	3,898	440	6,201	700	12,401	1,400
P721_0050 K202VF0115 MT10	57.73	6235/108	3,500	3,100	4,500	4	1.29	419	47.3	3,898	440	4,928	556	6,547	739
P721_0050 K202VF0115 MT20	57.73	6235/108	3,500	3,100	4,500	4	1.89	419	47.3	3,898	440	6,201	700	12,401	1,400
P721_0050 K202VF0115 MT30	57.73	6235/108	3,500	3,100	4,000	4	6.69	419	47.3	3,898	440	6,201	700	12,401	1,400
P721_0050 K202VF0140 MT10	69.26	14405/208	3,900	3,500	5,000	4	1.12	419	47.3	3,898	440	5,704	644	7,578	856
P721_0050 K202VF0140 MT20	69.26	14405/208	3,500	3,500	5,000	4	1.72	419	47.3	3,898	440	6,201	700	12,401	1,400
P721_0050 K202VF0140 MT30	69.26	14405/208	3,500	3,500	4,000	4	6.52	419	47.3	3,898	440	6,201	700	12,401	1,400
P721_0050 K202VF0175 MT10	87.35	2795/32	3,900	3,500	5,000	4	0.97	419	47.3	3,898	440	6,201	700	9,190	1,037
P721_0050 K202VF0175 MT20	87.35	2795/32	3,500	3,500	5,000	4	1.57	419	47.3	3,898	440	6,201	700	12,401	1,400
P721_0050 K202VF0175 MT30	87.35	2795/32	3,500	3,500	4,000	4	6.37	419	47.3	3,898	440	6,201	700	12,401	1,400
P721_0050 K202VF0230 MT10	115.9	14835/128	4,000	3,900	5,500	4	0.84	419	47.3	3,898	440	6,201	700	11,532	1,302
P721_0050 K202VF0230 MT20	115.9	14835/128	3,500	3,500	5,000	4	1.44	419	47.3	3,898	440	6,201	700	12,401	1,400
P721_0050 K202VF0230 MT30	115.9	14835/128	3,500	3,500	4,000	4	6.24	419	47.3	3,898	440	6,201	700	12,401	1,400
P721_0050 K202VF0280 MT10	139.8	559/4	4,000	3,900	5,500	4	0.78	419	47.3	3,898	440	6,201	700	12,401	1,400

Motor Shaft

Motor Adapter	Max. Shaft Diameter
MT10	19
MT20	24
MT30	38
MT40	48

See Page 54 for Options and Part Number Configuration.



"PK" Series – Right Angle ServoFit® Precision Planetary Gearhead Selection Data



Part Number	Reducer Ratio i		Input RPM			Backlash arcmins $\Delta\phi$	Input Inertia J_1 kgcm ²	Torsional Stiffness per arcmin C_2		Output Torque					
			Maximum							Nominal ¹⁾		Acceleration		Peak ²⁾	
	Nom.	Exact	n_{1DBH}	n_{1DBV}	n_{1ZB}			$M_{2N \leq 2000 \text{ RPM}}$		M_{2B}		M_{2PEAK}			
								in.lbs.	Nm	in.lbs.	Nm	in.lbs.	Nm		

P721S_ _K202 with Motor Mounting Plate *Continued*

P721_0050 K202VF0280 MT20	139.8	559/4	3,500	3,500	5,000	4	1.38	419	47.3	3,898	440	6,201	700	12,401	1,400
P721_0050 K202VF0280 MT30	139.8	559/4	3,500	3,500	4,000	4	6.18	419	47.3	3,898	440	6,201	700	12,401	1,400
P721_0050 K202VF0350 MT10	172.8	9675/56	4,000	3,900	5,500	4	0.73	419	47.3	3,898	440	6,201	700	12,401	1,400
P721_0050 K202VF0350 MT20	172.8	9675/56	3,500	3,500	5,000	4	1.33	419	47.3	3,898	440	6,201	700	12,401	1,400
P721_0050 K202VF0350 MT30	172.8	9675/56	3,500	3,500	4,000	4	6.13	419	47.3	3,898	440	6,201	700	12,401	1,400
P721_0050 K202VF0460 MT10	231.1	1849/8	4,000	3,900	5,500	4	0.68	419	47.3	3,898	440	6,201	700	12,401	1,400
P721_0050 K202VF0460 MT20	231.1	1849/8	3,500	3,500	5,000	4	1.28	419	47.3	3,898	440	6,201	700	12,401	1,400
P721_0050 K202VF0560 MT10	277.7	6665/24	4,000	3,900	5,500	4	0.65	419	47.3	3,898	440	6,201	700	11,976	1,352

P821S_ _K202 with Motor Mounting Plate *Continued Next Page*

P821_0070 K202VF0040 MT10	28.00	28/1	3,000	2,600	4,000	3.5	3.37	1,168	131.9	2,666	301	2,666	301	3,542	400
P821_0070 K202VF0040 MT20	28.00	28/1	3,000	2,600	4,000	3.5	3.97	1,168	131.9	6,212	701	10,268	1,159	15,659	1,768
P821_0070 K202VF0040 MT30	28.00	28/1	3,000	2,600	4,000	3.5	8.77	1,168	131.9	6,212	701	10,495	1,185	15,659	1,768
P821_0070 K202VF0044 MT10	30.55	336/11	3,000	2,600	4,000	3.5	2.99	1,168	131.9	2,859	323	2,859	323	3,798	429
P821_0070 K202VF0044 MT20	30.55	336/11	3,000	2,600	4,000	3.5	3.59	1,168	131.9	6,395	722	10,804	1,220	16,791	1,896
P821_0070 K202VF0044 MT30	30.55	336/11	3,000	2,600	4,000	3.5	8.39	1,168	131.9	6,395	722	10,804	1,220	16,791	1,896
P821_0070 K202VF0052 MT20	36.24	14749/407	3,000	2,600	4,000	3.5	3.04	1,168	131.9	6,770	764	11,437	1,291	19,658	2,219
P821_0070 K202VF0052 MT30	36.24	14749/407	3,000	2,600	4,000	3.5	7.84	1,168	131.9	6,770	764	11,437	1,291	19,658	2,219
P821_0100 K202VF0040 MT10	40.00	40/1	3,000	2,600	4,000	3.5	3.22	1,185	133.8	3,809	430	3,809	430	5,060	571
P821_0100 K202VF0040 MT20	40.00	40/1	3,000	2,600	4,000	3.5	3.82	1,185	133.8	6,201	700	10,630	1,200	21,259	2,400
P821_0100 K202VF0040 MT30	40.00	40/1	3,000	2,600	4,000	3.5	8.62	1,185	133.8	6,201	700	10,630	1,200	21,259	2,400
P821_0070 K202VF0060 MT10	42.00	42/1	3,000	2,600	4,000	3.5	2.46	1,168	131.9	3,931	444	3,931	444	5,222	590
P821_0070 K202VF0060 MT20	42.00	42/1	3,000	2,600	4,000	3.5	3.06	1,168	131.9	7,111	803	12,013	1,356	23,086	2,606
P821_0070 K202VF0060 MT30	42.00	42/1	3,000	2,600	4,000	3.5	7.86	1,168	131.9	7,111	803	12,013	1,356	23,086	2,606
P821_0070 K202VF0067 MT10	46.78	15953/341	3,500	3,100	4,500	3.5	1.82	1,168	131.9	4,134	467	4,134	467	5,492	620
P821_0070 K202VF0067 MT20	46.78	15953/341	3,500	3,100	4,500	3.5	2.42	1,168	131.9	7,371	832	12,401	1,400	24,278	2,741
P821_0070 K202VF0067 MT30	46.78	15953/341	3,500	3,100	4,000	3.5	7.22	1,168	131.9	7,371	832	12,401	1,400	24,278	2,741
P821_0070 K202VF0071 MT20	49.83	14749/296	3,000	2,600	4,000	3.5	2.66	1,168	131.9	7,528	850	12,401	1,400	24,900	2,811
P821_0070 K202VF0071 MT30	49.83	14749/296	3,000	2,600	4,000	3.5	7.46	1,168	131.9	7,528	850	12,401	1,400	24,900	2,811
P821_0100 K202VF0052 MT20	51.77	21070/407	3,000	2,600	4,000	3.5	2.95	1,185	133.8	6,201	700	10,630	1,200	21,259	2,400
P821_0100 K202VF0052 MT30	51.77	21070/407	3,000	2,600	4,000	3.5	7.75	1,185	133.8	6,201	700	10,630	1,200	21,259	2,400
P821_0070 K202VF0084 MT10	58.78	17458/297	3,500	3,100	4,500	3.5	1.45	1,168	131.9	5,018	566	5,018	566	6,666	753
P821_0070 K202VF0084 MT20	58.78	17458/297	3,500	3,100	4,500	3.5	2.05	1,168	131.9	7,954	898	12,401	1,400	24,900	2,811
P821_0070 K202VF0084 MT30	58.78	17458/297	3,500	3,100	4,000	3.5	6.85	1,168	131.9	7,954	898	12,401	1,400	24,900	2,811
P821_0100 K202VF0060 MT10	60.00	60/1	3,000	2,600	4,000	3.5	2.39	1,185	133.8	5,615	634	5,615	634	7,460	842
P821_0100 K202VF0060 MT20	60.00	60/1	3,000	2,600	4,000	3.5	2.99	1,185	133.8	6,201	700	10,630	1,200	21,259	2,400
P821_0100 K202VF0060 MT30	60.00	60/1	3,000	2,600	4,000	3.5	7.79	1,185	133.8	6,201	700	10,630	1,200	21,259	2,400

Index of Symbols

i ... Exact Ratio = Exact Tooth Count
J ₁ ... Reducer Inertia
C ₂ ... Torsional Stiffness
n _{1DBH} ... Maximum Continuous Input RPM Horizontal Mounting - EL1, 2, 5, 6
n _{1DBV} ... Maximum Continuous Input RPM Vertical Position - EL3 and EL4
n _{1ZB} ... Maximum Cyclic Input RPM
M _{2N} ... Nominal Torque @ 2000 RPM Input
M _{2B} ... Acceleration Torque Maximum
M _{2PEAK} ... Peak Torque

¹⁾ Maximum torque for continuous input RPM - horizontal output position.

²⁾ Maximum momentary torque for emergency stops or heavy shock load.
Admissible stops per life of reducer = 1,000 stops maximum.



"PK" Series – Right Angle ServoFit® Precision Planetary Gearhead Selection Data



PK

Part Number	Reducer Ratio i		Input RPM				Backlash arcmins $\Delta\phi$	Input Inertia J ₁ kgcm ²	Torsional Stiffness per arcmin C ₂ in.lbs. Nm		Output Torque					
			Maximum			Nominal ¹⁾ M _{2N} ≤ 2000 RPM in.lbs. Nm					Acceleration		Peak ²⁾ M _{2PEAK} in.lbs. Nm			
	Nom.	Exact	n _{1DBH}	n _{1DBV}	n _{1ZB}		in.lbs.	Nm	in.lbs.	Nm	in.lbs.	Nm				
			Continuous	Cyclic												

P821S_ _K202 with Motor Mounting Plate *Continued Next Page*

P821_0070 K202VF0092 MT10	64.33	15953/248	3,500	3,100	4,500	3.5	1.59	1,168	131.9	5,684	642	5,684	642	7,552	853
P821_0070 K202VF0092 MT20	64.33	15953/248	3,500	3,100	4,500	3.5	2.19	1,168	131.9	8,197	925	12,401	1,400	24,900	2,811
P821_0070 K202VF0092 MT30	64.33	15953/248	3,500	3,100	4,000	3.5	6.99	1,168	131.9	8,197	925	12,401	1,400	24,900	2,811
P821_0100 K202VF0067 MT10	66.83	22790/341	3,500	3,100	4,500	3.5	1.77	1,185	133.8	5,905	667	5,905	667	7,846	886
P821_0100 K202VF0067 MT20	66.83	22790/341	3,500	3,100	4,500	3.5	2.37	1,185	133.8	6,201	700	10,630	1,200	21,259	2,400
P821_0100 K202VF0067 MT30	66.83	22790/341	3,500	3,100	4,000	3.5	7.17	1,185	133.8	6,201	700	10,630	1,200	21,259	2,400
P821_0070 K202VF0100 MT10	70.51	20167/286	3,900	3,500	5,000	3.5	1.23	1,168	131.9	5,808	656	5,808	656	7,716	871
P821_0070 K202VF0100 MT20	70.51	20167/286	3,500	3,500	5,000	3.5	1.83	1,168	131.9	8,452	954	12,401	1,400	24,900	2,811
P821_0070 K202VF0100 MT30	70.51	20167/286	3,500	3,500	4,000	3.5	6.63	1,168	131.9	8,452	954	12,401	1,400	24,900	2,811
P821_0070 K202VF0115 MT10	80.82	8729/108	3,500	3,100	4,500	3.5	1.31	1,168	131.9	6,899	779	6,899	779	9,166	1,035
P821_0070 K202VF0115 MT20	80.82	8729/108	3,500	3,100	4,500	3.5	1.91	1,168	131.9	8,845	999	12,401	1,400	24,900	2,811
P821_0070 K202VF0115 MT30	80.82	8729/108	3,500	3,100	4,000	3.5	6.71	1,168	131.9	8,845	999	12,401	1,400	24,900	2,811
P821_0100 K202VF0084 MT10	83.97	24940/297	3,500	3,100	4,500	3.5	1.42	1,185	133.8	6,201	700	7,168	809	9,523	1,075
P821_0100 K202VF0084 MT20	83.97	24940/297	3,500	3,100	4,500	3.5	2.02	1,185	133.8	6,201	700	10,630	1,200	21,259	2,400
P821_0100 K202VF0084 MT30	83.97	24940/297	3,500	3,100	4,000	3.5	6.82	1,185	133.8	6,201	700	10,630	1,200	21,259	2,400
P821_0070 K202VF0125 MT10	88.94	3913/44	3,900	3,500	5,000	3.5	1.04	1,168	131.9	7,043	795	7,043	795	9,357	1,056
P821_0070 K202VF0125 MT20	88.94	3913/44	3,500	3,500	5,000	3.5	1.64	1,168	131.9	8,858	1,000	12,401	1,400	24,900	2,811
P821_0070 K202VF0125 MT30	88.94	3913/44	3,500	3,500	4,000	3.5	6.44	1,168	131.9	8,858	1,000	12,401	1,400	24,900	2,811
P821_0100 K202VF0092 MT10	91.90	11395/124	3,500	3,100	4,500	3.5	1.56	1,185	133.8	6,201	700	8,121	917	10,788	1,218
P821_0100 K202VF0092 MT20	91.90	11395/124	3,500	3,100	4,500	3.5	2.16	1,185	133.8	6,201	700	10,630	1,200	21,259	2,400
P821_0100 K202VF0092 MT30	91.90	11395/124	3,500	3,100	4,000	3.5	6.96	1,185	133.8	6,201	700	10,630	1,200	21,259	2,400
P821_0070 K202VF0140 MT10	96.96	20167/208	3,900	3,500	5,000	3.5	1.13	1,168	131.9	7,986	902	7,986	902	10,609	1,198
P821_0070 K202VF0140 MT20	96.96	20167/208	3,500	3,500	5,000	3.5	1.73	1,168	131.9	8,858	1,000	12,401	1,400	24,900	2,811
P821_0070 K202VF0140 MT30	96.96	20167/208	3,500	3,500	4,000	3.5	6.53	1,168	131.9	8,858	1,000	12,401	1,400	24,900	2,811
P821_0100 K202VF0115 MT10	115.5	6235/54	3,500	3,100	4,500	3.5	1.29	1,185	133.8	6,201	700	9,856	1,113	13,094	1,478
P821_0100 K202VF0115 MT20	115.5	6235/54	3,500	3,100	4,500	3.5	1.89	1,185	133.8	6,201	700	10,630	1,200	21,259	2,400
P821_0100 K202VF0115 MT30	115.5	6235/54	3,500	3,100	4,000	3.5	6.69	1,185	133.8	6,201	700	10,630	1,200	21,259	2,400
P821_0070 K202VF0170 MT10	118.0	20769/176	4,000	3,900	5,500	3.5	0.88	1,168	131.9	8,838	998	8,838	998	11,742	1,326
P821_0070 K202VF0170 MT20	118.0	20769/176	3,500	3,500	5,000	3.5	1.48	1,168	131.9	8,858	1,000	12,401	1,400	24,900	2,811
P821_0070 K202VF0170 MT30	118.0	20769/176	3,500	3,500	4,000	3.5	6.28	1,168	131.9	8,858	1,000	12,401	1,400	24,900	2,811
P821_0070 K202VF0175 MT10	122.3	3913/32	3,900	3,500	5,000	3.5	0.98	1,168	131.9	8,858	1,000	9,684	1,093	12,866	1,452
P821_0070 K202VF0175 MT20	122.3	3913/32	3,500	3,500	5,000	3.5	1.58	1,168	131.9	8,858	1,000	12,401	1,400	24,900	2,811
P821_0070 K202VF0175 MT30	122.3	3913/32	3,500	3,500	4,000	3.5	6.38	1,168	131.9	8,858	1,000	12,401	1,400	24,900	2,811
P821_0100 K202VF0140 MT10	138.5	14405/104	3,900	3,500	5,000	3.5	1.12	1,185	133.8	6,201	700	10,630	1,200	15,156	1,711
P821_0100 K202VF0140 MT20	138.5	14405/104	3,500	3,500	5,000	3.5	1.72	1,185	133.8	6,201	700	10,630	1,200	21,259	2,400
P821_0100 K202VF0140 MT30	138.5	14405/104	3,500	3,500	4,000	3.5	6.52	1,185	133.8	6,201	700	10,630	1,200	21,259	2,400

Motor Shaft

Motor Adapter	Max. Shaft Diameter
MT10	19
MT20	24
MT30	38
MT40	48

See Page 54 for Options and Part Number Configuration.



"PK" Series – Right Angle ServoFit® Precision Planetary Gearhead Selection Data



Part Number	Reducer Ratio i		Input RPM			Backlash arcmin	Input Inertia J ₁ kgcm ²	Torsional Stiffness per arcmin C ₂		Output Torque						
			Maximum							Nominal ¹⁾		Acceleration		Peak ²⁾		
	Nom.	Exact	n _{1DBH}	n _{1DBV}	n _{1ZB}			Δφ	in.lbs.	Nm	M _{2N} ≤ 2000 RPM		M _{2B}		M _{2PEAK}	
											in.lbs.	Nm	in.lbs.	Nm	in.lbs.	Nm
P821_0070 K202VF0200 MT10	142.3	7826/55	4,000	3,900	5,500	3.5	0.81	1,168	131.9	8,858	1,000	10,214	1,153	13,569	1,532	
P821_0070 K202VF0200 MT20	142.3	7826/55	3,500	3,500	5,000	3.5	1.41	1,168	131.9	8,858	1,000	12,401	1,400	24,900	2,811	
P821_0070 K202VF0200 MT30	142.3	7826/55	3,500	3,500	4,000	3.5	6.21	1,168	131.9	8,858	1,000	12,401	1,400	24,900	2,811	
P821_0070 K202VF0230 MT10	162.3	20769/128	4,000	3,900	5,500	3.5	0.85	1,168	131.9	8,858	1,000	12,153	1,372	16,145	1,823	
P821_0070 K202VF0230 MT20	162.3	20769/128	3,500	3,500	5,000	3.5	1.45	1,168	131.9	8,858	1,000	12,401	1,400	24,900	2,811	
P821_0070 K202VF0230 MT30	162.3	20769/128	3,500	3,500	4,000	3.5	6.25	1,168	131.9	8,858	1,000	12,401	1,400	24,900	2,811	
P821_0100 K202VF0175 MT10	174.7	2795/16	3,900	3,500	5,000	3.5	0.97	1,185	133.8	6,201	700	10,630	1,200	18,379	2,075	
P821_0100 K202VF0175 MT20	174.7	2795/16	3,500	3,500	5,000	3.5	1.57	1,185	133.8	6,201	700	10,630	1,200	21,259	2,400	
P821_0100 K202VF0175 MT30	174.7	2795/16	3,500	3,500	4,000	3.5	6.37	1,185	133.8	6,201	700	10,630	1,200	21,259	2,400	
P821_0070 K202VF0250 MT10	175.9	1935/11	4,000	3,900	5,500	3.5	0.74	1,168	131.9	8,858	1,000	12,051	1,360	16,010	1,807	
P821_0070 K202VF0250 MT20	175.9	1935/11	3,500	3,500	5,000	3.5	1.34	1,168	131.9	8,858	1,000	12,401	1,400	24,900	2,811	
P821_0070 K202VF0250 MT30	175.9	1935/11	3,500	3,500	4,000	3.5	6.14	1,168	131.9	8,858	1,000	12,401	1,400	24,900	2,811	
P821_0070 K202VF0280 MT10	195.7	3913/20	4,000	3,900	5,500	3.5	0.78	1,168	131.9	8,858	1,000	12,401	1,400	18,658	2,106	
P821_0070 K202VF0280 MT20	195.7	3913/20	3,500	3,500	5,000	3.5	1.38	1,168	131.9	8,858	1,000	12,401	1,400	24,900	2,811	
P821_0070 K202VF0280 MT30	195.7	3913/20	3,500	3,500	4,000	3.5	6.18	1,168	131.9	8,858	1,000	12,401	1,400	24,900	2,811	
P821_0100 K202VF0230 MT10	231.8	14835/64	4,000	3,900	5,500	3.5	0.84	1,185	133.8	6,201	700	10,630	1,200	21,259	2,400	
P821_0100 K202VF0230 MT20	231.8	14835/64	3,500	3,500	5,000	3.5	1.44	1,185	133.8	6,201	700	10,630	1,200	21,259	2,400	
P821_0100 K202VF0230 MT30	231.8	14835/64	3,500	3,500	4,000	3.5	6.24	1,185	133.8	6,201	700	10,630	1,200	21,259	2,400	
P821_0070 K202VF0340 MT10	235.3	12943/55	4,000	3,900	5,500	3.5	0.69	1,168	131.9	8,858	1,000	11,116	1,255	19,690	2,223	
P821_0070 K202VF0340 MT20	235.3	12943/55	3,500	3,500	5,000	3.5	1.29	1,168	131.9	8,858	1,000	11,116	1,255	19,690	2,223	
P821_0070 K202VF0350 MT10	241.9	1935/8	4,000	3,900	5,500	3.5	0.73	1,168	131.9	8,858	1,000	12,401	1,400	22,014	2,485	
P821_0070 K202VF0350 MT20	241.9	1935/8	3,500	3,500	5,000	3.5	1.33	1,168	131.9	8,858	1,000	12,401	1,400	24,900	2,811	
P821_0070 K202VF0350 MT30	241.9	1935/8	3,500	3,500	4,000	3.5	6.13	1,168	131.9	8,858	1,000	12,401	1,400	24,900	2,811	
P821_0100 K202VF0280 MT10	279.5	559/2	4,000	3,900	5,500	3.5	0.78	1,185	133.8	6,201	700	10,630	1,200	21,259	2,400	
P821_0100 K202VF0280 MT20	279.5	559/2	3,500	3,500	5,000	3.5	1.38	1,185	133.8	6,201	700	10,630	1,200	21,259	2,400	
P821_0100 K202VF0280 MT30	279.5	559/2	3,500	3,500	4,000	3.5	6.18	1,185	133.8	6,201	700	10,630	1,200	21,259	2,400	
P821_0070 K202VF0400 MT10	282.8	9331/33	4,000	3,900	5,500	3.5	0.66	1,168	131.9	6,948	784	8,337	941	12,194	1,377	
P821_0070 K202VF0460 MT10	323.6	12943/40	4,000	3,900	5,500	3.5	0.68	1,168	131.9	8,858	1,000	12,401	1,400	24,900	2,811	
P821_0070 K202VF0460 MT20	323.6	12943/40	3,500	3,500	5,000	3.5	1.28	1,168	131.9	8,858	1,000	12,401	1,400	24,900	2,811	
P821_0100 K202VF0350 MT10	345.5	9675/28	4,000	3,900	5,500	3.5	0.73	1,185	133.8	6,201	700	10,630	1,200	21,259	2,400	
P821_0100 K202VF0350 MT20	345.5	9675/28	3,500	3,500	5,000	3.5	1.33	1,185	133.8	6,201	700	10,630	1,200	21,259	2,400	
P821_0100 K202VF0350 MT30	345.5	9675/28	3,500	3,500	4,000	3.5	6.13	1,185	133.8	6,201	700	10,630	1,200	21,259	2,400	
P821_0070 K202VF0500 MT10	353.4	46655/132	4,000	3,900	5,500	3.5	0.64	1,168	131.9	5,790	654	6,948	784	12,306	1,389	
P821_0070 K202VF0560 MT10	388.8	9331/24	4,000	3,900	5,500	3.5	0.66	1,168	131.9	8,858	1,000	11,464	1,294	16,766	1,893	
P821_0100 K202VF0460 MT10	462.3	1849/4	4,000	3,900	5,500	3.5	0.68	1,185	133.8	6,201	700	10,630	1,200	21,259	2,400	
P821_0100 K202VF0460 MT20	462.3	1849/4	3,500	3,500	5,000	3.5	1.28	1,185	133.8	6,201	700	10,630	1,200	21,259	2,400	
P821_0070 K202VF0690 MT10	486.0	46655/96	4,000	3,900	5,500	3.5	0.64	1,168	131.9	7,961	899	9,553	1,078	16,922	1,910	
P821_0100 K202VF0560 MT10	555.4	6665/12	4,000	3,900	5,500	3.5	0.65	1,185	133.8	6,201	700	10,630	1,200	21,259	2,400	

P821S_ _K202 with Motor Mounting Plate *Continued*

Index of Symbols

- ¹⁾ Maximum torque for continuous input RPM - horizontal output position.
- ²⁾ Maximum momentary torque for emergency stops or heavy shock load.
Admissible stops per life of reducer = 1,000 stops maximum.

i ... Exact Ratio = Exact Tooth Count
J ₁ ... Reducer Inertia
C ₂ ... Torsional Stiffness
n _{1DBH} ... Maximum Continuous Input RPM Horizontal Mounting - EL1, 2, 5, 6
n _{1DBV} ... Maximum Continuous Input RPM Vertical Position - EL3 and EL4
n _{1ZB} ... Maximum Cyclic Input RPM
M _{2N} ... Nominal Torque @ 2000 RPM Input
M _{2B} ... Acceleration Torque Maximum
M _{2PEAK} ... Peak Torque



"PK" Series – Right Angle ServoFit® Precision Planetary Gearhead Selection Data



PK

Part Number	Reducer Ratio i		Input RPM			Backlash arcmins $\Delta\phi$	Input Inertia J ₁ kgcm ²	Torsional Stiffness per arcmin C ₂		Output Torque					
			Maximum					Nominal ¹⁾		Acceleration		Peak ²⁾			
	Nom.	Exact	n _{1DBH}	n _{1DBV}	n _{1ZB}	in.lbs.	Nm	M _{2N} ≤ 2000 RPM		M _{2B}		M _{2PEAK}			
								in.lbs.	Nm	in.lbs.	Nm	in.lbs.	Nm		

P821S_ _K302 with Motor Mounting Plate

P821_0030 K302VF0040 MT20	12.00	12/1	2,700	2,300	3,800	4.5	8.88	785	88.6	4,001	452	4,401	497	6,922	781
P821_0030 K302VF0040 MT30	12.00	12/1	2,700	2,300	3,800	4.5	13.68	785	88.6	4,663	526	7,877	889	17,064	1,926
P821_0040 K302VF0040 MT20	16.00	16/1	2,700	2,300	3,800	4	7.39	1,022	115.4	5,334	602	5,867	662	9,229	1,042
P821_0040 K302VF0040 MT30	16.00	16/1	2,700	2,300	3,800	4	12.19	1,022	115.4	6,217	702	10,503	1,186	22,752	2,569
P821_0050 K302VF0040 MT20	20.00	20/1	2,700	2,300	3,800	4	6.96	1,169	131.9	6,668	753	7,334	828	11,536	1,302
P821_0050 K302VF0040 MT30	20.00	20/1	2,700	2,300	3,800	4	11.76	1,169	131.9	7,772	877	13,129	1,482	28,346	3,200
P821_0050 K302VF0054 MT20	26.88	215/8	2,700	2,300	3,800	4	4.83	1,169	131.9	8,576	968	9,856	1,113	14,865	1,678
P821_0050 K302VF0054 MT30	26.88	215/8	2,700	2,300	3,800	4	9.63	1,169	131.9	8,576	968	11,189	1,263	14,865	1,678
P821_0050 K302VF0060 MT20	30.00	30/1	2,700	2,300	3,800	4	5.09	1,169	131.9	8,858	1,000	11,002	1,242	17,156	1,937
P821_0050 K302VF0060 MT30	30.00	30/1	2,700	2,300	3,800	4	9.89	1,169	131.9	8,858	1,000	14,173	1,600	28,346	3,200
P821_0050 K302VF0074 MT20	36.96	2365/64	2,700	2,300	3,800	4	4.10	1,169	131.9	8,858	1,000	13,552	1,530	20,441	2,308
P821_0050 K302VF0074 MT30	36.96	2365/64	2,700	2,300	3,800	4	8.90	1,169	131.9	8,858	1,000	14,173	1,600	20,441	2,308
P821_0050 K302VF0093 MT20	46.34	5375/116	3,200	2,800	4,200	4	3.27	1,169	131.9	8,858	1,000	14,173	1,600	24,913	2,813
P821_0050 K302VF0093 MT30	46.34	5375/116	3,200	2,800	4,000	4	8.07	1,169	131.9	8,858	1,000	14,173	1,600	24,913	2,813
P821_0050 K302VF0115 MT20	58.05	1161/20	3,200	2,800	4,200	4	2.69	1,169	131.9	8,858	1,000	14,173	1,600	28,346	3,200
P821_0050 K302VF0115 MT30	58.05	1161/20	3,200	2,800	4,000	4	7.49	1,169	131.9	8,858	1,000	14,173	1,600	28,346	3,200
P821_0050 K302VF0140 MT20	69.68	7525/108	3,500	3,100	5,000	4	2.30	1,169	131.9	8,858	1,000	14,173	1,600	28,346	3,200
P821_0050 K302VF0140 MT30	69.68	7525/108	3,500	3,100	4,000	4	7.10	1,169	131.9	8,858	1,000	14,173	1,600	28,346	3,200
P821_0050 K302VF0175 MT10	86.47	7955/92	3,500	3,100	5,000	4	1.40	1,169	131.9	7,065	798	7,065	798	9,386	1,060
P821_0050 K302VF0175 MT20	86.47	7955/92	3,500	3,100	5,000	4	2.00	1,169	131.9	8,858	1,000	14,173	1,600	28,346	3,200
P821_0050 K302VF0175 MT30	86.47	7955/92	3,500	3,100	4,000	4	6.80	1,169	131.9	8,858	1,000	14,173	1,600	28,346	3,200
P821_0050 K302VF0230 MT10	116.5	2795/24	3,800	3,500	5,000	4	1.11	1,169	131.9	8,858	1,000	8,950	1,010	11,890	1,342
P821_0050 K302VF0230 MT20	116.5	2795/24	3,500	3,500	5,000	4	1.71	1,169	131.9	8,858	1,000	14,173	1,600	28,346	3,200
P821_0050 K302VF0230 MT30	116.5	2795/24	3,500	3,500	4,000	4	6.51	1,169	131.9	8,858	1,000	14,173	1,600	28,346	3,200
P821_0050 K302VF0280 MT10	139.4	17845/128	3,800	3,500	5,000	4	0.98	1,169	131.9	8,858	1,000	10,368	1,171	13,775	1,555
P821_0050 K302VF0280 MT20	139.4	17845/128	3,500	3,500	5,000	4	1.58	1,169	131.9	8,858	1,000	14,173	1,600	28,346	3,200
P821_0050 K302VF0280 MT30	139.4	17845/128	3,500	3,500	4,000	4	6.38	1,169	131.9	8,858	1,000	14,173	1,600	28,346	3,200
P821_0050 K302VF0350 MT10	173.7	4515/26	3,800	3,500	5,000	4	0.87	1,169	131.9	8,858	1,000	12,262	1,384	16,290	1,839
P821_0050 K302VF0350 MT20	173.7	4515/26	3,500	3,500	5,000	4	1.47	1,169	131.9	8,858	1,000	14,173	1,600	28,346	3,200
P821_0050 K302VF0350 MT30	173.7	4515/26	3,500	3,500	4,000	4	6.27	1,169	131.9	8,858	1,000	14,173	1,600	28,346	3,200
P821_0050 K302VF0460 MT10	231.1	1849/8	3,800	3,500	5,000	4	0.76	1,169	131.9	8,858	1,000	14,173	1,600	20,372	2,300
P821_0050 K302VF0460 MT20	231.1	1849/8	3,500	3,500	5,000	4	1.36	1,169	131.9	8,858	1,000	14,173	1,600	28,346	3,200
P821_0050 K302VF0460 MT30	231.1	1849/8	3,500	3,500	4,000	4	6.16	1,169	131.9	8,858	1,000	14,173	1,600	28,346	3,200
P821_0050 K302VF0560 MT10	278.5	12255/44	3,800	3,500	5,000	4	0.72	1,169	131.9	8,858	1,000	13,647	1,541	23,628	2,667
P821_0050 K302VF0560 MT20	278.5	12255/44	3,500	3,500	5,000	4	1.32	1,169	131.9	8,858	1,000	13,647	1,541	23,628	2,667

Motor Shaft

Motor Adapter	Max. Shaft Diameter
MT10	19
MT20	24
MT30	38
MT40	48

See Page 54 for Options and Part Number Configuration.



"PK" Series – Right Angle ServoFit® Precision Planetary Gearhead Selection Data



Part Number	Reducer Ratio i		Input RPM			Backlash arcmins $\Delta\phi$	Input Inertia J_1 kgcm ²	Torsional Stiffness per arcmin C_2		Output Torque					
			Maximum							Nominal ¹⁾		Acceleration		Peak ²⁾	
	Nom.	Exact	n_{1DBH}	n_{1DBV}	n_{1ZB}			$M_{2N \leq 2000 \text{ RPM}}$		M_{2B}		M_{2PEAK}			
								Continuous	Cyclic	in.lbs.	Nm	in.lbs.	Nm	in.lbs.	Nm

P921S_ _K402 with Motor Mounting Plate *Continued Next Page*

P921_0070 K402VF0040 MT20	28.00	28/1	2,600	2,200	3,500	3.5	12.34	2,399	270.9	9,335	1,054	10,268	1,159	16,336	1,844
P921_0070 K402VF0040 MT30	28.00	28/1	2,600	2,200	3,500	3.5	17.14	2,399	270.9	16,327	1,843	23,917	2,700	43,008	4,855
P921_0070 K402VF0040 MT40	28.00	28/1	2,600	2,200	3,500	3.5	21.14	2,399	270.9	16,327	1,843	23,917	2,700	43,008	4,855
P921_0070 K402VF0044 MT20	30.55	336/11	2,600	2,200	3,500	3.5	10.83	2,399	270.9	10,184	1,150	11,202	1,265	17,822	2,012
P921_0070 K402VF0044 MT30	30.55	336/11	2,600	2,200	3,500	3.5	15.63	2,399	270.9	16,808	1,897	23,917	2,700	46,592	5,260
P921_0070 K402VF0044 MT40	30.55	336/11	2,600	2,200	3,500	3.5	19.63	2,399	270.9	16,808	1,897	23,917	2,700	46,592	5,260
P921_0070 K402VF0054 MT20	37.95	12943/341	2,600	2,200	3,500	3.5	8.03	2,399	270.9	12,653	1,428	13,918	1,571	21,798	2,461
P921_0070 K402VF0054 MT30	37.95	12943/341	2,600	2,200	3,500	3.5	12.83	2,399	270.9	17,716	2,000	23,917	2,700	47,833	5,400
P921_0070 K402VF0054 MT40	37.95	12943/341	2,600	2,200	3,500	3.5	16.83	2,399	270.9	17,716	2,000	23,917	2,700	47,833	5,400
P921_0070 K402VF0060 MT20	42.00	42/1	2,600	2,200	3,500	3.5	8.78	2,399	270.9	14,002	1,581	15,402	1,739	24,503	2,766
P921_0070 K402VF0060 MT30	42.00	42/1	2,600	2,200	3,500	3.5	13.58	2,399	270.9	17,716	2,000	23,917	2,700	47,833	5,400
P921_0070 K402VF0060 MT40	42.00	42/1	2,600	2,200	3,500	3.5	17.58	2,399	270.9	17,716	2,000	23,917	2,700	47,833	5,400
P921_0070 K402VF0067 MT20	47.03	1505/32	3,000	2,600	4,000	3.5	5.95	2,399	270.9	15,680	1,770	17,248	1,947	26,015	2,937
P921_0070 K402VF0067 MT30	47.03	1505/32	3,000	2,600	4,000	3.5	10.75	2,399	270.9	17,716	2,000	23,917	2,700	47,833	5,400
P921_0070 K402VF0067 MT40	47.03	1505/32	3,000	2,600	3,500	3.5	14.75	2,399	270.9	17,716	2,000	23,917	2,700	47,833	5,400
P921_0070 K402VF0075 MT20	52.19	12943/248	2,600	2,200	3,500	3.5	6.71	2,399	270.9	17,400	1,964	19,140	2,161	29,976	3,384
P921_0070 K402VF0075 MT30	52.19	12943/248	2,600	2,200	3,500	3.5	11.51	2,399	270.9	17,716	2,000	23,917	2,700	47,833	5,400
P921_0070 K402VF0075 MT40	52.19	12943/248	2,600	2,200	3,500	3.5	15.51	2,399	270.9	17,716	2,000	23,917	2,700	47,833	5,400
P921_0070 K402VF0084 MT20	58.64	645/11	3,000	2,600	4,000	3.5	4.53	2,399	270.9	17,716	2,000	21,504	2,428	31,370	3,541
P921_0070 K402VF0084 MT30	58.64	645/11	3,000	2,600	4,000	3.5	9.33	2,399	270.9	17,716	2,000	23,917	2,700	47,833	5,400
P921_0070 K402VF0084 MT40	58.64	645/11	3,000	2,600	3,500	3.5	13.33	2,399	270.9	17,716	2,000	23,917	2,700	47,833	5,400
P921_0070 K402VF0092 MT20	64.67	16555/256	3,000	2,600	4,000	3.5	5.09	2,399	270.9	17,716	2,000	23,714	2,677	35,768	4,038
P921_0070 K402VF0092 MT30	64.67	16555/256	3,000	2,600	4,000	3.5	9.89	2,399	270.9	17,716	2,000	23,917	2,700	47,833	5,400
P921_0070 K402VF0092 MT40	64.67	16555/256	3,000	2,600	3,500	3.5	13.89	2,399	270.9	17,716	2,000	23,917	2,700	47,833	5,400
P921_0070 K402VF0100 MT20	70.69	9331/132	3,400	3,000	4,500	3.5	3.68	2,399	270.9	17,716	2,000	23,917	2,700	36,385	4,108
P921_0070 K402VF0100 MT30	70.69	9331/132	3,400	3,000	4,000	3.5	8.48	2,399	270.9	17,716	2,000	23,917	2,700	47,833	5,400
P921_0070 K402VF0100 MT40	70.69	9331/132	3,000	3,000	3,500	3.5	12.48	2,399	270.9	17,716	2,000	23,917	2,700	47,833	5,400
P921_0070 K402VF0115 MT20	80.63	645/8	3,000	2,600	4,000	3.5	3.98	2,399	270.9	17,716	2,000	23,917	2,700	43,132	4,869
P921_0070 K402VF0115 MT30	80.63	645/8	3,000	2,600	4,000	3.5	8.78	2,399	270.9	17,716	2,000	23,917	2,700	47,833	5,400
P921_0070 K402VF0115 MT40	80.63	645/8	3,000	2,600	3,500	3.5	12.78	2,399	270.9	17,716	2,000	23,917	2,700	47,833	5,400
P921_0070 K402VF0125 MT20	88.61	2924/33	3,400	3,000	4,500	3.5	2.92	2,399	270.9	17,716	2,000	23,917	2,700	44,111	4,980
P921_0070 K402VF0125 MT30	88.61	2924/33	3,400	3,000	4,000	3.5	7.72	2,399	270.9	17,716	2,000	23,917	2,700	47,833	5,400
P921_0070 K402VF0125 MT40	88.61	2924/33	3,000	3,000	3,500	3.5	11.72	2,399	270.9	17,716	2,000	23,917	2,700	47,833	5,400
P921_0070 K402VF0140 MT20	97.20	9331/96	3,400	3,000	4,500	3.5	3.29	2,399	270.9	17,716	2,000	23,917	2,700	47,833	5,400
P921_0070 K402VF0140 MT30	97.20	9331/96	3,400	3,000	4,000	3.5	8.09	2,399	270.9	17,716	2,000	23,917	2,700	47,833	5,400
P921_0070 K402VF0140 MT40	97.20	9331/96	3,000	3,000	3,500	3.5	12.09	2,399	270.9	17,716	2,000	23,917	2,700	47,833	5,400

¹⁾ Maximum torque for continuous input RPM - horizontal output position.
²⁾ Maximum momentary torque for emergency stops or heavy shock load.
 Admissible stops per life of reducer = 1,000 stops maximum.

Index of Symbols

i ... Exact Ratio = Exact Tooth Count
J ₁ ... Reducer Inertia
C ₂ ... Torsional Stiffness
n _{1DBH} ... Maximum Continuous Input RPM Horizontal Mounting - EL1, 2, 5, 6
n _{1DBV} ... Maximum Continuous Input RPM Vertical Position - EL3 and EL4
n _{1ZB} ... Maximum Cyclic Input RPM
M _{2N} ... Nominal Torque @ 2000 RPM Input
M _{2B} ... Acceleration Torque Maximum
M _{2PEAK} ... Peak Torque



"PK" Series – Right Angle ServoFit® Precision Planetary Gearhead Selection Data



PK

Part Number	Reducer Ratio i		Input RPM			Backlash arcmins $\Delta\phi$	Input Inertia J ₁ kgcm ²	Torsional Stiffness per arcmin C ₂ in.lbs. Nm		Output Torque					
			Maximum							Nominal ¹⁾		Acceleration		Peak ²⁾	
	Nom.	Exact	n _{1DBH}	n _{1DBV}	n _{1ZB}	Cyclic	M _{2N} ≤ 2000 RPM	M _{2B}		M _{2PEAK}					
								in.lbs.	Nm	in.lbs.	Nm	in.lbs.	Nm		
P921S_ _K402 with Motor Mounting Plate <i>Continued</i>															
P921_0070 K402VF0170 MT20	118.6	3913/33	3,500	3,300	5,000	3.5	2.25	2,399	270.9	17,716	2,000	23,917	2,700	47,833	5,400
P921_0070 K402VF0170 MT30	118.6	3913/33	3,500	3,300	4,000	3.5	7.05	2,399	270.9	17,716	2,000	23,917	2,700	47,833	5,400
P921_0070 K402VF0170 MT40	118.6	3913/33	3,000	3,000	3,500	3.5	11.05	2,399	270.9	17,716	2,000	23,917	2,700	47,833	5,400
P921_0070 K402VF0175 MT20	121.8	731/6	3,400	3,000	4,500	3.5	2.68	2,399	270.9	17,716	2,000	23,917	2,700	47,833	5,400
P921_0070 K402VF0175 MT30	121.8	731/6	3,400	3,000	4,000	3.5	7.48	2,399	270.9	17,716	2,000	23,917	2,700	47,833	5,400
P921_0070 K402VF0175 MT40	121.8	731/6	3,000	3,000	3,500	3.5	11.48	2,399	270.9	17,716	2,000	23,917	2,700	47,833	5,400
P921_0070 K402VF0200 MT20	141.4	9331/66	3,500	3,300	5,000	3.5	1.98	2,399	270.9	17,716	2,000	23,917	2,700	47,833	5,400
P921_0070 K402VF0200 MT30	141.4	9331/66	3,500	3,300	4,000	3.5	6.78	2,399	270.9	17,716	2,000	23,917	2,700	47,833	5,400
P921_0070 K402VF0200 MT40	141.4	9331/66	3,000	3,000	3,500	3.5	10.78	2,399	270.9	17,716	2,000	23,917	2,700	47,833	5,400
P921_0070 K402VF0230 MT20	163.0	3913/24	3,500	3,300	5,000	3.5	2.12	2,399	270.9	17,716	2,000	23,917	2,700	47,833	5,400
P921_0070 K402VF0230 MT30	163.0	3913/24	3,500	3,300	4,000	3.5	6.92	2,399	270.9	17,716	2,000	23,917	2,700	47,833	5,400
P921_0070 K402VF0230 MT40	163.0	3913/24	3,000	3,000	3,500	3.5	10.92	2,399	270.9	17,716	2,000	23,917	2,700	47,833	5,400
P921_0070 K402VF0250 MT20	177.0	29197/165	3,500	3,300	5,000	3.5	1.74	2,399	270.9	17,716	2,000	23,917	2,700	47,833	5,400
P921_0070 K402VF0250 MT30	177.0	29197/165	3,500	3,300	4,000	3.5	6.54	2,399	270.9	17,716	2,000	23,917	2,700	47,833	5,400
P921_0070 K402VF0250 MT40	177.0	29197/165	3,000	3,000	3,500	3.5	10.54	2,399	270.9	17,716	2,000	23,917	2,700	47,833	5,400
P921_0070 K402VF0280 MT20	194.4	9331/48	3,500	3,300	5,000	3.5	1.89	2,399	270.9	17,716	2,000	23,917	2,700	47,833	5,400
P921_0070 K402VF0280 MT30	194.4	9331/48	3,500	3,300	4,000	3.5	6.69	2,399	270.9	17,716	2,000	23,917	2,700	47,833	5,400
P921_0070 K402VF0280 MT40	194.4	9331/48	3,000	3,000	3,500	3.5	10.69	2,399	270.9	17,716	2,000	23,917	2,700	47,833	5,400
P921_0070 K402VF0340 MT20	235.7	33712/143	3,500	3,300	5,000	3.5	1.53	2,399	270.9	17,716	2,000	23,917	2,700	40,558	4,579
P921_0070 K402VF0340 MT30	235.7	33712/143	3,500	3,300	4,000	3.5	6.33	2,399	270.9	17,716	2,000	23,917	2,700	40,558	4,579
P921_0070 K402VF0350 MT20	243.3	29197/120	3,500	3,300	5,000	3.5	1.68	2,399	270.9	17,716	2,000	23,917	2,700	47,833	5,400
P921_0070 K402VF0350 MT30	243.3	29197/120	3,500	3,300	4,000	3.5	6.48	2,399	270.9	17,716	2,000	23,917	2,700	47,833	5,400
P921_0070 K402VF0350 MT40	243.3	29197/120	3,000	3,000	3,500	3.5	10.48	2,399	270.9	17,716	2,000	23,917	2,700	47,833	5,400
P921_0070 K402VF0410 MT20	283.6	34314/121	3,500	3,300	5,000	3.5	1.44	2,399	270.9	17,716	2,000	22,232	2,510	39,381	4,446
P921_0070 K402VF0410 MT30	283.6	34314/121	3,500	3,300	4,000	3.5	6.24	2,399	270.9	17,716	2,000	22,232	2,510	39,381	4,446
P921_0070 K402VF0460 MT20	324.2	4214/13	3,500	3,300	5,000	3.5	1.49	2,399	270.9	17,716	2,000	23,917	2,700	47,833	5,400
P921_0070 K402VF0460 MT30	324.2	4214/13	3,500	3,300	4,000	3.5	6.29	2,399	270.9	17,716	2,000	23,917	2,700	47,833	5,400
P921_0070 K402VF0500 MT20	353.0	38829/110	3,500	3,300	5,000	3.5	1.36	2,399	270.9	16,211	1,830	19,453	2,196	29,327	3,311
P921_0070 K402VF0560 MT20	389.9	17157/44	3,500	3,300	5,000	3.5	1.41	2,399	270.9	17,716	2,000	23,917	2,700	47,833	5,400
P921_0070 K402VF0560 MT30	389.9	17157/44	3,500	3,300	4,000	3.5	6.21	2,399	270.9	17,716	2,000	23,917	2,700	47,833	5,400
P921_0070 K402VF0690 MT20	485.4	38829/80	3,500	3,300	5,000	3.5	1.34	2,399	270.9	17,716	2,000	23,917	2,700	40,325	4,552

Motor Shaft

Motor Adapter	Max. Shaft Diameter
MT10	19
MT20	24
MT30	38
MT40	48

See Page 54 for Options and Part Number Configuration.



"PK" Series – Right Angle ServoFit® Precision Planetary Gearhead Dimensional Data

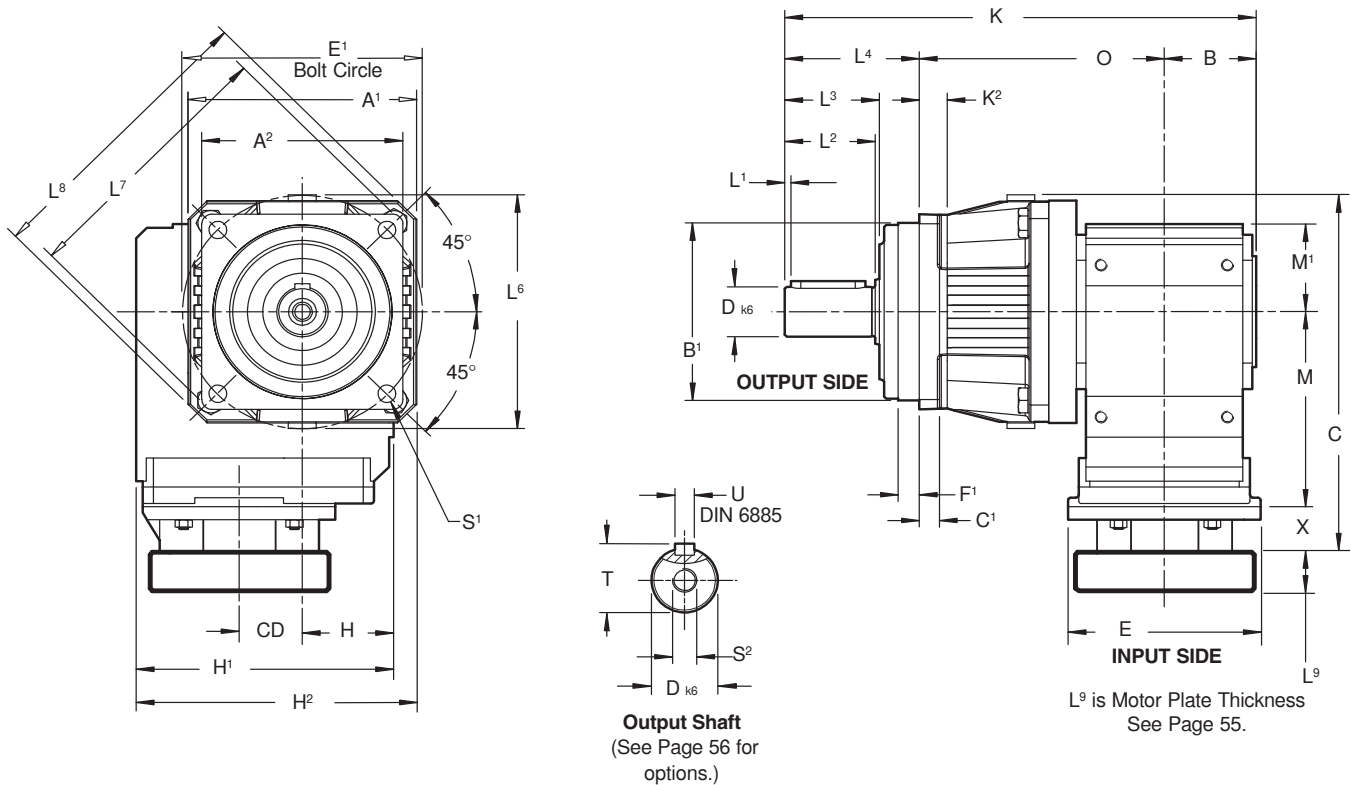

Table No. 1 "PK" Series – ServoFit Precision Planetary Gearhead Dimensions (mm)

Unit	A ¹	A ²	B	B ¹	h ₆	C ¹	D _{k6}	E ¹	F ¹	H	H ¹	H ²	K	K ²	
P521S_K102	115	101	56	90	+0.000/-0.022	10	32	+0.018/+0.002	120	15	60	160	160.5	283	14
P721S_K102	145	145	56	130	+0.000/-0.025	15	40	+0.018/+0.002	165	3.5	60	160	172.5	318	—
P721S_K202	145	145	70	130	+0.000/-0.025	15	40	+0.018/+0.002	165	3.5	65	190	207.5	346	—
P821S_K202	190	190	70	160	+0.000/-0.025	15	55	+0.021/+0.002	215	10	65	190	230	384.5	—
P821S_K302	190	190	76	160	+0.000/-0.025	15	55	+0.021/+0.002	215	10	75	213	233	398	—
P921S_K402	225	212	90	180	+0.000/-0.025	17	75	+0.021/+0.002	250	10	90	240	262.5	490.5	22

Table No. 2 "PK" Series – ServoFit Precision Planetary Gearhead Dimensions (mm)

Unit	L ¹	L ²	L ³	L ⁴	L ⁶	L ⁷	L ⁸	M ¹	O	S ¹	S ²	T	U
P521S_K102	3	58	60	88	121	139	149	60	139	9	M12x28	35	A10x8x50
P721S_K102	4	82	85	112	145	—	190	60	150	11	M16x36	43	A12x8x70
P721S_K202	4	82	85	112	145	—	190	65	164	11	M16x36	43	A12x8x70
P821S_K202	6	82	85	112	190	—	250	65	202.5	13.5	M20x42	59	A16x10x70
P821S_K302	6	82	85	112	190	—	250	75	210	13.5	M20x42	59	A16x10x70
P921S_K402	6	105	109	143	225	285	300	90	257.5	17.5	M20x42	80	A20x12x90



"PK" Series – Right Angle ServoFit® Precision Planetary Gearhead Dimensional Data



PK

Table No. 3
"MT" Motor Plate Dimensions (mm)

Motor Adapter	Motor Shaft D ⁶ Max. ¹⁾	Thickness ²⁾ L ⁹ Min.	E	X	Wt. lbs.
MT10	19	21	140	40	5
MT20	24	24	160	50	8
MT30	38	25	200	60	12
MT40	48	33	250	89	18

- ¹⁾ If an adapter bushing is required it will be supplied as a component of the motor mounting plate.
²⁾ Motor plate maximum thickness (L⁹) will vary with motor shaft length but will not be less than shown.

Table No. 4 **"PK" Series – ServoFit Precision Planetary Gearhead (mm)**

Base Module	MT10			MT20			MT30			MT40			Wt. lbs.
	CD	C	M	CD	C	M	CD	C	M	CD	C	M	
P5_K102	36	224.5	124	36	238.5	128	—	—	—	—	—	—	31
P7_K102	36	236.5	124	36	250.5	128	—	—	—	—	—	—	31
P7_K202	46	255.5	143	46	269.5	147	46	281.5	149	—	—	—	40
P8_K202	46	278	143	46	292	147	46	307	149	—	—	—	40
P8_K302	52.5	298	163	52.5	312	167	52.5	324	169	—	—	—	67
P9_K402	—	—	—	60	349.5	187	60	361.5	189	60	393.5	192	93

Part No. Example

P521SPR0050K102VF0060MT20

Specify: Mounting Position
 Side 3 or 4 for P
 Paint, if not *Black*
 Motor Information

See Page 54 for Options and Part Number Configuration.

"PH" Series ServoFit® Precision Planetary Gearhead Performance Specifications



PH

Size			PH321 PH322	PH421 PH422	PH521 PH522	PH721 PH722	PH821 PH822	PH932 PHV933	PH1032 PHV1033
+Torque Max.	Nm		65	130	320	700	2,000	5,000	7,500
Output Torque M_{2N} Nominal ¹⁾	in.lbs. Nm		398 45	796 90	1,947 220	3,894 440	11,062 1,250	26,574 3,000	44,290 5,000
Input Speed n_{1MAX} Maximum	Continuous Cyclic		3,800 4,500 6,000 8,000	3,500 4,500 6,000 8,000	3,300 4,000 6,000 7,000	3,000 3,700 5,000 6,500	2,500 3,300 4,000 6,000	2,800 2,500 4,500	2,300 2,500 4,500
ServoCool Input RPM Max.	Continuous Cyclic		— —	4,500 — 6,000 —	4,500 5,000 6,000 7,000	4,000 4,700 5,000 6,500	3,700 4,300 4,500 6,000	4,000 3,200 4,500	4,000 3,000 4,500
Torsional Backlash ²⁾	Δφ	arcmin	≤3	≤3	≤3	≤3	≤3	≤3	≤3
Torsional Stiffness	C ₂	in.lbs./arcmin Nm/arcmin	≤106 ≤12	≤292 ≤33	≤708 ≤80	≤1,371 ≤155	≤3,752 ≤424	≤10,980 ≤1,240	≤15,752 ≤1,778
Axial Load Maximum ³⁾	F _{2AMAX}	lbs. N	371 1,650	484 2,150	934 4,150	1,384 6,150	2,260 10,050	7,425 33,000	11,250 50,000
Tilting Moment Maximum ³⁾	M _{2K}	in.lbs. Nm	885 100	2,301 260	3,894 440	13,275 1,500	30,975 3,500	66,375 7,500	77,880 8,800
Tilting Stiffness	C _{2K}	in.lbs./arcmin Nm/arcmin	— —	1,416 160	2,655 300	4,425 500	13,718 1,550	66,375 7,500	84,075 9,500
Efficiency (at Nominal Torque)	h	%	96% 94%	96% 94%	96% 94%	96% 94%	96% 94%	96% 94%	94% 92%
Weight	m	pounds kg	4 1.8	9 10 3.9 4.6	15 18 6.6 8.1	27 32 12.3 14.6	76 88 34.6 39.8	166 147 75.2 66.6	200 198 90.6 90
Noise Level ⁴⁾	L _{PA}	dB(A)	≤61	≤62	≤63	≤64	≤65	≤65	≤65
Balance Quality	Q 2.5 (Quality Class-2.5 millimeters per second)								
Lubrication	Synthetic Oil (ISO VG 150)								
Degree of Protection	IP65								
Mounting Position	Unrestricted								
Ambient Temperature	0° C to +40°C (104° F) [Unit temperature ≤ 90° C Max.]								
Finish	Black (RAL 9005)								
Lifetime ⁵⁾	L _h	hours	L _h > 10,000 hours if M _{2K} /M _{2A} < 1.25 and > 1.00 L _h > 20,000 hours if M _{2K} /M _{2A} > 1.25 and < 1.50 L _h > 30,000 hours if M _{2K} /M _{2A} > 1.5						
Warranty	5 Year Limited (2 Years on normal wear items: bearings, seals, etc.)								

¹⁾ Ratings based on input speed (n₁) of 2000 RPM.

For torque at higher input speeds (M_{2NX}) solve the formula, where n₁ = Actual Input Speed.
$$M_{2NX} = \frac{M_{2N}}{\sqrt[3]{\frac{n_1}{2000}}}$$

²⁾ Tested at 1.5% of nominal torque and recorded on the output side of the gearhead.

³⁾ Rating based on output speed (n₂) of 100 RPM. For values at other speeds see Page 73.

⁴⁾ Measurement at one (1) meter distance with input speed (n₁) of 3000 RPM.

⁵⁾ M_{2A} equals actual tilting moment of the application. See Page 73 for calculation details.

WARNING: In order to insure that the specified torque ratings are attained, it is essential to use a grade 12.9 fastener on all output connections.

Refer to Page 302 for ServoFit Precision Planetary Gearhead Selection Procedure.



"PH" Series ServoFit® Precision Planetary Gearhead Features

The "PH" Series ServoFit Precision Planetary Gearheads are designed for high demands of torsional stiffness and tilting rigidity. The "PH" series is well suited where a smooth, precise, reliable drive is needed. All units are lubricated for life with synthetic oil and sealed to IP65 standards to prevent lubricant contamination for long life.

Some features are:

- Readily Attaches to Any Servo Motor
- ISO Output Flange for Coupling Free Mounting
- Superior Torsional Stiffness
- Advanced Helicamber Gear Technology
- 90-96% Efficiency
- 5 Year Limited Warranty (2 Year on bearings, seals, etc.)
- Excellent Axial Load Capacity
- Wide Selection of IEC, NEMA, or Customized* Motor Plates



P
H

* Maximum 10 working day for custom motor plates.

The output flange dimensions are ISO 9409 and allow easy mounting to rotary or indexing tables, pinions, timing belt pulleys, transmission shafting, etc., without using a coupling.

Single piece steel housing provides greater concentricity and more precise alignment

FKM seals for the smallest possible diameter—reducing friction and heat buildup, increasing efficiency, and allowing continuous duty without additional cooling.

Ring gear machined integral to the housing — not welded or pressed in

Blind pilot hole

Oversized tapered roller bearings and shafts for high radial load capacity and superior torsional stiffness

Gears are case hardened to 61 Rockwell "C" and ground for maximum efficiency

HeliCamber® gear technology provides minimum wear, low backlash, and low noise

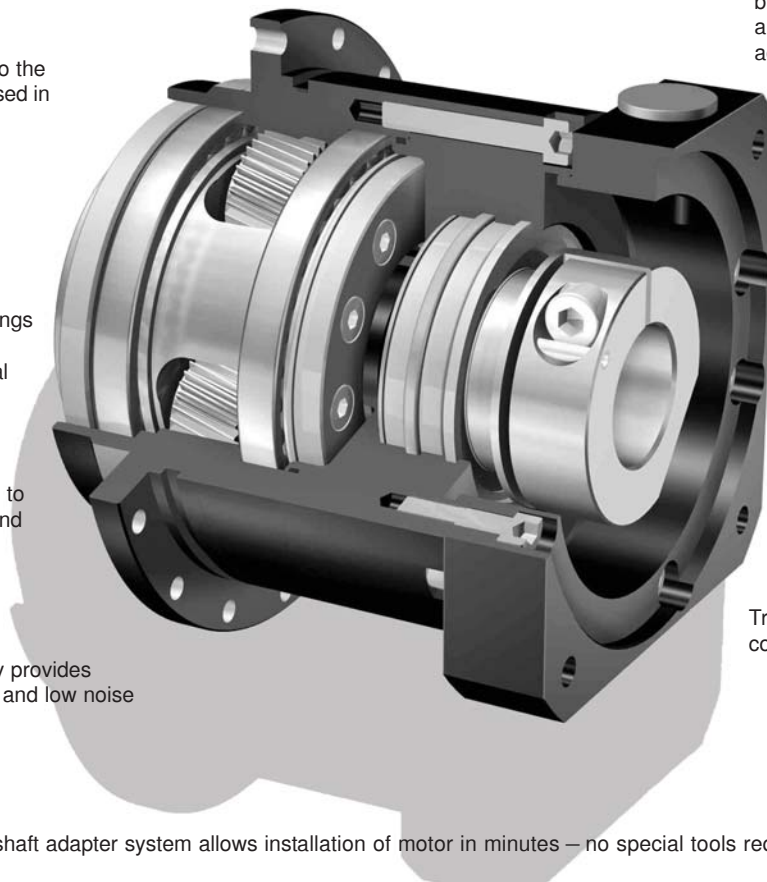

Adapter bushings fit all motor shafts — no key required

Triple-split steel collet for greater concentricity and low inertia

The motor shaft adapter system allows installation of motor in minutes — no special tools required.

The patented motor coupling is designed to allow thermal expansion of the motor shaft—ensuring long motor life by preventing thrust load on the motor bearings.

“PH” Series ServoFit® Precision Planetary Gearhead



Part No. Explanation

PH 8 2 1 F 0050 MT L

Series Size Generation No. of Gear Stages Housing Ratio Option Input Option Input Option

- Series **PH** Planetary Gearhead
 (V) 3 Stage for 9 or 10 ONLY
- Size **8** 3, 4, 5, 7, **8**, 9, 10
- Generation **2** First generation 1, second generation **2**, etc.
- No. of Gear Stages **1** 1, 2, 3 (determined by the ratio)
- Housing Style **F** Output Flange
- Ratio **0050** Approximate: 0050 = 5.00:1 (range of 4:1 up to 100:1)
- Motor Adapter **MT** TriAdapt® Motor Adapter Also, available with **AW**, Input Shaft.



Option **L** Large Input Option



C—ServoCool (available in sizes PH4 thru PH10)



Available with rack and pinion as **ZTRS**.

Contact STOBER Drives.



If a “PH” gearhead is to be mounted from the “B²” side, SPECIFY WHEN ORDERING. For proper mounting the paint must be eliminated and the tolerance held on that surface. Side “B²” mounting is not possible with the Large Input.

Motor Mounting Specifications

STOBER ServoFit Gearheads will fit the motor of your choice by assembling the correct motor mounting plate between the motor and the gearhead. **When ordering a gearhead, specify the motor manufacturer and part number, provide the motor drawing with dimensions, or specify the motor mounting dimensions.** The motor plate thickness (L⁹) dimension will be determined by the motor shaft length. The minimum motor plate thickness is shown below. For a precise dimension on a specific motor, contact STOBER Technical Support.

The following dimensions are required to provide the correct motor mounting plate:

1. D⁶ Motor Shaft Diameter (If an adapter bushing is required it will be supplied with the motor plate.)
2. D⁷ Pilot Diameter
3. D⁸ Bolt Circle Diameter
4. D⁹ Bolt Diameter
5. L¹¹ Motor Shaft Length
6. L¹² Pilot Length
7. L¹⁴ Square Flange (Optional — Motor plate will typically be made to match.)

Table No. 1

Motor Plate Dims.	Planetary Size					
	PH322	PH321 PH322L PH422	PH321L PH421 PH422L PH522	PH421L PH521 PH522L PH722 PH932	PH521L PH721 PH722L PH822 PHV933 PHV1033	PH821 PH932 PH1032
D ⁶ Max.	14	19	24	32	38	48
L ⁹ Min.	15	18	21	24	25	33

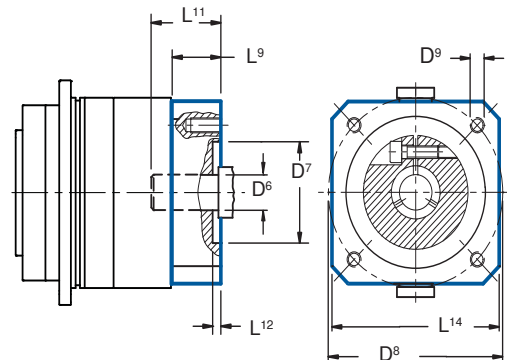



"PH" Series ServoFit® Precision Planetary Gearhead Shaft Loads

All formulas shown are based on METRIC values.

Upper case letters are permissible values. Lower case letters are for existing values.

The permissible load and tilting moment values are based on an output speed of 100 RPM. For higher speeds the following applies, where n_2 is the desired speed:

$$F_{2AX} = \frac{F_{2A}}{\sqrt[3]{\frac{n_2}{100}}} \quad M_{2KX} = \frac{M_{2K}}{\sqrt[3]{\frac{n_2}{100}}}$$

The application input tilting moment should be determined by the following formula:

$$M_{2A} = \frac{F_{2a} \cdot y_2 + F_{2rb} \cdot (X_2 + Z_2)}{1000} \leq M_{2KB}$$

$$M_{2Ka} = \sqrt[3]{\frac{\Omega_{2b1} \cdot t_{b1} \cdot M_{2kb1}^3 + \dots + \Omega_{2bn} \cdot t_{bn} \cdot M_{2kbn}^3}{\Omega_{2b1} \cdot t_{b1} + \dots + \Omega_{2bn} \cdot t_{bn}}} \leq M_{2K}$$

$$F_{2r} = \sqrt[3]{\frac{\Omega_{2b1} \cdot t_{b1} \cdot F_{2rb1}^3 + \dots + \Omega_{2bn} \cdot t_{bn} \cdot F_{2rbn}^3}{\Omega_{2b1} \cdot t_{b1} + \dots + \Omega_{2bn} \cdot t_{bn}}} \leq F_{2R}$$

- where:
- F_{2a} Axial Load at Output Shaft
 - F_{2A} Permissible Axial Load
 - F_{2r} Radial Load at Output Shaft
 - F_{2R} Permissible Radial Load
 - F_{2RB} Acceleration Permissible Radial Load
 - M_{2K} Rated Tilting Torque
 - M_{2k} Equivalent Tilting Load
 - M_{2KB} Acceleration Tilting Torque
 - Z_2 Distance Factor

The hours of life (L_h) of the unit can be determined by the following formula:

bearing life for duty cycle $\leq 40\%$
 $L_h > 10,000$ hours if $M_{2k}/M_{2A} < 1.25$ and > 1
 $L_h > 20,000$ hours if $M_{2k}/M_{2A} > 1.25$ and > 1.5
 $L_h > 30,000$ hours if $M_{2k}/M_{2A} < 1.5$

bearing life for duty cycle $\geq 40\%$
 $L_{hA} = L_h \left(\frac{40\%}{\text{Duty Cycle}} \right)$

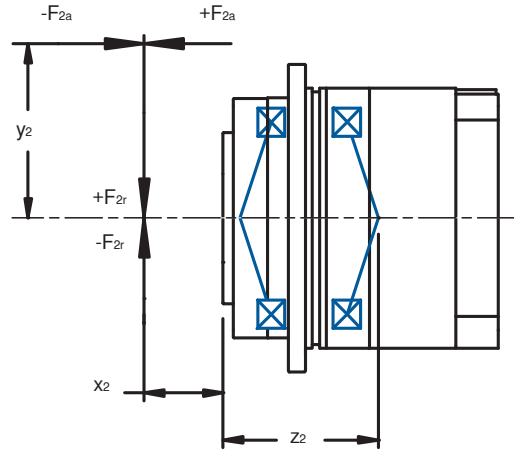

Table No. 2 "PH" Series – Permissible Output Load and Tilting Moments

Unit No.	Z_2		$F_{2A\text{MAX}}$		F_{2R}		F_{2RB}		M_{2K}		M_{2KB}		C_{2K}	
	mm	inches	N	lbs.	N	lbs.	N	lbs.	Nm	in.lbs.	Nm	in.lbs.	Nm/arcmin	In.lbs/arcmin
PH3	62	2.44	1,650	371	1,613	363	1,613	363	100	885	100	885	53	469
PH4	84	3.31	2,150	484	3,095	696	3,571	803	260	2,124	300	2,655	160	1,416
PH5	97	3.82	4,150	934	4,536	1,021	4,897	1,102	440	3,717	475	4,204	380	3,363
PH7	88	3.46	6,150	1,384	17,045	3,835	17,045	3,835	1,500	13,275	1,500	13,275	500	4,425
PH8	126	4.96	10,050	2,261	27,778	6,250	27,778	6,250	3,500	30,975	3,500	30,975	1,550	13,718
PH9, PHV9	155	6.10	33,000	7,425	48,387	10,887	70,968	15,938	7,500	66,375	11,000	97,350	7,500	66,375
PH10, PHV10	171	6.73	50,000	11,250	51,462	11,579	73,099	16,447	8,800	77,880	12,500	110,625	9,500	84,075

During EMERGENCY OFF operation (maximum stops per gearhead = 1000) the permissible values in the table for F_{2A} , F_{2R} , and M_{2K} can be multiplied by a factor of 2.

Permissible Motor Tilting Torque

The permissible tilting torque of the motor attached to the gear unit is a result of the static and dynamic load "F" from the motor weight, mass acceleration, and vibration multiplied by the distance from the center of gravity "Is" of the motor.

$$M_{1k} = F \times I_s \leq M_{1K}$$

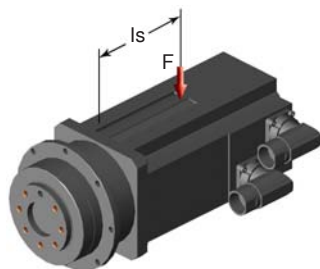

Table No. 3 M_{1K}

Unit Type with MT	Nm	inlbs.
PH422	20	177
PH421, PH522	40	354
PH521, PH722	80	708
PH721, PH822, PHV933	200	1,770
PH821, PH932, PH1032, PHV1033	400	3,540



"PH" Series ServoFit® Precision Planetary Gearhead Selection Data



PH

Part Number (Gearhead + Input)	Exact Ratio i	Maximum Input Speed		Maximum Motor Shaft øD ⁶ mm	Input ¹⁾ Inertia J ₁ kgcm ²	Torsional Stiffness per arcmin C ₂		Output Torque					
		Continuous RPM (n ₁)	Cyclic RPM (n ₁)			in.lbs.	Nm	Nominal ²⁾ M _{2N}		Acceleration M _{2B}		Peak ³⁾ M _{2PEAK}	
								in.lbs.	Nm	in.lbs.	Nm	in.lbs.	Nm

PH321 with Motor Mounting Plate

PH321F0050MT	5.000	3,000	6,000	19	0.64	115	13.0	399	45	576	65	1,152	130
PH321F0050MTL	5.000	3,000	6,000	24	1.32	115	13.0	399	45	576	65	1,152	130
PH321F0070MT	7.000	3,500	6,000	19	0.59	102	11.5	399	45	531	60	1,152	130
PH321F0070MTL	7.000	3,500	6,000	24	1.26	102	11.5	399	45	531	60	1,152	130
PH321F0100MT	10.00	3,800	6,000	19	0.57	79.7	9.0	266	30	443	50	886	100
PH321F0100MTL	10.00	3,800	6,000	24	1.25	79.7	9.0	266	30	443	50	886	100

PH322 with Motor Mounting Plate

PH322F0200MT	20.00	4,500	8,000	14	0.14	89.7	10.1	399	45	576	65	1,152	130
PH322F0200MTL	20.00	4,500	8,000	19	0.61	90.4	10.2	399	45	576	65	1,152	130
PH322F0250MT	25.00	4,500	8,000	14	0.12	89.9	10.2	399	45	576	65	1,152	130
PH322F0250MTL	25.00	4,500	8,000	19	0.59	90.4	10.2	399	45	576	65	1,152	130
PH322F0280MT	28.00	4,500	8,000	14	0.14	90.3	10.2	399	45	531	60	1,152	130
PH322F0280MTL	28.00	4,500	8,000	19	0.61	90.7	10.2	399	45	531	60	1,152	130
PH322F0350MT	35.00	4,500	8,000	14	0.11	89.0	10.0	399	45	576	65	1,152	130
PH322F0350MTL	35.00	4,500	8,000	19	0.57	89.3	10.1	399	45	576	65	1,152	130
PH322F0400MT	40.00	4,500	8,000	14	0.14	76.0	8.6	266	30	443	50	886	100
PH322F0400MTL	40.00	4,500	8,000	19	0.61	76.1	8.6	266	30	443	50	886	100
PH322F0500MT	50.00	4,500	8,000	14	0.10	86.7	9.8	399	45	576	65	1,152	130
PH322F0500MTL	50.00	4,500	8,000	19	0.56	86.9	9.8	399	45	576	65	1,152	130
PH322F0700MT	70.00	4,500	8,000	14	0.10	88.7	10.0	399	45	531	60	1,152	130
PH322F0700MTL	70.00	4,500	8,000	19	0.56	88.8	10.0	399	45	531	60	1,152	130
PH322F1000MT	100.0	4,500	8,000	14	0.10	75.4	8.5	266	30	443	50	886	100
PH322F1000MTL	100.0	4,500	8,000	19	0.56	75.5	8.5	266	30	443	50	886	100

PH421 with Motor Mounting Plate

PH421F0040MT	4.000	2,300	5,000	24	1.73	346	39	753	85	1,152	130	2,126	240
PH421F0040MTC	4.000	3,300	5,000	24	2.46	283	32	753	85	1,152	130	1,701	192
PH421F0040MTL	4.000	2,300	5,000	32	3.96	346	39	753	85	1,152	130	2,126	240
PH421F0050MT	5.000	2,700	6,000	24	1.55	328	37	753	85	1,152	130	2,126	240
PH421F0050MTC	5.000	3,700	6,000	24	2.28	289	33	753	85	1,152	130	2,126	240
PH421F0050MTL	5.000	2,700	6,000	32	3.78	328	37	753	85	1,152	130	2,126	240
PH421F0070MT	7.000	3,200	6,000	24	1.38	275	31	753	85	974	110	2,126	240
PH421F0070MTC	7.000	4,200	6,000	24	2.13	260	29	753	85	974	110	2,126	240
PH421F0070MTL	7.000	3,200	6,000	32	3.65	275	31	753	85	974	110	2,126	240
PH421F0100MT	10.00	3,500	6,000	24	1.30	186	21	531	60	886	100	1,772	200
PH421F0100MTC	10.00	4,500	6,000	24	2.05	183	21	531	60	886	100	1,772	200
PH421F0100MTL	10.00	3,500	6,000	32	3.57	186	21	531	60	886	100	1,772	200

PH422 with Motor Mounting Plate Continued Next Page

PH422F0160MT	16.00	3,700	6,500	19	0.72	237	27	797	90	1,152	130	2,126	240
PH422F0160MTL	16.00	3,700	6,500	24	1.40	237	27	797	90	1,152	130	2,126	240
PH422F0200MT	20.00	3,700	6,500	19	0.71	256	29	797	90	1,152	130	2,126	240
PH422F0200MTL	20.00	3,700	6,500	24	1.39	256	29	797	90	1,152	130	2,126	240
PH422F0250MT	25.00	4,000	7,000	19	0.65	254	29	797	90	1,152	130	2,126	240
PH422F0250MTL	25.00	4,000	7,000	24	1.34	254	29	797	90	1,152	130	2,126	240

¹⁾ Inertia based on maximum input. For lower inertia using smaller diameter input, contact STOBER.

²⁾ Based on input speed: n₁ = 2000 RPM

For torque at higher input speeds (M_{2NX}) solve the formula, where n₁ = Actual Input Speed.
$$M_{2NX} = \frac{M_{2N}}{\sqrt[3]{\frac{n_1}{2000}}}$$

³⁾ Maximum momentary torque for emergency stops or heavy shock load. Admissible stops per life of gearhead = 1,000 stops maximum.



"PH" Series ServoFit® Precision Planetary Gearhead Selection Data



Part Number (Gearhead + Input)	Exact Ratio i	Maximum Input Speed		Maximum Motor Shaft øD ⁶ mm	Input ¹⁾ Inertia J ₁ kgcm ²	Torsional Stiffness per arcmin		Output Torque					
		Continuous RPM (n ₁)	Cyclic			C ₂		Nominal ²⁾		Acceleration		Peak ³⁾	
						in.lbs.	Nm	M _{2N}	Nm	M _{2B}	Nm	M _{2PEAK}	Nm

PH422 with Motor Mounting Plate *Continued*

PH422F0280MT	28.00	4,500	8,000	19	0.60	222	25	797	90	1,152	130	2,126	240
PH422F0280MTL	28.00	4,500	8,000	24	1.27	222	25	797	90	1,152	130	2,126	240
PH422F0350MT	35.00	4,500	8,000	19	0.60	245	28	797	90	1,152	130	2,126	240
PH422F0350MTL	35.00	4,500	8,000	24	1.27	245	28	797	90	1,152	130	2,126	240
PH422F0400MT	40.00	4,500	8,000	19	0.58	215	24	797	90	1,152	130	2,126	240
PH422F0400MTL	40.00	4,500	8,000	24	1.25	215	24	797	90	1,152	130	2,126	240
PH422F0500MT	50.00	4,500	8,000	19	0.58	239	27	797	90	1,152	130	2,126	240
PH422F0500MTL	50.00	4,500	8,000	24	1.25	239	27	797	90	1,152	130	2,126	240
PH422F0700MT	70.00	4,500	8,000	19	0.58	237	27	797	90	974	110	2,126	240
PH422F0700MTL	70.00	4,500	8,000	24	1.25	237	27	797	90	974	110	2,126	240
PH422F1000MT	100.0	4,500	8,000	19	0.58	177	20	531	60	886	100	1,772	200
PH422F1000MTL	100.0	4,500	8,000	24	1.25	177	20	531	60	886	100	1,772	200

PH521 with Motor Mounting Plate

PH521F0040MT	4.000	2,200	5,000	32	3.65	868	98	1,860	210	2,835	320	4,915	555
PH521F0040MTC	4.000	3,200	5,000	32	5.87	648	73	1,860	210	2,447	276	3,059	345
PH521F0040MTL	4.000	2,200	5,000	38	6.68	868	98	1,860	210	2,835	320	4,915	555
PH521F0050MT	5.000	2,500	5,500	32	4.47	824	93	1,860	210	2,835	320	5,315	600
PH521F0050MTC	5.000	3,500	5,500	32	6.69	683	77	1,860	210	2,835	320	3,824	432
PH521F0050MTL	5.000	2,500	5,500	38	7.50	824	93	1,860	210	2,835	320	5,315	600
PH521F0070MT	7.000	3,000	6,000	32	3.97	682	77	1,860	210	2,392	270	5,315	600
PH521F0070MTC	7.000	4,000	6,000	32	6.21	627	71	1,860	210	2,392	270	5,315	600
PH521F0070MTL	7.000	3,000	6,000	38	7.02	682	77	1,860	210	2,392	270	5,315	600
PH521F0100MT	10.00	3,300	6,000	32	3.72	487	55	1,240	140	2,215	250	4,429	500
PH521F0100MTC	10.00	4,500	6,000	32	5.96	473	53	1,240	140	2,215	250	4,429	500
PH521F0100MTL	10.00	3,300	6,000	38	6.77	487	55	1,240	140	2,215	250	4,429	500

PH522 with Motor Mounting Plate *Continued Next Page*

PH522F0160 MT	16.00	3,300	6,000	24	1.54	575	65	1,860	210	2,835	320	4,915	555
PH522F0160MTC	16.00	4,300	6,000	24	2.26	562	63	1,860	210	2,835	320	4,915	555
PH522F0160MTL	16.00	3,300	6,000	32	3.76	575	65	1,860	210	2,835	320	4,915	555
PH522F0200MT	20.00	3,300	6,000	24	1.59	629	71	1,949	220	2,835	320	5,315	600
PH522F0200MTC	20.00	4,300	6,000	24	2.31	619	70	1,949	220	2,835	320	5,315	600
PH522F0200MTL	20.00	3,300	6,000	32	3.81	629	71	1,949	220	2,835	320	5,315	600
PH522F0250MT	25.00	3,700	6,500	24	1.47	625	71	1,949	220	2,835	320	5,315	600
PH522F0250MTC	25.00	4,500	6,500	24	2.19	619	70	1,949	220	2,835	320	5,315	600
PH522F0250MTL	25.00	3,700	6,500	32	3.69	625	71	1,949	220	2,835	320	5,315	600
PH522F0280MT	28.00	4,000	7,000	24	1.32	540	61	1,860	210	2,835	320	4,915	555
PH522F0280MTC	28.00	5,000	7,000	24	2.06	537	61	1,860	210	2,835	320	4,915	555
PH522F0280MTL	28.00	4,000	7,000	32	3.58	540	61	1,860	210	2,835	320	4,915	555
PH522F0350 MT	35.00	4,000	7,000	24	1.33	602	68	1,949	220	2,835	320	5,315	600
PH522F0350MTC	35.00	5,000	7,000	24	2.08	599	68	1,949	220	2,835	320	5,315	600
PH522F0350MTL	35.00	4,000	7,000	32	3.60	602	68	1,949	220	2,835	320	5,315	600
PH522F0400MT	40.00	4,000	7,000	24	1.27	517	58	1,860	210	2,835	320	4,915	555
PH522F0400MTC	40.00	5,000	7,000	24	2.02	515	58	1,860	210	2,835	320	4,915	555
PH522F0400MTL	40.00	4,000	7,000	32	3.54	517	58	1,860	210	2,835	320	4,915	555

Index of Symbols: **MT** — Motor adapter with TriAdapt® coupling; **L** — Large Input; **C** — ServoCool

See Page 72 for Options and Part Number Configuration.



"PH" Series ServoFit® Precision Planetary Gearhead Selection Data



PH

Part Number (Gearhead + Input)	Exact Ratio i	Maximum Input Speed		Maximum Motor Shaft øD ⁶ mm	Input ¹⁾ Inertia J ₁ kgcm ²	Torsional Stiffness per arcmin C ₂		Output Torque					
		Continuous RPM (n ₁)	Cyclic RPM (n ₂)			in.lbs.	Nm	Nominal ²⁾		Acceleration		Peak ³⁾	
								M _{2N}	M _{2B}	M _{2N}	M _{2PEAK}		

PH522 with Motor Mounting Plate *Continued*

PH522F0500MT	50.00	4,000	7,000	24	1.28	583	66	1,949	220	2,835	320	5,315	600
PH522F0500MTC	50.00	5,000	7,000	24	2.03	582	66	1,949	220	2,835	320	5,315	600
PH522F0500MTL	50.00	4,000	7,000	32	3.55	583	66	1,949	220	2,835	320	5,315	600
PH522F0700MT	70.00	4,000	7,000	24	1.28	581	66	1,860	210	2,392	270	5,315	600
PH522F0700MTC	70.00	5,000	7,000	24	2.02	580	66	1,860	210	2,392	270	5,315	600
PH522F0700 MTL	70.00	4,000	7,000	32	3.54	581	66	1,860	210	2,392	270	5,315	600
PH522F1000MT	100.0	4,000	7,000	24	1.27	459	52	1,240	140	2,215	250	4,429	500
PH522F1000MTC	100.0	5,000	7,000	24	2.02	459	52	1,240	140	2,215	250	4,429	500
PH522F1000MTL	100.0	4,000	7,000	32	3.54	459	52	1,240	140	2,215	250	4,429	500

PH721 with Motor Mounting Plate

PH721F0040MT	4.000	1,900	4,000	38	11.18	1,639	185	3,898	440	6,201	700	12,235	1,381
PH721F0040MTC	4.000	2,400	4,000	38	22.42	1,271	144	3,898	440	6,201	700	12,235	1,381
PH721F0040MTL	4.000	1,900	4,000	48	29.03	1,639	185	3,898	440	6,201	700	12,235	1,381
PH721F0050MT	5.000	2,200	5,000	38	9.34	1,630	184	3,898	440	6,201	700	12,401	1,400
PH721F0050MTC	5.000	3,000	5,000	38	20.58	1,377	155	3,898	440	6,201	700	12,401	1,400
PH721F0050MTL	5.000	2,200	5,000	48	27.19	1,630	184	3,898	440	6,201	700	12,401	1,400
PH721F0070MT	7.000	2,500	5,000	38	7.92	1,417	160	3,898	440	5,758	650	11,127	1,256
PH721F0070 MTC	7.000	3,500	5,000	38	18.82	1,286	145	3,898	440	5,758	650	11,127	1,256
PH721F0070MTL	7.000	2,500	5,000	48	26.22	1,417	160	3,898	440	5,758	650	11,127	1,256
PH721F0100MT	10.00	3,000	5,000	38	7.23	1,036	117	2,657	300	4,429	500	8,858	1,000
PH721F0100MTC	10.00	4,000	5,000	38	18.13	1,000	113	2,657	300	4,429	500	8,858	1,000
PH721F0100MTL	10.00	3,000	5,000	48	25.53	1,036	117	2,657	300	4,429	500	8,858	1,000

PH722 with Motor Mounting Plate *Continued Next Page*

PH722F0160MT	16.00	3,000	5,000	32	4.70	1,205	136	3,898	440	6,201	700	12,235	1,381
PH722F0160MTC	16.00	4,000	5,000	32	6.92	1,170	132	3,898	440	6,201	700	11,746	1,326
PH722F0160MTL	16.00	3,000	5,000	38	7.73	1,205	136	3,898	440	6,201	700	12,235	1,381
PH722F0200MT	20.00	3,000	5,000	32	4.59	1,326	150	3,898	440	6,201	700	12,401	1,400
PH722F0200MTC	20.00	4,000	5,000	32	6.81	1,299	147	3,898	440	6,201	700	12,401	1,400
PH722F0200MTL	20.00	3,000	5,000	38	7.61	1,326	150	3,898	440	6,201	700	12,401	1,400
PH722F0250MT	25.00	3,500	6,000	32	4.18	1,318	149	3,898	440	6,201	700	12,401	1,400
PH722F0250MTC	25.00	4,200	6,000	32	6.40	1,301	147	3,898	440	6,201	700	12,401	1,400
PH722F0250MTL	25.00	3,500	6,000	38	7.20	1,318	149	3,898	440	6,201	700	12,401	1,400
PH722F0280MT	28.00	3,700	6,500	32	3.86	1,160	131	3,898	440	6,201	700	12,235	1,381
PH722F0280MTC	28.00	4,500	6,500	32	6.10	1,149	130	3,898	440	6,201	700	12,235	1,381
PH722F0280MTL	28.00	3,700	6,500	38	6.90	1,160	131	3,898	440	6,201	700	12,235	1,381
PH722F0350MT	35.00	3,700	6,500	32	3.82	1,291	146	3,898	440	6,201	700	12,401	1,400
PH722F0350MTC	35.00	4,500	6,500	32	6.06	1,282	145	3,898	440	6,201	700	12,401	1,400
PH722F0350MTL	35.00	3,700	6,500	38	6.87	1,291	146	3,898	440	6,201	700	12,401	1,400
PH722F0400MT	40.00	3,700	6,500	32	3.67	1,121	127	3,898	440	6,201	700	12,235	1,381
PH722F0400MTC	40.00	4,700	6,500	32	5.91	1,116	126	3,898	440	6,201	700	12,235	1,381
PH722F0400MTL	40.00	3,700	6,500	38	6.71	1,121	127	3,898	440	6,201	700	12,235	1,381
PH722F0500MT	50.00	3,700	6,500	32	3.65	1,259	142	3,898	440	6,201	700	12,401	1,400
PH722F0500MTC	50.00	4,700	6,500	32	5.89	1,255	142	3,898	440	6,201	700	12,401	1,400
PH722F0500MTL	50.00	3,700	6,500	38	6.70	1,259	142	3,898	440	6,201	700	12,401	1,400

¹⁾ Inertia based on maximum input. For lower inertia using smaller diameter input, contact STOBER.

²⁾ Based on input speed: n₁ = 2000 RPM

For torque at higher input speeds (M_{2NX}) solve the formula, where n₁ = Actual Input Speed.
$$M_{2NX} = \frac{M_{2N}}{\sqrt[3]{\frac{n_1}{2000}}}$$

³⁾ Maximum momentary torque for emergency stops or heavy shock load. Admissible stops per life of gearhead = 1,000 stops maximum.



"PH" Series ServoFit® Precision Planetary Gearhead Selection Data



Part Number (Gearhead + Input)	Exact Ratio i	Maximum Input Speed		Maximum Motor Shaft øD ⁶ mm	Input ¹⁾ Inertia J ₁ kgcm ²	Torsional Stiffness per arcmin		Output Torque					
		Continuous RPM (n _i)	Cyclic RPM (n _i)			C ₂		Nominal ²⁾ M _{2N}		Acceleration M _{2B}		Peak ³⁾ M _{2PEAK}	
						in.lbs.	Nm	in.lbs.	Nm	in.lbs.	Nm	in.lbs.	Nm

PH722 with Motor Mounting Plate *Continued*

PH722F0700MT	70.00	3,700	6,500	32	3.63	1,254	142	3,898	440	5,758	650	11,127	1,256
PH722F0700MTC	70.00	4,700	6,500	32	5.87	1,252	141	3,898	440	5,758	650	11,127	1,256
PH722F0700MTL	70.00	3,700	6,500	38	6.68	1,254	142	3,898	440	5,758	650	11,127	1,256
PH722F1000MT	100.0	3,700	6,500	32	3.63	990	112	2,657	300	4,429	500	8,858	1,000
PH722F1000MTC	100.0	4,700	6,500	32	5.87	989	112	2,657	300	4,429	500	8,858	1,000
PH722F1000MTL	100.0	3,700	6,500	38	6.67	990	112	2,657	300	4,429	500	8,858	1,000

PH821 with Motor Mounting Plate

PH821F0040MT	4.000	1,500	3,500	48	48.88	5,315	600	7,086	800	14,173	1,600	22,752	2,569
PH821F0040MTC	4.000	2,200	3,500	48	70.14	3,527	398	7,086	800	14,173	1,600	20,477	2,312
PH821F0050MT	5.000	1,700	4,000	48	39.89	4,872	550	8,858	1,000	15,059	1,700	28,346	3,200
PH821F0050 MTC	5.000	2,500	4,000	48	61.15	3,755	424	8,858	1,000	15,059	1,700	25,596	2,890
PH821F0070MT	7.000	2,000	4,000	48	32.00	4,075	460	8,858	1,000	14,173	1,600	24,900	2,811
PH821F0070MTC	7.000	3,200	4,000	48	53.73	3,546	400	8,858	1,000	14,173	1,600	24,900	2,811
PH821F0100MT	10.00	2,500	4,000	48	28.19	2,790	315	7,086	800	10,630	1,200	21,259	2,400
PH821F0100MTC	10.00	3,700	4,500	48	49.92	2,657	300	7,086	800	10,630	1,200	21,259	2,400

PH822 with Motor Mounting Plate

PH822F0160MT	16.00	2,500	4,500	38	11.13	3,271	369	9,744	1,100	17,716	2,000	28,346	3,200
PH822F0160MTC	16.00	3,250	4,500	38	22.37	3,157	356	9,744	1,100	17,716	2,000	28,346	3,200
PH822F0160MTL	16.00	2,500	4,500	48	28.98	3,271	369	9,744	1,100	17,716	2,000	28,346	3,200
PH822F0200MT	20.00	2,500	4,500	38	10.57	3,565	402	11,073	1,250	17,716	2,000	28,346	3,200
PH822F0200MTC	20.00	3,300	4,500	38	21.80	3,477	393	11,073	1,250	17,716	2,000	28,346	3,200
PH822F0200MTL	20.00	2,500	4,500	48	28.42	3,565	402	11,073	1,250	17,716	2,000	28,346	3,200
PH822F0250 MT	25.00	3,000	5,500	38	9.05	3,524	398	11,073	1,250	17,716	2,000	28,346	3,200
PH822F0250MTC	25.00	3,800	5,500	38	20.29	3,469	392	11,073	1,250	17,716	2,000	28,346	3,200
PH822F0250MTL	25.00	3,000	5,500	48	26.91	3,524	398	11,073	1,250	17,716	2,000	28,346	3,200
PH822F0280MT	28.00	3,300	6,000	38	7.97	3,160	357	9,744	1,100	17,716	2,000	28,346	3,200
PH822F0280MTC	28.00	4,000	6,000	38	18.87	3,116	352	9,744	1,100	17,716	2,000	28,346	3,200
PH822F0280MTL	28.00	3,300	6,000	48	26.27	3,160	357	9,744	1,100	17,716	2,000	28,346	3,200
PH822F0350MT	35.00	3,300	6,000	38	7.78	3,480	393	11,073	1,250	17,716	2,000	28,346	3,200
PH822F0350MTC	35.00	4,000	6,000	38	18.69	3,445	389	11,073	1,250	17,716	2,000	28,346	3,200
PH822F0350MTL	35.00	3,300	6,000	48	26.09	3,480	393	11,073	1,250	17,716	2,000	28,346	3,200
PH822F0400MT	40.00	3,300	6,000	38	7.25	3,024	341	9,744	1,100	17,007	1,920	28,346	3,200
PH822F0400MTC	40.00	4,300	6,000	38	18.15	3,004	339	9,744	1,100	17,007	1,920	28,346	3,200
PH822F0400MTL	40.00	3,300	6,000	48	25.55	3,024	341	9,744	1,100	17,007	1,920	28,346	3,200
PH822F0500MT	50.00	3,300	6,000	38	7.16	3,373	381	11,073	1,250	17,716	2,000	28,346	3,200
PH822F0500MTC	50.00	4,300	6,000	38	18.06	3,357	379	11,073	1,250	17,716	2,000	28,346	3,200
PH822F0500MTL	50.00	3,300	6,000	48	25.46	3,373	381	11,073	1,250	17,716	2,000	28,346	3,200
PH822F0700MT	70.00	3,300	6,000	38	7.08	3,425	387	8,858	1,000	14,173	1,600	24,900	2,811
PH822F0700MTC	70.00	4,300	6,000	38	17.99	3,417	386	8,858	1,000	14,173	1,600	24,900	2,811
PH822F0700MTL	70.00	3,300	6,000	48	25.39	3,425	387	8,858	1,000	14,173	1,600	24,900	2,811
PH822F1000MT	100.0	3,300	6,000	38	7.05	2,623	296	7,086	800	10,630	1,200	21,259	2,400
PH822F1000MTC	100.0	4,300	6,000	38	17.95	2,621	296	7,086	800	10,630	1,200	21,259	2,400
PH822F1000MTL	100.0	3,300	6,000	48	25.35	2,623	296	7,086	800	10,630	1,200	21,259	2,400

Index of Symbols: **MT** — Motor adapter with TriAdapt® coupling; **L** — Large Input; **C** — ServoCool

See Page 72 for Options and Part Number Configuration.



"PH" Series ServoFit® Precision Planetary Gearhead Selection Data



Part Number (Gearhead + Input)	Exact Ratio i	Maximum Input Speed		Maximum Motor Shaft øD ⁶ mm	Input ¹⁾ Inertia J ₁ kgcm ²	Torsional Stiffness per arcmin		Output Torque					
		Continuous RPM (n ₁)	Cyclic			C ₂		Nominal ²⁾		Acceleration		Peak ³⁾	
						in.lbs.	Nm	M _{2N}	Nm	M _{2B}	Nm	M _{2PEAK}	Nm

PH932 with Motor Mounting Plate

PH932F0120 MT	12.00	1,800	3,000	48	74.94	10,980	1,240	26,574	3,000	40,818	4,608	65,527	7,397
PH932F0120 MTC	12.00	2,700	3,000	48	95.95	9,836	1,110	26,574	3,000	40,818	4,608	65,527	7,397
PH932F0120 MTL	12.00	1,800	3,000	60	97.89	10,641	1,201	26,574	3,000	40,818	4,608	65,527	7,397
PH932F0160 MT	16.00	2,200	3,500	48	44.87	10,735	1,212	26,574	3,000	44,290	5,000	87,369	9,863
PH932F0160 MTC	16.00	2,900	3,500	48	65.88	10,089	1,139	26,574	3,000	44,290	5,000	87,369	9,863
PH932F0160 MTL	16.00	2,200	3,500	60	67.82	10,550	1,191	26,574	3,000	44,290	5,000	87,369	9,863
PH932F0180 MT	18.00	1,800	3,000	48	68.89	10,054	1,135	26,574	3,000	39,861	4,500	79,722	9,000
PH932F0180 MTC	18.00	2,700	3,000	48	89.91	9,599	1,084	26,574	3,000	39,861	4,500	79,722	9,000
PH932F0180 MTL	18.00	1,800	3,000	60	91.84	9,925	1,120	26,574	3,000	39,861	4,500	79,722	9,000
PH932F0200 MT	20.00	2,500	4,000	48	37.23	10,520	1,188	26,574	3,000	44,290	5,000	88,580	10,000
PH932F0200 MTC	20.00	3,300	4,000	48	58.25	10,114	1,142	26,574	3,000	44,290	5,000	88,580	10,000
PH932F0200 MTL	20.00	2,500	4,000	60	60.18	10,406	1,175	26,574	3,000	44,290	5,000	88,580	10,000
PH932F0240 MT	24.00	2,200	3,500	48	41.47	9,961	1,125	26,574	3,000	39,861	4,500	79,722	9,000
PH932F0240 MTC	24.00	2,700	3,000	48	62.48	9,705	1,096	26,574	3,000	39,861	4,500	79,722	9,000
PH932F0240 MTL	24.00	2,200	3,500	60	64.42	9,889	1,116	26,574	3,000	39,861	4,500	79,722	9,000
PH932F0280 MT	28.00	2,800	4,500	48	30.69	10,157	1,147	26,574	3,000	44,290	5,000	88,580	10,000
PH932F0280 MTC	28.00	4,000	4,500	48	52.18	9,926	1,121	26,574	3,000	44,290	5,000	88,580	10,000
PH932F0280 MTL	28.00	2,800	4,500	60	58.71	10,102	1,140	26,574	3,000	44,290	5,000	88,580	10,000
PH932F0300 MT	30.00	2,500	4,000	48	35.05	9,878	1,115	26,574	3,000	39,861	4,500	79,722	9,000
PH932F0300 MTC	30.00	2,700	3,000	48	56.07	9,715	1,097	26,574	3,000	39,861	4,500	79,722	9,000
PH932F0300 MTL	30.00	2,500	4,000	60	58.00	9,833	1,110	26,574	3,000	39,861	4,500	79,722	9,000
PH932F0320 MT	32.00	2,800	4,500	48	29.38	9,847	1,112	26,574	3,000	40,818	4,608	88,580	10,000
PH932F0320 MTC	32.00	4,000	4,500	48	50.87	9,680	1,093	26,574	3,000	40,818	4,608	88,580	10,000
PH932F0320 MTL	32.00	2,800	4,500	60	57.40	9,808	1,107	26,574	3,000	40,818	4,608	88,580	10,000
PH932F0400 MT	40.00	2,800	4,500	48	27.21	9,362	1,057	23,810	2,688	40,818	4,608	88,580	10,000
PH932F0400 MTC	40.00	4,000	4,500	48	48.70	9,265	1,046	23,810	2,688	40,818	4,608	88,580	10,000
PH932F0400 MTL	40.00	2,800	4,500	60	55.23	9,339	1,054	23,810	2,688	40,818	4,608	88,580	10,000
PH932F0420 MT	42.00	2,800	4,500	48	29.58	9,733	1,099	26,574	3,000	39,861	4,500	79,722	9,000
PH932F0420 MTC	42.00	4,000	4,500	48	51.07	9,637	1,088	26,574	3,000	39,861	4,500	79,722	9,000
PH932F0420 MTL	42.00	2,800	4,500	60	57.60	9,710	1,096	26,574	3,000	39,861	4,500	79,722	9,000
PH932F0480 MT	48.00	2,800	4,500	48	28.53	9,604	1,084	26,574	3,000	39,861	4,500	79,722	9,000
PH932F0480 MTC	48.00	4,000	4,500	48	50.02	9,533	1,076	26,574	3,000	39,861	4,500	79,722	9,000
PH932F0480 MTL	48.00	2,800	4,500	60	56.55	9,587	1,082	26,574	3,000	39,861	4,500	79,722	9,000
PH932F0600 MT	60.00	2,800	4,500	48	26.67	9,393	1,060	26,574	3,000	39,861	4,500	79,722	9,000
PH932F0600 MTC	60.00	4,000	4,500	48	48.16	9,349	1,055	26,574	3,000	39,861	4,500	79,722	9,000
PH932F0600 MTL	60.00	2,800	4,500	60	54.68	9,383	1,059	26,574	3,000	39,861	4,500	79,722	9,000

PHV933 with Motor Mounting Plate

PHV933F0610 MT	61.00	2,500	4,500	38	49.32	7,531	850	22,145	2,500	37,647	4,250	79,722	9,000
PHV933F0610 MTC	61.00	3,200	4,500	38	53.32	7,488	845	22,145	2,500	37,647	4,250	79,722	9,000
PHV933F0610 MTL	61.00	2,500	4,500	48	67.17	7,531	850	22,145	2,500	37,647	4,250	79,722	9,000
PHV933F0910 MT	91.00	2,500	4,500	38	45.51	7,427	838	22,145	2,500	37,647	4,250	79,722	9,000
PHV933F0910 MTC	91.00	3,200	4,500	38	51.19	7,403	836	22,145	2,500	37,647	4,250	79,722	9,000
PHV933F0910 MTL	91.00	2,500	4,500	48	63.81	7,427	838	22,145	2,500	37,647	4,250	79,722	9,000
PHV933F1210 MT	121.00	2,500	4,500	38	44.12	7,131	805	22,145	2,500	37,647	4,250	79,722	9,000
PHV933F1210 MTC	121.00	3,200	4,500	38	49.81	7,119	804	22,145	2,500	37,647	4,250	79,722	9,000
PHV933F1210 MTL	121.00	2,500	4,500	48	62.42	7,131	805	22,145	2,500	37,647	4,250	79,722	9,000

¹⁾ Inertia based on maximum input. For lower inertia using smaller diameter input, contact STOBER.

²⁾ Based on input speed: n₁ = 2000 RPM

For torque at higher input speeds (M_{2NX}) solve the formula, where n₁ = Actual Input Speed.
$$M_{2NX} = \frac{M_{2N}}{\sqrt[3]{\frac{n_1}{2000}}}$$

³⁾ Maximum momentary torque for emergency stops or heavy shock load. Admissible stops per life of gearhead = 1,000 stops maximum.



"PH" Series ServoFit® Precision Planetary Gearhead Selection Data



Part Number (Gearhead + Input)	Exact Ratio i	Maximum Input Speed		Maximum Motor Shaft øD ⁶ mm	Input ¹⁾ Inertia J ₁ kgcm ²	Torsional Stiffness per arcmin C ₂		Output Torque					
		Continuous RPM (n ₁)	Cyclic			in.lbs.	Nm	Nominal ²⁾ M _{2N}		Acceleration M _{2B}		Peak ³⁾ M _{2PEAK}	
								in.lbs.	Nm	in.lbs.	Nm	in.lbs.	Nm

PH1032 with Motor Mounting Plate

PH1032F0180 MT	18.00	1,800	3,000	48	72.04	15,752	1,778	40,818	4,608	61,226	6,912	98,290	11,096
PH1032F0180 MTC	18.00	2,500	3,000	48	93.06	14,665	1,656	40,818	4,608	61,226	6,912	98,290	11,096
PH1032F0180 MTL	18.00	1,800	3,000	60	94.99	15,438	1,743	40,818	4,608	61,226	6,912	98,290	11,096
PH1032F0240 MT	24.00	2,200	3,500	48	43.24	15,526	1,753	40,818	4,608	66,435	7,500	131,053	14,795
PH1032F0240 MTC	24.00	2,700	3,500	48	64.25	14,913	1,684	40,818	4,608	66,435	7,500	131,053	14,795
PH1032F0240 MTL	24.00	2,200	3,500	60	66.19	15,353	1,733	40,818	4,608	66,435	7,500	131,053	14,795
PH1032F0300 MT	30.00	2,500	4,000	48	36.19	15,325	1,730	44,290	5,000	66,435	7,500	132,870	15,000
PH1032F0300 MTC	30.00	3,200	4,000	48	57.20	14,937	1,686	44,290	5,000	66,435	7,500	132,870	15,000
PH1032F0300 MTL	30.00	2,500	4,000	60	59.14	15,217	1,718	44,290	5,000	66,435	7,500	132,870	15,000
PH1032F0420 MT	42.00	2,800	4,500	48	30.16	14,978	1,691	44,290	5,000	66,435	7,500	132,870	15,000
PH1032F0420 MTC	42.00	4,000	4,500	48	51.65	14,754	1,666	44,290	5,000	66,435	7,500	132,870	15,000
PH1032F0420 MTL	42.00	2,800	4,500	60	58.18	14,925	1,685	44,290	5,000	66,435	7,500	132,870	15,000
PH1032F0480 MT	48.00	2,800	4,500	48	28.98	14,676	1,657	40,818	4,608	61,226	6,912	132,870	15,000
PH1032F0480 MTC	48.00	4,000	4,500	48	50.46	14,510	1,638	40,818	4,608	61,226	6,912	132,870	15,000
PH1032F0480 MTL	48.00	2,800	4,500	60	56.99	14,637	1,652	40,818	4,608	61,226	6,912	132,870	15,000
PH1032F0600 MT	60.00	2,800	4,500	48	26.95	14,189	1,602	35,715	4,032	61,226	6,912	132,870	15,000
PH1032F0600 MTC	60.00	4,000	4,500	48	48.44	14,090	1,591	35,715	4,032	61,226	6,912	132,870	15,000
PH1032F0600 MTL	60.00	2,800	4,500	60	54.96	14,166	1,599	35,715	4,032	61,226	6,912	132,870	15,000

PHV1033 with Motor Mounting Plate

PHV1033F0610 MT	61.00	2,500	4,500	48	146.08	12,139	1,370	35,432	4,000	66,435	7,500	132,870	15,000
PHV1033F0610 MTC	61.00	3,000	4,500	48	165.05	12,078	1,364	35,432	4,000	66,435	7,500	132,870	15,000
PHV1033F0910 MT	91.00	2,500	4,500	48	120.21	11,888	1,342	35,432	4,000	66,435	7,500	132,870	15,000
PHV1033F0910 MTC	91.00	3,000	4,500	48	142.68	11,858	1,339	35,432	4,000	66,435	7,500	132,870	15,000

Index of Symbols: **MT** — Motor adapter with TriAdapt® coupling; **L** — Large Input; **C** — ServoCool

See Page 72 for Options and Part Number Configuration.



"PH" Series ServoFit® Precision Planetary Gearhead Dimensional Data



Drawing for Units
PH321 thru PH1033

P
H

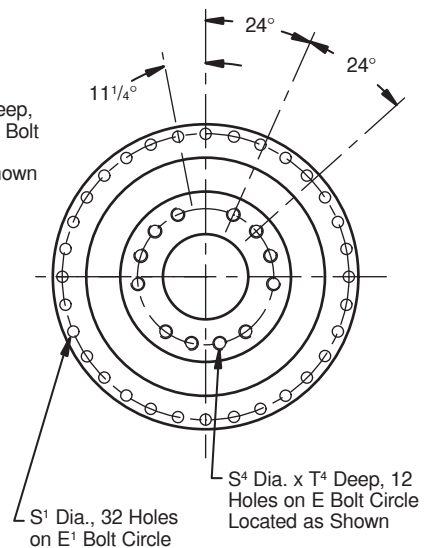
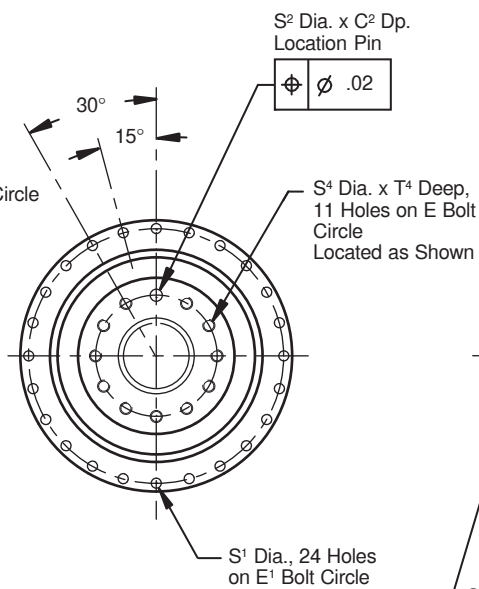
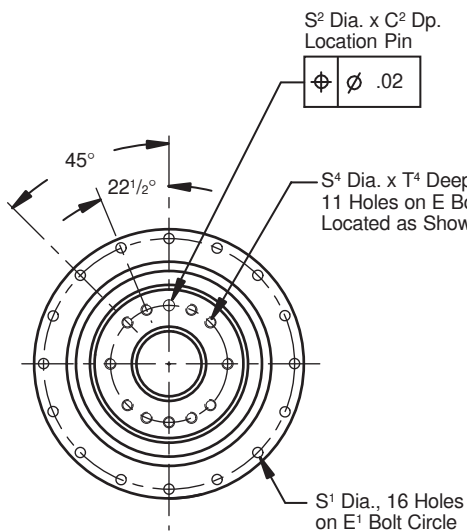
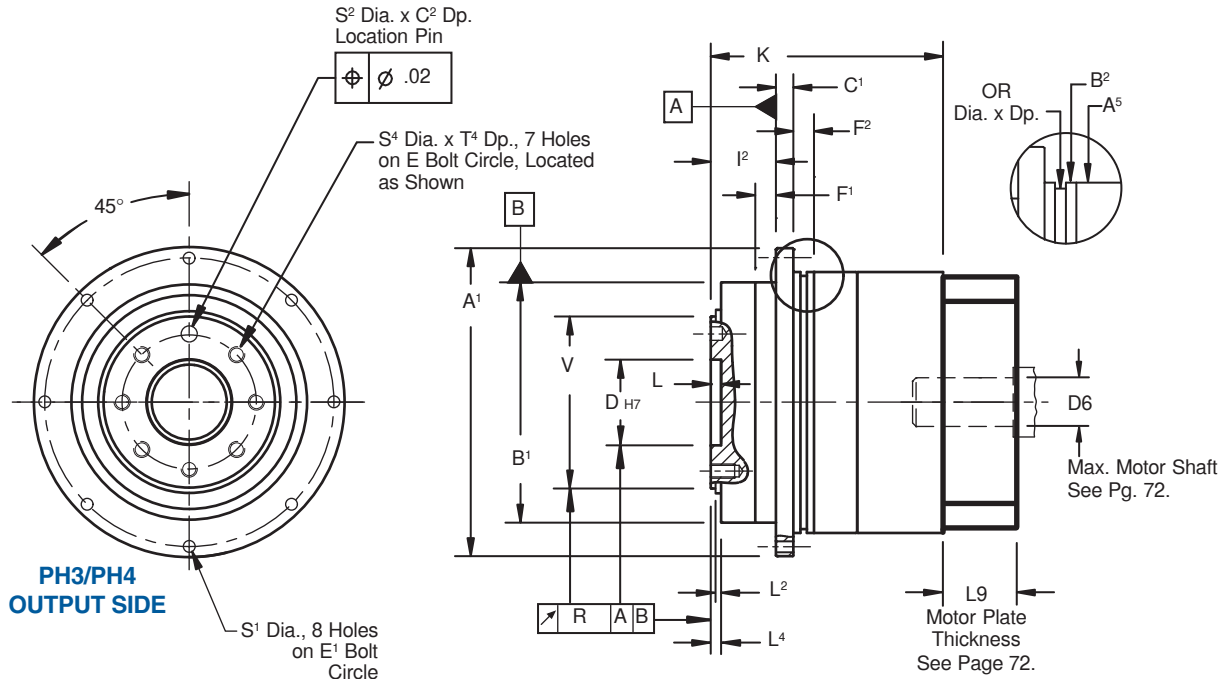



"PH" Series ServoFit® Precision Planetary Gearhead Dimensional Data



Table No. 1 "PH" Series – Gearhead with Motor Plate – Dimensions (mm)

Unit	A ¹ h7	B ¹ h7	B ² h7	C ¹	C ²	D H7	E	E ¹	F ¹	F ²	I ²	L	L ²	L ⁴	OR
PH321/PH322	86 +.000/-0.035	64 +.000/-0.030	70 * +.000/-0.030	4	3	20 +.021/-0	31.5	79	7	8	19.5	4	3	3.5	65x2
PH421/PH422	118 +.000/-0.035	90 +.000/-0.035	95 +.000/-0.035	7	7	31.5 +.025/-0	50	109	10	10	30	6	6	6	90x3
PH521/PH522	145 +.000/-0.040	110 +.000/-0.035	120 * +.000/-0.035	8	7	40 +.025/-0	63	135	10	12	29	6	6	6	110x3
PH721/PH722	179 +.000/-0.040	140 +.000/-0.040	152 +.000/-0.040	10	7	50 +.025/-0	80	168	12	12	38	6	6	6	145x3
PH821/PH822	247 +.000/-0.046	200 +.000/-0.046	212 +.000/-0.046	12	10	80 +.030/-0	125	233	15	15	50	8	8	8	200x5
PH932/PHV933	300 —	255 +.000/-0.052	255 +.000/-0.052	18	—	90 +.035/-0	140	280	20	33	66	12	11	12	238x5
PH1032/PHV1033	330 —	285 +.000/-0.057	285 +.000/-0.052	20	—	95 +.035/-0	160	310	20	20	75	10	15	15	270x6

* Not applicable for PH322 and PH522.

Table No. 2 "PH" Series – Dimensions (mm)

Unit	R	S ¹	S ² H7	S ⁴	T ⁴	V h7
PH321/PH322	.020	4.5	5 +.012/-0.000	M5	7	40 +.000/-0.025
PH421/PH422	.020	5.5	6 +.012/-0.000	M6	11	63 +.000/-0.030
PH521/PH522	.020	5.5	6 +.012/-0.000	M6	11	80 +.000/-0.030
PH721/PH722	.025	6.6	8 +.015/-0.000	M8	14	100 +.000/-0.035
PH821/PH822	.030	9	10 +.015/-0.000	M10	18	160 +.000/-0.040
PH932/PHV933	.030	13.5	—	M16	24	180 +.000/-0.040
PH1032/PHV1033	.040	13.5	—	M20	30	200 +.000/-0.046



Typical 2 Stage Configuration



Typical ServoCool

Part No. Example
PH821F0050MTC

Table No. 3 "PH" Series – Dimensions (mm)

Standard			ServoCool		
Unit	A ⁵	K	Unit	A ⁵	K
PH321	70	80.5	—		
PH322	55	104	—		
PH421	95	99	PH421_C	98	122.5
PH422	72	146.5	—		
PH521	120	110	PH521_C	115	138
PH522	98	159.5	PH522_C	98	183
PH721	152	138	PH721_C	145	168
PH722	115	190	PH722_C	115	218
PH821	212	183	PH821_C	190	231
PH822	145	251	PH822_C	145	281
PH932	190	349.5	PH932_C	190	397.5
PHV933	152	269.5	PHV933_C	145	299.5
PH1032	190	366	PH1032_C	190	414
PHV1033	212	307	PHV1033_C	190	355

If a planetary gearhead is to be mounted from "B²" side, specify when ordering. For proper mounting the paint must be eliminated and the tolerance held on that surface.



Side "B²" mounting is not possible with the Large Input.

See Page 72 for Options and Part Number Configuration.



"PH" Series – Large Input ServoFit® Precision Planetary Gearhead Dimensional Data



Drawing for Units
PH321_L thru PH1032_L

P
H

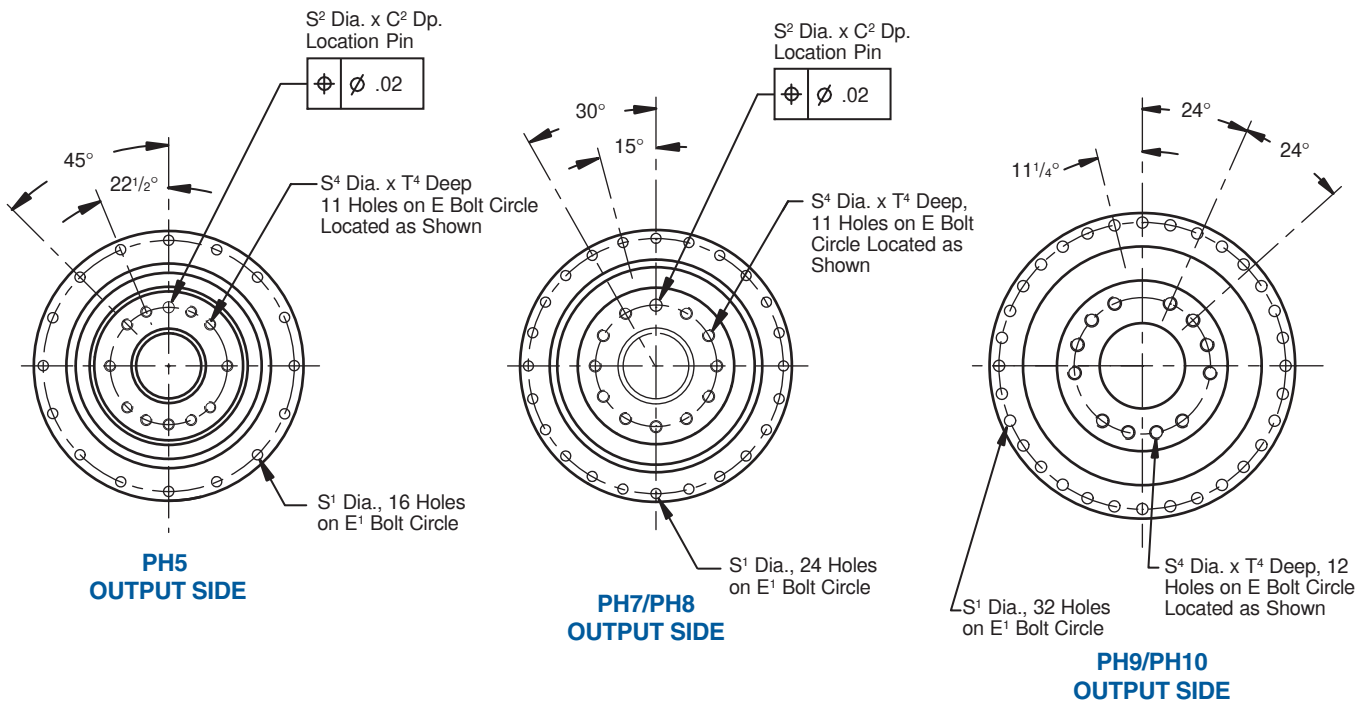
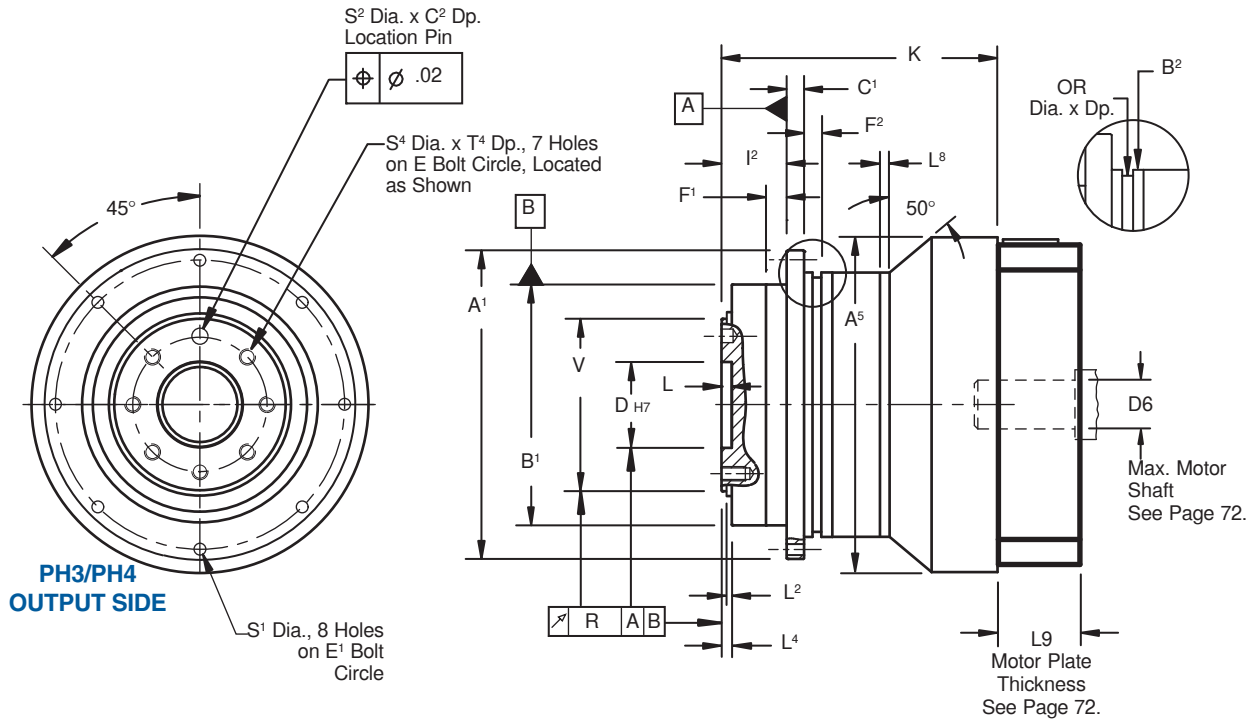



"PH" Series – Large Input ServoFit® Precision Planetary Gearhead Dimensional Data



Table No. 1

"PH" Series – Gearhead with Motor Plate – Dimensions (mm)

Unit	A ¹ h7	B ¹ h7	B ² h7	C ¹	C ²	D H7	E	E ¹	F ¹	F ²	I ²	L	L ²	L ⁴	L ⁸
PH321/PH322_L	86 +.000/-0.035	64 +.000/-0.030	70 * +.000/-0.030	4	3	20 +.021/-0	31.5	79	7	8	19.5	4	3	3.5	5
PH421/PH422_L	118 +.000/-0.035	90 +.000/-0.035	95 +.000/-0.035	7	7	31.5 +.025/-0	50	109	10	10	30	6	6	6	5
PH521/PH522_L	145 +.000/-0.040	110 +.000/-0.035	120 * +.000/-0.035	8	7	40 +.025/-0	63	135	10	12	29	6	6	6	5
PH721/PH722_L	179 +.000/-0.040	140 +.000/-0.040	152 +.000/-0.040	10	7	50 +.025/-0	80	168	12	12	38	6	6	6	5
PH822_L	247 +.000/-0.046	200 +.000/-0.046	212 +.000/-0.046	12	10	80 +.030/-0	125	233	15	15	50	8	8	8	5
PH932/PHV933_L	300 —	255 +.000/-0.052	255 +.000/-0.052	18	—	90 +.035/-0	140	280	20	33	66	12	11	12	5
PH1032_L	330 —	285 +.000/-0.057	285 +.000/-0.052	20	—	95 +.035/-0	160	310	20	20	75	10	15	15	3

* Not applicable for PH322 and PH522.

Table No. 2

"PH" Series – Large Input – Dimensions (mm)

Unit	OR	R	S ¹	S ² H7	S ⁴	T ⁴	V h7
PH321/PH322_L	65x2	.020	4.5	5 +.012/-0.000	M5	7	40 +.000/-0.025
PH421/PH422_L	90x3	.020	5.5	6 +.012/-0.000	M6	10	63 +.000/-0.030
PH521/PH522_L	110x3	.020	5.5	6 +.012/-0.000	M6	11	80 +.000/-0.030
PH721/PH722_L	145x3	.025	6.6	8 +.015/-0.000	M8	14	100 +.000/-0.035
PH822_L	200x5	.030	9	10 +.015/-0.000	M10	18	160 +.000/-0.040
PH932/PHV933_L	238x5	.030	13.5	—	M16	24	180 +.000/-0.040
PH1032_L	270x6	.040	13.5	—	M20	30	200 +.000/-0.046

Table No. 3

Unit	A ⁵	K
PH321_L	95	80.5
PH322_L	72	104
PH421_L	120	99
PH422_L	98	146.5
PH521_L	152	110
PH522_L	115	159.5
PH721_L	212	138
PH722_L	145	190
PH822_L	190	251
PH932_L	225	349.5
PHV933_L	212	269.5
PH1032_L	225	366



Typical 2 Stage Configuration

Part No. Example
PH421F0050MTL

See Page 72 for Options and Part Number Configuration.

"PHA" Series – Advanced ServoFit® Precision Planetary Gearhead Performance Specifications



P
H
A

Size			PHA321 PHA322	PHA421 PHA422	PHA521 PHA522	PHA721 PHA722	PHA821 PHA822	PHA932 PHVA933	PHA1032 PHVA1033
Acceleration Torque Max.	M _{2B}	in.lbs. Nm	575 65	1,150 130	2,832 320	6,195 700	17,700 2,000	44,290 5,000	66,375 7,500
Output Torque Nominal ¹⁾	M _{2N}	in.lbs. Nm	398 45	796 90	1,947 220	3,894 440	11,062 1,250	26,574 3,000	44,290 5,000
Input Speed Maximum	n _{1MAX}	Continuous Cyclic	3,800 4,500 6,000 8,000	3,500 4,500 6,000 8,000	3,300 4,000 6,000 7,000	3,000 3,700 5,000 6,500	2,500 3,300 4,000 6,000	2,800 2,500 4,500 4,500	2,800 2,500 4,500 4,500
ServoCool Input RPM Max.	n _{1MAX}	Continuous Cyclic	— —	4,500 — 6,000 —	4,500 5,000 6,000 7,000	4,000 4,700 5,000 6,500	3,700 4,300 4,500 6,000	4,000 3,200 4,500 4,500	4,000 3,000 4,500 4,500
Torsional Backlash ²⁾	Δφ	arcmin	≤2	≤1	≤1	≤1	≤1	≤1	≤1
Torsional Stiffness	C ₂	in.lbs./arcmin Nm/arcmin	≤106 ≤12	≤292 ≤33	≤708 ≤80	≤1,371 ≤155	≤3,752 ≤424	≤10,980 ≤1,240	≤15,752 ≤1,778
Axial Load Maximum	F _{2MAX}	lbs. N	371 1,650	484 2,150	934 4,150	1,384 6,150	2,260 10,050	7,425 33,000	11,250 50,000
Tilting Moment Maximum	M _{2K}	in.lbs. Nm	885 100	2,301 260	3,894 440	13,275 1,500	30,975 3,500	66,375 7,500	77,880 8,800
Tilting Stiffness	C _{2K}	in.lbs./arcmin Nm/arcmin	— —	1,416 160	2,655 300	4,425 500	13,718 1,550	66,375 7,500	84,075 9,500
Efficiency (at Nominal Torque)	η	%	96% 94%	96% 94%	96% 94%	96% 94%	96% 94%	96% 94%	94% 92%
Weight	m	pounds kg	4 1.8	9 10 3.9 4.6	15 18 6.6 8.1	27 32 12.3 14.6	76 88 34.6 39.8	166 147 75.2 66.6	200 198 90.6 90
Noise Level ⁴⁾	L _{PA}	dB(A)	≤61	≤62	≤63	≤64	≤65	≤65	≤65
Balance Quality	Q 2.5 (Quality Class-2.5 millimeters per second)								
Lubrication	Synthetic Oil (ISO VG 150)								
Degree of Protection	IP65								
Mounting Position	Unrestricted								
Ambient Temperature	0° C to +40°C (104° F) [Unit temperature ≤ 90° C Max.]								
Finish	Black (RAL 9005)								
Lifetime ⁵⁾	L _h	hours	L _h > 10,000 hours if M _{2K} /M _{2A} < 1.25 and > 1.00 L _h > 20,000 hours if M _{2K} /M _{2A} > 1.25 and < 1.50 L _h > 30,000 hours if M _{2K} /M _{2A} > 1.5						
Warranty	5 Year Limited (2 Years on normal wear items: bearings, seals, etc.)								

¹⁾ Ratings based on input speed (n₁) of 2000 RPM.

For torque at higher input speeds (M_{2NX}) solve the formula, where n₁ = Actual Input Speed. $M_{2NX} = \sqrt[3]{\frac{M_{2N} \cdot n_1}{2000}}$

²⁾ Tested at 1.5% of nominal torque and recorded on the output side of the gearhead.

³⁾ Rating based on output speed (n₂) of 100 RPM. For values at other speeds see Page 87.

⁴⁾ Measurement at one (1) meter distance with input speed (n₁) of 3000 RPM.

⁵⁾ M_{2A} equals actual tilting moment of the application. See Page 87 for calculation details.

WARNING: In order to insure that the specified torque ratings are attained, it is essential to use a grade 12.9 fastener on all output connections.

Refer to Page 302 for ServoFit Precision Planetary Gearhead Selection Procedure.



"PHA" Series – Advanced ServoFit® Precision Planetary Gearhead Features

The "PHA" Series ServoFit Precision Planetary Gearheads are designed for high demands of torsional stiffness and tilting rigidity. The "PHA" series is well suited where a smooth, precise, reliable drive is needed. All units are lubricated for life with synthetic oil and sealed on the smallest diameters possible with FKM radial oil seals to IP65 standards — reduces friction and prevents heat build up, increases efficiency, and prevents lubricant contamination for long life.

Some features are:

- Readily Attaches to Any Servo Motor
- Superior Torsional Stiffness
- 90-96% Efficiency
- Excellent Axial Load Capacity
- ≤ 1 arc minute backlash
- ISO Output Flange for Coupling Free Mounting
- Advanced HeliCamber Gear Technology
- 5 Year Limited Warranty (2 Year on bearings, seals, etc.)
- Wide Selection of IEC, NEMA, or Customized* Motor Plates
- Ground and honed gearing

* Maximum 10 working day for custom motor plates.

The output flange dimensions are ISO 9409 and allow easy mounting to rotary or indexing tables, pinions, timing belt pulleys, transmission shafting, etc., without using a coupling.

Ring gear machined integral to the housing — not welded or pressed in

Helical gears made with the proven experience of HeliCamber® gear technology provides the highest running smoothness — ensuring backlash stability and extremely quiet operation.

Single piece high tensile steel housing provides greater concentricity and more precise alignment — ensuring high running accuracy and precision.

Gears are case hardened to 61 Rockwell "C" and ground and honed for maximum accuracy.

Blind pilot hole

FKM double-lip radial oil seals for continuous duty applications and very good chemical resistance.

Oversized tapered roller bearings and shafts for high radial load capacity and superior torsional stiffness

Backlash ≤ 1 arcminute — Precision selection of parts ensure optimal performance without binding gear teeth — resulting in a more accurate and smooth direct drive and very low backlash

Adapter bushings fit all motor shafts — no key required

Balanced clamp coupling for smooth operation at high speeds.

The FlexiAdapt® motor shaft adapter system allows easy and accurate installation of motor in minutes — no special tools required.

The FlexiAdapt® motor coupling is designed for large motor shaft diameters and features a bellows coupling to compensate for thermal expansion of the motor shaft—ensuring long motor life by preventing thrust load on the motor bearings.

"PHA" Series ServoFit® Precision Planetary Gearhead



Part No. Explanation

PHA 5 2 1 F 0050 MF L

	Series	Size	Generation	No. of Gear Stages	Housing	Ratio Option	Input Option	Input Option
Series	PHA							
Size		5						
Generation			2					
No. of Gear Stages				1				
Housing Style					F			
Ratio						0050		
Motor Adapter							MF	

Series **PHA (V)** Advanced Planetary Gearhead
3 Stage for 9 or 10 ONLY

Size **5** 3, 4, **5**, 7, 8, 9, 10

Generation **2** First generation 1, second generation **2**, etc.

No. of Gear Stages **1** 1, 2, (determined by the ratio)

Housing Style **F** Output Flange

Ratio **0050** Approximate: 0050 = 5.00:1 (range of 4:1 up to 100:1)

Motor Adapter **MF** FlexiAdapt® Motor Adapter (Motor information must be specified.)

Option **L** Large Input Option (available in sizes PHA3 thru PHA9)

C—ServoCool (available in sizes PHA4 thru PHA10)

Available with rack and pinion as **ZTRS**. Contact STOBER Drives.



If a "PHA" gearhead is to be mounted from the "B²" side, **SPECIFY WHEN ORDERING**. For proper mounting the paint must be eliminated and the tolerance held on that surface. Side "B²" mounting is not possible with the Large Input.

Motor Mounting Specifications

STOBER ServoFit Gearheads will fit the motor of your choice by assembling the correct motor mounting plate between the motor and the gearhead. **When ordering a gearhead, specify the motor manufacturer and part number, provide the motor drawing with dimensions, or specify the motor mounting dimensions.** The motor plate thickness (L⁹) dimension will be determined by the motor shaft length. The minimum motor plate thickness is shown below. For a precise dimension on a specific motor, contact STOBER Technical Support.

The following dimensions are required to provide the correct motor mounting plate:

1. D⁶ Motor Shaft Diameter (If an adapter bushing is required it will be supplied with the motor plate.)
2. D⁷ Pilot Diameter
3. D⁸ Bolt Circle Diameter
4. D⁹ Bolt Diameter
5. L¹¹ Motor Shaft Length
6. L¹² Pilot Length
7. L¹⁴ Square Flange (Optional — Motor plate will typically be made to match.)

Table No. 1

Motor Plate Dims.	Planetary Size					
	PHA322	PHA321 PHA422	PHA421 PHA422L PHA522	PHA421L PHA521 PHA522L PHA722	PHA521L PHA721 PHA722L PHA822 PHA933	PHA821 PHA932 PHA1032 PHA1033
D ⁶ Max.	14	19	24	32	38	48
L ⁹ Min.	15	18	21	24	25	33

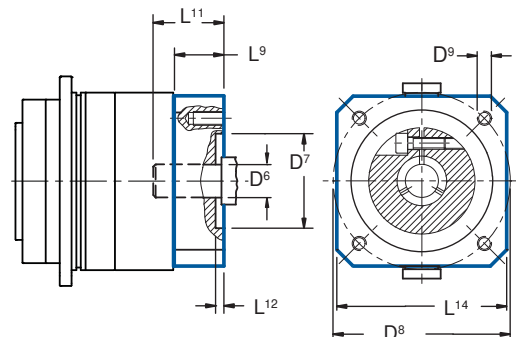



"PHA" Series ServoFit® Precision Planetary Gearhead Shaft Loads

All formulas shown are based on METRIC values.

Upper case letters are permissible values. Lower case letters are for existing values.

The permissible load and tilting moment values are based on an output speed of 100 RPM. For higher speeds the following applies, where n_2 is the desired speed:

$$F_{2AX} = \frac{F_{2A}}{\sqrt[3]{\frac{n_2}{100}}} \quad M_{2KX} = \frac{M_{2K}}{\sqrt[3]{\frac{n_2}{100}}}$$

The application input tilting moment should be determined by the following formula:

$$M_{2A} = \frac{F_{2a} \cdot y_2 + F_{2rb} \cdot (X_2 + Z_2)}{1000} \leq M_{2KB}$$

$$M_{2Ka} = \sqrt[3]{\frac{\Omega_{2b1} \cdot t_{b1} \cdot M_{2kb1}^3 + \dots + \Omega_{2bn} \cdot t_{bn} \cdot M_{2kbn}^3}{\Omega_{2b1} \cdot t_{b1} + \dots + \Omega_{2bn} \cdot t_{bn}}} \leq M_{2K}$$

$$F_{2r} = \sqrt[3]{\frac{\Omega_{2b1} \cdot t_{b1} \cdot F_{2rb1}^3 + \dots + \Omega_{2bn} \cdot t_{bn} \cdot F_{2rbn}^3}{\Omega_{2b1} \cdot t_{b1} + \dots + \Omega_{2bn} \cdot t_{bn}}} \leq F_{2R}$$

- where:
- F_{2a} Axial Load at Output Shaft
 - F_{2A} Permissible Axial Load
 - F_{2r} Radial Load at Output Shaft
 - F_{2R} Permissible Radial Load
 - F_{2RB} Acceleration Permissible Radial Load
 - M_{2K} Rated Tilting Torque
 - M_{2k} Equivalent Tilting Load
 - M_{2KB} Acceleration Tilting Torque
 - Z_2 Distance Factor

The hours of life (L_h) of the unit can be determined by the following formula:

bearing life for duty cycle $\leq 40\%$

- $L_h > 10,000$ hours if $M_{2k}/M_{2A} < 1.25$ and > 1
- $L_h > 20,000$ hours if $M_{2k}/M_{2A} > 1.25$ and > 1.5
- $L_h > 30,000$ hours if $M_{2k}/M_{2A} < 1.5$

bearing life for duty cycle $\geq 40\%$

$$L_{hA} = L_h \left(\frac{40\%}{\text{Duty Cycle}} \right)$$

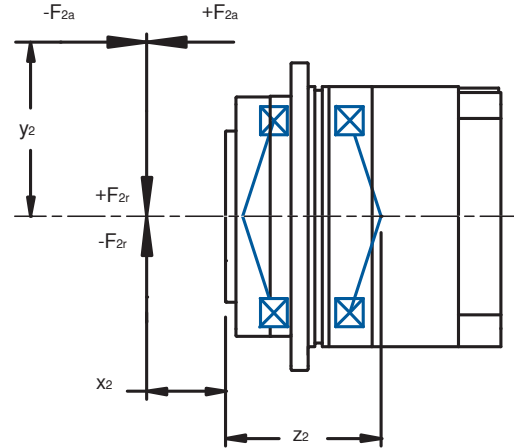

Table No. 2 Permissible Output Load and Tilting Moments

Unit No.	Z_2		F_{2AMAX}		F_{2R}		F_{2RB}		M_{2K}		M_{2KB}		C_{2K}	
	mm	inches	N	lbs.	N	lbs.	N	lbs.	Nm	in.lbs.	Nm	in.lbs.	Nm/arcmin	In.lbs/arcmin
PHA3	62	2.44	1,650	371	1,613	363	1,613	363	100	885	100	885	53	469
PHA4	84	3.31	2,150	484	3,095	696	3,571	803	260	2,124	300	2,655	160	1,416
PHA5	97	3.82	4,150	934	4,536	1,021	4,897	1,102	440	3,717	475	4,204	380	3,363
PHA7	88	3.46	6,150	1,384	17,045	3,835	17,045	3,835	1,500	13,275	1,500	13,275	500	4,425
PHA8	126	4.96	10,050	2,261	27,778	6,250	27,778	6,250	3,500	30,975	3,500	30,975	1,550	13,718
PHA(V)9	155	6.10	33,000	7,425	48,387	10,887	70,968	15,938	7,500	66,375	11,000	97,350	7,500	66,375
PHA(V)10	171	6.73	50,000	11,250	51,462	11,579	73,099	16,447	8,800	77,880	12,500	110,625	9,500	84,075

During EMERGENCY OFF operation (maximum stops per gearhead = 1000) the permissible values in the table for F_{2A} , F_{2R} , and M_{2K} can be multiplied by a factor of 2.

Permissible Motor Tilting Torque

The permissible tilting torque of the motor attached to the gear unit is a result of the static and dynamic load "F" from the motor weight, mass acceleration, and vibration multiplied by the distance from the center of gravity "ls" of the motor.

$$M_{1K} = F \times l_s \leq M_{1K}$$

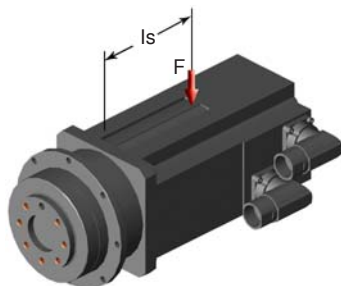

Table No. 3 M_{1K}

Unit Type with MT	Nm	in.lbs.
PHA422	20	177
PHA421, PHA522	40	354
PHA521, PHA722	80	708
PHA721, PHA822, PHVA933	200	1,770
PHA821, PHA932, PHA1032, PHVA1033	400	3,540



"PHA" Series – Advanced ServoFit® Precision Planetary Gearhead Selection Data



P
H
A

Part Number (Gearhead + Input)	Exact Ratio i	Maximum Input Speed		Motor Shaft øD ⁶ mm	Input ¹⁾ Inertia J ₁ kgcm ²	Torsional Stiffness per arcmin C ₂		Output Torque					
		Continuous RPM (n ₁)	Cyclic RPM (n ₁)			in.lbs.	Nm	Nominal ²⁾ M _{2N}		Acceleration M _{2B}		Peak ³⁾ M _{2PEAK}	
								in.lbs.	Nm	in.lbs.	Nm	in.lbs.	Nm

PHA321 with Motor Mounting Plate

PHA321F0050 MF	5.000	3,000	6,000	≤11	0.55	101.0	11.4	399	45	576	65	1,152	130
PHA321F0050 MF	5.000	3,000	6,000	>11≤14	0.56	103.2	11.7	399	45	576	65	1,152	130
PHA321F0050 MF	5.000	3,000	6,000	>14≤19	0.56	103.2	11.7	399	45	576	65	1,152	130
PHA321F0050 MFL	5.000	3,000	6,000	>19≤24	1.64	111.0	12.5	399	45	576	65	1,152	130
PHA321F0070 MF	7.000	3,500	6,000	≤11	0.52	95.8	10.8	399	45	531	60	1,152	130
PHA321F0070 MF	7.000	3,500	6,000	>11≤14	0.52	95.8	10.8	399	45	531	60	1,152	130
PHA321F0070 MF	7.000	3,500	6,000	>14≤19	0.52	95.8	10.8	399	45	531	60	1,152	130
PHA321F0070 MFL	7.000	3,500	6,000	>19≤24	1.58	99.7	11.3	399	45	531	60	1,152	130
PHA321F0100 MF	10.00	3,800	6,000	≤11	0.50	77.8	8.8	266	30	443	50	886	100
PHA321F0100 MF	10.00	3,800	6,000	>11≤14	0.50	77.8	8.8	266	30	443	50	886	100
PHA321F0100 MF	10.00	3,800	6,000	>14≤19	0.50	77.8	8.8	266	30	443	50	886	100
PHA321F0100 MFL	10.00	3,800	6,000	>19≤24	1.56	79.1	8.9	266	30	443	50	886	100

PHA322 with Motor Mounting Plate

PHA322F0200 MF	20.00	4,500	8,000	≤9	0.11	89.3	10.1	399	45	576	65	1,152	130
PHA322F0200 MF	20.00	4,500	8,000	>11≤14	0.14	89.7	10.1	399	45	576	65	1,152	130
PHA322F0200 MF	20.00	4,500	8,000	>9≤11	0.12	89.7	10.1	399	45	576	65	1,152	130
PHA322F0250 MF	25.00	4,500	8,000	≤9	0.09	89.7	10.1	399	45	576	65	1,152	130
PHA322F0250 MF	25.00	4,500	8,000	>11≤14	0.12	89.9	10.2	399	45	576	65	1,152	130
PHA322F0250 MF	25.00	4,500	8,000	>9≤11	0.10	89.9	10.2	399	45	576	65	1,152	130
PHA322F0280 MF	28.00	4,500	8,000	≤9	0.10	90.1	10.2	399	45	531	60	1,152	130
PHA322F0280 MF	28.00	4,500	8,000	>11≤14	0.14	90.3	10.2	399	45	531	60	1,152	130
PHA322F0280 MF	28.00	4,500	8,000	>9≤11	0.12	90.3	10.2	399	45	531	60	1,152	130
PHA322F0350 MF	35.00	4,500	8,000	≤9	0.08	89.0	10.0	399	45	576	65	1,152	130
PHA322F0350 MF	35.00	4,500	8,000	>11≤14	0.11	89.0	10.0	399	45	576	65	1,152	130
PHA322F0350 MF	35.00	4,500	8,000	>9≤11	0.09	89.0	10.0	399	45	576	65	1,152	130
PHA322F0400 MF	40.00	4,500	8,000	≤9	0.10	75.9	8.6	266	30	443	50	886	100
PHA322F0400 MF	40.00	4,500	8,000	>11≤14	0.14	76.0	8.6	266	30	443	50	886	100
PHA322F0400 MF	40.00	4,500	8,000	>9≤11	0.11	76.0	8.6	266	30	443	50	886	100
PHA322F0500 MF	50.00	4,500	8,000	≤9	0.07	86.7	9.8	399	45	576	65	1,152	130
PHA322F0500 MF	50.00	4,500	8,000	>11≤14	0.10	86.7	9.8	399	45	576	65	1,152	130
PHA322F0500 MF	50.00	4,500	8,000	>9≤11	0.08	86.7	9.8	399	45	576	65	1,152	130
PHA322F0700 MF	70.00	4,500	8,000	≤9	0.07	88.7	10.0	399	45	531	60	1,152	130
PHA322F0700 MF	70.00	4,500	8,000	>11≤14	0.10	88.7	10.0	399	45	531	60	1,152	130
PHA322F0700 MF	70.00	4,500	8,000	>9≤11	0.08	88.7	10.0	399	45	531	60	1,152	130
PHA322F1000 MF	100.0	4,500	8,000	≤9	0.07	75.4	8.5	266	30	443	50	886	100
PHA322F1000 MF	100.0	4,500	8,000	>11≤14	0.10	75.4	8.5	266	30	443	50	886	100
PHA322F1000 MF	100.0	4,500	8,000	>9≤11	0.08	75.4	8.5	266	30	443	50	886	100

PHA421 with Motor Mounting Plate Continued Next Page

PHA421F0040 MF	4.000	2,300	5,000	≤14	2.13	282.8	31.9	753	85	1,152	130	1,701	192
PHA421F0040 MF	4.000	2,300	5,000	>14≤19	2.15	294.2	33.2	753	85	1,152	130	2,126	240
PHA421F0040 MF	4.000	2,300	5,000	>19≤24	2.05	294.2	33.2	753	85	1,152	130	2,126	240
PHA421F0040 MFC	4.000	3,300	5,000	≤14	2.46	282.8	31.9	753	85	1,152	130	1,701	192
PHA421F0040 MFC	4.000	3,300	5,000	>14≤19	2.31	294.2	33.2	753	85	1,152	130	2,126	240
PHA421F0040 MFC	4.000	3,300	5,000	>19≤24	2.20	294.2	33.2	753	85	1,152	130	2,126	240
PHA421F0040 MFL	4.000	2,300	5,000	>24≤32	5.26	311.0	35.1	753	85	1,152	130	2,126	240
PHA421F0040 MFLC	4.000	3,300	5,000	>24≤32	5.69	311.0	35.1	753	85	1,152	130	2,126	240
PHA421F0050 MF	5.000	2,700	6,000	≤14	1.95	288.9	32.6	753	85	1,152	130	2,126	240
PHA421F0050 MF	5.000	2,700	6,000	>14≤19	1.97	296.4	33.5	753	85	1,152	130	2,126	240
PHA421F0050 MF	5.000	2,700	6,000	>19≤24	1.87	296.4	33.5	753	85	1,152	130	2,126	240
PHA421F0050 MFC	5.000	3,700	6,000	≤14	2.28	288.9	32.6	753	85	1,152	130	2,126	240

¹⁾ Inertia based on maximum input. For lower inertia using smaller diameter input, contact STOBER.

²⁾ Based on input speed: n₁ = 2000 RPM

For torque at higher input speeds (M_{2NX}) solve the formula, where n₁ = Actual Input Speed.
$$M_{2NX} = \frac{M_{2N}}{\sqrt[3]{\frac{n_1}{2000}}}$$

³⁾ Maximum momentary torque for emergency stops or heavy shock load. Admissible stops per life of gearhead = 1,000 stops maximum.



"PHA" Series – Advanced ServoFit® Precision Planetary Gearhead Selection Data



Part Number (Gearhead + Input)	Exact Ratio i	Maximum Input Speed		Motor Shaft ØD ⁶ mm	Input ¹⁾ Inertia J ₁ kgcm ²	Torsional Stiffness per arcmin		Output Torque					
		Continuous RPM (n _i)	Cyclic RPM (n _i)			C ₂	Nominal ²⁾		Acceleration		Peak ³⁾		
							M _{2N}	M _{2B}	M _{2PEAK}	M _{2PEAK}			
Gearhead					in.lbs.	Nm	in.lbs.	Nm	in.lbs.	Nm	in.lbs.	Nm	

PHA421 with Motor Mounting Plate *Continued*

PHA421F0050 MFC	5.000	3,700	6,000	>14≤19	2.13	296.4	33.5	753	85	1,152	130	2,126	240
PHA421F0050 MFC	5.000	3,700	6,000	>19≤24	2.02	296.4	33.5	753	85	1,152	130	2,126	240
PHA421F0050 MFL	5.000	2,700	6,000	>24≤32	5.08	307.1	34.7	753	85	1,152	130	2,126	240
PHA421F0050 MFLC	5.000	3,700	6,000	>24≤32	5.51	307.1	34.7	753	85	1,152	130	2,126	240
PHA421F0070 MF	7.000	3,200	6,000	≤14	1.79	259.7	29.3	753	85	974	110	2,126	240
PHA421F0070 MF	7.000	3,200	6,000	>14≤19	1.79	259.7	29.3	753	85	974	110	2,126	240
PHA421F0070 MF	7.000	3,200	6,000	>19≤24	1.69	259.7	29.3	753	85	974	110	2,126	240
PHA421F0070 MFC	7.000	4,200	6,000	≤14	2.13	259.7	29.3	753	85	974	110	2,126	240
PHA421F0070 MFC	7.000	4,200	6,000	>14≤19	1.98	262.7	29.7	753	85	974	110	2,126	240
PHA421F0070 MFC	7.000	4,200	6,000	>19≤24	1.85	259.7	29.3	753	85	974	110	2,126	240
PHA421F0070 MFL	7.000	3,200	6,000	>24≤32	4.85	265.3	29.9	753	85	974	110	2,126	240
PHA421F0070 MFLC	7.000	4,200	6,000	>24≤32	5.29	265.3	29.9	753	85	974	110	2,126	240
PHA421F0100 MF	10.00	3,500	6,000	≤14	1.72	182.5	20.6	531	60	886	100	1,772	200
PHA421F0100 MF	10.00	3,500	6,000	>14≤19	1.72	182.5	20.6	531	60	886	100	1,772	200
PHA421F0100 MF	10.00	3,500	6,000	>19≤24	1.62	182.5	20.6	531	60	886	100	1,772	200
PHA421F0100 MFC	10.00	4,500	6,000	≤14	2.05	182.5	20.6	531	60	886	100	1,772	200
PHA421F0100 MFC	10.00	4,500	6,000	>14≤19	1.90	183.3	20.7	531	60	886	100	1,772	200
PHA421F0100 MFC	10.00	4,500	6,000	>19≤24	1.77	182.5	20.6	531	60	886	100	1,772	200
PHA421F0100 MFL	10.00	3,500	6,000	>24≤32	4.78	183.9	20.8	531	60	886	100	1,772	200
PHA421F0100 MFLC	10.00	4,500	6,000	>24≤32	5.21	183.9	20.8	531	60	886	100	1,772	200

PHA422 with Motor Mounting Plate *Continued Next Page*

PHA422F0160 MF	16.00	3,700	6,500	≤11	0.63	230.1	26.0	797	90	1,152	130	2,126	240
PHA422F0160 MF	16.00	3,700	6,500	>11≤14	0.64	231.3	26.1	797	90	1,152	130	2,126	240
PHA422F0160 MF	16.00	3,700	6,500	>14≤19	0.64	231.3	26.1	797	90	1,152	130	2,126	240
PHA422F0160 MFL	16.00	3,700	6,500	>19≤24	1.72	234.9	26.5	797	90	1,152	130	2,126	240
PHA422F0160 MFLC	16.00	4,500	6,500	>19≤24	1.87	234.4	26.5	797	90	1,152	130	2,126	240
PHA422F0200 MF	20.00	3,700	6,500	≤11	0.62	251.3	28.4	797	90	1,152	130	2,126	240
PHA422F0200 MF	20.00	3,700	6,500	>11≤14	0.63	252.2	28.5	797	90	1,152	130	2,126	240
PHA422F0200 MF	20.00	3,700	6,500	>14≤19	0.63	252.2	28.5	797	90	1,152	130	2,126	240
PHA422F0200 MFL	20.00	3,700	6,500	>19≤24	1.70	254.9	28.8	797	90	1,152	130	2,126	240
PHA422F0200 MFLC	20.00	4,500	6,500	>19≤24	1.86	254.5	28.7	797	90	1,152	130	2,126	240
PHA422F0250 MF	25.00	4,000	7,000	≤11	0.57	250.9	28.3	797	90	1,152	130	2,126	240
PHA422F0250 MF	25.00	4,000	7,000	>11≤14	0.58	251.5	28.4	797	90	1,152	130	2,126	240
PHA422F0250 MF	25.00	4,000	7,000	>14≤19	0.58	251.5	28.4	797	90	1,152	130	2,126	240
PHA422F0250 MFL	25.00	4,000	7,000	>19≤24	1.65	253.2	28.6	797	90	1,152	130	2,126	240
PHA422F0250 MFLC	25.00	4,800	7,000	>19≤24	1.81	253.0	28.6	797	90	1,152	130	2,126	240
PHA422F0280 MF	28.00	4,500	8,000	≤11	0.53	220.4	24.9	797	90	1,152	130	2,126	240
PHA422F0280 MF	28.00	4,500	8,000	>11≤14	0.53	220.4	24.9	797	90	1,152	130	2,126	240
PHA422F0280 MF	28.00	4,500	8,000	>14≤19	0.53	220.4	24.9	797	90	1,152	130	2,126	240
PHA422F0280 MFL	28.00	4,500	8,000	>19≤24	1.59	221.7	25.0	797	90	1,152	130	2,126	240
PHA422F0280 MFLC	28.00	5,300	8,000	>19≤24	1.74	221.7	25.0	797	90	1,152	130	2,126	240
PHA422F0350 MF	35.00	4,500	8,000	≤11	0.52	243.8	27.5	797	90	1,152	130	2,126	240
PHA422F0350 MF	35.00	4,500	8,000	>11≤14	0.52	243.8	27.5	797	90	1,152	130	2,126	240
PHA422F0350 MF	35.00	4,500	8,000	>14≤19	0.52	243.8	27.5	797	90	1,152	130	2,126	240
PHA422F0350 MFL	35.00	4,500	8,000	>19≤24	1.58	244.7	27.6	797	90	1,152	130	2,126	240
PHA422F0350 MFLC	35.00	5,300	8,000	>19≤24	1.74	244.7	27.6	797	90	1,152	130	2,126	240
PHA422F0400 MF	40.00	4,500	8,000	≤11	0.50	213.8	24.1	797	90	1,152	130	2,126	240
PHA422F0400 MF	40.00	4,500	8,000	>11≤14	0.50	213.8	24.1	797	90	1,152	130	2,126	240
PHA422F0400 MF	40.00	4,500	8,000	>14≤19	0.50	213.8	24.1	797	90	1,152	130	2,126	240
PHA422F0400 MFL	40.00	4,500	8,000	>19≤24	1.56	214.4	24.2	797	90	1,152	130	2,126	240
PHA422F0400 MFLC	40.00	5,300	8,000	>19≤24	1.72	214.4	24.2	797	90	1,152	130	2,126	240

Index of Symbols: MF — Motor adapter with FlexiAdapt® coupling; L — Large Input; C — ServoCool

See Page 86 for Options and Part Number Configuration.



"PHA" Series – Advanced ServoFit® Precision Planetary Gearhead Selection Data



P
H
A

Part Number (Gearhead + Input)	Exact Ratio i	Maximum Input Speed		Motor Shaft ØD ⁶ mm	Input ¹⁾ Inertia J ₁ kgcm ²	Torsional Stiffness per arcmin C ₂		Output Torque					
		Continuous RPM (n ₁)	Cyclic RPM (n ₁)			in.lbs.	Nm	Nominal ²⁾ M _{2N}		Acceleration M _{2B}		Peak ³⁾ M _{2PEAK}	
								in.lbs.	Nm	in.lbs.	Nm	in.lbs.	Nm
PHA422 with Motor Mounting Plate <i>Continued</i>													
PHA422F0500 MF	50.00	4,500	8,000	≤11	0.50	238.5	26.9	797	90	1,152	130	2,126	240
PHA422F0500 MF	50.00	4,500	8,000	>11≤14	0.50	238.5	26.9	797	90	1,152	130	2,126	240
PHA422F0500 MF	50.00	4,500	8,000	>14≤19	0.50	238.5	26.9	797	90	1,152	130	2,126	240
PHA422F0500 MFL	50.00	4,500	8,000	>19≤24	1.56	239.0	27.0	797	90	1,152	130	2,126	240
PHA422F0500 MFLC	50.00	5,300	8,000	>19≤24	1.71	239.0	27.0	797	90	1,152	130	2,126	240
PHA422F0700 MF	70.00	4,500	8,000	≤11	0.50	236.8	26.7	797	90	974	110	2,126	240
PHA422F0700 MF	70.00	4,500	8,000	>11≤14	0.50	236.8	26.7	797	90	974	110	2,126	240
PHA422F0700 MF	70.00	4,500	8,000	>14≤19	0.50	236.8	26.7	797	90	974	110	2,126	240
PHA422F0700 MFL	70.00	4,500	8,000	>19≤24	1.56	237.0	26.8	797	90	974	110	2,126	240
PHA422F0700 MFLC	70.00	5,300	8,000	>19≤24	1.71	237.0	26.8	797	90	974	110	2,126	240
PHA422F1000 MF	100.0	4,500	8,000	≤11	0.50	176.6	19.9	531	60	886	100	1,772	200
PHA422F1000 MF	100.0	4,500	8,000	>11≤14	0.50	176.6	19.9	531	60	886	100	1,772	200
PHA422F1000 MF	100.0	4,500	8,000	>14≤19	0.50	176.6	19.9	531	60	886	100	1,772	200
PHA422F1000 MFL	100.0	4,500	8,000	>19≤24	1.56	176.7	19.9	531	60	886	100	1,772	200
PHA422F1000 MFLC	100.0	5,300	8,000	>19≤24	1.71	176.7	19.9	531	60	886	100	1,772	200

PHA521 with Motor Mounting Plate													
PHA521F0040 MF	4.000	2,200	5,000	≤19	4.96	647.7	73.1	1,860	210	2,835	320	4,422	499
PHA521F0040 MF	4.000	2,200	5,000	>19≤24	5.03	679.0	76.7	1,860	210	2,835	320	4,915	555
PHA521F0040 MF	4.000	2,200	5,000	>24≤32	4.93	679.0	76.7	1,860	210	2,835	320	4,915	555
PHA521F0040 MF	4.000	2,200	5,000	>32≤35	4.93	679.0	76.7	1,860	210	2,835	320	4,915	555
PHA521F0040 MFC	4.000	3,200	5,000	≤19	5.87	647.7	73.1	1,860	210	2,447	276	3,059	345
PHA521F0040 MFC	4.000	3,200	5,000	>19≤24	5.48	679.0	76.7	1,860	210	2,835	320	4,915	555
PHA521F0040 MFC	4.000	3,200	5,000	>24≤32	5.36	679.0	76.7	1,860	210	2,835	320	4,915	555
PHA521F0040 MFL	4.000	2,200	5,000	>32≤38	12.12	752.8	85.0	1,860	210	2,835	320	4,915	555
PHA521F0040 MFLC	4.000	3,200	5,000	>32≤38	14.91	752.8	85.0	1,860	210	2,835	320	4,915	555
PHA521F0050 MF	5.000	2,500	5,500	≤19	5.78	682.7	77.1	1,860	210	2,835	320	5,315	600
PHA521F0050 MF	5.000	2,500	5,500	>19≤24	5.85	704.6	79.5	1,860	210	2,835	320	5,315	600
PHA521F0050 MF	5.000	2,500	5,500	>24≤32	5.75	704.6	79.5	1,860	210	2,835	320	5,315	600
PHA521F0050 MF	5.000	2,500	5,500	>32≤35	5.75	704.6	79.5	1,860	210	2,835	320	5,315	600
PHA521F0050 MFC	5.000	3,500	5,500	≤19	6.69	682.7	77.1	1,860	210	2,835	320	3,824	432
PHA521F0050 MFC	5.000	3,500	5,500	>19≤24	6.30	704.6	79.5	1,860	210	2,835	320	5,315	600
PHA521F0050 MFC	5.000	3,500	5,500	>24≤32	6.18	704.6	79.5	1,860	210	2,835	320	5,315	600
PHA521F0050 MFL	5.000	2,500	5,500	>32≤38	12.94	753.7	85.1	1,860	210	2,835	320	5,315	600
PHA521F0050 MFLC	5.000	3,500	5,500	>32≤38	15.73	753.7	85.1	1,860	210	2,835	320	5,315	600
PHA521F0070 MF	7.000	3,000	6,000	≤19	5.30	627.3	70.8	1,860	210	2,392	270	5,315	600
PHA521F0070 MF	7.000	3,000	6,000	>19≤24	5.30	627.3	70.8	1,860	210	2,392	270	5,315	600
PHA521F0070 MF	7.000	3,000	6,000	>24≤32	5.20	627.3	70.8	1,860	210	2,392	270	5,315	600
PHA521F0070 MF	7.000	3,000	6,000	>32≤35	5.20	627.3	70.8	1,860	210	2,392	270	5,315	600
PHA521F0070 MFC	7.000	4,000	6,000	≤19	6.21	627.3	70.8	1,860	210	2,392	270	5,315	600
PHA521F0070 MFC	7.000	4,000	6,000	>19≤24	5.75	627.3	70.8	1,860	210	2,392	270	5,315	600
PHA521F0070 MFC	7.000	4,000	6,000	>24≤32	5.63	627.3	70.8	1,860	210	2,392	270	5,315	600
PHA521F0070 MFL	7.000	3,000	6,000	>32≤38	12.13	650.1	73.4	1,860	210	2,392	270	5,315	600
PHA521F0070 MFLC	7.000	4,000	6,000	>32≤38	14.92	650.1	73.4	1,860	210	2,392	270	5,315	600
PHA521F0100 MF	10.00	3,300	6,000	≤19	5.05	472.7	53.4	1,240	140	2,215	250	4,429	500
PHA521F0100 MF	10.00	3,300	6,000	>19≤24	5.05	472.7	53.4	1,240	140	2,215	250	4,429	500
PHA521F0100 MF	10.00	3,300	6,000	>24≤32	4.95	472.7	53.4	1,240	140	2,215	250	4,429	500
PHA521F0100 MF	10.00	3,300	6,000	>32≤35	4.95	472.7	53.4	1,240	140	2,215	250	4,429	500
PHA521F0100 MFC	10.00	4,500	6,000	≤19	5.96	472.7	53.4	1,240	140	2,215	250	4,429	500
PHA521F0100 MFC	10.00	4,500	6,000	>19≤24	5.50	472.7	53.4	1,240	140	2,215	250	4,429	500
PHA521F0100 MFC	10.00	4,500	6,000	>24≤32	5.38	472.7	53.4	1,240	140	2,215	250	4,429	500
PHA521F0100 MFL	10.00	3,300	6,000	>32≤38	11.88	479.0	54.1	1,240	140	2,215	250	4,429	500
PHA521F0100 MFLC	10.00	4,500	6,000	>32≤38	14.67	479.0	54.1	1,240	140	2,215	250	4,429	500

¹⁾ Inertia based on maximum input. For lower inertia using smaller diameter input, contact STOBER.

²⁾ Based on input speed: n₁ = 2000 RPM

For torque at higher input speeds (M_{2Nx}) solve the formula, where n₁ = Actual Input Speed.
$$M_{2Nx} = \frac{M_{2N}}{\sqrt[3]{\frac{n_1}{2000}}}$$

³⁾ Maximum momentary torque for emergency stops or heavy shock load. Admissible stops per life of gearhead = 1,000 stops maximum.



"PHA" Series – Advanced ServoFit® Precision Planetary Gearhead Selection Data



Part Number (Gearhead + Input)	Exact Ratio i	Maximum Input Speed		Motor Shaft ØD ⁶ mm	Input ¹⁾ Inertia J ₁ kgcm ²	Torsional Stiffness per arcmin		Output Torque					
		Continuous RPM (n _i)	Cyclic RPM (n _c)			C ₂	Nominal ²⁾		Acceleration		Peak ³⁾		
							M _{2N}	M _{2B}	M _{2PEAK}	M _{2PEAK}			
Gearhead					in.lbs.	Nm	in.lbs.	Nm	in.lbs.	Nm	in.lbs.	Nm	

PHA522 with Motor Mounting Plate *Continued Next Page*

PHA522F0160 MF	16.00	3,300	6,000	≤14	1.93	561.8	63.4	1,860	210	2,835	320	4,915	555
PHA522F0160 MF	16.00	3,300	6,000	>14≤19	1.95	564.5	63.7	1,860	210	2,835	320	4,915	555
PHA522F0160 MF	16.00	3,300	6,000	>19≤24	1.85	564.5	63.7	1,860	210	2,835	320	4,915	555
PHA522F0160 MFC	16.00	4,300	6,000	≤14	2.26	561.8	63.4	1,860	210	2,835	320	4,915	555
PHA522F0160 MFC	16.00	4,300	6,000	>14≤19	2.11	564.5	63.7	1,860	210	2,835	320	4,915	555
PHA522F0160 MFC	16.00	4,300	6,000	>19≤24	2.00	564.5	63.7	1,860	210	2,835	320	4,915	555
PHA522F0160 MFL	16.00	3,300	6,000	>24≤32	5.06	568.2	64.1	1,860	210	2,835	320	4,915	555
PHA522F0160 MFLC	16.00	4,300	6,000	>24≤32	5.49	568.2	64.1	1,860	210	2,835	320	4,915	555
PHA522F0200 MF	20.00	3,300	6,000	≤14	1.98	618.9	69.9	1,949	220	2,835	320	5,315	600
PHA522F0200 MF	20.00	3,300	6,000	>14≤19	2.00	621.0	70.1	1,949	220	2,835	320	5,315	600
PHA522F0200 MF	20.00	3,300	6,000	>19≤24	1.90	621.0	70.1	1,949	220	2,835	320	5,315	600
PHA522F0200 MFC	20.00	4,300	6,000	≤14	2.31	618.9	69.9	1,949	220	2,835	320	5,315	600
PHA522F0200 MFC	20.00	4,300	6,000	>14≤19	2.16	621.0	70.1	1,949	220	2,835	320	5,315	600
PHA522F0200 MFC	20.00	4,300	6,000	>19≤24	2.06	621.0	70.1	1,949	220	2,835	320	5,315	600
PHA522F0200 MFL	20.00	3,300	6,000	>24≤32	5.11	623.8	70.4	1,949	220	2,835	320	5,315	600
PHA522F0200 MFLC	20.00	4,300	6,000	>24≤32	5.54	623.8	70.4	1,949	220	2,835	320	5,315	600
PHA522F0250 MF	25.00	3,700	6,500	≤14	1.86	618.7	69.8	1,949	220	2,835	320	5,315	600
PHA522F0250 MF	25.00	3,700	6,500	>14≤19	1.88	620.1	70.0	1,949	220	2,835	320	5,315	600
PHA522F0250 MF	25.00	3,700	6,500	>19≤24	1.78	620.1	70.0	1,949	220	2,835	320	5,315	600
PHA522F0250 MFC	25.00	4,500	6,500	≤14	2.19	618.7	69.8	1,949	220	2,835	320	5,315	600
PHA522F0250 MFC	25.00	4,500	6,500	>14≤19	2.04	620.1	70.0	1,949	220	2,835	320	5,315	600
PHA522F0250 MFC	25.00	4,500	6,500	>19≤24	1.94	620.1	70.0	1,949	220	2,835	320	5,315	600
PHA522F0250 MFL	25.00	3,700	6,500	>24≤32	4.99	621.9	70.2	1,949	220	2,835	320	5,315	600
PHA522F0250 MFLC	25.00	4,500	6,500	>24≤32	5.42	621.9	70.2	1,949	220	2,835	320	5,315	600
PHA522F0280 MF	28.00	4,000	7,000	≤14	1.73	536.6	60.6	1,860	210	2,835	320	4,915	555
PHA522F0280 MF	28.00	4,000	7,000	>14≤19	1.73	536.6	60.6	1,860	210	2,835	320	4,915	555
PHA522F0280 MF	28.00	4,000	7,000	>19≤24	1.63	536.6	60.6	1,860	210	2,835	320	4,915	555
PHA522F0280 MFC	28.00	5,000	7,000	≤14	2.06	536.6	60.6	1,860	210	2,835	320	4,915	555
PHA522F0280 MFC	28.00	5,000	7,000	>14≤19	1.89	537.4	60.7	1,860	210	2,835	320	4,915	555
PHA522F0280 MFC	28.00	5,000	7,000	>19≤24	1.78	536.6	60.6	1,860	210	2,835	320	4,915	555
PHA522F0280 MFL	28.00	4,000	7,000	>24≤32	4.79	538.1	60.7	1,860	210	2,835	320	4,915	555
PHA522F0280 MFLC	28.00	5,000	7,000	>24≤32	5.22	538.1	60.7	1,860	210	2,835	320	4,915	555
PHA522F0350 MF	35.00	4,000	7,000	≤14	1.75	599.0	67.6	1,949	220	2,835	320	5,315	600
PHA522F0350 MF	35.00	4,000	7,000	>14≤19	1.75	599.0	67.6	1,949	220	2,835	320	5,315	600
PHA522F0350 MF	35.00	4,000	7,000	>19≤24	1.65	599.0	67.6	1,949	220	2,835	320	5,315	600
PHA522F0350 MFC	35.00	5,000	7,000	≤14	2.08	599.0	67.6	1,949	220	2,835	320	5,315	600
PHA522F0350 MFC	35.00	5,000	7,000	>14≤19	1.90	599.7	67.7	1,949	220	2,835	320	5,315	600
PHA522F0350 MFC	35.00	5,000	7,000	>19≤24	1.80	599.0	67.6	1,949	220	2,835	320	5,315	600
PHA522F0350 MFL	35.00	4,000	7,000	>24≤32	4.81	600.2	67.8	1,949	220	2,835	320	5,315	600
PHA522F0350 MFLC	35.00	5,000	7,000	>24≤32	5.24	600.2	67.8	1,949	220	2,835	320	5,315	600
PHA522F0400 MF	40.00	4,000	7,000	≤14	1.69	514.8	58.1	1,860	210	2,835	320	4,915	555
PHA522F0400 MF	40.00	4,000	7,000	>14≤19	1.69	514.8	58.1	1,860	210	2,835	320	4,915	555
PHA522F0400 MF	40.00	4,000	7,000	>19≤24	1.59	514.8	58.1	1,860	210	2,835	320	4,915	555
PHA522F0400 MFC	40.00	5,000	7,000	≤14	2.02	514.8	58.1	1,860	210	2,835	320	4,915	555
PHA522F0400 MFC	40.00	5,000	7,000	>14≤19	1.84	515.2	58.2	1,860	210	2,835	320	4,915	555
PHA522F0400 MFC	40.00	5,000	7,000	>19≤24	1.74	514.8	58.1	1,860	210	2,835	320	4,915	555
PHA522F0400 MFL	40.00	4,000	7,000	>24≤32	4.75	515.5	58.2	1,860	210	2,835	320	4,915	555
PHA522F0400 MFLC	40.00	5,000	7,000	>24≤32	5.18	515.5	58.2	1,860	210	2,835	320	4,915	555

Index of Symbols: MF — Motor adapter with FlexiAdapt® coupling; L — Large Input; C — ServoCool

See Page 86 for Options and Part Number Configuration.

PHA



"PHA" Series – Advanced ServoFit® Precision Planetary Gearhead Selection Data



P
H
A

Part Number (Gearhead + Input)	Exact Ratio i	Maximum Input Speed		Motor Shaft ØD ⁶ mm	Input ¹⁾ Inertia J ₁ kgcm ²	Torsional Stiffness per arcmin C ₂		Output Torque					
		Continuous RPM (n ₁)	Cyclic RPM (n ₁)			in.lbs.	Nm	Nominal ²⁾ M _{2N}		Acceleration M _{2B}		Peak ³⁾ M _{2PEAK}	
								in.lbs.	Nm	in.lbs.	Nm	in.lbs.	Nm
PHA522 with Motor Mounting Plate Continued													
PHA522F0500 MF	50.00	4,000	7,000	≤14	1.69	581.5	65.6	1,949	220	2,835	320	5,315	600
PHA522F0500 MF	50.00	4,000	7,000	>14≤19	1.69	581.5	65.6	1,949	220	2,835	320	5,315	600
PHA522F0500 MF	50.00	4,000	7,000	>19≤24	1.59	581.5	65.6	1,949	220	2,835	320	5,315	600
PHA522F0500 MFC	50.00	5,000	7,000	≤14	2.03	581.5	65.6	1,949	220	2,835	320	5,315	600
PHA522F0500 MFC	50.00	5,000	7,000	>14≤19	1.85	581.8	65.7	1,949	220	2,835	320	5,315	600
PHA522F0500 MFC	50.00	5,000	7,000	>19≤24	1.75	581.5	65.6	1,949	220	2,835	320	5,315	600
PHA522F0500 MFL	50.00	4,000	7,000	>24≤32	4.75	582.0	65.7	1,949	220	2,835	320	5,315	600
PHA522F0500 MFLC	50.00	5,000	7,000	>24≤32	5.18	582.0	65.7	1,949	220	2,835	320	5,315	600
PHA522F0700 MF	70.00	4,000	7,000	≤14	1.69	580.0	65.5	1,860	210	2,392	270	5,315	600
PHA522F0700 MF	70.00	4,000	7,000	>14≤19	1.69	580.0	65.5	1,860	210	2,392	270	5,315	600
PHA522F0700 MF	70.00	4,000	7,000	>19≤24	1.59	580.0	65.5	1,860	210	2,392	270	5,315	600
PHA522F0700 MFC	70.00	5,000	7,000	≤14	2.02	580.0	65.5	1,860	210	2,392	270	5,315	600
PHA522F0700 MFC	70.00	5,000	7,000	>14≤19	1.85	580.1	65.5	1,860	210	2,392	270	5,315	600
PHA522F0700 MFC	70.00	5,000	7,000	>19≤24	1.74	580.0	65.5	1,860	210	2,392	270	5,315	600
PHA522F0700 MFL	70.00	4,000	7,000	>24≤32	4.75	580.2	65.5	1,860	210	2,392	270	5,315	600
PHA522F0700 MFLC	70.00	5,000	7,000	>24≤32	5.18	580.2	65.5	1,860	210	2,392	270	5,315	600
PHA522F1000 MF	100.0	4,000	7,000	≤14	1.69	458.9	51.8	1,240	140	2,215	250	4,429	500
PHA522F1000 MF	100.0	4,000	7,000	>14≤19	1.69	458.9	51.8	1,240	140	2,215	250	4,429	500
PHA522F1000 MF	100.0	4,000	7,000	>19≤24	1.59	458.9	51.8	1,240	140	2,215	250	4,429	500
PHA522F1000 MFC	100.0	5,000	7,000	≤14	2.02	458.9	51.8	1,240	140	2,215	250	4,429	500
PHA522F1000 MFC	100.0	5,000	7,000	>14≤19	1.84	459.0	51.8	1,240	140	2,215	250	4,429	500
PHA522F1000 MFC	100.0	5,000	7,000	>19≤24	1.74	458.9	51.8	1,240	140	2,215	250	4,429	500
PHA522F1000 MFL	100.0	4,000	7,000	>24≤32	4.75	459.0	51.8	1,240	140	2,215	250	4,429	500
PHA522F1000 MFLC	100.0	5,000	7,000	>24≤32	5.18	459.0	51.8	1,240	140	2,215	250	4,429	500

PHA721 with Motor Mounting Plate Continued Next Page

PHA721F0040 MF	4.000	1,900	4,000	≤24	16.29	1,203.8	135.9	3,898	440	6,201	700	8,844	998
PHA721F0040 MF	4.000	1,900	4,000	>24≤32	16.63	1,271.3	143.5	3,898	440	6,201	700	11,803	1,332
PHA721F0040 MF	4.000	1,900	4,000	>32≤38	16.63	1,271.3	143.5	3,898	440	6,201	700	12,235	1,381
PHA721F0040 MFC	4.000	2,400	4,000	≤24	21.71	1,203.8	135.9	3,898	440	5,087	574	6,358	718
PHA721F0040 MFC	4.000	2,400	4,000	>24≤32	20.83	1,271.3	143.5	3,898	440	6,201	700	11,803	1,332
PHA721F0040 MFC	4.000	2,400	4,000	>32≤38	22.42	1,271.3	143.5	3,898	440	6,201	700	12,235	1,381
PHA721F0040 MFL	4.000	1,900	4,000	>38≤48	35.43	1,417.3	160.0	3,898	440	6,201	700	12,235	1,381
PHA721F0040 MFLC	4.000	2,400	4,000	>38≤48	51.29	1,417.3	160.0	3,898	440	6,201	700	12,235	1,381
PHA721F0050 MF	5.000	2,200	5,000	≤24	14.45	1,325.1	149.6	3,898	440	6,201	700	11,055	1,248
PHA721F0050 MF	5.000	2,200	5,000	>24≤32	14.78	1,376.6	155.4	3,898	440	6,201	700	12,401	1,400
PHA721F0050 MF	5.000	2,200	5,000	>32≤38	14.78	1,376.6	155.4	3,898	440	6,201	700	12,401	1,400
PHA721F0050 MFC	5.000	3,000	5,000	≤24	19.86	1,325.1	149.6	3,898	440	6,201	700	7,948	897
PHA721F0050 MFC	5.000	3,000	5,000	>24≤32	18.98	1,376.6	155.4	3,898	440	6,201	700	12,401	1,400
PHA721F0050 MFC	5.000	3,000	5,000	>32≤38	20.58	1,376.6	155.4	3,898	440	6,201	700	12,401	1,400
PHA721F0050 MFL	5.000	2,200	5,000	>38≤48	33.58	1,482.4	167.4	3,898	440	6,201	700	12,401	1,400
PHA721F0050 MFLC	5.000	3,000	5,000	>38≤48	49.44	1,482.4	167.4	3,898	440	6,201	700	12,401	1,400
PHA721F0070 MF	7.000	2,500	5,000	≤24	13.03	1,286.0	145.2	3,898	440	5,758	650	11,127	1,256
PHA721F0070 MF	7.000	2,500	5,000	>24≤32	13.03	1,286.0	145.2	3,898	440	5,758	650	11,127	1,256
PHA721F0070 MF	7.000	2,500	5,000	>32≤38	13.03	1,286.0	145.2	3,898	440	5,758	650	11,127	1,256
PHA721F0070 MFC	7.000	3,500	5,000	≤24	18.44	1,286.0	145.2	3,898	440	5,758	650	11,127	1,256
PHA721F0070 MFC	7.000	3,500	5,000	>24≤32	17.23	1,286.0	145.2	3,898	440	5,758	650	11,127	1,256
PHA721F0070 MFC	7.000	3,500	5,000	>32≤38	18.82	1,286.0	145.2	3,898	440	5,758	650	11,127	1,256
PHA721F0070 MFL	7.000	2,500	5,000	>38≤48	32.18	1,347.4	152.1	3,898	440	5,758	650	11,127	1,256
PHA721F0070 MFLC	7.000	3,500	5,000	>38≤48	48.04	1,347.4	152.1	3,898	440	5,758	650	11,127	1,256

¹⁾ Inertia based on maximum input. For lower inertia using smaller diameter input, contact STOBER.

²⁾ Based on input speed: n₁ = 2000 RPM

For torque at higher input speeds (M_{2NX}) solve the formula, where n₁ = Actual Input Speed.
$$M_{2NX} = \frac{M_{2N}}{\sqrt[3]{\frac{n_1}{2000}}}$$

³⁾ Maximum momentary torque for emergency stops or heavy shock load. Admissible stops per life of gearhead = 1,000 stops maximum.



"PHA" Series – Advanced ServoFit® Precision Planetary Gearhead Selection Data



Part Number (Gearhead + Input)	Exact Ratio i	Maximum Input Speed		Motor Shaft ØD ⁶ mm	Input ¹⁾ Inertia J ₁ kgcm ²	Torsional Stiffness per arcmin		Output Torque					
		Continuous RPM (n _i)	Cyclic RPM (n _c)			C ₂		Nominal ²⁾ M _{2N}		Acceleration M _{2B}		Peak ³⁾ M _{2PEAK}	
						in.lbs.	Nm	in.lbs.	Nm	in.lbs.	Nm	in.lbs.	Nm
PHA721 with Motor Mounting Plate <i>Continued</i>													
PHA721F0100 MF	10.00	3,000	5,000	≤24	12.33	999.8	112.9	2,657	300	4,429	500	8,858	1,000
PHA721F0100 MF	10.00	3,000	5,000	>24≤32	12.33	999.8	112.9	2,657	300	4,429	500	8,858	1,000
PHA721F0100 MF	10.00	3,000	5,000	>32≤38	12.33	999.8	112.9	2,657	300	4,429	500	8,858	1,000
PHA721F0100 MFC	10.00	4,000	5,000	≤24	17.75	999.8	112.9	2,657	300	4,429	500	8,858	1,000
PHA721F0100 MFC	10.00	4,000	5,000	>24≤32	16.54	999.8	112.9	2,657	300	4,429	500	8,858	1,000
PHA721F0100 MFC	10.00	4,000	5,000	>32≤38	18.13	999.8	112.9	2,657	300	4,429	500	8,858	1,000
PHA721F0100 MFL	10.00	3,000	5,000	>38≤48	31.49	1,017.5	114.9	2,657	300	4,429	500	8,858	1,000
PHA721F0100 MFLC	10.00	4,000	5,000	>38≤48	47.35	1,017.5	114.9	2,657	300	4,429	500	8,858	1,000

PHA722 with Motor Mounting Plate <i>Continued Next Page</i>													
PHA722F0160 MF	16.00	3,000	5,000	≤19	6.01	1,170.2	132.1	3,898	440	6,201	700	11,746	1,326
PHA722F0160 MF	16.00	3,000	5,000	>19≤24	6.08	1,176.4	132.8	3,898	440	6,201	700	12,235	1,381
PHA722F0160 MF	16.00	3,000	5,000	>24≤32	5.98	1,176.4	132.8	3,898	440	6,201	700	12,235	1,381
PHA722F0160 MF	16.00	3,000	5,000	>32≤35	5.98	1,176.4	132.8	3,898	440	6,201	700	12,235	1,381
PHA722F0160 MFC	16.00	4,000	5,000	≤19	6.92	1,170.2	132.1	3,898	440	6,201	700	11,746	1,326
PHA722F0160 MFC	16.00	4,000	5,000	>19≤24	6.53	1,176.4	132.8	3,898	440	6,201	700	12,235	1,381
PHA722F0160 MFC	16.00	4,000	5,000	>24≤32	6.41	1,176.4	132.8	3,898	440	6,201	700	12,235	1,381
PHA722F0160 MFL	16.00	3,000	5,000	>32≤38	13.17	1,189.0	134.2	3,898	440	6,201	700	12,235	1,381
PHA722F0160 MFLC	16.00	4,000	5,000	>32≤38	15.97	1,189.0	134.2	3,898	440	6,201	700	12,235	1,381
PHA722F0200 MF	20.00	3,000	5,000	≤19	5.89	1,298.9	146.6	3,898	440	6,201	700	12,401	1,400
PHA722F0200 MF	20.00	3,000	5,000	>19≤24	5.97	1,303.7	147.2	3,898	440	6,201	700	12,401	1,400
PHA722F0200 MF	20.00	3,000	5,000	>24≤32	5.87	1,303.7	147.2	3,898	440	6,201	700	12,401	1,400
PHA722F0200 MF	20.00	3,000	5,000	>32≤35	5.87	1,303.7	147.2	3,898	440	6,201	700	12,401	1,400
PHA722F0200 MFC	20.00	4,000	5,000	≤19	6.81	1,298.9	146.6	3,898	440	6,201	700	12,401	1,400
PHA722F0200 MFC	20.00	4,000	5,000	>19≤24	6.42	1,303.7	147.2	3,898	440	6,201	700	12,401	1,400
PHA722F0200 MFC	20.00	4,000	5,000	>24≤32	6.30	1,303.7	147.2	3,898	440	6,201	700	12,401	1,400
PHA722F0200 MFL	20.00	3,000	5,000	>32≤38	13.06	1,313.6	148.3	3,898	440	6,201	700	12,401	1,400
PHA722F0200 MFLC	20.00	4,000	5,000	>32≤38	15.85	1,313.6	148.3	3,898	440	6,201	700	12,401	1,400
PHA722F0250 MF	25.00	3,500	6,000	≤19	5.48	1,300.8	146.8	3,898	440	6,201	700	12,401	1,400
PHA722F0250 MF	25.00	3,500	6,000	>19≤24	5.56	1,303.9	147.2	3,898	440	6,201	700	12,401	1,400
PHA722F0250 MF	25.00	3,500	6,000	>24≤32	5.46	1,303.9	147.2	3,898	440	6,201	700	12,401	1,400
PHA722F0250 MF	25.00	3,500	6,000	>32≤35	5.46	1,303.9	147.2	3,898	440	6,201	700	12,401	1,400
PHA722F0250 MFC	25.00	4,200	6,000	≤19	6.40	1,300.8	146.8	3,898	440	6,201	700	12,401	1,400
PHA722F0250 MFC	25.00	4,200	6,000	>19≤24	6.01	1,303.9	147.2	3,898	440	6,201	700	12,401	1,400
PHA722F0250 MFC	25.00	4,200	6,000	>24≤32	5.89	1,303.9	147.2	3,898	440	6,201	700	12,401	1,400
PHA722F0250 MFL	25.00	3,500	6,000	>32≤38	12.65	1,310.2	147.9	3,898	440	6,201	700	12,401	1,400
PHA722F0250 MFLC	25.00	4,200	6,000	>32≤38	15.44	1,310.2	147.9	3,898	440	6,201	700	12,401	1,400
PHA722F0280 MF	28.00	3,700	6,500	≤19	5.18	1,149.1	129.7	3,898	440	6,201	700	12,235	1,381
PHA722F0280 MF	28.00	3,700	6,500	>19≤24	5.18	1,149.1	129.7	3,898	440	6,201	700	12,235	1,381
PHA722F0280 MF	28.00	3,700	6,500	>24≤32	5.08	1,149.1	129.7	3,898	440	6,201	700	12,235	1,381
PHA722F0280 MF	28.00	3,700	6,500	>32≤35	5.08	1,149.1	129.7	3,898	440	6,201	700	12,235	1,381
PHA722F0280 MFC	28.00	4,500	6,500	≤19	6.10	1,149.1	129.7	3,898	440	6,201	700	12,235	1,381
PHA722F0280 MFC	28.00	4,500	6,500	>19≤24	5.63	1,149.1	129.7	3,898	440	6,201	700	12,235	1,381
PHA722F0280 MFC	28.00	4,500	6,500	>24≤32	5.51	1,149.1	129.7	3,898	440	6,201	700	12,235	1,381
PHA722F0280 MFL	28.00	3,700	6,500	>32≤38	12.01	1,153.8	130.3	3,898	440	6,201	700	12,235	1,381
PHA722F0280 MFLC	28.00	4,500	6,500	>32≤38	14.81	1,153.8	130.3	3,898	440	6,201	700	12,235	1,381
PHA722F0350 MF	35.00	3,700	6,500	≤19	5.15	1,282.2	144.7	3,898	440	6,201	700	12,401	1,400
PHA722F0350 MF	35.00	3,700	6,500	>19≤24	5.15	1,282.2	144.7	3,898	440	6,201	700	12,401	1,400
PHA722F0350 MF	35.00	3,700	6,500	>24≤32	5.05	1,282.2	144.7	3,898	440	6,201	700	12,401	1,400

Index of Symbols: MF — Motor adapter with FlexiAdapt® coupling; L — Large Input; C — ServoCool

See Page 86 for Options and Part Number Configuration.

P
H
A



"PHA" Series – Advanced ServoFit® Precision Planetary Gearhead Selection Data



P
H
A

Part Number (Gearhead + Input)	Exact Ratio i	Maximum Input Speed		Motor Shaft ØD ⁶ mm	Input ¹⁾ Inertia J ₁ kgcm ²	Torsional Stiffness per arcmin		Output Torque					
		Continuous RPM (n ₁)	Cyclic RPM (n ₁)			C ₂	Nominal ²⁾		Acceleration		Peak ³⁾		
							M _{2N}	M _{2B}	M _{2N}	M _{2B}	M _{2PEAK}	M _{2PEAK}	
Gearhead						in.lbs.	Nm	in.lbs.	Nm	in.lbs.	Nm	in.lbs.	Nm
PHA722 with Motor Mounting Plate <i>Continued</i>													
PHA722F0350 MF	35.00	3,700	6,500	>32≤35	5.05	1,282.2	144.7	3,898	440	6,201	700	12,401	1,400
PHA722F0350 MFC	35.00	4,500	6,500	≤19	6.06	1,282.2	144.7	3,898	440	6,201	700	12,401	1,400
PHA722F0350 MFL	35.00	4,500	6,500	>19≤24	5.60	1,282.2	144.7	3,898	440	6,201	700	12,401	1,400
PHA722F0350 MFLC	35.00	4,500	6,500	>24≤32	5.48	1,282.2	144.7	3,898	440	6,201	700	12,401	1,400
PHA722F0400 MF	40.00	3,700	6,500	>32≤38	11.98	1,285.8	145.2	3,898	440	6,201	700	12,401	1,400
PHA722F0400 MFC	40.00	4,500	6,500	>32≤38	14.77	1,285.8	145.2	3,898	440	6,201	700	12,401	1,400
PHA722F0400 MFL	40.00	3,700	6,500	≤19	4.99	1,115.6	125.9	3,898	440	6,201	700	12,235	1,381
PHA722F0400 MFLC	40.00	3,700	6,500	>19≤24	4.99	1,115.6	125.9	3,898	440	6,201	700	12,235	1,381
PHA722F0500 MF	50.00	3,700	6,500	>24≤32	4.89	1,115.6	125.9	3,898	440	6,201	700	12,235	1,381
PHA722F0500 MFC	50.00	3,700	6,500	>32≤35	4.89	1,115.6	125.9	3,898	440	6,201	700	12,235	1,381
PHA722F0500 MFL	50.00	4,700	6,500	≤19	5.91	1,115.6	125.9	3,898	440	6,201	700	12,235	1,381
PHA722F0500 MFLC	50.00	4,700	6,500	>19≤24	5.44	1,115.6	125.9	3,898	440	6,201	700	12,235	1,381
PHA722F0700 MF	70.00	3,700	6,500	>24≤32	5.32	1,115.6	125.9	3,898	440	6,201	700	12,235	1,381
PHA722F0700 MFC	70.00	3,700	6,500	>32≤38	11.82	1,117.7	126.2	3,898	440	6,201	700	12,235	1,381
PHA722F0700 MFL	70.00	4,700	6,500	>32≤38	14.62	1,117.7	126.2	3,898	440	6,201	700	12,235	1,381
PHA722F0700 MFLC	70.00	4,700	6,500	≤19	4.98	1,255.2	141.7	3,898	440	6,201	700	12,401	1,400
PHA722F0500 MF	50.00	3,700	6,500	>19≤24	4.98	1,255.2	141.7	3,898	440	6,201	700	12,401	1,400
PHA722F0500 MFC	50.00	3,700	6,500	>24≤32	4.88	1,255.2	141.7	3,898	440	6,201	700	12,401	1,400
PHA722F0500 MFL	50.00	3,700	6,500	>32≤35	4.88	1,255.2	141.7	3,898	440	6,201	700	12,401	1,400
PHA722F0500 MFLC	50.00	4,700	6,500	≤19	5.89	1,255.2	141.7	3,898	440	6,201	700	12,401	1,400
PHA722F0700 MF	70.00	4,700	6,500	>19≤24	5.43	1,255.2	141.7	3,898	440	6,201	700	12,401	1,400
PHA722F0700 MFC	70.00	4,700	6,500	>24≤32	5.31	1,255.2	141.7	3,898	440	6,201	700	12,401	1,400
PHA722F0700 MFL	70.00	3,700	6,500	>32≤38	11.80	1,256.9	141.9	3,898	440	6,201	700	12,401	1,400
PHA722F0700 MFLC	70.00	4,700	6,500	>32≤38	14.60	1,256.9	141.9	3,898	440	6,201	700	12,401	1,400
PHA722F1000 MF	100.0	3,700	6,500	≤19	4.96	1,251.5	141.3	3,898	440	5,758	650	11,127	1,256
PHA722F1000 MFC	100.0	3,700	6,500	>19≤24	4.96	1,251.5	141.3	3,898	440	5,758	650	11,127	1,256
PHA722F1000 MFL	100.0	3,700	6,500	>24≤32	4.86	1,251.5	141.3	3,898	440	5,758	650	11,127	1,256
PHA722F1000 MFLC	100.0	3,700	6,500	>32≤35	4.86	1,251.5	141.3	3,898	440	5,758	650	11,127	1,256
PHA722F0700 MF	70.00	4,700	6,500	≤19	5.87	1,251.5	141.3	3,898	440	5,758	650	11,127	1,256
PHA722F0700 MFC	70.00	4,700	6,500	>19≤24	5.41	1,251.5	141.3	3,898	440	5,758	650	11,127	1,256
PHA722F0700 MFL	70.00	4,700	6,500	>24≤32	5.29	1,251.5	141.3	3,898	440	5,758	650	11,127	1,256
PHA722F0700 MFLC	70.00	3,700	6,500	>32≤38	11.79	1,252.4	141.4	3,898	440	5,758	650	11,127	1,256
PHA722F1000 MF	100.0	4,700	6,500	>32≤38	14.59	1,252.4	141.4	3,898	440	5,758	650	11,127	1,256
PHA722F1000 MFC	100.0	3,700	6,500	≤19	4.95	989.4	111.7	2,657	300	4,429	500	8,858	1,000
PHA722F1000 MFL	100.0	3,700	6,500	>19≤24	4.95	989.4	111.7	2,657	300	4,429	500	8,858	1,000
PHA722F1000 MFLC	100.0	3,700	6,500	>24≤32	4.85	989.4	111.7	2,657	300	4,429	500	8,858	1,000
PHA722F0700 MF	70.00	3,700	6,500	>32≤35	4.85	989.4	111.7	2,657	300	4,429	500	8,858	1,000
PHA722F0500 MF	50.00	4,700	6,500	≤19	5.87	989.4	111.7	2,657	300	4,429	500	8,858	1,000
PHA722F0500 MFC	50.00	4,700	6,500	>19≤24	5.40	989.4	111.7	2,657	300	4,429	500	8,858	1,000
PHA722F0500 MFL	50.00	4,700	6,500	>24≤32	5.28	989.4	111.7	2,657	300	4,429	500	8,858	1,000
PHA722F0500 MFLC	50.00	3,700	6,500	>32≤38	11.78	989.7	111.7	2,657	300	4,429	500	8,858	1,000
PHA722F1000 MF	100.0	4,700	6,500	>32≤38	14.58	989.7	111.7	2,657	300	4,429	500	8,858	1,000

PHA821 with Motor Mounting Plate *Continued Next Page*

PHA821F0040 MF	4.000	1,500	3,500	≤32	55.66	3,331.7	376.1	7,086	800	14,173	1,600	17,245	1,947
PHA821F0040 MFC	4.000	1,500	3,500	>32≤38	55.46	3,527.3	398.2	7,086	800	14,173	1,600	20,477	2,312
PHA821F0040 MFL	4.000	1,500	3,500	>38≤48	54.82	3,527.3	398.2	7,086	800	14,173	1,600	22,752	2,569
PHA821F0040 MFLC	4.000	2,200	3,500	≤32	68.17	3,331.7	376.1	7,086	800	11,383	1,285	14,229	1,606
PHA821F0040 MFC	4.000	2,200	3,500	>32≤38	70.14	3,527.3	398.2	7,086	800	14,173	1,600	20,477	2,312
PHA821F0040 MFLC	4.000	2,200	3,500	>38≤48	69.89	3,527.3	398.2	7,086	800	14,173	1,600	22,752	2,569

¹⁾ Inertia based on maximum input. For lower inertia using smaller diameter input, contact STOBER.

²⁾ Based on input speed: n₁ = 2000 RPM

For torque at higher input speeds (M_{2Nx}) solve the formula, where n₁ = Actual Input Speed.
$$M_{2Nx} = \frac{M_{2N}}{\sqrt[3]{\frac{n_1}{2000}}}$$

³⁾ Maximum momentary torque for emergency stops or heavy shock load. Admissible stops per life of gearhead = 1,000 stops maximum.



"PHA" Series – Advanced ServoFit® Precision Planetary Gearhead Selection Data



Part Number (Gearhead + Input)	Exact Ratio i	Maximum Input Speed		Motor Shaft ØD ⁶ mm	Input ¹⁾ Inertia J ₁ kgcm ²	Torsional Stiffness per arcmin C ₂		Output Torque					
		Continuous RPM (n _i)	Cyclic RPM (n _i)			in.lbs.	Nm	Nominal ²⁾ M _{2N}		Acceleration M _{2B}		Peak ³⁾ M _{2PEAK}	
								in.lbs.	Nm	in.lbs.	Nm	in.lbs.	Nm
PHA821 with Motor Mounting Plate <i>Continued</i>													
PHA821F0050 MF	5.000	1,700	4,000	≤32	46.67	3,610.9	407.6	8,858	1,000	15,059	1,700	21,557	2,434
PHA821F0050 MF	5.000	1,700	4,000	>32≤38	46.47	3,755.4	424.0	8,858	1,000	15,059	1,700	25,596	2,890
PHA821F0050 MF	5.000	1,700	4,000	>38≤48	45.84	3,755.4	424.0	8,858	1,000	15,059	1,700	28,346	3,200
PHA821F0050 MFC	5.000	2,500	4,000	≤32	59.18	3,610.9	407.6	8,858	1,000	14,229	1,606	17,786	2,008
PHA821F0050 MFC	5.000	2,500	4,000	>32≤38	61.15	3,755.4	424.0	8,858	1,000	15,059	1,700	25,596	2,890
PHA821F0050 MFC	5.000	2,500	4,000	>38≤48	60.91	3,755.4	424.0	8,858	1,000	15,059	1,700	28,346	3,200
PHA821F0070 MF	7.000	2,000	4,000	≤32	39.26	3,546.2	400.3	8,858	1,000	14,173	1,600	24,900	2,811
PHA821F0070 MF	7.000	2,000	4,000	>32≤38	39.05	3,546.2	400.3	8,858	1,000	14,173	1,600	24,900	2,811
PHA821F0070 MF	7.000	2,000	4,000	>38≤48	38.42	3,546.2	400.3	8,858	1,000	14,173	1,600	24,900	2,811
PHA821F0070 MFC	7.000	3,200	4,000	≤32	51.74	3,546.2	400.3	8,858	1,000	14,173	1,600	24,900	2,811
PHA821F0070 MFC	7.000	3,200	4,000	>32≤38	53.73	3,546.2	400.3	8,858	1,000	14,173	1,600	24,900	2,811
PHA821F0070 MFC	7.000	3,200	4,000	>38≤48	53.49	3,546.2	400.3	8,858	1,000	14,173	1,600	24,900	2,811
PHA821F0100 MF	10.00	2,500	4,000	≤32	35.44	2,657.4	300.0	7,086	800	10,630	1,200	21,259	2,400
PHA821F0100 MF	10.00	2,500	4,000	>32≤38	35.24	2,657.4	300.0	7,086	800	10,630	1,200	21,259	2,400
PHA821F0100 MF	10.00	2,500	4,000	>38≤48	34.60	2,657.4	300.0	7,086	800	10,630	1,200	21,259	2,400
PHA821F0100 MFC	10.00	3,700	4,500	≤32	47.93	2,657.4	300.0	7,086	800	10,630	1,200	21,259	2,400
PHA821F0100 MFC	10.00	3,700	4,500	>32≤38	49.92	2,657.4	300.0	7,086	800	10,630	1,200	21,259	2,400
PHA821F0100 MFC	10.00	3,700	4,500	>38≤48	49.67	2,657.4	300.0	7,086	800	10,630	1,200	21,259	2,400

PHA822 with Motr Mounting Plate *Continued Next Page*

PHA822F0160 MF	16.00	2,500	4,500	≤24	16.24	3,129.6	353.3	9,744	1,100	17,716	2,000	24,416	2,756
PHA822F0160 MF	16.00	2,500	4,500	>24≤32	16.57	3,156.8	356.4	9,744	1,100	17,716	2,000	28,346	3,200
PHA822F0160 MF	16.00	2,500	4,500	>32≤38	16.57	3,156.8	356.4	9,744	1,100	17,716	2,000	28,346	3,200
PHA822F0160 MFC	16.00	3,250	4,500	≤24	18.99	3,156.8	356.4	9,744	1,100	17,716	2,000	28,346	3,200
PHA822F0160 MFC	16.00	3,250	4,500	>24≤32	17.77	3,156.8	356.4	9,744	1,100	17,716	2,000	28,346	3,200
PHA822F0160 MFC	16.00	3,250	4,500	>32≤38	19.37	3,156.8	356.4	9,744	1,100	17,716	2,000	28,346	3,200
PHA822F0160 MFL	16.00	2,500	4,500	>38≤48	18.59	3,208.1	362.2	9,744	1,100	17,716	2,000	28,346	3,200
PHA822F0160 MFLC	16.00	3,250	4,500	>38≤48	34.45	3,208.1	362.2	9,744	1,100	17,716	2,000	28,346	3,200
PHA822F0200 MF	20.00	2,500	4,500	≤24	15.68	3,456.1	390.2	11,073	1,250	17,716	2,000	28,346	3,200
PHA822F0200 MF	20.00	2,500	4,500	>24≤32	16.01	3,477.3	392.6	11,073	1,250	17,716	2,000	28,346	3,200
PHA822F0200 MF	20.00	2,500	4,500	>32≤38	16.01	3,477.3	392.6	11,073	1,250	17,716	2,000	28,346	3,200
PHA822F0200 MFC	20.00	3,300	4,500	≤24	18.43	3,477.3	392.6	11,073	1,250	17,716	2,000	28,346	3,200
PHA822F0200 MFC	20.00	3,300	4,500	>24≤32	17.21	3,477.3	392.6	11,073	1,250	17,716	2,000	28,346	3,200
PHA822F0200 MFC	20.00	3,300	4,500	>32≤38	18.80	3,477.3	392.6	11,073	1,250	17,716	2,000	28,346	3,200
PHA822F0200 MFL	20.00	2,500	4,500	>38≤48	18.02	3,517.0	397.0	11,073	1,250	17,716	2,000	28,346	3,200
PHA822F0200 MFLC	20.00	3,300	4,500	>38≤48	33.88	3,517.0	397.0	11,073	1,250	17,716	2,000	28,346	3,200
PHA822F0250 MF	25.00	3,000	5,500	≤24	14.16	3,455.0	390.0	11,073	1,250	17,716	2,000	28,346	3,200
PHA822F0250 MF	25.00	3,000	5,500	>24≤32	14.50	3,468.5	391.6	11,073	1,250	17,716	2,000	28,346	3,200
PHA822F0250 MF	25.00	3,000	5,500	>32≤38	14.50	3,468.5	391.6	11,073	1,250	17,716	2,000	28,346	3,200
PHA822F0250 MFC	25.00	3,800	5,500	≤24	16.91	3,468.5	391.6	11,073	1,250	17,716	2,000	28,346	3,200
PHA822F0250 MFC	25.00	3,800	5,500	>24≤32	15.70	3,468.5	391.6	11,073	1,250	17,716	2,000	28,346	3,200
PHA822F0250 MFC	25.00	3,800	5,500	>32≤38	17.29	3,468.5	391.6	11,073	1,250	17,716	2,000	28,346	3,200
PHA822F0250 MFL	25.00	3,000	5,500	>38≤48	16.51	3,493.7	394.4	11,073	1,250	17,716	2,000	28,346	3,200
PHA822F0250 MFLC	25.00	3,800	5,500	>38≤48	32.37	3,493.7	394.4	11,073	1,250	17,716	2,000	28,346	3,200
PHA822F0280 MF	28.00	3,300	6,000	≤24	13.08	3,115.8	351.8	9,744	1,100	17,716	2,000	28,346	3,200
PHA822F0280 MF	28.00	3,300	6,000	>24≤32	13.08	3,115.8	351.8	9,744	1,100	17,716	2,000	28,346	3,200
PHA822F0280 MF	28.00	3,300	6,000	>32≤38	13.08	3,115.8	351.8	9,744	1,100	17,716	2,000	28,346	3,200
PHA822F0280 MFC	28.00	4,000	6,000	≤24	15.49	3,115.8	351.8	9,744	1,100	17,716	2,000	28,346	3,200
PHA822F0280 MFC	28.00	4,000	6,000	>24≤32	14.28	3,115.8	351.8	9,744	1,100	17,716	2,000	28,346	3,200
PHA822F0280 MFC	28.00	4,000	6,000	>32≤38	15.87	3,115.8	351.8	9,744	1,100	17,716	2,000	28,346	3,200
PHA822F0280 MFL	28.00	3,300	6,000	>38≤48	15.45	3,137.5	354.2	9,744	1,100	17,716	2,000	28,346	3,200
PHA822F0280 MFLC	28.00	4,000	6,000	>38≤48	31.31	3,137.5	354.2	9,744	1,100	17,716	2,000	28,346	3,200

Index of Symbols: MF — Motor adapter with FlexiAdapt® coupling; L — Large Input; C — ServoCool

See Page 86 for Options and Part Number Configuration.



"PHA" Series – Advanced ServoFit® Precision Planetary Gearhead Selection Data



P
H
A

Part Number (Gearhead + Input)	Exact Ratio i	Maximum Input Speed		Motor Shaft ØD ⁶ mm	Input ¹⁾ Inertia J ₁ kgcm ²	Torsional Stiffness per arcmin		Output Torque					
		Continuous RPM (n ₁)	Cyclic RPM (n ₂)			C ₂	Nominal ²⁾		Acceleration		Peak ³⁾		
							M _{2N}	M _{2B}	M _{2N}	M _{2B}	M _{2PEAK}	M _{2PEAK}	
Gearhead						in.lbs.	Nm	in.lbs.	Nm	in.lbs.	Nm	in.lbs.	Nm
PHA822 with Motor Mounting Plate Continued													
PHA822F0350 MF	35.00	3,300	6,000	≤24	12.89	3,445.4	389.0	11,073	1,250	17,716	2,000	28,346	3,200
PHA822F0350 MF	35.00	3,300	6,000	>24≤32	12.89	3,445.4	389.0	11,073	1,250	17,716	2,000	28,346	3,200
PHA822F0350 MF	35.00	3,300	6,000	>32≤38	12.89	3,445.4	389.0	11,073	1,250	17,716	2,000	28,346	3,200
PHA822F0350 MFC	35.00	4,000	6,000	≤24	15.31	3,445.4	389.0	11,073	1,250	17,716	2,000	28,346	3,200
PHA822F0350 MFC	35.00	4,000	6,000	>24≤32	14.10	3,445.4	389.0	11,073	1,250	17,716	2,000	28,346	3,200
PHA822F0350 MFC	35.00	4,000	6,000	>32≤38	15.69	3,445.4	389.0	11,073	1,250	17,716	2,000	28,346	3,200
PHA822F0350 MFL	35.00	3,300	6,000	>38≤48	15.26	3,462.3	390.9	11,073	1,250	17,716	2,000	28,346	3,200
PHA822F0350 MFLC	35.00	4,000	6,000	>38≤48	31.12	3,462.3	390.9	11,073	1,250	17,716	2,000	28,346	3,200
PHA822F0400 MF	40.00	3,300	6,000	≤24	12.36	3,003.9	339.1	9,744	1,100	17,007	1,920	28,346	3,200
PHA822F0400 MF	40.00	3,300	6,000	>24≤32	12.36	3,003.9	339.1	9,744	1,100	17,007	1,920	28,346	3,200
PHA822F0400 MF	40.00	3,300	6,000	>32≤38	12.36	3,003.9	339.1	9,744	1,100	17,007	1,920	28,346	3,200
PHA822F0400 MFC	40.00	4,300	6,000	≤24	14.77	3,003.9	339.1	9,744	1,100	17,007	1,920	28,346	3,200
PHA822F0400 MFC	40.00	4,300	6,000	>24≤32	13.56	3,003.9	339.1	9,744	1,100	17,007	1,920	28,346	3,200
PHA822F0400 MFC	40.00	4,300	6,000	>32≤38	15.15	3,003.9	339.1	9,744	1,100	17,007	1,920	28,346	3,200
PHA822F0400 MFL	40.00	3,300	6,000	>38≤48	14.73	3,013.7	340.2	9,744	1,100	17,007	1,920	28,346	3,200
PHA822F0400 MFLC	40.00	4,300	6,000	>38≤48	30.59	3,013.7	340.2	9,744	1,100	17,007	1,920	28,346	3,200
PHA822F0500 MF	50.00	3,300	6,000	≤24	12.27	3,356.9	379.0	11,073	1,250	17,716	2,000	28,346	3,200
PHA822F0500 MF	50.00	3,300	6,000	>24≤32	12.27	3,356.9	379.0	11,073	1,250	17,716	2,000	28,346	3,200
PHA822F0500 MF	50.00	3,300	6,000	>32≤38	12.27	3,356.9	379.0	11,073	1,250	17,716	2,000	28,346	3,200
PHA822F0500 MFC	50.00	4,300	6,000	≤24	14.68	3,356.9	379.0	11,073	1,250	17,716	2,000	28,346	3,200
PHA822F0500 MFC	50.00	4,300	6,000	>24≤32	13.47	3,356.9	379.0	11,073	1,250	17,716	2,000	28,346	3,200
PHA822F0500 MFC	50.00	4,300	6,000	>32≤38	15.06	3,356.9	379.0	11,073	1,250	17,716	2,000	28,346	3,200
PHA822F0500 MFL	50.00	3,300	6,000	>38≤48	14.64	3,364.7	379.9	11,073	1,250	17,716	2,000	28,346	3,200
PHA822F0500 MFLC	50.00	4,300	6,000	>38≤48	30.50	3,364.7	379.9	11,073	1,250	17,716	2,000	28,346	3,200
PHA822F0700 MF	70.00	3,300	6,000	≤24	12.19	3,416.7	385.7	8,858	1,000	14,173	1,600	24,900	2,811
PHA822F0700 MF	70.00	3,300	6,000	>24≤32	12.19	3,416.7	385.7	8,858	1,000	14,173	1,600	24,900	2,811
PHA822F0700 MF	70.00	3,300	6,000	>32≤38	12.19	3,416.7	385.7	8,858	1,000	14,173	1,600	24,900	2,811
PHA822F0700 MFC	70.00	4,300	6,000	≤24	14.61	3,416.7	385.7	8,858	1,000	14,173	1,600	24,900	2,811
PHA822F0700 MFC	70.00	4,300	6,000	>24≤32	13.39	3,416.7	385.7	8,858	1,000	14,173	1,600	24,900	2,811
PHA822F0700 MFC	70.00	4,300	6,000	>32≤38	14.99	3,416.7	385.7	8,858	1,000	14,173	1,600	24,900	2,811
PHA822F0700 MFL	70.00	3,300	6,000	>38≤48	14.56	3,420.8	386.2	8,858	1,000	14,173	1,600	24,900	2,811
PHA822F0700 MFLC	70.00	4,300	6,000	>38≤48	30.42	3,420.8	386.2	8,858	1,000	14,173	1,600	24,900	2,811
PHA822F1000 MF	100.0	3,300	6,000	≤24	12.15	2,620.9	295.9	7,086	800	10,630	1,200	21,259	2,400
PHA822F1000 MF	100.0	3,300	6,000	>24≤32	12.15	2,620.9	295.9	7,086	800	10,630	1,200	21,259	2,400
PHA822F1000 MF	100.0	3,300	6,000	>32≤38	12.15	2,620.9	295.9	7,086	800	10,630	1,200	21,259	2,400
PHA822F1000 MFC	100.0	4,300	6,000	≤24	14.57	2,620.9	295.9	7,086	800	10,630	1,200	21,259	2,400
PHA822F1000 MFC	100.0	4,300	6,000	>24≤32	13.36	2,620.9	295.9	7,086	800	10,630	1,200	21,259	2,400
PHA822F1000 MFC	100.0	4,300	6,000	>32≤38	14.95	2,620.9	295.9	7,086	800	10,630	1,200	21,259	2,400
PHA822F1000 MFL	100.0	3,300	6,000	>38≤48	14.52	2,622.1	296.0	7,086	800	10,630	1,200	21,259	2,400
PHA822F1000 MFLC	100.0	4,300	6,000	>38≤48	30.38	2,622.1	296.0	7,086	800	10,630	1,200	21,259	2,400

PHA932 with Motor Mounting Plate Continued Next Page

PHA932F0120 MF	12.00	1,800	3,000	≤32	81.74	9,660	1,090	26,574	3,000	32,783	3,701	40,979	4,626
PHA932F0120 MF	12.00	1,800	3,000	>32≤38	81.51	9,836	1,110	26,574	3,000	40,818	4,608	59,511	6,718
PHA932F0120 MF	12.00	1,800	3,000	>38≤48	80.88	9,836	1,110	26,574	3,000	40,818	4,608	65,527	7,397
PHA932F0120 MFC	12.00	2,700	3,000	≤32	95.85	9,660	1,090	26,574	3,000	32,783	3,701	40,979	4,626
PHA932F0120 MFC	12.00	2,700	3,000	>32≤38	97.62	9,836	1,110	26,574	3,000	40,818	4,608	59,511	6,718
PHA932F0120 MFC	12.00	2,700	3,000	>38≤48	96.74	9,836	1,110	26,574	3,000	40,818	4,608	65,527	7,397
PHA932F0160 MF	16.00	2,200	3,500	≤32	53.56	9,984	1,127	26,574	3,000	43,711	4,935	54,639	6,168
PHA932F0160 MF	16.00	2,200	3,500	>32≤38	53.34	10,089	1,139	26,574	3,000	44,290	5,000	79,348	8,958
PHA932F0160 MF	16.00	2,200	3,500	>38≤48	52.70	10,089	1,139	26,574	3,000	44,290	5,000	87,369	9,863

¹⁾ Inertia based on maximum input. For lower inertia using smaller diameter input, contact STOBER.

²⁾ Based on input speed: n₁ = 2000 RPM

For torque at higher input speeds (M_{2NX}) solve the formula, where n₁ = Actual Input Speed.
$$M_{2NX} = \frac{M_{2N}}{\sqrt[3]{\frac{n_1}{2000}}}$$

³⁾ Maximum momentary torque for emergency stops or heavy shock load. Admissible stops per life of gearhead = 1,000 stops maximum.



"PHA" Series – Advanced ServoFit® Precision Planetary Gearhead Selection Data



Part Number (Gearhead + Input)	Exact Ratio i	Maximum Input Speed		Motor Shaft ØD ⁶ mm	Input ¹⁾ Inertia J ₁ kgcm ²	Torsional Stiffness per arcmin C ₂		Output Torque					
		Continuous RPM (n _i)	Cyclic RPM (n _c)			in.lbs.	Nm	Nominal ²⁾ M _{2N}		Acceleration M _{2B}		Peak ³⁾ M _{2PEAK}	
								in.lbs.	Nm	in.lbs.	Nm	in.lbs.	Nm

PHA932 with Motor Mounting Plate *Continued Next Page*

PHA932F0160 MFC	16.00	2,900	3,500	≤32	67.68	9,984	1,127	26,574	3,000	43,711	4,935	54,639	6,168
PHA932F0160 MFC	16.00	2,900	3,500	>32≤38	69.44	10,089	1,139	26,574	3,000	44,290	5,000	79,348	8,958
PHA932F0160 MFC	16.00	2,900	3,500	>38≤48	68.56	10,089	1,139	26,574	3,000	44,290	5,000	87,369	9,863
PHA932F0180 MF	18.00	1,800	3,000	≤32	75.69	9,524	1,075	26,574	3,000	39,861	4,500	61,468	6,939
PHA932F0180 MF	18.00	1,800	3,000	>32≤38	75.47	9,599	1,084	26,574	3,000	39,861	4,500	79,722	9,000
PHA932F0180 MF	18.00	1,800	3,000	>38≤48	74.83	9,599	1,084	26,574	3,000	39,861	4,500	79,722	9,000
PHA932F0180 MFC	18.00	2,700	3,000	≤32	89.81	9,524	1,075	26,574	3,000	39,861	4,500	61,468	6,939
PHA932F0180 MFC	18.00	2,700	3,000	>32≤38	91.57	9,599	1,084	26,574	3,000	39,861	4,500	79,722	9,000
PHA932F0180 MFC	18.00	2,700	3,000	>38≤48	90.69	9,599	1,084	26,574	3,000	39,861	4,500	79,722	9,000
PHA932F0200 MF	20.00	2,500	4,000	≤32	44.73	10,047	1,134	26,574	3,000	44,290	5,000	68,298	7,710
PHA932F0200 MF	20.00	2,500	4,000	>32≤38	44.51	10,114	1,142	26,574	3,000	44,290	5,000	88,580	10,000
PHA932F0200 MF	20.00	2,500	4,000	>38≤48	43.87	10,114	1,142	26,574	3,000	44,290	5,000	88,580	10,000
PHA932F0200 MFC	20.00	3,300	4,000	≤32	58.85	10,047	1,134	26,574	3,000	44,290	5,000	68,298	7,710
PHA932F0200 MFC	20.00	3,300	4,000	>32≤38	60.61	10,114	1,142	26,574	3,000	44,290	5,000	88,580	10,000
PHA932F0200 MFC	20.00	3,300	4,000	>38≤48	59.73	10,114	1,142	26,574	3,000	44,290	5,000	88,580	10,000
PHA932F0240 MF	24.00	2,200	3,500	≤32	50.16	9,661	1,091	26,574	3,000	39,861	4,500	79,722	9,000
PHA932F0240 MF	24.00	2,200	3,500	>32≤38	49.94	9,705	1,096	26,574	3,000	39,861	4,500	79,722	9,000
PHA932F0240 MF	24.00	2,200	3,500	>38≤48	49.30	9,705	1,096	26,574	3,000	39,861	4,500	79,722	9,000
PHA932F0240 MFC	24.00	2,900	3,500	≤32	64.27	9,661	1,091	26,574	3,000	39,861	4,500	79,722	9,000
PHA932F0240 MFC	24.00	2,900	3,500	>32≤38	66.04	9,705	1,096	26,574	3,000	39,861	4,500	79,722	9,000
PHA932F0240 MFC	24.00	2,900	3,500	>38≤48	65.16	9,705	1,096	26,574	3,000	39,861	4,500	79,722	9,000
PHA932F0280 MF	28.00	2,800	4,500	≤32	38.30	9,926	1,121	26,574	3,000	44,290	5,000	88,580	10,000
PHA932F0280 MF	28.00	2,800	4,500	>32≤38	38.10	9,926	1,121	26,574	3,000	44,290	5,000	88,580	10,000
PHA932F0280 MF	28.00	2,800	4,500	>38≤48	37.46	9,926	1,121	26,574	3,000	44,290	5,000	88,580	10,000
PHA932F0280 MFC	28.00	4,000	4,500	≤32	52.42	9,926	1,121	26,574	3,000	44,290	5,000	88,580	10,000
PHA932F0280 MFC	28.00	4,000	4,500	>32≤38	54.20	9,926	1,121	26,574	3,000	44,290	5,000	88,580	10,000
PHA932F0280 MFC	28.00	4,000	4,500	>38≤48	53.32	9,926	1,121	26,574	3,000	44,290	5,000	88,580	10,000
PHA932F0300 MF	30.00	2,500	4,000	≤32	42.56	9,687	1,094	26,574	3,000	39,861	4,500	79,722	9,000
PHA932F0300 MF	30.00	2,500	4,000	>32≤38	42.33	9,715	1,097	26,574	3,000	39,861	4,500	79,722	9,000
PHA932F0300 MF	30.00	2,500	4,000	>38≤48	41.69	9,715	1,097	26,574	3,000	39,861	4,500	79,722	9,000
PHA932F0300 MFC	30.00	3,500	4,000	≤32	56.67	9,687	1,094	26,574	3,000	39,861	4,500	79,722	9,000
PHA932F0300 MFC	30.00	3,500	4,000	>32≤38	58.43	9,715	1,097	26,574	3,000	39,861	4,500	79,722	9,000
PHA932F0300 MFC	30.00	3,500	4,000	>38≤48	57.55	9,715	1,097	26,574	3,000	39,861	4,500	79,722	9,000
PHA932F0320 MF	32.00	2,800	4,500	≤32	36.64	9,680	1,093	26,574	3,000	40,818	4,608	88,580	10,000
PHA932F0320 MF	32.00	2,800	4,500	>32≤38	36.44	9,680	1,093	26,574	3,000	40,818	4,608	88,580	10,000
PHA932F0320 MF	32.00	2,800	4,500	>38≤48	35.80	9,680	1,093	26,574	3,000	40,818	4,608	88,580	10,000
PHA932F0320 MFC	32.00	4,000	4,500	≤32	50.75	9,680	1,093	26,574	3,000	40,818	4,608	88,580	10,000
PHA932F0320 MFC	32.00	4,000	4,500	>32≤38	52.54	9,680	1,093	26,574	3,000	40,818	4,608	88,580	10,000
PHA932F0320 MFC	32.00	4,000	4,500	>38≤48	51.66	9,680	1,093	26,574	3,000	40,818	4,608	88,580	10,000
PHA932F0400 MF	40.00	2,800	4,500	≤32	34.97	9,265	1,046	23,810	2,688	40,818	4,608	88,580	10,000
PHA932F0400 MF	40.00	2,800	4,500	>32≤38	34.76	9,265	1,046	23,810	2,688	40,818	4,608	88,580	10,000
PHA932F0400 MF	40.00	2,800	4,500	>38≤48	34.13	9,265	1,046	23,810	2,688	40,818	4,608	88,580	10,000
PHA932F0400 MFC	40.00	4,000	4,500	≤32	49.08	9,265	1,046	23,810	2,688	40,818	4,608	88,580	10,000
PHA932F0400 MFC	40.00	4,000	4,500	>32≤38	50.87	9,265	1,046	23,810	2,688	40,818	4,608	88,580	10,000
PHA932F0400 MFC	40.00	4,000	4,500	>38≤48	49.99	9,265	1,046	23,810	2,688	40,818	4,608	88,580	10,000
PHA932F0420 MF	42.00	2,800	4,500	≤32	37.19	9,637	1,088	26,574	3,000	39,861	4,500	79,722	9,000
PHA932F0420 MF	42.00	2,800	4,500	>32≤38	36.99	9,637	1,088	26,574	3,000	39,861	4,500	79,722	9,000
PHA932F0420 MF	42.00	2,800	4,500	>38≤48	36.35	9,637	1,088	26,574	3,000	39,861	4,500	79,722	9,000

Index of Symbols: MF — Motor adapter with FlexiAdapt® coupling; L — Large Input; C — ServoCool

See Page 86 for Options and Part Number Configuration.



"PHA" Series – Advanced ServoFit® Precision Planetary Gearhead Selection Data



P
H
A

Part Number (Gearhead + Input)	Exact Ratio i	Maximum Input Speed		Motor Shaft ØD ⁶ mm	Input ¹⁾ Inertia J ₁ kgcm ²	Torsional Stiffness per arcmin C ₂		Output Torque					
		Continuous RPM (n ₁)	Cyclic RPM (n ₁)			in.lbs.	Nm	Nominal ²⁾ M _{2N}		Acceleration M _{2B}		Peak ³⁾ M _{2PEAK}	
								in.lbs.	Nm	in.lbs.	Nm	in.lbs.	Nm
PHA932 with Motor Mounting Plate Continued													
PHA932F0420 MFC	42.00	4,000	4,500	≤32	51.31	9,637	1,088	26,574	3,000	39,861	4,500	79,722	9,000
PHA932F0420 MFC	42.00	4,000	4,500	>32≤38	53.09	9,637	1,088	26,574	3,000	39,861	4,500	79,722	9,000
PHA932F0420 MFC	42.00	4,000	4,500	>38≤48	52.21	9,637	1,088	26,574	3,000	39,861	4,500	79,722	9,000
PHA932F0480 MF	48.00	2,800	4,500	≤32	35.79	9,533	1,076	26,574	3,000	39,861	4,500	79,722	9,000
PHA932F0480 MF	48.00	2,800	4,500	>32≤38	35.58	9,533	1,076	26,574	3,000	39,861	4,500	79,722	9,000
PHA932F0480 MF	48.00	2,800	4,500	>38≤48	34.95	9,533	1,076	26,574	3,000	39,861	4,500	79,722	9,000
PHA932F0480 MFC	48.00	4,000	4,500	≤32	49.90	9,533	1,076	26,574	3,000	39,861	4,500	79,722	9,000
PHA932F0480 MFC	48.00	4,000	4,500	>32≤38	51.69	9,533	1,076	26,574	3,000	39,861	4,500	79,722	9,000
PHA932F0480 MFC	48.00	4,000	4,500	>38≤48	50.81	9,533	1,076	26,574	3,000	39,861	4,500	79,722	9,000
PHA932F0600 MF	60.00	2,800	4,500	≤32	34.42	9,349	1,055	26,574	3,000	39,861	4,500	79,722	9,000
PHA932F0600 MF	60.00	2,800	4,500	>32≤38	34.22	9,349	1,055	26,574	3,000	39,861	4,500	79,722	9,000
PHA932F0600 MF	60.00	2,800	4,500	>38≤48	33.58	9,349	1,055	26,574	3,000	39,861	4,500	79,722	9,000
PHA932F0600 MFC	60.00	4,000	4,500	≤32	48.54	9,349	1,055	26,574	3,000	39,861	4,500	79,722	9,000
PHA932F0600 MFC	60.00	4,000	4,500	>32≤38	50.32	9,349	1,055	26,574	3,000	39,861	4,500	79,722	9,000
PHA932F0600 MFC	60.00	4,000	4,500	>38≤48	49.44	9,349	1,055	26,574	3,000	39,861	4,500	79,722	9,000
PHVA933 with Motor Mounting Plate													
PHVA933F0610 MF	61.00	2,500	4,500	≤24	54.43	7,478	844	22,145	2,500	37,647	4,250	79,722	9,000
PHVA933F0610 MF	61.00	2,500	4,500	>24≤32	54.76	7,488	845	22,145	2,500	37,647	4,250	79,722	9,000
PHVA933F0610 MF	61.00	2,500	4,500	>32≤38	54.76	7,488	845	22,145	2,500	37,647	4,250	79,722	9,000
PHVA933F0610 MFC	61.00	3,200	4,500	>24≤32	58.96	7,488	845	22,145	2,500	37,647	4,250	79,722	9,000
PHVA933F0610 MFC	61.00	3,200	4,500	>32≤38	60.56	7,488	845	22,145	2,500	37,647	4,250	79,722	9,000
PHVA933F0610 MFL	61.00	2,500	4,500	>38≤48	73.56	7,508	848	22,145	2,500	37,647	4,250	79,722	9,000
PHVA933F0910 MF	91.00	2,500	4,500	≤24	50.61	7,403	836	22,145	2,500	37,647	4,250	79,722	9,000
PHVA933F0910 MF	91.00	2,500	4,500	>24≤32	50.61	7,403	836	22,145	2,500	37,647	4,250	79,722	9,000
PHVA933F0910 MF	91.00	2,500	4,500	>32≤38	50.61	7,403	836	22,145	2,500	37,647	4,250	79,722	9,000
PHVA933F0910 MFC	91.00	3,200	4,500	≤24	56.03	7,403	836	22,145	2,500	37,647	4,250	79,722	9,000
PHVA933F0910 MFC	91.00	3,200	4,500	>24≤32	54.82	7,403	836	22,145	2,500	37,647	4,250	79,722	9,000
PHVA933F0910 MFC	91.00	3,200	4,500	>32≤38	56.41	7,403	836	22,145	2,500	37,647	4,250	79,722	9,000
PHVA933F0910 MFL	91.00	2,500	4,500	>38≤48	69.77	7,415	837	22,145	2,500	37,647	4,250	79,722	9,000
PHVA933F1210 MF	121.0	2,500	4,500	≤24	49.23	7,119	804	22,145	2,500	37,647	4,250	79,722	9,000
PHVA933F1210 MF	121.0	2,500	4,500	>24≤32	49.23	7,119	804	22,145	2,500	37,647	4,250	79,722	9,000
PHVA933F1210 MF	121.0	2,500	4,500	>32≤38	49.23	7,119	804	22,145	2,500	37,647	4,250	79,722	9,000
PHVA933F1210 MFC	121.0	3,200	4,500	≤24	54.65	7,119	804	22,145	2,500	37,647	4,250	79,722	9,000
PHVA933F1210 MFC	121.0	3,200	4,500	>24≤32	53.43	7,119	804	22,145	2,500	37,647	4,250	79,722	9,000
PHVA933F1210 MFC	121.0	3,200	4,500	>32≤38	55.02	7,119	804	22,145	2,500	37,647	4,250	79,722	9,000
PHVA933F1210 MFL	121.0	2,500	4,500	>38≤48	68.39	7,125	804	22,145	2,500	37,647	4,250	79,722	9,000
PHA1032 with Motor Mounting Plate Continued Next Page													
PHA1032F0180 MF	18.00	1,800	3,000	≤32	78.84	14,490	1,636	40,818	4,608	49,175	5,551	61,468	6,939
PHA1032F0180 MF	18.00	1,800	3,000	>32≤38	78.62	14,664	1,656	40,818	4,608	61,226	6,912	89,266	10,077
PHA1032F0180 MF	18.00	1,800	3,000	>38≤48	77.98	14,664	1,656	40,818	4,608	61,226	6,912	98,290	11,096
PHA1032F0180 MFC	18.00	2,500	3,000	≤32	92.96	14,490	1,636	40,818	4,608	49,175	5,551	61,468	6,939
PHA1032F0180 MFC	18.00	2,500	3,000	>32≤38	94.72	14,664	1,655	40,818	4,608	61,226	6,912	89,266	10,077
PHA1032F0180 MFC	18.00	2,500	3,000	>38≤48	93.84	14,664	1,655	40,818	4,608	61,226	6,912	98,290	11,096
PHA1032F0240 MF	24.00	2,200	3,500	≤32	51.93	14,811	1,672	40,818	4,608	65,566	7,402	81,958	9,252
PHA1032F0240 MF	24.00	2,200	3,500	>32≤38	51.71	14,913	1,683	40,818	4,608	66,435	7,500	119,022	13,437
PHA1032F0240 MF	24.00	2,200	3,500	>38≤48	51.07	14,913	1,683	40,818	4,608	66,435	7,500	131,053	14,795
PHA1032F0240 MFC	24.00	2,700	3,500	≤32	66.05	14,811	1,672	40,818	4,608	65,566	7,402	81,958	9,252

¹⁾ Inertia based on maximum input. For lower inertia using smaller diameter input, contact STOBER.

²⁾ Based on input speed: n₁ = 2000 RPM

For torque at higher input speeds (M_{2Nx}) solve the formula, where n₁ = Actual Input Speed.
$$M_{2Nx} = \frac{M_{2N}}{\sqrt[3]{\frac{n_1}{2000}}}$$

³⁾ Maximum momentary torque for emergency stops or heavy shock load. Admissible stops per life of gearhead = 1,000 stops maximum.



"PHA" Series – Advanced ServoFit® Precision Planetary Gearhead Selection Data



Part Number (Gearhead + Input)	Exact Ratio i	Maximum Input Speed		Motor Shaft ØD ⁶ mm	Input ¹⁾ Inertia J ₁ kgcm ²	Torsional Stiffness per arcmin		Output Torque					
		Continuous RPM (n _i)	Cyclic RPM (n _c)			C ₂		Nominal ²⁾ M _{2N}		Acceleration M _{2B}		Peak ³⁾ M _{2PEAK}	
						in.lbs.	Nm	in.lbs.	Nm	in.lbs.	Nm	in.lbs.	Nm

PHA1032 with Motor Mounting Plate *Continued*

PHA1032F0240 MFC	24.00	2,700	3,500	>32≤38	67.81	14,913	1,683	40,818	4,608	66,435	7,500	119,022	13,437
PHA1032F0240 MFC	24.00	2,700	3,500	>38≤48	66.93	14,913	1,683	40,818	4,608	66,435	7,500	131,053	14,795
PHA1032F0300 MF	30.00	2,500	4,000	≤32	43.69	14,871	1,679	44,290	5,000	66,435	7,500	102,447	11,566
PHA1032F0300 MF	30.00	2,500	4,000	>32≤38	43.46	14,937	1,686	44,290	5,000	66,435	7,500	132,870	15,000
PHA1032F0300 MF	30.00	2,500	4,000	>38≤48	42.83	14,937	1,686	44,290	5,000	66,435	7,500	132,870	15,000
PHA1032F0300 MFC	30.00	3,200	4,000	≤32	57.80	14,871	1,679	44,290	5,000	66,435	7,500	102,447	11,566
PHA1032F0300 MFC	30.00	3,200	4,000	>32≤38	59.57	14,937	1,686	44,290	5,000	66,435	7,500	132,870	15,000
PHA1032F0300 MFC	30.00	3,200	4,000	>38≤48	58.69	14,937	1,686	44,290	5,000	66,435	7,500	132,870	15,000
PHA1032F0420 MF	42.00	2,800	4,500	≤32	37.77	14,754	1,666	44,290	5,000	66,435	7,500	132,870	15,000
PHA1032F0420 MF	42.00	2,800	4,500	>32≤38	37.57	14,754	1,666	44,290	5,000	66,435	7,500	132,870	15,000
PHA1032F0420 MF	42.00	2,800	4,500	>38≤48	36.93	14,754	1,666	44,290	5,000	66,435	7,500	132,870	15,000
PHA1032F0420 MFC	42.00	4,000	4,500	≤32	51.88	14,754	1,666	44,290	5,000	66,435	7,500	132,870	15,000
PHA1032F0420 MFC	42.00	4,000	4,500	>32≤38	53.67	14,754	1,666	44,290	5,000	66,435	7,500	132,870	15,000
PHA1032F0420 MFC	42.00	4,000	4,500	>38≤48	52.79	14,754	1,666	44,290	5,000	66,435	7,500	132,870	15,000
PHA1032F0480 MF	48.00	2,800	4,500	≤32	36.23	14,510	1,638	40,818	4,608	61,226	6,912	132,870	15,000
PHA1032F0480 MF	48.00	2,800	4,500	>32≤38	36.03	14,510	1,638	40,818	4,608	61,226	6,912	132,870	15,000
PHA1032F0480 MF	48.00	2,800	4,500	>38≤48	35.39	14,510	1,638	40,818	4,608	61,226	6,912	132,870	15,000
PHA1032F0480 MFC	48.00	4,000	4,500	≤32	50.34	14,510	1,638	40,818	4,608	61,226	6,912	132,870	15,000
PHA1032F0480 MFC	48.00	4,000	4,500	>32≤38	52.13	14,510	1,638	40,818	4,608	61,226	6,912	132,870	15,000
PHA1032F0480 MFC	48.00	4,000	4,500	>38≤48	51.25	14,510	1,638	40,818	4,608	61,226	6,912	132,870	15,000
PHA1032F0600 MF	60.00	2,800	4,500	≤32	34.71	14,090	1,591	35,715	4,032	61,226	6,912	132,870	15,000
PHA1032F0600 MF	60.00	2,800	4,500	>32≤38	34.50	14,090	1,591	35,715	4,032	61,226	6,912	132,870	15,000
PHA1032F0600 MF	60.00	2,800	4,500	>38≤48	33.87	14,090	1,591	35,715	4,032	61,226	6,912	132,870	15,000
PHA1032F0600 MFC	60.00	4,000	4,500	≤32	48.82	14,090	1,591	35,715	4,032	61,226	6,912	132,870	15,000
PHA1032F0600 MFC	60.00	4,000	4,500	>32≤38	50.61	14,090	1,591	35,715	4,032	61,226	6,912	132,870	15,000
PHA1032F0600 MFC	60.00	4,000	4,500	>38≤48	49.73	14,090	1,591	35,715	4,032	61,226	6,912	132,870	15,000

PHVA1033 with Motor Mounting Plate

PHVA1033F0610 MF	61.00	2,500	4,500	≤32	152.86	12,068	1,362	35,432	4,000	66,435	7,500	132,870	15,000
PHVA1033F0610 MF	61.00	2,500	4,500	>32≤38	152.66	12,078	1,364	35,432	4,000	66,435	7,500	132,870	15,000
PHVA1033F0610 MF	61.00	2,500	4,500	>38≤48	152.02	12,078	1,364	35,432	4,000	66,435	7,500	132,870	15,000
PHVA1033F0610 MFC	61.00	3,000	4,500	>32≤38	167.34	12,078	1,364	35,432	4,000	66,435	7,500	132,870	15,000
PHVA1033F0610 MFC	61.00	3,000	4,500	>38≤48	167.10	12,078	1,364	35,432	4,000	66,435	7,500	132,870	15,000
PHVA1033F0910 MF	91.00	2,500	4,500	≤32	127.47	11,858	1,339	35,432	4,000	66,435	7,500	132,870	15,000
PHVA1033F0910 MF	91.00	2,500	4,500	>32≤38	127.26	11,858	1,339	35,432	4,000	66,435	7,500	132,870	15,000
PHVA1033F0910 MF	91.00	2,500	4,500	>38≤48	126.62	11,858	1,339	35,432	4,000	66,435	7,500	132,870	15,000
PHVA1033F0910 MFC	91.00	3,000	4,500	≤32	139.95	11,858	1,339	35,432	4,000	66,435	7,500	132,870	15,000
PHVA1033F0910 MFC	91.00	3,000	4,500	>32≤38	141.94	11,858	1,339	35,432	4,000	66,435	7,500	132,870	15,000
PHVA1033F0910 MFC	91.00	3,000	4,500	>38≤48	141.70	11,858	1,339	35,432	4,000	66,435	7,500	132,870	15,000

Index of Symbols: MF — Motor adapter with FlexiAdapt® coupling; L — Large Input; C — ServoCool

See Page 86 for Options and Part Number Configuration.



"PHA" Series – Advanced ServoFit® Precision Planetary Gearhead Dimensional Data



Drawing for Units
PHA321 – PHVA1033

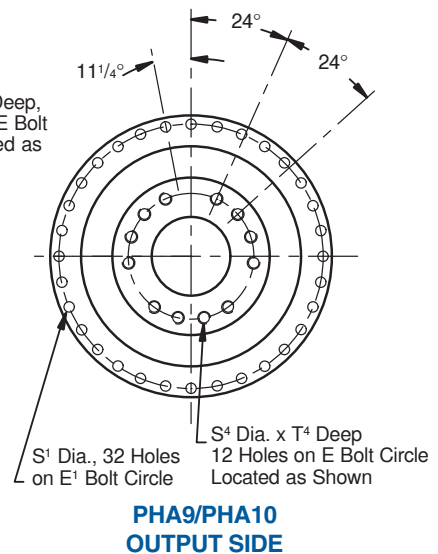
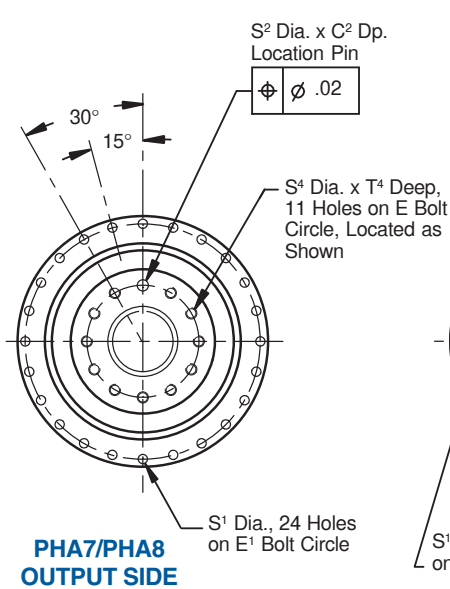
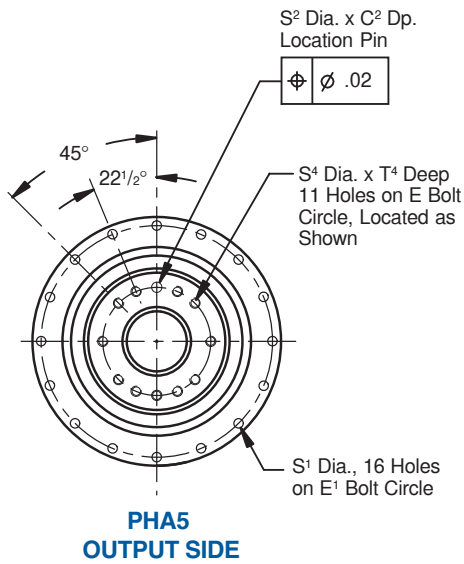
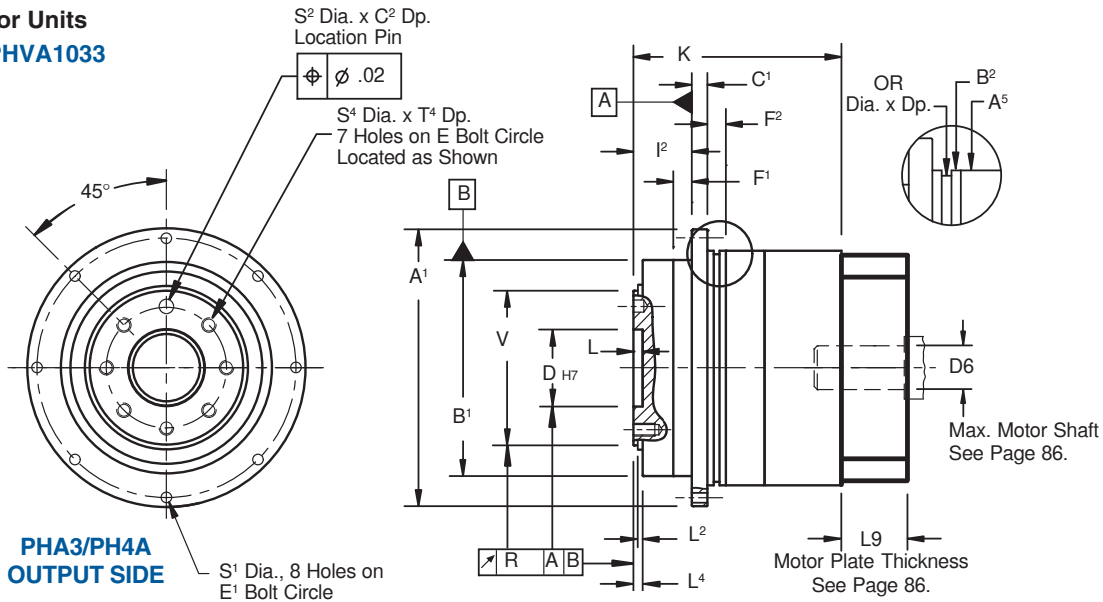

Table No. 1

"PHA" Series – Advanced Gearhead with Motor Plate – Dimensions (mm)

Unit	A ¹ h ₇	B ¹ h ₇	B ² h ₇	C ¹	C ²	D h ₇	E	E ¹	F ¹	F ²	l ²	L	L ²	L ⁴	OR
PHA321/PHA322	86 +.000/-0.035	64 +.000/-0.030	70 * +.000/-0.030	4	3	20 +.021/-0	31.5	79	7	8	19.5	4	3	3.5	65x2
PHA421/PHA422	118 +.000/-0.035	90 +.000/-0.035	95 +.000/-0.035	7	7	31.5 +.025/-0	50	109	10	10	30	6	6	6	90x3
PHA521/PHA522	145 +.000/-0.040	110 +.000/-0.035	120 * +.000/-0.035	8	7	40 +.025/-0	63	135	10	12	29	6	6	6	110x3
PHA721/PHA722	179 +.000/-0.040	140 +.000/-0.040	152 +.000/-0.040	10	7	50 +.025/-0	80	168	12	12	38	6	6	6	145x3
PHA821/PHA822	247 +.000/-0.046	200 +.000/-0.046	212 +.000/-0.046	12	10	80 +.030/-0	125	233	15	15	50	8	8	8	200x5
PHA932/PHVA933	300 —	255 +.000/-0.052	255 +.000/-0.052	18	—	90 +.035/-0	140	280	20	33	66	12	11	12	238x5
PHA1032/PHVA1033	330 —	285 +.000/-0.057	285 +.000/-0.052	20	—	95 +.035/-0	160	310	20	20	75	10	15	15	270x6

* Not applicable for PH322 and PH522.



"PHA" Series – Advanced ServoFit® Precision Planetary Gearhead Dimensional Data



Table No. 2 "PHA" Series – Dimensions (mm)

Unit	R	S ¹	S ²	H ⁷	S ⁴	T ⁴	V	h ⁷
PHA321/PHA322	.020	4.5	5	+0.012/-0.000	M5	7	40	+0.000/-0.025
PHA421/PHA422	.020	5.5	6	+0.012/-0.000	M6	11	63	+0.000/-0.030
PHA521/PHA522	.020	5.5	6	+0.012/-0.000	M6	11	80	+0.000/-0.030
PHA721/PHA722	.025	6.6	8	+0.015/-0.000	M8	14	100	+0.000/-0.035
PHA821/PHA822	.030	9	10	+0.015/-0.000	M10	18	160	+0.000/-0.040
PHA932/PHVA933	.030	13.5	—	—	M16	24	180	+0.000/-0.040
PHA1032/PHVA1033	.040	13.5	—	—	M20	30	200	+0.000/-0.046



Typical 2 Stage Configuration



Typical ServoCool

PHA

Table No. 3 "PHA" Series – Dimensions (mm)

Standard			ServoCool			Large Input		
Unit	A ⁵	K	Unit	A ⁵	K	Unit	A ⁵	K
PHA321	70	80.5	—	—	—	PHA321_L	95	84.5
PHA322	55	104	—	—	—	—	—	—
PHA421	95	99	PHA421_C	98	122.5	PHA421_L	120	117.5
PHA422	72	146.5	—	—	—	PHA422_L	100	150.5
PHA521	120	110	PHA521_C	115	138	PHA521_L	152	124
PHA522	98	159.5	PHA522_C	98	183	PHA522_L	115	171
PHA721	152	138	PHA721_C	145	168	PHA721_L	212	155
PHA722	115	190	PHA722_C	115	218	PHA722_L	145	204
PHA821	212	183	PHA821_C	190	231	—	—	—
PHA822	145	251	PHA822_C	145	281	PHA822_L	190	268
PHA932	190	349.5	PHA932_C	190	397.5	—	—	—
PHVA933	152	269.5	PHVA933_C	145	299.5	PHVA933_L	225	274
PHA1032	190	366	PHA1032_C	190	414	—	—	—
PHVA1033	212	307	PHVA1033_C	190	355	—	—	—

Part No. Example
PHA521F0050MF

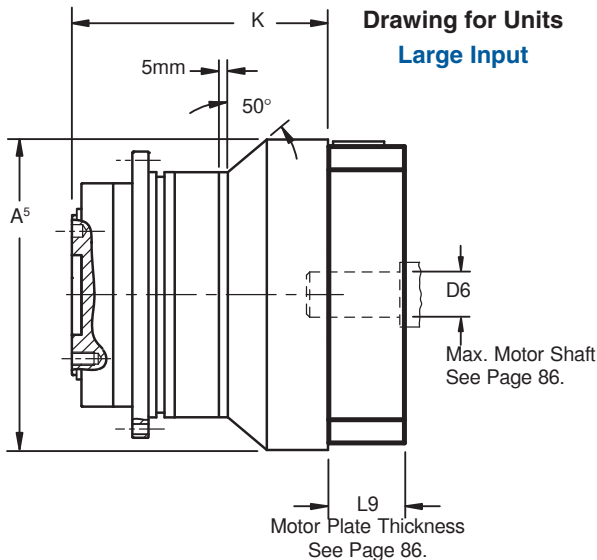

If a planetary gearhead is to be mounted from "B" side, specify when ordering. For proper mounting the paint must be eliminated and the tolerance held on that surface.



Side "B" mounting is not possible with the Large Input.

See Page 86 for Options and Part Number Configuration.

"PHKX" Series – Right Angle ServoFit® Precision Planetary Gearhead Performance Specifications



PHKX

Size			PH321 KX3	PH322 KX3	PH421 KX4	PH422 KX3	PH521 KX5	PH522 KX4	PH721 KX7	PH722 KX5	PH821 KX8	PH822 KX7	PH932 KX8	PH1032 KX8
Acceleration Torque Maximum	M _{2B}	in.lbs. Nm	558 63	576 65	1,071 121	1,105 130	2,708 306	2,832 320	5,753 650	6,195 700	14,160 1,600	17,700 2,000	40,818 4,608	66,435 7,500
Output Torque Nominal	M _{2N}	in.lbs. Nm	398 45		797 90		1,947 220		3,894 440		8,850 1,000	11,063 1,250	26,574 3,000	44,290 5,000
Input Speed Maximum	n _{1MAX}	Continuous Cyclic	3,500 6,000		3,000 4,500	3,500 6,000	3,000 4,500		2,100 3,500	3,000 4,000	1,300 3,000	2,100 3,500	1,300 3,000	1,300 3,000
Torsional Backlash	Δφ	arcmin	≤6		≤5.5	≤3.5	≤5.5	≤3.5	≤5	≤3.5	≤5	≤3.5	≤4	≤3.5
Torsional Stiffness Maximum	C ₂	in.lbs./arcmin Nm/arcmin	69 7.8	88 10	168 19	230 26	416 47	575 65	1,053 119	1,239 140	2,505 283	3,407 385	9,301 1,051	14,062 1,589
Axial Load Maximum	F _{2AMAX}	lbs. N	371 1,650		484 2,150		934 4,150		1,384 6,150		2,261 10,050		7,425 33,000	11,250 50,000
Tilting Moment Maximum	M _{2K}	in.lbs. Nm	885 100		2,301 260		3,894 440		2,593 1,500		30,975 3,500		57,525 6,500	66,375 7,500
Weight	m	pounds kg	8 3.5	9 4.0	12 5.5	14 6.3	28 12.9	24 10.9	52 23.5	46 20.9	124 56	112 51	203 92.0	237 107.4
Noise Level	L _{PA}	dB(A)	≤70		≤70	≤70	≤72	≤70	≤72		≤74	≤72	≤74	≤74
Efficiency at Nominal Torque	η	%	≥93 - 96											
Balance Quality	Q 2.5 (Quality Class - 2.5 millimeters per second)													
Lubrication	Synthetic Oil (ISO VG 150)													
Mounting Position	See Page105.													
Ambient Temperature	0°C to +40°C (104° F) Other temperatures, contact STOBER Drives.													
Finish	Black (RAL 9005)													
Lifetime	L _h	hours	L _h > 10,000 hours if M _{2K} /M _{2A} < 1.25 and > 1.00 L _h > 20,000 hours if M _{2K} /M _{2A} > 1.25 and < 1.50 L _h > 30,000 hours if M _{2K} /M _{2A} > 1.5											
Warranty	5 Year Limited (2 Years on normal wear items: bearings, seals, etc.)													

1) Ratings based on input speed (n₁) of 2000 RPM.

For torque at higher input speeds (M_{2NX}) solve the formula, where n₁ = Actual Input Speed.

$$M_{2NX} = \frac{M_{2N}}{\sqrt[3]{\frac{n_1}{2000}}}$$

2) Tested at 1.5% of nominal torque and recorded on the output side of the gearhead.

3) Rating based on output speed (n₂) of 100 RPM. For values at other speeds see Page 105.

4) Measurement at one (1) meter distance with input speed (n₁) of 3000 RPM.

5) M_{2A} equals actual tilting moment of the application. See Page 105 for load values.

WARNING: In order to insure that the specified torque ratings are attained, it is essential to attach the gear units to the machine with a grade 12.9 fastener.

Refer to Page 302 for ServoFit Precision Planetary Gearhead Selection Procedure.



"PHKX" Series – Right Angle ServoFit® Precision Planetary Gearhead Features

The "PHKX" Series combines the "PH" Series ServoFit Precision Planetary Gearheads with a right angle to provide a configuration that is a smooth, precise, and reliable drive with the benefit of direct mounting to many types of equipment without a coupling. All units are lubricated for life with synthetic oil and sealed to IP65 standards to prevent lubricant contamination for long life.

Some features are:

- High Axial Load Capacity
- Superior Torsional Stiffness
- 5-300:1 Ratio Range
- Wide Selection of IEC, NEMA, or Customized Motor Wide Plates
- Lowest Backlash
- Advanced Helical Gear Technology
- 5 Year Limited Warranty (2 Year on bearings, seals, etc.)

PHKX

Highly efficient spiral bevel gearsets provide quiet operation and excellent torque carrying capacity.

Oversized tapered roller bearings and shafts for high radial load capacity and superior torsional stiffness

Gears are case hardened to 61 Rockwell "C" and ground for maximum efficiency

HeliCamber® gear technology provides minimum wear, low backlash, and low noise

Ring gear machined integral to the housing — not welded or pressed in — provides greater concentricity and more precise alignment

Blind pilot hole

Single piece steel housing

FKM double-lip radial oil seals for continuous duty applications and very good chemical resistance.

The output flange dimensions are ISO 9409 and allow easy mounting to rotary or indexing tables, pinions, timing belt pulleys, transmission shafting, etc., without using a coupling.

Motor plate can easily be changed to fit your choice of motors

The integrated motor coupling is designed to allow thermal expansion of the motor shaft—ensuring long motor life by preventing thrust load on the motor bearings.

Adapter bushings to fit all motor shafts — no key required

Motor plate pilot toleranced to fit your motor for precise concentricity

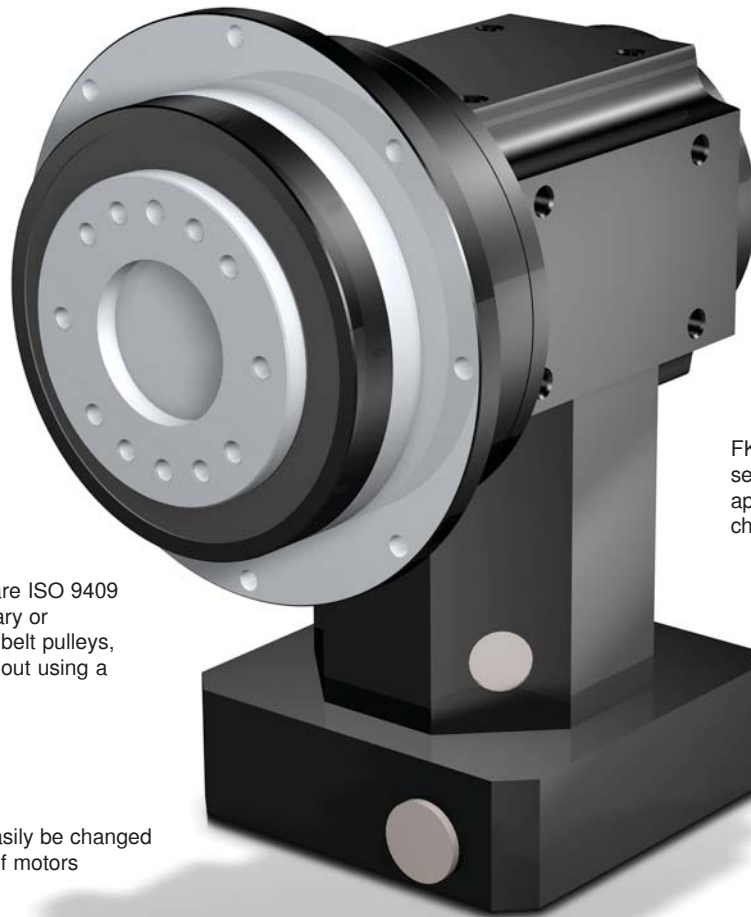

"PHKX" Series – Right Angle ServoFit® Precision Planetary Gearhead



Part No. Explanation

PH 4 2 1 F 0050 KX401VF 0020 MF

Series	Unit No.	Generation	No. of Stages	Output Flange	Ratio of PH	Right Angle	Ratio of Right Angle	Input
Series	PH	ServoFit Precision Planetary Gearhead						
Size	4	3, 4, 5, 6, 7, 8, 9, 10						
Generation	2	Generation No.						
No. of Stages	1	1 = 1 Stage, 2 = 2 Stage)						
Housing Style	F	Standard Output Flange Mounting						
Ratio	0050	Approximate: 0050 = 5.00:1 (range of 4:1 up to 100:1)						
Right Angle	KX401VF	Right Angle Unit, Size 4, 1 Stage, with Shaft (V) and Flange (F)						
Ratio	0020	Approximate: 0020 = 2.00:1 (range of 1:1 up to 3:1)						
Motor Adapter	MF	FlexiAdapt® Motor Adapter (Motor information must be specified.)						

PHKX

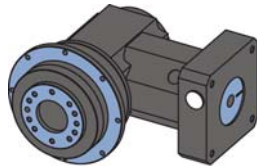

Motor Mounting Specifications

STOBER ServoFit Gearheads will fit the motor of your choice by assembling the correct motor mounting plate between the motor and the gearhead. **When ordering a gearhead, specify the motor manufacturer and part number, provide the motor drawing with dimensions, or specify the motor mounting dimensions.** The motor plate thickness (L^9) will be determined by the motor shaft length. The minimum motor plate thickness is shown below. For a precise dimension on a specific motor, contact STOBER Technical Support.

The following dimensions are required to provide the correct motor mounting plate:

1. D^6 Motor Shaft Diameter (If an adapter bushing is required it will be supplied with the motor plate.)
2. D^7 Pilot Diameter
3. D^8 Bolt Circle Diameter
4. D^9 Bolt Diameter
5. L^{11} Motor Shaft Length
6. L^{12} Pilot Length
7. L^{14} Square Flange (Optional — motor plate will typically be made to match this dimension.)

Table No. 1

Motor Plate Dims.	Planetary Size				
	PH321KX3	PH421KX4	PH521KX5	PH721KX7	PH821KX8
D^6 Max.	19	24	32	38	48
L^9 Min.	18	21	24	25	33

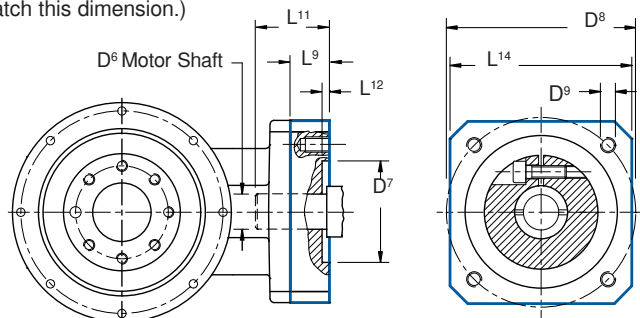



"PHKX" Series – Right Angle ServoFit® Precision Planetary Gearhead

Mounting Position

Any Horizontal Mounting – EL1, EL2, EL5, and EL6
 Vertical Mounting Position – EL3 and EL4 – MUST BE SPECIFIED

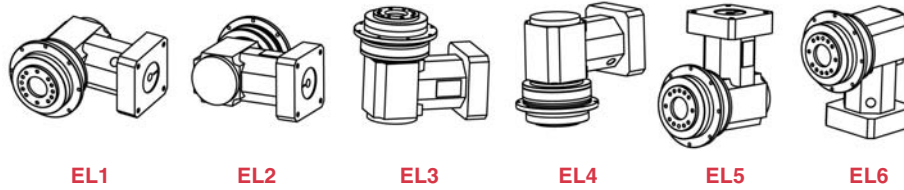

Direction of Rotation

PH321KX3 – PH521KX5
 PH322KX3 – PH522KX4

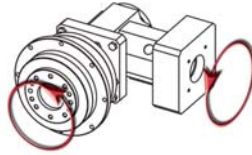

PH721KX7 – PH821KX8
 PH722KX5 – PH1012KX8



Permissible Output Load and Tilting Moments

The permissible load and tilting moment values are based on an output speed of 100 RPM. For higher speeds the following applies, where n_2 is the desired speed:

$$F_{2AX} = \frac{F_{2A}}{\sqrt[3]{\frac{n_2}{100}}} \quad M_{2KX} = \frac{M_{2K}}{\sqrt[3]{\frac{n_2}{100}}}$$

The application input tilting moment should be determined by the following formula:

$$M_{2A} = \frac{F_{2a} \cdot y_2 + F_{2rb} \cdot (X_2 + Z_2)}{1000} \leq M_{2KB}$$

$$M_{2Ka} = \sqrt[3]{\frac{\Omega_{2b1} \cdot t_{b1} \cdot M_{2kb1}^3 + \dots + \Omega_{2bn} \cdot t_{bn} \cdot M_{2kbn}^3}{\Omega_{2b1} \cdot t_{b1} + \dots + \Omega_{2bn} \cdot t_{bn}}} \leq M_{2K}$$

$$F_{2r} = \sqrt[3]{\frac{\Omega_{2b1} \cdot t_{b1} \cdot F_{2rb1}^3 + \dots + \Omega_{2bn} \cdot t_{bn} \cdot F_{2rbn}^3}{\Omega_{2b1} \cdot t_{b1} + \dots + \Omega_{2bn} \cdot t_{bn}}} \leq F_{2R}$$

- where:
- F_{2a} Axial Load at Output Shaft
 - F_{2A} Permissible Axial Load
 - F_{2r} Radial Load at Output Shaft
 - F_{2R} Permissible Radial Load
 - F_{2RB} Acceleration Permissible Radial Load
 - M_{2K} Rated Tilting Torque
 - M_{2Ka} Equivalent Tilting Load
 - M_{2KB} Acceleration Tilting Torque
 - Z_2 Distance Factor

The hours of life (L_h) of the unit can be determined by the following formula:

bearing life for duty cycle $\leq 40\%$
 $L_h > 10,000$ hours if $M_{2K}/M_{2A} < 1.25$ and > 1
 $L_h > 20,000$ hours if $M_{2K}/M_{2A} > 1.25$ and > 1.5
 $L_h > 30,000$ hours if $M_{2K}/M_{2A} < 1.5$

bearing life for duty cycle $\geq 40\%$
 $L_{hA} = L_h \left(\frac{40\%}{\text{Duty Cycle}} \right)$

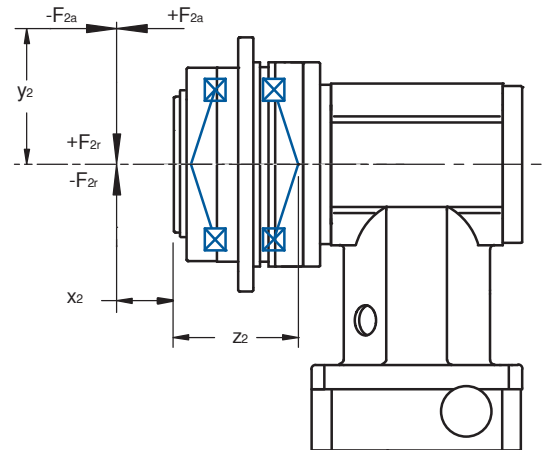

Table No. 2 "PH" Series – Permissible Output Load and Tilting Moments

Unit No.	Z_2		F_{2AMAX}		F_{2R}		F_{2RB}		M_{2K}		M_{2KB}		C_{2K}	
	mm	inches	N	lbs.	N	lbs.	N	lbs.	Nm	in.lbs.	Nm	in.lbs.	Nm/arcmin	In.lbs/arcmin
PH3KX	62	2.44	1,650	371	1,613	363	1,613	363	100	885	100	885	53	469
PH4KX	84	3.31	2,150	484	3,095	696	3,571	803	260	2,124	300	2,655	160	1,416
PH5KX	97	3.82	4,150	934	4,536	1,021	4,897	1,102	440	3,717	475	4,204	380	3,363
PH7KX	88	3.46	6,150	1,384	17,045	3,835	17,045	3,835	1,500	13,275	1,500	13,275	500	4,425
PH8KX	126	4.96	10,050	2,261	27,778	6,250	27,778	6,250	3,500	30,975	3,500	30,975	1,550	13,718
PH9KX	155	6.10	33,000	7,425	48,387	10,887	70,968	15,938	7,500	66,375	11,000	97,350	7,500	66,375
PH10KX	171	6.73	50,000	11,250	51,462	11,579	73,099	16,447	8,800	77,880	12,500	110,625	9,500	84,075

During EMERGENCY OFF operation (maximum stops per gearhead = 1000) the permissible values in the table for F_{2A} , F_{2R} , and M_{2K} can be multiplied by a factor of 2.



"PHKX" Series – Right Angle ServoFit® Precision Planetary Gearhead Selection Data



PHKX

Part Number (Gearhead + Input)	Exact Ratio i	Max. Input RPM (n ₁)			Max. Motor Shaft øD ⁶ mm	Input Inertia J ₁ kgcm ²	Torsional Stiffness per arcmin C ₂		Output Torque							
		Continuous		Cyclic			in.lbs.	Nm	Nominal ¹⁾		Acceleration		Peak ²⁾			
		Mounting Position							in.lbs.	Nm	in.lbs.	Nm	in.lbs.	Nm	in.lbs.	Nm
		EL 1,2,5,6	EL 3,4	All												
PH321_KX3 with Motor Mounting Plate																
PH321F0050 KX301VF0010 MF	5.000	3,000	2,500	4,000	19	1.08	56.5	6.4	399	45	553	62	935	106		
PH321F0070 KX301VF0010 MF	7.000	3,000	2,500	4,000	19	1.04	69.3	7.8	399	45	531	60	1,152	130		
PH321F0050 KX301VF0020 MF	10.00	3,500	3,000	5,000	19	0.82	56.5	6.4	399	45	553	62	1,063	120		
PH321F0070 KX301VF0020 MF	14.00	3,500	3,000	5,000	19	0.81	69.3	7.8	399	45	531	60	1,152	130		
PH321F0050 KX301VF0030 MF	15.00	3,500	3,500	6,000	19	0.75	56.5	6.4	399	45	553	62	1,063	120		
PH321F0100 KX301VF0020 MF	20.00	3,500	3,000	5,000	19	0.81	67.6	7.6	266	30	443	50	886	100		
PH321F0070 KX301VF0030 MF	21.00	3,500	3,500	6,000	19	0.75	69.3	7.8	399	45	531	60	1,152	130		
PH321F0100 KX301VF0030 MF	30.00	3,500	3,500	6,000	19	0.75	67.6	7.6	266	30	443	50	886	100		
PH322_KX3 with Motor Mounting Plate																
PH322F0350 KX301VF0010 MF	35.00	3,000	2,500	4,000	19	1.02	87.9	9.9	399	45	576	65	1,152	130		
PH322F0200 KX301VF0020 MF	40.00	3,500	3,000	5,000	19	0.81	86.0	9.7	399	45	576	65	1,152	130		
PH322F0250 KX301VF0020 MF	50.00	3,500	3,000	5,000	19	0.81	87.6	9.9	399	45	576	65	1,152	130		
PH322F0280 KX301VF0020 MF	56.00	3,500	3,000	5,000	19	0.81	88.4	10.0	399	45	531	60	1,152	130		
PH322F0200 KX301VF0030 MF	60.00	3,500	3,500	6,000	19	0.75	86.0	9.7	399	45	576	65	1,152	130		
PH322F0350 KX301VF0020 MF	70.00	3,500	3,000	5,000	19	0.81	87.9	9.9	399	45	576	65	1,152	130		
PH322F0250 KX301VF0030 MF	75.00	3,500	3,500	6,000	19	0.75	87.6	9.9	399	45	576	65	1,152	130		
PH322F0400 KX301VF0020 MF	80.00	3,500	3,000	5,000	19	0.81	75.3	8.5	266	30	443	50	886	100		
PH322F0280 KX301VF0030 MF	84.00	3,500	3,500	6,000	19	0.75	88.4	10.0	399	45	531	60	1,152	130		
PH322F0500 KX301VF0020 MF	100.0	3,500	3,000	5,000	19	0.80	86.2	9.7	399	45	576	65	1,152	130		
PH322F0350 KX301VF0030 MF	105.0	3,500	3,500	6,000	19	0.75	87.9	9.9	399	45	576	65	1,152	130		
PH322F0400 KX301VF0030 MF	120.0	3,500	3,500	6,000	19	0.75	75.3	8.5	266	30	443	50	886	100		
PH322F0700 KX301VF0020 MF	140.0	3,500	3,000	5,000	19	0.80	88.5	10.0	399	45	531	60	1,152	130		
PH322F0500 KX301VF0030 MF	150.0	3,500	3,500	6,000	19	0.75	86.2	9.7	399	45	576	65	1,152	130		
PH322F1000 KX301VF0020 MF	200.0	3,500	3,000	5,000	19	0.80	75.4	8.5	266	30	443	50	886	100		
PH322F0700 KX301VF0030 MF	210.0	3,500	3,500	6,000	19	0.75	88.5	10.0	399	45	531	60	1,152	130		
PH322F1000 KX301VF0030 MF	300.0	3,500	3,500	6,000	19	0.75	75.4	8.5	266	30	443	50	886	100		

¹⁾ Based on input speed: n₁ = 2000 RPM

For torque at higher input speeds (M_{2NX}) solve the formula, where n₁ = Actual Input Speed.
$$M_{2NX} = \frac{M_{2N}}{\sqrt[3]{\frac{n_1}{2000}}}$$

²⁾ Maximum momentary torque for emergency stops or heavy shock load. Admissible stops per life of gearhead = 1,000 stops maximum.



"PHKX" Series – Right Angle ServoFit® Precision Planetary Gearhead Selection Data



Part Number (Gearhead + Input)	Exact Ratio i	Max. Input RPM (n ₁)			Max. Motor Shaft øD ⁶ mm	Input Inertia J ₁ kgcm ²	Torsional Stiffness per arcmin C ₂		Output Torque							
		Continuous		Cyclic			in.lbs.	Nm	Nominal ¹⁾		Acceleration		Peak ²⁾			
		Mounting Position							in.lbs.	Nm	in.lbs.	Nm	in.lbs.	Nm	in.lbs.	Nm
		EL 1,2,5,6	EL 3,4	All												
PH421_KX4 with Motor Mounting Plate																
PH421F0040 KX401VF0010 MF	4.00	2,500	2,000	3,500	24	2.84	100.5	11.3	680	77	850	96	1,701	192		
PH421F0050 KX401VF0010 MF	5.00	2,500	2,000	3,500	24	2.66	132.2	14.9	753	85	1,063	120	2,126	240		
PH421F0070 KX401VF0010 MF	7.00	2,500	2,000	3,500	24	2.51	168.2	19.0	753	85	974	110	2,126	240		
PH421F0040 KX401VF0020 MF	8.00	2,500	2,500	4,000	24	1.74	100.5	11.3	680	77	850	96	1,701	192		
PH421F0050 KX401VF0020 MF	10.00	2,500	2,500	4,000	24	1.70	132.2	14.9	797	90	1,063	120	2,126	240		
PH421F0070 KX401VF0020 MF	14.00	2,500	2,500	4,000	24	1.66	168.2	19.0	797	90	974	110	2,126	240		
PH421F0050 KX401VF0030 MF	15.00	3,000	3,000	4,500	24	1.47	132.2	14.9	797	90	1,063	120	2,126	240		
PH421F0100 KX401VF0020 MF	20.00	2,500	2,500	4,000	24	1.64	153.7	17.4	531	60	886	100	1,772	200		
PH421F0070 KX401VF0030 MF	21.00	3,000	3,000	4,500	24	1.45	168.2	19.0	797	90	974	110	2,126	240		
PH421F0100 KX401VF0030 MF	30.00	3,000	3,000	4,500	24	1.44	153.7	17.4	531	60	886	100	1,772	200		
PH422_KX3 with Motor Mounting Plate																
PH422F0350 KX301VF0010 MF	35.00	3,000	2,500	4,000	19	1.05	234.6	26.5	797	90	1,152	130	2,126	240		
PH422F0200 KX301VF0020 MF	40.00	3,500	3,000	5,000	19	0.84	223.8	25.3	797	90	1,152	130	2,126	240		
PH422F0160 KX301VF0030 MF	48.00	3,500	3,500	6,000	19	0.76	195.8	22.1	797	90	1,152	130	2,126	240		
PH422F0250 KX301VF0020 MF	50.00	3,500	3,000	5,000	19	0.82	232.7	26.3	797	90	1,152	130	2,126	240		
PH422F0280 KX301VF0020 MF	56.00	3,500	3,000	5,000	19	0.81	208.9	23.6	797	90	1,152	130	2,126	240		
PH422F0200 KX301VF0030 MF	60.00	3,500	3,500	6,000	19	0.76	223.8	25.3	797	90	1,152	130	2,126	240		
PH422F0350 KX301VF0020 MF	70.00	3,500	3,000	5,000	19	0.81	234.6	26.5	797	90	1,152	130	2,126	240		
PH422F0250 KX301VF0030 MF	75.00	3,500	3,500	6,000	19	0.76	232.7	26.3	797	90	1,152	130	2,126	240		
PH422F0400 KX301VF0020 MF	80.00	3,500	3,000	5,000	19	0.81	208.3	23.5	797	90	1,152	130	2,126	240		
PH422F0280 KX301VF0030 MF	84.00	3,500	3,500	6,000	19	0.75	208.9	23.6	797	90	1,152	130	2,126	240		
PH422F0500 KX301VF0020 MF	100.00	3,500	3,000	5,000	19	0.81	234.2	26.4	797	90	1,152	130	2,126	240		
PH422F0350 KX301VF0030 MF	105.00	3,500	3,500	6,000	19	0.75	234.6	26.5	797	90	1,152	130	2,126	240		
PH422F0400 KX301VF0030 MF	120.00	3,500	3,500	6,000	19	0.75	208.3	23.5	797	90	1,152	130	2,126	240		
PH422F0700 KX301VF0020 MF	140.00	3,500	3,000	5,000	19	0.81	234.5	26.5	797	90	974	110	2,126	240		
PH422F0500 KX301VF0030 MF	150.00	3,500	3,500	6,000	19	0.75	234.2	26.4	797	90	1,152	130	2,126	240		
PH422F1000 KX301VF0020 MF	200.00	3,500	3,000	5,000	19	0.81	176.0	19.9	531	60	886	100	1,772	200		
PH422F0700 KX301VF0030 MF	210.00	3,500	3,500	6,000	19	0.75	234.5	26.5	797	90	974	110	2,126	240		
PH422F1000 KX301VF0030 MF	300.00	3,500	3,500	6,000	19	0.75	176.0	19.9	531	60	886	100	1,772	200		

PHKX

Index of Symbols: MF — Motor adapter with FlexiAdapt® coupling; L — Large Input; C — ServoCool

See Page 104 for Options and Part Number Configuration.



"PHKX" Series – Right Angle ServoFit® Precision Planetary Gearhead Selection Data



PHKX

Part Number (Gearhead + Input)	Exact Ratio i	Max. Input RPM (n ₁)			Max. Motor Shaft øD ⁶ mm	Input Inertia J ₁ kgcm ²	Torsional Stiffness per arcmin C ₂		Output Torque					
		Continuous		Cyclic			in.lbs.	Nm	Nominal ¹⁾		Acceleration		Peak ²⁾	
		Mounting Position							in.lbs.	Nm	M _{2N}		M _{2B}	
		EL 1,2,5,6	EL 3,4	All			in.lbs.	Nm			in.lbs.	Nm	in.lbs.	Nm
PH521_KX5 with Motor Mounting Plate														
PH521F0040 KX501VF0010 MF	4.000	2,500	2,000	3,000	32	7.62	244.4	27.6	1,701	192	2,143	242	4,252	480
PH521F0050 KX501VF0010 MF	5.000	2,500	2,000	3,000	32	8.44	323.1	36.5	1,860	210	2,679	302	5,315	600
PH521F0070 KX501VF0010 MF	7.000	2,500	2,000	3,000	32	7.97	412.2	46.5	1,860	210	2,392	270	5,315	600
PH521F0040 KX501VF0020 MF	8.000	2,500	2,500	3,500	32	5.31	244.4	27.6	1,701	192	2,143	242	4,252	480
PH521F0050 KX501VF0020 MF	10.000	2,500	2,500	3,500	32	5.52	323.1	36.5	1,949	220	2,679	302	5,315	600
PH521F0070 KX501VF0020 MF	14.000	2,500	2,500	3,500	32	5.40	412.2	46.5	1,860	210	2,392	270	5,315	600
PH521F0050 KX501VF0030 MF	15.000	3,000	3,000	4,000	32	4.88	323.1	36.5	1,949	220	2,679	302	5,315	600
PH521F0100 KX501VF0020 MF	20.000	2,500	2,500	3,500	32	5.33	396.4	44.7	1,240	140	2,215	250	4,429	500
PH521F0070 KX501VF0030 MF	21.000	3,000	3,000	4,000	32	4.83	412.2	46.5	1,860	210	2,392	270	5,315	600
PH521F0100 KX501VF0030 MF	30.000	3,000	3,000	4,000	32	4.80	396.4	44.7	1,240	140	2,215	250	4,429	500
PH522_KX4 with Motor Mounting Plate														
PH522F0350 KX401VF0010 MF	35.000	2,500	2,000	3,500	24	2.46	570.4	64.4	1,949	220	2,835	320	5,315	600
PH522F0200 KX401VF0020 MF	40.000	2,500	2,500	4,000	24	1.71	534.1	60.3	1,949	220	2,835	320	5,315	600
PH522F0160 KX401VF0030 MF	48.000	3,000	3,000	4,500	24	1.46	458.5	51.8	1,860	210	2,835	320	4,915	555
PH522F0250 KX401VF0020 MF	50.000	2,500	2,500	4,000	24	1.68	561.6	63.4	1,949	220	2,835	320	5,315	600
PH522F0280 KX401VF0020 MF	56.000	2,500	2,500	4,000	24	1.64	501.4	56.6	1,860	210	2,835	320	4,915	555
PH522F0200 KX401VF0030 MF	60.000	3,000	3,000	4,500	24	1.47	534.1	60.3	1,949	220	2,835	320	5,315	600
PH522F0350 KX401VF0020 MF	70.000	2,500	2,500	4,000	24	1.65	570.4	64.4	1,949	220	2,835	320	5,315	600
PH522F0250 KX401VF0030 MF	75.000	3,000	3,000	4,500	24	1.46	561.6	63.4	1,949	220	2,835	320	5,315	600
PH522F0400 KX401VF0020 MF	80.000	2,500	2,500	4,000	24	1.63	498.4	56.3	1,860	210	2,835	320	4,915	555
PH522F0280 KX401VF0030 MF	84.000	3,000	3,000	4,500	24	1.44	501.4	56.6	1,860	210	2,835	320	4,915	555
PH522F0500 KX401VF0020 MF	100.000	2,500	2,500	4,000	24	1.64	567.9	64.1	1,949	220	2,835	320	5,315	600
PH522F0350 KX401VF0030 MF	105.000	3,000	3,000	4,500	24	1.44	570.4	64.4	1,949	220	2,835	320	5,315	600
PH522F0400 KX401VF0030 MF	120.000	3,000	3,000	4,500	24	1.44	498.4	56.3	1,860	210	2,835	320	4,915	555
PH522F0700 KX401VF0020 MF	140.000	2,500	2,500	4,000	24	1.63	573.0	64.7	1,860	210	2,392	270	5,315	600
PH522F0500 KX401VF0030 MF	150.000	3,000	3,000	4,500	24	1.44	567.9	64.1	1,949	220	2,835	320	5,315	600
PH522F1000 KX401VF0020 MF	200.000	2,500	2,500	4,000	24	1.63	456.8	51.6	1,240	140	2,215	250	4,429	500
PH522F0700 KX401VF0030 MF	210.000	3,000	3,000	4,500	24	1.44	573.0	64.7	1,860	210	2,392	270	5,315	600
PH522F1000 KX401VF0030 MF	300.000	3,000	3,000	4,500	24	1.44	456.8	51.6	1,240	140	2,215	250	4,429	500

¹⁾ Based on input speed: n₁ = 2000 RPM

For torque at higher input speeds (M_{2NX}) solve the formula, where n₁ = Actual Input Speed.
$$M_{2NX} = \frac{M_{2N}}{\sqrt[3]{\frac{n_1}{2000}}}$$

²⁾ Maximum momentary torque for emergency stops or heavy shock load. Admissible stops per life of gearhead = 1,000 stops maximum.



"PHKX" Series – Right Angle ServoFit® Precision Planetary Gearhead Selection Data



Part Number (Gearhead + Input)	Exact Ratio i	Max. Input RPM (n ₁)			Max. Motor Shaft øD ⁶ mm	Input Inertia J ₁ kgcm ²	Torsional Stiffness per arcmin C ₂		Output Torque							
		Continuous		Cyclic			in.lbs.	Nm	Nominal ¹⁾		Acceleration		Peak ²⁾			
		Mounting Position							in.lbs.	Nm	in.lbs.	Nm	in.lbs.	Nm	in.lbs.	Nm
		EL 1,2,5,6	EL 3,4	All												
PH721_KX7 with Motor Mounting Plate																
PH721F0040 KX701VF0010 MF	4.000	1,800	1,600	2,250	38	29.54	739.1	83.4	3,401	384	4,252	480	7,483	845		
PH721F0050 KX701VF0010 MF	5.000	1,800	1,600	2,250	38	27.70	918.4	103.7	3,898	440	5,315	600	9,354	1,056		
PH721F0070 KX701VF0010 MF	7.000	1,800	1,600	2,250	38	26.28	1054.7	119.1	3,898	440	5,758	650	11,127	1,256		
PH721F0040 KX701VF0020 MF	8.000	1,800	1,800	3,000	38	15.88	739.1	83.4	3,401	384	4,252	480	8,504	960		
PH721F0050 KX701VF0020 MF	10.00	1,800	1,800	3,000	38	15.42	918.4	103.7	3,898	440	5,315	600	10,630	1,200		
PH721F0070 KX701VF0020 MF	14.00	1,800	1,800	3,000	38	15.07	1054.7	119.1	3,898	440	5,758	650	11,127	1,256		
PH721F0050 KX701VF0030 MF	15.00	2,100	2,100	3,500	38	12.74	918.4	103.7	3,898	440	5,315	600	10,630	1,200		
PH721F0100 KX701VF0020 MF	20.00	1,800	1,800	3,000	38	14.89	922.7	104.2	2,657	300	4,429	500	8,858	1,000		
PH721F0070 KX701VF0030 MF	21.00	2,100	2,100	3,500	38	12.58	1054.7	119.1	3,898	440	5,758	650	11,127	1,256		
PH721F0100 KX701VF0030 MF	30.00	2,100	2,100	3,500	38	12.50	922.7	104.2	2,657	300	4,429	500	8,858	1,000		
PH722_KX5 with Motor Mounting Plate																
PH722F0350 KX501VF0010 MF	35.00	2,500	2,000	3,000	32	7.82	1229.7	138.8	3,898	440	6,201	700	12,401	1,400		
PH722F0200 KX501VF0020 MF	40.00	2,500	2,500	3,500	32	5.55	1147.0	129.5	3,898	440	6,201	700	12,401	1,400		
PH722F0160 KX501VF0030 MF	48.00	3,000	3,000	4,000	32	4.91	986.4	111.4	3,898	440	6,201	700	12,235	1,381		
PH722F0250 KX501VF0020 MF	50.00	2,500	2,500	3,500	32	5.44	1199.0	135.4	3,898	440	6,201	700	12,401	1,400		
PH722F0280 KX501VF0020 MF	56.00	2,500	2,500	3,500	32	5.37	1084.3	122.4	3,898	440	6,201	700	12,235	1,381		
PH722F0200 KX501VF0030 MF	60.00	3,000	3,000	4,000	32	4.90	1147.0	129.5	3,898	440	6,201	700	12,401	1,400		
PH722F0350 KX501VF0020 MF	70.00	2,500	2,500	3,500	32	5.36	1229.7	138.8	3,898	440	6,201	700	12,401	1,400		
PH722F0250 KX501VF0030 MF	75.00	3,000	3,000	4,000	32	4.85	1199.0	135.4	3,898	440	6,201	700	12,401	1,400		
PH722F0400 KX501VF0020 MF	80.00	2,500	2,500	3,500	32	5.32	1084.8	122.5	3,898	440	6,201	700	12,235	1,381		
PH722F0280 KX501VF0030 MF	84.00	3,000	3,000	4,000	32	4.82	1084.3	122.4	3,898	440	6,201	700	12,235	1,381		
PH722F0500 KX501VF0020 MF	100.0	2,500	2,500	3,500	32	5.32	1230.0	138.9	3,898	440	6,201	700	12,401	1,400		
PH722F0350 KX501VF0030 MF	105.0	3,000	3,000	4,000	32	4.81	1229.7	138.8	3,898	440	6,201	700	12,401	1,400		
PH722F0400 KX501VF0030 MF	120.0	3,000	3,000	4,000	32	4.80	1084.8	122.5	3,898	440	6,201	700	12,235	1,381		
PH722F0700 KX501VF0020 MF	140.0	2,500	2,500	3,500	32	5.31	1238.6	139.8	3,898	440	5,758	650	11,127	1,256		
PH722F0500 KX501VF0030 MF	150.0	3,000	3,000	4,000	32	4.79	1230.0	138.9	3,898	440	6,201	700	12,401	1,400		
PH722F1000 KX501VF0020 MF	200.0	2,500	2,500	3,500	32	5.31	985.5	111.3	2,657	300	4,429	500	8,858	1,000		
PH722F0700 KX501VF0030 MF	210.0	3,000	3,000	4,000	32	4.79	1238.6	139.8	3,898	440	5,758	650	11,127	1,256		
PH722F1000 KX501VF0030 MF	300.0	3,000	3,000	4,000	32	4.79	985.5	111.3	2,657	300	4,429	500	8,858	1,000		

PHKX

Index of Symbols: MF — Motor adapter with FlexiAdapt® coupling; L — Large Input; C — ServoCool

See Page 104 for Options and Part Number Configuration.



"PHKX" Series – Right Angle ServoFit® Precision Planetary Gearhead Selection Data



PHKX

Part Number (Gearhead + Input)	Exact Ratio i	Max. Input RPM (n ₁)			Max. Motor Shaft øD ⁶ mm	Input Inertia J ₁ kgcm ²	Torsional Stiffness per arcmin C ₂		Output Torque					
		Continuous		Cyclic			in.lbs.	Nm	Nominal ¹⁾		Acceleration		Peak ²⁾	
		Mounting Position							in.lbs.	Nm	M _{2N}		M _{2B}	
		EL 1,2,5,6	EL 3,4	All			in.lbs.	Nm			in.lbs.	Nm	in.lbs.	Nm
PH821_KX8 with Motor Mounting Plate														
PH821F0040 KX801VF0010 MF	4.000	1,000	750	1,750	48	101.43	1518.5	171.4	6,803	768	9,354	1,056	14,286	1,613
PH821F0050 KX801VF0010 MF	5.000	1,000	750	1,750	48	92.44	1975.1	223.0	8,504	960	11,693	1,320	17,858	2,016
PH821F0070 KX801VF0010 MF	7.000	1,000	750	1,750	48	85.00	2506.2	282.9	8,858	1,000	14,173	1,600	24,900	2,811
PH821F0040 KX801VF0020 MF	8.000	1,100	1,100	2,500	48	54.94	1518.5	171.4	6,803	768	9,354	1,056	17,007	1,920
PH821F0050 KX801VF0020 MF	10.000	1,100	1,100	2,500	48	52.69	1975.1	223.0	8,504	960	11,693	1,320	21,259	2,400
PH821F0070 KX801VF0020 MF	14.000	1,100	1,100	2,500	48	50.83	2506.2	282.9	8,858	1,000	14,173	1,600	24,900	2,811
PH821F0050 KX801VF0030 MF	15.000	1,300	1,300	3,000	48	44.92	1975.1	223.0	8,504	960	11,693	1,320	21,259	2,400
PH821F0100 KX801VF0020 MF	20.000	1,100	1,100	2,500	48	49.88	2306.0	260.3	7,086	800	10,630	1,200	21,259	2,400
PH821F0070 KX801VF0030 MF	21.000	1,300	1,300	3,000	48	44.09	2506.2	282.9	8,858	1,000	14,173	1,600	24,900	2,811
PH821F0100 KX801VF0030 MF	30.000	1,300	1,300	3,000	48	43.67	2306.0	260.3	7,086	800	10,630	1,200	21,259	2,400
PH822_KX7 with Motor Mounting Plate														
PH822F0350 KX701VF0010 MF	35.000	1,800	1,600	2,250	38	26.15	3366.3	380.0	11,073	1,250	17,716	2,000	28,346	3,200
PH822F0200 KX701VF0020 MF	40.000	1,800	1,800	3,000	38	15.73	3223.4	363.9	11,073	1,250	17,716	2,000	28,346	3,200
PH822F0160 KX701VF0030 MF	48.000	2,100	2,100	3,500	38	12.93	2839.5	320.6	9,744	1,100	16,476	1,860	28,346	3,200
PH822F0250 KX701VF0020 MF	50.000	1,800	1,800	3,000	38	15.35	3302.4	372.8	11,073	1,250	17,716	2,000	28,346	3,200
PH822F0280 KX701VF0020 MF	56.000	1,800	1,800	3,000	38	15.08	3015.7	340.5	9,744	1,100	17,716	2,000	28,346	3,200
PH822F0200 KX701VF0030 MF	60.000	2,100	2,100	3,500	38	12.87	3223.4	363.9	11,073	1,250	17,716	2,000	28,346	3,200
PH822F0350 KX701VF0020 MF	70.000	1,800	1,800	3,000	38	15.03	3366.3	380.0	11,073	1,250	17,716	2,000	28,346	3,200
PH822F0250 KX701VF0030 MF	75.000	2,100	2,100	3,500	38	12.70	3302.4	372.8	11,073	1,250	17,716	2,000	28,346	3,200
PH822F0400 KX701VF0020 MF	80.000	1,800	1,800	3,000	38	14.90	2957.5	333.9	9,744	1,100	17,007	1,920	28,346	3,200
PH822F0280 KX701VF0030 MF	84.000	2,100	2,100	3,500	38	12.58	3015.7	340.5	9,744	1,100	17,716	2,000	28,346	3,200
PH822F0500 KX701VF0020 MF	100.000	1,800	1,800	3,000	38	14.88	3319.6	374.8	11,073	1,250	17,716	2,000	28,346	3,200
PH822F0350 KX701VF0030 MF	105.000	2,100	2,100	3,500	38	12.56	3366.3	380.0	11,073	1,250	17,716	2,000	28,346	3,200
PH822F0400 KX701VF0030 MF	120.000	2,100	2,100	3,500	38	12.50	2957.5	333.9	9,744	1,100	17,007	1,920	28,346	3,200
PH822F0700 KX701VF0020 MF	140.000	1,800	1,800	3,000	38	14.86	3396.9	383.5	8,858	1,000	14,173	1,600	24,900	2,811
PH822F0500 KX701VF0030 MF	150.000	2,100	2,100	3,500	38	12.49	3319.6	374.8	11,073	1,250	17,716	2,000	28,346	3,200
PH822F1000 KX701VF0020 MF	200.000	1,800	1,800	3,000	38	14.85	2615.2	295.2	7,086	800	10,630	1,200	21,259	2,400
PH822F0700 KX701VF0030 MF	210.000	2,100	2,100	3,500	38	12.49	3396.9	383.5	8,858	1,000	14,173	1,600	24,900	2,811
PH822F1000 KX701VF0030 MF	300.000	2,100	2,100	3,500	38	12.48	2615.2	295.2	7,086	800	10,630	1,200	21,259	2,400

¹⁾ Based on input speed: n₁ = 2000 RPM

For torque at higher input speeds (M_{2NX}) solve the formula, where n₁ = Actual Input Speed. $M_{2NX} = \frac{M_{2N}}{\sqrt[3]{\frac{n_1}{2000}}}$

²⁾ Maximum momentary torque for emergency stops or heavy shock load. Admissible stops per life of gearhead = 1,000 stops maximum.



"PHKX" Series – Right Angle ServoFit® Precision Planetary Gearhead Selection Data



Part Number (Gearhead + Input)	Exact Ratio i	Max. Input RPM (n _i)			Max. Motor Shaft øD ⁶ mm	Input Inertia J ₁ kgcm ²	Torsional Stiffness per arcmin C ₂		Output Torque							
		Continuous		Cyclic			in.lbs.	Nm	Nominal ¹⁾		Acceleration		Peak ²⁾			
		Mounting Position							in.lbs.	Nm	M _{2N}		M _{2B}		M _{2PEAK}	
		EL 1,2,5,6	EL 3,4	All							in.lbs.	Nm	in.lbs.	Nm	in.lbs.	Nm
PH932_KX8 with Motor Mounting Plate																
PH932F0120 KX801VF0010 MF	12.00	1,000	750	2,000	48	127.49	6,976.3	787.6	19,771	2,232	27,185	3,069	48,005	5,419		
PH932F0160 KX801VF0010 MF	16.00	1,000	750	2,000	48	97.42	8,159.5	921.1	26,361	2,976	36,247	4,092	64,006	7,226		
PH932F0180 KX801VF0010 MF	18.00	1,000	750	2,000	48	121.44	8,150.2	920.1	26,574	3,000	39,861	4,500	72,007	8,129		
PH932F0200 KX801VF0010 MF	20.00	1,000	750	2,000	48	89.78	8,781.9	991.4	26,574	3,000	44,290	5,000	80,008	9,032		
PH932F0120 KX801VF0020 MF	24.00	1,100	1,100	2,500	48	61.45	6,976.3	787.6	19,771	2,232	27,185	3,069	57,148	6,452		
PH932F0300 KX801VF0010 MF	30.00	1,000	750	2,000	48	87.60	9,124.2	1,030.1	26,574	3,000	39,861	4,500	79,722	9,000		
PH932F0160 KX801VF0020 MF	32.00	1,100	1,100	2,500	48	53.94	8,159.5	921.1	26,361	2,976	36,247	4,092	76,198	8,602		
PH932F0180 KX801VF0020 MF	36.00	1,100	1,100	2,500	48	59.94	8,150.2	920.1	26,574	3,000	39,861	4,500	79,722	9,000		
PH932F0200 KX801VF0020 MF	40.00	1,100	1,100	2,500	48	52.03	8,781.9	991.4	26,574	3,000	44,290	5,000	88,580	10,000		
PH932F0420 KX801VF0010 MF	42.00	1,000	750	2,000	48	82.59	9,344.6	1,054.9	26,574	3,000	39,861	4,500	79,722	9,000		
PH932F0240 KX801VF0020 MF	48.00	1,100	1,100	2,500	48	53.09	8,813.8	995.0	26,574	3,000	39,861	4,500	79,722	9,000		
PH932F0180 KX801VF0030 MF	54.00	1,300	1,300	3,000	48	48.14	8,150.2	920.1	26,574	3,000	39,861	4,500	79,722	9,000		
PH932F0300 KX801VF0020 MF	60.00	1,100	1,100	2,500	48	51.48	9,124.2	1,030.1	26,574	3,000	39,861	4,500	79,722	9,000		
PH932F0240 KX801VF0030 MF	72.00	1,300	1,300	3,000	48	45.09	8,813.8	995.0	26,574	3,000	39,861	4,500	79,722	9,000		
PH932F0400 KX801VF0020 MF	80.00	1,100	1,100	2,500	48	49.63	8,967.3	1,012.3	23,810	2,688	40,818	4,608	88,580	10,000		
PH932F0420 KX801VF0020 MF	84.00	1,100	1,100	2,500	48	50.23	9,344.6	1,054.9	26,574	3,000	39,861	4,500	79,722	9,000		
PH932F0300 KX801VF0030 MF	90.00	1,300	1,300	3,000	48	44.38	9,124.2	1,030.1	26,574	3,000	39,861	4,500	79,722	9,000		
PH932F0480 KX801VF0020 MF	96.00	1,100	1,100	2,500	48	49.97	9,311.9	1,051.2	26,574	3,000	39,861	4,500	79,722	9,000		
PH932F0600 KX801VF0020 MF	120.0	1,100	1,100	2,500	48	49.50	9,212.2	1,040.0	26,574	3,000	39,861	4,500	79,722	9,000		
PH932F0420 KX801VF0030 MF	126.0	1,300	1,300	3,000	48	43.82	9,344.6	1,054.9	26,574	3,000	39,861	4,500	79,722	9,000		
PH932F0480 KX801VF0030 MF	144.0	1,300	1,300	3,000	48	43.71	9,311.9	1,051.2	26,574	3,000	39,861	4,500	79,722	9,000		
PH932F0600 KX801VF0030 MF	180.0	1,300	1,300	3,000	48	43.50	9,212.2	1,040.0	26,574	3,000	39,861	4,500	79,722	9,000		

PH1032_KX8 with Motor Mounting Plate														
PH1032F0180 KX801VF0010 MF	18.00	1,000	750	2,000	48	124.59	11,532.4	1,301.9	29,657	3,348	40,778	4,604	72,007	8,129
PH1032F0240 KX801VF0010 MF	24.00	1,000	750	2,000	48	95.79	12,907.5	1,457.2	39,542	4,464	54,370	6,138	96,009	10,839
PH1032F0300 KX801VF0010 MF	30.00	1,000	750	2,000	48	88.74	13,584.4	1,533.6	44,290	5,000	66,435	7,500	120,012	13,548
PH1032F0180 KX801VF0020 MF	36.00	1,100	1,100	2,500	48	60.73	11,532.4	1,301.9	29,657	3,348	40,778	4,604	85,723	9,677
PH1032F0420 KX801VF0010 MF	42.00	1,000	750	2,000	48	83.16	14,078.7	1,589.4	44,290	5,000	66,435	7,500	132,870	15,000
PH1032F0240 KX801VF0020 MF	48.00	1,100	1,100	2,500	48	53.53	12,907.5	1,457.2	39,542	4,464	54,370	6,138	114,297	12,903
PH1032F0180 KX801VF0030 MF	54.00	1,300	1,300	3,000	48	48.49	11,532.4	1,301.9	29,657	3,348	40,778	4,604	85,723	9,677
PH1032F0300 KX801VF0020 MF	60.00	1,100	1,100	2,500	48	51.77	13,584.4	1,533.6	44,290	5,000	66,435	7,500	132,870	15,000
PH1032F0240 KX801VF0030 MF	72.00	1,300	1,300	3,000	48	45.29	12,907.5	1,457.2	39,542	4,464	54,370	6,138	114,297	12,903
PH1032F0420 KX801VF0020 MF	84.00	1,100	1,100	2,500	48	50.37	14,078.7	1,589.4	44,290	5,000	66,435	7,500	132,870	15,000
PH1032F0300 KX801VF0030 MF	90.00	1,300	1,300	3,000	48	44.51	13,584.4	1,533.6	44,290	5,000	66,435	7,500	132,870	15,000
PH1032F0480 KX801VF0020 MF	96.00	1,100	1,100	2,500	48	50.08	14,004.5	1,581.0	40,818	4,608	61,226	6,912	132,870	15,000
PH1032F0600 KX801VF0020 MF	120.0	1,100	1,100	2,500	48	49.57	13,780.3	1,555.7	35,715	4,032	61,226	6,912	132,870	15,000
PH1032F0420 KX801VF0030 MF	126.0	1,300	1,300	3,000	48	43.89	14,078.7	1,589.4	44,290	5,000	66,435	7,500	132,870	15,000
PH1032F0480 KX801VF0030 MF	144.0	1,300	1,300	3,000	48	43.76	14,004.5	1,581.0	40,818	4,608	61,226	6,912	132,870	15,000
PH1032F0600 KX801VF0030 MF	180.0	1,300	1,300	3,000	48	43.53	13,780.3	1,555.7	35,715	4,032	61,226	6,912	132,870	15,000

Index of Symbols: MF — Motor adapter with FlexiAdapt® coupling; L — Large Input; C — ServoCool

See Page 104 for Options and Part Number Configuration.

PHKX



"PHKX" Series – Right Angle ServoFit® Precision Planetary Gearhead Dimensional Data



P
H
K
X

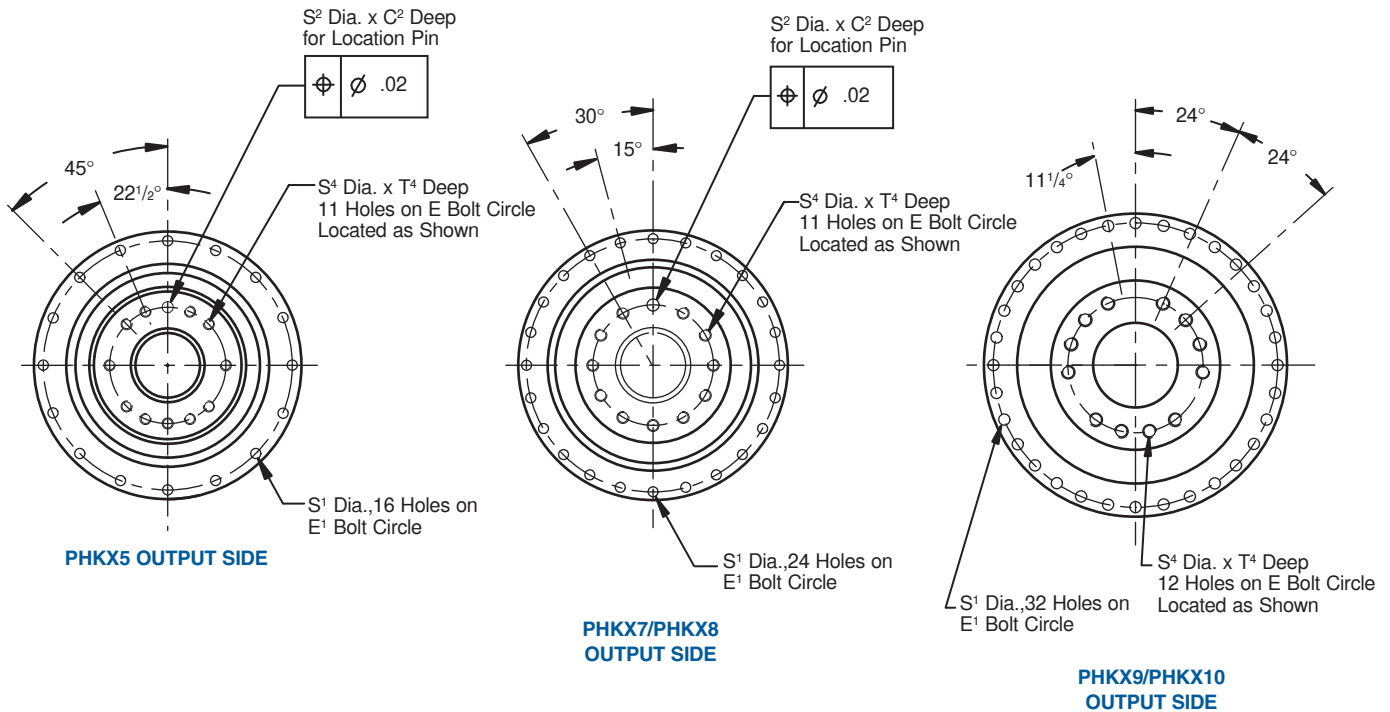
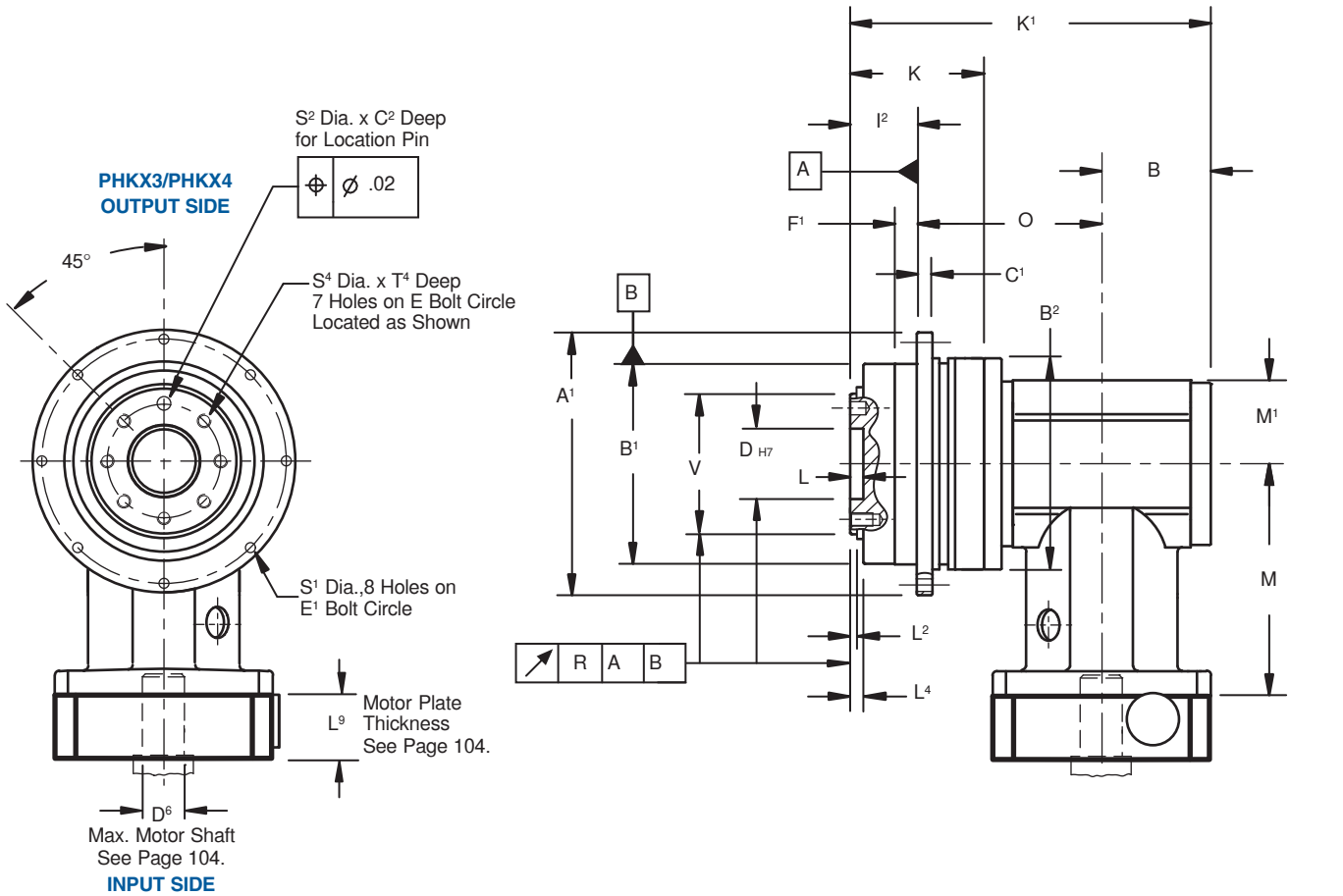



"PHKX" Series – Right Angle ServoFit® Precision Planetary Gearhead Dimensional Data



PHKX

Table No. 1 "PHKX" Series – Gearhead with Motor Plate – Dimensions (mm)

Unit	A ¹ h7	B ¹ h7	B ²	C ¹	C ²	D h7	E	E ¹	F ¹	I ²	L	L ²	L ⁴	R	S ¹	S ² H7
PH3_KX	86 +.000/-0.035	64 +.000/-0.030	70	4	3	20 +.021/-0.0	31.5	79	7	19.5	4	3	3.5	.020	4.5	5 +.012/-0.000
PH4_KX	118 +.000/-0.035	90 +.000/-0.035	95	7	7	31.5 +.025/-0.0	50	109	10	30	6	6	6	.020	5.5	6 +.012/-0.000
PH5_KX	145 +.000/-0.040	110 +.000/-0.035	120	8	7	40 +.025/-0.0	63	135	10	29	6	6	6	.020	5.5	6 +.012/-0.000
PH7_KX	179 +.000/-0.040	140 +.000/-0.040	152	10	7	50 +.025/-0.0	80	168	12	38	6	6	6	.025	6.6	8 +.015/-0.000
PH8_KX	247 +.000/-0.046	200 +.000/-0.046	212	12	10	80 +.030/-0.0	125	233	15	50	8	8	8	.030	9	10 +.015/-0.000
PH9_KX	300 —	255 +.000/-0.052	255	18	—	90 +.035/-0.0	140	280	20	66	12	11	12	.030	13.5	—
PH10_KX	330 —	285 +.000/-0.052	285	20	—	95 +.035/-0.0	160	310	20	75	10	15	15	.040	13.5	—

Table No. 2 "PHKX" Series

Unit	S ⁴	T ⁴	V h7
PH3_KX	M5	7	40 +.000/-0.025
PH4_KX	M6	11	63 +.000/-0.030
PH5_KX	M6	11	80 +.000/-0.030
PH7_KX	M8	14	100 +.000/-0.035
PH8_KX	M10	18	160 +.000/-0.040
PH9_KX	M16	24	180 +.000/-0.046
PH10_KX	M20	30	200 +.000/-0.046

Table No. 3 "PHKX" Series Dimensions (mm)

Unit	B	K	K ¹	M	M ¹	O
PH321_KX3	40	50	133.5	95.5	31	74
PH322_KX3	40	87	169.5	95.5	31	110
PH421_KX4	50	66	167	104	37.5	87
PH422_KX3	40	113	195.5	95.5	31	125.5
PH521_KX5	59	70	193	132	45	105
PH522_KX4	50	124.5	227.5	104	37.5	148.5
PH721_KX7	74	88	239	172.5	60	127
PH722_KX5	59	150	273	132	45	176
PH821_KX8	92	126	317.5	210	75	175.5
PH822_KX7	74	201	352	172.5	60	228
PH932_KX8	92	277.5	470.5	210	75	312.5
PH1032_KX8	92	307	500	210	75	333

Part No. Example
PH421F0050KX401VF0020MF
Specify: Mounting Position
 Paint, if not *Black*
 Motor Information

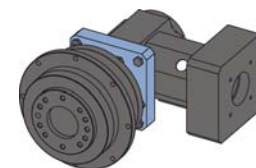

Typical 2 Stage Configuration

See Page 104 for Options and Part Number Configuration.

"PHK" Series – Right Angle ServoFit® Precision Planetary Gearhead Performance Specifications



P
H
K

Size			PH5_K1	PH7_K1	PH7_K2	PH8_K2	PH8_K3	PH9_K5	PH10_K6
Acceleration Torque Maximum	M _{2B}	in.lbs. Nm	2,832 320	5,753 650	6,195 700	13,098 1,480	16,373 1,850	39,861 4,500	66,435 7,500
Output Torque Nominal	M _{2N}	in.lbs. Nm	1,947 220	3,894 440	3,894 440	8,762 990	11,063 1,250	26,574 3,000	44,290 5,000
Input Speed Maximum	n _{1MAX}	Continuous Cyclic	4,000 6,000	4,000 6,000	4,000 5,500	4,000 5,500	3,800 5,000	3,400 4,500	3,100 4,000
Torsional Backlash ¹⁾	Δφ	arcmin	≤4	≤4	≤4.5	≤3.5	≤4	≤4	≤4
Torsional Stiffness Maximum	C ₂	in.lbs./arcmin Nm/arcmin	504 57	903 102	858 97	2,009 227	1,487 168	6,451 728	10,687 1,206
Axial Load Maximum	F _{2AMAX}	lbs. N	934 4,150	1,384 6,150	1,384 6,150	2,261 10,050	2,261 10,050	7,425 33,000	11,250 50,000
Tilting Moment ²⁾ Maximum	M _{2K}	in.lbs. Nm	3,894 440	2,593 1,500	2,593 1,500	30,975 3,500	30,975 3,500	66,375 7,500	77,880 8,800
Weight	m	pounds kg	50 22.5	59 26.8	82 37.3	129 58.6	140 63.6	226 102.4	363 164.8
Noise Level ³⁾	L _{PA}	dB(A)	≤63	≤63	≤64	≤64	≤65	≤65	≤65
Efficiency at Nominal Torque	η	%	≥93 - 96						
Lubrication	Synthetic Oil (ISO VG 150)								
Mounting	Mounting Position must be specified. See Page 116.								
Ambient Temperature	0° C to +40°C (104° F) [Unit temperature ≤ 90° C Max.]								
Finish	Black (RAL 9005)								
Bearing Lifetime ⁴⁾ L _h	hours	L _h > 10,000 hours if M _{2K} /M _{2A} < 1.25 and > 1.00 L _h > 20,000 hours if M _{2K} /M _{2A} > 1.25 and < 1.50 L _h > 30,000 hours if M _{2K} /M _{2A} > 1.5							
Warranty	5 Year Limited (2 Years on normal wear items: bearings, seals, etc.)								

- ¹⁾ Tested at 1.5% of nominal torque and recorded on the output side of the gearhead.
- ²⁾ Rating based on output speed (n₂) of 100 RPM. For values at other speeds see Page 117.
- ³⁾ Measurement at one (1) meter distance with input speed (n₁) of 2000 RPM.
- ⁴⁾ M_{2A} equals actual tilting moment of the application. See Page 117 for calculation details.

WARNING: In order to insure that the specified torque ratings are attained, it is essential to attach the gear units to the machine with a grade 12.9 fastener.

Refer to Page 302 for ServoFit Precision Planetary Gearhead Selection Procedure.



"PHK" Series – Right Angle ServoFit® Precision Planetary Gearhead Features

The "PHK" Series combines the "PH" Series ServoFit Precision Planetary Gearheads with a reduced backlash SMS right angle Series "K" to provide a configuration that is a smooth, precise, and reliable drive with the benefit of direct mounting to many types of equipment without a coupling. All units are lubricated for life with synthetic oil and sealed to IP65 standards to prevent lubricant contamination for long life.

Some features are:

- High Axial Load Capacity
- Superior Torsional Stiffness
- Low Backlash
- Low Noise
- High Input Speed
- Advanced Helical Gear Technology
- Ratios up to 561:1
- Compact
- Wide Selection of IEC, NEMA, or Customized Motor Wide Plates
- 5 Year Limited Warranty (2 Year on bearings, seals, etc.)

PHK

The patented motor coupling is designed to allow thermal expansion of the motor shaft — ensuring long motor life by preventing thrust load on the motor bearings.

The motor shaft adapter system allows installation of motor in minutes — no special tools required

Motor plate can easily be changed to fit your choice of motors

Adapter bushings to fit all motor shafts — no key required

Motor plate pilot toleranced to fit your motor for precise concentricity

Ring gear machined integral to the housing — not welded or pressed in — provides greater concentricity and more precise alignment

Blind pilot hole

The output flange dimensions are ISO 9409 and allow easy mounting to rotary or indexing tables, pinions, timing belt pulleys, transmission shafting, etc., without using a coupling.

FKM double-lip radial oil seals for continuous duty applications and very good chemical resistance.

HeliCamber® gear technology provides minimum wear, low backlash, and low noise

Highly efficient spiral bevel gearsets provide quiet operation and excellent torque carrying capacity.

Oversized tapered roller bearings and shafts for high radial load capacity and superior torsional stiffness

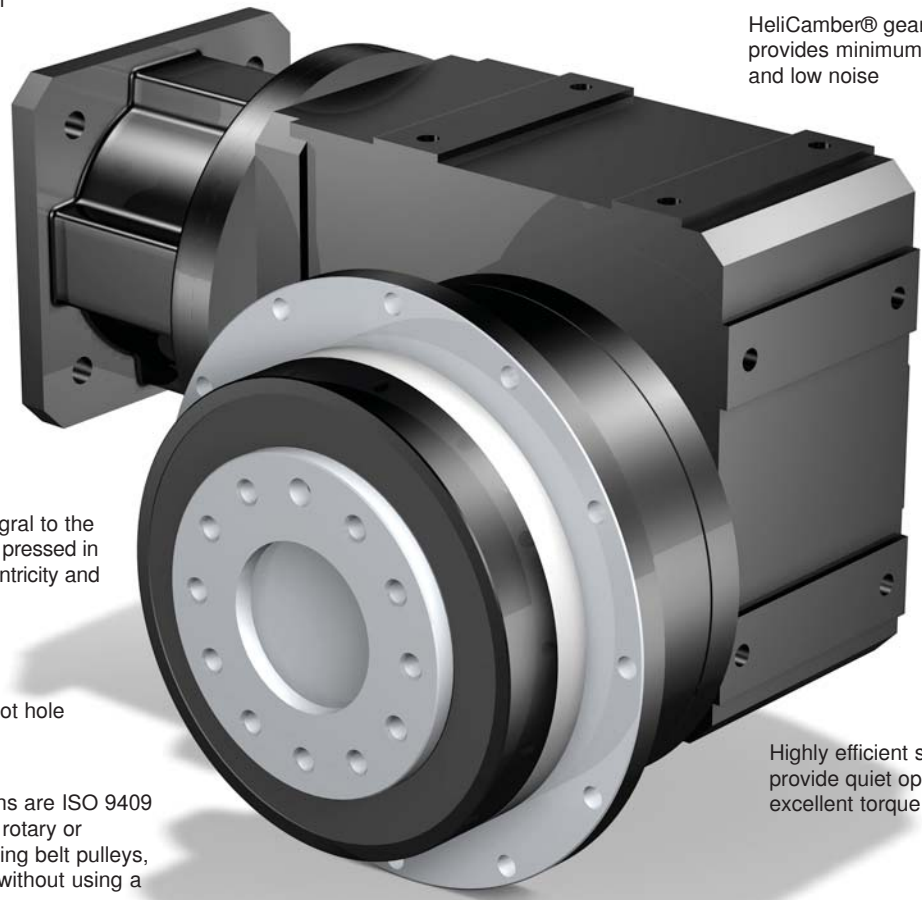

"PHK" Series – Right Angle ServoFit® Precision Planetary Gearhead



Part No. Explanation

PH 5 2 1 F 0050 K102VF 0060 MT10

Series	Unit No.	Generation	No. of Stages	Output Flange	Ratio of PH	Right Angle	Ratio of Right Angle	Input
Planetary Unit			PH		ServoFit Precision Planetary Gearhead			
Size	5				5, 7, 8, 9, 10			
Generation		2			Generation No.			
No. of Stages			1		1 = 1 Stage, 2 = 2 Stage)			
Housing Style				F	Standard Output Flange Mounting			
Ratio				0050	Approximate: 0050 = 5.00:1 (range of 3:1 up to 100:1)			
Right Angle Unit					K102VF	Series K102 Helical Bevel with Shaft (V) and Flange (F)		
Ratio					0060	Approximate: 0060 = 6.00:1 (range of 4:1 up to 78:1)		
Motor Adapter					MT10	TriAdapt Motor Adapter MT10 , MT20, MT30, MT40, MT50		

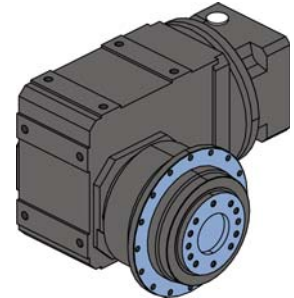

Motor information must be specified.

Motor Mounting Specifications

STOBER ServoFit Gearheads will fit the motor of your choice by assembling the correct motor mounting plate between the motor and the gearhead. **When ordering a gearhead, specify the motor manufacturer and part number, provide the motor drawing with dimensions, or specify the motor mounting dimensions.** The motor plate thickness (L^9) dimension will be determined by the motor shaft length. The minimum motor plate thickness is shown below. For a precise dimension on a specific motor, contact STOBER Technical Support.

The following dimensions are required to provide the correct motor mounting plate:

1. D^6 Motor Shaft Diameter (If an adapter bushing is required it will be supplied with the motor plate.)
2. D^7 Pilot Diameter
3. D^8 Bolt Circle Diameter
4. D^9 Bolt Diameter
5. L^{11} Motor Shaft Length
6. L^{12} Pilot Length
7. L^{14} Square Flange (Optional — Motor plate will typically be made to match.)

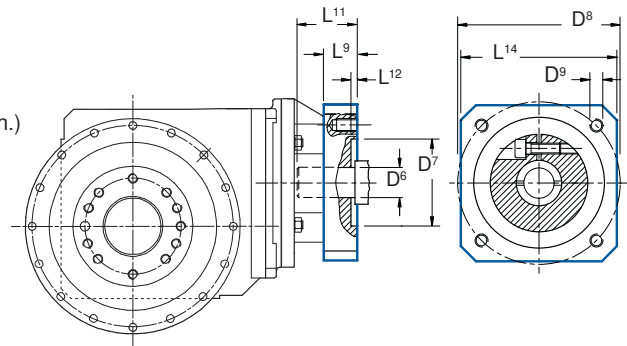

Table No.1

Input Option	Shaft D^6 Max.	Motor Plate Thickness L^9 Min.
MT10	19	21
MT20	24	24
MT30	38	25
MT40	48	33
MT50	60	43

Mounting Position

All ServoFit Precision Planetary units are filled with synthetic oil and lubricated for life. The units should never be opened or the oil changed. All ServoFit Modular System units are shipped filled with the required amount of Mobilgear XP600 lubrication. In order to provide the proper lubrication quantity **the mounting position must be specified at the time the unit is ordered.**

PH5K1 – PH8K3

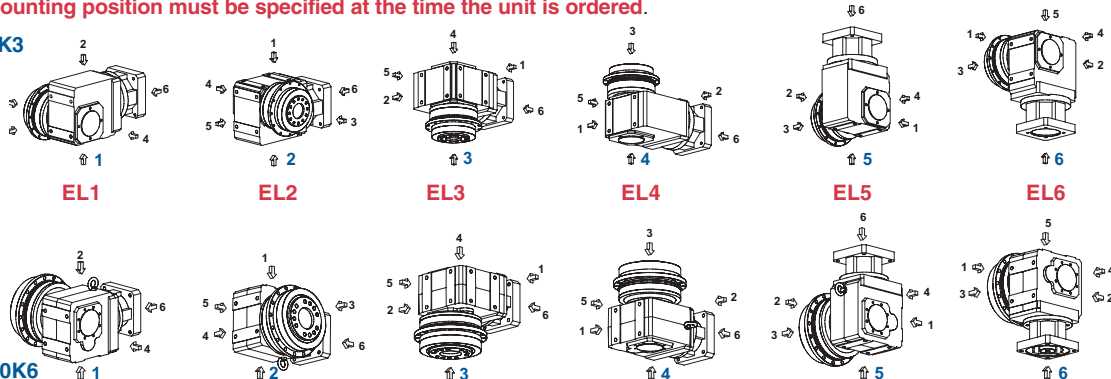

PH9K5 – PH10K6



"PHK" Series – Right Angle ServoFit® Precision Planetary Gearhead

The "PH" Series planetary unit can be mounted on the left or right side of the K Series unit. **Side 3 or Side 4 must be specified on the order.**

PH5K1 – PH8K3

PH9K5 – PH10K6

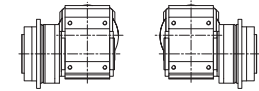

Side 3

Side 4

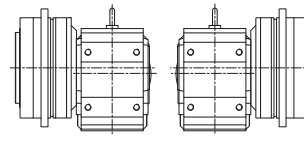

Side 3

Side 4

Viewed from Side 5, EL1 Mounting Position

Maintenance

With STOBER reducers very little maintenance is required under normal operating conditions. Units supplied without breathers are lubricated for life. Units K1 through K3 in the PHK Series do not have breathers.

Direction of Rotation

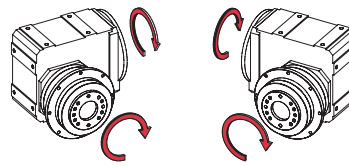

Side 3

Side 4

EL1 Mounting Position, Input CCW

Permissible Output Load and Tilting Moments

The permissible load and tilting moment values are based on an output speed of 100 RPM. For higher speeds the following applies, where n_2 is the desired speed:

$$F_{2AX} = \frac{F_{2A}}{\sqrt[3]{\frac{n_2}{100}}} \quad M_{2KX} = \frac{M_{2K}}{\sqrt[3]{\frac{n_2}{100}}}$$

The application input tilting moment should be determined by the following formula:

$$M_{2A} = \frac{F_{2a} \cdot y_2 + F_{2rb} \cdot (X_2 + Z_2)}{1000} \leq M_{2KB}$$

$$M_{2ka} = \sqrt[3]{\frac{n_{2b1} \cdot t_{b1} \cdot M_{2kb1}^3 + \dots + n_{2bn} \cdot t_{bn} \cdot M_{2kbn}^3}{n_{2b1} \cdot t_{b1} + \dots + n_{2bn} \cdot t_{bn}}} \leq M_{2K}$$

$$F_{2r} = \sqrt[3]{\frac{n_{2b1} \cdot t_{b1} \cdot F_{2rb1}^3 + \dots + n_{2bn} \cdot t_{bn} \cdot F_{2rbn}^3}{n_{2b1} \cdot t_{b1} + \dots + n_{2bn} \cdot t_{bn}}} \leq F_{2R}$$

where:

- F_{2a} Axial Load at Output Shaft
- F_{2A} Permissible Axial Load
- F_{2r} Radial Load at Output Shaft
- F_{2R} Permissible Radial Load
- F_{2RB} Acceleration Permissible Radial Load
- M_{2K} Rated Tilting Torque
- M_{2k} Equivalent Tilting Load
- M_{2KB} Acceleration Tilting Torque
- Z_2 Distance Factor

The hours of life (L_h) of the unit can be determined by the following formula:

bearing life for duty cycle $\leq 40\%$

$L_h > 10,000$ hours if $M_{2K}/M_{2A} < 1.25$ and > 1
 $L_h > 20,000$ hours if $M_{2K}/M_{2A} > 1.25$ and > 1.5
 $L_h > 30,000$ hours if $M_{2K}/M_{2A} < 1.5$

bearing life for duty cycle $\geq 40\%$

$$L_{hA} = L_h \left(\frac{40\%}{\text{Duty Cycle}} \right)$$

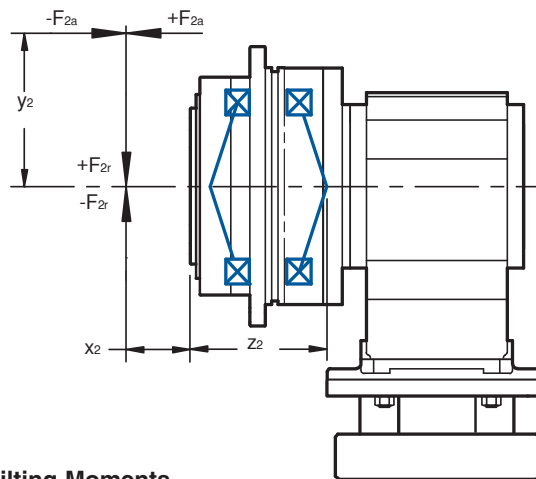

Table No. 2 Permissible Output Load and Tilting Moments

Unit No.	Z_2		F_{2AMAX}		F_{2R}		F_{2RB}		M_{2K}		M_{2KB}		C_{2K}	
	mm	inches	N	lbs.	N	lbs.	N	lbs.	Nm	in.lbs.	Nm	in.lbs.	Nm/arcmin	In.lbs/arcmin
PH5K	97	3.82	4,150	934	4,536	1,021	4,897	1,102	440	3,717	475	4,204	380	3,363
PH7K	88	3.46	6,150	1,384	17,045	3,835	17,045	3,835	1,500	13,275	1,500	13,275	500	4,425
PH8K	126	4.96	10,050	2,261	27,778	6,250	27,778	6,250	3,500	30,975	3,500	30,975	1,550	13,718
PH9K	155	6.10	33,000	7,425	48,387	10,887	70,968	15,938	7,500	66,375	11,000	97,350	7,500	66,375
PH10K	171	6.73	50,000	11,250	51,462	11,579	73,099	16,447	8,800	77,880	12,500	110,625	9,500	84,075

During EMERGENCY OFF operation (maximum stops per gearhead = 1000) the permissible values in the table for F_{2A} , F_{2R} , and M_{2K} can be multiplied by a factor of 2.



"PHK" Series – Right Angle ServoFit® Precision Planetary Gearhead Selection Data



PHK

Part Number	Reducer Ratio i		Input RPM			Backlash arcmins $\Delta\phi$	Input Inertia J ₁ kgcm ²	Torsional Stiffness per arcmin C ₂		Output Torque					
			Maximum		Nominal ¹⁾ M _{2N} ≤ 2000 RPM					Acceleration		Peak ²⁾			
	Continuous	Cyclic						M _{2B}		M _{2PEAK}					
	Nom.	Exact	n _{1DBH}	n _{1DBV}	n _{1ZB}			in.lbs.	Nm	in.lbs.	Nm	in.lbs.	Nm	in.lbs.	Nm
PH521_K102 with Motor Mounting Plate															
PH521F0040K102VF0040MT10	16.00	16/1	3,300	2,800	4,500	4,5	1.56	334	38	1,584	179	1,584	179	2,148	243
PH521F0040K102VF0040MT20	16.00	16/1	3,300	2,800	4,500	4,5	2.16	343	39	1,860	210	2,835	320	4,296	485
PH521F0050K102VF0040MT10	20.00	20/1	3,300	2,800	4,500	4	1.53	418	47	1,860	210	1,980	223	2,685	303
PH521F0050K102VF0040MT20	20.00	20/1	3,300	2,800	4,500	4	2.13	427	48	1,860	210	2,835	320	5,315	600
PH521F0050K102VF0056MT10	27.84	7600/273	3,300	2,800	4,500	4	1.29	466	53	1,860	210	2,756	311	3,738	422
PH521F0050K102VF0056MT20	27.84	7600/273	3,300	2,800	4,500	4	1.89	472	53	1,860	210	2,835	320	5,315	600
PH521F0050K102VF0060MT10	30.00	30/1	3,300	2,800	4,500	4	1.10	475	54	1,860	210	2,835	320	4,028	455
PH521F0050K102VF0060MT20	30.00	30/1	3,300	2,800	4,500	4	1.70	480	54	1,860	210	2,835	320	5,315	600
PH521F0050K102VF0066MT10	33.22	299/9	3,600	3,300	5,000	4	1.02	484	55	1,860	210	2,835	320	4,460	503
PH521F0050K102VF0066MT20	33.22	299/9	3,500	3,300	5,000	4	1.62	489	55	1,860	210	2,835	320	5,315	600
PH521F0050K102VF0083MT10	41.55	1911/46	3,600	3,300	5,000	4	0.90	501	57	1,860	210	2,835	320	5,315	600
PH521F0050K102VF0083MT20	41.55	1911/46	3,500	3,300	5,000	4	1.50	503	57	1,860	210	2,835	320	5,315	600
PH521F0050K102VF0092MT10	46.25	8740/189	3,600	3,300	5,000	4	0.94	506	57	1,860	210	2,835	320	5,315	600
PH521F0050K102VF0092MT20	46.25	8740/189	3,500	3,300	5,000	4	1.54	509	57	1,860	210	2,835	320	5,315	600
PH521F0050K102VF0115MT10	57.83	1330/23	3,600	3,300	5,000	4	0.84	515	58	1,860	210	2,835	320	5,315	600
PH521F0050K102VF0115MT20	57.83	1330/23	3,500	3,300	5,000	4	1.44	517	58	1,860	210	2,835	320	5,315	600
PH521F0050K102VF0140MT10	70.57	494/7	4,000	3,800	5,500	4	0.78	521	59	1,860	210	2,835	320	5,315	600
PH521F0050K102VF0140MT20	70.57	494/7	3,500	3,500	5,000	4	1.38	522	59	1,860	210	2,835	320	5,315	600
PH521F0050K102VF0175MT10	87.82	10450/119	4,000	3,800	5,500	4	0.73	525	59	1,860	210	2,835	320	5,315	600
PH521F0050K102VF0175MT20	87.82	10450/119	3,500	3,500	5,000	4	1.33	526	59	1,860	210	2,835	320	5,315	600
PH521F0050K102VF0230MT10	116.3	5700/49	4,000	4,000	6,000	4	0.69	528	60	1,860	210	2,835	320	5,315	600
PH521F0050K102VF0230MT20	116.3	5700/49	3,500	3,500	5,000	4	1.29	528	60	1,860	210	2,835	320	5,315	600
PH521F0050K102VF0280MT10	140.2	2945/21	4,000	4,000	6,000	4	0.67	529	60	1,860	210	2,835	320	5,315	600
PH521F0050K102VF0280MT20	140.2	2945/21	3,500	3,500	5,000	4	1.27	530	60	1,860	210	2,835	320	5,315	600
PH521F0050K102VF0350MT10	175.5	3686/21	4,000	4,000	6,000	4	0.64	530	60	1,860	210	2,835	320	5,315	600
PH521F0050K102VF0350MT20	175.5	3686/21	3,500	3,500	5,000	4	1.24	531	60	1,860	210	2,835	320	5,315	600
PH521F0050K102VF0470MT10	234.6	11495/49	4,000	4,000	6,000	4	0.63	531	60	1,860	210	2,835	320	5,315	600
PH521F0050K102VF0560MT10	280.5	5890/21	4,000	4,000	6,000	4	0.62	531	60	1,860	210	2,835	320	4,903	553

¹⁾ Maximum torque for continuous input RPM - horizontal output position.
²⁾ Maximum momentary torque for emergency stops or heavy shock load.
 Admissible stops per life of reducer = 1,000 stops maximum.

Index of Symbols

i	... Exact Ratio = Exact Tooth Count
J ₁	... Reducer Inertia
C ₂	... Torsional Stiffness
n _{1DBH}	... Maximum Continuous Input RPM Horizontal Mounting - EL1, 2, 5, 6
n _{1DBV}	... Maximum Continuous Input RPM Vertical Position - EL3 and EL4
n _{1ZB}	... Maximum Cyclic Input RPM
M _{2N}	... Nominal Torque @ 2000 RPM Input
M _{2B}	... Acceleration Torque Maximum
M _{2PEAK}	... Peak Torque



"PHK" Series – Right Angle ServoFit® Precision Planetary Gearhead Selection Data



Part Number	Reducer Ratio i		Input RPM				Backlash arcmins $\Delta\phi$	Input Inertia J ₁ kgcm ²	Torsional Stiffness per arcmin C ₂ in.lbs. Nm		Output Torque					
			Maximum			Nominal ¹⁾ M _{2N ≤ 2000 RPM} in.lbs. Nm					Acceleration		Peak ²⁾ M _{2PEAK} in.lbs. Nm			
	Nom.	Exact	n _{1DBH}	n _{1DBV}	n _{1ZB}		in.lbs.	Nm	in.lbs.	Nm	in.lbs.	Nm				
			Continuous	Cyclic												
PH721_K102 with Motor Mounting Plate Continued Next Page																
PH721F0070K102VF0040MT10	28.00	28/1	3,300	2,800	4,500	4	1.55	765	86	2,772	313	2,772	313	3,759	424	
PH721F0070K102VF0040MT20	28.00	28/1	3,300	2,800	4,500	4	2.15	781	88	3,443	389	5,543	626	7,518	849	
PH721F0070K102VF0056MT10	38.98	1520/39	3,300	2,800	4,500	4	1.30	847	96	3,844	434	3,858	436	5,233	591	
PH721F0070K102VF0056MT20	38.98	1520/39	3,300	2,800	4,500	4	1.90	857	97	3,844	434	5,758	650	10,465	1,181	
PH721F0100K102VF0040MT10	40.00	40/1	3,300	2,800	4,500	3.5	1.51	794	90	2,657	300	3,959	447	5,370	606	
PH721F0100K102VF0040MT20	40.00	40/1	3,300	2,800	4,500	3.5	2.11	802	91	2,657	300	4,429	500	8,858	1,000	
PH721F0070K102VF0060MT10	42.00	42/1	3,300	2,800	4,500	4	1.11	861	97	3,898	440	4,157	469	5,639	637	
PH721F0070K102VF0060MT20	42.00	42/1	3,300	2,800	4,500	4	1.71	870	98	3,898	440	5,758	650	10,972	1,239	
PH721F0070K102VF0066MT10	46.51	2093/45	3,600	3,300	5,000	4	1.03	877	99	3,898	440	4,603	520	6,244	705	
PH721F0070K102VF0066MT20	46.51	2093/45	3,500	3,300	5,000	4	1.63	885	100	3,898	440	5,758	650	10,972	1,239	
PH721F0100K102VF0056MT10	55.68	15200/273	3,300	2,800	4,500	3.5	1.28	835	94	2,657	300	4,429	500	7,475	844	
PH721F0100K102VF0056MT20	55.68	15200/273	3,300	2,800	4,500	3.5	1.88	840	95	2,657	300	4,429	500	8,858	1,000	
PH721F0070K102VF0083MT10	58.16	13377/230	3,600	3,300	5,000	4	0.91	905	102	3,898	440	5,757	650	7,809	882	
PH721F0070K102VF0083MT20	58.16	13377/230	3,500	3,300	5,000	4	1.51	909	103	3,898	440	5,758	650	10,972	1,239	
PH721F0100K102VF0060MT10	60.00	60/1	3,300	2,800	4,500	3.5	1.09	842	95	2,657	300	4,429	500	8,055	909	
PH721F0100K102VF0060MT20	60.00	60/1	3,300	2,800	4,500	3.5	1.69	846	95	2,657	300	4,429	500	8,858	1,000	
PH721F0070K102VF0092MT10	64.74	1748/27	3,600	3,300	5,000	4	0.94	914	103	3,898	440	5,758	650	8,692	981	
PH721F0070K102VF0092MT20	64.74	1748/27	3,500	3,300	5,000	4	1.54	918	104	3,898	440	5,758	650	10,972	1,239	
PH721F0100K102VF0066MT10	66.44	598/9	3,600	3,300	5,000	3.5	1.02	849	96	2,657	300	4,429	500	8,858	1,000	
PH721F0100K102VF0066MT20	66.44	598/9	3,500	3,300	5,000	3.5	1.62	852	96	2,657	300	4,429	500	8,858	1,000	
PH721F0070K102VF0100MT10	70.98	3549/50	4,000	3,800	5,500	4	0.83	921	104	3,898	440	5,758	650	9,529	1,076	
PH721F0070K102VF0100MT20	70.98	3549/50	3,500	3,500	5,000	4	1.43	925	104	3,898	440	5,758	650	10,972	1,239	
PH721F0070K102VF0115MT10	80.96	1862/23	3,600	3,300	5,000	4	0.85	929	105	3,898	440	5,758	650	10,869	1,227	
PH721F0070K102VF0115MT20	80.96	1862/23	3,500	3,300	5,000	4	1.45	932	105	3,898	440	5,758	650	10,972	1,239	
PH721F0100K102VF0083MT10	83.09	1911/23	3,600	3,300	5,000	3.5	0.90	861	97	2,657	300	4,429	500	8,858	1,000	
PH721F0100K102VF0083MT20	83.09	1911/23	3,500	3,300	5,000	3.5	1.50	864	97	2,657	300	4,429	500	8,858	1,000	
PH721F0070K102VF0125MT10	88.33	3003/34	4,000	3,800	5,500	4	0.76	934	105	3,898	440	5,758	650	10,972	1,239	
PH721F0070K102VF0125MT20	88.33	3003/34	3,500	3,500	5,000	4	1.36	936	106	3,898	440	5,758	650	10,972	1,239	
PH721F0100K102VF0092MT10	92.49	17480/189	3,600	3,300	5,000	3.5	0.93	866	98	2,657	300	4,429	500	8,858	1,000	
PH721F0100K102VF0092MT20	92.49	17480/189	3,500	3,300	5,000	3.5	1.53	867	98	2,657	300	4,429	500	8,858	1,000	
PH721F0070K102VF0140MT10	98.80	494/5	4,000	3,800	5,500	4	0.79	938	106	3,898	440	5,758	650	10,972	1,239	
PH721F0070K102VF0140MT20	98.80	494/5	3,500	3,500	5,000	4	1.39	940	106	3,898	440	5,758	650	10,972	1,239	
PH721F0100K102VF0115MT10	115.7	2660/23	3,600	3,300	5,000	3.5	0.84	872	98	2,657	300	4,429	500	8,858	1,000	
PH721F0100K102VF0115MT20	115.7	2660/23	3,500	3,300	5,000	3.5	1.44	873	99	2,657	300	4,429	500	8,858	1,000	
PH721F0070K102VF0165MT10	117.0	117/1	4,000	4,000	6,000	4	0.70	943	107	3,898	440	5,758	650	10,972	1,239	
PH721F0070K102VF0165MT20	117.0	117/1	3,500	3,500	5,000	4	1.30	945	107	3,898	440	5,758	650	10,972	1,239	

PHK

Max. Motor Shaft Diameter

Adapter	Shaft	Adapter	Shaft	Adapter	Shaft
MT10	19	MT30	38	MT50	60
MT20	24	MT40	48		

See Page 116 for Options and Part Number Configuration.



"PHK" Series – Right Angle ServoFit® Precision Planetary Gearhead Selection Data



PHK

Part Number	Reducer Ratio i		Input RPM			Backlash arcmins $\Delta\phi$	Input Inertia J ₁ kgcm ²	Torsional Stiffness per arcmin C ₂		Output Torque					
			Maximum							Nominal ¹⁾		Acceleration		Peak ²⁾	
	Nom.	Exact	n _{1DBH}	n _{1DBV}	n _{1ZB}			M _{2N} ≤ 2000 RPM	M _{2B}	M _{2PEAK}					
										Continuous	Cyclic	in.lbs.	Nm	in.lbs.	Nm
PH721_K102 with Motor Mounting Plate <i>Continued</i>															
PH721F0070K102VF0175MT10	122.9	2090/17	4,000	3,800	5,500	4	0.74	945	107	3,898	440	5,758	650	10,972	1,239
PH721F0070K102VF0175MT20	122.9	2090/17	3,500	3,500	5,000	4	1.34	946	107	3,898	440	5,758	650	10,972	1,239
PH721F0070K102VF0200MT10	141.1	2821/20	4,000	4,000	6,000	4	0.68	948	107	3,898	440	5,758	650	10,972	1,239
PH721F0070K102VF0200MT20	141.1	2821/20	3,500	3,500	5,000	4	1.28	949	107	3,898	440	5,758	650	10,972	1,239
PH721F0070K102VF0230MT10	162.9	1140/7	4,000	4,000	6,000	4	0.69	950	107	3,898	440	5,758	650	10,972	1,239
PH721F0070K102VF0230MT20	162.9	1140/7	3,500	3,500	5,000	4	1.29	951	107	3,898	440	5,758	650	10,972	1,239
PH721F0070K102VF0250MT10	176.5	8827/50	4,000	4,000	6,000	4	0.65	951	107	3,898	440	5,758	650	10,972	1,239
PH721F0070K102VF0250MT20	176.5	8827/50	3,500	3,500	5,000	4	1.25	952	107	3,898	440	5,758	650	10,972	1,239
PH721F0070K102VF0280MT10	196.3	589/3	4,000	4,000	6,000	4	0.67	952	107	3,898	440	5,758	650	10,972	1,239
PH721F0070K102VF0280MT20	196.3	589/3	3,500	3,500	5,000	4	1.27	953	108	3,898	440	5,758	650	10,972	1,239
PH721F0100K102VF0230MT10	232.7	11400/49	4,000	4,000	6,000	3.5	0.69	881	99	2,657	300	4,429	500	8,858	1,000
PH721F0100K102VF0230MT20	232.7	11400/49	3,500	3,500	5,000	3.5	1.29	881	100	2,657	300	4,429	500	8,858	1,000
PH721F0070K102VF0340MT10	235.9	4719/20	4,000	4,000	6,000	4	0.63	954	108	3,898	440	5,214	589	9,429	1,064
PH721F0070K102VF0350MT10	245.7	3686/15	4,000	4,000	6,000	4	0.64	954	108	3,898	440	5,758	650	10,972	1,239
PH721F0070K102VF0350MT20	245.7	3686/15	3,500	3,500	5,000	4	1.24	954	108	3,898	440	5,758	650	10,972	1,239
PH721F0100K102VF0280MT10	280.5	5890/21	4,000	4,000	6,000	3.5	0.67	882	100	2,657	300	4,429	500	8,858	1,000
PH721F0100K102VF0280MT20	280.5	5890/21	3,500	3,500	5,000	3.5	1.27	882	100	2,657	300	4,429	500	8,858	1,000
PH721F0070K102VF0400MT10	282.1	2821/10	4,000	4,000	6,000	4	0.62	955	108	3,635	410	3,635	410	4,931	557
PH721F0070K102VF0470MT10	328.4	2299/7	4,000	4,000	6,000	4	0.63	955	108	3,898	440	5,758	650	10,972	1,239
PH721F0100K102VF0350MT10	351.1	7372/21	4,000	4,000	6,000	3.5	0.64	883	100	2,657	300	4,429	500	8,858	1,000
PH721F0100K102VF0350MT20	351.1	7372/21	3,500	3,500	5,000	3.5	1.24	883	100	2,657	300	4,429	500	8,858	1,000
PH721F0070K102VF0500MT10	352.2	35217/100	4,000	4,000	6,000	4	0.62	956	108	2,973	336	3,567	403	5,304	599
PH721F0070K102VF0560MT10	392.7	1178/3	4,000	4,000	6,000	4	0.62	956	108	3,898	440	5,060	571	6,864	775
PH721F0100K102VF0470MT10	469.2	22990/49	4,000	4,000	6,000	3.5	0.63	883	100	2,657	300	4,429	500	8,858	1,000
PH721F0070K102VF0700MT10	490.2	2451/5	4,000	4,000	6,000	4	0.61	956	108	3,898	440	4,966	561	7,382	833
PH721F0100K102VF0560MT10	561.0	11780/21	4,000	4,000	6,000	3.5	0.62	884	100	2,657	300	4,429	500	8,858	1,000
PH721_K202 with Motor Mounting Plate <i>Continued Next Page</i>															
PH721F0040K202VF0040MT10	16.00	16/1	3,000	2,600	4,000	4.5	3.29	482	54	1,584	179	1,584	179	2,148	243
PH721F0040K202VF0040MT20	16.00	16/1	3,000	2,600	4,000	4.5	3.89	501	57	3,513	397	5,807	656	9,238	1,043
PH721F0040K202VF0040MT30	16.00	16/1	3,000	2,600	4,000	4.5	8.69	582	66	3,513	397	5,935	670	10,740	1,213
PH721F0050K202VF0040MT10	20.00	20/1	3,000	2,600	4,000	4	3.18	645	73	1,980	223	1,980	223	2,685	303
PH721F0050K202VF0040MT20	20.00	20/1	3,000	2,600	4,000	4	3.78	666	75	3,898	440	6,201	700	11,548	1,304
PH721F0050K202VF0040MT30	20.00	20/1	3,000	2,600	4,000	4	8.58	756	85	3,898	440	6,201	700	12,401	1,400
PH721F0050K202VF0052MT20	25.89	10535/407	3,000	2,600	4,000	4	2.93	761	86	3,898	440	6,201	700	12,401	1,400
PH721F0050K202VF0052MT30	25.89	10535/407	3,000	2,600	4,000	4	7.73	828	93	3,898	440	6,201	700	12,401	1,400

¹⁾ Maximum torque for continuous input RPM - horizontal output position.
²⁾ Maximum momentary torque for emergency stops or heavy shock load.
 Admissible stops per life of reducer = 1,000 stops maximum.

Index of Symbols

i	... Exact Ratio = Exact Tooth Count
J ₁	... Reducer Inertia
C ₂	... Torsional Stiffness
n _{1DBH}	... Maximum Continuous Input RPM Horizontal Mounting - EL1, 2, 5, 6
n _{1DBV}	... Maximum Continuous Input RPM Vertical Position - EL3 and EL4
n _{1ZB}	... Maximum Cyclic Input RPM
M _{2N}	... Nominal Torque @ 2000 RPM Input
M _{2B}	... Acceleration Torque Maximum
M _{2PEAK}	... Peak Torque



"PHK" Series – Right Angle ServoFit® Precision Planetary Gearhead Selection Data



Part Number	Reducer Ratio i		Input RPM			Backlash arcmins $\Delta\phi$	Input Inertia J ₁ kgcm ²	Torsional Stiffness per arcmin		Output Torque					
			Maximum					C ₂ in.lbs. Nm	Nominal ¹⁾		Acceleration		Peak ²⁾		
	Nom.	Exact	n _{1DBH}	n _{1DBV}	n _{1ZB}	M _{2N ≤ 2000 RPM} in.lbs. Nm	M _{2B} in.lbs. Nm		M _{2PEAK} in.lbs. Nm						
								Continuous	Cyclic	in.lbs.	Nm	in.lbs.	Nm		
PH721_K202 with Motor Mounting Plate <i>Continued</i>															
PH721F0050K202VF0060MT10	30.00	30/1	3,000	2,600	4,000	4	2.36	790	89	2,969	335	2,969	335	4,028	455
PH721F0050K202VF0060MT20	30.00	30/1	3,000	2,600	4,000	4	2.96	804	91	3,898	440	6,201	700	12,401	1,400
PH721F0050K202VF0060MT30	30.00	30/1	3,000	2,600	4,000	4	7.76	859	97	3,898	440	6,201	700	12,401	1,400
PH721F0050K202VF0067MT10	33.42	11395/341	3,500	3,100	4,500	4	1.75	818	92	3,308	373	3,308	373	4,486	506
PH721F0050K202VF0067MT20	33.42	11395/341	3,500	3,100	4,500	4	2.35	831	94	3,898	440	6,201	700	12,401	1,400
PH721F0050K202VF0067MT30	33.42	11395/341	3,500	3,100	4,000	4	7.15	877	99	3,898	440	6,201	700	12,401	1,400
PH721F0050K202VF0084MT10	41.99	12470/297	3,500	3,100	4,500	4	1.41	866	98	3,898	440	4,156	469	5,637	636
PH721F0050K202VF0084MT20	41.99	12470/297	3,500	3,100	4,500	4	2.01	875	99	3,898	440	6,201	700	12,401	1,400
PH721F0050K202VF0084MT30	41.99	12470/297	3,500	3,100	4,000	4	6.81	907	102	3,898	440	6,201	700	12,401	1,400
PH721F0050K202VF0092MT10	45.95	11395/248	3,500	3,100	4,500	4	1.55	881	99	3,898	440	4,548	513	6,169	696
PH721F0050K202VF0092MT20	45.95	11395/248	3,500	3,100	4,500	4	2.15	888	100	3,898	440	6,201	700	12,401	1,400
PH721F0050K202VF0092MT30	45.95	11395/248	3,500	3,100	4,000	4	6.95	916	103	3,898	440	6,201	700	12,401	1,400
PH721F0050K202VF0115MT10	57.73	6235/108	3,500	3,100	4,500	4	1.28	909	103	3,898	440	5,714	645	7,750	875
PH721F0050K202VF0115MT20	57.73	6235/108	3,500	3,100	4,500	4	1.88	915	103	3,898	440	6,201	700	12,401	1,400
PH721F0050K202VF0115MT30	57.73	6235/108	3,500	3,100	4,000	4	6.68	933	105	3,898	440	6,201	700	12,401	1,400
PH721F0050K202VF0140MT10	69.26	14405/208	3,900	3,500	5,000	4	1.12	925	104	3,898	440	6,201	700	9,298	1,050
PH721F0050K202VF0140MT20	69.26	14405/208	3,500	3,500	5,000	4	1.72	929	105	3,898	440	6,201	700	12,401	1,400
PH721F0050K202VF0140MT30	69.26	14405/208	3,500	3,500	4,000	4	6.52	942	106	3,898	440	6,201	700	12,401	1,400
PH721F0050K202VF0175MT10	87.35	2795/32	3,900	3,500	5,000	4	0.97	939	106	3,898	440	6,201	700	11,726	1,324
PH721F0050K202VF0175MT20	87.35	2795/32	3,500	3,500	5,000	4	1.57	941	106	3,898	440	6,201	700	12,401	1,400
PH721F0050K202VF0175MT30	87.35	2795/32	3,500	3,500	4,000	4	6.37	950	107	3,898	440	6,201	700	12,401	1,400
PH721F0050K202VF0230MT10	115.9	14835/128	4,000	3,900	5,500	4	0.84	949	107	3,898	440	6,201	700	12,401	1,400
PH721F0050K202VF0230MT20	115.9	14835/128	3,500	3,500	5,000	4	1.44	951	107	3,898	440	6,201	700	12,401	1,400
PH721F0050K202VF0230MT30	115.9	14835/128	3,500	3,500	4,000	4	6.24	956	108	3,898	440	6,201	700	12,401	1,400
PH721F0050K202VF0280MT10	139.8	559/4	4,000	3,900	5,500	4	0.78	954	108	3,898	440	6,201	700	12,401	1,400
PH721F0050K202VF0280MT20	139.8	559/4	3,500	3,500	5,000	4	1.38	955	108	3,898	440	6,201	700	12,401	1,400
PH721F0050K202VF0280MT30	139.8	559/4	3,500	3,500	4,000	4	6.18	958	108	3,898	440	6,201	700	12,401	1,400
PH721F0050K202VF0350MT10	172.8	9675/56	4,000	3,900	5,500	4	0.72	957	108	3,898	440	6,201	700	12,401	1,400
PH721F0050K202VF0350MT20	172.8	9675/56	3,500	3,500	5,000	4	1.32	958	108	3,898	440	6,201	700	12,401	1,400
PH721F0050K202VF0350MT30	172.8	9675/56	3,500	3,500	4,000	4	6.12	960	108	3,898	440	6,201	700	12,401	1,400
PH721F0050K202VF0460MT10	231.1	1849/8	4,000	3,900	5,500	4	0.67	960	108	3,898	440	6,201	700	12,401	1,400
PH721F0050K202VF0460MT20	231.1	1849/8	3,500	3,500	5,000	4	1.27	960	108	3,898	440	6,201	700	12,401	1,400
PH721F0050K202VF0560MT10	277.7	6665/24	4,000	3,900	5,500	4	0.65	961	108	3,898	440	6,201	700	12,401	1,400

PHK

Max. Motor Shaft Diameter

Adapter	Shaft	Adapter	Shaft	Adapter	Shaft
MT10	19	MT30	38	MT50	60
MT20	24	MT40	48		

See Page 116 for Options and Part Number Configuration.



"PHK" Series – Right Angle ServoFit® Precision Planetary Gearhead Selection Data



PHK

Part Number	Reducer Ratio i		Input RPM			Backlash arcmins Δφ	Input Inertia J ₁ kgcm ²	Torsional Stiffness per arcmin C ₂		Output Torque					
			Maximum		Nominal ¹⁾ M _{2N} ≤ 2000 RPM					Acceleration		Peak ²⁾			
	Nom.	Exact	n _{1DBH}	n _{1DBV}		n _{1ZB}	M _{2N}	M _{2B}	M _{2PEAK}						
						in.lbs.	Nm	in.lbs.	Nm	in.lbs.	Nm				
PH821_K202 with Motor Mounting Plate Continued Next Page															
PH821F0070K202VF0040MT10	28.00	28/1	3,000	2,600	4,000	3,5	3.48	1,382	156	2,772	313	2,772	313	3,759	424
PH821F0070K202VF0040MT20	28.00	28/1	3,000	2,600	4,000	3,5	4.08	1,433	162	6,148	694	10,162	1,147	16,167	1,825
PH821F0070K202VF0040MT30	28.00	28/1	3,000	2,600	4,000	3,5	8.88	1,646	186	6,148	694	10,386	1,173	18,796	2,122
PH821F0070K202VF0044MT10	30.55	336/11	3,000	2,600	4,000	3,5	3.08	1,466	166	3,024	341	3,024	341	4,101	463
PH821F0070K202VF0044MT20	30.55	336/11	3,000	2,600	4,000	3,5	3.68	1,515	171	6,329	715	10,692	1,207	17,638	1,991
PH821F0070K202VF0044MT30	30.55	336/11	3,000	2,600	4,000	3,5	8.48	1,712	193	6,329	715	10,692	1,207	20,506	2,315
PH821F0070K202VF0052MT20	36.24	14749/407	3,000	2,600	4,000	3,5	3.11	1,659	187	6,700	756	11,319	1,278	20,924	2,362
PH821F0070K202VF0052MT30	36.24	14749/407	3,000	2,600	4,000	3,5	7.91	1,822	206	6,700	756	11,319	1,278	24,326	2,746
PH821F0100K202VF0040MT10	40.00	40/1	3,000	2,600	4,000	3,5	3.24	1,687	190	3,959	447	3,959	447	5,370	606
PH821F0100K202VF0040MT20	40.00	40/1	3,000	2,600	4,000	3,5	3.84	1,724	195	7,086	800	10,630	1,200	21,259	2,400
PH821F0100K202VF0040MT30	40.00	40/1	3,000	2,600	4,000	3,5	8.64	1,867	211	7,086	800	10,630	1,200	21,259	2,400
PH821F0070K202VF0060MT10	42.00	42/1	3,000	2,600	4,000	3,5	2.49	1,729	195	4,157	469	4,157	469	5,639	637
PH821F0070K202VF0060MT20	42.00	42/1	3,000	2,600	4,000	3,5	3.09	1,764	199	7,038	795	11,890	1,342	24,251	2,738
PH821F0070K202VF0060MT30	42.00	42/1	3,000	2,600	4,000	3,5	7.89	1,899	214	7,038	795	11,890	1,342	24,536	2,770
PH821F0070K202VF0067MT10	46.78	15953/341	3,500	3,100	4,500	3,5	1.86	1,799	203	4,631	523	4,631	523	6,281	709
PH821F0070K202VF0067MT20	46.78	15953/341	3,500	3,100	4,500	3,5	2.46	1,830	207	7,295	824	12,325	1,391	24,536	2,770
PH821F0070K202VF0067MT30	46.78	15953/341	3,500	3,100	4,000	3,5	7.26	1,945	220	7,295	824	12,325	1,391	24,536	2,770
PH821F0070K202VF0071MT20	49.83	14749/296	3,000	2,600	4,000	3,5	2.69	1,864	210	7,450	841	12,586	1,421	24,536	2,770
PH821F0070K202VF0071MT30	49.83	14749/296	3,000	2,600	4,000	3,5	7.49	1,969	222	7,450	841	12,586	1,421	24,536	2,770
PH821F0100K202VF0052MT20	51.77	21070/407	3,000	2,600	4,000	3,5	2.96	1,874	212	7,086	800	10,630	1,200	21,259	2,400
PH821F0100K202VF0052MT30	51.77	21070/407	3,000	2,600	4,000	3,5	7.76	1,972	223	7,086	800	10,630	1,200	21,259	2,400
PH821F0070K202VF0084MT10	58.78	17458/297	3,500	3,100	4,500	3,5	1.48	1,918	217	5,818	657	5,818	657	7,891	891
PH821F0070K202VF0084MT20	58.78	17458/297	3,500	3,100	4,500	3,5	2.08	1,940	219	7,872	889	13,096	1,478	24,536	2,770
PH821F0070K202VF0084MT30	58.78	17458/297	3,500	3,100	4,000	3,5	6.88	2,020	228	7,872	889	13,096	1,478	24,536	2,770
PH821F0100K202VF0060MT10	60.00	60/1	3,000	2,600	4,000	3,5	2.39	1,918	216	5,939	670	5,939	670	8,055	909
PH821F0100K202VF0060MT20	60.00	60/1	3,000	2,600	4,000	3,5	2.99	1,938	219	7,086	800	10,630	1,200	21,259	2,400
PH821F0100K202VF0060MT30	60.00	60/1	3,000	2,600	4,000	3,5	7.79	2,015	228	7,086	800	10,630	1,200	21,259	2,400
PH821F0070K202VF0092MT10	64.33	15953/248	3,500	3,100	4,500	3,5	1.61	1,955	221	6,368	719	6,368	719	8,637	975
PH821F0070K202VF0092MT20	64.33	15953/248	3,500	3,100	4,500	3,5	2.21	1,974	223	8,113	916	13,096	1,478	24,536	2,770
PH821F0070K202VF0092MT30	64.33	15953/248	3,500	3,100	4,000	3,5	7.01	2,043	231	8,113	916	13,096	1,478	24,536	2,770
PH821F0100K202VF0067MT10	66.83	22790/341	3,500	3,100	4,500	3,5	1.77	1,959	221	6,615	747	6,615	747	8,972	1,013
PH821F0100K202VF0067MT20	66.83	22790/341	3,500	3,100	4,500	3,5	2.37	1,977	223	7,086	800	10,630	1,200	21,259	2,400
PH821F0100K202VF0067MT30	66.83	22790/341	3,500	3,100	4,000	3,5	7.17	2,041	230	7,086	800	10,630	1,200	21,259	2,400
PH821F0070K202VF0100MT10	70.51	20167/286	3,900	3,500	5,000	3,5	1.25	1,987	224	6,979	788	6,979	788	9,466	1,069
PH821F0070K202VF0100MT20	70.51	20167/286	3,500	3,500	5,000	3,5	1.85	2,003	226	8,365	944	13,096	1,478	24,536	2,770
PH821F0070K202VF0100MT30	70.51	20167/286	3,500	3,500	4,000	3,5	6.65	2,062	233	8,365	944	13,096	1,478	24,536	2,770

¹⁾ Maximum torque for continuous input RPM - horizontal output position.
²⁾ Maximum momentary torque for emergency stops or heavy shock load.
 Admissible stops per life of reducer = 1,000 stops maximum.

Index of Symbols

i	... Exact Ratio = Exact Tooth Count
J ₁	... Reducer Inertia
C ₂	... Torsional Stiffness
n _{1DBH}	... Maximum Continuous Input RPM Horizontal Mounting - EL1, 2, 5, 6
n _{1DBV}	... Maximum Continuous Input RPM Vertical Position - EL3 and EL4
n _{1ZB}	... Maximum Cyclic Input RPM
M _{2N}	... Nominal Torque @ 2000 RPM Input
M _{2B}	... Acceleration Torque Maximum
M _{2PEAK}	... Peak Torque



"PHK" Series – Right Angle ServoFit® Precision Planetary Gearhead Selection Data



Part Number	Reducer Ratio i		Input RPM				Backlash arcmins $\Delta\phi$	Input Inertia J ₁ kgcm ²	Torsional Stiffness per arcmin C ₂ in.lbs. Nm		Output Torque					
			Maximum		n _{1DBH}	n _{1DBV}					n _{1ZB}	Nominal ¹⁾		Acceleration		Peak ²⁾
	Continuous	Cyclic	M _{2N ≤ 2000 RPM}				M _{2B}		M _{2PEAK}							
	Nom.	Exact	n _{1DBH}	n _{1DBV}	n _{1ZB}	$\Delta\phi$	kgcm ²	in.lbs.	Nm	in.lbs.	Nm	in.lbs.	Nm	in.lbs.	Nm	
PH821_K202 with Motor Mounting Plate Continued Next Page																
PH821F0070K202VF0115MT10	80.82	8729/108	3,500	3,100	4,500	3,5	1.32	2,027	229	8,000	903	8,000	903	10,851	1,225	
PH821F0070K202VF0115MT20	80.82	8729/108	3,500	3,100	4,500	3,5	1.92	2,040	230	8,754	988	13,096	1,478	24,536	2,770	
PH821F0070K202VF0115MT30	80.82	8729/108	3,500	3,100	4,000	3,5	6.72	2,086	235	8,754	988	13,096	1,478	24,536	2,770	
PH821F0100K202VF0084MT10	83.97	24940/297	3,500	3,100	4,500	3,5	1.42	2,026	229	7,086	800	8,312	938	11,273	1,273	
PH821F0100K202VF0084MT20	83.97	24940/297	3,500	3,100	4,500	3,5	2.02	2,038	230	7,086	800	10,630	1,200	21,259	2,400	
PH821F0100K202VF0084MT30	83.97	24940/297	3,500	3,100	4,000	3,5	6.82	2,080	235	7,086	800	10,630	1,200	21,259	2,400	
PH821F0070K202VF0125MT10	88.94	3913/44	3,900	3,500	5,000	3,5	1.05	2,050	231	8,803	994	8,803	994	11,940	1,348	
PH821F0070K202VF0125MT20	88.94	3913/44	3,500	3,500	5,000	3,5	1.65	2,060	233	8,858	1,000	13,096	1,478	24,536	2,770	
PH821F0070K202VF0125MT30	88.94	3913/44	3,500	3,500	4,000	3,5	6.45	2,099	237	8,858	1,000	13,096	1,478	24,536	2,770	
PH821F0100K202VF0092MT10	91.90	11395/124	3,500	3,100	4,500	3,5	1.56	2,046	231	7,086	800	9,097	1,027	12,338	1,393	
PH821F0100K202VF0092MT20	91.90	11395/124	3,500	3,100	4,500	3,5	2.16	2,056	232	7,086	800	10,630	1,200	21,259	2,400	
PH821F0100K202VF0092MT30	91.90	11395/124	3,500	3,100	4,000	3,5	6.96	2,092	236	7,086	800	10,630	1,200	21,259	2,400	
PH821F0070K202VF0140MT10	96.96	20167/208	3,900	3,500	5,000	3,5	1.14	2,067	233	8,858	1,000	9,597	1,083	13,017	1,470	
PH821F0070K202VF0140MT20	96.96	20167/208	3,500	3,500	5,000	3,5	1.74	2,076	234	8,858	1,000	13,096	1,478	24,536	2,770	
PH821F0070K202VF0140MT30	96.96	20167/208	3,500	3,500	4,000	3,5	6.54	2,109	238	8,858	1,000	13,096	1,478	24,536	2,770	
PH821F0100K202VF0115MT10	115.5	6235/54	3,500	3,100	4,500	3,5	1.29	2,084	235	7,086	800	10,630	1,200	15,501	1,750	
PH821F0100K202VF0115MT20	115.5	6235/54	3,500	3,100	4,500	3,5	1.89	2,090	236	7,086	800	10,630	1,200	21,259	2,400	
PH821F0100K202VF0115MT30	115.5	6235/54	3,500	3,100	4,000	3,5	6.69	2,114	239	7,086	800	10,630	1,200	21,259	2,400	
PH821F0070K202VF0170MT10	118.0	20769/176	4,000	3,900	5,500	3,5	0.89	2,098	237	8,858	1,000	11,681	1,319	15,843	1,789	
PH821F0070K202VF0170MT20	118.0	20769/176	3,500	3,500	5,000	3,5	1.49	2,104	238	8,858	1,000	13,096	1,478	24,536	2,770	
PH821F0070K202VF0170MT30	118.0	20769/176	3,500	3,500	4,000	3,5	6.29	2,127	240	8,858	1,000	13,096	1,478	24,536	2,770	
PH821F0070K202VF0175MT10	122.3	3913/32	3,900	3,500	5,000	3,5	0.98	2,102	237	8,858	1,000	12,104	1,366	16,417	1,853	
PH821F0070K202VF0175MT20	122.3	3913/32	3,500	3,500	5,000	3,5	1.58	2,108	238	8,858	1,000	13,096	1,478	24,536	2,770	
PH821F0070K202VF0175MT30	122.3	3913/32	3,500	3,500	4,000	3,5	6.38	2,130	240	8,858	1,000	13,096	1,478	24,536	2,770	
PH821F0100K202VF0140MT10	138.5	14405/104	3,900	3,500	5,000	3,5	1.12	2,104	238	7,086	800	10,630	1,200	18,596	2,099	
PH821F0100K202VF0140MT20	138.5	14405/104	3,500	3,500	5,000	3,5	1.72	2,109	238	7,086	800	10,630	1,200	21,259	2,400	
PH821F0100K202VF0140MT30	138.5	14405/104	3,500	3,500	4,000	3,5	6.52	2,126	240	7,086	800	10,630	1,200	21,259	2,400	
PH821F0070K202VF0200MT10	142.3	7826/55	4,000	3,900	5,500	3,5	0.81	2,118	239	8,858	1,000	13,096	1,478	17,798	2,009	
PH821F0070K202VF0200MT20	142.3	7826/55	3,500	3,500	5,000	3,5	1.41	2,123	240	8,858	1,000	13,096	1,478	24,536	2,770	
PH821F0070K202VF0200MT30	142.3	7826/55	3,500	3,500	4,000	3,5	6.21	2,139	241	8,858	1,000	13,096	1,478	24,536	2,770	
PH821F0070K202VF0230MT10	162.3	20769/128	4,000	3,900	5,500	3,5	0.85	2,129	240	8,858	1,000	13,096	1,478	21,784	2,459	
PH821F0070K202VF0230MT20	162.3	20769/128	3,500	3,500	5,000	3,5	1.45	2,132	241	8,858	1,000	13,096	1,478	24,536	2,770	
PH821F0070K202VF0230MT30	162.3	20769/128	3,500	3,500	4,000	3,5	6.25	2,145	242	8,858	1,000	13,096	1,478	24,536	2,770	
PH821F0100K202VF0175MT10	174.7	2795/16	3,900	3,500	5,000	3,5	0.97	2,122	240	7,086	800	10,630	1,200	21,259	2,400	
PH821F0100K202VF0175MT20	174.7	2795/16	3,500	3,500	5,000	3,5	1.57	2,125	240	7,086	800	10,630	1,200	21,259	2,400	
PH821F0100K202VF0175MT30	174.7	2795/16	3,500	3,500	4,000	3,5	6.37	2,136	241	7,086	800	10,630	1,200	21,259	2,400	

PHK

Max. Motor Shaft Diameter

Adapter	Shaft	Adapter	Shaft	Adapter	Shaft
MT10	19	MT30	38	MT50	60
MT20	24	MT40	48		

See Page 116 for Options and Part Number Configuration.



"PHK" Series – Right Angle ServoFit® Precision Planetary Gearhead Selection Data



PHK

Part Number	Reducer Ratio i		Input RPM			Backlash arcmins $\Delta\phi$	Input Inertia J ₁ kgcm ²	Torsional Stiffness per arcmin C ₂		Output Torque					
			Maximum		Nominal ¹⁾ M _{2N} ≤ 2000 RPM					Acceleration		Peak ²⁾			
	Continuous	Cyclic						M _{2B}		M _{2PEAK}					
	Nom.	Exact	n _{1DBH}	n _{1DBV}	n _{1ZB}			in.lbs.	Nm	in.lbs.	Nm	in.lbs.	Nm		
PH821_K202 with Motor Mounting Plate <i>Continued</i>															
PH821F0070K202VF0250MT10	175.9	1935/11	4,000	3,900	5,500	3,5	0.75	2,134	241	8,858	1,000	13,096	1,478	19,460	2,197
PH821F0070K202VF0250MT20	175.9	1935/11	3,500	3,500	5,000	3,5	1.35	2,137	241	8,858	1,000	13,096	1,478	24,536	2,770
PH821F0070K202VF0250MT30	175.9	1935/11	3,500	3,500	4,000	3,5	6.15	2,148	242	8,858	1,000	13,096	1,478	24,536	2,770
PH821F0070K202VF0280MT10	195.7	3913/20	4,000	3,900	5,500	3,5	0.78	2,140	242	8,858	1,000	13,096	1,478	24,472	2,763
PH821F0070K202VF0280MT20	195.7	3913/20	3,500	3,500	5,000	3,5	1.38	2,142	242	8,858	1,000	13,096	1,478	24,536	2,770
PH821F0070K202VF0280MT30	195.7	3913/20	3,500	3,500	4,000	3,5	6.18	2,151	243	8,858	1,000	13,096	1,478	24,536	2,770
PH821F0100K202VF0230MT10	231.8	14835/64	4,000	3,900	5,500	3,5	0.84	2,135	241	7,086	800	10,630	1,200	21,259	2,400
PH821F0100K202VF0230MT20	231.8	14835/64	3,500	3,500	5,000	3,5	1.44	2,137	241	7,086	800	10,630	1,200	21,259	2,400
PH821F0100K202VF0230MT30	231.8	14835/64	3,500	3,500	4,000	3,5	6.24	2,143	242	7,086	800	10,630	1,200	21,259	2,400
PH821F0070K202VF0340MT10	235.3	12943/55	4,000	3,900	5,500	3,5	0.69	2,147	242	8,858	1,000	11,001	1,242	19,896	2,246
PH821F0070K202VF0340MT20	235.3	12943/55	3,500	3,500	5,000	3,5	1.29	2,149	243	8,858	1,000	11,001	1,242	19,896	2,246
PH821F0070K202VF0350MT10	241.9	1935/8	4,000	3,900	5,500	3,5	0.73	2,148	243	8,858	1,000	13,096	1,478	24,536	2,770
PH821F0070K202VF0350MT20	241.9	1935/8	3,500	3,500	5,000	3,5	1.33	2,150	243	8,858	1,000	13,096	1,478	24,536	2,770
PH821F0070K202VF0350MT30	241.9	1935/8	3,500	3,500	4,000	3,5	6.13	2,156	243	8,858	1,000	13,096	1,478	24,536	2,770
PH821F0100K202VF0280MT10	279.5	559/2	4,000	3,900	5,500	3,5	0.78	2,141	242	7,086	800	10,630	1,200	21,259	2,400
PH821F0100K202VF0280MT20	279.5	559/2	3,500	3,500	5,000	3,5	1.38	2,142	242	7,086	800	10,630	1,200	21,259	2,400
PH821F0100K202VF0280MT30	279.5	559/2	3,500	3,500	4,000	3,5	6.18	2,146	242	7,086	800	10,630	1,200	21,259	2,400
PH821F0070K202VF0400MT10	282.8	9331/33	4,000	3,900	5,500	3,5	0.66	2,153	243	6,876	776	8,251	931	12,770	1,442
PH821F0070K202VF0460MT10	323.6	12943/40	4,000	3,900	5,500	3,5	0.68	2,156	243	8,858	1,000	13,096	1,478	24,536	2,770
PH821F0070K202VF0460MT20	323.6	12943/40	3,500	3,500	5,000	3,5	1.28	2,156	243	8,858	1,000	13,096	1,478	24,536	2,770
PH821F0100K202VF0350MT10	345.5	9675/28	4,000	3,900	5,500	3,5	0.73	2,145	242	7,086	800	10,630	1,200	21,259	2,400
PH821F0100K202VF0350MT20	345.5	9675/28	3,500	3,500	5,000	3,5	1.33	2,146	242	7,086	800	10,630	1,200	21,259	2,400
PH821F0100K202VF0350MT30	345.5	9675/28	3,500	3,500	4,000	3,5	6.13	2,148	243	7,086	800	10,630	1,200	21,259	2,400
PH821F0070K202VF0500MT10	353.4	46655/132	4,000	3,900	5,500	3,5	0.64	2,157	244	5,730	647	6,876	776	12,169	1,374
PH821F0070K202VF0560MT10	388.8	9331/24	4,000	3,900	5,500	3,5	0.66	2,158	244	8,858	1,000	11,345	1,281	17,559	1,982
PH821F0100K202VF0460MT10	462.3	1849/4	4,000	3,900	5,500	3,5	0.68	2,148	243	7,086	800	10,630	1,200	21,259	2,400
PH821F0100K202VF0460MT20	462.3	1849/4	3,500	3,500	5,000	3,5	1.28	2,149	243	7,086	800	10,630	1,200	21,259	2,400
PH821F0070K202VF0690MT10	486.0	46655/96	4,000	3,900	5,500	3,5	0.64	2,161	244	7,879	889	9,455	1,067	16,732	1,889
PH821F0100K202VF0560MT10	555.4	6665/12	4,000	3,900	5,500	3,5	0.65	2,150	243	7,086	800	10,630	1,200	21,259	2,400

¹⁾ Maximum torque for continuous input RPM - horizontal output position.
²⁾ Maximum momentary torque for emergency stops or heavy shock load.
 Admissible stops per life of reducer = 1,000 stops maximum.

Index of Symbols

i	... Exact Ratio = Exact Tooth Count
J ₁	... Reducer Inertia
C ₂	... Torsional Stiffness
n _{1DBH}	... Maximum Continuous Input RPM Horizontal Mounting - EL1, 2, 5, 6
n _{1DBV}	... Maximum Continuous Input RPM Vertical Position - EL3 and EL4
n _{1ZB}	... Maximum Cyclic Input RPM
M _{2N}	... Nominal Torque @ 2000 RPM Input
M _{2B}	... Acceleration Torque Maximum
M _{2PEAK}	... Peak Torque



"PHK" Series – Right Angle ServoFit® Precision Planetary Gearhead Selection Data



Part Number	Reducer Ratio		Input RPM				Backlash arcmins	Input Inertia J ₁	Torsional Stiffness per arcmin		Output Torque					
			Maximum			Cyclic					Nominal ¹⁾	Acceleration		Peak ²⁾		
	Nom.	Exact	n _{1DBH}	n _{1DBV}	n _{1ZB}		C ₂	M _{2N} ≤ 2000 RPM		M _{2B}		M _{2PEAK}				
						in.lbs.		Nm	in.lbs.	Nm	in.lbs.	Nm				
PH821_K302 with Motor Mounting Plate																
PH821F0040K302VF0040MT20	16.00	16/1	2,700	2,300	3,800	4	7.67	747	84	5,279	596	5,807	656	9,238	1,043	
PH821F0040K302VF0040MT30	16.00	16/1	2,700	2,300	3,800	4	12.47	942	106	6,153	695	10,395	1,174	20,446	2,308	
PH821F0050K302VF0040MT20	20.00	20/1	2,700	2,300	3,800	4	7.11	1,062	120	6,599	745	7,259	819	11,548	1,304	
PH821F0050K302VF0040MT30	20.00	20/1	2,700	2,300	3,800	4	11.91	1,309	148	7,691	868	12,994	1,467	25,418	2,870	
PH821F0050K302VF0054MT20	26.88	215/8	2,700	2,300	3,800	4	4.91	1,360	154	8,488	958	9,754	1,101	15,518	1,752	
PH821F0050K302VF0054MT30	26.88	215/8	2,700	2,300	3,800	4	9.71	1,570	177	8,488	958	13,301	1,502	18,040	2,037	
PH821F0050K302VF0060MT20	30.00	30/1	2,700	2,300	3,800	4	5.11	1,460	165	8,804	994	10,888	1,229	17,322	1,956	
PH821F0050K302VF0060MT30	30.00	30/1	2,700	2,300	3,800	4	9.91	1,651	186	8,804	994	14,874	1,679	28,346	3,200	
PH821F0050K302VF0074MT20	36.96	2365/64	2,700	2,300	3,800	4	4.11	1,627	184	8,858	1,000	13,412	1,514	21,338	2,409	
PH821F0050K302VF0074MT30	36.96	2365/64	2,700	2,300	3,800	4	8.91	1,777	201	8,858	1,000	15,945	1,800	24,807	2,800	
PH821F0050K302VF0093MT20	46.34	5375/116	3,200	2,800	4,200	4	3.28	1,769	200	8,858	1,000	16,370	1,848	25,418	2,870	
PH821F0050K302VF0093MT30	46.34	5375/116	3,200	2,800	4,000	4	8.08	1,879	212	8,858	1,000	16,370	1,848	28,346	3,200	
PH821F0050K302VF0115MT20	58.05	1161/20	3,200	2,800	4,200	4	2.69	1,873	211	8,858	1,000	16,370	1,848	28,346	3,200	
PH821F0050K302VF0115MT30	58.05	1161/20	3,200	2,800	4,000	4	7.49	1,950	220	8,858	1,000	16,370	1,848	25,418	2,870	
PH821F0050K302VF0140MT20	69.68	7525/108	3,500	3,100	5,000	4	2.31	1,933	218	8,858	1,000	16,370	1,848	25,418	2,870	
PH821F0050K302VF0140MT30	69.68	7525/108	3,500	3,100	4,000	4	7.11	1,990	225	8,858	1,000	16,370	1,848	25,418	2,870	
PH821F0050K302VF0175MT10	86.47	7955/92	3,500	3,100	5,000	4	1.40	1,974	223	8,559	966	8,559	966	11,608	1,310	
PH821F0050K302VF0175MT20	86.47	7955/92	3,500	3,100	5,000	4	2.00	1,985	224	8,858	1,000	16,370	1,848	28,346	3,200	
PH821F0050K302VF0175MT30	86.47	7955/92	3,500	3,100	4,000	4	6.80	2,023	228	8,858	1,000	16,370	1,848	28,346	3,200	
PH821F0050K302VF0230MT10	116.5	2795/24	3,800	3,500	5,000	4	1.11	2,023	228	8,858	1,000	11,528	1,301	15,635	1,765	
PH821F0050K302VF0230MT20	116.5	2795/24	3,500	3,500	5,000	4	1.71	2,029	229	8,858	1,000	16,370	1,848	28,346	3,200	
PH821F0050K302VF0230MT30	116.5	2795/24	3,500	3,500	4,000	4	6.51	2,051	232	8,858	1,000	16,370	1,848	25,418	2,870	
PH821F0050K302VF0280MT10	139.4	17845/128	3,800	3,500	5,000	4	0.98	2,042	231	8,858	1,000	13,800	1,558	18,717	2,113	
PH821F0050K302VF0280MT20	139.4	17845/128	3,500	3,500	5,000	4	1.58	2,047	231	8,858	1,000	16,370	1,848	28,346	3,200	
PH821F0050K302VF0280MT30	139.4	17845/128	3,500	3,500	4,000	4	6.38	2,062	233	8,858	1,000	16,370	1,848	25,418	2,870	
PH821F0050K302VF0350MT10	173.7	4515/26	3,800	3,500	5,000	4	0.87	2,058	232	8,858	1,000	14,498	1,637	19,664	2,220	
PH821F0050K302VF0350MT20	173.7	4515/26	3,500	3,500	5,000	4	1.47	2,061	233	8,858	1,000	16,370	1,848	28,346	3,200	
PH821F0050K302VF0350MT30	173.7	4515/26	3,500	3,500	4,000	4	6.27	2,071	234	8,858	1,000	16,370	1,848	28,346	3,200	
PH821F0050K302VF0460MT10	231.1	1849/8	3,800	3,500	5,000	4	0.76	2,071	234	8,858	1,000	16,370	1,848	23,475	2,650	
PH821F0050K302VF0460MT20	231.1	1849/8	3,500	3,500	5,000	4	1.36	2,072	234	8,858	1,000	16,370	1,848	25,418	2,870	
PH821F0050K302VF0460MT30	231.1	1849/8	3,500	3,500	4,000	4	6.16	2,078	235	8,858	1,000	16,370	1,848	28,346	3,200	
PH821F0050K302VF0560MT10	278.5	12255/44	3,800	3,500	5,000	4	0.72	2,076	234	8,858	1,000	13,507	1,525	24,426	2,757	
PH821F0050K302VF0560MT20	278.5	12255/44	3,500	3,500	5,000	4	1.32	2,077	234	8,858	1,000	13,507	1,525	24,426	2,757	

PHK

Max. Motor Shaft Diameter

Adapter	Shaft	Adapter	Shaft	Adapter	Shaft
MT10	19	MT30	38	MT50	60
MT20	24	MT40	48		

See Page 116 for Options and Part Number Configuration.



"PHK" Series – Right Angle ServoFit® Precision Planetary Gearhead Selection Data



PHK

Part Number	Reducer Ratio i		Input RPM			Backlash arcmins Δφ	Input Inertia J ₁ kgcm ²	Torsional Stiffness per arcmin C ₂ in.lbs. Nm		Output Torque					
			Maximum							Nominal ¹⁾ M _{2N} ≤ 2000 RPM in.lbs. Nm	Acceleration		Peak ²⁾		
	Nom.	Exact	n _{1DBH}	n _{1DBV}	n _{1ZB}	M _{2B}	M _{2PEAK}								
						in.lbs.	Nm	in.lbs.	Nm	in.lbs.	Nm				
PH931_K513 with Motor Mounting Plate															
PH931F0040K513VF0081MT30	32.54	17081/525	1,900	1,800	3,000	4,5	21.39	3,097	350	21,694	2,449	27,640	3,120	50,255	5,673
PH931F0040K513VF0081MT40	32.54	17081/525	1,900	1,800	3,000	4,5	25.39	3,757	424	21,694	2,449	34,015	3,840	57,401	6,480
PH931F0040K513VF0100MT30	40.60	203/5	1,900	1,800	3,000	4,5	17.12	3,517	397	23,215	2,621	34,015	3,840	62,711	7,080
PH931F0040K513VF0100MT40	40.60	203/5	1,900	1,800	3,000	4,5	21.12	4,033	455	23,215	2,621	34,015	3,840	66,435	7,500
PH931F0060K513VF0081MT30	48.80	17081/350	1,900	1,800	3,000	4	20.72	4,937	557	26,574	3,000	39,861	4,500	75,383	8,510
PH931F0060K513VF0081MT40	48.80	17081/350	1,900	1,800	3,000	4	24.72	5,639	637	26,574	3,000	39,861	4,500	79,722	9,000
PH931F0060K513VF0100MT30	60.90	609/10	1,900	1,800	3,000	4	16.69	5,393	609	26,574	3,000	39,861	4,500	79,722	9,000
PH931F0060K513VF0100MT40	60.90	609/10	1,900	1,800	3,000	4	20.69	5,909	667	26,574	3,000	39,861	4,500	79,722	9,000
PH931F0060K513VF0130MT30	76.85	1537/20	2,300	2,200	3,600	4	13.51	5,748	649	26,574	3,000	39,861	4,500	79,722	9,000
PH931F0060K513VF0130MT40	76.85	1537/20	2,300	2,200	3,500	4	17.51	6,105	689	26,574	3,000	39,861	4,500	79,722	9,000
PH931F0060K513VF0160MT20	96.56	26071/270	2,300	2,200	3,600	4	6.60	5,730	647	26,574	3,000	34,539	3,899	54,948	6,203
PH931F0060K513VF0160MT30	96.56	26071/270	2,300	2,200	3,600	4	11.40	5,992	676	26,574	3,000	39,861	4,500	79,722	9,000
PH931F0060K513VF0160MT40	96.56	26071/270	2,300	2,200	3,500	4	15.40	6,232	704	26,574	3,000	39,861	4,500	79,722	9,000
PH931F0060K513VF0195MT20	116.1	27869/240	2,800	2,500	4,000	4	5.34	5,939	670	26,574	3,000	39,861	4,500	66,079	7,460
PH931F0060K513VF0195MT30	116.1	27869/240	2,800	2,500	4,000	4	10.14	6,130	692	26,574	3,000	39,861	4,500	79,722	9,000
PH931F0060K513VF0195MT40	116.1	27869/240	2,800	2,500	3,500	4	14.14	6,302	711	26,574	3,000	39,861	4,500	79,722	9,000
PH931F0060K513VF0240MT20	146.1	11687/80	2,800	2,500	4,000	4	4.17	6,122	691	26,574	3,000	39,861	4,500	79,722	9,000
PH931F0060K513VF0240MT30	146.1	11687/80	2,800	2,500	4,000	4	8.97	6,250	706	26,574	3,000	39,861	4,500	79,722	9,000
PH931F0060K513VF0240MT40	146.1	11687/80	2,800	2,500	3,500	4	12.97	6,362	718	26,574	3,000	39,861	4,500	79,722	9,000
PH931F0060K513VF0320MT20	193.8	62031/320	3,400	3,000	4,500	4	3.14	6,266	707	26,574	3,000	39,861	4,500	79,722	9,000
PH931F0060K513VF0320MT30	193.8	62031/320	3,400	3,000	4,000	4	7.94	6,341	716	26,574	3,000	39,861	4,500	79,722	9,000
PH931F0060K513VF0320MT40	193.8	62031/320	3,000	3,000	3,500	4	11.94	6,406	723	26,574	3,000	39,861	4,500	79,722	9,000
PH931F0060K513VF0390MT20	231.2	8091/35	3,400	3,000	4,500	4	2.67	6,324	714	26,574	3,000	39,861	4,500	79,722	9,000
PH931F0060K513VF0390MT30	231.2	8091/35	3,400	3,000	4,000	4	7.47	6,378	720	26,574	3,000	39,861	4,500	79,722	9,000
PH931F0060K513VF0390MT40	231.2	8091/35	3,000	3,000	3,500	4	11.47	6,424	725	26,574	3,000	39,861	4,500	79,722	9,000
PH931F0060K513VF0480MT20	289.0	8091/28	3,400	3,000	4,500	4	2.21	6,374	720	26,574	3,000	39,861	4,500	79,722	9,000
PH931F0060K513VF0480MT30	289.0	8091/28	3,400	3,000	4,000	4	7.01	6,409	724	26,574	3,000	39,861	4,500	79,722	9,000
PH931F0060K513VF0480MT40	289.0	8091/28	3,000	3,000	3,500	4	11.01	6,439	727	26,574	3,000	39,861	4,500	79,722	9,000
PH931F0060K513VF0650MT20	387.3	25172/65	3,400	3,000	4,500	4	1.82	6,415	724	26,574	3,000	39,861	4,500	79,722	9,000
PH931F0060K513VF0650MT30	387.3	25172/65	3,400	3,000	4,000	4	6.62	6,434	726	26,574	3,000	39,861	4,500	79,722	9,000
PH931F0060K513VF0650MT40	387.3	25172/65	3,000	3,000	3,500	4	10.62	6,451	728	26,574	3,000	39,861	4,500	79,722	9,000
PH931F0060K513VF0780MT20	465.6	26071/56	3,400	3,000	4,500	4	1.65	6,430	726	26,574	3,000	39,861	4,500	77,461	8,745
PH931F0060K513VF0780MT30	465.6	26071/56	3,400	3,000	4,000	4	6.45	6,444	727	26,574	3,000	39,861	4,500	77,461	8,745

¹⁾ Maximum torque for continuous input RPM - horizontal output position.
²⁾ Maximum momentary torque for emergency stops or heavy shock load.
 Admissible stops per life of reducer = 1,000 stops maximum.

Index of Symbols

i	... Exact Ratio = Exact Tooth Count
J ₁	... Reducer Inertia
C ₂	... Torsional Stiffness
n _{1DBH}	... Maximum Continuous Input RPM Horizontal Mounting - EL1, 2, 5, 6
n _{1DBV}	... Maximum Continuous Input RPM Vertical Position - EL3 and EL4
n _{1ZB}	... Maximum Cyclic Input RPM
M _{2N}	... Nominal Torque @ 2000 RPM Input
M _{2B}	... Acceleration Torque Maximum
M _{2PEAK}	... Peak Torque



"PHK" Series – Right Angle ServoFit® Precision Planetary Gearhead Selection Data



Part Number	Reducer Ratio i		Input RPM			Backlash arcmins $\Delta\phi$	Input Inertia J ₁ kgcm ²	Torsional Stiffness per arcmin		Output Torque					
			Maximum					C ₂ in.lbs. Nm	Nominal ¹⁾		Acceleration		Peak ²⁾		
	Nom.	Exact	n _{1DBH}	n _{1DBV}	n _{1ZB}	C ₂ in.lbs. Nm	M _{2N ≤ 2000 RPM}		M _{2B}		M _{2PEAK}				
							Continuous	Cyclic	in.lbs.	Nm	in.lbs.	Nm	in.lbs.	Nm	
PH1031_K613 with Motor Mounting Plate															
PH1031F0060K613VF0081MT30	48.64	255285/5248	1,800	1,700	2,900	4	33.92	7,067	798	37,566	4,241	41,323	4,665	75,133	8,482
PH1031F0060K613VF0081MT40	48.64	255285/5248	1,800	1,700	2,900	4	37.92	8,610	972	42,952	4,849	63,270	7,143	85,815	9,688
PH1031F0060K613VF0081MT50	48.64	255285/5248	1,800	1,700	2,900	4	47.92	9,937	1,122	42,952	4,849	66,435	7,500	132,870	15,000
PH1031F0060K613VF0100MT30	60.32	92659/1536	1,800	1,700	2,900	4	26.22	8,022	906	44,290	5,000	51,247	5,785	93,177	10,519
PH1031F0060K613VF0100MT40	60.32	92659/1536	1,800	1,700	2,900	4	30.22	9,246	1,044	44,290	5,000	66,435	7,500	106,425	12,015
PH1031F0060K613VF0100MT50	60.32	92659/1536	1,800	1,700	2,900	4	40.22	10,197	1,151	44,290	5,000	66,435	7,500	132,870	15,000
PH1031F0060K613VF0125MT30	75.77	9699/128	2,200	2,000	3,200	4	20.48	8,836	998	44,290	5,000	64,373	7,267	117,041	13,213
PH1031F0060K613VF0125MT40	75.77	9699/128	2,200	2,000	3,200	4	24.48	9,735	1,099	44,290	5,000	66,435	7,500	132,870	15,000
PH1031F0060K613VF0125MT50	75.77	9699/128	2,200	2,000	3,000	4	34.48	10,381	1,172	44,290	5,000	66,435	7,500	132,870	15,000
PH1031F0060K613VF0160MT30	95.21	54839/576	2,200	2,000	3,200	4	16.40	9,443	1,066	44,290	5,000	66,435	7,500	132,870	15,000
PH1031F0060K613VF0160MT40	95.21	54839/576	2,200	2,000	3,200	4	20.40	10,073	1,137	44,290	5,000	66,435	7,500	132,870	15,000
PH1031F0060K613VF0160MT50	95.21	54839/576	2,200	2,000	3,000	4	30.40	10,502	1,186	44,290	5,000	66,435	7,500	132,870	15,000
PH1031F0060K613VF0190MT20	114.0	51057/448	2,600	2,300	3,600	4	9.01	9,297	1,050	37,059	4,184	40,765	4,602	64,853	7,321
PH1031F0060K613VF0190MT30	114.0	51057/448	2,600	2,300	3,600	4	13.81	9,795	1,106	44,290	5,000	66,435	7,500	132,870	15,000
PH1031F0060K613VF0190MT40	114.0	51057/448	2,600	2,300	3,500	4	17.81	10,259	1,158	44,290	5,000	66,435	7,500	132,870	15,000
PH1031F0060K613VF0190MT50	114.0	51057/448	2,500	2,300	3,000	4	27.81	10,566	1,193	44,290	5,000	66,435	7,500	132,870	15,000
PH1031F0060K613VF0240MT20	144.0	73749/512	2,600	2,300	3,600	4	6.83	9,782	1,104	44,290	5,000	51,524	5,817	81,969	9,254
PH1031F0060K613VF0240MT30	144.0	73749/512	2,600	2,300	3,600	4	11.63	10,120	1,143	44,290	5,000	66,435	7,500	132,870	15,000
PH1031F0060K613VF0240MT40	144.0	73749/512	2,600	2,300	3,500	4	15.63	10,426	1,177	44,290	5,000	66,435	7,500	132,870	15,000
PH1031F0060K613VF0240MT50	144.0	73749/512	2,500	2,300	3,000	4	25.63	10,622	1,199	44,290	5,000	66,435	7,500	132,870	15,000
PH1031F0060K613VF0320MT20	191.1	391437/2048	3,100	2,800	4,000	4	4.84	10,165	1,148	44,290	5,000	66,435	7,500	108,766	12,279
PH1031F0060K613VF0320MT30	191.1	391437/2048	3,100	2,800	4,000	4	9.64	10,370	1,171	44,290	5,000	66,435	7,500	132,870	15,000
PH1031F0060K613VF0320MT40	191.1	391437/2048	3,000	2,800	3,500	4	13.64	10,549	1,191	44,290	5,000	66,435	7,500	132,870	15,000
PH1031F0060K613VF0320MT50	191.1	391437/2048	2,500	2,500	3,000	4	23.64	10,662	1,204	44,290	5,000	66,435	7,500	132,870	15,000
PH1031F0060K613VF0380MT20	229.9	470859/2048	3,100	2,800	4,000	4	3.88	10,329	1,166	44,290	5,000	66,435	7,500	120,396	13,592
PH1031F0060K613VF0380MT30	229.9	470859/2048	3,100	2,800	4,000	4	8.68	10,474	1,182	44,290	5,000	66,435	7,500	132,870	15,000
PH1031F0060K613VF0380MT40	229.9	470859/2048	3,000	2,800	3,500	4	12.68	10,600	1,197	44,290	5,000	66,435	7,500	132,870	15,000
PH1031F0060K613VF0380MT50	229.9	470859/2048	2,500	2,500	3,000	4	22.68	10,679	1,206	44,290	5,000	66,435	7,500	132,870	15,000
PH1031F0060K613VF0480MT20	286.4	119133/416	3,100	2,800	4,000	4	3.08	10,463	1,181	44,290	5,000	66,435	7,500	127,026	14,340
PH1031F0060K613VF0480MT30	286.4	119133/416	3,100	2,800	4,000	4	7.88	10,559	1,192	44,290	5,000	66,435	7,500	127,026	14,340
PH1031F0060K613VF0480MT40	286.4	119133/416	3,000	2,800	3,500	4	11.88	10,641	1,201	44,290	5,000	66,435	7,500	127,026	14,340
PH1031F0060K613VF0640MT20	382.3	391437/1024	3,100	2,800	4,000	4	2.34	10,573	1,194	44,290	5,000	66,435	7,500	132,870	15,000
PH1031F0060K613VF0640MT30	382.3	391437/1024	3,100	2,800	4,000	4	7.14	10,628	1,200	44,290	5,000	66,435	7,500	132,870	15,000
PH1031F0060K613VF0640MT40	382.3	391437/1024	3,000	2,800	3,500	4	11.14	10,674	1,205	44,290	5,000	66,435	7,500	132,870	15,000
PH1031F0060K613VF0760MT20	456.8	380091/832	3,100	2,800	4,000	4	2.04	10,616	1,198	44,290	5,000	66,435	7,500	132,870	15,000
PH1031F0060K613VF0760MT30	456.8	380091/832	3,100	2,800	4,000	4	6.84	10,654	1,203	44,290	5,000	66,435	7,500	132,870	15,000
PH1031F0060K613VF0760MT40	456.8	380091/832	3,000	2,800	3,500	4	10.84	10,687	1,206	44,290	5,000	66,435	7,500	132,870	15,000

PHK

Max. Motor Shaft Diameter

Adapter	Shaft	Adapter	Shaft	Adapter	Shaft
MT10	19	MT30	38	MT50	60
MT20	24	MT40	48		

See Page 116 for Options and Part Number Configuration.



"PHK" Series – Right Angle ServoFit® Precision Planetary Gearhead Dimensional Data



PHK

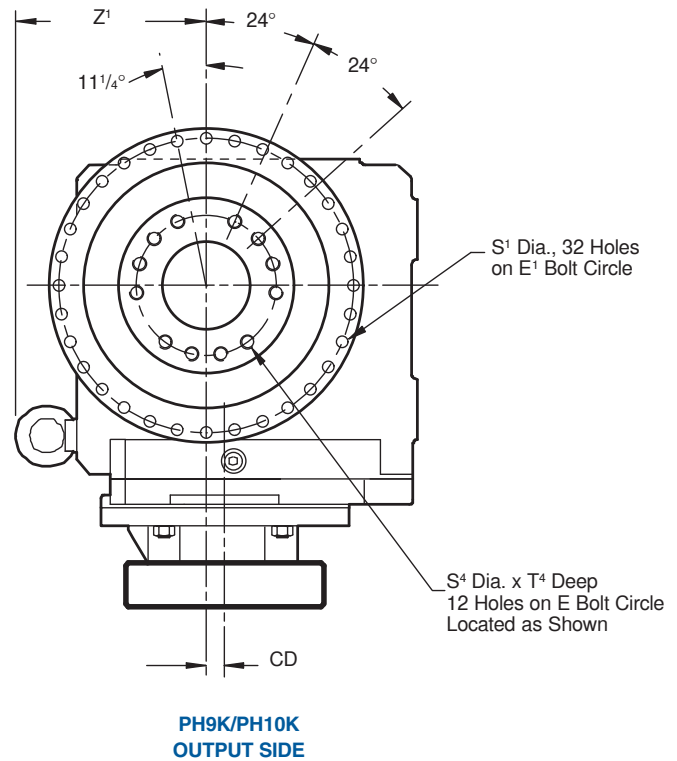
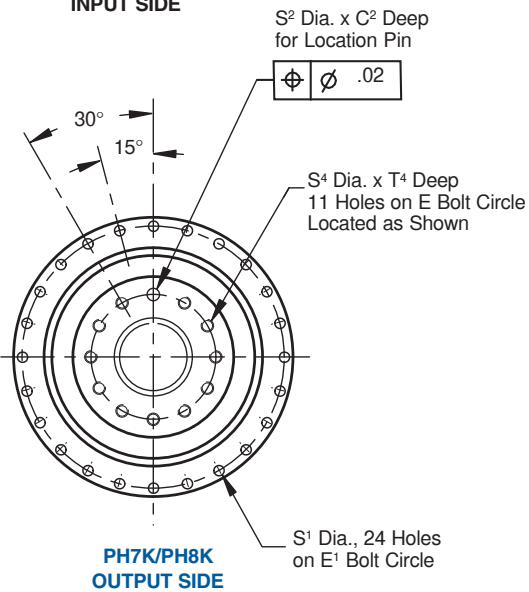
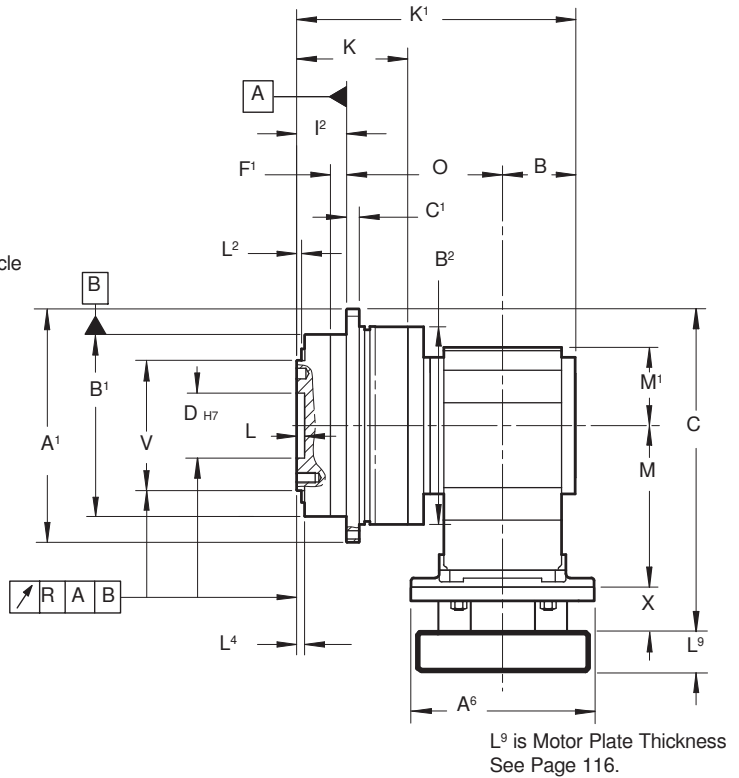
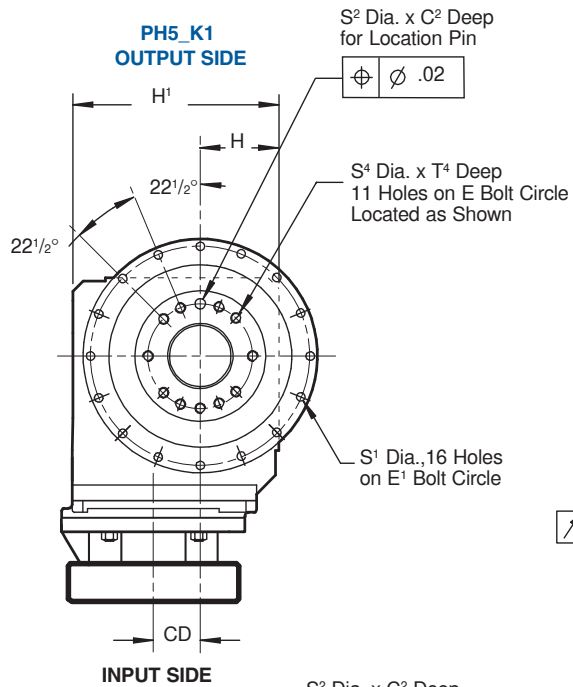

Part No. Example
PH521F0050K102VF0060MT10

Specify: Mounting Position
Side 3 or 4 for PH
Paint, if not *Black*
Motor Information



"PHK" Series – Right Angle ServoFit® Precision Planetary Gearhead Dimensional Data



PHK

Table No. 1 "PHK" Series – Gearhead with Motor Plate – Dimensions (mm/inches)

Unit	A ¹	B	B ¹ h7	B ²	C ¹	C ²	D h7	E	E ¹	F ¹	H	H ¹	I ²	L	L ²	L ⁴	R	S ¹
PH521_K102	145	56	110 +.000/-0.035	120	8	7	40 +.025/-0	63	135	10	60	160	29	6	6	6	.020	5.5
PH721_K102	179	56	140 +.000/-0.040	152	10	7	50 +.025/-0	80	168	12	60	160	38	6	6	6	.025	6.6
PH721_K202	179	70	140 +.000/-0.040	152	10	7	50 +.025/-0	80	168	12	65	190	38	6	6	6	.025	6.6
PH821_K202	247	70	200 +.000/-0.046	212	12	10	80 +.030/-0	125	233	15	65	190	50	8	8	8	.030	9
PH821_K302	247	76	200 +.000/-0.046	212	12	10	80 +.030/-0	125	233	15	75	213	50	8	8	8	.030	9
PH931_K513	300	96	255 +.000/-0.052	255	18	—	90 +.035/-0	140	280	20	160	260	66	12	11	12	.030	13.5
PH1031_K613	330	103.5	285 +.000/-0.052	285	20	—	95 +.035/-0	160	310	20	190	310	75	10	15	15	.040	13.5

Table No. 2 "PHK" Series – Dimensions (mm/inches)

Unit	K	K ¹	M ¹	O	S ² H7	S ⁴	T ⁴	V h7	Z ¹
PH521_K102	70	201	60	116	6 +.012/-0.000	M6	11	80 +.000/-0.030	—
PH721_K102	88	214	60	120	8 +.015/-0.000	M8	14	100 +.000/-0.035	—
PH721_K202	88	242	65	134	8 +.015/-0.000	M8	14	100 +.000/-0.035	—
PH821_K202	126	284.5	65	164.5	10 +.015/-0.000	M10	18	160 +.000/-0.040	—
PH821_K302	126	298	75	172	10 +.015/-0.000	M10	18	160 +.000/-0.040	—
PH931_K513	145	358.5	100	196.5	—	M16	24	180 +.000/-0.040	312
PH1031_K613	126	393.5	120	215	—	M20	30	200 +.000/-0.046	362

Table No. 3 "PHK" Dimensions

Motor Adapter	Motor Shaft D ⁶ Max. ¹⁾	Thickness ²⁾ L ⁹ Min.	A ⁶	X	Wt. lbs.
MT10	19	21	140	40	5
MT20	24	24	160	50	8
MT30	38	25	200	60	12
MT40	48	33	250	50	18
MT50	60	43	300	60	16

¹⁾ If an adapter bushing is required it will be supplied as a component of the motor mounting plate.

²⁾ Motor plate maximum thickness (L⁹) will vary with motor shaft length but will not be less than shown.

Table No. 4 "PHK" Series – ServoFit Precision Planetary Gearhead (mm/inches)

Base Module	MT10			MT20			MT30			MT40			MT50			Wt. lbs.
	CD	C	M	CD	C	M	CD	C	M	CD	C	M	CD	C	M	
PH521_K102	36	236.5	124	36	240.5	128	—	—	—	—	—	—	—	—	—	43
PH721_K102	36	253.5	124	36	263.5	128	—	—	—	—	—	—	—	—	—	53
PH721_K202	46	278.5	143	46	286.5	147	46	296.5	149	—	—	—	—	—	—	69
PH821_K202	46	310.5	143	46	316.5	147	46	330.5	149	—	—	—	—	—	—	116
PH821_K302	52.5	332.5	169	52.5	342.5	169	52.5	352.5	169	—	—	—	—	—	—	134
PH931_K513	—	—	—	—	—	—	15	374	174	15	377	177	—	—	—	213
PH1031_K613	—	—	—	18	401	191	18	403	193	18	406	196	18	420	210	310

See Page 116 for Options and Part Number Configuration.

"PHQ" Series

ServoFit® Precision Planetary Gearhead

Performance Specification Overview



P
H
Q

Size		PHQ722	PHQ723	PHQ822	PHQ823	PHQ932	PHQ933	PHQ1032	PHQ1033	PHQ1132	PHQ1133
Acceleration Torque	in.lbs.	8,408		23,010		53,100		88,500		194,876	
M _{2B} MAX	Nm	950		2,600		6,000		10,000		22,000	
Output Torque Nom. ¹⁾	in.lbs.	5,752		15,045		33,660		57,577		115,154	
M _{2N}	Nm	650		1,700		3,800		6,500		13,000	
Input Speed Max.	Continuous	3,700	4,000	3,300	3,700	2,800	3,300	2,500	2,800	2,300	2,800
n ₁ MAX	Cyclic	6,500	7,000	6,000	6,500	4,500	6,000	4,000	4,500	3,800	4,500
Torsional Backlash Max. ²⁾	Δφ	≤3		≤3		≤3		≤3		≤3	
Torsional Stiffness	in.lbs./arcmin	≤1,840		≤5,840		≤10,885		≤18,320		31,295	
C ₂	Nm/arcmin	≤208		≤660		≤1,230		≤2,068		3,533	
Axial Load Max. ³⁾	lbs.	1,384		2,261		7,425		11,250		13,500	
F _{2AMAX}	N	6,150		10,050		33,000		50,000		60,000	
Tilting Moment Max. ³⁾	in.lbs.	13,275		30,975		66,375		77,880		97,350	
M _{2Kmax}	Nm	1,500		3,500		7,500		8,800		11,000	
Tilting Stiffness	in.lbs./arcmin	4,425		13,718		66,375		84,075		101,775	
C _{2K}	Nm/arcmin	500		1,550		7,500		9,500		11,500	
Weight	pounds	36	38	96	98	189	196	261	293	534	
m	kg	16.3	17.1	43.6	44.3	85.6	88.9	118.2	132.7	242.2	
Noise Level ⁴⁾		≤62		≤63		≤65		≤64		≤66 ≤64	
L _{PA}	dB(A)	≤62		≤63		≤65		≤64		≤66 ≤64	
Efficiency (at Nom. Torque)	h	≥ 90% — 93%									
Degree of Protection		IP65 - FKM Shaft Seals									
Lubrication		Synthetic Oil — Lubricated for Life									
Mounting		See Page 133.									
Ambient Temperature		0° C to +40° C (104° F) [Unit temperature ≤ 90° C Max.]									
Finish		Black (RAL 9005)									
Bearing Lifetime ⁵⁾	hours	L _h > 10,000 hours if M _{2K} /M _{2A} < 1.25 and > 1.00 L _h > 20,000 hours if M _{2K} /M _{2A} > 1.25 and < 1.50 L _h > 30,000 hours if M _{2K} /M _{2A} > 1.5									
Warranty		5 Year Limited (2 Years on normal wear items: bearings, seals, etc.)									

¹⁾ Ratings based on input speed (n₁) of 2000 RPM.

For torque at higher input speeds (M_{2NX}) solve the formula, where n₁ = Actual Input Speed.

$$M_{2NX} = \frac{M_{2N}}{\sqrt[3]{\frac{n_1}{2000}}}$$

²⁾ Tested at 1.5% of nominal torque and recorded on the output side of the gearhead.

³⁾ Rating based on output speed (n₂) of 100 RPM. For values at other speeds see Page 133.

⁴⁾ Measurement at one (1) meter distance with input speed (n₁) of 3000 RPM.

⁵⁾ M_{2A} equals actual tilting moment of the application. See Page 133 for calculation details.

WARNING: In order to insure that the specified torque ratings are attained, it is essential to use a grade 12.9 fastener on all output connections.

Refer to Page 302 for ServoFit Precision Planetary Gearhead Selection Procedure.



"PHQ" Series ServoFit® Precision Planetary Gearhead Features

The "PHQ" Series ServoFit Precision Planetary Gearheads is a four-planet system allowing the torque to be distributed over 4 planets instead of 3, resulting in an increase in output torque of $\geq 35\%$ and an increase in torsional rigidity of $\geq 80\%$.

Some other features are:

- Readily Attaches to Any Servo Motor (IEC, NEMA, or Customized Motor Plates*)
- 5 Year Limited Warranty (2 years on bearings, seals, etc.)
- Low Backlash
- High Input Speeds
- Ratios up to 600:1
- Advanced Gear Technology
- Up to 93% Efficiency
- Quiet Running
- Assembled in the U.S.A.



PHQ

High tensile tempered steel single-piece housing

Ring gear machined integral to the housing — not welded or pressed in — and case-hardened, finish-ground sun and planet gears, provide greater concentricity and eliminates speed fluctuation

The patented TriAdapt® motor coupling is designed to allow thermal expansion of the motor shaft — ensuring long motor life by preventing thrust load on the motor bearings.

The TriAdapt® motor shaft adapter system allows installation of motor in minutes — no special tools required



Lubricated for life with high-quality synthetic oil. Input bearing with shields and high temperature grease provide maintenance free operation.

Motor plate can easily be changed to fit your choice of motors

Motor plate pilot toleranced to fit your motor for precise concentricity

Adapter bushings to fit all motor shafts — no key required

Oversized, single-piece planet carrier, made of high tensile material, enables use of higher load capacity bearings and provides highest torsional stiffness possible.

FKM seals for the smallest possible diameter— reduces friction and heat buildup, increases efficiency, and allows continuous duty without additional cooling.

"PHQ" Series ServoFit® Precision Planetary Gearhead



Part No. Explanation

PHQ 8 2 2 F 0050 MT L

Series Size Generation No. of Gear Stages Housing Ratio Input Input Option

- Series **PHQ** Quattro Power ServoFit Planetary Gearhead
- Size **8** 7, 8, 9, 10, 11
- Generation **2** First generation 1, second generation 2, etc.
- No. of Gear Stages **2** 2, 3 (determined by the ratio)
- Housing Style **F** Output Flange
- Ratio **0050** Approximate: 0050 = 5.00:1 (range of 4:1 up to 600:1)
- Motor Adapter **MT** TriAdapt® Motor Adapter *(Motor information must be specified.)*
ME on PHQ11 ONLY.
- Option **L** Large Input Option



If a "PHQ" gearhead is to be mounted from the "B²" side, SPECIFY WHEN ORDERING. For proper mounting the paint must be eliminated and the tolerance held on that surface. Side "B²" mounting is not possible with the Large Input.

Motor Mounting Specifications

STOBER ServoFit Gearheads will fit the motor of your choice by assembling the correct motor mounting plate between the motor and the gearhead. **When ordering a gearhead, specify the motor manufacturer and part number, provide the motor drawing with dimensions, or specify the motor mounting dimensions.** The motor plate thickness (L⁹) dimension will be determined by the motor shaft length. The minimum motor plate thickness is shown below. For a precise dimension on a specific motor, contact STOBER Technical Support.

The following dimensions are required to provide the correct motor mounting plate:

1. D⁶ Motor Shaft Diameter (If an adapter bushing is required it will be supplied with the motor plate.)
2. D⁷ Pilot Diameter
3. D⁸ Bolt Circle Diameter
4. D⁹ Bolt Diameter
5. L¹¹ Motor Shaft Length
6. L¹² Pilot Length
7. L¹⁴ Square Flange (Optional — Motor plate will typically be made to match.)

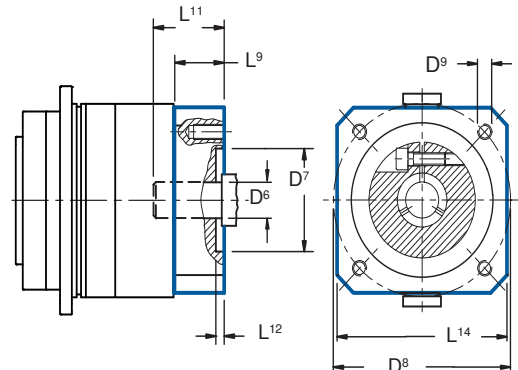

Table No. 1

Motor Plate Dims.	Planetary Size				
	PHQ723	PHQ823 PHQ722	PHQ932 PHQ822	PHQ1033 PHQ932	PHQ1032 PHQ1133
D ⁶ Max.	24	32	38	48	60
L ⁹ Min.	21	24	25	33	43



"PHQ" Series ServoFit® Precision Planetary Gearhead Shaft Loads

Mounting Position

For 3-stage units (ratios $\geq 72:1$), the amount of lubrication depends on the mounting position. **ON THESE UNITS THE MOUNTING POSITION MUST BE SPECIFIED.**

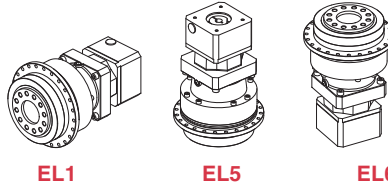

Permissible Shaft Loads

The permissible load and tilting moment values are based on an output speed of 100 RPM. For higher speeds the following applies, where n_2 is the desired speed:

$$F_{2AX} = \frac{F_{2A}}{\sqrt[3]{\frac{n_2}{100}}}$$

$$F_{2RX} = \frac{F_{2R}}{\sqrt[3]{\frac{n_2}{100}}}$$

$$M_{2KX} = \frac{M_{2K}}{\sqrt[3]{\frac{n_2}{100}}}$$

The application input tilting moment should be determined by the following formula:

$$M_{2A} = \frac{F_{2a} \cdot y_2 + F_{2rb} \cdot (X_2 + Z_2)}{1000} \leq M_{2KB}$$

$$M_{2Ka} = \sqrt[3]{\frac{n_{2b1} \cdot t_{b1} \cdot M_{2kb1}^3 + \dots + n_{2bn} \cdot t_{bn} \cdot M_{2kbn}^3}{n_{2b1} \cdot t_{b1} + \dots + n_{2bn} \cdot t_{bn}}} \leq M_{2K}$$

$$F_{2r} = \sqrt[3]{\frac{n_{2b1} \cdot t_{b1} \cdot F_{2rb1}^3 + \dots + n_{2bn} \cdot t_{bn} \cdot F_{2rbn}^3}{n_{2b1} \cdot t_{b1} + \dots + n_{2bn} \cdot t_{bn}}} \leq F_{2RB}$$

- where:
- F_{2a} Axial Load at Output Shaft
 - F_{2A} Permissible Axial Load
 - F_{2r} Radial Load at Output Shaft
 - F_{2R} Permissible Radial Load
 - F_{2RB} Acceleration Permissible Radial Load
 - M_{2K} Rated Tilting Torque
 - M_{2k} Equivalent Tilting Load
 - M_{2KB} Acceleration Tilting Torque
 - Z_2 Distance Factor

The hours of life (L_h) of the unit can be determined by the following formula:

bearing life for duty cycle $\leq 40\%$

- $L_h > 10,000$ hours if $M_{2k}/M_{2A} < 1.25$ and > 1
- $L_h > 20,000$ hours if $M_{2k}/M_{2A} > 1.25$ and > 1.5
- $L_h > 30,000$ hours if $M_{2k}/M_{2A} < 1.5$

bearing life for duty cycle $\geq 40\%$

$$L_{hA} = L_h \left(\frac{40\%}{\text{Duty Cycle}} \right)$$

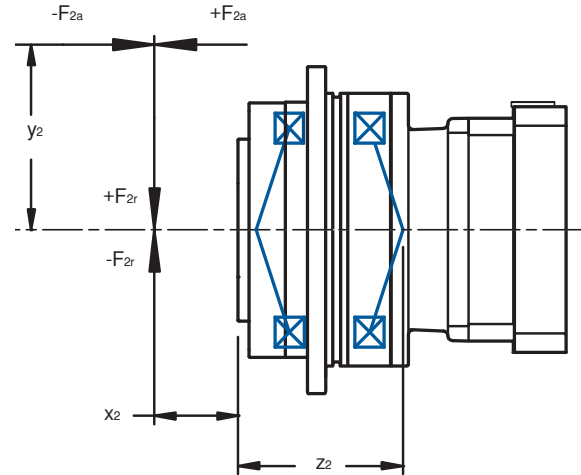

Table No. 2 "PHQ" Series – Permissible Output Load and Tilting Moments

Unit No.	Z_2		F_{2AMAX}		F_{2R}		F_{2RB}		M_{2K}		M_{2KB}		C_{2K}	
	mm	inches	N	lbs.	N	lbs.	N	lbs.	Nm	in.lbs.	Nm	in.lbs.	Nm/arcmin	In.lbs/arcmin
PHQ7	88	3.46	6,150	1,384	17,045	3,835	17,045	3,835	1,500	13,275	1,500	13,275	500	4,425
PHQ8	126	4.96	10,050	2,261	27,778	6,250	27,778	6,250	3,500	30,975	3,500	30,975	1,550	13,718
PHQ9	155	6.10	33,000	7,425	48,387	10,887	70,968	15,938	7,500	66,375	11,000	97,350	7,500	66,375
PHQ10	171	6.73	50,000	11,250	51,462	11,579	73,099	16,447	8,800	77,880	12,500	110,625	9,500	84,075
PHQ11	231	9.09	60,000	13,500	47,619	10,714	60,606	13,636	11,000	97,350	14,000	123,900	9,500	84,075

During EMERGENCY OFF operation (maximum stops per gearhead = 1000) the permissible values in the table for F_{2A} , F_{2R} , and M_{2K} can be multiplied by a factor of 2.

Permissible Motor Tilting Torque

The permissible tilting torque of the motor attached to the gear unit is a result of the static and dynamic load "F" from the motor weight, mass acceleration, and vibration multiplied by the distance from the center of gravity "Is" of the motor.

$$M_{1K} = F \times l_s \leq M_{1K}$$

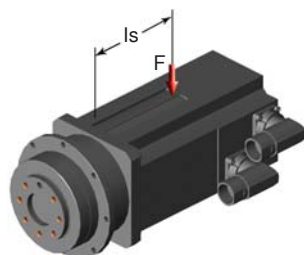

Table No. 3 M_{1K}

Unit Type with MT	Nm	inlbs.
PHQ723	40	354
PHQ722, PHQ823	80	708
PHQ822, PHQ933	200	1,770
PHQ932, PHQ1033, PHQ1133	400	3,540
PHQ1032	800	7,080
PHQ1132	1,000	8,850



"PHQ" Series ServoFit® Precision Planetary Gearhead Selection Data



Part Number (Gearhead + Input)	Exact Ratio i	Maximum Input Speed		Maximum Motor Shaft øD ⁶ mm	Input ¹⁾ Inertia J ₁ kgcm ²	Torsional Stiffness per arcmin C ₂		Output Torque					
		Continuous RPM (n ₁)	Cyclic RPM (n ₁)			in.lbs.	Nm	Nominal ²⁾ M _{2N}		Acceleration M _{2B}		Peak ³⁾ M _{2PEAK}	
								in.lbs.	Nm	in.lbs.	Nm	in.lbs.	Nm

PHQ722 with Motor Mounting Plate

PHQ722F0220 MT	22.00	3,000	5,000	32	4.69	1,837.0	207.4	5,758	650	8,415	950	15,059	1,700
PHQ722F0220 MTL	22.00	3,000	5,000	38	7.72	1,837.0	207.4	5,758	650	8,415	950	15,059	1,700
PHQ722F0280 MT	27.50	3,500	6,000	32	4.22	1,823.1	205.8	5,758	650	8,415	950	15,059	1,700
PHQ722F0280 MTL	27.50	3,500	6,000	38	7.24	1,823.1	205.8	5,758	650	8,415	950	15,059	1,700
PHQ722F0390 MT	38.50	3,700	6,500	32	3.84	1,795.5	202.7	5,758	650	8,415	950	15,059	1,700
PHQ722F0390 MTL	38.50	3,700	6,500	38	6.89	1,795.5	202.7	5,758	650	8,415	950	15,059	1,700
PHQ722F0550 MT	55.00	3,700	6,500	32	3.66	1,731.0	195.4	5,758	650	8,415	950	15,059	1,700
PHQ722F0550 MTL	55.00	3,700	6,500	38	6.71	1,731.0	195.4	5,758	650	8,415	950	15,059	1,700

PHQ723 with Motor Mounting Plate

PHQ723F0880 MT	88.00	3,300	6,000	24	1.63	1,807.6	204.1	5,758	650	8,415	950	15,059	1,700
PHQ723F0880 MTL	88.00	3,300	6,000	32	3.86	1,807.6	204.1	5,758	650	8,415	950	15,059	1,700
PHQ723F1100 MT	110.0	3,300	6,000	24	1.60	1,804.5	203.7	5,758	650	8,415	950	15,059	1,700
PHQ723F1100 MTL	110.0	3,300	6,000	32	3.83	1,804.5	203.7	5,758	650	8,415	950	15,059	1,700
PHQ723F1380 MT	137.5	3,700	6,500	24	1.48	1,803.1	203.6	5,758	650	8,415	950	15,059	1,700
PHQ723F1380 MTL	137.5	3,700	6,500	32	3.70	1,803.1	203.6	5,758	650	8,415	950	15,059	1,700
PHQ723F1540 MT	154.0	4,000	7,000	24	1.35	1,799.8	203.2	5,758	650	8,415	950	15,059	1,700
PHQ723F1540 MTL	154.0	4,000	7,000	32	3.61	1,799.8	203.2	5,758	650	8,415	950	15,059	1,700
PHQ723F1930 MT	192.5	4,000	7,000	24	1.34	1,799.5	203.2	5,758	650	8,415	950	15,059	1,700
PHQ723F1930 MTL	192.5	4,000	7,000	32	3.60	1,799.5	203.2	5,758	650	8,415	950	15,059	1,700
PHQ723F2200 MT	220.0	4,000	7,000	24	1.29	1,787.2	201.8	5,758	650	8,415	950	15,059	1,700
PHQ723F2200 MTL	220.0	4,000	7,000	32	3.55	1,787.2	201.8	5,758	650	8,415	950	15,059	1,700
PHQ723F2750 MT	275.0	4,000	7,000	24	1.28	1,791.4	202.2	5,758	650	8,415	950	15,059	1,700
PHQ723F2750 MTL	275.0	4,000	7,000	32	3.55	1,791.4	202.2	5,758	650	8,415	950	15,059	1,700
PHQ723F3850 MT	385.0	4,000	7,000	24	1.28	1,779.2	200.9	5,758	650	8,415	950	15,059	1,700
PHQ723F3850 MTL	385.0	4,000	7,000	32	3.54	1,779.2	200.9	5,758	650	8,415	950	15,059	1,700
PHQ723F5500 MT	550.0	4,000	7,000	24	1.28	1,723.5	194.6	5,758	650	8,415	950	15,059	1,700
PHQ723F5500 MTL	550.0	4,000	7,000	32	3.54	1,723.5	194.6	5,758	650	8,415	950	15,059	1,700

¹⁾ Inertia based on maximum input. For lower inertia using smaller diameter input, contact STOBER.

²⁾ Based on input speed: n₁ = 2000 RPM. For torque at higher input speeds (M_{2NX}) solve the formula, where n₁ = Actual Input Speed. $M_{2NX} = \frac{M_{2N}}{\sqrt[3]{\frac{n_1}{2000}}}$

³⁾ Maximum momentary torque for emergency stops or heavy shock load. Admissible stops per life of gearhead = 1,000 stops maximum.



"PHQ" Series ServoFit® Precision Planetary Gearhead Selection Data



Part Number (Gearhead + Input)	Exact Ratio i	Maximum Input Speed		Maximum Motor Shaft øD ⁶ mm	Input ¹⁾ Inertia J ₁ kgcm ²	Torsional Stiffness per arcmin C ₂		Output Torque					
		Continuous RPM (n ₁)	Cyclic RPM (n ₁)			in.lbs.	Nm	Nominal ²⁾ M _{2N}		Acceleration M _{2B}		Peak ³⁾ M _{2PEAK}	
								in.lbs.	Nm	in.lbs.	Nm	in.lbs.	Nm

PHQ822 with Motor Mounting Plate

PHQ822F0220 MT	22.00	2,500	4,500	38	11.00	5,855.1	661.0	15,059	1,700	23,031	2,600	35,432	4,000
PHQ822F0220 MTL	22.00	2,500	4,500	48	28.85	5,855.1	661.0	15,059	1,700	23,031	2,600	35,432	4,000
PHQ822F0280 MT	27.50	3,000	5,500	38	9.25	5,810.8	656.0	15,059	1,700	23,031	2,600	35,432	4,000
PHQ822F0280 MTL	27.50	3,000	5,500	48	27.10	5,810.8	656.0	15,059	1,700	23,031	2,600	35,432	4,000
PHQ822F0390 MT	38.50	3,300	6,000	38	7.87	5,695.7	643.0	15,059	1,700	23,031	2,600	35,432	4,000
PHQ822F0390 MTL	38.50	3,300	6,000	48	26.18	5,695.7	643.0	15,059	1,700	23,031	2,600	35,432	4,000
PHQ822F0550 MT	55.00	3,300	6,000	38	7.20	5,447.7	615.0	14,031	1,584	23,031	2,600	35,432	4,000
PHQ822F0550 MTL	55.00	3,300	6,000	48	25.50	5,447.7	615.0	14,031	1,584	23,031	2,600	35,432	4,000

PHQ823 with Motor Mounting Plate

PHQ823F0880 MT	88.00	3,000	5,000	32	4.81	5,731.1	647.0	15,059	1,700	23,031	2,600	35,432	4,000
PHQ823F0880 MTL	88.00	3,000	5,000	38	7.84	5,731.1	647.0	15,059	1,700	23,031	2,600	35,432	4,000
PHQ823F1100 MT	110.0	3,000	5,000	32	4.70	5,731.1	647.0	15,059	1,700	23,031	2,600	35,432	4,000
PHQ823F1100 MTL	110.0	3,000	5,000	38	7.73	5,731.1	647.0	15,059	1,700	23,031	2,600	35,432	4,000
PHQ823F1380 MT	137.5	3,500	6,000	32	4.22	5,722.3	646.0	15,059	1,700	23,031	2,600	35,432	4,000
PHQ823F1380 MTL	137.5	3,500	6,000	38	7.25	5,722.3	646.0	15,059	1,700	23,031	2,600	35,432	4,000
PHQ823F1540 MT	154.0	3,700	6,500	32	3.88	5,713.4	645.0	15,059	1,700	23,031	2,600	35,432	4,000
PHQ823F1540 MTL	154.0	3,700	6,500	38	6.93	5,713.4	645.0	15,059	1,700	23,031	2,600	35,432	4,000
PHQ823F1930 MT	192.5	3,700	6,500	32	3.85	5,713.4	645.0	15,059	1,700	23,031	2,600	35,432	4,000
PHQ823F1930 MTL	192.5	3,700	6,500	38	6.90	5,713.4	645.0	15,059	1,700	23,031	2,600	35,432	4,000
PHQ823F2200 MT	220.0	3,700	6,500	32	3.68	5,678.0	641.0	15,059	1,700	23,031	2,600	35,432	4,000
PHQ823F2200 MTL	220.0	3,700	6,500	38	6.73	5,678.0	641.0	15,059	1,700	23,031	2,600	35,432	4,000
PHQ823F2750 MT	275.0	3,700	6,500	32	3.66	5,695.7	643.0	15,059	1,700	23,031	2,600	35,432	4,000
PHQ823F2750 MTL	275.0	3,700	6,500	38	6.71	5,695.7	643.0	15,059	1,700	23,031	2,600	35,432	4,000
PHQ823F3850 MT	385.0	3,700	6,500	32	3.65	5,624.8	635.0	15,059	1,700	23,031	2,600	35,432	4,000
PHQ823F3850 MTL	385.0	3,700	6,500	38	6.70	5,624.8	635.0	15,059	1,700	23,031	2,600	35,432	4,000
PHQ823F5500 MT	550.0	3,700	6,500	32	3.64	5,412.2	611.0	14,031	1,584	23,031	2,600	35,432	4,000
PHQ823F5500 MTL	550.0	3,700	6,500	38	6.69	5,412.2	611.0	14,031	1,584	23,031	2,600	35,432	4,000

PHQ

Index of Symbols: **MT** — Motor adapter with TriAdapt® coupling; **ME** — Motor adapter with EasyAdapt® coupling; **L** — Large Input; **C** — ServoCool

See Page 132 for Options and Part Number Configuration.



"PHQ" Series ServoFit® Precision Planetary Gearhead Selection Data



Part Number (Gearhead + Input)	Exact Ratio i	Maximum Input Speed		Maximum Motor Shaft øD ⁶ mm	Input ¹⁾ Inertia J ₁ kgcm ²	Torsional Stiffness per arcmin		Output Torque					
		Continuous RPM (n ₁)	Cyclic RPM (n ₂)			C ₂		Nominal ²⁾ M _{2N}		Acceleration M _{2B}		Peak ³⁾ M _{2PEAK}	
						in.lbs.	Nm	in.lbs.	Nm	in.lbs.	Nm	in.lbs.	Nm

PHQ932 with Motor Mounting Plate

PHQ932F0180 MT	18.00	1,800	3,000	48	71.30	10,961.3	1,237.4	33,660	3,800	53,148	6,000	106,296	12,000
PHQ932F0180 MTL	18.00	1,800	3,000	60	94.25	10,808.4	1,220.2	33,660	3,800	53,148	6,000	106,296	12,000
PHQ932F0240 MT	24.00	2,200	3,500	48	42.54	10,851.3	1,225.0	33,660	3,800	53,148	6,000	106,296	12,000
PHQ932F0240 MTL	24.00	2,200	3,500	60	65.49	10,766.5	1,215.5	33,660	3,800	53,148	6,000	106,296	12,000
PHQ932F0300 MT	30.00	2,500	4,000	48	35.62	10,752.9	1,213.9	33,660	3,800	53,148	6,000	106,296	12,000
PHQ932F0300 MTL	30.00	2,500	4,000	60	58.57	10,699.4	1,207.9	33,660	3,800	53,148	6,000	106,296	12,000
PHQ932F0420 MT	42.00	2,800	4,500	48	29.79	10,580.9	1,194.5	33,660	3,800	53,148	6,000	106,296	12,000
PHQ932F0420 MTL	42.00	2,800	4,500	55	57.80	10,554.4	1,191.5	33,660	3,800	53,148	6,000	106,296	12,000
PHQ932F0600 MT	60.00	2,800	4,500	48	27.07	10,180.8	1,149.3	33,660	3,800	53,148	6,000	106,296	12,000
PHQ932F0600 MTL	60.00	2,800	4,500	55	55.09	10,168.8	1,148.0	33,660	3,800	53,148	6,000	106,296	12,000

PHQ933 with Motor Mounting Plate

PHQ933F0720 MT	72.00	2,200	4,500	38	13.04	10,676.6	1,205.3	33,660	3,800	53,148	6,000	106,296	12,000
PHQ933F0720 MTL	72.00	2,200	4,500	48	30.89	10,676.6	1,205.3	33,660	3,800	53,148	6,000	106,296	12,000
PHQ933F0960 MT	96.00	2,500	4,500	38	11.25	10,692.5	1,207.1	33,660	3,800	53,148	6,000	106,296	12,000
PHQ933F0960 MTL	96.00	2,500	4,500	48	29.10	10,692.5	1,207.1	33,660	3,800	53,148	6,000	106,296	12,000
PHQ933F1200 MT	120.0	2,500	4,500	38	10.81	10,652.6	1,202.6	33,660	3,800	53,148	6,000	106,296	12,000
PHQ933F1200 MTL	120.0	2,500	4,500	48	28.66	10,652.6	1,202.6	33,660	3,800	53,148	6,000	106,296	12,000
PHQ933F1500 MT	150.0	3,000	5,500	38	9.13	10,646.5	1,201.9	33,660	3,800	53,148	6,000	106,296	12,000
PHQ933F1500 MTL	150.0	3,000	5,500	48	26.98	10,646.5	1,201.9	33,660	3,800	53,148	6,000	106,296	12,000
PHQ933F1680 MT	168.0	3,300	6,000	38	7.96	10,660.6	1,203.5	33,660	3,800	53,148	6,000	106,296	12,000
PHQ933F1680 MTL	168.0	3,300	6,000	48	26.26	10,660.6	1,203.5	33,660	3,800	53,148	6,000	106,296	12,000
PHQ933F2100 MT	210.0	3,300	6,000	38	7.81	10,632.3	1,200.3	33,660	3,800	53,148	6,000	106,296	12,000
PHQ933F2100 MTL	210.0	3,300	6,000	48	26.12	10,632.3	1,200.3	33,660	3,800	53,148	6,000	106,296	12,000
PHQ933F2400 MT	240.0	3,300	6,000	38	7.24	10,607.8	1,197.5	33,660	3,800	53,148	6,000	106,296	12,000
PHQ933F2400 MTL	240.0	3,300	6,000	48	25.54	10,607.8	1,197.5	33,660	3,800	53,148	6,000	106,296	12,000
PHQ933F3000 MT	300.0	3,300	6,000	38	7.17	10,598.6	1,196.5	33,660	3,800	53,148	6,000	106,296	12,000
PHQ933F3000 MTL	300.0	3,300	6,000	48	25.47	10,598.6	1,196.5	33,660	3,800	53,148	6,000	106,296	12,000
PHQ933F4200 MT	420.0	3,300	6,000	38	7.11	10,488.0	1,184.0	33,660	3,800	53,148	6,000	106,296	12,000
PHQ933F4200 MTL	420.0	3,300	6,000	48	25.42	10,488.0	1,184.0	33,660	3,800	53,148	6,000	106,296	12,000
PHQ933F6000 MT	600.0	3,300	6,000	38	7.09	10,138.5	1,144.6	33,660	3,800	53,148	6,000	106,296	12,000
PHQ933F6000 MTL	600.0	3,300	6,000	48	25.39	10,138.5	1,144.6	33,660	3,800	53,148	6,000	106,296	12,000

PHQ1032 with Motor Mounting Plate

PHQ1032F0240 MT	24.00	2,000	3,000	60	95.79	18,268.8	2,062.4	57,577	6,500	88,580	10,000	177,160	20,000
PHQ1032F0300 MT	30.00	2,200	3,500	60	77.22	18,232.6	2,058.3	57,577	6,500	88,580	10,000	177,160	20,000
PHQ1032F0420 MT	42.00	2,500	4,000	60	62.49	18,070.9	2,040.1	57,577	6,500	88,580	10,000	177,160	20,000
PHQ1032F0600 MT	60.00	2,500	4,000	60	55.17	17,454.3	1,970.5	57,577	6,500	88,580	10,000	177,160	20,000

¹⁾ Inertia based on maximum input. For lower inertia using smaller diameter input, contact STOBER.

²⁾ Based on input speed: n₁ = 2000 RPM. For torque at higher input speeds (M_{2NX}) solve the formula, where n₁ = Actual Input Speed. $M_{2NX} = \frac{M_{2N}}{\sqrt[3]{\frac{n_1}{2000}}}$

³⁾ Maximum momentary torque for emergency stops or heavy shock load. Admissible stops per life of gearhead = 1,000 stops maximum.



"PHQ" Series ServoFit® Precision Planetary Gearhead Selection Data



Part Number (Gearhead + Input)	Exact Ratio i	Maximum Input Speed		Maximum Motor Shaft øD ⁶ mm	Input ¹⁾ Inertia J ₁ kgcm ²	Torsional Stiffness per arcmin C ₂		Output Torque					
		Continuous RPM (n ₁)	Cyclic RPM (n ₂)			in.lbs.	Nm	Nominal ²⁾ M _{2N}		Acceleration M _{2B}		Peak ³⁾ M _{2PEAK}	
								in.lbs.	Nm	in.lbs.	Nm	in.lbs.	Nm

PHQ1033 with Motor Mounting Plate

PHQ1033F0960 MT	96.00	2,200	3,500	48	43.73	18,320.3	2,068.2	57,577	6,500	88,580	10,000	177,160	20,000
PHQ1033F0960 MTL	96.00	2,200	3,500	60	66.68	18,305.1	2,066.5	57,577	6,500	88,580	10,000	177,160	20,000
PHQ1033F1200 MT	120.0	2,200	3,500	48	42.57	18,265.4	2,062.0	57,577	6,500	88,580	10,000	177,160	20,000
PHQ1033F1200 MTL	120.0	2,200	3,500	60	65.52	18,255.7	2,060.9	57,577	6,500	88,580	10,000	177,160	20,000
PHQ1033F1500 MT	150.0	2,500	4,000	48	35.64	18,254.1	2,060.8	57,577	6,500	88,580	10,000	177,160	20,000
PHQ1033F1500 MTL	150.0	2,500	4,000	60	58.59	18,247.9	2,060.1	57,577	6,500	88,580	10,000	177,160	20,000
PHQ1033F1680 MT	168.0	2,800	4,500	48	30.18	18,282.5	2,064.0	57,577	6,500	88,580	10,000	177,160	20,000
PHQ1033F1680 MTL	168.0	2,800	4,500	55	58.19	18,277.6	2,063.4	57,577	6,500	88,580	10,000	177,160	20,000
PHQ1033F2100 MT	210.0	2,800	4,500	48	29.80	18,241.3	2,059.3	57,577	6,500	88,580	10,000	177,160	20,000
PHQ1033F2100 MTL	210.0	2,800	4,500	55	57.81	18,238.2	2,059.0	57,577	6,500	88,580	10,000	177,160	20,000
PHQ1033F2400 MT	240.0	2,800	4,500	48	27.27	18,205.9	2,055.3	57,577	6,500	88,580	10,000	177,160	20,000
PHQ1033F2400 MTL	240.0	2,800	4,500	55	55.28	18,203.5	2,055.0	57,577	6,500	88,580	10,000	177,160	20,000
PHQ1033F3000 MT	300.0	2,800	4,500	48	27.08	18,196.1	2,054.2	57,577	6,500	88,580	10,000	177,160	20,000
PHQ1033F3000 MTL	300.0	2,800	4,500	55	55.09	18,194.5	2,054.0	57,577	6,500	88,580	10,000	177,160	20,000
PHQ1033F4200 MT	420.0	2,800	4,500	48	26.93	18,038.5	2,036.4	57,577	6,500	88,580	10,000	177,160	20,000
PHQ1033F4200 MTL	420.0	2,800	4,500	55	54.95	18,037.7	2,036.3	57,577	6,500	88,580	10,000	177,160	20,000
PHQ1033F6000 MT	600.0	2,800	4,500	48	26.86	17,439.5	1,968.8	57,577	6,500	88,580	10,000	177,160	20,000
PHQ1033F6000 MTL	600.0	2,800	4,500	55	54.87	17,439.2	1,968.7	57,577	6,500	88,580	10,000	177,160	20,000

PHQ1132 with Motor Mounting Plate

PHQ1132F0240 ME	24.00	1,800	3,800	60	175	31,295.3	3,533.0	115,154	13,000	194,876	22,000	296,298	33,480
PHQ1132F0300 ME	30.00	2,000	3,300	60	128	31,311.3	3,538.0	115,154	13,000	194,876	22,000	354,320	40,000
PHQ1132F0420 ME	42.00	2,300	3,800	60	89	31,107.8	3,515.0	115,154	13,000	194,876	22,000	354,320	40,000
PHQ1132F0600 ME	60.00	2,300	2,800	60	71	30,621.0	3,460.0	106,200	12,000	141,600	16,000	283,200	32,000

PHQ1133 with Motor Mounting Plate

PHQ1133F0960 ME	96.00	2,200	3,500	48	48.363	31,295.3	3,533.0	115,154	13,000	194,876	22,000	354,320	40,000
PHQ1133F0960 MEL	96.00	2,200	3,500	60	75.926	31,250.9	3,528.0	115,154	13,000	194,876	22,000	354,320	40,000
PHQ1133F1200 ME	120.0	2,200	3,500	48	45.435	31,127.0	3,514.0	115,154	13,000	194,876	22,000	354,320	40,000
PHQ1133F1200 MEL	120.0	2,200	3,500	60	72.998	31,098.9	3,510.8	115,154	13,000	194,876	22,000	354,320	40,000
PHQ1133F1500 ME	150.0	2,500	4,000	48	39.165	31,091.6	3,510.0	115,154	13,000	194,876	22,000	354,320	40,000
PHQ1133F1500 MEL	150.0	2,500	4,000	60	66.728	31,073.6	3,508.0	115,154	13,000	194,876	22,000	354,320	40,000
PHQ1133F1680 ME	168.0	2,800	4,500	48	36.832	31,180.2	3,520.0	115,154	13,000	194,876	22,000	354,320	40,000
PHQ1133F1680 MEL	168.0	2,800	4,500	55	60.232	31,165.8	3,518.4	115,154	13,000	194,876	22,000	354,320	40,000
PHQ1133F2100 ME	210.0	2,800	4,500	48	33.904	31,056.1	3,506.0	115,154	13,000	194,876	22,000	354,320	40,000
PHQ1133F2100 MEL	210.0	2,800	4,500	55	57.304	31,047.0	3,505.0	115,154	13,000	194,876	22,000	354,320	40,000
PHQ1133F2400 ME	240.0	2,800	4,500	48	34.419	30,976.4	3,497.0	115,154	13,000	194,876	22,000	354,320	40,000
PHQ1133F2400 MEL	240.0	2,800	4,500	55	57.819	30,969.5	3,496.2	115,154	13,000	194,876	22,000	354,320	40,000
PHQ1133F3000 ME	300.0	2,800	4,500	48	31.492	30,923.3	3,491.0	115,154	13,000	194,876	22,000	354,320	40,000
PHQ1133F3000 MEL	300.0	2,800	4,500	55	54.892	30,918.8	3,490.5	115,154	13,000	194,876	22,000	354,320	40,000

Index of Symbols: **MT** — Motor adapter with TriAdapt® coupling; **ME** — Motor adapter with EasyAdapt® coupling; **L** — Large Input; **C** — ServoCool

See Page 132 for Options and Part Number Configuration.



"PHQ" Series ServoFit® Precision Planetary Gearhead Dimensional Data



P
H
Q

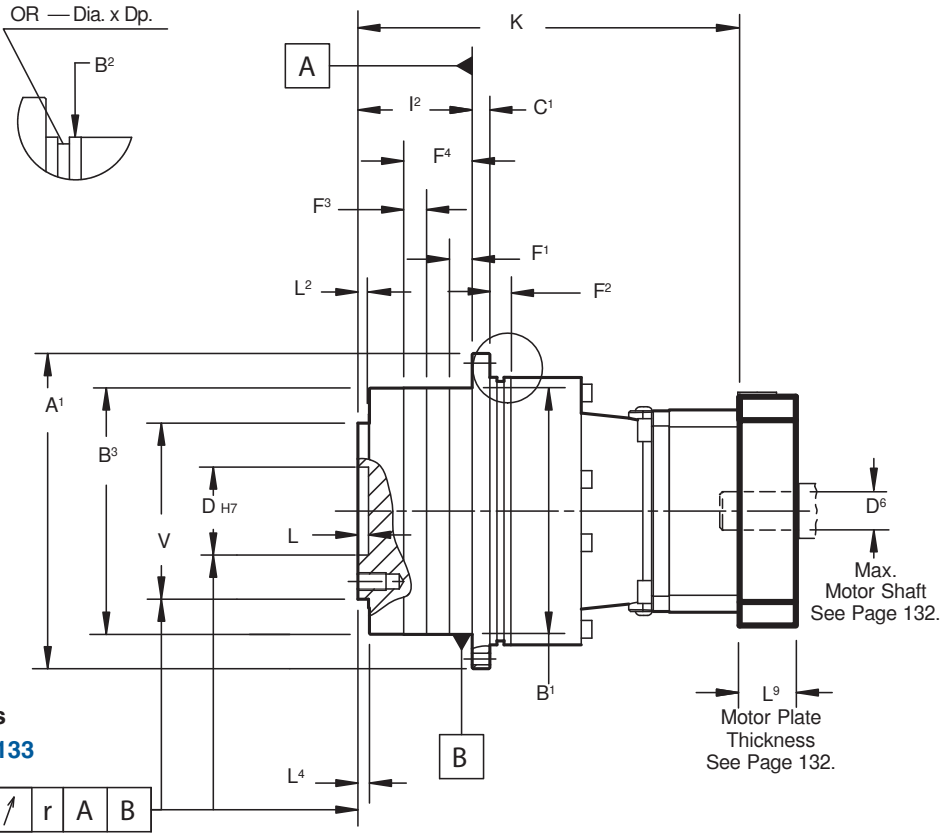

Drawing for Units
PHQ722 thru PHQ1133

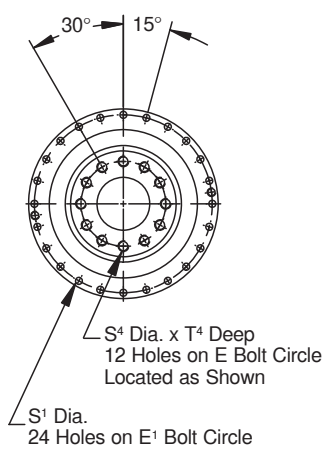

PHQ7/PHQ8
OUTPUT SIDE

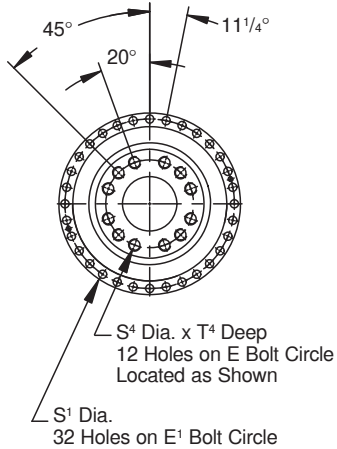

PHQ9
OUTPUT SIDE

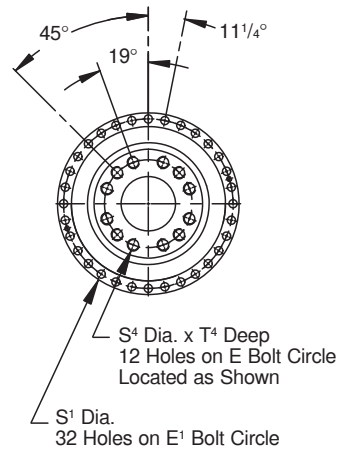

PHQ10
OUTPUT SIDE

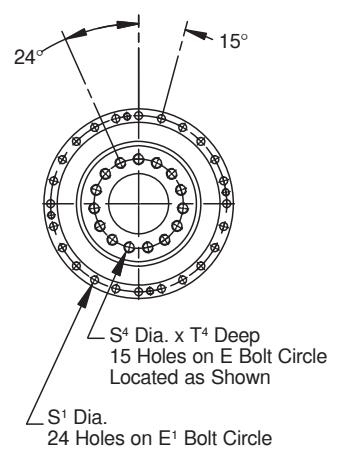

PHQ11
OUTPUT SIDE

Part No. Example
PHQ822F0050MTL
Specify: Mounting Position (if third stage)
B² Side Mounting, if required
Paint, if not *Black*
Motor Information

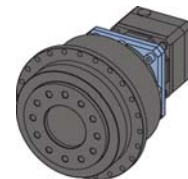

Typical 3 Stage Configuration



"PHQ" Series ServoFit® Precision Planetary Gearhead Dimensional Data



Table No. 1

"PHQ" Series – Gearhead with Motor Plate – Dimensions (mm)

Unit	A ¹	B ¹	B ²	B ³	C ¹	D _{H6}	E	E ¹	F ¹	F ²	F ¹	F ²	I ²	L	L ²	L ⁴	OR
PHQ722/PHQ723	179 _{h7}	140 _{h7}	152 _{h7}	—	10	50	80	168	12	12	—	—	38	6	6	6	145x3
PHQ822/PHQ823	247 _{h7}	200 _{h7}	212 _{h7}	—	12	80	125	233	15	15	—	—	50	8	8	8.5	200x5
PHQ932/PHQ933	300 _{h7}	255 _{h7}	255 _{h7}	—	18	90	145	280	20	33	—	—	66	12	11	12	238x5
PHQ1032/PHQ1033	330 _{h7}	285 _{h7}	285 _{h7}	—	20	95	166	310	20	20	—	—	75	10	15	15	270x6
PHQ1132/PHQ1133	425	365 _{h6}	—	365 _{h6}	32	120	200	395	30	30	30	120	190	10	10	10	—

Table No. 2 "PHQ" Dimensions (mm)

Unit	R	S ¹	S ⁴	T ⁴	V _{h7}
PHQ722/PHQ723	.025	6.6	M10	16	100
PHQ822/PHQ823	.030	9	M12	17	160
PHQ932/PHQ933	.030	13.5	M20	28	180
PHQ1032/PHQ1033	.040	13.5	M24	35	200
PHQ1132/PHQ1133	.040	17.5	M24	36	260

Table No. 3 Dimensions (mm)

Standard			Large Input		
Unit	A ⁵	K	Unit	A ⁵	K
PHQ722	115	190	PHQ722_L	145	204
PHQ723	100	239.5	PHQ723_L	115	248
PHQ822	145	251	PHQ822_L	190	268
PHQ823	115	303	PHQ823_L	145	204
PHQ932	190	316	PHQ932_L	225	357.5
PHQ933	145	383.5	PHQ933_L	190	434
PHQ1032	225	370	—	—	—
PHQ1033	190	458	PHQ1033_L	225	511
PHQ1132	310	473	—	—	—
PHQ1133	190	553.5	PHQ1133_L	225	561.5

If a planetary gearhead is to be mounted from "B²" side, specify when ordering. For proper mounting the paint must be eliminated and the tolerance held on that surface.



Side "B²" mounting is not possible with the Large Input.

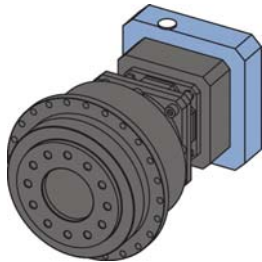

Typical Large Input Configuration

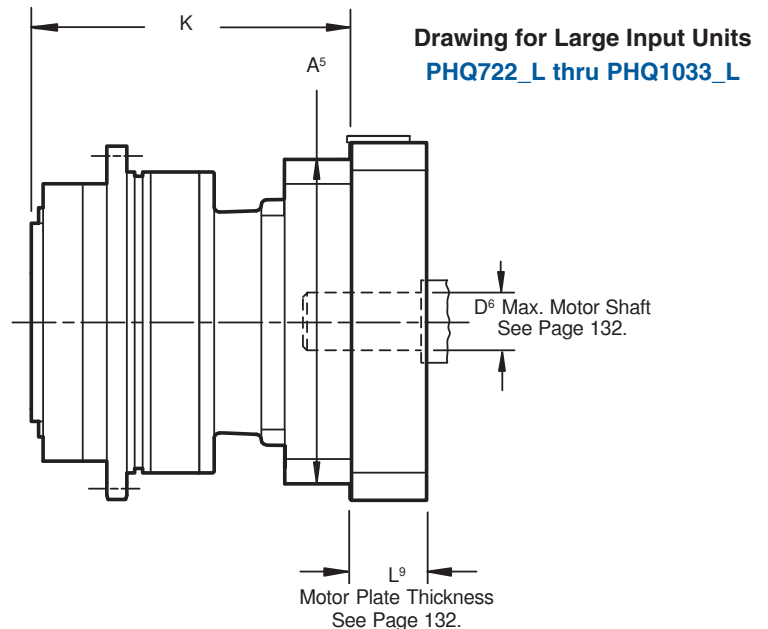

PHQ

See Page 132 for Options and Part Number Configuration.

"PHQA" Series ServoFit® Precision Planetary Gearhead Performance Specifications



P
H
Q
A

Size		PHQA722	PHQA723	PHQA822	PHQA823	PHQA932	PHQA933	PHQA1032	PHQA1033
Acceleration Torque M _{2B} MAX	in.lbs. Nm	8,408 950		23,010 2,600		53,100 6,000		88,500 10,000	
Output Torque Nom. ¹⁾ M _{2N}	in.lbs. Nm	5,752 650		15,045 1,700		33,660 3,800		57,577 6,500	
Input Speed Max. n ₁ MAX	Continuous Cyclic	3,700 6,500	4,000 7,000	3,300 6,000	3,700 6,500	2,800 4,500	3,300 6,000	2,500 4,000	2,800 4,500
Torsional Backlash Max. ²⁾ Δφ	arcmin	≤1		≤1		≤1		≤1.5	
Torsional Stiffness C ₂	in.lbs./arcmin Nm/arcmin	≤1,840 ≤208		≤5,840 ≤660		≤10,885 ≤1,230		≤18,320 ≤2,068	
Axial Load Max. ³⁾ F ₂ MAX	lbs. N	1,384 6,150		2,261 10,050		7,425 33,000		11,250 50,000	
Tilting Moment Max. ³⁾ M _{2K} max	in.lbs. Nm	13,275 1,500		30,975 3,500		66,375 7,500		77,880 8,800	
Tilting Stiffness C _{2K}	in.lbs./arcmin Nm/arcmin	4,425 500		13,718 1,550		66,375 7,500		84,075 9,500	
Weight m	pounds kg	36 16.3	38 17.1	96 43.6	98 44.3	189 85.6	196 88.9	261 118.2	293 132.7
Noise Level ⁴⁾ L _{PA}	dB(A)	≤62		≤63		≤65		≤64	
Efficiency (at Nom. Torque) h	%	≥ 90% — 93%							
Degree of Protection		IP65 - FKM Shaft Seals							
Mounting Position		Must be Specified on 3 Stage Units. See Page 143.							
Lubrication		Synthetic Oil — Lubricated for Life							
Ambient Temperature		0° C to +40° C (104° F) [Unit temperature ≤ 90° C Max.]							
Finish		Black (RAL 9005)							
Bearing Lifetime ⁵⁾ L _h	hours	L _h > 10,000 hours if M _{2K} /M _{2A} < 1.25 and > 1.00 L _h > 20,000 hours if M _{2K} /M _{2A} > 1.25 and < 1.50 L _h > 30,000 hours if M _{2K} /M _{2A} > 1.5							
Warranty		5 Year Limited (2 Years on normal wear items: bearings, seals, etc.)							

¹⁾ Ratings based on input speed (n₁) of 2000 RPM.

For torque at higher input speeds (M_{2NX}) solve the formula, where n₁ = Actual Input Speed.

$$M_{2NX} = \frac{M_{2N}}{\sqrt[3]{\frac{n_1}{2000}}}$$

²⁾ Tested at 1.5% of nominal torque and recorded on the output side of the gearhead.

³⁾ Rating based on output speed (n₂) of 100 RPM. For values at other speeds, see Page 143.

⁴⁾ Measurement at one (1) meter distance with input speed (n₁) of 3000 RPM.

⁵⁾ M_{2A} equals actual tilting moment of the application. See Page 143 for calculation details.

WARNING: In order to insure that the specified torque ratings are attained, it is essential to use a grade 12.9 fastener on all output connections.

Refer to Page 302 for ServoFit Precision Planetary Gearhead Selection Procedure.



"PHQA" Series ServoFit® Precision Planetary Gearhead Features

The "PHQA" Series ServoFit Precision Planetary Gearheads is a four-planet system allowing the torque to be distributed over 4 planets instead of 3, resulting in a $\geq 35\%$ increase in output torque and a $\geq 80\%$ increase in torsional rigidity. Precision selection of the gears ensures the lowest backlash possible of ≤ 1 arcminute.

Some other features are:

- Readily Attaches to Any Servo Motor (IEC, NEMA, or Customized Motor Plates*)
- 5 Year Limited Warranty (2 years on bearings, seals, etc.)
- Low Backlash
- High Input Speeds
- Ratios up to 600:1
- Advanced Gear Technology
- Up to 93% Efficiency
- Quiet Running
- Assembled in the U.S.A.



Lubricated for life with high-quality synthetic oil. Input bearing with shields and high temperature grease provide maintenance free operation.

Ring gear machined integral to the housing — not welded or pressed in — and case-hardened, finish-ground sun and planet gears, provide greater concentricity and eliminates speed fluctuation

Motor plate pilot toleranced to fit your motor for precise concentricity

Motor plate can easily be changed to fit your choice of motors

High tensile tempered steel single-piece housing

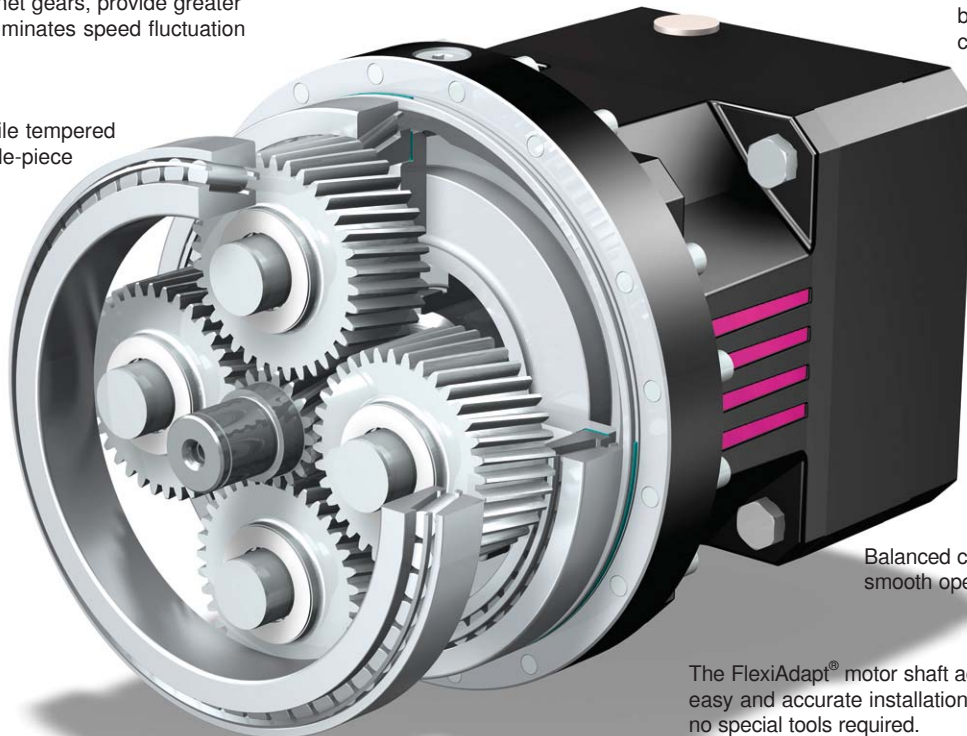

Adapter bushings to fit all motor shafts — no key required

Balanced clamp coupling for smooth operation at high speeds.

The FlexiAdapt® motor shaft adapter system allows easy and accurate installation of motor in minutes — no special tools required.

Oversized, single-piece planet carrier, made of high tensile material, enables use of higher load capacity bearings and provides highest torsional stiffness possible.

FKM seals for the smallest possible diameter—reduces friction and heat buildup, increases efficiency, and allows continuous duty without additional cooling.



Also available as a right angle drive. Contact STOBER Drives.

The FlexiAdapt® motor coupling is designed for large motor shaft diameters and features a bellows coupling to compensate for thermal expansion of the motor shaft—ensuring long motor life by preventing thrust load on the motor bearings.

PHQA

Part No. Configurator

“PHQA” Series – ServoFit Planetary Gearhead



Part No. Explanation

PHQA 8 2 2 F 0050 MF L

Series Size Generation No. of Gear Stages Housing Ratio Input Input Option

Series **PHQA** Advanced Quattro Power ServoFit Planetary Gearhead

Size **8** 7, 8, 9, 10

Generation **2** First generation 1, second generation 2, etc.

No. of Gear Stages **2** 2, 3 (determined by the ratio)

Housing Style **F** Output Flange

Ratio **0050** Approximate: 0050 = 5.00:1 (range of 4:1 up to 600:1)

Motor Adapter **MF** FlexiAdapt® Motor Adapter (**Motor information must be specified.**)

Option **L** Large Input Option



PHQA



If a “PHQA” gearhead is to be mounted from the “B²” side, **SPECIFY WHEN ORDERING**. For proper mounting the paint must be eliminated and the tolerance held on that surface. Side “B²” mounting is not possible with the Large Input.

Motor Mounting Specifications

STOBER ServoFit Gearheads will fit the motor of your choice by assembling the correct motor mounting plate between the motor and the gearhead. **When ordering a gearhead, specify the motor manufacturer and part number, provide the motor drawing with dimensions, or specify the motor mounting dimensions.** The motor plate thickness (L⁹) dimension will be determined by the motor shaft length. The minimum motor plate thickness is shown below. For a precise dimension on a specific motor, contact STOBER Technical Support.

The following dimensions are required to provide the correct motor mounting plate:

1. D⁶ Motor Shaft Diameter (If an adapter bushing is required it will be supplied with the motor plate.)
2. D⁷ Pilot Diameter
3. D⁸ Bolt Circle Diameter
4. D⁹ Bolt Diameter
5. L¹¹ Motor Shaft Length
6. L¹² Pilot Length
7. L¹⁴ Square Flange (Optional — Motor plate will typically be made to match.)

Table No. 1

Motor Plate Dims.	Planetary Size				
	PHQ723	PHQ823 PHQ722	PHQ932 PHQ822	PHQ1033 PHQ932	PHQ1032
D ⁶ Max.	24	32	38	48	60
L ⁹ Min.	21	24	25	33	43

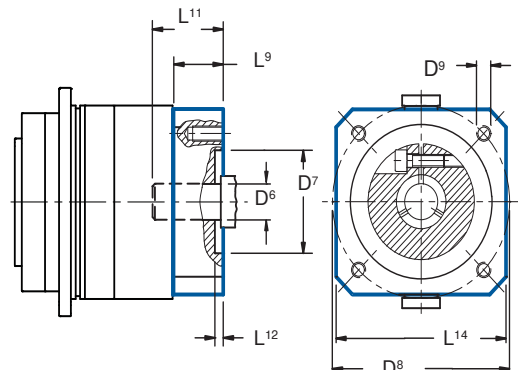



"PHQA" Series ServoFit® Precision Planetary Gearhead Performance Specification Overview

All formulas shown are based on METRIC values.

Upper case letters are permissible values. Lower case letters are for existing values.

Mounting Position

For 3-stage units (ratios $\geq 72:1$), the amount of lubrication depends on the mounting position. **ON THESE UNITS THE MOUNTING POSITION MUST BE SPECIFIED.**

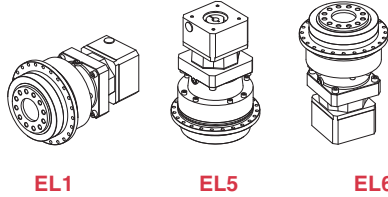

Permissible Shaft Load and Tilting Moment

The permissible load and tilting moment values are based on an output speed of 100 RPM. For higher speeds the following applies, where n_2 is the desired speed:

$$F_{2AX} = \frac{F_{2A}}{\sqrt[3]{\frac{n_2}{100}}} \quad F_{2RX} = \frac{F_{2R}}{\sqrt[3]{\frac{n_2}{100}}} \quad M_{2KX} = \frac{M_{2K}}{\sqrt[3]{\frac{n_2}{100}}}$$

The application input tilting moment should be determined by the following formula:

$$M_{2A} = \frac{F_{2a} \cdot y_2 + F_{2rb} \cdot (X_2 + Z_2)}{1000} \leq M_{2KB}$$

$$M_{2KA} = \sqrt[3]{\frac{n_{2b1} \cdot t_{b1} \cdot M_{2kb1}^3 + \dots + n_{2bn} \cdot t_{bn} \cdot M_{2kbn}^3}{n_{2b1} \cdot t_{b1} + \dots + n_{2bn} \cdot t_{bn}}} \leq M_{2K}$$

$$F_{2r} = \sqrt[3]{\frac{n_{2b1} \cdot t_{b1} \cdot F_{2rb1}^3 + \dots + n_{2bn} \cdot t_{bn} \cdot F_{2rbn}^3}{n_{2b1} \cdot t_{b1} + \dots + n_{2bn} \cdot t_{bn}}} \leq F_{2R}$$

- where:
- F_{2a} Axial Load at Output Shaft
 - F_{2A} Permissible Axial Load
 - F_{2r} Radial Load at Output Shaft
 - F_{2R} Permissible Radial Load
 - F_{2RB} Acceleration Permissible Radial Load
 - M_{2K} Rated Tilting Torque
 - M_{2k} Equivalent Tilting Load
 - M_{2KB} Acceleration Tilting Torque
 - Z_2 Distance Factor

The hours of life (L_h) of the unit can be determined by the following formula:

bearing life for duty cycle $\leq 40\%$

- $L_h > 10,000$ hours if $M_{2k}/M_{2A} < 1.25$ and > 1
- $L_h > 20,000$ hours if $M_{2k}/M_{2A} > 1.25$ and > 1.5
- $L_h > 30,000$ hours if $M_{2k}/M_{2A} < 1.5$

bearing life for duty cycle $\geq 40\%$ $L_{hA} = L_h \left(\frac{40}{\text{Duty Cycle}} \right)$

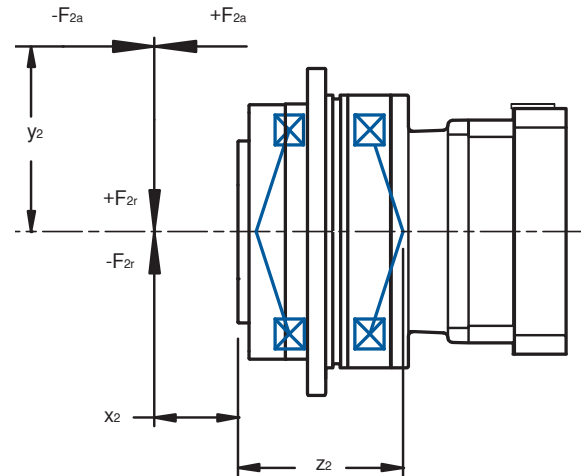

Table No. 2 "PHQ" Series – Permissible Output Load and Tilting Moments

Unit No.	Z_2		F_{2AMAX}		F_{2R}		F_{2RB}		M_{2K}		M_{2KB}		C_{2K}	
	mm	inches	N	lbs.	N	lbs.	N	lbs.	Nm	in.lbs.	Nm	in.lbs.	Nm/arcmin	In.lbs/arcmin
PHQA7	88	3.46	6,150	1,384	17,045	3,835	17,045	3,835	1,500	13,275	1,500	13,275	500	4,425
PHQA8	126	4.96	10,050	2,261	27,778	6,250	27,778	6,250	3,500	30,975	3,500	30,975	1,550	13,718
PHQA9	155	6.10	33,000	7,425	48,387	10,887	70,968	15,938	7,500	66,375	11,000	97,350	7,500	66,375
PHQA10	171	6.73	50,000	11,250	51,462	11,579	73,099	16,447	8,800	77,880	12,500	110,625	9,500	84,075

During EMERGENCY OFF operation (maximum stops per gearhead = 1000) the permissible values in the table for F_{2A} , F_{2R} , and M_{2K} can be multiplied by a factor of 2.

Permissible Motor Tilting Torque

The permissible tilting torque of the motor attached to the gear unit is a result of the static and dynamic load "F" from the motor weight, mass acceleration, and vibration multiplied by the distance from the center of gravity "Is" of the motor.

$$M_{1K} = F \times I_s \leq M_{1K}$$

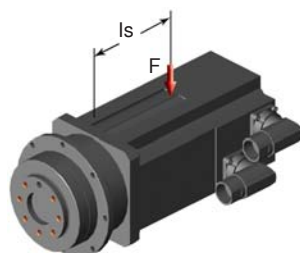

Table No. 3 M1K

Unit Type with MT	Nm	in.lbs.
PHQA723	40	354
PHQA722, PHQA823	80	708
PHQA822, PHQA933	200	1,770
PHQA932, PHQA1033	400	3,540
PHQA1032	800	7,080



"PHQA" Series ServoFit® Precision Planetary Gearhead Selection Data



Part Number (Gearhead + Input)	Exact Ratio i	Maximum Input Speed		Maximum Motor Shaft ØD ⁶ mm	Input ¹⁾ Inertia J ₁ kgcm ²	Torsional Stiffness per arcmin		Output Torque					
		Continuous RPM (n ₁)	Cyclic RPM (n ₁)			C ₂	Nominal ²⁾		Acceleration		Peak ³⁾		
							M _{2N}	M _{2B}	M _{2N}	M _{2PEAK}			
Gearhead						in.lbs.	Nm	in.lbs.	Nm	in.lbs.	Nm	in.lbs.	Nm

PHQA722 with Motor Mounting Plate

PHQA722F0220 MF	22.00	3,000	5,000	≤19	6.00	1,794.3	202.6	5,758	650	8,415	950	16,830	1,900
PHQA722F0220 MF	22.00	3,000	5,000	>19≤24	6.07	1,801.9	203.4	5,758	650	8,415	950	16,830	1,900
PHQA722F0220 MF	22.00	3,000	5,000	>24≤32	5.97	1,801.9	203.4	5,758	650	8,415	950	16,830	1,900
PHQA722F0220 MF	22.00	3,000	5,000	>32≤35	5.97	1,801.9	203.4	5,758	650	8,415	950	16,830	1,900
PHQA722F0220 MFL	22.00	3,000	5,000	>32≤38	13.16	1,817.5	205.2	5,758	650	8,415	950	16,830	1,900
PHQA722F0280 MF	27.50	3,500	6,000	≤19	5.52	1,796.0	202.8	5,758	650	8,415	950	16,830	1,900
PHQA722F0280 MF	27.50	3,500	6,000	>19≤24	5.60	1,800.8	203.3	5,758	650	8,415	950	16,830	1,900
PHQA722F0280 MF	27.50	3,500	6,000	>24≤32	5.50	1,800.8	203.3	5,758	650	8,415	950	16,830	1,900
PHQA722F0280 MF	27.50	3,500	6,000	>32≤35	5.50	1,800.8	203.3	5,758	650	8,415	950	16,830	1,900
PHQA722F0280 MFL	27.50	3,500	6,000	>32≤38	12.69	1,810.8	204.4	5,758	650	8,415	950	16,830	1,900
PHQA722F0390 MF	38.50	3,700	6,500	≤19	5.17	1,781.9	201.2	5,758	650	8,415	950	16,830	1,900
PHQA722F0390 MF	38.50	3,700	6,500	>19≤24	5.17	1,781.9	201.2	5,758	650	8,415	950	16,830	1,900
PHQA722F0390 MF	38.50	3,700	6,500	>24≤32	5.07	1,781.9	201.2	5,758	650	8,415	950	16,830	1,900
PHQA722F0390 MF	38.50	3,700	6,500	>32≤35	5.07	1,781.9	201.2	5,758	650	8,415	950	16,830	1,900
PHQA722F0390 MFL	38.50	3,700	6,500	>32≤38	12.00	1,787.8	201.8	5,758	650	8,415	950	16,830	1,900
PHQA722F0550 MF	55.00	3,700	6,500	≤19	4.99	1,724.8	194.7	5,758	650	8,415	950	16,830	1,900
PHQA722F0550 MF	55.00	3,700	6,500	>19≤24	4.99	1,724.8	194.7	5,758	650	8,415	950	16,830	1,900
PHQA722F0550 MF	55.00	3,700	6,500	>24≤32	4.89	1,724.8	194.7	5,758	650	8,415	950	16,830	1,900
PHQA722F0550 MF	55.00	3,700	6,500	>32≤35	4.89	1,724.8	194.7	5,758	650	8,415	950	16,830	1,900
PHQA722F0550 MFL	55.00	3,700	6,500	>32≤38	11.82	1,727.5	195.0	5,758	650	8,415	950	16,830	1,900

PHQA723 with Motor Mounting Plate *Continued Next Page*

PHQA723F0880 MF	88.00	3,300	6,000	≤14	2.02	1,803.3	203.6	5,758	650	8,415	950	16,830	1,900
PHQA723F0880 MF	88.00	3,300	6,000	>14≤19	2.05	1,804.2	203.7	5,758	650	8,415	950	16,830	1,900
PHQA723F0880 MF	88.00	3,300	6,000	>19≤24	1.95	1,804.2	203.7	5,758	650	8,415	950	16,830	1,900
PHQA723F0880 MFL	88.00	3,300	6,000	>24≤32	5.16	1,805.4	203.8	5,758	650	8,415	950	16,830	1,900
PHQA723F1100 MF	110.0	3,300	6,000	≤14	1.99	1,801.8	203.4	5,758	650	8,415	950	16,830	1,900
PHQA723F1100 MF	110.0	3,300	6,000	>14≤19	2.02	1,802.3	203.5	5,758	650	8,415	950	16,830	1,900
PHQA723F1100 MF	110.0	3,300	6,000	>19≤24	1.92	1,802.3	203.5	5,758	650	8,415	950	16,830	1,900
PHQA723F1100 MFL	110.0	3,300	6,000	>24≤32	5.13	1,803.1	203.6	5,758	650	8,415	950	16,830	1,900
PHQA723F1380 MF	137.5	3,700	6,500	≤14	1.87	1,801.3	203.4	5,758	650	8,415	950	16,830	1,900
PHQA723F1380 MF	137.5	3,700	6,500	>14≤19	1.89	1,801.7	203.4	5,758	650	8,415	950	16,830	1,900
PHQA723F1380 MF	137.5	3,700	6,500	>19≤24	1.79	1,801.7	203.4	5,758	650	8,415	950	16,830	1,900
PHQA723F1380 MFL	137.5	3,700	6,500	>24≤32	5.00	1,802.2	203.5	5,758	650	8,415	950	16,830	1,900
PHQA723F1540 MF	154.0	4,000	7,000	≤14	1.76	1,798.4	203.0	5,758	650	8,415	950	16,830	1,900
PHQA723F1540 MF	154.0	4,000	7,000	>14≤19	1.76	1,798.4	203.0	5,758	650	8,415	950	16,830	1,900
PHQA723F1540 MF	154.0	4,000	7,000	>19≤24	1.66	1,798.4	203.0	5,758	650	8,415	950	16,830	1,900
PHQA723F1540 MFL	154.0	4,000	7,000	>24≤32	4.82	1,798.9	203.1	5,758	650	8,415	950	16,830	1,900
PHQA723F1930 MF	192.5	4,000	7,000	≤14	1.75	1,798.6	203.0	5,758	650	8,415	950	16,830	1,900
PHQA723F1930 MF	192.5	4,000	7,000	>14≤19	1.75	1,798.6	203.0	5,758	650	8,415	950	16,830	1,900
PHQA723F1930 MF	192.5	4,000	7,000	>19≤24	1.65	1,798.6	203.0	5,758	650	8,415	950	16,830	1,900
PHQA723F1930 MFL	192.5	4,000	7,000	>24≤32	4.81	1,799.0	203.1	5,758	650	8,415	950	16,830	1,900

¹⁾ Inertia based on maximum input. For lower inertia using smaller diameter input, contact STOBER.

²⁾ Based on input speed: n₁ = 2000 RPM. For torque at higher input speeds (M_{2NX}) solve the formula, where n₁ = Actual Input Speed. $M_{2NX} = \frac{M_{2N}}{\sqrt[3]{\frac{n_1}{2000}}}$

³⁾ Maximum momentary torque for emergency stops or heavy shock load. Admissible stops per life of gearhead = 1,000 stops maximum.



"PHQA" Series ServoFit® Precision Planetary Gearhead Selection Data



Part Number (Gearhead + Input)	Exact Ratio i	Maximum Input Speed		Maximum Motor Shaft øD ⁶ mm	Input ¹⁾ Inertia J ₁ kgcm ²	Torsional Stiffness per arcmin C ₂		Output Torque					
		Continuous RPM (n ₁)	Cyclic RPM (n ₂)			in.lbs.	Nm	Nominal ²⁾ M _{2N}		Acceleration M _{2B}		Peak ³⁾ M _{2PEAK}	
								in.lbs.	Nm	in.lbs.	Nm	in.lbs.	Nm

PHQA723 with Motor Mounting Plate *Continued*

PHQA723F2200 MF	220.0	4,000	7,000	≤14	1.70	1,786.5	201.7	5,758	650	8,415	950	16,830	1,900
PHQA723F2200 MF	220.0	4,000	7,000	>14≤19	1.70	1,786.5	201.7	5,758	650	8,415	950	16,830	1,900
PHQA723F2200 MF	220.0	4,000	7,000	>19≤24	1.60	1,786.5	201.7	5,758	650	8,415	950	16,830	1,900
PHQA723F2200 MFL	220.0	4,000	7,000	>24≤32	4.76	1,786.7	201.7	5,758	650	8,415	950	16,830	1,900
PHQA723F2750 MF	275.0	4,000	7,000	≤14	1.70	1,791.0	202.2	5,758	650	8,415	950	16,830	1,900
PHQA723F2750 MF	275.0	4,000	7,000	>14≤19	1.70	1,791.0	202.2	5,758	650	8,415	950	16,830	1,900
PHQA723F2750 MF	275.0	4,000	7,000	>19≤24	1.60	1,791.0	202.2	5,758	650	8,415	950	16,830	1,900
PHQA723F2750 MFL	275.0	4,000	7,000	>24≤32	4.76	1,791.1	202.2	5,758	650	8,415	950	16,830	1,900
PHQA723F3850 MF	385.0	4,000	7,000	≤14	1.69	1,779.0	200.8	5,758	650	8,415	950	16,830	1,900
PHQA723F3850 MF	385.0	4,000	7,000	>14≤19	1.69	1,779.0	200.8	5,758	650	8,415	950	16,830	1,900
PHQA723F3850 MF	385.0	4,000	7,000	>19≤24	1.59	1,779.0	200.8	5,758	650	8,415	950	16,830	1,900
PHQA723F3850 MFL	385.0	4,000	7,000	>24≤32	4.75	1,779.1	200.8	5,758	650	8,415	950	16,830	1,900
PHQA723F5500 MF	550.0	4,000	7,000	≤14	1.69	1,723.4	194.6	5,758	650	8,415	950	16,830	1,900
PHQA723F5500 MF	550.0	4,000	7,000	>14≤19	1.69	1,723.4	194.6	5,758	650	8,415	950	16,830	1,900
PHQA723F5500 MF	550.0	4,000	7,000	>19≤24	1.59	1,723.4	194.6	5,758	650	8,415	950	16,830	1,900
PHQA723F5500 MFL	550.0	4,000	7,000	>24≤32	4.75	1,723.5	194.6	5,758	650	8,415	950	16,830	1,900

PHQA822 with Motor Mounting Plate

PHQA822F0220 MF	22.00	2,500	4,500	≤24	16.11	5,615.5	633.9	15,059	1,700	23,031	2,600	38,975	4,400
PHQA822F0220 MF	22.00	2,500	4,500	>24≤32	16.44	5,661.8	639.2	15,059	1,700	23,031	2,600	38,975	4,400
PHQA822F0220 MF	22.00	2,500	4,500	>32≤38	16.44	5,661.8	639.2	15,059	1,700	23,031	2,600	38,975	4,400
PHQA822F0220 MFL	22.00	2,500	4,500	>38≤48	18.46	5,749.0	649.0	15,059	1,700	23,031	2,600	38,975	4,400
PHQA822F0280 MF	27.50	3,000	5,500	≤24	14.36	5,657.5	638.7	15,059	1,700	23,031	2,600	38,975	4,400
PHQA822F0280 MF	27.50	3,000	5,500	>24≤32	14.69	5,687.5	642.1	15,059	1,700	23,031	2,600	38,975	4,400
PHQA822F0280 MF	27.50	3,000	5,500	>32≤38	14.69	5,687.5	642.1	15,059	1,700	23,031	2,600	38,975	4,400
PHQA822F0280 MFL	27.50	3,000	5,500	>38≤48	16.71	5,743.5	648.4	15,059	1,700	23,031	2,600	38,975	4,400
PHQA822F0390 MF	38.50	3,300	6,000	≤24	12.98	5,619.5	634.4	15,059	1,700	23,031	2,600	38,975	4,400
PHQA822F0390 MF	38.50	3,300	6,000	>24≤32	12.98	5,619.5	634.4	15,059	1,700	23,031	2,600	38,975	4,400
PHQA822F0390 MF	38.50	3,300	6,000	>32≤38	12.98	5,619.5	634.4	15,059	1,700	23,031	2,600	38,975	4,400
PHQA822F0390 MFL	38.50	3,300	6,000	>38≤48	15.35	5,656.7	638.6	15,059	1,700	23,031	2,600	38,975	4,400
PHQA822F0550 MF	55.00	3,300	6,000	≤24	12.31	5,413.3	611.1	14,031	1,584	23,031	2,600	38,975	4,400
PHQA822F0550 MF	55.00	3,300	6,000	>24≤32	12.31	5,413.3	611.1	14,031	1,584	23,031	2,600	38,975	4,400
PHQA822F0550 MF	55.00	3,300	6,000	>32≤38	12.31	5,413.3	611.1	14,031	1,584	23,031	2,600	38,975	4,400
PHQA822F0550 MFL	55.00	3,300	6,000	>38≤48	14.68	5,430.1	613.0	14,031	1,584	23,031	2,600	38,975	4,400

PHQA823 with Motor Mounting Plate *Continued Next Page*

PHQA823F0880 MF	88.00	3,000	5,000	≤19	6.12	5,704.6	644.0	15,059	1,700	23,031	2,600	38,975	4,400
PHQA823F0880 MF	88.00	3,000	5,000	>19≤24	6.19	5,709.4	644.6	15,059	1,700	23,031	2,600	38,975	4,400
PHQA823F0880 MF	88.00	3,000	5,000	>24≤32	6.09	5,709.4	644.6	15,059	1,700	23,031	2,600	38,975	4,400
PHQA823F0880 MF	88.00	3,000	5,000	>32≤35	6.09	5,709.4	644.6	15,059	1,700	23,031	2,600	38,975	4,400
PHQA823F0880 MFL	88.00	3,000	5,000	>32≤38	13.28	5,719.2	645.7	15,059	1,700	23,031	2,600	38,975	4,400
PHQA823F1100 MF	110.0	3,500	6,000	≤19	6.01	5,714.2	645.1	15,059	1,700	23,031	2,600	38,975	4,400
PHQA823F1100 MF	110.0	3,500	6,000	>19≤24	6.08	5,717.2	645.4	15,059	1,700	23,031	2,600	38,975	4,400
PHQA823F1100 MF	110.0	3,500	6,000	>24≤32	5.98	5,717.2	645.4	15,059	1,700	23,031	2,600	38,975	4,400

Index of Symbols: **MT** — Motor adapter with TriAdapt® coupling; **MF** — Motor adapter with FlexiAdapt® coupling; **L** — Large Input; **C** — ServoCool

See Page 142 for Options and Part Number Configuration.



"PHQA" Series ServoFit® Precision Planetary Gearhead Selection Data



Part Number (Gearhead + Input)	Exact Ratio i	Maximum Input Speed		Maximum Motor Shaft øD ⁶ mm	Input ¹⁾ Inertia J ₁ kgcm ²	Torsional Stiffness per arcmin		Output Torque					
		Continuous RPM (n ₁)	Cyclic RPM (n ₁)			C ₂	Nominal ²⁾		Acceleration		Peak ³⁾		
							M _{2N}	M _{2B}	M _{2B}	M _{2PEAK}			
Gearhead						in.lbs.	Nm	in.lbs.	Nm	in.lbs.	Nm	in.lbs.	Nm
PHQA823 with Motor Mounting Plate <i>Continued</i>													
PHQA823F1100 MF	110.0	3,500	6,000	>32≤35	5.98	5,717.2	645.4	15,059	1,700	23,031	2,600	38,975	4,400
PHQA823F1100 MFL	110.0	3,500	6,000	>32≤38	13.17	5,723.5	646.1	15,059	1,700	23,031	2,600	38,975	4,400
PHQA823F1380 MF	137.5	3,500	6,000	≤19	5.53	5,711.4	644.8	15,059	1,700	23,031	2,600	38,975	4,400
PHQA823F1380 MF	137.5	3,500	6,000	>19≤24	5.60	5,713.4	645.0	15,059	1,700	23,031	2,600	38,975	4,400
PHQA823F1380 MF	137.5	3,500	6,000	>24≤32	5.50	5,713.4	645.0	15,059	1,700	23,031	2,600	38,975	4,400
PHQA823F1380 MF	137.5	3,500	6,000	>32≤35	5.50	5,713.4	645.0	15,059	1,700	23,031	2,600	38,975	4,400
PHQA823F1380 MFL	137.5	3,500	6,000	>32≤38	12.69	5,717.4	645.4	15,059	1,700	23,031	2,600	38,975	4,400
PHQA823F1540 MF	154.0	3,700	6,500	≤19	5.21	5,704.8	644.0	15,059	1,700	23,031	2,600	38,975	4,400
PHQA823F1540 MF	154.0	3,700	6,500	>19≤24	5.21	5,704.8	644.0	15,059	1,700	23,031	2,600	38,975	4,400
PHQA823F1540 MF	154.0	3,700	6,500	>24≤32	5.11	5,704.8	644.0	15,059	1,700	23,031	2,600	38,975	4,400
PHQA823F1540 MF	154.0	3,700	6,500	>32≤35	5.11	5,704.8	644.0	15,059	1,700	23,031	2,600	38,975	4,400
PHQA823F1540 MFL	154.0	3,700	6,500	>32≤38	12.04	5,708.6	644.5	15,059	1,700	23,031	2,600	38,975	4,400
PHQA823F1930 MF	192.5	3,700	6,500	≤19	5.18	5,707.9	644.4	15,059	1,700	23,031	2,600	38,975	4,400
PHQA823F1930 MF	192.5	3,700	6,500	>19≤24	5.18	5,707.9	644.4	15,059	1,700	23,031	2,600	38,975	4,400
PHQA823F1930 MF	192.5	3,700	6,500	>24≤32	5.08	5,707.9	644.4	15,059	1,700	23,031	2,600	38,975	4,400
PHQA823F1930 MF	192.5	3,700	6,500	>32≤35	5.08	5,707.9	644.4	15,059	1,700	23,031	2,600	38,975	4,400
PHQA823F1930 MFL	192.5	3,700	6,500	>32≤38	12.01	5,710.3	644.6	15,059	1,700	23,031	2,600	38,975	4,400
PHQA823F2200 MF	220.0	3,700	6,500	≤19	5.01	5,673.8	640.5	15,059	1,700	23,031	2,600	38,975	4,400
PHQA823F2200 MF	220.0	3,700	6,500	>19≤24	5.01	5,673.8	640.5	15,059	1,700	23,031	2,600	38,975	4,400
PHQA823F2200 MF	220.0	3,700	6,500	>24≤32	4.91	5,673.8	640.5	15,059	1,700	23,031	2,600	38,975	4,400
PHQA823F2200 MF	220.0	3,700	6,500	>32≤35	4.91	5,673.8	640.5	15,059	1,700	23,031	2,600	38,975	4,400
PHQA823F2200 MFL	220.0	3,700	6,500	>32≤38	11.84	5,675.6	640.7	15,059	1,700	23,031	2,600	38,975	4,400
PHQA823F2750 MF	275.0	3,700	6,500	≤19	4.99	5,693.0	642.7	15,059	1,700	23,031	2,600	38,975	4,400
PHQA823F2750 MF	275.0	3,700	6,500	>19≤24	4.99	5,693.0	642.7	15,059	1,700	23,031	2,600	38,975	4,400
PHQA823F2750 MF	275.0	3,700	6,500	>24≤32	4.89	5,693.0	642.7	15,059	1,700	23,031	2,600	38,975	4,400
PHQA823F2750 MF	275.0	3,700	6,500	>32≤35	4.89	5,693.0	642.7	15,059	1,700	23,031	2,600	38,975	4,400
PHQA823F2750 MFL	275.0	3,700	6,500	>32≤38	11.82	5,694.2	642.8	15,059	1,700	23,031	2,600	38,975	4,400
PHQA823F3850 MF	385.0	3,700	6,500	≤19	4.98	5,623.5	634.8	15,059	1,700	23,031	2,600	38,975	4,400
PHQA823F3850 MF	385.0	3,700	6,500	>19≤24	4.98	5,623.5	634.8	15,059	1,700	23,031	2,600	38,975	4,400
PHQA823F3850 MF	385.0	3,700	6,500	>24≤32	4.88	5,623.5	634.8	15,059	1,700	23,031	2,600	38,975	4,400
PHQA823F3850 MF	385.0	3,700	6,500	>32≤35	4.88	5,623.5	634.8	15,059	1,700	23,031	2,600	38,975	4,400
PHQA823F3850 MFL	385.0	3,700	6,500	>32≤38	11.80	5,624.1	634.9	15,059	1,700	23,031	2,600	38,975	4,400
PHQA823F5500 MF	550.0	3,700	6,500	≤19	4.97	5,411.6	610.9	14,031	1,584	23,031	2,600	38,975	4,400
PHQA823F5500 MF	550.0	3,700	6,500	>19≤24	4.97	5,411.6	610.9	14,031	1,584	23,031	2,600	38,975	4,400
PHQA823F5500 MF	550.0	3,700	6,500	>24≤32	4.87	5,411.6	610.9	14,031	1,584	23,031	2,600	38,975	4,400
PHQA823F5500 MF	550.0	3,700	6,500	>32≤35	4.87	5,411.6	610.9	14,031	1,584	23,031	2,600	38,975	4,400
PHQA823F5500 MFL	550.0	3,700	6,500	>32≤38	11.80	5,411.9	611.0	14,031	1,584	23,031	2,600	38,975	4,400

¹⁾ Inertia based on maximum input. For lower inertia using smaller diameter input, contact STOBER.

²⁾ Based on input speed: n₁ = 2000 RPM. For torque at higher input speeds (M_{2NX}) solve the formula, where n₁ = Actual Input Speed. $M_{2NX} = \frac{M_{2N}}{\sqrt[3]{\frac{n_1}{2000}}}$

³⁾ Maximum momentary torque for emergency stops or heavy shock load. Admissible stops per life of gearhead = 1,000 stops maximum.



"PHQA" Series ServoFit® Precision Planetary Gearhead Selection Data



Part Number (Gearhead + Input)	Exact Ratio i	Maximum Input Speed		Maximum Motor Shaft øD ⁶ mm	Input ¹⁾ Inertia J ₁ kgcm ²	Torsional Stiffness per arcmin C ₂		Output Torque					
		Continuous RPM (n ₁)	Cyclic RPM (n ₂)			Nominal ²⁾ M _{2N}		Acceleration M _{2B}		Peak ³⁾ M _{2PEAK}			
						in.lbs.	Nm	in.lbs.	Nm	in.lbs.	Nm		

PHQA932 with Motor Mounting Plate

PHQA932F0180 MF	18.00	1,800	3,000	≤32	78.11	10,334.8	1,166.7	33,660	3,800	53,148	6,000	75,179	8,487
PHQA932F0180 MF	18.00	1,800	3,000	>32≤38	77.88	10,423.3	1,176.7	33,660	3,800	53,148	6,000	89,266	10,077
PHQA932F0180 MF	18.00	1,800	3,000	>38≤48	77.25	10,423.3	1,176.7	33,660	3,800	53,148	6,000	106,296	12,000
PHQA932F0240 MF	24.00	2,200	3,500	≤32	49.34	10,496.9	1,185.0	33,660	3,800	53,148	6,000	100,239	11,316
PHQA932F0240 MF	24.00	2,200	3,500	>32≤38	49.12	10,548.1	1,190.8	33,660	3,800	53,148	6,000	106,296	12,000
PHQA932F0240 MF	24.00	2,200	3,500	>38≤48	48.48	10,548.1	1,190.8	33,660	3,800	53,148	6,000	106,296	12,000
PHQA932F0300 MF	30.00	2,500	4,000	≤32	42.43	10,527.5	1,188.5	33,660	3,800	53,148	6,000	106,296	12,000
PHQA932F0300 MF	30.00	2,500	4,000	>32≤38	42.20	10,560.4	1,192.2	33,660	3,800	53,148	6,000	106,296	12,000
PHQA932F0300 MF	30.00	2,500	4,000	>38≤48	41.57	10,560.4	1,192.2	33,660	3,800	53,148	6,000	106,296	12,000
PHQA932F0420 MF	42.00	2,800	4,500	≤32	37.04	10,468.4	1,181.8	33,660	3,800	53,148	6,000	106,296	12,000
PHQA932F0420 MF	42.00	2,800	4,500	>32≤38	36.84	10,468.4	1,181.8	33,660	3,800	53,148	6,000	106,296	12,000
PHQA932F0420 MF	42.00	2,800	4,500	>38≤48	36.20	10,468.4	1,181.8	33,660	3,800	53,148	6,000	106,296	12,000
PHQA932F0600 MF	60.00	2,800	4,500	≤32	34.33	10,129.5	1,143.5	33,660	3,800	53,148	6,000	106,296	12,000
PHQA932F0600 MF	60.00	2,800	4,500	>32≤38	34.12	10,129.5	1,143.5	33,660	3,800	53,148	6,000	106,296	12,000
PHQA932F0600 MF	60.00	2,800	4,500	>38≤48	33.49	10,129.5	1,143.5	33,660	3,800	53,148	6,000	106,296	12,000

P
H
Q
A

PHQA933 with Motor Mounting Plate Continued Next Page

PHQA933F0720 MF	72.00	2,200	4,500	≤24	18.15	10,599.6	1,196.6	33,660	3,800	53,148	6,000	106,296	12,000
PHQA933F0720 MF	72.00	2,200	4,500	>24≤32	18.49	10,614.9	1,198.3	33,660	3,800	53,148	6,000	106,296	12,000
PHQA933F0720 MF	72.00	2,200	4,500	>32≤38	18.49	10,614.9	1,198.3	33,660	3,800	53,148	6,000	106,296	12,000
PHQA933F0720 MFL	72.00	2,200	4,500	>38≤48	20.50	10,643.2	1,201.5	33,660	3,800	53,148	6,000	106,296	12,000
PHQA933F0960 MF	96.00	2,500	4,500	≤24	16.35	10,649.0	1,202.2	33,660	3,800	53,148	6,000	106,296	12,000
PHQA933F0960 MF	96.00	2,500	4,500	>24≤32	16.69	10,657.6	1,203.2	33,660	3,800	53,148	6,000	106,296	12,000
PHQA933F0960 MF	96.00	2,500	4,500	>32≤38	16.69	10,657.6	1,203.2	33,660	3,800	53,148	6,000	106,296	12,000
PHQA933F0960 MFL	96.00	2,500	4,500	>38≤48	18.70	10,673.7	1,205.0	33,660	3,800	53,148	6,000	106,296	12,000
PHQA933F1200 MF	120.0	2,500	4,500	≤24	15.92	10,624.8	1,199.5	33,660	3,800	53,148	6,000	106,296	12,000
PHQA933F1200 MF	120.0	2,500	4,500	>24≤32	16.26	10,630.4	1,200.1	33,660	3,800	53,148	6,000	106,296	12,000
PHQA933F1200 MF	120.0	2,500	4,500	>32≤38	16.26	10,630.4	1,200.1	33,660	3,800	53,148	6,000	106,296	12,000
PHQA933F1200 MFL	120.0	2,500	4,500	>38≤48	18.27	10,640.5	1,201.2	33,660	3,800	53,148	6,000	106,296	12,000
PHQA933F1500 MF	150.0	3,000	5,500	≤24	14.24	10,628.8	1,199.9	33,660	3,800	53,148	6,000	106,296	12,000
PHQA933F1500 MF	150.0	3,000	5,500	>24≤32	14.58	10,632.3	1,200.3	33,660	3,800	53,148	6,000	106,296	12,000
PHQA933F1500 MF	150.0	3,000	5,500	>32≤38	14.58	10,632.3	1,200.3	33,660	3,800	53,148	6,000	106,296	12,000
PHQA933F1500 MFL	150.0	3,000	5,500	>38≤48	16.59	10,638.8	1,201.0	33,660	3,800	53,148	6,000	106,296	12,000
PHQA933F1680 MF	168.0	3,300	6,000	≤24	13.06	10,646.5	1,201.9	33,660	3,800	53,148	6,000	106,296	12,000
PHQA933F1680 MF	168.0	3,300	6,000	>24≤32	13.06	10,646.5	1,201.9	33,660	3,800	53,148	6,000	106,296	12,000
PHQA933F1680 MF	168.0	3,300	6,000	>32≤38	13.06	10,646.5	1,201.9	33,660	3,800	53,148	6,000	106,296	12,000
PHQA933F1680 MFL	168.0	3,300	6,000	>38≤48	15.43	10,653.4	1,202.7	33,660	3,800	53,148	6,000	106,296	12,000
PHQA933F2100 MF	210.0	3,300	6,000	≤24	12.92	10,623.2	1,199.3	33,660	3,800	53,148	6,000	106,296	12,000
PHQA933F2100 MF	210.0	3,300	6,000	>24≤32	12.92	10,623.2	1,199.3	33,660	3,800	53,148	6,000	106,296	12,000
PHQA933F2100 MF	210.0	3,300	6,000	>32≤38	12.92	10,623.2	1,199.3	33,660	3,800	53,148	6,000	106,296	12,000
PHQA933F2100 MFL	210.0	3,300	6,000	>38≤48	15.29	10,627.7	1,199.8	33,660	3,800	53,148	6,000	106,296	12,000

Index of Symbols: **MT** — Motor adapter with TriAdapt® coupling; **MF** — Motor adapter with FlexiAdapt® coupling; **L** — Large Input; **C** — ServoCool

See Page 142 for Options and Part Number Configuration.



"PHQA" Series ServoFit® Precision Planetary Gearhead Selection Data



Part Number (Gearhead + Input)	Exact Ratio i	Maximum Input Speed		Maximum Motor Shaft Inertia J ₁ kgcm ²	Input ¹⁾ J ₁ kgcm ²	Torsional Stiffness per arcmin		Output Torque					
		Continuous RPM (n ₁)	Cyclic RPM (n ₁)			C ₂	Nominal ²⁾		Acceleration		Peak ³⁾		
							M _{2N}	M _{2B}	M _{2B}	M _{2PEAK}			

PHQA933 with Motor Mounting Plate *Continued*

PHQA933F2400 MF	240.0	3,300	6,000	≤24	12.35	10,600.9	1,196.8	33,660	3,800	53,148	6,000	106,296	12,000
PHQA933F2400 MF	240.0	3,300	6,000	>24≤32	12.35	10,600.9	1,196.8	33,660	3,800	53,148	6,000	106,296	12,000
PHQA933F2400 MF	240.0	3,300	6,000	>32≤38	12.35	10,600.9	1,196.8	33,660	3,800	53,148	6,000	106,296	12,000
PHQA933F2400 MFL	240.0	3,300	6,000	>38≤48	14.72	10,604.3	1,197.1	33,660	3,800	53,148	6,000	106,296	12,000
PHQA933F3000 MF	300.0	3,300	6,000	≤24	12.28	10,594.2	1,196.0	33,660	3,800	53,148	6,000	106,296	12,000
PHQA933F3000 MF	300.0	3,300	6,000	>24≤32	12.28	10,594.2	1,196.0	33,660	3,800	53,148	6,000	106,296	12,000
PHQA933F3000 MF	300.0	3,300	6,000	>32≤38	12.28	10,594.2	1,196.0	33,660	3,800	53,148	6,000	106,296	12,000
PHQA933F3000 MFL	300.0	3,300	6,000	>38≤48	14.65	10,596.3	1,196.2	33,660	3,800	53,148	6,000	106,296	12,000
PHQA933F4200 MF	420.0	3,300	6,000	≤24	12.22	10,485.8	1,183.8	33,660	3,800	53,148	6,000	106,296	12,000
PHQA933F4200 MF	420.0	3,300	6,000	>24≤32	12.22	10,485.8	1,183.8	33,660	3,800	53,148	6,000	106,296	12,000
PHQA933F4200 MF	420.0	3,300	6,000	>32≤38	12.22	10,485.8	1,183.8	33,660	3,800	53,148	6,000	106,296	12,000
PHQA933F4200 MFL	420.0	3,300	6,000	>38≤48	14.59	10,486.8	1,183.9	33,660	3,800	53,148	6,000	106,296	12,000
PHQA933F6000 MF	600.0	3,300	6,000	≤24	12.20	10,137.5	1,144.4	33,660	3,800	53,148	6,000	106,296	12,000
PHQA933F6000 MF	600.0	3,300	6,000	>24≤32	12.20	10,137.5	1,144.4	33,660	3,800	53,148	6,000	106,296	12,000
PHQA933F6000 MF	600.0	3,300	6,000	>32≤38	12.20	10,137.5	1,144.4	33,660	3,800	53,148	6,000	106,296	12,000
PHQA933F6000 MFL	600.0	3,300	6,000	>38≤48	14.57	10,138.0	1,144.5	33,660	3,800	53,148	6,000	106,296	12,000

PHQA1032 with Motor Mounting Plate

PHQA1032F0240 MT	24.00	2,000	3,000	≤48	90.76	18,268.8	2,062.4	57,577	6,500	88,580	10,000	177,160	20,000
PHQA1032F0240 MT	24.00	2,000	3,000	>48≤55	100.40	18,268.8	2,062.4	57,577	6,500	88,580	10,000	177,160	20,000
PHQA1032F0240 MT	24.00	2,000	3,000	>55≤60	95.79	18,268.8	2,062.4	57,577	6,500	88,580	10,000	177,160	20,000
PHQA1032F0300 MT	30.00	2,200	3,500	≤48	72.20	18,232.6	2,058.3	57,577	6,500	88,580	10,000	177,160	20,000
PHQA1032F0300 MT	30.00	2,200	3,500	>48≤55	81.84	18,232.6	2,058.3	57,577	6,500	88,580	10,000	177,160	20,000
PHQA1032F0300 MT	30.00	2,200	3,500	>55≤60	77.22	18,232.6	2,058.3	57,577	6,500	88,580	10,000	177,160	20,000
PHQA1032F0420 MT	42.00	2,500	4,000	≤48	57.46	18,070.9	2,040.1	57,577	6,500	88,580	10,000	177,160	20,000
PHQA1032F0420 MT	42.00	2,500	4,000	>48≤55	67.10	18,070.9	2,040.1	57,577	6,500	88,580	10,000	177,160	20,000
PHQA1032F0420 MT	42.00	2,500	4,000	>55≤60	62.49	18,070.9	2,040.1	57,577	6,500	88,580	10,000	177,160	20,000
PHQA1032F0600 MT	60.00	2,500	4,000	≤48	50.14	17,454.4	1,970.5	57,577	6,500	88,580	10,000	177,160	20,000
PHQA1032F0600 MT	60.00	2,500	4,000	>48≤55	59.78	17,454.4	1,970.5	57,577	6,500	88,580	10,000	177,160	20,000
PHQA1032F0600 MT	60.00	2,500	4,000	>55≤60	55.17	17,454.4	1,970.5	57,577	6,500	88,580	10,000	177,160	20,000

¹⁾ Inertia based on maximum input. For lower inertia using smaller diameter input, contact STOBER.

²⁾ Based on input speed: n₁ = 2000 RPM. For torque at higher input speeds (M_{2NX}) solve the formula, where n₁ = Actual Input Speed. $M_{2NX} = \frac{M_{2N}}{\sqrt[3]{\frac{n_1}{2000}}}$

³⁾ Maximum momentary torque for emergency stops or heavy shock load. Admissible stops per life of gearhead = 1,000 stops maximum.



"PHQA" Series ServoFit® Precision Planetary Gearhead Selection Data



Part Number (Gearhead + Input)	Exact Ratio i	Maximum Input Speed		Maximum Motor Shaft ØD ⁶ mm	Input ¹⁾ Inertia J ₁ kgcm ²	Torsional Stiffness per arcmin C ₂		Output Torque					
		Continuous RPM (n ₁)	Cyclic RPM (n ₁)			Nominal ²⁾		Acceleration		Peak ³⁾			
						M _{2N}	M _{2B}	M _{2B}	M _{2PEAK}	M _{2PEAK}	M _{2PEAK}		
Gearhead						in.lbs.	Nm	in.lbs.	Nm	in.lbs.	Nm	in.lbs.	Nm
PHQA1033F0960 MT	96.00	2,200	3,500	≤32	28.33	18,255.3	2,060.9	57,577	6,500	88,580	10,000	177,160	20,000
PHQA1033F0960 MT	96.00	2,200	3,500	>32≤38	32.26	18,265.0	2,062.0	57,577	6,500	88,580	10,000	177,160	20,000
PHQA1033F0960 MT	96.00	2,200	3,500	>38≤48	36.00	18,265.0	2,062.0	57,577	6,500	88,580	10,000	177,160	20,000
PHQA1033F0960 MTL	96.00	2,200	3,500	>48≤55	71.29	18,305.1	2,066.5	57,577	6,500	88,580	10,000	177,160	20,000
PHQA1033F0960 MTL	96.00	2,200	3,500	>55≤60	66.68	18,305.1	2,066.5	57,577	6,500	88,580	10,000	177,160	20,000
PHQA1033F1200 MT	120.0	2,200	3,500	≤32	27.17	18,224.0	2,057.3	57,577	6,500	88,580	10,000	177,160	20,000
PHQA1033F1200 MT	120.0	2,200	3,500	>32≤38	31.10	18,230.1	2,058.0	57,577	6,500	88,580	10,000	177,160	20,000
PHQA1033F1200 MT	120.0	2,200	3,500	>38≤48	34.84	18,230.1	2,058.0	57,577	6,500	88,580	10,000	177,160	20,000
PHQA1033F1200 MTL	120.0	2,200	3,500	>48≤55	70.13	18,255.7	2,060.9	57,577	6,500	88,580	10,000	177,160	20,000
PHQA1033F1200 MTL	120.0	2,200	3,500	>55≤60	65.52	18,255.7	2,060.9	57,577	6,500	88,580	10,000	177,160	20,000
PHQA1033F1500 MT	150.0	2,500	4,000	≤32	20.24	18,227.6	2,057.8	57,577	6,500	88,580	10,000	177,160	20,000
PHQA1033F1500 MT	150.0	2,500	4,000	>32≤38	24.17	18,231.6	2,058.2	57,577	6,500	88,580	10,000	177,160	20,000
PHQA1033F1500 MT	150.0	2,500	4,000	>38≤48	27.90	18,231.6	2,058.2	57,577	6,500	88,580	10,000	177,160	20,000
PHQA1033F1500 MTL	150.0	2,500	4,000	>48≤55	63.20	18,247.9	2,060.1	57,577	6,500	88,580	10,000	177,160	20,000
PHQA1033F1500 MTL	150.0	2,500	4,000	>55≤60	58.59	18,247.9	2,060.1	57,577	6,500	88,580	10,000	177,160	20,000
PHQA1033F1680 MT	168.0	2,800	4,500	≤32	15.23	18,261.3	2,061.6	57,577	6,500	88,580	10,000	177,160	20,000
PHQA1033F1680 MT	168.0	2,800	4,500	>32≤38	17.50	18,261.3	2,061.6	57,577	6,500	88,580	10,000	177,160	20,000
PHQA1033F1680 MT	168.0	2,800	4,500	>38≤48	20.79	18,261.3	2,061.6	57,577	6,500	88,580	10,000	177,160	20,000
PHQA1033F1680 MTL	168.0	2,800	4,500	>48≤55	58.19	18,277.6	2,063.4	57,577	6,500	88,580	10,000	177,160	20,000
PHQA1033F2100 MT	210.0	2,800	4,500	≤32	14.85	18,227.8	2,057.8	57,577	6,500	88,580	10,000	177,160	20,000
PHQA1033F2100 MT	210.0	2,800	4,500	>32≤38	17.12	18,227.8	2,057.8	57,577	6,500	88,580	10,000	177,160	20,000
PHQA1033F2100 MT	210.0	2,800	4,500	>38≤48	20.41	18,227.8	2,057.8	57,577	6,500	88,580	10,000	177,160	20,000
PHQA1033F2100 MTL	210.0	2,800	4,500	>48≤55	57.81	18,238.2	2,059.0	57,577	6,500	88,580	10,000	177,160	20,000
PHQA1033F2400 MT	240.0	2,800	4,500	≤32	12.32	18,201.3	2,054.8	57,577	6,500	88,580	10,000	177,160	20,000
PHQA1033F2400 MT	240.0	2,800	4,500	>32≤38	14.59	18,201.3	2,054.8	57,577	6,500	88,580	10,000	177,160	20,000
PHQA1033F2400 MT	240.0	2,800	4,500	>38≤48	17.87	18,201.3	2,054.8	57,577	6,500	88,580	10,000	177,160	20,000
PHQA1033F2400 MTL	240.0	2,800	4,500	>48≤55	55.28	18,209.2	2,055.7	57,577	6,500	88,580	10,000	177,160	20,000
PHQA1033F3000 MT	300.0	2,800	4,500	≤32	12.13	18,189.5	2,053.5	57,577	6,500	88,580	10,000	177,160	20,000
PHQA1033F3000 MT	300.0	2,800	4,500	>32≤38	14.40	18,189.5	2,053.5	57,577	6,500	88,580	10,000	177,160	20,000
PHQA1033F3000 MT	300.0	2,800	4,500	>38≤48	17.69	18,189.5	2,053.5	57,577	6,500	88,580	10,000	177,160	20,000
PHQA1033F3000 MTL	300.0	2,800	4,500	>48≤55	55.09	18,194.5	2,054.0	57,577	6,500	88,580	10,000	177,160	20,000
PHQA1033F4200 MT	420.0	2,800	4,500	≤32	11.99	18,035.2	2,036.0	57,577	6,500	88,580	10,000	177,160	20,000
PHQA1033F4200 MT	420.0	2,800	4,500	>32≤38	14.25	18,035.2	2,036.0	57,577	6,500	88,580	10,000	177,160	20,000
PHQA1033F4200 MT	420.0	2,800	4,500	>38≤48	17.54	18,035.2	2,036.0	57,577	6,500	88,580	10,000	177,160	20,000
PHQA1033F4200 MTL	420.0	2,800	4,500	>48≤55	54.95	18,037.7	2,036.3	57,577	6,500	88,580	10,000	177,160	20,000
PHQA1033F6000 MT	600.0	2,800	4,500	≤32	11.91	17,438.0	1,968.6	57,577	6,500	88,580	10,000	177,160	20,000
PHQA1033F6000 MT	600.0	2,800	4,500	>32≤38	14.18	17,438.0	1,968.6	57,577	6,500	88,580	10,000	177,160	20,000
PHQA1033F6000 MT	600.0	2,800	4,500	>38≤48	17.47	17,438.0	1,968.6	57,577	6,500	88,580	10,000	177,160	20,000
PHQA1033F6000 MTL	600.0	2,800	4,500	>48≤55	54.87	17,439.2	1,968.7	57,577	6,500	88,580	10,000	177,160	20,000

PHQA

Index of Symbols: **MT** — Motor adapter with TriAdapt® coupling; **MF** — Motor adapter with FlexiAdapt® coupling; **L** — Large Input; **C** — ServoCool

See Page 142 for Options and Part Number Configuration.



"PHQA" Series ServoFit® Precision Planetary Gearhead Dimensional Data



Drawing for Units
PHQA722 thru PHQA1033

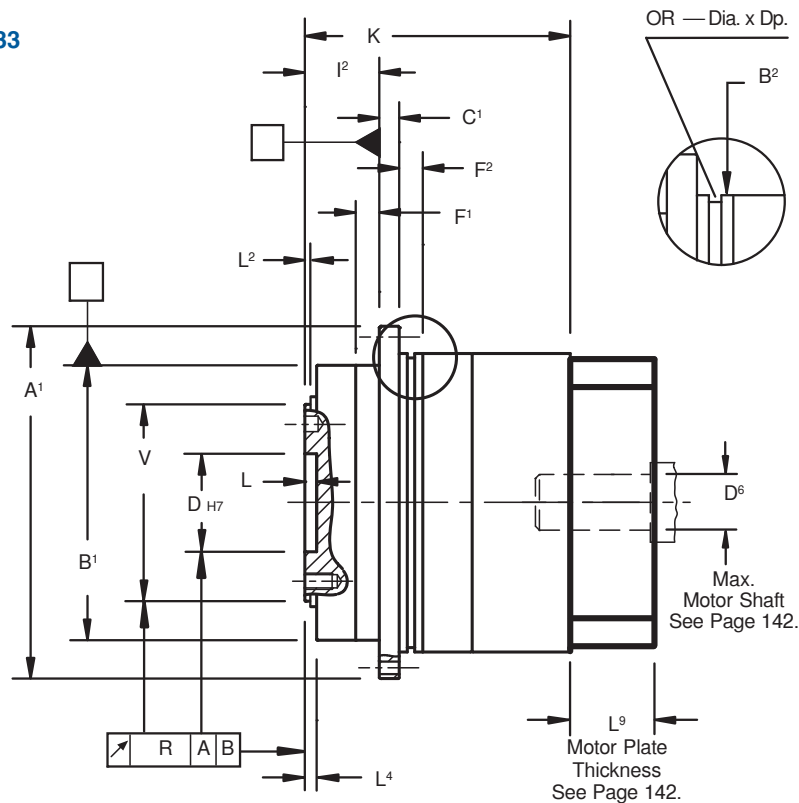

P
H
Q
A

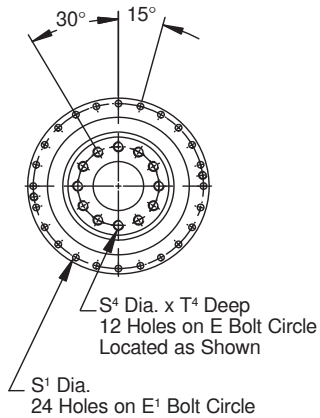

**PHQA7/PHQA8
OUTPUT SIDE**

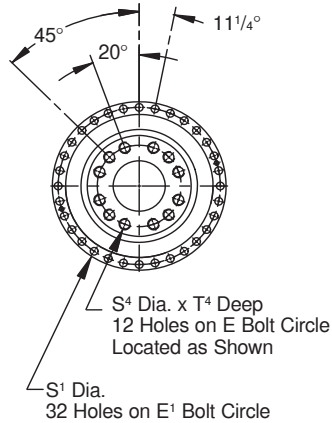

**PHQA9/PHQA10
OUTPUT SIDE**

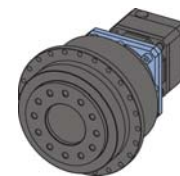

Typical 3 Stage Configuration

Part No. Example
PHQA822F0050MF

Specify: Mounting Position (if third stage)
B² Side Mounting, if required
Paint, if not *Black*
Motor Information



"PHQA" Series ServoFit® Precision Planetary Gearhead Dimensional Data



Table No. 1 "PHQA" Series – Gearhead with Motor Plate – Dimensions (mm)

Unit	A ¹	B ¹	B ²	C ¹	D	E	E ¹	F ¹	F ²	I ²	L	L ²	L ⁴	OR
PHQA722/PHQA723	179 _{h7}	140 _{h7}	152 _{h7}	10	50 _{H6}	80	168	12	12	38	6	6	6	145x3
PHQA822/PHQA823	247 _{h7}	200 _{h7}	212 _{h7}	12	80 _{H6}	125	233	15	15	50	8	8	8.5	200x5
PHQA932/PHQA933	300	255 _{h7}	255 _{h7}	18	90 _{H6}	145	280	20	33	66	12	11	12	238x5
PHQA1032/PHQA1033	330	285 _{h7}	285 _{h7}	20	95 _{H6}	166	310	20	20	75	10	15	15	270x6

Table No. 2 "PHQA" – Dimensions (mm)

Unit	R	S ¹	S ⁴	T ⁴	V
PHQA722/PHQA723	.025	6.6	M10	16	100 _{h7}
PHQA822/PHQA823	.030	9	M12	17	160 _{h7}
PHQA932/PHQA933	.030	13.5	M20	28	180 _{h7}
PHQA1032/PHQA1033	.040	13.5	M24	35	200 _{h7}

If a planetary gearhead is to be mounted from "B²" side, specify when ordering. For proper mounting the paint must be eliminated and the tolerance held on that surface.



Side "B²" mounting is not possible with the Large Input.

Table No. 3 Dimensions (mm)

Unit	Standard		Large Input		
	A ⁵	K	Unit	A ⁵	K
PHQA722	115	190	PHQA722_L	145	206
PHQA723	100	239.5	PHQA723_L	115	248
PHQA822	145	253	PHQA822_L	190	269
PHQA823	115	303	PHQA823_L	145	319
PHQA932	190	350.5	PHQA932_L	225	357.5
PHQA933	145	419	PHQA933_L	190	435
PHQA1032	225	415	–	–	–
PHQA1033	190	503	PHQA1033_L	225	511

PHQA

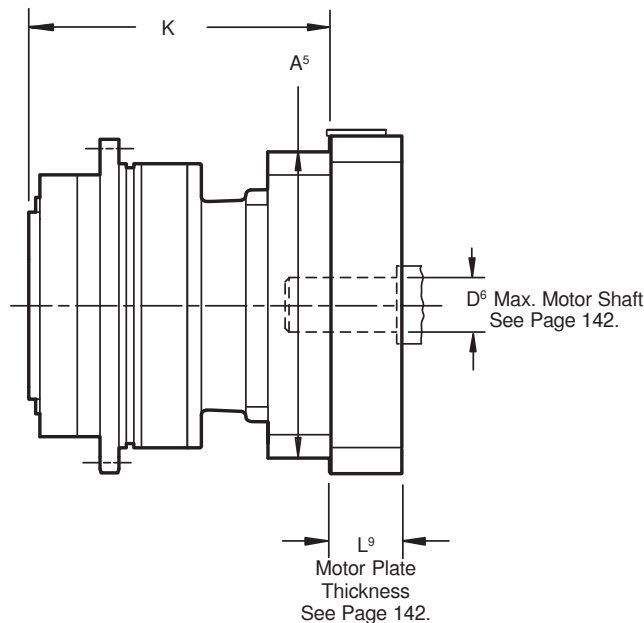

**Drawing for Large Input Units
PHQA722_L thru PHQA1033_L**

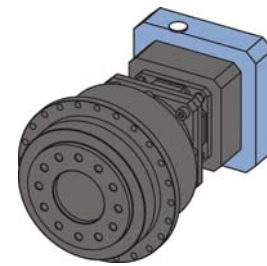

Typical Large Input Configuration

See Page 142 for Options and Part Number Configuration.

"PHQK" Series – Right Angle ServoFit® Precision Planetary Gearhead Performance Specifications



			PHQ7_K2	PHQ8_K4	PHQ9_K5	PH10_K7	PHQ11_K8
Acceleration Torque Maximum	M2B	in.lbs. Nm	8,408 950	23,010 2,600	50,976 5,760	88,500 10,000	194,700 22,000
Output Torque Nominal	M2N	in.lbs. Nm	5,753 650	15,045 1,700	33,630 3,800	57,525 6,500	115,050 13,000
Input Speed Maximum	n1MAX	Continuous Cyclic	4,000 5,500	3,500 5,000	3,400 4,500	2,900 3,800	2,800 3,600
Torsional Backlash ¹⁾	$\Delta\phi$	arcmin	≤4	≤3.5	≤4	≤4	≤4
Torsional Stiffness Maximum	C2	in.lbs./arcmin Nm/arcmin	1,200 135	3,513 397	6,806 769	13,788 1,558	23,169 2,618
Axial Load Maximum	F2AMAX	lbs. N	1,384 6,150	2,261 10,050	7,425 33,000	11,250 50,000	13,500 60,000
Tilting Moment ²⁾	M2K	in.lbs. Nm	13,275 1,500	30,975 3,500	66,375 7,500	77,880 8,800	97,350 11,000
Weight	m	pounds kg	67 30.4	157 71.1	213 96.7	345 156.6	672 304.6
Noise Level ³⁾	LPA	dB(A)	≤63	≤63	≤64	≤64	≤65
Efficiency at Nominal Torque	η	%	≥93 - 96				
Mounting	Must be Specified. See page 154.						
Lubrication	Synthetic Oil (ISO VG 150)						
Ambient Temperature	0° C to +40°C (104° F) [Unit temperature ≤ 90° C Max.]						
Finish	Black (RAL 9005)						
Bearing Lifetime ⁴⁾	Lh	hours	Lh > 10,000 hours if M2K/M2A < 1.25 and > 1.00 Lh > 20,000 hours if M2K/M2A > 1.25 and < 1.50 Lh > 30,000 hours if M2K/M2A > 1.5				
Warranty	5 Year Limited (2 Years on normal wear items: bearings, seals, etc.)						

- ¹⁾ Tested at 1.5% of nominal torque and recorded on the output side of the gearhead.
- ²⁾ Rating based on output speed (n2) of 100 RPM. For values at other speeds see Page 155.
- ³⁾ Measurement at one (1) meter distance with input speed (n1) of 2000 RPM.
- ⁴⁾ M2A equals actual tilting moment of the application. See Page 155 for calculation details.

WARNING: In order to insure that the specified torque ratings are attained, it is essential to attach the gear units to the machine with a grade 12.9 fastener.

Refer to Page 302 for ServoFit Precision Planetary Gearhead Selection Procedure.

PHQK



"PHQK" Series – Right Angle ServoFit® Precision Planetary Gearhead Features

The "PHQK" Series combines the "PHQ" Series ServoFit Precision Planetary Gearheads with a reduced backlash SMS right angle Series "K" to provide a configuration that is a smooth, precise, and reliable drive with the benefit of direct mounting to many types of equipment without a coupling. All units are lubricated for life with synthetic oil and sealed to IP65 standards to prevent lubricant contamination for long life.

Some features are:

- High Axial Load Capacity
- Superior Torsional Stiffness
- Low Backlash
- Low Noise
- High Input Speed
- Advanced Helical Gear Technology
- Ratios up to 591:1
- Compact
- Wide Selection of IEC, NEMA, or Customized Motor Wide Plates
- 5 Year Limited Warranty (2 Year on bearings, seals, etc.)

The patented motor coupling is designed to allow thermal expansion of the motor shaft — ensuring long motor life by preventing thrust load on the motor bearings.

The motor shaft adapter system allows installation of motor in minutes — no special tools required

Motor plate can easily be changed to fit your choice of motors

Adapter bushings to fit all motor shafts — no key required

Motor plate pilot toleranced to fit your motor for precise concentricity

Ring gear machined integral to the housing — not welded or pressed in — provides greater concentricity and more precise alignment

Blind pilot hole

The output flange dimensions are ISO 9409 and allow easy mounting to rotary or indexing tables, pinions, timing belt pulleys, transmission shafting, etc., without using a coupling.

FKM double-lip radial oil seals for continuous duty applications and very good chemical resistance.

HeliCamber® gear technology provides minimum wear, low backlash, and low noise

Highly efficient spiral bevel gearsets provide quiet operation and excellent torque carrying capacity.

Oversized tapered roller bearings and shafts for high radial load capacity and superior torsional stiffness

PHQK

"PHQK" Series – Right Angle ServoFit® Precision Planetary Gearhead



Part No. Explanation

PHQ 7 2 1 F 0055 K202VF 0060 MT20

Series	Unit No.	Generation	No. of Stages	Output Flange	Ratio of PH	Right Angle	Ratio of Right Angle	Input
Series	PHQ	ServoFit Precision Planetary Gearhead						
Size	7	7, 8, 9, 10, 11						
Generation	2	Generation No.						
No. of Stages	1	1 = 1 Stage, 2 = 2 Stage)						
Housing Style	F	Standard Output Flange Mounting						
Ratio	0055	Approximate: 0055 = 5.5:1						
Right Angle Unit	K202VF	Series K202 Helical Bevel with shaft (V) and flange (F)						
Ratio	0060	Approximate: 0060 = 6.00:1 (4:1 to 99:1)						
Motor Adapter	MT20	TriAdapt Motor Adapter MT10, MT20 , MT30, MT40, MT50						

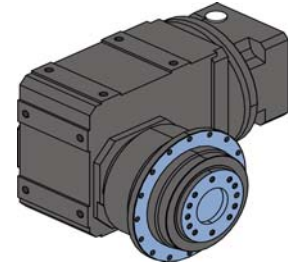

PHQK

Motor information must be specified.

Motor Mounting Specifications

STOBER ServoFit Gearheads will fit the motor of your choice by assembling the correct motor mounting plate between the motor and the gearhead. **When ordering a gearhead, specify the motor manufacturer and part number, provide the motor drawing with dimensions, or specify the motor mounting dimensions.** The motor plate thickness (L⁹) dimension will be determined by the motor shaft length. The minimum motor plate thickness is shown below. For a precise dimension on a specific motor, contact STOBER Technical Support.

The following dimensions are required to provide the correct motor mounting plate:

- D⁶ Motor Shaft Diameter (If an adapter bushing is required it will be supplied with the motor plate.)
- D⁷ Pilot Diameter
- D⁸ Bolt Circle Diameter
- D⁹ Bolt Diameter
- L¹¹ Motor Shaft Length
- L¹² Pilot Length
- L¹⁴ Square Flange (Optional — Motor plate will typically be made to match.)

Table No.1

Input Option	Shaft D ⁶ Max.	Motor Plate Thickness L ⁹ Min.
MT10	19	21
MT20	24	24
MT30	38	25
MT40	48	33
MT50	60	43

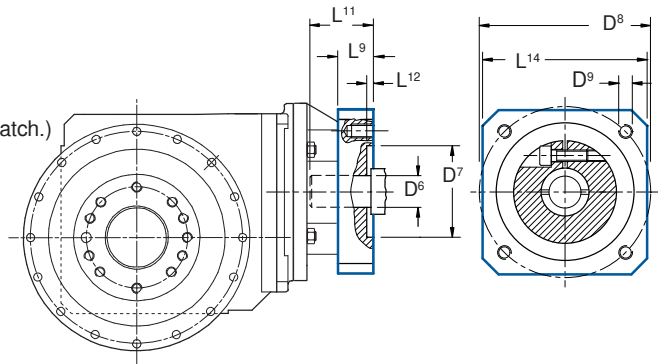

Mounting Position

All ServoFit Precision Planetary units are filled with synthetic oil and lubricated for life. The units should never be opened or the oil changed. All ServoFit Modular System units are shipped filled with the required amount of Mobilgear XP600 lubrication. In order to provide the proper lubrication quantity **the mounting position must be specified at the time the unit is ordered.**

PHQ7K2 – PHQ8K4

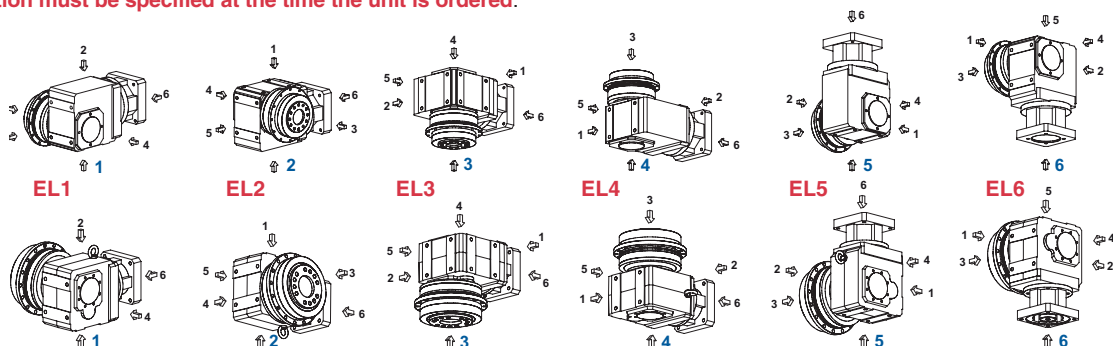

PHQ9K5 – PHQ11K8

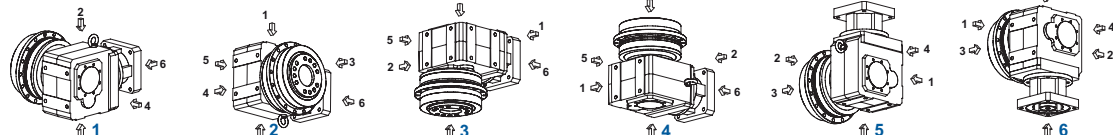



"PHQK" Series – Right Angle ServoFit® Precision Planetary Gearhead Performance Specifications

he "PHQ" Series planetary unit can be mounted on the left or right side of the K Series unit. **Side 3 or Side 4 must be specified on the order.**

PHQ7K2 – PHQ8K4

PHQ9K5 – PHQ11K8

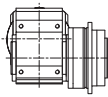
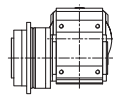

Side 3

Side 4

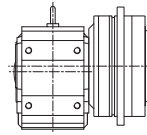
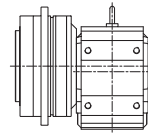

Side 3

Side 4

Viewed from Side 5, EL1 Mounting Position

Maintenance

With STOBER reducers very little maintenance is required under normal operating conditions. Units supplied without breathers are lubricated for life. Units K1 through K3 in the PHK Series do not have breathers.

Direction of Rotation

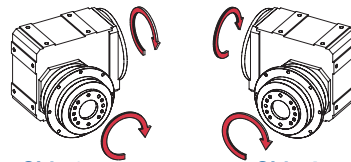

Side 3

Side 4

EL1 Mounting Position, Input CCW

Permissible Output Load and Tilting Moments

The permissible load and tilting moment values are based on an output speed of 100 RPM. For higher speeds the following applies, where n_2 is the desired speed:

$$F_{2AX} = \frac{F_{2A}}{\sqrt[3]{\frac{n_2}{100}}} \quad M_{2KX} = \frac{M_{2K}}{\sqrt[3]{\frac{n_2}{100}}}$$

The application input tilting moment should be determined by the following formula:

$$M_{2A} = \frac{F_{2a} \cdot y_2 + F_{2rb} \cdot (X_2 + Z_2)}{1000} \leq M_{2KB}$$

$$M_{2ka} = \sqrt[3]{\frac{n_{2b1} \cdot t_{b1} \cdot M_{2kb1}^3 + \dots + n_{2bn} \cdot t_{bn} \cdot M_{2kbn}^3}{n_{2b1} \cdot t_{b1} + \dots + n_{2bn} \cdot t_{bn}}} \leq M_{2K}$$

$$F_{2r} = \sqrt[3]{\frac{n_{2b1} \cdot t_{b1} \cdot F_{2rb1}^3 + \dots + n_{2bn} \cdot t_{bn} \cdot F_{2rbn}^3}{n_{2b1} \cdot t_{b1} + \dots + n_{2bn} \cdot t_{bn}}} \leq F_{2R}$$

- where:
- F_{2a} Axial Load at Output Shaft
 - F_{2A} Permissible Axial Load
 - F_{2r} Radial Load at Output Shaft
 - F_{2R} Permissible Radial Load
 - F_{2RB} Acceleration Permissible Radial Load
 - M_{2K} Rated Tilting Torque
 - M_{2k} Equivalent Tilting Load
 - M_{2KB} Acceleration Tilting Torque
 - Z_2 Distance Factor

The hours of life (L_h) of the unit can be determined by the following formula:

bearing life for duty cycle $\leq 40\%$

- $L_h > 10,000$ hours if $M_{2K}/M_{2A} < 1.25$ and > 1
- $L_h > 20,000$ hours if $M_{2K}/M_{2A} > 1.25$ and > 1.5
- $L_h > 30,000$ hours if $M_{2K}/M_{2A} < 1.5$

bearing life for duty cycle $\geq 40\%$

$$L_{hA} = L_h \left(\frac{40\%}{\text{Duty Cycle}} \right)$$

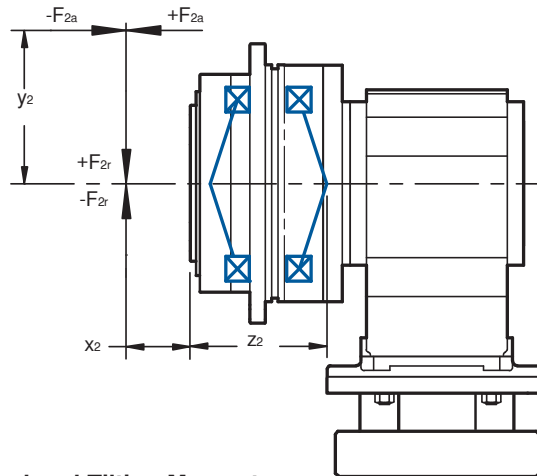

Table No. 2 Permissible Output Load and Tilting Moments

Unit No.	Z_2		F_{2AMAX}		F_{2R}		F_{2RB}		M_{2K}		M_{2KB}		C_{2K}	
	mm	inches	N	lbs.	N	lbs.	N	lbs.	Nm	in.lbs.	Nm	in.lbs.	Nm/arcmin	In.lbs/arcmin
PHQ7K	88	3.46	6,150	1,384	17,045	3,835	17,045	3,835	1,500	13,275	1,500	13,275	500	4,425
PHQ8K	126	4.96	10,050	2,261	27,778	6,250	27,778	6,250	3,500	30,975	3,500	30,975	1,550	13,718
PHQ9K	155	6.10	33,000	7,425	48,387	10,887	70,968	15,938	7,500	66,375	11,000	97,350	7,500	66,375
PHQ10K	171	6.73	50,000	11,250	51,462	11,579	73,099	16,447	8,800	77,880	12,500	110,625	9,500	84,075
PHQ11K	231	9.09	60,000	13,500	47,619	10,714	60,606	13,636	11,000	97,350	14,000	123,900	9,500	84,075

During EMERGENCY OFF operation (maximum stops per gearhead = 1000) the permissible values in the table for F_{2A} , F_{2R} , and M_{2K} can be multiplied by a factor of 2.



"PHQK" Series – Right Angle ServoFit® Precision Planetary Gearhead Selection Data



Part Number	Reducer Ratio i		Input RPM Maximum			Backlash arcmins Δφ	Input Inertia J ₁ kgcm ²	Torsional Stiffness per arcmin C ₂ Nm	Output Torque			
			Continuous		Cyclic				Nominal ¹⁾ M _{2N ≤ 2000 RPM} Nm	Acceleration M _{2B} Nm	Peak ²⁾ M _{2PEAK} Nm	
	Nom.	Exact	n _{1DBH}	n _{1DBV}	n _{1ZB}				M _{2N}	M _{2B}	M _{2PEAK}	
PHQ721_K202 with Motor Mounting Plate Continued Next Page												
PHQ721F0055 K202VF0040 MT10	22.00	22/1	3,000	2,600	4,000	4	3.16	89.9	246	246	333	
PHQ721F0055 K202VF0040 MT20	22.00	22/1	3,000	2,600	4,000	4	3.76	93.0	545	901	1,434	
PHQ721F0055 K202VF0040 MT30	22.00	22/1	3,000	2,600	4,000	4	8.56	105.8	545	921	1,667	
PHQ721F0055 K202VF0044 MT10	24.00	24/1	3,000	2,600	4,000	4	2.81	95.1	268	268	364	
PHQ721F0055 K202VF0044 MT20	24.00	24/1	3,000	2,600	4,000	4	3.41	98.0	561	948	1,565	
PHQ721F0055 K202VF0044 MT30	24.00	24/1	3,000	2,600	4,000	4	8.21	109.7	561	948	1,700	
PHQ721F0055 K202VF0052 MT20	28.47	2107/74	3,000	2,600	4,000	4	2.92	106.6	594	950	1,700	
PHQ721F0055 K202VF0052 MT30	28.47	2107/74	3,000	2,600	4,000	4	7.72	116.2	594	950	1,700	
PHQ721F0055 K202VF0060 MT10	33.00	33/1	3,000	2,600	4,000	4	2.35	110.7	369	369	500	
PHQ721F0055 K202VF0060 MT20	33.00	33/1	3,000	2,600	4,000	4	2.95	112.8	624	950	1,700	
PHQ721F0055 K202VF0060 MT30	33.00	33/1	3,000	2,600	4,000	4	7.75	120.6	624	950	1,700	
PHQ721F0055 K202VF0067 MT10	36.76	2279/62	3,500	3,100	4,500	4	1.74	114.8	411	411	557	
PHQ721F0055 K202VF0067 MT20	36.76	2279/62	3,500	3,100	4,500	4	2.34	116.6	647	950	1,700	
PHQ721F0055 K202VF0067 MT30	36.76	2279/62	3,500	3,100	4,000	4	7.14	123.3	647	950	1,700	
PHQ721F0055 K202VF0071 MT20	39.15	23177/592	3,000	2,600	4,000	4	2.59	118.6	650	950	1,700	
PHQ721F0055 K202VF0071 MT30	39.15	23177/592	3,000	2,600	4,000	4	7.39	124.7	650	950	1,700	
PHQ721F0055 K202VF0084 MT10	46.18	1247/27	3,500	3,100	4,500	4	1.40	121.7	516	516	700	
PHQ721F0055 K202VF0084 MT20	46.18	1247/27	3,500	3,100	4,500	4	2.00	123.0	650	950	1,700	
PHQ721F0055 K202VF0084 MT30	46.18	1247/27	3,500	3,100	4,000	4	6.80	127.6	650	950	1,700	
PHQ721F0055 K202VF0092 MT10	50.55	25069/496	3,500	3,100	4,500	4	1.55	123.9	565	565	766	
PHQ721F0055 K202VF0092 MT20	50.55	25069/496	3,500	3,100	4,500	4	2.15	124.9	650	950	1,700	
PHQ721F0055 K202VF0092 MT30	50.55	25069/496	3,500	3,100	4,000	4	6.95	128.9	650	950	1,700	
PHQ721F0055 K202VF0100 MT10	55.40	2881/52	3,900	3,500	5,000	4	1.20	125.7	619	619	840	
PHQ721F0055 K202VF0100 MT20	55.40	2881/52	3,500	3,500	5,000	4	1.80	126.6	650	950	1,700	
PHQ721F0055 K202VF0100 MT30	55.40	2881/52	3,500	3,500	4,000	4	6.60	130.0	650	950	1,700	
PHQ721F0055 K202VF0115 MT10	63.50	13717/216	3,500	3,100	4,500	4	1.28	128.0	650	710	962	
PHQ721F0055 K202VF0115 MT20	63.50	13717/216	3,500	3,100	4,500	4	1.88	128.7	650	950	1,700	
PHQ721F0055 K202VF0115 MT30	63.50	13717/216	3,500	3,100	4,000	4	6.68	131.4	650	950	1,700	
PHQ721F0055 K202VF0125 MT10	69.88	559/8	3,900	3,500	5,000	4	1.02	129.3	650	781	1,059	
PHQ721F0055 K202VF0125 MT20	69.88	559/8	3,500	3,500	5,000	4	1.62	129.9	650	950	1,700	
PHQ721F0055 K202VF0125 MT30	69.88	559/8	3,500	3,500	4,000	4	6.42	132.1	650	950	1,700	
PHQ721F0055 K202VF0140 MT10	76.18	31691/416	3,900	3,500	5,000	4	1.11	130.3	650	851	1,155	
PHQ721F0055 K202VF0140 MT20	76.18	31691/416	3,500	3,500	5,000	4	1.71	130.8	650	950	1,700	
PHQ721F0055 K202VF0140 MT30	76.18	31691/416	3,500	3,500	4,000	4	6.51	132.7	650	950	1,700	
PHQ721F0055 K202VF0170 MT10	92.72	2967/32	4,000	3,900	5,500	4	0.87	132.0	650	950	1,405	
PHQ721F0055 K202VF0170 MT20	92.72	2967/32	3,500	3,500	5,000	4	1.47	132.4	650	950	1,700	
PHQ721F0055 K202VF0170 MT30	92.72	2967/32	3,500	3,500	4,000	4	6.27	133.7	650	950	1,700	
PHQ721F0055 K202VF0175 MT10	96.08	6149/64	3,900	3,500	5,000	4	0.97	132.3	650	950	1,456	
PHQ721F0055 K202VF0175 MT20	96.08	6149/64	3,500	3,500	5,000	4	1.57	132.6	650	950	1,700	
PHQ721F0055 K202VF0175 MT30	96.08	6149/64	3,500	3,500	4,000	4	6.37	133.8	650	950	1,700	
PHQ721F0055 K202VF0200 MT10	111.8	559/5	4,000	3,900	5,500	4	0.80	133.2	650	950	1,579	
PHQ721F0055 K202VF0200 MT20	111.8	559/5	3,500	3,500	5,000	4	1.40	133.5	650	950	1,700	
PHQ721F0055 K202VF0200 MT30	111.8	559/5	3,500	3,500	4,000	4	6.20	134.4	650	950	1,700	
PHQ721F0055 K202VF0230 MT10	127.5	32637/256	4,000	3,900	5,500	4	0.84	133.8	650	950	1,700	
PHQ721F0055 K202VF0230 MT20	127.5	32637/256	3,500	3,500	5,000	4	1.44	134.0	650	950	1,700	
PHQ721F0055 K202VF0230 MT30	127.5	32637/256	3,500	3,500	4,000	4	6.24	134.7	650	950	1,700	

PHQK

¹⁾ Inertia based on maximum input. For lower inertia using smaller diameter input, contact STOBER.

²⁾ Based on input speed: n₁ = 2000 RPM. For torque at higher input speeds (M_{2NX}) solve the formula, where n₁ = Actual Input Speed. $M_{2NX} = \frac{M_{2N}}{\sqrt[3]{\frac{n_1}{2000}}}$

³⁾ Maximum momentary torque for emergency stops or heavy shock load. Admissible stops per life of gearhead = 1,000 stops maximum.



"PHQK" Series – Right Angle ServoFit® Precision Planetary Gearhead Selection Data



Part Number	Reducer Ratio i		Input RPM Maximum			Backlash arcmins $\Delta\phi$	Input Inertia J ₁ kgcm ²	Torsional Stiffness per arcmin C ₂ Nm	Output Torque		
			Continuous		Cyclic				Nominal ¹⁾	Acceleration	Peak ²⁾
	Nom.	Exact	n _{1DBH}	n _{1DBV}	n _{1ZB}				M _{2N} ≤ 2000 RPM Nm	M _{2B} Nm	M _{2PEAK} Nm

PHQ721_K202 with Motor Mounting Plate Continued

PHQ721F0055 K202VF0250 MT10	138.2	1935/14	4,000	3,900	5,500	4	0.74	134.1	650	950	1,700
PHQ721F0055 K202VF0250 MT20	138.2	1935/14	3,500	3,500	5,000	4	1.34	134.3	650	950	1,700
PHQ721F0055 K202VF0250 MT30	138.2	1935/14	3,500	3,500	4,000	4	6.14	134.9	650	950	1,700
PHQ721F0055 K202VF0280 MT10	153.7	6149/40	4,000	3,900	5,500	4	0.78	134.4	650	950	1,700
PHQ721F0055 K202VF0280 MT20	153.7	6149/40	3,500	3,500	5,000	4	1.38	134.6	650	950	1,700
PHQ721F0055 K202VF0280 MT30	153.7	6149/40	3,500	3,500	4,000	4	6.18	135.0	650	950	1,700
PHQ721F0055 K202VF0340 MT10	184.9	1849/10	4,000	3,900	5,500	4	0.68	134.9	650	950	1,700
PHQ721F0055 K202VF0340 MT20	184.9	1849/10	3,500	3,500	5,000	4	1.28	134.9	650	950	1,700
PHQ721F0055 K202VF0350 MT10	190.0	21285/112	4,000	3,900	5,500	4	0.72	134.9	650	950	1,700
PHQ721F0055 K202VF0350 MT20	190.0	21285/112	3,500	3,500	5,000	4	1.32	135.0	650	950	1,700
PHQ721F0055 K202VF0350 MT30	190.0	21285/112	3,500	3,500	4,000	4	6.12	135.3	650	950	1,700
PHQ721F0055 K202VF0400 MT10	222.2	1333/6	4,000	3,900	5,500	4	0.66	135.2	610	732	1,133
PHQ721F0055 K202VF0460 MT10	254.2	20339/80	4,000	3,900	5,500	4	0.67	135.3	650	950	1,700
PHQ721F0055 K202VF0460 MT20	254.2	20339/80	3,500	3,500	5,000	4	1.27	135.4	650	950	1,700
PHQ721F0055 K202VF0500 MT10	277.7	6665/24	4,000	3,900	5,500	4	0.64	135.4	508	610	1,079
PHQ721F0055 K202VF0560 MT10	305.5	14663/48	4,000	3,900	5,500	4	0.65	135.5	650	950	1,558
PHQ721F0055 K202VF0690 MT10	381.8	73315/192	4,000	3,900	5,500	4	0.64	135.6	650	839	1,484

PHQ821_K402 with Motor Mounting Plate Continued Next Page

PHQ821F0055 K402VF0040 MT20	22.00	22/1	2,600	2,200	3,500	3.5	11.70	169.8	819	901	1,434
PHQ821F0055 K402VF0040 MT30	22.00	22/1	2,600	2,200	3,500	3.5	16.50	217.9	1,433	2,141	3,892
PHQ821F0055 K402VF0040 MT40	22.00	22/1	2,600	2,200	3,500	3.5	20.50	286.4	1,433	2,421	4,000
PHQ821F0055 K402VF0044 MT20	24.00	24/1	2,600	2,200	3,500	3.5	10.29	187.0	894	983	1,565
PHQ821F0055 K402VF0044 MT30	24.00	24/1	2,600	2,200	3,500	3.5	15.09	235.0	1,475	2,336	4,000
PHQ821F0055 K402VF0044 MT40	24.00	24/1	2,600	2,200	3,500	3.5	19.09	300.0	1,475	2,493	4,000
PHQ821F0055 K402VF0054 MT20	29.82	1849/62	2,600	2,200	3,500	3.5	7.68	230.1	1,111	1,222	1,944
PHQ821F0055 K402VF0054 MT30	29.82	1849/62	2,600	2,200	3,500	3.5	12.48	274.8	1,586	2,600	4,000
PHQ821F0055 K402VF0054 MT40	29.82	1849/62	2,600	2,200	3,500	3.5	16.48	328.9	1,586	2,600	4,000
PHQ821F0055 K402VF0060 MT20	33.00	33/1	2,600	2,200	3,500	3.5	8.37	249.5	1,229	1,352	2,151
PHQ821F0055 K402VF0060 MT30	33.00	33/1	2,600	2,200	3,500	3.5	13.17	291.5	1,641	2,600	4,000
PHQ821F0055 K402VF0060 MT40	33.00	33/1	2,600	2,200	3,500	3.5	17.17	339.9	1,641	2,600	4,000
PHQ821F0055 K402VF0067 MT20	36.95	2365/64	3,000	2,600	4,000	3.5	5.73	270.1	1,376	1,514	2,409
PHQ821F0055 K402VF0067 MT30	36.95	2365/64	3,000	2,600	4,000	3.5	10.53	308.4	1,700	2,600	4,000
PHQ821F0055 K402VF0067 MT40	36.95	2365/64	3,000	2,600	3,500	3.5	14.53	350.5	1,700	2,600	4,000
PHQ821F0055 K402VF0075 MT20	41.01	20339/496	2,600	2,200	3,500	3.5	6.44	287.6	1,527	1,680	2,673
PHQ821F0055 K402VF0075 MT30	41.01	20339/496	2,600	2,200	3,500	3.5	11.24	322.2	1,700	2,600	4,000
PHQ821F0055 K402VF0075 MT40	41.01	20339/496	2,600	2,200	3,500	3.5	15.24	358.8	1,700	2,600	4,000
PHQ821F0055 K402VF0084 MT20	46.07	645/14	3,000	2,600	4,000	3.5	4.39	305.4	1,700	1,888	3,003
PHQ821F0055 K402VF0084 MT30	46.07	645/14	3,000	2,600	4,000	3.5	9.19	335.8	1,700	2,600	4,000
PHQ821F0055 K402VF0084 MT40	46.07	645/14	3,000	2,600	3,500	3.5	13.19	366.6	1,700	2,600	4,000
PHQ821F0055 K402VF0092 MT20	50.81	26015/512	3,000	2,600	4,000	3.5	4.92	318.7	1,700	2,082	3,312
PHQ821F0055 K402VF0092 MT30	50.81	26015/512	3,000	2,600	4,000	3.5	9.72	345.6	1,700	2,600	4,000
PHQ821F0055 K402VF0092 MT40	50.81	26015/512	3,000	2,600	3,500	3.5	13.72	372.0	1,700	2,600	4,000

Index of Symbols: **MT** — Motor adapter with TriAdapt® coupling
L — Large Input
C — ServoCool

Max. Motor Shaft Diameter

Adapter	Shaft	Adapter	Shaft	Adapter	Shaft
MT10	19	MT30	38	MT50	60
MT20	24	MT40	48		

See Page 154 for Options and Part Number Configuration.



"PHQK" Series – Right Angle ServoFit® Precision Planetary Gearhead Selection Data



Part Number	Reducer Ratio i		Input RPM Maximum			Backlash arcmins Δφ	Input Inertia J ₁ kgcm ²	Torsional Stiffness per arcmin C ₂ Nm	Output Torque		
			Continuous		Cyclic				Nominal ¹⁾ M _{2N ≤ 2000 RPM} Nm	Acceleration M _{2B} Nm	Peak ²⁾ M _{2PEAK} Nm
	Nom.	Exact	n _{1DBH}	n _{1DBV}	n _{1ZB}				M _{2N}	M _{2B}	M _{2PEAK}
PHQ821_K402 with Motor Mounting Plate <i>Continued</i>											
PHQ821F0055 K402VF0100 MT20	55.54	1333/24	3,400	3,000	4,500	3.5	3.58	329.6	1,700	2,276	3,620
PHQ821F0055 K402VF0100 MT30	55.54	1333/24	3,400	3,000	4,000	3.5	8.38	353.4	1,700	2,600	4,000
PHQ821F0055 K402VF0100 MT40	55.54	1333/24	3,000	3,000	3,500	3.5	12.38	376.3	1,700	2,600	4,000
PHQ821F0055 K402VF0115 MT20	63.35	7095/112	3,000	2,600	4,000	3.5	3.87	343.5	1,700	2,596	4,000
PHQ821F0055 K402VF0115 MT30	63.35	7095/112	3,000	2,600	4,000	3.5	8.67	363.1	1,700	2,600	4,000
PHQ821F0055 K402VF0115 MT40	63.35	7095/112	3,000	2,600	3,500	3.5	12.67	381.4	1,700	2,600	4,000
PHQ821F0055 K402VF0125 MT20	69.62	1462/21	3,400	3,000	4,500	3.5	2.86	352.0	1,700	2,600	4,000
PHQ821F0055 K402VF0125 MT30	69.62	1462/21	3,400	3,000	4,000	3.5	7.66	368.9	1,700	2,600	4,000
PHQ821F0055 K402VF0125 MT40	69.62	1462/21	3,000	3,000	3,500	3.5	11.66	384.4	1,700	2,600	4,000
PHQ821F0055 K402VF0140 MT20	76.37	14663/192	3,400	3,000	4,500	3.5	3.22	359.2	1,700	2,600	4,000
PHQ821F0055 K402VF0140 MT30	76.37	14663/192	3,400	3,000	4,000	3.5	8.02	373.7	1,700	2,600	4,000
PHQ821F0055 K402VF0140 MT40	76.37	14663/192	3,000	3,000	3,500	3.5	12.02	386.9	1,700	2,600	4,000
PHQ821F0055 K402VF0170 MT20	93.16	559/6	3,500	3,300	5,000	3.5	2.22	371.6	1,700	2,600	4,000
PHQ821F0055 K402VF0170 MT30	93.16	559/6	3,500	3,300	4,000	3.5	7.02	381.8	1,700	2,600	4,000
PHQ821F0055 K402VF0170 MT40	93.16	559/6	3,000	3,000	3,500	3.5	11.02	391.0	1,700	2,600	4,000
PHQ821F0055 K402VF0175 MT20	95.73	8041/84	3,400	3,000	4,500	3.5	2.63	372.9	1,700	2,600	4,000
PHQ821F0055 K402VF0175 MT30	95.73	8041/84	3,400	3,000	4,000	3.5	7.43	382.7	1,700	2,600	4,000
PHQ821F0055 K402VF0175 MT40	95.73	8041/84	3,000	3,000	3,500	3.5	11.43	391.4	1,700	2,600	4,000
PHQ821F0055 K402VF0200 MT20	111.1	1333/12	3,500	3,300	5,000	3.5	1.96	379.5	1,700	2,600	4,000
PHQ821F0055 K402VF0200 MT30	111.1	1333/12	3,500	3,300	4,000	3.5	6.76	386.9	1,700	2,600	4,000
PHQ821F0055 K402VF0200 MT40	111.1	1333/12	3,000	3,000	3,500	3.5	10.76	393.5	1,700	2,600	4,000
PHQ821F0055 K402VF0230 MT20	128.1	6149/48	3,500	3,300	5,000	3.5	2.09	384.3	1,700	2,600	4,000
PHQ821F0055 K402VF0230 MT30	128.1	6149/48	3,500	3,300	4,000	3.5	6.89	390.0	1,700	2,600	4,000
PHQ821F0055 K402VF0230 MT40	128.1	6149/48	3,000	3,000	3,500	3.5	10.89	395.0	1,700	2,600	4,000
PHQ821F0055 K402VF0250 MT20	139.0	4171/30	3,500	3,300	5,000	3.5	1.72	386.5	1,700	2,600	4,000
PHQ821F0055 K402VF0250 MT30	139.0	4171/30	3,500	3,300	4,000	3.5	6.52	391.4	1,700	2,600	4,000
PHQ821F0055 K402VF0250 MT40	139.0	4171/30	3,000	3,000	3,500	3.5	10.52	395.7	1,700	2,600	4,000
PHQ821F0055 K402VF0280 MT20	152.7	14663/96	3,500	3,300	5,000	3.5	1.87	388.7	1,700	2,600	4,000
PHQ821F0055 K402VF0280 MT30	152.7	14663/96	3,500	3,300	4,000	3.5	6.67	392.8	1,700	2,600	4,000
PHQ821F0055 K402VF0280 MT40	152.7	14663/96	3,000	3,000	3,500	3.5	10.67	396.3	1,700	2,600	4,000
PHQ821F0055 K402VF0340 MT20	185.2	2408/13	3,500	3,300	5,000	3.5	1.52	392.1	1,700	2,464	4,000
PHQ821F0055 K402VF0340 MT30	185.2	2408/13	3,500	3,300	4,000	3.5	6.32	395.0	1,700	2,464	4,000
PHQ821F0055 K402VF0350 MT20	191.2	45881/240	3,500	3,300	5,000	3.5	1.66	392.6	1,700	2,600	4,000
PHQ821F0055 K402VF0350 MT30	191.2	45881/240	3,500	3,300	4,000	3.5	6.46	395.2	1,700	2,600	4,000
PHQ821F0055 K402VF0350 MT40	191.2	45881/240	3,000	3,000	3,500	3.5	10.46	397.5	1,700	2,600	4,000
PHQ821F0055 K402VF0410 MT20	222.8	2451/11	3,500	3,300	5,000	3.5	1.43	394.4	1,626	1,952	3,529
PHQ821F0055 K402VF0410 MT30	222.8	2451/11	3,500	3,300	4,000	3.5	6.23	396.4	1,626	1,952	3,529
PHQ821F0055 K402VF0460 MT20	254.7	3311/13	3,500	3,300	5,000	3.5	1.48	395.6	1,700	2,600	4,000
PHQ821F0055 K402VF0460 MT30	254.7	3311/13	3,500	3,300	4,000	3.5	6.28	397.1	1,700	2,600	4,000
PHQ821F0055 K402VF0500 MT20	277.3	5547/20	3,500	3,300	5,000	3.5	1.35	396.2	1,423	1,708	2,435
PHQ821F0055 K402VF0560 MT20	306.4	2451/8	3,500	3,300	5,000	3.5	1.41	396.8	1,700	2,600	4,000
PHQ821F0055 K402VF0560 MT30	306.4	2451/8	3,500	3,300	4,000	3.5	6.21	397.9	1,700	2,600	4,000
PHQ821F0055 K402VF0690 MT20	381.4	61017/160	3,500	3,300	5,000	3.5	1.34	397.8	1,700	2,348	3,349

¹⁾ Inertia based on maximum input. For lower inertia using smaller diameter input, contact STOBER.

²⁾ Based on input speed: n₁ = 2000 RPM. For torque at higher input speeds (M_{2NX}) solve the formula, where n₁ = Actual Input Speed. $M_{2NX} = \frac{M_{2N}}{\sqrt[3]{\frac{n_1}{2000}}}$

³⁾ Maximum momentary torque for emergency stops or heavy shock load. Admissible stops per life of gearhead = 1,000 stops maximum.



"PHQK" Series – Right Angle ServoFit® Precision Planetary Gearhead Selection Data



Part Number	Reducer Ratio i		Input RPM Maximum			Backlash arcmins $\Delta\phi$	Input Inertia J ₁ kgcm ²	Torsional Stiffness per arcmin C ₂ Nm	Output Torque		
			Continuous		Cyclic				Nominal ¹⁾ M _{2N} ≤ 2000 RPM Nm	Acceleration M _{2B} Nm	Peak ²⁾ M _{2PEAK} Nm
	Nom.	Exact	n _{1DBH}	n _{1DBV}	n _{1ZB}						
PHQ931F0060 K513VF0073 MT30	44.08	1102/25	1,900	1,800	3,000	4	22.69	550.5	3,551	4,228	7,687
PHQ931F0060 K513VF0073 MT40	44.08	1102/25	1,900	1,800	3,000	4	26.69	648.1	3,551	5,760	8,780
PHQ931F0060 K513VF0081 MT30	48.80	17081/350	1,900	1,800	3,000	4	20.81	581.1	3,674	4,681	8,510
PHQ931F0060 K513VF0081 MT40	48.80	17081/350	1,900	1,800	3,000	4	24.81	667.7	3,674	5,760	9,720
PHQ931F0060 K513VF0092 MT30	55.01	8526/155	1,900	1,800	3,000	4	17.94	613.3	3,800	5,276	9,592
PHQ931F0060 K513VF0092 MT40	55.01	8526/155	1,900	1,800	3,000	4	21.94	687.3	3,800	5,760	10,956
PHQ931F0060 K513VF0100 MT30	60.90	609/10	1,900	1,800	3,000	4	16.74	637.3	3,800	5,760	10,619
PHQ931F0060 K513VF0100 MT40	60.90	609/10	1,900	1,800	3,000	4	20.74	701.4	3,800	5,760	11,250
PHQ931F0060 K513VF0115 MT30	69.41	10759/155	2,300	2,200	3,600	4	14.30	663.8	3,800	5,760	11,250
PHQ931F0060 K513VF0115 MT40	69.41	10759/155	2,300	2,200	3,500	4	18.30	716.3	3,800	5,760	11,250
PHQ931F0060 K513VF0130 MT30	76.85	1537/20	2,300	2,200	3,600	4	13.55	681.3	3,800	5,760	11,250
PHQ931F0060 K513VF0130 MT40	76.85	1537/20	2,300	2,200	3,500	4	17.55	725.8	3,800	5,760	11,250
PHQ931F0060 K513VF0145 MT20	87.22	11774/135	2,300	2,200	3,600	4	7.10	661.2	3,202	3,522	5,603
PHQ931F0060 K513VF0145 MT30	87.22	11774/135	2,300	2,200	3,600	4	11.90	699.5	3,800	5,760	11,250
PHQ931F0060 K513VF0145 MT40	87.22	11774/135	2,300	2,200	3,500	4	15.90	735.5	3,800	5,760	11,250
PHQ931F0060 K513VF0160 MT20	96.56	26071/270	2,300	2,200	3,600	4	6.62	679.1	3,545	3,899	6,203
PHQ931F0060 K513VF0160 MT30	96.56	26071/270	2,300	2,200	3,600	4	11.42	711.7	3,800	5,760	11,250
PHQ931F0060 K513VF0160 MT40	96.56	26071/270	2,300	2,200	3,500	4	15.42	741.8	3,800	5,760	11,250
PHQ931F0060 K513VF0175 MT20	104.9	6293/60	2,800	2,500	4,000	4	5.69	691.7	3,800	4,235	6,738
PHQ931F0060 K513VF0175 MT30	104.9	6293/60	2,800	2,500	4,000	4	10.49	720.2	3,800	5,760	11,250
PHQ931F0060 K513VF0175 MT40	104.9	6293/60	2,800	2,500	3,500	4	14.49	746.1	3,800	5,760	11,250
PHQ931F0060 K513VF0195 MT20	116.1	27869/240	2,800	2,500	4,000	4	5.36	705.0	3,800	4,689	7,460
PHQ931F0060 K513VF0195 MT30	116.1	27869/240	2,800	2,500	4,000	4	10.16	729.0	3,800	5,760	11,250
PHQ931F0060 K513VF0195 MT40	116.1	27869/240	2,800	2,500	3,500	4	14.16	750.6	3,800	5,760	11,250
PHQ931F0060 K513VF0220 MT20	132.0	2639/20	2,800	2,500	4,000	4	4.39	718.9	3,800	5,328	8,477
PHQ931F0060 K513VF0220 MT30	132.0	2639/20	2,800	2,500	4,000	4	9.19	738.1	3,800	5,760	11,250
PHQ931F0060 K513VF0220 MT40	132.0	2639/20	2,800	2,500	3,500	4	13.19	755.1	3,800	5,760	11,250
PHQ931F0060 K513VF0240 MT20	146.1	11687/80	2,800	2,500	4,000	4	4.18	728.0	3,800	5,760	9,385
PHQ931F0060 K513VF0240 MT30	146.1	11687/80	2,800	2,500	4,000	4	8.98	744.0	3,800	5,760	11,250
PHQ931F0060 K513VF0240 MT40	146.1	11687/80	2,800	2,500	3,500	4	12.98	758.0	3,800	5,760	11,250
PHQ931F0060 K513VF0290 MT20	175.1	14007/80	3,400	3,000	4,500	4	3.26	740.6	3,800	5,760	10,351
PHQ931F0060 K513VF0290 MT30	175.1	14007/80	3,400	3,000	4,000	4	8.06	752.0	3,800	5,760	11,250
PHQ931F0060 K513VF0290 MT40	175.1	14007/80	3,000	3,000	3,500	4	12.06	762.0	3,800	5,760	11,250
PHQ931F0060 K513VF0320 MT20	193.8	62031/320	3,400	3,000	4,500	4	3.14	746.0	3,800	5,760	11,250
PHQ931F0060 K513VF0320 MT30	193.8	62031/320	3,400	3,000	4,000	4	7.94	755.5	3,800	5,760	11,250
PHQ931F0060 K513VF0320 MT40	193.8	62031/320	3,000	3,000	3,500	4	11.94	763.6	3,800	5,760	11,250
PHQ931F0060 K513VF0350 MT20	208.8	1044/5	3,400	3,000	4,500	4	2.76	749.4	3,800	5,760	11,132
PHQ931F0060 K513VF0350 MT30	208.8	1044/5	3,400	3,000	4,000	4	7.56	757.6	3,800	5,760	11,132
PHQ931F0060 K513VF0350 MT40	208.8	1044/5	3,000	3,000	3,500	4	11.56	764.7	3,800	5,760	11,132
PHQ931F0060 K513VF0390 MT20	231.2	8091/35	3,400	3,000	4,500	4	2.67	753.3	3,800	5,760	11,250
PHQ931F0060 K513VF0390 MT30	231.2	8091/35	3,400	3,000	4,000	4	7.47	760.1	3,800	5,760	11,250
PHQ931F0060 K513VF0390 MT40	231.2	8091/35	3,000	3,000	3,500	4	11.47	765.9	3,800	5,760	11,250
PHQ931F0060 K513VF0440 MT20	261.0	261/1	3,400	3,000	4,500	4	2.27	757.1	3,800	5,760	11,250
PHQ931F0060 K513VF0440 MT30	261.0	261/1	3,400	3,000	4,000	4	7.07	762.4	3,800	5,760	11,250
PHQ931F0060 K513VF0440 MT40	261.0	261/1	3,000	3,000	3,500	4	11.07	767.0	3,800	5,760	11,250

PHQK

PHQ931_K513 with Motor Mounting Plate Continued Next Page

Index of Symbols: **MT** — Motor adapter with TriAdapt® coupling
L — Large Input
C — ServoCool

Max. Motor Shaft Diameter

Adapter	Shaft	Adapter	Shaft	Adapter	Shaft
MT10	19	MT30	38	MT50	60
MT20	24	MT40	48		

See Page 154 for Options and Part Number Configuration.



"PHQK" Series – Right Angle ServoFit® Precision Planetary Gearhead Selection Data



Part Number	Reducer Ratio i		Input RPM Maximum			Backlash arcmins $\Delta\phi$	Input Inertia J ₁ kgcm ²	Torsional Stiffness per arcmin C ₂ Nm	Output Torque		
			Continuous		Cyclic				Nominal ¹⁾	Acceleration	Peak ²⁾
	Nom.	Exact	n _{1DBH}	n _{1DBV}	n _{1ZB}				M _{2N ≤ 2000 RPM} Nm	M _{2B} Nm	M _{2PEAK} Nm

PHQ931_K513 with Motor Mounting Plate Continued

PHQ931F0060 K513VF0480 MT20	289.0	8091/28	3,400	3,000	4,500	4	2.22	759.6	3,800	5,760	11,250
PHQ931F0060 K513VF0480 MT30	289.0	8091/28	3,400	3,000	4,000	4	7.02	764.0	3,800	5,760	11,250
PHQ931F0060 K513VF0480 MT40	289.0	8091/28	3,000	3,000	3,500	4	11.02	767.8	3,800	5,760	11,250
PHQ931F0060 K513VF0580 MT20	349.8	22736/65	3,400	3,000	4,500	4	1.85	763.3	3,800	5,760	11,250
PHQ931F0060 K513VF0580 MT30	349.8	22736/65	3,400	3,000	4,000	4	6.65	766.3	3,800	5,760	11,250
PHQ931F0060 K513VF0580 MT40	349.8	22736/65	3,000	3,000	3,500	4	10.65	768.8	3,800	5,760	11,250
PHQ931F0060 K513VF0650 MT20	387.3	25172/65	3,400	3,000	4,500	4	1.82	764.7	3,800	5,760	11,250
PHQ931F0060 K513VF0650 MT30	387.3	25172/65	3,400	3,000	4,000	4	6.62	767.2	3,800	5,760	11,250
PHQ931F0060 K513VF0650 MT40	387.3	25172/65	3,000	3,000	3,500	4	10.62	769.3	3,800	5,760	11,250
PHQ931F0060 K513VF0700 MT20	420.5	841/2	3,400	3,000	4,500	4	1.67	765.7	3,800	5,671	7,899
PHQ931F0060 K513VF0700 MT30	420.5	841/2	3,400	3,000	4,000	4	6.47	767.8	3,800	5,671	7,899
PHQ931F0060 K513VF0780 MT20	465.6	26071/56	3,400	3,000	4,500	4	1.65	766.7	3,800	5,760	8,745
PHQ931F0060 K513VF0780 MT30	465.6	26071/56	3,400	3,000	4,000	4	6.45	768.4	3,800	5,760	8,745
PHQ931F0060 K513VF0870 MT20	523.7	26187/50	3,400	3,000	4,500	4	1.52	767.6	3,800	4,764	8,069
PHQ931F0060 K513VF0870 MT30	523.7	26187/50	3,400	3,000	4,000	4	6.32	769.0	3,800	4,764	8,069
PHQ931F0060 K513VF0970 MT20	579.9	115971/200	3,400	3,000	4,500	4	1.50	768.3	3,800	5,276	8,934
PHQ931F0060 K513VF0970 MT30	579.9	115971/200	3,400	3,000	4,000	4	6.30	769.4	3,800	5,276	8,934

PHQ1031_K713 with Motor Mounting Plate Continued Next Page

PHQ1031F0060 K713VF0076 MT30	45.38	59535/1312	1,700	1,600	2,700	4	66.38	883.9	3,956	4,352	7,913
PHQ1031F0060 K713VF0076 MT40	45.38	59535/1312	1,700	1,600	2,700	4	70.38	1,145.3	6,500	6,663	9,038
PHQ1031F0060 K713VF0076 MT50	45.38	59535/1312	1,700	1,600	2,700	4	80.38	1,398.1	6,500	10,000	16,946
PHQ1031F0060 K713VF0084 MT30	50.24	263655/5248	1,700	1,600	2,700	4	62.01	960.6	4,380	4,818	8,760
PHQ1031F0060 K713VF0084 MT40	50.24	263655/5248	1,700	1,600	2,700	4	66.01	1,204.3	6,500	7,377	10,006
PHQ1031F0060 K713VF0084 MT50	50.24	263655/5248	1,700	1,600	2,700	4	76.01	1,425.4	6,500	10,000	18,761
PHQ1031F0060 K713VF0092 MT30	55.13	441/8	1,700	1,600	2,700	4	51.18	1,027.6	4,806	5,287	9,613
PHQ1031F0060 K713VF0092 MT40	55.13	441/8	1,700	1,600	2,700	4	55.18	1,252.8	6,500	8,095	10,980
PHQ1031F0060 K713VF0092 MT50	55.13	441/8	1,700	1,600	2,700	4	65.18	1,446.7	6,500	10,000	20,000
PHQ1031F0060 K713VF0100 MT30	61.03	1953/32	1,700	1,600	2,700	4	48.21	1,096.6	5,321	5,853	10,642
PHQ1031F0060 K713VF0100 MT40	61.03	1953/32	1,700	1,600	2,700	4	52.21	1,300.0	6,500	8,962	12,156
PHQ1031F0060 K713VF0100 MT50	61.03	1953/32	1,700	1,600	2,700	4	62.21	1,466.4	6,500	10,000	20,000
PHQ1031F0060 K713VF0120 MT30	70.69	70119/992	2,000	1,900	3,000	4	37.24	1,186.3	6,163	6,779	12,326
PHQ1031F0060 K713VF0120 MT40	70.69	70119/992	2,000	1,900	3,000	4	41.24	1,357.7	6,500	10,000	14,078
PHQ1031F0060 K713VF0120 MT50	70.69	70119/992	2,000	1,900	3,000	4	51.24	1,489.3	6,500	10,000	20,000
PHQ1031F0060 K713VF0130 MT30	78.26	10017/128	2,000	1,900	3,000	4	35.44	1,241.2	6,500	7,505	13,646
PHQ1031F0060 K713VF0130 MT40	78.26	10017/128	2,000	1,900	3,000	4	39.44	1,391.0	6,500	10,000	15,586
PHQ1031F0060 K713VF0130 MT50	78.26	10017/128	2,000	1,900	3,000	4	49.44	1,501.9	6,500	10,000	20,000
PHQ1031F0060 K713VF0150 MT30	88.81	1421/16	2,000	1,900	3,000	4	28.54	1,300.7	6,500	8,518	15,487
PHQ1031F0060 K713VF0150 MT40	88.81	1421/16	2,000	1,900	3,000	4	32.54	1,425.7	6,500	10,000	17,643
PHQ1031F0060 K713VF0150 MT50	88.81	1421/16	2,000	1,900	3,000	4	42.54	1,514.7	6,500	10,000	20,000
PHQ1031F0060 K713VF0165 MT30	98.33	6293/64	2,000	1,900	3,000	4	27.40	1,341.9	6,500	9,430	17,146
PHQ1031F0060 K713VF0165 MT40	98.33	6293/64	2,000	1,900	3,000	4	31.40	1,448.7	6,500	10,000	19,533
PHQ1031F0060 K713VF0165 MT50	98.33	6293/64	2,000	1,900	3,000	4	41.40	1,522.9	6,500	10,000	20,000
PHQ1031F0060 K713VF0185 MT30	109.7	80703/736	2,400	2,200	3,400	4	22.96	1,379.7	6,500	10,000	19,120
PHQ1031F0060 K713VF0185 MT40	109.7	80703/736	2,400	2,200	3,400	4	26.96	1,469.4	6,500	10,000	20,000
PHQ1031F0060 K713VF0185 MT50	109.7	80703/736	2,400	2,200	3,000	4	36.96	1,530.2	6,500	10,000	20,000

¹⁾ Inertia based on maximum input. For lower inertia using smaller diameter input, contact STOBER.

²⁾ Based on input speed: n₁ = 2000 RPM. For torque at higher input speeds (M_{2NX}) solve the formula, where n₁ = Actual Input Speed. $M_{2NX} = \frac{M_{2N}}{\sqrt[3]{\frac{n_1}{2000}}}$

³⁾ Maximum momentary torque for emergency stops or heavy shock load. Admissible stops per life of gearhead = 1,000 stops maximum.



"PHQK" Series – Right Angle ServoFit® Precision Planetary Gearhead Selection Data



Part Number	Reducer Ratio i		Input RPM Maximum			Backlash arcmins $\Delta\phi$	Input Inertia J ₁ kgcm ²	Torsional Stiffness per arcmin C ₂ Nm	Output Torque		
			Continuous		Cyclic				Nominal ¹⁾ M _{2N} ≤ 2000 RPM Nm	Acceleration M _{2B} Nm	Peak ²⁾ M _{2PEAK} Nm
	Nom.	Exact	n _{1DBH}	n _{1DBV}	n _{1ZB}						
PHQ1031_K713 with Motor Mounting Plate Continued											
PHQ1031F0060 K713VF0200 MT30	121.4	357399/2944	2,400	2,200	3,400	4	22.21	1,409.8	6,500	10,000	20,000
PHQ1031F0060 K713VF0200 MT40	121.4	357399/2944	2,400	2,200	3,400	4	26.21	1,485.4	6,500	10,000	20,000
PHQ1031F0060 K713VF0200 MT50	121.4	357399/2944	2,400	2,200	3,000	4	36.21	1,535.7	6,500	10,000	20,000
PHQ1031F0060 K713VF0230 MT30	136.4	43659/320	2,400	2,200	3,400	4	18.22	1,438.8	6,500	10,000	20,000
PHQ1031F0060 K713VF0230 MT40	136.4	43659/320	2,400	2,200	3,400	4	22.22	1,500.4	6,500	10,000	20,000
PHQ1031F0060 K713VF0230 MT50	136.4	43659/320	2,400	2,200	3,000	4	32.22	1,540.8	6,500	10,000	20,000
PHQ1031F0060 K713VF0250 MT30	151.1	193347/1280	2,400	2,200	3,400	4	17.74	1,459.8	6,500	10,000	20,000
PHQ1031F0060 K713VF0250 MT40	151.1	193347/1280	2,400	2,200	3,400	4	21.74	1,511.2	6,500	10,000	20,000
PHQ1031F0060 K713VF0250 MT50	151.1	193347/1280	2,400	2,200	3,000	4	31.74	1,544.4	6,500	10,000	20,000
PHQ1031F0060 K713VF0290 MT30	175.7	22491/128	2,900	2,600	3,800	4	14.15	1,484.8	6,500	10,000	20,000
PHQ1031F0060 K713VF0290 MT40	175.7	22491/128	2,900	2,600	3,500	4	18.15	1,523.8	6,500	10,000	20,000
PHQ1031F0060 K713VF0290 MT50	175.7	22491/128	2,500	2,500	3,000	4	28.15	1,548.6	6,500	10,000	20,000
PHQ1031F0060 K713VF0320 MT30	194.5	99603/512	2,900	2,600	3,800	4	13.86	1,498.2	6,500	10,000	20,000
PHQ1031F0060 K713VF0320 MT40	194.5	99603/512	2,900	2,600	3,500	4	17.86	1,530.4	6,500	10,000	20,000
PHQ1031F0060 K713VF0320 MT50	194.5	99603/512	2,500	2,500	3,000	4	27.86	1,550.8	6,500	10,000	20,000
PHQ1031F0060 K713VF0350 MT30	212.6	1701/8	2,900	2,600	3,800	4	12.01	1,508.1	6,500	10,000	20,000
PHQ1031F0060 K713VF0350 MT40	212.6	1701/8	2,900	2,600	3,500	4	16.01	1,535.3	6,500	10,000	20,000
PHQ1031F0060 K713VF0350 MT50	212.6	1701/8	2,500	2,500	3,000	4	26.01	1,552.4	6,500	10,000	20,000
PHQ1031F0060 K713VF0390 MT30	235.4	7533/32	2,900	2,600	3,800	4	11.81	1,517.5	6,500	10,000	20,000
PHQ1031F0060 K713VF0390 MT40	235.4	7533/32	2,900	2,600	3,500	4	15.81	1,539.9	6,500	10,000	20,000
PHQ1031F0060 K713VF0390 MT50	235.4	7533/32	2,500	2,500	3,000	4	25.81	1,553.9	6,500	10,000	20,000
PHQ1031F0060 K713VF0450 MT30	270.3	112455/416	2,900	2,600	3,800	4	10.06	1,527.7	6,500	10,000	20,000
PHQ1031F0060 K713VF0450 MT40	270.3	112455/416	2,900	2,600	3,500	4	14.06	1,544.9	6,500	10,000	20,000
PHQ1031F0060 K713VF0450 MT50	270.3	112455/416	2,500	2,500	3,000	4	24.06	1,555.5	6,500	10,000	20,000
PHQ1031F0060 K713VF0500 MT30	299.3	498015/1664	2,900	2,600	3,800	4	9.94	1,533.6	6,500	10,000	20,000
PHQ1031F0060 K713VF0500 MT40	299.3	498015/1664	2,900	2,600	3,500	4	13.94	1,547.7	6,500	10,000	20,000
PHQ1031F0060 K713VF0500 MT50	299.3	498015/1664	2,500	2,500	3,000	4	23.94	1,556.5	6,500	10,000	20,000
PHQ1031F0060 K713VF0590 MT30	351.4	22491/64	2,900	2,600	3,800	4	8.58	1,541.0	6,500	10,000	20,000
PHQ1031F0060 K713VF0590 MT40	351.4	22491/64	2,900	2,600	3,500	4	12.58	1,551.3	6,500	10,000	20,000
PHQ1031F0060 K713VF0590 MT50	351.4	22491/64	2,500	2,500	3,000	4	22.58	1,557.6	6,500	10,000	20,000
PHQ1031F0060 K713VF0650 MT30	389.1	99603/256	2,900	2,600	3,800	4	8.51	1,544.6	6,500	10,000	20,000
PHQ1031F0060 K713VF0650 MT40	389.1	99603/256	2,900	2,600	3,500	4	12.51	1,553.0	6,500	10,000	20,000
PHQ1031F0060 K713VF0650 MT50	389.1	99603/256	2,500	2,500	3,000	4	22.51	1,558.2	6,500	10,000	20,000
PHQ1031F0060 K713VF0710 MT30	427.2	13671/32	2,900	2,600	3,800	4	7.83	1,547.3	6,500	10,000	17,676
PHQ1031F0060 K713VF0710 MT40	427.2	13671/32	2,900	2,600	3,500	4	11.83	1,554.3	6,500	10,000	17,676
PHQ1031F0060 K713VF0790 MT30	473.0	60543/128	2,900	2,600	3,800	4	7.78	1,549.7	6,500	10,000	19,570
PHQ1031F0060 K713VF0790 MT40	473.0	60543/128	2,900	2,600	3,500	4	11.78	1,555.4	6,500	10,000	19,570
PHQ1031F0060 K713VF0890 MT30	534.0	68355/128	2,900	2,600	3,800	4	7.23	1,552.1	6,500	10,000	18,454
PHQ1031F0060 K713VF0890 MT40	534.0	68355/128	2,900	2,600	3,500	4	11.23	1,556.6	6,500	10,000	18,454
PHQ1031F0060 K713VF0990 MT30	591.2	302715/512	2,900	2,600	3,800	4	7.20	1,553.6	6,500	10,000	20,000
PHQ1031F0060 K713VF0990 MT40	591.2	302715/512	2,900	2,600	3,500	4	11.20	1,557.3	6,500	10,000	20,000

PHQK

Index of Symbols: MT — Motor adapter with TriAdapt® coupling
L — Large Input
C — ServoCool

Max. Motor Shaft Diameter					
Adapter	Shaft	Adapter	Shaft	Adapter	Shaft
MT10	19	MT30	38	MT50	60
MT20	24	MT40	48		

See Page 154 for Options and Part Number Configuration.



"PHQK" Series – Right Angle ServoFit® Precision Planetary Gearhead Selection Data



Part Number	Reducer Ratio i		Input RPM Maximum			Backlash arcmins Δφ	Input Inertia J ₁ kgcm ²	Torsional Stiffness per arcmin C ₂ Nm	Output Torque		
			Continuous		Cyclic				Nominal ¹⁾ M _{2N ≤ 2000 RPM} Nm	Acceleration M _{2B} Nm	Peak ²⁾ M _{2PEAK} Nm
	Nom.	Exact	n _{1DBH}	n _{1DBV}	n _{1ZB}				M _{2N}	M _{2B}	M _{2PEAK}
PHQ1131_K813 with Motor Mounting Plate Continued Next Page											
PHQ1131F0060 K813VF0074 MT30	44.67	3127/70	1,600	1,500	2,600	4	151.97	1,126.9	3,895	4,284	7,789
PHQ1131F0060 K813VF0074 MT40	44.67	3127/70	1,600	1,500	2,600	4	155.97	1,610.3	6,559	6,559	8,897
PHQ1131F0060 K813VF0074 MT50	44.67	3127/70	1,600	1,500	2,600	4	165.97	2,183.1	12,299	12,299	16,681
PHQ1131F0060 K813VF0082 MT30	49.46	96937/1960	1,600	1,500	2,600	4	137.89	1,259.2	4,312	4,743	8,624
PHQ1131F0060 K813VF0082 MT40	49.46	96937/1960	1,600	1,500	2,600	4	141.89	1,733.7	7,262	7,262	9,850
PHQ1131F0060 K813VF0082 MT50	49.46	96937/1960	1,600	1,500	2,600	4	151.89	2,252.8	13,000	13,617	18,469
PHQ1131F0060 K813VF0093 MT30	55.70	11977/215	1,600	1,500	2,600	4	109.61	1,415.0	4,857	5,342	9,713
PHQ1131F0060 K813VF0093 MT40	55.70	11977/215	1,600	1,500	2,600	4	113.61	1,867.8	8,180	8,180	11,094
PHQ1131F0060 K813VF0093 MT50	55.70	11977/215	1,600	1,500	2,600	4	123.61	2,322.2	13,000	15,337	20,802
PHQ1131F0060 K813VF0105 MT30	61.67	53041/860	1,600	1,500	2,600	4	100.54	1,546.2	5,377	5,915	10,754
PHQ1131F0060 K813VF0105 MT40	61.67	53041/860	1,600	1,500	2,600	4	104.54	1,972.4	9,056	9,056	12,283
PHQ1131F0060 K813VF0105 MT50	61.67	53041/860	1,600	1,500	2,600	4	114.54	2,372.4	13,000	16,981	23,031
PHQ1131F0060 K813VF0120 MT30	71.44	13216/185	1,900	1,800	2,900	4	76.98	1,726.7	6,228	6,851	12,457
PHQ1131F0060 K813VF0120 MT40	71.44	13216/185	1,900	1,800	2,900	4	80.98	2,105.4	10,490	10,490	14,228
PHQ1131F0060 K813VF0120 MT50	71.44	13216/185	1,900	1,800	2,900	4	90.98	2,431.6	13,000	19,668	26,677
PHQ1131F0060 K813VF0130 MT30	79.09	14632/185	1,900	1,800	2,900	4	71.47	1,842.7	6,896	7,585	13,792
PHQ1131F0060 K813VF0130 MT40	79.09	14632/185	1,900	1,800	2,900	4	75.47	2,184.9	11,614	11,614	15,752
PHQ1131F0060 K813VF0130 MT50	79.09	14632/185	1,900	1,800	2,900	4	85.47	2,464.8	13,000	21,776	29,536
PHQ1131F0060 K813VF0150 MT30	89.05	28497/320	1,900	1,800	2,900	4	56.85	1,966.3	7,764	8,541	15,528
PHQ1131F0060 K813VF0150 MT40	89.05	28497/320	1,900	1,800	2,900	4	60.85	2,264.8	13,000	13,077	17,736
PHQ1131F0060 K813VF0150 MT50	89.05	28497/320	1,900	1,800	2,900	4	70.85	2,496.6	13,000	22,000	33,255
PHQ1131F0060 K813VF0165 MT30	98.59	126201/1280	1,900	1,800	2,900	4	53.30	2,061.4	8,596	9,456	17,192
PHQ1131F0060 K813VF0165 MT40	98.59	126201/1280	1,900	1,800	2,900	4	57.30	2,323.3	13,000	14,477	19,636
PHQ1131F0060 K813VF0165 MT50	98.59	126201/1280	1,900	1,800	2,900	4	67.30	2,519.0	13,000	22,000	36,818
PHQ1131F0060 K813VF0175 MT30	104.0	30149/290	2,300	2,100	3,300	4	46.74	2,106.8	9,064	9,971	18,128
PHQ1131F0060 K813VF0175 MT40	104.0	30149/290	2,300	2,100	3,300	4	50.74	2,350.3	13,000	15,266	20,706
PHQ1131F0060 K813VF0175 MT50	104.0	30149/290	2,300	2,100	3,000	4	60.74	2,529.1	13,000	22,000	38,823
PHQ1131F0060 K813VF0190 MT30	115.1	133517/1160	2,300	2,100	3,300	4	44.14	2,186.0	10,035	11,039	20,070
PHQ1131F0060 K813VF0190 MT40	115.1	133517/1160	2,300	2,100	3,300	4	48.14	2,396.3	13,000	16,901	22,924
PHQ1131F0060 K813VF0190 MT50	115.1	133517/1160	2,300	2,100	3,000	4	58.14	2,546.0	13,000	22,000	40,000
PHQ1131F0060 K813VF0230 MT30	138.3	31801/230	2,300	2,100	3,300	4	32.82	2,303.9	12,055	13,260	24,110
PHQ1131F0060 K813VF0230 MT40	138.3	31801/230	2,300	2,100	3,300	4	36.82	2,461.7	13,000	18,054	24,487
PHQ1131F0060 K813VF0230 MT50	138.3	31801/230	2,300	2,100	3,000	4	46.82	2,569.2	13,000	22,000	40,000
PHQ1131F0060 K813VF0260 MT30	153.1	140833/920	2,300	2,100	3,300	4	31.35	2,356.8	13,000	14,681	26,693
PHQ1131F0060 K813VF0260 MT40	153.1	140833/920	2,300	2,100	3,300	4	35.35	2,489.9	13,000	19,988	27,110
PHQ1131F0060 K813VF0260 MT50	153.1	140833/920	2,300	2,100	3,000	4	45.35	2,579.0	13,000	22,000	40,000
PHQ1131F0060 K813VF0290 MT30	175.5	7021/40	2,800	2,500	3,600	4	24.32	2,415.5	13,000	16,834	29,295
PHQ1131F0060 K813VF0290 MT40	175.5	7021/40	2,800	2,500	3,500	4	28.32	2,520.6	13,000	21,599	29,295
PHQ1131F0060 K813VF0290 MT50	175.5	7021/40	2,500	2,500	3,000	4	38.32	2,589.5	13,000	22,000	40,000
PHQ1131F0060 K813VF0320 MT30	194.3	31093/160	2,800	2,500	3,600	4	23.40	2,451.3	13,000	18,638	32,435
PHQ1131F0060 K813VF0320 MT40	194.3	31093/160	2,800	2,500	3,500	4	27.40	2,538.9	13,000	22,000	32,435
PHQ1131F0060 K813VF0320 MT50	194.3	31093/160	2,500	2,500	3,000	4	37.40	2,595.6	13,000	22,000	40,000
PHQ1131F0060 K813VF0360 MT30	216.8	8673/40	2,800	2,500	3,600	4	19.03	2,483.3	13,000	20,795	30,365
PHQ1131F0060 K813VF0360 MT40	216.8	8673/40	2,800	2,500	3,500	4	23.03	2,555.1	13,000	22,000	30,365
PHQ1131F0060 K813VF0360 MT50	216.8	8673/40	2,500	2,500	3,000	4	33.03	2,601.0	13,000	22,000	40,000

¹⁾ Inertia based on maximum input. For lower inertia using smaller diameter input, contact STOBER.

²⁾ Based on input speed: n₁ = 2000 RPM. For torque at higher input speeds (M_{2NX}) solve the formula, where n₁ = Actual Input Speed. $M_{2NX} = \frac{M_{2N}}{\sqrt[3]{\frac{n_1}{2000}}}$

³⁾ Maximum momentary torque for emergency stops or heavy shock load. Admissible stops per life of gearhead = 1,000 stops maximum.



"PHQK" Series – Right Angle ServoFit® Precision Planetary Gearhead Selection Data



Part Number	Reducer Ratio i		Input RPM Maximum			Backlash arcmins $\Delta\phi$	Input Inertia J ₁ kgcm ²	Torsional Stiffness per arcmin C ₂ Nm	Output Torque		
			Continuous		Cyclic				Nominal ¹⁾	Acceleration	Peak ²⁾
	Nom.	Exact	n _{1DBH}	n _{1DBV}	n _{1ZB}				M _{2N ≤ 2000 RPM} Nm	M _{2B} Nm	M _{2PEAK} Nm
PHQ1131_K813 with Motor Mounting Plate Continued											
PHQ1131F0060 K813VF0400 MT30	240.1	38409/160	2,800	2,500	3,600	4	18.43	2,508.0	13,000	22,000	33,618
PHQ1131F0060 K813VF0400 MT40	240.1	38409/160	2,800	2,500	3,500	4	22.43	2,567.4	13,000	22,000	33,618
PHQ1131F0060 K813VF0400 MT50	240.1	38409/160	2,500	2,500	3,000	4	32.43	2,605.1	13,000	22,000	40,000
PHQ1131F0060 K813VF0440 MT30	265.5	531/2	2,800	2,500	3,600	4	15.26	2,528.3	13,000	22,000	34,123
PHQ1131F0060 K813VF0440 MT40	265.5	531/2	2,800	2,500	3,500	4	19.26	2,577.4	13,000	22,000	34,123
PHQ1131F0060 K813VF0440 MT50	265.5	531/2	2,500	2,500	3,000	4	29.26	2,608.4	13,000	22,000	34,123
PHQ1131F0060 K813VF0490 MT30	293.9	16461/56	2,800	2,500	3,600	4	14.86	2,545.2	13,000	22,000	37,779
PHQ1131F0060 K813VF0490 MT40	293.9	16461/56	2,800	2,500	3,500	4	18.86	2,585.7	13,000	22,000	37,779
PHQ1131F0060 K813VF0490 MT50	293.9	16461/56	2,500	2,500	3,000	4	28.86	2,611.1	13,000	22,000	37,779
PHQ1131F0060 K813VF0590 MT30	354.5	42539/120	2,800	2,500	3,600	4	11.69	2,569.1	13,000	22,000	40,000
PHQ1131F0060 K813VF0590 MT40	354.5	42539/120	2,800	2,500	3,500	4	15.69	2,597.4	13,000	22,000	40,000
PHQ1131F0060 K813VF0590 MT50	354.5	42539/120	2,500	2,500	3,000	4	25.69	2,614.9	13,000	22,000	40,000
PHQ1131F0060 K813VF0650 MT30	392.5	188387/480	2,800	2,500	3,600	4	11.46	2,578.9	13,000	22,000	40,000
PHQ1131F0060 K813VF0650 MT40	392.5	188387/480	2,800	2,500	3,500	4	15.46	2,602.1	13,000	22,000	40,000
PHQ1131F0060 K813VF0650 MT50	392.5	188387/480	2,500	2,500	3,000	4	25.46	2,616.5	13,000	22,000	40,000
PHQ1131F0060 K813VF0720 MT30	430.2	10325/24	2,800	2,500	3,600	4	10.01	2,586.3	13,000	22,000	40,000
PHQ1131F0060 K813VF0720 MT40	430.2	10325/24	2,800	2,500	3,500	4	14.01	2,605.6	13,000	22,000	40,000
PHQ1131F0060 K813VF0720 MT50	430.2	10325/24	2,500	2,500	3,000	4	24.01	2,617.6	13,000	22,000	40,000
PHQ1131F0060 K813VF0790 MT30	476.3	45725/96	2,800	2,500	3,600	4	9.85	2,593.0	13,000	22,000	40,000
PHQ1131F0060 K813VF0790 MT40	476.3	45725/96	2,800	2,500	3,500	4	13.85	2,608.9	13,000	22,000	40,000
PHQ1131F0060 K813VF0790 MT50	476.3	45725/96	2,500	2,500	3,000	4	23.85	2,618.7	13,000	22,000	40,000
PHQ1131F0060 K813VF0880 MT30	526.6	21063/40	2,800	2,500	3,600	4	8.78	2,598.5	13,000	15,099	20,480
PHQ1131F0060 K813VF0880 MT40	526.6	21063/40	2,800	2,500	3,500	4	12.78	2,611.5	13,000	15,099	20,480
PHQ1131F0060 K813VF0970 MT30	583.0	93279/160	2,800	2,500	3,600	4	8.68	2,603.0	13,000	16,717	22,674
PHQ1131F0060 K813VF0970 MT40	583.0	93279/160	2,800	2,500	3,500	4	12.68	2,613.6	13,000	16,717	22,674

PHQK

Index of Symbols: MT — Motor adapter with TriAdapt® coupling
 L — Large Input
 C — ServoCool

Max. Motor Shaft Diameter					
Adapter	Shaft	Adapter	Shaft	Adapter	Shaft
MT10	19	MT30	38	MT50	60
MT20	24	MT40	48		

See Page 154 for Options and Part Number Configuration.



"PHQK" Series – Right Angle ServoFit® Precision Planetary Gearhead Dimensional Data



PHQK

S⁴ Dia. x T⁴ Deep
12 Holes Located as
Shown on E Bolt Circle

PHQ7_K – PHQ8_K

S¹ Dia., 24 Holes
Located as Shown
on E¹ Bolt Circle

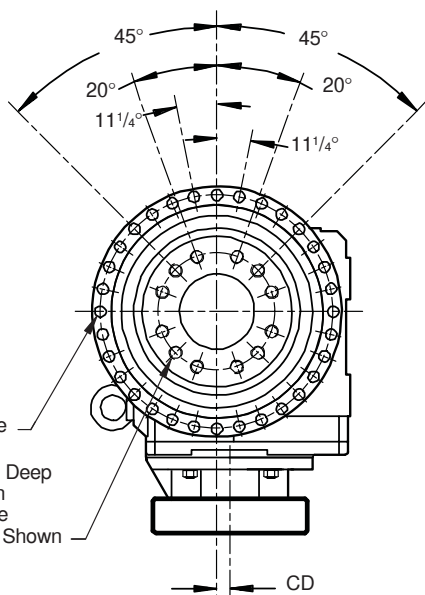
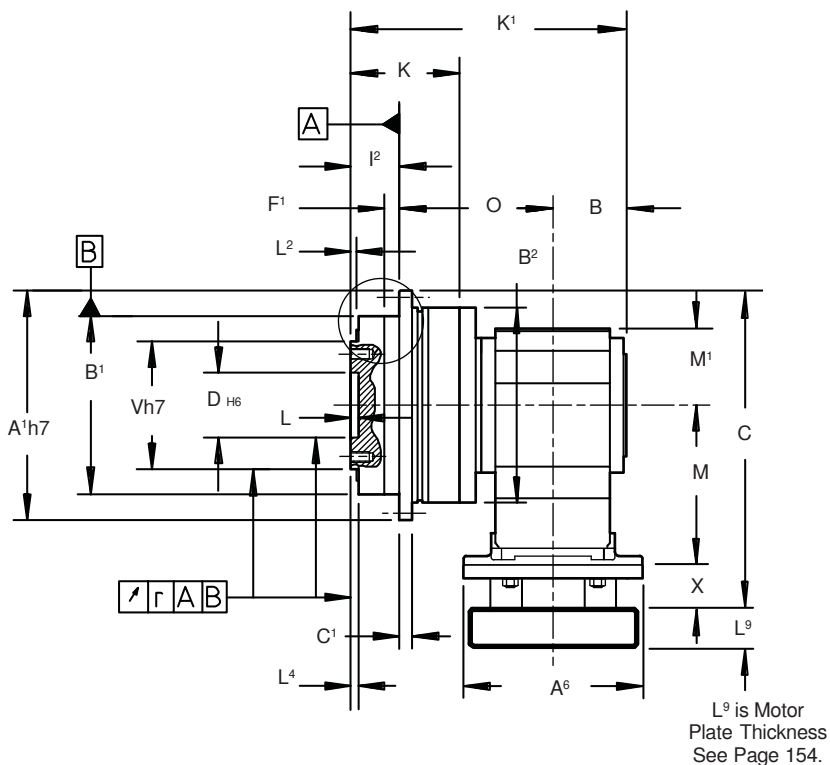
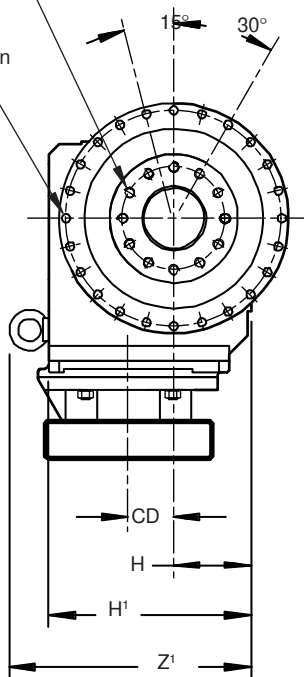

PHQ9_K/PHQ11_K

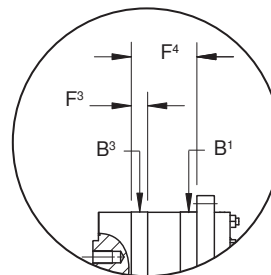

Dimensions for PHQ11_K ONLY

Unit	B ³	F ³	F ⁴
PHQ1131_K8	365 _{h6}	30	120

Part No. Example

PHQ721F0055K202VF0040MT10

Specify: Mounting Position
Side 3 or 4 for PHQ
Paint, if not **Black**
Motor Information



"PHQK" Series – Right Angle ServoFit® Precision Planetary Gearhead Dimensional Data



Table No. 1 "PHQK" Series – Gearhead with Motor Plate – Dimensions (mm/inches)

Unit	A ¹	B	B ¹	B ²	C ¹	D	E	E ¹	F ¹	H	H ¹	I ²	K	K ¹	L	L ²	L ⁴	M ¹	O	R
PHQ721_K202	179	70	140 ^{h7}	152	10	50	80	168	12	65	190	38	88	242	6	6	6	65	134	.025
PHQ821_K402	247	90	200 ^{h7}	212	12	80	125	233	15	90	240	50	126	327.5	8	8	9	90	187.5	.030
PHQ931_K513	300	96	255 ^{h7}	255	18	90	145	280	20	160	260	66	145	358.5	12	11	12	100	196.5	.030
PHQ1031_K713	330	116.5	285 ^{h7}	—	20	95	166	310	20	212	342	75	160	429.5	10	15	15	125	238	.040
PHQ1131_K813	425	149	365 ^{h6}	365	32	120	200	395	30	265	410	190	222	579.5	10	—	10	145	240.5	.040

Table No. 2 "PHQK" Series – (mm)

Unit	S ¹	S ⁴	T ⁴	V	Z ₁
PHQ721_K202	6.6	M10	16	100	—
PHQ821_K402	9	M12	17	160	—
PHQ931_K513	13.5	M20	28	180	312
PHQ1031_K713	13.5	M24	35	200	403
PHQ1131_K813	17.5	M24	36	260	471

Table No. 3 "PHQK" Dimensions

Motor Adapter	Motor Shaft D ⁶ Max. ¹⁾	Thickness ²⁾ L ⁹ Min.	A ⁶	X	Wt. lbs.
MT10	19	21	140	40	5
MT20	24	24	160	50	8
MT30	38	25	200	60	12
MT40	48	33	250	50	18
MT50	60	43	300	60	16

- ¹⁾ If an adapter bushing is required it will be supplied as a component of the motor mounting plate.
²⁾ Motor plate maximum thickness (L⁹) will vary with motor shaft length but will not be less than shown.

Table No. 4 "PHQK" Series – ServoFit Precision Planetary Gearhead (mm/inches)

Base Module	MT10			MT20			MT30			MT40			MT50			Wt. lbs.
	CD	C	M	CD	C	M	CD	C	M	CD	C	M	CD	C	M	
PHQ721_K202	46	272.5	143	46	276.5	147	46	278.5	149	—	—	—	—	—	—	67
PHQ821_K402	—	—	—	60	360.5	187	60	362.5	189	60	365.5	192	—	—	—	157
PHQ931_K513	—	—	—	15	372	172	15	384	174	15	377	177	—	—	—	213
PHQ1031_K713	—	—	—	—	—	—	20	446	221	20	439	224	20	462	237	345
PHQ1131_K813	—	—	—	—	—	—	24	519.5	247	24	511.5	249	24	534.5	262	672

See Page 154 for Options and Part Number Configuration.

"KS" Series – Right Angle ServoFit® Precision Planetary Gearhead Performance Specification Overview



			KS402	KS403	KS502	KS503	KS702	KS703
Acceleration Torque	M _{2B} MAX	in.lbs. Nm	797 90		1,772 200		3,543 400	
Output Torque Nom. ¹⁾	M _{2N}	in.lbs. Nm	576 65		1,150 130		2,215 250	
Input Speed Max.	n ₁ MAX	Continuous Cyclic	4,000 6,000	4,500	3,500 6,000	4,200	3,200 6,000	4,000
Torsional Backlash Max. ²⁾	Δφ	arcmin	≤6		≤5		≤4	
Torsional Stiffness	C ₂	in.lbs./arcmin Nm/arcmin	≤75.3 ≤8.5		≤150.6 ≤17		≤372 ≤42	
Axial Load ³⁾ Output — G/P Maximum	F ₂ MAX	lbs. N	765 3,400		1,350 6,000		2,250 10,000	
Output — F		lbs. N	900 4,000		1,350 6,000		2,250 10,000	
Output — S		lbs. N	900 4,000		1,350 6,000		2,250 10,000	
Radial Load ³⁾ Maximum — Output — G/P	F ₂ R MAX	lbs. N	1,125 5,000		1,800 8,000		2,250 10,000	
Tilting Moment ³⁾ Maximum — Output — F/S	M _{2K} max	in.lbs. Nm	1,859 210		4,071 460		6,903 780	
Weight	m	pounds kg	18.5 8.4	18.1 8.2	30 13.6	31.8 14.4	59.1 26.8	62 28.1
Noise Level ⁴⁾	L _{PA}	dB(A)	≤65		≤62		≤63	
Efficiency (at Nom. Torque)	h	%	≥ 93% — 95%					
Degree of Protection	IP65 - FKM Shaft Seals							
Mounting	Any HORIZONTAL. Vertical must be Specified. See Page 169.							
Lubrication	Synthetic Oil — Lubricated for Life							
Temperature	0° C to +40° C (104° F) [Unit temperature ≤ 90° C Max.]							
Finish	Black (RAL 9005)							
Bearing Lifetime ⁵⁾	L _h	hours	L _h > 10,000 hours if M _{2K} /T _{2A} < 1.25 L _h > 20,000 hours if M _{2K} /T _{2A} > 1.25 L _h > 30,000 hours if M _{2K} /T _{2A} > 1.5					
Warranty	5 Year Limited (2 Years on normal wear items: bearings, seals, etc.)							

¹⁾ Ratings based on input speed (n₁) of 2000 RPM.

For torque at higher input speeds (M_{2NX}) solve the formula, where n₁ = Actual Input Speed.

$$M_{2NX} = \frac{M_{2N}}{\sqrt[3]{\frac{n_1}{2000}}}$$

²⁾ Tested at 1.5% of nominal torque and recorded on the output side of the gearhead.

³⁾ Rating based on output speed (n₂) of 100 RPM. For values at other speeds see Page 170.

⁴⁾ Measurement at one (1) meter distance with input speed (n₁) of 3000 RPM.

⁵⁾ T_{2A} equals actual tilting moment of the application. See Page 170 for calculation details.

KS

WARNING: In order to insure that the specified torque ratings are attained, it is essential to use a grade 10.9 or greater fastener on all output connections.

Refer to Page 302 for ServoFit Precision Planetary Gearhead Selection Procedure.



"KS" Series – Right Angle ServoFit® Precision Planetary Gearhead Features

The "KS" Series ServoFit Right Angle Precision Planetary Gearhead uses time-tested helical gearing and finish ground spiral bevel gears to provide a low backlash unit, that is smooth running, with high efficiency, high power density, and high input speed capacity.

Some other features are:

- Readily Attaches to Any Servo Motor (IEC, NEMA, or Customized Motor Plates)
- 5 Year Limited Warranty (2 years on bearings, seals, etc.)
- Low Backlash
- High Input Speeds
- Ratios up to 200:1
- Advanced Gear Technology
- Up to 95% Efficiency
- Quiet Running
- IP65 Protection
- Assembled in the U.S.A.

High gear quality provided in case-hardened and finish-ground sun, planetary, and spiral bevel gears for backlash stability and quiet running

FKM seals for the smallest possible diameter—reduces friction and heat buildup, increases efficiency, and allows continuous duty without additional cooling.

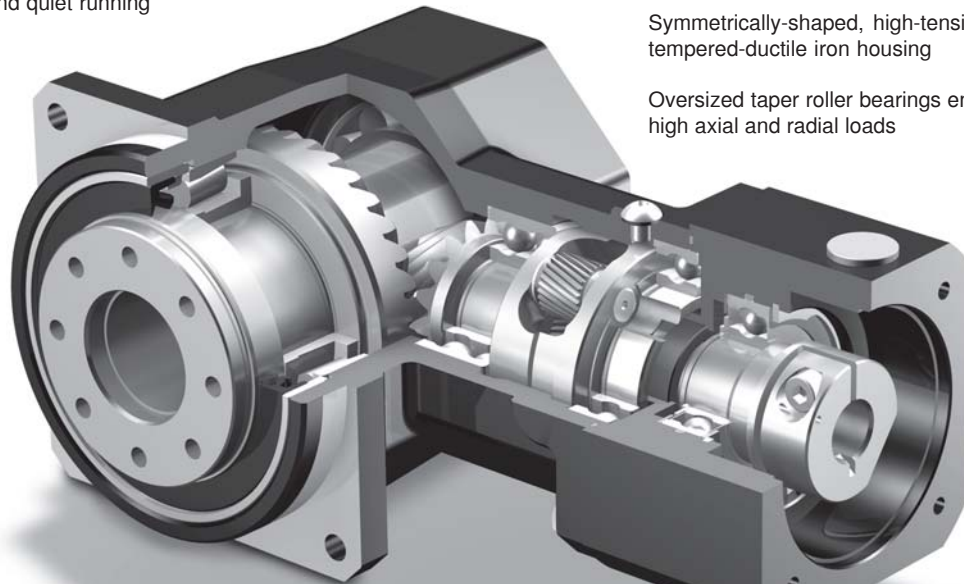

Symmetrically-shaped, high-tensile, tempered-ductile iron housing

Oversized taper roller bearings enable high axial and radial loads

Lubricated for life with high-quality synthetic oil. Input bearing with shields and high temperature grease provide maintenance free operation.

Motor plate pilot toleranced to fit your motor for precise concentricity

Motor plate can easily be changed to fit your choice of motors

The patented motor coupling is designed to allow thermal expansion of the motor shaft — ensuring long motor life by preventing thrust load on the motor bearings.

The motor shaft adapter system allows installation of motor in minutes — no special tools required





“KS” Series – Right Angle ServoFit® Precision Planetary Gearhead

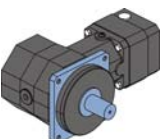

Part No. Explanation

KS 5 0 2 P F 0060 MT L

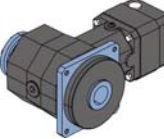
Series	Size	Generation	No. of Gear Stages	Shaft Style	Standard Housing	Ratio:1	Motor Adapter Option	Large Input
Series	KS	Concentric Helical (output and input in line/gears are all helical)						
Size	5	4, 5, 7						
Generation	0	First generation 0 , second generation 1, etc.						
No. of Gear Stages	2	2 , 3 (determined by the ratio)						
Output Style	P	Shaft with Key 						
	G	Shaft without Key 						
	F	Flanged Hollow Output 						
	S	Shrink Ring Output 						
Ratio	0060	Exact: 0060 = 6.0:1 (range of 6:1 up to 200:1)						
Motor Adapter	MT	Motor Adapter (Motor information must be specified,)						
Option	L	Large Input Motor Adapter						

KS



“KS” Series – Right Angle ServoFit® Precision Planetary Gearhead

Motor Mounting Specifications

STOBER ServoFit Gearheads will fit the motor of your choice by assembling the correct motor mounting plate between the motor and the gearhead. **When ordering a gearhead, specify the motor manufacturer and part number, provide the motor drawing with dimensions, or specify the motor mounting dimensions.** The motor plate thickness (L^9) dimension will be determined by the motor shaft length. The minimum motor plate thickness is shown below. For a precise dimension on a specific motor, contact STOBER Technical Support.

The following dimensions are required to provide the correct motor mounting plate:

1. D^6 Motor Shaft Diameter (If an adapter bushing is required it will be supplied with the motor plate.)
2. D^7 Pilot Diameter
3. D^8 Bolt Circle Diameter
4. D^9 Bolt Diameter
5. L^{11} Motor Shaft Length
6. L^{12} Pilot Length
7. L^{14} Square Flange (Optional — Motor plate will typically be made to match.)

Table No. 1

Motor Plate Dims.	Planetary Size			
	KS403	KS402 KS503	KS502 KS703	KS702
D^6 Max.	14	19	24	32
L^9 Min.	15	18	21	24

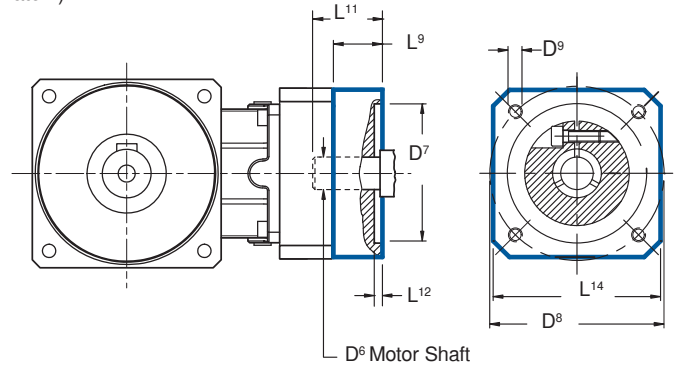

Mounting Position – Any Horizontal

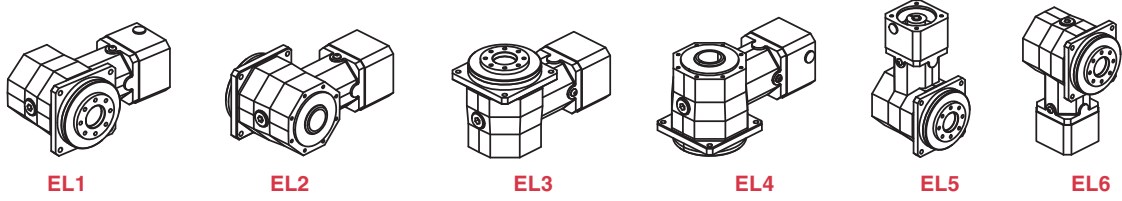

Vertical Mounting Position
MUST BE SPECIFIED
EL5 Mounting is not possible on 3 stage units.

Direction of Rotation

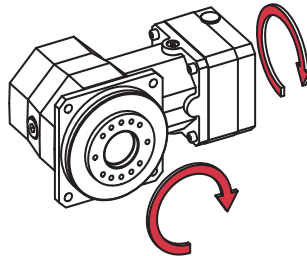

"KS" Series – Right Angle ServoFit® Precision Planetary Gearhead Shaft Loads



All formulas shown are based on METRIC values.

Upper case letters are permissible values. Lower case letters are for existing values.

The permissible load and tilting moment values are based on an output speed of 100 RPM. For higher speeds the following applies, where n_2 is the desired speed:

$$F_{2AX} = \frac{F_{2A}}{\sqrt[3]{\frac{n_2}{100}}} \quad F_{2RX} = \frac{F_{2R}}{\sqrt[3]{\frac{n_2}{100}}} \quad M_{2KX} = \frac{M_{2K}}{\sqrt[3]{\frac{n_2}{100}}}$$

The application input tilting moment should be determined by the following formula: **Type G/P** $M_{2A} = \frac{2 \cdot F_{2a} \cdot y_2 + F_{2rb} \cdot (X_2 + Z_2)}{1000} \leq M_{2KB}$

- where:
- F_{2a} Axial Load at Output Shaft
 - F_{2A} Permissible Axial Load
 - F_{2r} Radial Load at Output Shaft
 - F_{2R} Permissible Radial Load
 - F_{2RB} Acceleration Permissible Radial Load
 - M_{2K} Rated Tilting Torque
 - M_{2k} Equivalent Tilting Load
 - M_{2KB} Acceleration Tilting Torque
 - Z_2 Distance Factor

Type F/S $M_{2A} = \frac{F_{2a} \cdot y_2 + F_{2rb} \cdot (X_2 + Z_2)}{1000} \leq M_{2KB}$

$$M_{2ka} = \sqrt[3]{\frac{n_{2b1} \cdot t_{b1} \cdot M_{2kb1}^3 + \dots + n_{2bn} \cdot t_{bn} \cdot M_{2kbn}^3}{n_{2b1} \cdot t_{b1} + \dots + n_{2bn} \cdot t_{bn}}} \leq M_{2k}$$

$$F_{2r} = \sqrt[3]{\frac{n_{2b1} \cdot t_{b1} \cdot F_{2rb1}^3 + \dots + n_{2bn} \cdot t_{bn} \cdot F_{2rbn}^3}{n_{2b1} \cdot t_{b1} + \dots + n_{2bn} \cdot t_{bn}}} \leq F_{2R}$$

The hours of life (L_h) of the unit can be determined by the following formula:

bearing life for duty cycle $\leq 40\%$

- $L_h > 10,000$ hours if $M_{2k}/M_{2A} < 1.25$ and > 1
- $L_h > 20,000$ hours if $M_{2k}/M_{2A} > 1.25$ and > 1.5
- $L_h > 30,000$ hours if $M_{2k}/M_{2A} < 1.5$

bearing life for duty cycle $\geq 40\%$

$$L_{hA} = L_h \left(\frac{40\%}{\text{Duty Cycle}} \right)$$

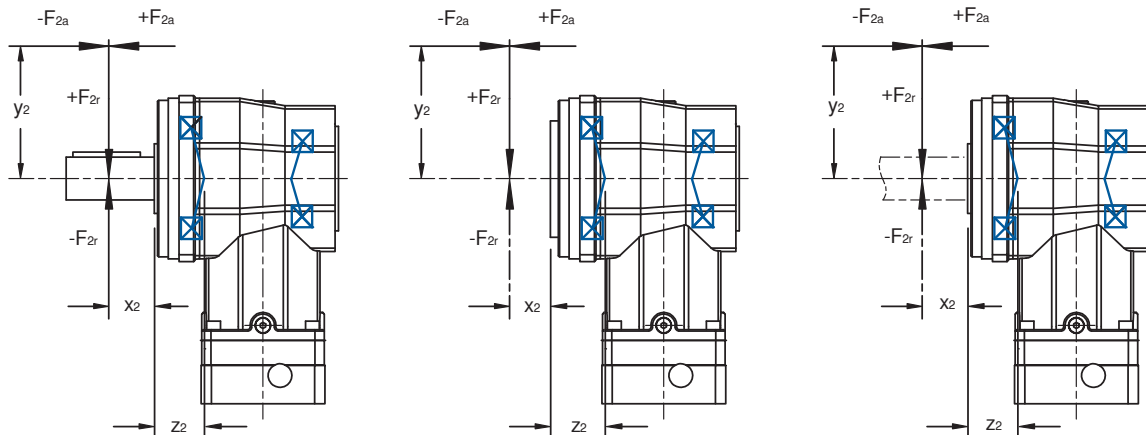

Table No. 1 Permissible Load and Tilting Moments

G/P – Solid Shaft

Unit No.	Z_2		F_{2A}		F_{2R}		F_{2RB}		M_{2K}		M_{2KB}	
	mm	inches	N	lbs.	N	lbs.	N	lbs.	Nm	in.lbs.	Nm	in.lbs.
KS4	34	1.34	3,400	765	5,000	1,125	5,000	1,125	260	2,301	260	2,301
KS5	40	1.57	6,000	1,350	8,000	1,800	8,000	1,800	550	4,868	550	4,868
KS7	51	2.01	10,000	2,250	10,000	2,250	10,000	2,250	920	8,142	920	8,142

F – Flange Hollow Output

Unit No.	Z_2		F_{2A}		F_{2R}		F_{2RB}		M_{2K}		M_{2KB}	
	mm	inches	N	lbs.	N	lbs.	N	lbs.	Nm	in.lbs.	Nm	in.lbs.
KS4	38	1.50	4,000	900	6,842	1,539	10,263	2,309	260	2,301	390	3,452
KS5	45	1.77	6,000	1,350	12,222	2,750	18,333	4,125	550	4,868	825	7,301
KS7	55	2.17	10,000	2,250	16,727	3,764	25,091	5,645	920	8,142	1,380	12,213

S – Hollow Output with Shrink Ring

Unit No.	Z_2		F_{2A}		F_{2R}		F_{2RB}		M_{2K}		M_{2KB}	
	mm	inches	N	lbs.	N	lbs.	N	lbs.	Nm	in.lbs.	Nm	in.lbs.
KS4	36	1.42	4,000	900	5,000	1,125	5,000	1,125	260	2,301	260	2,301
KS5	42	1.65	6,000	1,350	8,000	1,800	8,000	1,800	550	4,868	550	4,868
KS7	52	2.05	10,000	2,250	10,000	2,250	10,000	2,250	920	8,142	920	8,142

During EMERGENCY OFF operation (maximum stops per gearhead = 1000) the permissible values in the table for F_{2A} , F_{2R} , and M_{2K} can be multiplied by a factor of 2.



"KS" Series – Right Angle ServoFit® Precision Planetary Gearhead Shaft Loads

Permissible Motor Tilting Torque

The permissible tilting torque of the motor attached to the gear unit is a result of the static and dynamic load "F" from the motor weight, mass acceleration, and vibration multiplied by the distance from the center of gravity "ls" of the motor. $M_{1k} = F \times l_s \leq M_{1k}$

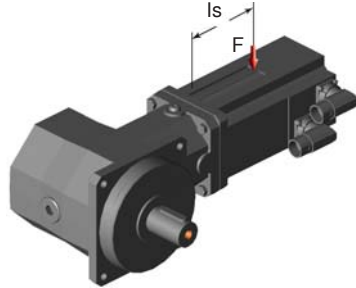

Table No. 1

M_{1k}

Unit Type with MT	M _{1k}	
	Nm	inlbs.
KS403	10	88.5
KS402, KS503	20	177
KS502, KS703	40	354
KS702	80	708





"KS" Series – Right Angle ServoFit® Precision Planetary Gearhead Selection Data



Part Number (Gearhead + Input)	Exact Ratio i	Maximum Input Speed		Maximum Motor Shaft øD ⁶ mm	Input ¹⁾ Inertia J ₁ kgcm ²	Torsional Stiffness per arcmin C ₂		Output Torque					
		Continuous RPM (n ₁)	Cyclic RPM (n ₁)			in.lbs.	Nm	Nominal ²⁾		Acceleration		Peak ³⁾	
								M _{2N}	M _{2B}	M _{2PEAK}	M _{2PEAK}		

KS402 with Motor Mounting Plate

KS402_0060 MT	6.000	3,000	6,000	19	1.24	71.7	8.1	531	60	797	90	1,240	140
KS402_0060 MTL	6.000	3,000	6,000	24	1.92	74.3	8.4	531	60	797	90	1,240	140
KS402_0080 MT	8.000	3,500	6,000	19	0.89	73.5	8.3	576	65	797	90	1,240	140
KS402_0080 MTL	8.000	3,500	6,000	24	1.58	74.3	8.4	576	65	797	90	1,240	140
KS402_0100 MT	10.000	3,800	6,000	19	0.76	73.5	8.3	576	65	797	90	1,240	140
KS402_0100 MTL	10.000	3,800	6,000	24	1.45	74.3	8.4	576	65	797	90	1,240	140
KS402_0140 MT	14.000	4,000	6,000	19	0.65	74.3	8.4	576	65	797	90	1,240	140
KS402_0140 MTL	14.000	4,000	6,000	24	1.32	75.3	8.5	576	65	797	90	1,240	140
KS402_0200 MT	20.000	4,000	6,000	19	0.60	75.3	8.5	531	60	797	90	1,240	140
KS402_0200 MTL	20.000	4,000	6,000	24	1.28	75.3	8.5	531	60	797	90	1,240	140

KS403 with Motor Mounting Plate

KS403_0240 MT	24.000	3,500	6,000	14	0.20	74.9	8.5	531	60	797	90	1,240	140
KS403_0240 MTL	24.000	3,500	6,000	19	0.67	75.3	8.5	531	60	797	90	1,240	140
KS403_0320 MT	32.000	3,500	6,000	14	0.17	75.1	8.5	576	65	797	90	1,240	140
KS403_0320 MTL	32.000	3,500	6,000	19	0.65	75.3	8.5	576	65	797	90	1,240	140
KS403_0400 MT	40.000	3,500	6,000	14	0.17	75.2	8.5	576	65	797	90	1,240	140
KS403_0400 MTL	40.000	3,500	6,000	19	0.64	75.3	8.5	576	65	797	90	1,240	140
KS403_0500 MT	50.000	4,000	6,000	14	0.13	75.2	8.5	576	65	797	90	1,240	140
KS403_0500 MTL	50.000	4,000	6,000	19	0.61	75.3	8.5	576	65	797	90	1,240	140
KS403_0700 MT	70.000	4,500	6,000	14	0.11	75.2	8.5	576	65	797	90	1,240	140
KS403_0700 MTL	70.000	4,500	6,000	19	0.57	75.3	8.5	576	65	797	90	1,240	140
KS403_0800 MT	80.000	4,500	6,000	14	0.10	75.2	8.5	576	65	797	90	1,240	140
KS403_0800 MTL	80.000	4,500	6,000	19	0.57	75.3	8.5	576	65	797	90	1,240	140
KS403_1000 MT	100.000	4,500	6,000	14	0.10	75.3	8.5	576	65	797	90	1,240	140
KS403_1000 MTL	100.000	4,500	6,000	19	0.57	75.3	8.5	576	65	797	90	1,240	140
KS403_1400 MT	140.000	4,500	6,000	14	0.10	75.3	8.5	576	65	797	90	1,240	140
KS403_1400 MTL	140.000	4,500	6,000	19	0.56	75.3	8.5	576	65	797	90	1,240	140
KS403_2000 MT	200.000	4,500	6,000	14	0.10	75.3	8.5	531	60	797	90	1,240	140
KS403_2000 MTL	200.000	4,500	6,000	19	0.56	75.3	8.5	531	60	797	90	1,240	140

KS502 with Motor Mounting Plate

KS502_0060 MT	6.000	2,500	5,500	24	2.90	141.6	16.0	886	100	1,772	200	2,657	300
KS502_0060 MTL	6.000	2,500	5,500	32	5.12	150.6	17.0	886	100	1,772	200	2,657	300
KS502_0080 MT	8.000	2,800	6,000	24	2.26	150.6	17.0	1,150	130	1,772	200	2,657	300
KS502_0080 MTL	8.000	2,800	6,000	32	4.49	150.6	17.0	1,150	130	1,772	200	2,657	300
KS502_0100 MT	10.000	3,000	6,000	24	1.87	150.6	17.0	1,150	130	1,772	200	2,657	300
KS502_0100 MTL	10.000	3,000	6,000	32	4.10	150.6	17.0	1,150	130	1,772	200	2,657	300
KS502_0140 MT	14.000	3,200	6,000	24	1.52	150.6	17.0	1,150	130	1,772	200	2,657	300
KS502_0140 MTL	14.000	3,200	6,000	32	3.79	150.6	17.0	1,150	130	1,772	200	2,657	300
KS502_0200 MT	20.000	3,500	6,000	24	1.33	150.6	17.0	1,063	120	1,772	200	2,657	300
KS502_0200 MTL	20.000	3,500	6,000	32	3.60	150.6	17.0	1,063	120	1,772	200	2,657	300

KS503 with Motor Mounting Plate Continued Next Page

KS503_0240 MT	24.000	3,100	6,000	19	0.83	150.6	17.0	886	100	1,772	200	2,657	300
KS503_0240 MTL	24.000	3,100	6,000	24	1.51	150.6	17.0	886	100	1,772	200	2,657	300
KS503_0320 MT	32.000	3,100	6,000	19	0.79	150.6	17.0	1,150	130	1,772	200	2,657	300
KS503_0320 MTL	32.000	3,100	6,000	24	1.47	150.6	17.0	1,150	130	1,772	200	2,657	300

¹⁾ Inertia based on maximum input. For lower inertia using smaller diameter input, contact STOBER.

²⁾ Based on input speed: n₁ = 2000 RPM

For torque at higher input speeds (M_{2NX}) solve the formula, where n₁ = Actual Input Speed.
$$M_{2NX} = \frac{M_{2N}}{\sqrt[3]{\frac{n_1}{2000}}}$$

³⁾ Maximum momentary torque for emergency stops or heavy shock load. Admissible stops per life of gearhead = 1,000 stops maximum.



"KS" Series – Right Angle ServoFit® Precision Planetary Gearhead Selection Data



Part Number (Gearhead + Input)	Exact Ratio i	Maximum Input Speed		Maximum Motor Shaft øD ⁶ mm	Input ¹⁾ Inertia J ₁ kgcm ²	Torsional Stiffness per arcmin		Output Torque					
		Continuous RPM (n ₁)	Cyclic			C ₂		Nominal ²⁾		Acceleration		Peak ³⁾	
						in.lbs.	Nm	M _{2N}	Nm	M _{2B}	Nm	M _{2PEAK}	Nm

KS503 with Motor Mounting Plate *Continued*

KS503_0400 MT	40.000	3,100	6,000	19	0.76	150.6	17.0	1,150	130	1,772	200	2,657	300
KS503_0400 MTL	40.000	3,100	6,000	24	1.45	150.6	17.0	1,150	130	1,772	200	2,657	300
KS503_0500 MT	50.000	3,500	6,000	19	0.68	150.6	17.0	1,150	130	1,772	200	2,657	300
KS503_0500 MTL	50.000	3,500	6,000	24	1.36	150.6	17.0	1,150	130	1,772	200	2,657	300
KS503_0700 MT	70.000	4,200	6,000	19	0.61	150.6	17.0	1,150	130	1,772	200	2,657	300
KS503_0700 MTL	70.000	4,200	6,000	24	1.28	150.6	17.0	1,150	130	1,772	200	2,657	300
KS503_0800 MT	80.000	4,200	6,000	19	0.59	150.6	17.0	1,150	130	1,772	200	2,657	300
KS503_0800 MTL	80.000	4,200	6,000	24	1.26	150.6	17.0	1,150	130	1,772	200	2,657	300
KS503_1000 MT	100.000	4,200	6,000	19	0.58	150.6	17.0	1,150	130	1,772	200	2,657	300
KS503_1000 MTL	100.000	4,200	6,000	24	1.25	150.6	17.0	1,150	130	1,772	200	2,657	300
KS503_1400 MT	140.000	4,200	6,000	19	0.58	150.6	17.0	1,150	130	1,772	200	2,657	300
KS503_1400 MTL	140.000	4,200	6,000	24	1.25	150.6	17.0	1,150	130	1,772	200	2,657	300
KS503_2000 MT	200.000	4,200	6,000	19	0.58	150.6	17.0	1,063	120	1,772	200	2,657	300
KS503_2000 MTL	200.000	4,200	6,000	24	1.25	150.6	17.0	1,063	120	1,772	200	2,657	300

KS702 with Motor Mounting Plate

KS702_0060 MT	6.000	2,100	4,500	32	9.26	354.0	40.0	2,126	240	3,543	400	5,315	600
KS702_0060 MTL	6.000	2,100	4,500	38	12.28	363.0	41.0	2,126	240	3,543	400	5,315	600
KS702_0080 MT	8.000	2,500	5,000	32	6.39	363.0	41.0	2,215	250	3,543	400	5,315	600
KS702_0080 MTL	8.000	2,500	5,000	38	9.42	363.0	41.0	2,215	250	3,543	400	5,315	600
KS702_0100 MT	10.000	2,800	6,000	32	5.31	363.0	41.0	2,215	250	3,543	400	5,315	600
KS702_0100 MTL	10.000	2,800	6,000	38	8.34	372.0	42.0	2,215	250	3,543	400	5,315	600
KS702_0140 MT	14.000	3,000	6,000	32	4.33	372.0	42.0	2,215	250	3,543	400	5,315	600
KS702_0140 MTL	14.000	3,000	6,000	38	7.38	372.0	42.0	2,215	250	3,543	400	5,315	600
KS702_0200 MT	20.000	3,200	6,000	32	3.90	372.0	42.0	2,215	250	3,543	400	5,315	600
KS702_0200 MTL	20.000	3,200	6,000	38	6.95	372.0	42.0	2,215	250	3,543	400	5,315	600

KS703 with Motor Mounting Plate

KS703_0240 MT	24.000	3,000	6,000	24	2.00	372.0	42.0	2,126	240	3,543	400	5,315	600
KS703_0240 MTL	24.000	3,000	6,000	32	4.23	372.0	42.0	2,126	240	3,543	400	5,315	600
KS703_0320 MT	32.000	3,000	6,000	24	1.83	372.0	42.0	2,215	250	3,543	400	5,315	600
KS703_0320 MTL	32.000	3,000	6,000	32	4.05	372.0	42.0	2,215	250	3,543	400	5,315	600
KS703_0400 MT	40.000	3,000	6,000	24	1.76	372.0	42.0	2,215	250	3,543	400	5,315	600
KS703_0400 MTL	40.000	3,000	6,000	32	3.98	372.0	42.0	2,215	250	3,543	400	5,315	600
KS703_0500 MT	50.000	3,200	6,000	24	1.55	372.0	42.0	2,215	250	3,543	400	5,315	600
KS703_0500 MTL	50.000	3,200	6,000	32	3.77	372.0	42.0	2,215	250	3,543	400	5,315	600
KS703_0700 MT	70.000	3,500	6,000	24	1.36	372.0	42.0	2,215	250	3,543	400	5,315	600
KS703_0700 MTL	70.000	3,500	6,000	32	3.62	372.0	42.0	2,215	250	3,543	400	5,315	600
KS703_0800 MT	80.000	4,000	6,000	24	1.30	372.0	42.0	2,215	250	3,543	400	5,315	600
KS703_0800 MTL	80.000	4,000	6,000	32	3.57	372.0	42.0	2,215	250	3,543	400	5,315	600
KS703_1000 MT	100.000	4,000	6,000	24	1.29	372.0	42.0	2,215	250	3,543	400	5,315	600
KS703_1000 MTL	100.000	4,000	6,000	32	3.56	372.0	42.0	2,215	250	3,543	400	5,315	600
KS703_1400 MT	140.000	4,000	6,000	24	1.28	372.0	42.0	2,215	250	3,543	400	5,315	600
KS703_1400 MTL	140.000	4,000	6,000	32	3.55	372.0	42.0	2,215	250	3,543	400	5,315	600
KS703_2000 MT	200.000	4,000	6,000	24	1.28	372.0	42.0	2,215	250	3,543	400	5,315	600
KS703_2000 MTL	200.000	4,000	6,000	32	3.54	372.0	42.0	2,215	250	3,543	400	5,315	600

Index of Symbols: **MT** — Motor adapter with TriAdapt® coupling; **L** — Large Input

See Page 168 for Options and Part Number Configuration.



"KS" Series – ServoFit® Right Angle Flange Housing – Shaft Output Dimensional Data



Drawing for Units
KS402PF thru KS703PF

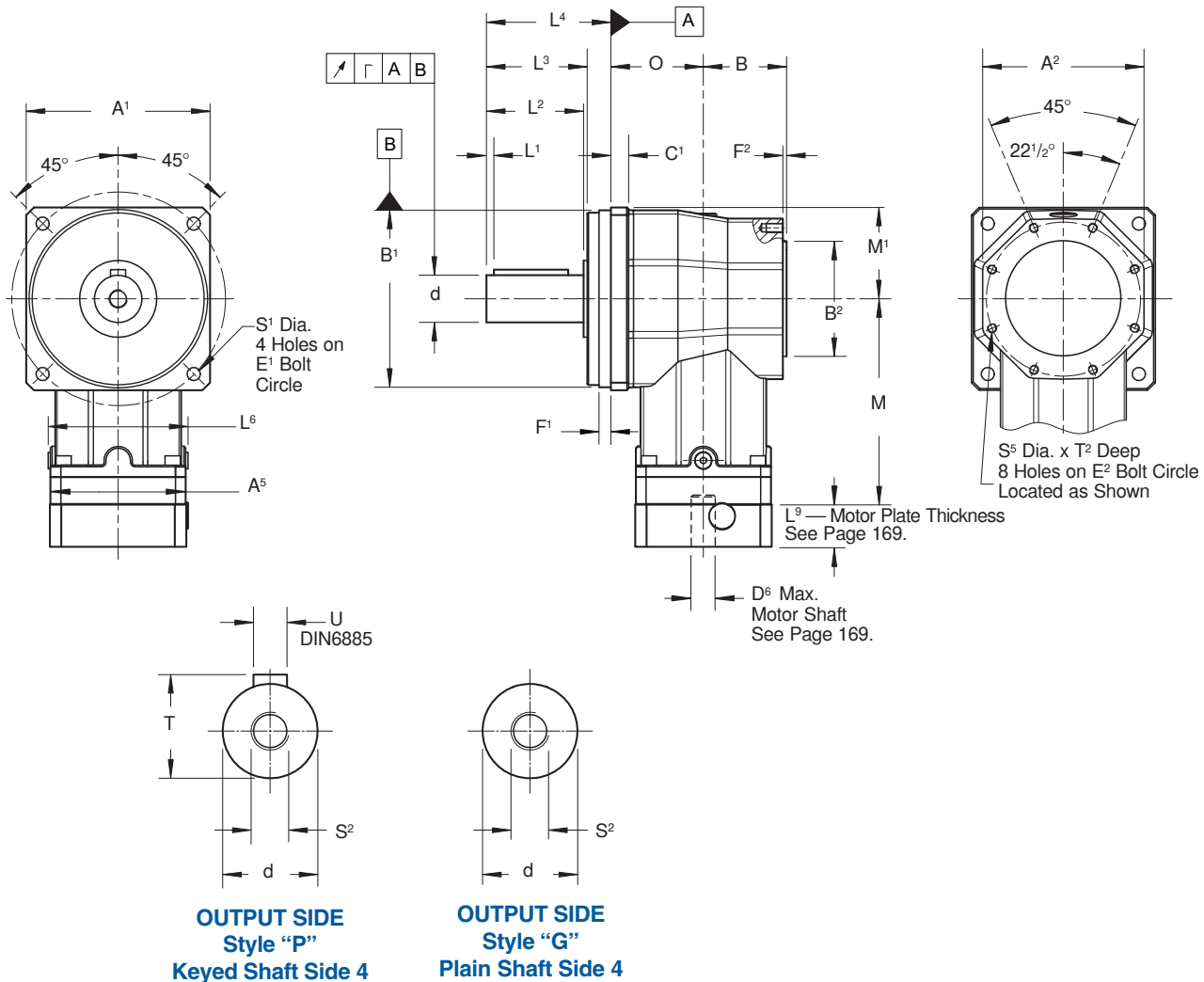

KS

Part No. Example
KS502PF0050MTL

Specify: Mounting Position
Output Style
Side of Shaft, 3 or 4
Paint, if not *Black*
Motor Information



"KS" Series – ServoFit® Right Angle Flange Housing – Shaft Output Dimensional Data



Table No. 1 "KS" Series – Right Angle Gearhead with Motor Plate – Dimensions (mm)

Unit	A ¹	A ²	B ¹	h ₆	B ²	h ₆	B	C ¹	d	k ₆	E ¹	E ²	F ¹	F ²
KS402/KS403	101	93	95	+0.00/-0.022	75	+0.00/-0.019	51	10	22	+0.015/+0.002	120	88	8	3
KS502/KS503	125	109	120	+0.00/-0.022	90	+0.00/-0.022	58	10	32	+0.018/+0.002	145	105	9	3
KS702/KS703	155	135	150	+0.00/-0.025	110	+0.00/-0.022	70	15	40	+0.018/+0.002	180	130	10	3

Table No. 2 "KS" Series – Right Angle Gearhead with Motor Plate – Dimensions (mm)

Unit	L ¹	L ²	L ³	L ⁴	L ⁶	M ¹	O	r	S ¹	S ²	S ⁵	T	T ²	U
KS402/KS403	3	36	38	52	77.5	50.5	53	.020	6.6	M8	M5	24.5	9	A6x6x28
KS502/KS503	3	58	60	75.5	98	62.5	62	.020	9	M12	M6	35	11	A10x8x50
KS702/KS703	4	82	85	105	120	77.5	78	.025	11	M16	M8	43	14	A12x8x70

Table No. 3 Dimensions (mm)

Unit	Standard		Large Input		
	A ⁵	M	Unit	A ⁵	M
KS402	72	137.5	KS402_L	100	140.8
KS403	55	121	KS403_L	75	137.5
KS502	98	158	KS502_L	115	188.5
KS503	72	156.5	KS503_L	100	181.8
KS702	115	191	KS702_L	145	205
KS703	98	186	KS703_L	115	194.5

**Drawing for Large Input Units
KS402_L thru KS703_L**

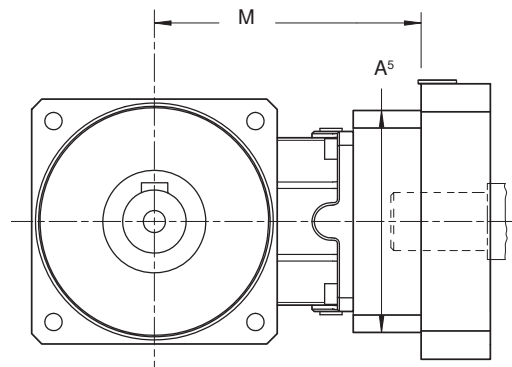

See Page 168 for Options and Part Number Configuration.



"KS" Series – ServoFit® Right Angle Flange Housing – Flange Hollow Output Dimensional Data



Drawing for Units
KS402FF thru KS703FF

OUTPUT SIDE KS4

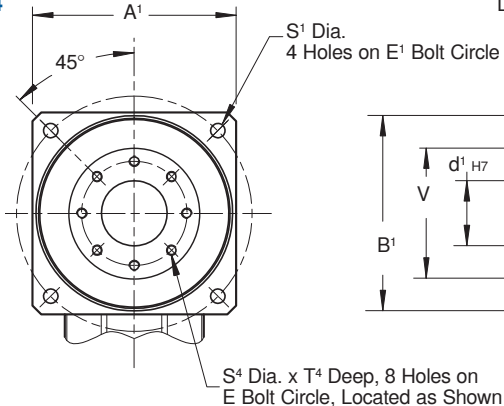

OUTPUT SIDE KS5

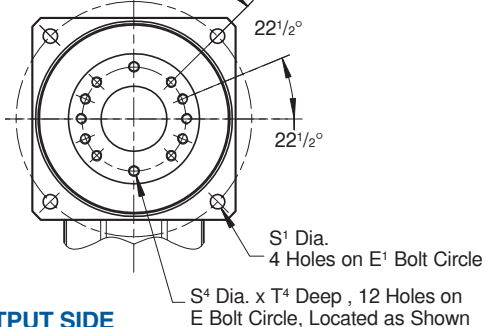

OUTPUT SIDE KS7

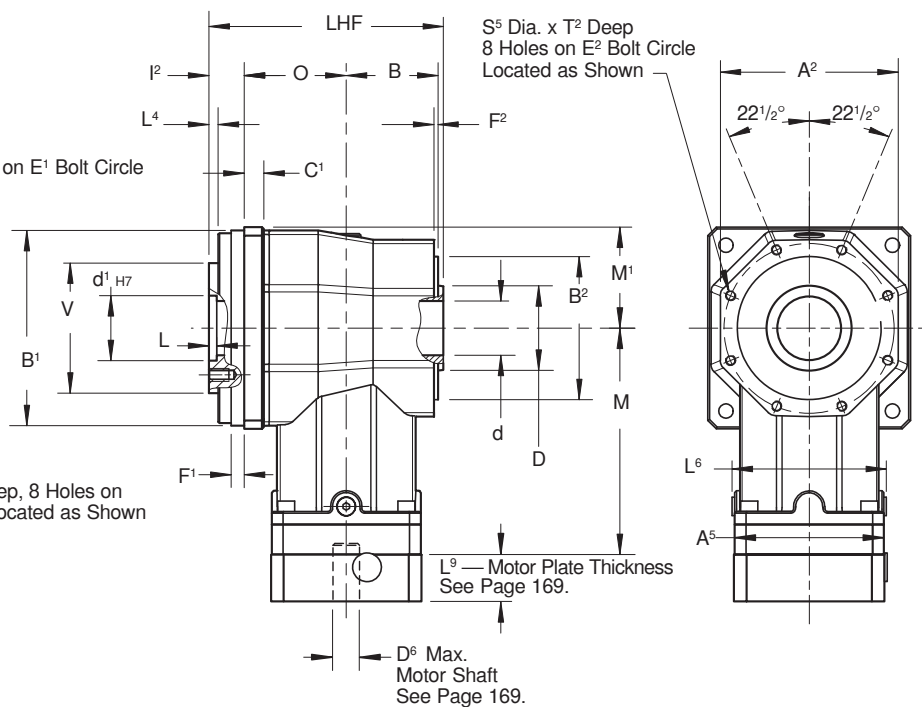
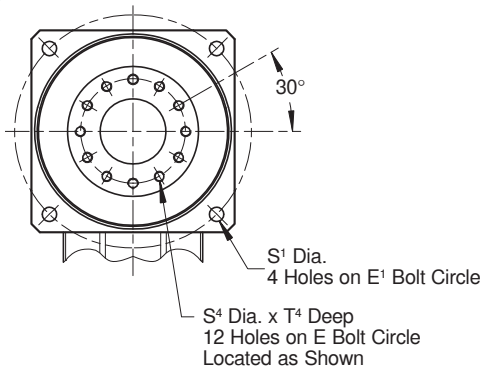

Part No. Example
KS502FF0050MTL
Specify: Mounting Position
Paint, if not *Black*
Motor Information



"KS" Series – ServoFit® Right Angle Flange Housing – Flange Hollow Output Dimensional Data



Table No. 1 "KS" Series – Right Angle Gearhead with Motor Plate – Dimensions (mm/inches)

Unit	A ¹	A ²	B ¹	h ₆	B ²	h ₆	B	C ¹	d	d ¹	H ₇	D	d ₉	E	E ¹	E ²	F ¹	F ²
KS402/KS403	101	93	95	+0.000/-0.022	75	+0.000/-0.019	51	10	30	31.5	+0.025/-0	40	-0.080/-0.180	50	120	88	8	3
KS502/KS503	125	109	120	+0.000/-0.022	90	+0.000/-0.022	58	10	38	40	+0.025/-0	48	-0.080/-0.180	63	145	105	9	3
KS702/KS703	155	135	150	+0.000/-0.025	110	+0.000/-0.022	70	15	49	50	+0.025/-0	60	-0.100/-0.174	80	180	130	10	3

Table No. 2 "KS" Series – Dimensions (mm)

Unit	I ²	L	L ⁴	L ⁶	LHF	M ¹	O	S ¹	S ⁴	S ⁵	T ²	T ⁴	V	h ₇
KS402/KS403	20	6	6	77.5	127	50.5	53	6.6	M6	M5	9	11	63	+0.000/-0.030
KS502/KS503	22	7	6.5	98	145	62.5	62	9	M6	M6	11	12	80	+0.000/-0.030
KS702/KS703	27	7	7	120	178	77.5	78	11	M8	M8	14	15	100	+0.000/-0.035

Table No. 3 Dimensions (mm)

Standard			Large Input		
Unit	A ⁵	M	Unit	A ⁵	M
KS402	72	137.5	KS402_L	100	140.8
KS403	55	121	KS403_L	75	137.5
KS502	98	158	KS502_L	115	188.5
KS503	72	156.5	KS503_L	100	181.8
KS702	115	191	KS702_L	145	205
KS703	98	186	KS703_L	115	194.5

**Drawing for Large Input Units
KS402_L thru KS703_L**

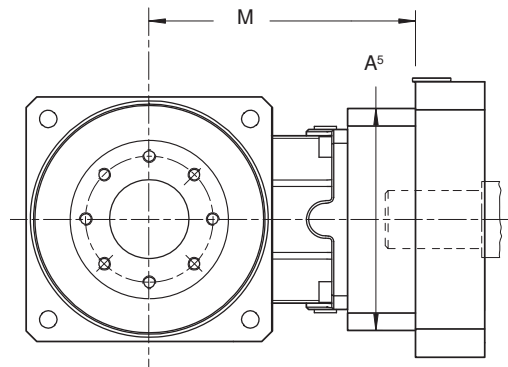

**K
S**

See Page 168 for Options and Part Number Configuration.



"KS" Series – ServoFit® Right Angle Flange Housing – Shrink Ring Output Dimensional Data



Drawing for Units
KS402 thru KS703

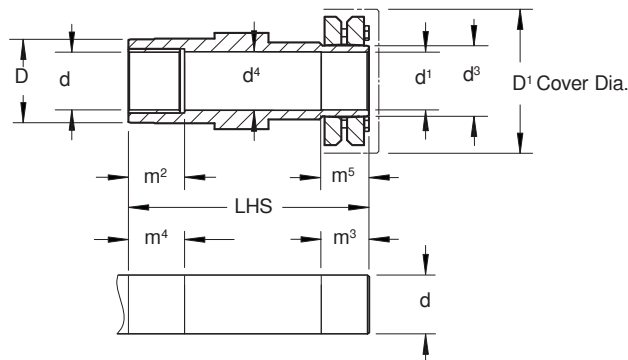
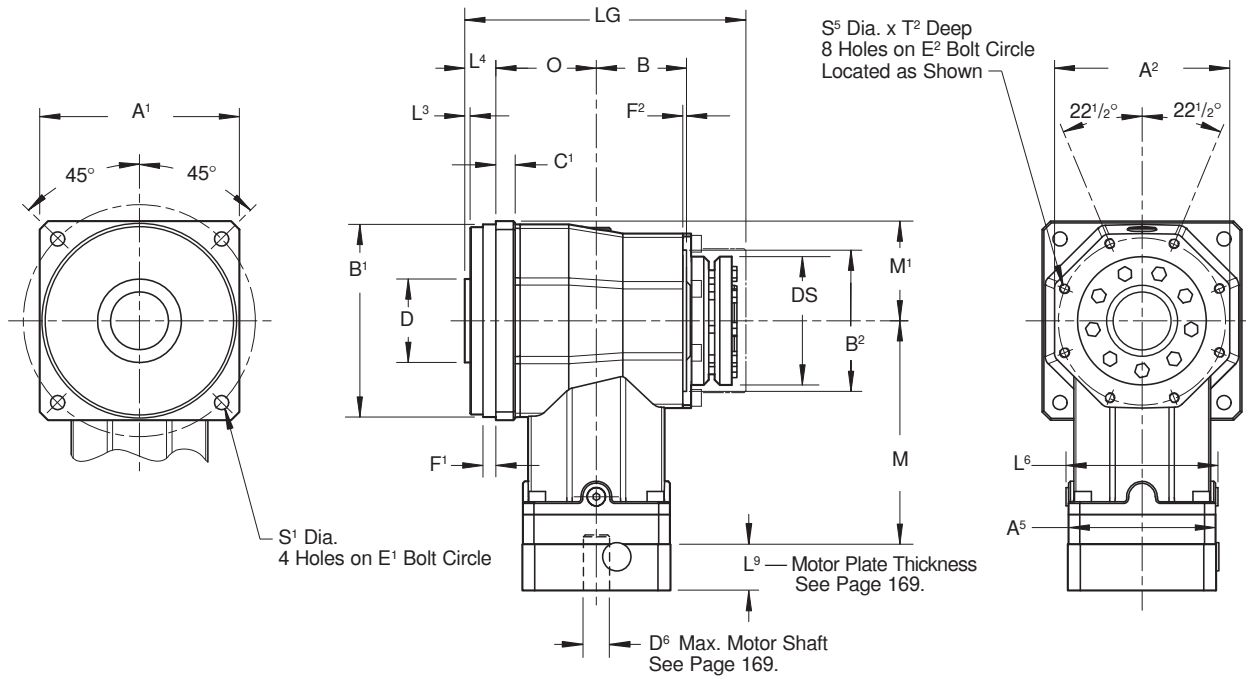

Driven shaft dimensions to fit shrink ring output.
See Page 294 for shrink ring installation.

Part No. Example
KS502SF0050MTL
Specify: Mounting Position
Paint, if not **Black**
Motor Information

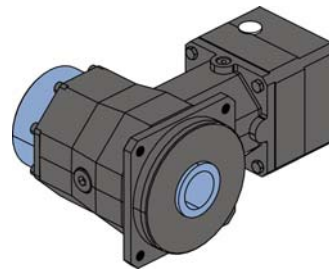

KS unit with shrink ring cover.

KS



"KS" Series – ServoFit® Right Angle Flange Housing – Shrink Ring Output Dimensional Data



Table No. 1 "KS" Series – Right Angle Gearhead with Motor Plate – Dimensions (mm)

Unit	A ¹	A ²	B ¹ h ₆	B ² h ₆	B	C ¹	d h ₉	d ¹ H ₉	d ³	d ⁴	D	D ¹	DS
KS402/KS403	101	93	95 +.000/-0.022	75 +.000/-0.019	51	10	25 +.000/-0.052	25 +.052/-0.000	30	25.5	40	72	60
KS502/KS503	125	109	120 +.000/-0.022	90 +.000/-0.022	58	10	35 +.000/-0.062	35 +.062/-0.000	44	35.5	50	92	80
KS702/KS703	155	135	150 +.000/-0.025	110 +.000/-0.022	70	15	45 +.000/-0.062	45 +.062/-0.000	55	45.5	65	112	100

Table No. 2 "KS" Series – Right Angle Gearhead with Motor Plate – Dimensions (mm)

Unit	E ¹	E ²	F ¹	F ²	I ²	L ³	L ⁴	L ⁶	LG	LHS	M ¹	m ²	m ³	m ⁴	m ⁵	O	S ¹	S ⁵	T ²
KS402/KS403	120	88	8	3	20	4	18	77.5	158	151	50.5	20	34	25	29	53	6.6	M5	9
KS502/KS503	145	105	9	3	22	4	19.5	98	179.5	171.5	62.5	30	39	35	34	62	9	M6	11
KS702/KS703	180	130	10	3	27	4	24	120	218	211	77.5	40	42	45	37	78	11	M8	14

Table No. 3 Dimensions (mm)

Standard			Large Input		
Unit	A ⁵	M	Unit	A ⁵	M
KS402	72	137.5	KS402_L	100	140.8
KS403	55	121	KS403_L	75	137.5
KS502	98	158	KS502_L	115	188.5
KS503	72	156.5	KS503_L	100	181.8
KS702	115	191	KS702_L	145	205
KS703	98	186	KS703_L	115	194.5

**K
S**

**Drawing for Large Input Units
KS402_L thru KS703_L**

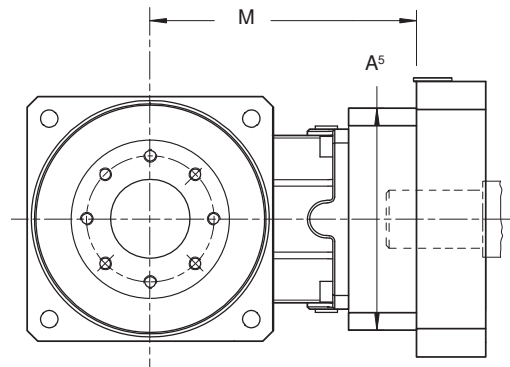

See Page 168 for Options and Part Number Configuration.

"PE" Series ServoFit® Precision Planetary Gearhead Performance Specifications



		Size	Ratio	PE201	PE202	PE301	PE302	PE401	PE402	PE501	PE502
Permissible Acceleration Torque	M _{2B}	in.lbs.	5, 25, 50	132		292		725		1,858	
			Nm		15		33		82		210
		in.lbs.	10, 100	106		265		637		1,593	
		Nm		12		30		72		180	
Nominal Output Torque ¹⁾	M _{2N}	in.lbs.		58		159		398		1,062	
		Nm		6.5		18		45		120	
Input Speed Maximum	n _{1MAX}	Continuous		4,000		3,700		3,400		2,600	
		Cyclic		8,000		6,000		6,000		5,000	
Torsional Stiffness	C ₂	in.lbs./arcmin		9		31		89		221	
		Nm/arcmin		1		3.5		10		25	
Axial Load Max.	F _{2AMAX}	lbs.		56		93		146		270	
		N		250		412		650		1,200	
Radial Load Max. ²⁾	F _{2RMAX}	lbs.		190		370		585		1,080	
		N		850		1,650		2,600		4,800	
Tilting Moment Max. ²⁾	M _{2K}	in.lbs.		221		451		991		2,973	
		Nm		25		51		112		336	
Weight	m	pounds		1.8	2.2	4.4	5.5	9.4	11.6	20.2	25.1
		kg		0.8	1.0	2.0	2.5	4.3	5.3	9.2	11.4
Noise Level ³⁾	LPA	dB(A)		≤60		≤62		≤62		≤64	
Torsional Backlash	Δφ	arcmin		1 Stage (5, 10:1) = ≤12; 2 Stage (25, 50, 100:1) = ≤15							
Efficiency (at Nominal Torque)	η	%		1 Stage (5, 10:1) = ≥96; 2 Stage (25, 50, 100:1) = ≥94							
Lubrication	Synthetic Grease (NLGI 2) Lubricated for Life										
Mounting Position	Unrestricted										
Ambient Temperature	0° C to +40°C (104° F) [Unit temperature ≤ 90° C Max.]										
Finish	Black (RAL 9005)										
Lifetime ⁴⁾	L _h	hours		L _h > 10,000 hours if M _{2K} /M _{2A} < 1.25 L _h > 20,000 hours if M _{2K} /M _{2A} > 1.25							
Warranty	5 Year Limited (2 Years on normal wear items: bearings, seals, etc.)										

- 1) Ratings based on input speed (n₁) of 2000 RPM.
For torque at higher input speeds (M_{2NX}) solve the formula, where n₁ = Actual Input Speed.
- 2) Rating based on output speed (n₂) of 100 RPM. For values at other speeds see Page 183.
- 3) Measurement at one (1) meter distance with input speed (n₁) of 3000 RPM.
- 4) M_{2A} equals actual tilting moment of the application. See Page 183 for overhung loads.

$$M_{2NX} = \frac{M_{2N}}{\sqrt[3]{\frac{n_1}{2000}}}$$



"PE" Series ServoFit® Precision Planetary Gearhead Features

The "PE" Series ServoFit Precision Planetary Gearheads are available for applications where very low backlash is not a criteria. They are an economical straight tooth planetary, comparable in quality to other STOBER units. "PE" Series units are shipped with a motor adapter to fit your specific motor, can be supplied with NEMA output adapters, and have a five year warranty. All units are lubricated for life with synthetic grease and enclosed to IP65 standards to prevent lubricant contamination for long life.

Some features of these units are:

- Readily Attaches to Any Servo Motor
- Quiet Running ≤ 64 dB(A)
- Readily Available
- Wide Selection of IEC, NEMA, or Customized* Motor Plates
- 94 to 96% Efficiency
- NEMA Output Available
- 5 Year Limited Warranty (2 Years bearings, seals, etc.)

* Maximum 10 working days for custom motor plates.



Motor plate pilot toleranced to fit your motor for precise concentricity

Ring gear machined integral to the housing — not welded or pressed in

Motor plate can easily be changed to fit your choice of motors

Gears are case hardened to 61 Rockwell "C" and refined for maximum efficiency

The integrated motor coupling is designed to allow thermal expansion of the motor shaft—ensuring long motor life by preventing thrust load on the motor bearings.

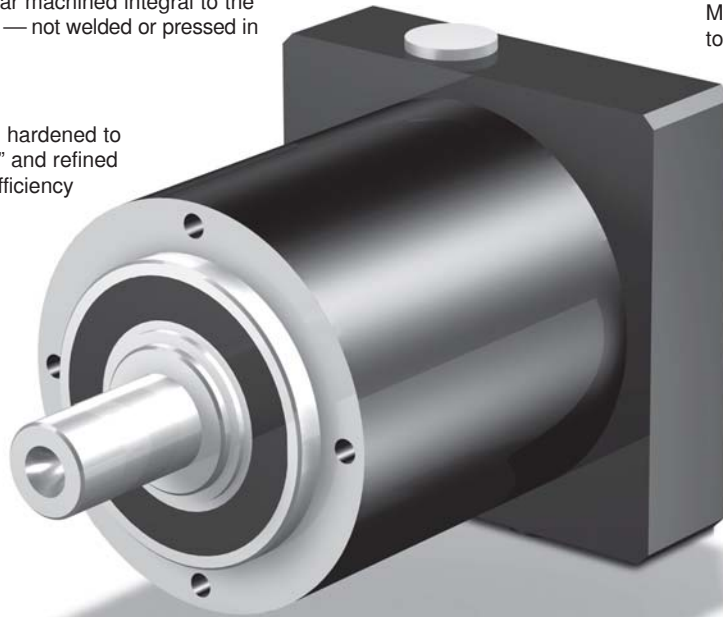

Adapter bushings fit all motor shafts — no key required

P
E

Single piece planet carrier and shaft for greater concentricity and more precise alignment



“PE” Series ServoFit® Precision Planetary Gearhead



Part No. Explanation

PE 4 0 1 SP 0050 M

Series Size Generation No. of Gear Stages Shaft Style Ratio:1 Motor Adapter

- Series **PE** Economical InLine Gearhead
- Size **4** 2, 3, **4**, 5
- Generation **0** First generation **0**, second generation 1, etc.
- No. of Gear Stages **1** 1, 2 (determined by the ratio)
- Output Style **SP** Output Shaft with Key
- Ratio **0050** Exact: 0050 = 6.0:1 (range of 5:1 up to 100:1)
- Motor Adapter **M** Motor Adapter (Motor information must be specified.)

P
E

Motor Mounting Specifications

STOBER ServoFit Gearheads will fit the motor of your choice by assembling the correct motor mounting plate between the motor and the gearhead. **When ordering a gearhead, specify the motor manufacturer and part number, provide the motor drawing with dimensions, or specify the motor mounting dimensions.** The motor plate thickness (L⁹) dimension will be determined by the motor shaft length. The minimum motor plate thickness is shown below. For a precise dimension on a specific motor, contact STOBER Technical Support.

The following dimensions are required to provide the correct motor mounting plate:

1. D⁶ Motor Shaft Diameter (If an adapter bushing is required it will be supplied with the motor plate.)
2. D⁷ Pilot Diameter
3. D⁸ Bolt Circle Diameter
4. D⁹ Bolt Diameter
5. L¹¹ Motor Shaft Length
6. L¹² Pilot Length
7. L¹⁴ Square Flange (Optional — Motor plate will typically be made to match.)

Table No. 1

Motor Plate Dims.	Planetary Size			
	PE201 PE202	PE301 PE302	PE401 PE402	PR501 PE502
D ⁶ Max.	11	14	19	24
L ⁹ Min.	18	20	30	33

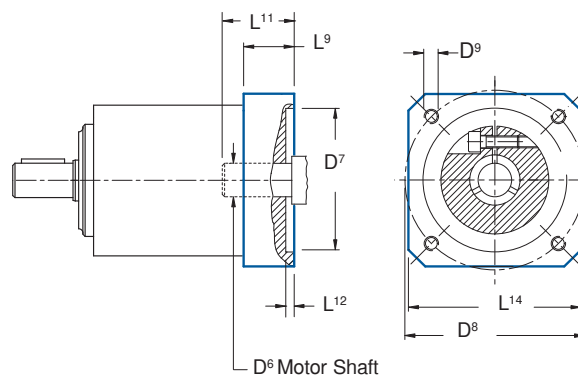



"PE" Series ServoFit® Planetary Gearhead Shaft Load

All formulas shown are based on METRIC values.

Upper case letters are permissible values. Lower case letters are for existing values.

The permissible load and tilting moment values are based on an output speed of 100 RPM. For higher speeds the following applies, where n_2 is the desired speed:

$$F_{2AX} = \frac{F_{2A}}{\sqrt[3]{\frac{n_2}{100}}} \quad F_{2RX} = \frac{F_{2R}}{\sqrt[3]{\frac{n_2}{100}}} \quad M_{2KX} = \frac{M_{2K}}{\sqrt[3]{\frac{n_2}{100}}}$$

The application input tilting moment should be determined by the following formula:

$$M_{2A} = \frac{F_{2a} \cdot y_2 + F_{2rb} \cdot (x_2 + z_2)}{1000} \leq M_{2KB}$$

- where:
- F_{2a} Axial Load at Output Shaft
 - F_{2A} Permissible Axial Load
 - F_{2r} Radial Load at Output Shaft
 - F_{2R} Permissible Radial Load
 - F_{2RB} Acceleration Permissible Radial Load
 - M_{2K} Rated Tilting Torque
 - M_{2k} Equivalent Tilting Load
 - Z_2 Distance Factor

The hours of life (L_h) of the unit can be determined by the following formula:

bearing life for duty cycle $\leq 40\%$

$L_h > 10,000$ hours if $M_{2K}/M_{2A} < 1.25$ and > 1
 $L_h > 20,000$ hours if $M_{2K}/M_{2A} > 1.25$ and > 1.5

bearing life for duty cycle $\geq 40\%$

$$L_{hA} = L_h \left(\frac{40\%}{\text{Duty Cycle}} \right)$$

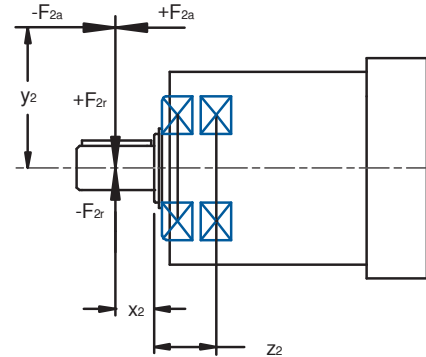

Table No. 1 "PE" Series – Permissible Load and Tilting Moments

Unit No.	Z_2		F_{2A}		F_{2R}		M_{2K}	
	mm	inches	N	lbs.	N	lbs.	Nm	in.lbs.
PE201, PE202	20	0.79	250	56	850	191	25	221
PE301, PE302	28	1.10	412	93	1,650	371	69	610
PE401, PE402	31	1.22	650	146	2,600	585	127	1,124
PE501, PE502	41	1.61	1,200	270	4,800	1,080	336	2,974





"PE" Series ServoFit® Planetary Gearhead Selection Data



Part Number (Gearhead + Input)	Exact Ratio i	Maximum Input Speed		Maximum Motor Shaft ØD ⁶ mm	Input ¹⁾ Inertia J ₁ kgcm ²	Torsional Stiffness per arcmin C ₂		Output Torque					
		Continuous RPM (n ₁)	Cyclic RPM (n ₁)			in.lbs.	Nm	Nominal ²⁾ M _{2N}		Acceleration M _{2B}		Peak ³⁾ M _{2PEAK}	
								in.lbs.	Nm	in.lbs.	Nm	in.lbs.	Nm
PE201 with Motor Mounting Plate													
PE201SP0050M	5.000	4,000	8,000	11	.063	8.9	1.0	58	6.5	133	15	248	28
PE201SP0100M	10.00	4,000	8,000	11	.063	8.9	1.0	49	5.5	106	12	248	28
PE202 with Motor Mounting Plate													
PE202SP0250M	25.00	4,000	8,000	11	.052	8.9	1.0	58	6.5	133	15	248	28
PE202SP0500M	50.00	4,000	8,000	11	.052	8.9	1.0	58	6.5	133	15	248	28
PE202SP1000M	100.0	4,000	8,000	11	.052	8.9	1.0	49	5.5	106	12	248	28
PE301 with Motor Mounting Plate ⁴⁾													
PE301SP0050M	5.000	3,700	6,000	14	.31	31	3.5	159	18	292	33	664	75
PE301SP0100M	10.00	3,700	6,000	14	.31	31	3.5	150	17	266	30	664	75
PE302 with Motor Mounting Plate ⁴⁾													
PE302SP0250M	25.00	3,700	6,000	14	.25	31	3.5	159	18	292	33	664	75
PE302SP0500M	50.00	3,700	6,000	14	.25	31	3.5	159	18	292	33	664	75
PE302SP1000M	100.0	3,700	6,000	14	.25	31	3.5	150	17	266	30	664	75
PE401 with Motor Mounting Plate													
PE401SP0050M	5.000	3,400	6,000	19	1.72	88.5	10	398	45	726	82	1,770	200
PE401SP0100M	10.00	3,400	6,000	19	1.72	88.5	10	354	40	637	72	1,770	200
PE402 with Motor Mounting Plate													
PE402SP0250M	25.00	3,400	6,000	19	1.47	88.5	10	398	45	726	82	1,770	200
PE402SP0500M	50.00	3,400	6,000	19	1.47	88.5	10	398	45	726	82	1,770	200
PE402SP1000M	100.0	3,400	6,000	19	1.47	88.5	10	354	40	637	72	1,770	200
PE501 with Motor Mounting Plate													
PE501SP0050M	5.000	2,600	5,000	24	5.50	221.3	25	1,062	120	1,859	210	4,248	480
PE501SP0100M	10.00	2,600	5,000	24	5.50	221.3	25	885	100	1,593	180	4,248	480
PE502 with Motor Mounting Plate													
PE502SP0250M	25.00	2,600	5,000	24	4.45	221.3	25	1,062	120	1,859	210	4,248	480
PE502SP0500M	50.00	2,600	5,000	24	4.45	221.3	25	1,062	120	1,859	210	4,248	480
PE502SP1000M	100.0	2,600	5,000	24	4.45	221.3	25	885	100	1,593	180	4,248	480

Part No. Example

PE401SP0050M

¹⁾ Inertia based on maximum input. For lower inertia using smaller diameter input, contact STOBER.

²⁾ Based on input speed: n₁ = 2000 RPM

For torque at higher input speeds (M_{2NX}) solve the formula, where n₁ = Actual Input Speed.
$$M_{2NX} = \frac{M_{2N}}{\sqrt[3]{\frac{n_1}{2000}}}$$

³⁾ Maximum momentary torque for emergency stops or heavy shock load. Admissible stops per life of gearhead = 1,000 stops maximum.

⁴⁾ Contact STOBER Technical Support for larger input.

See Page 182 for Options and Part Number Configuration.



"PE" Series ServoFit® Planetary Gearhead Dimensional Data



Dimension shown in millimeters (inches).

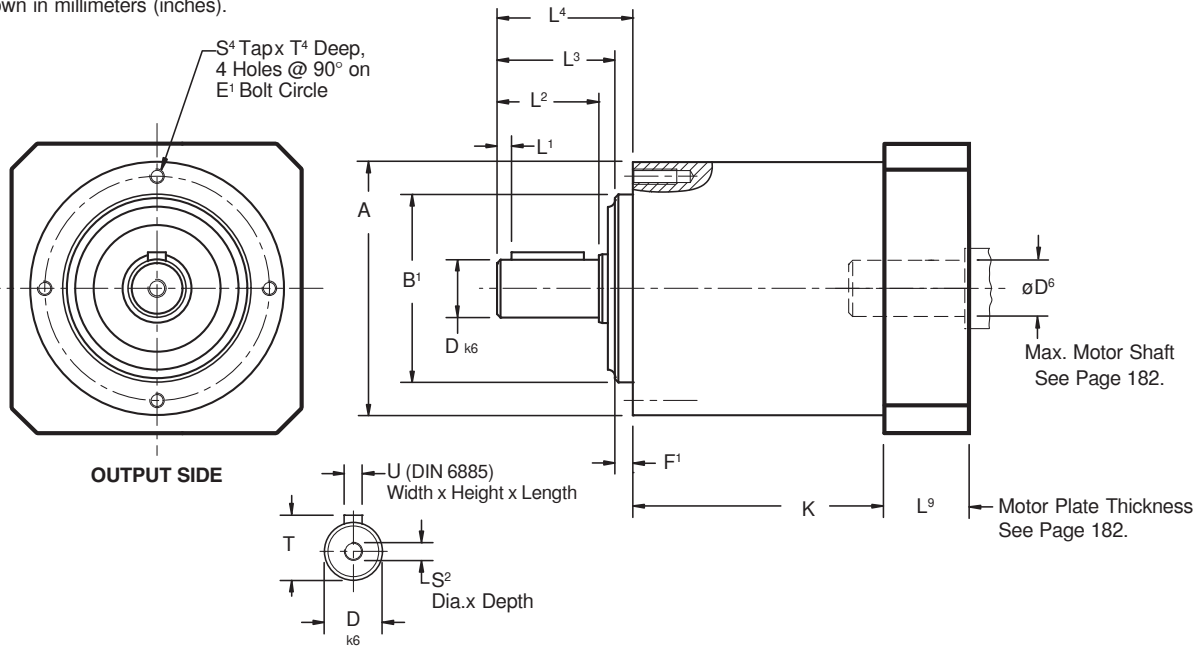

Table No. 1 "PE" Series – Planetary Gearhead Dimensions (mm)

Unit	A	B ¹	h ₆	D k ₆	E ¹	F ¹	L ¹	L ²	L ³	L ⁴	S ²	S ⁴	T	T ⁴	U	
PE201/PE202	50	35	+0.000/-0.016	12	+0.012/+0.001	44	4	2	18	20.5	24.5	M4	M4	13.5	10	A4x4x14
PE301/PE302	70	52	+0.000/-0.019	16	+0.012/+0.001	62	5	2	28	31	36	M5	M5	18	12	A5x5x25
PE401/PE402	90	68	+0.000/-0.019	22	+0.015/+0.002	80	5	3	36	41	46	M8	M6	24.5	15	A6x6x32
PE501/PE502	120	90	+0.000/-0.022	32	+0.018/+0.002	108	6	3	58	64	70	M12	M8	35	20	A10x8x50

Table No. 2

Unit	K
PE201	53
PE202	74.5
PE301	69
PE302	91.5
PE401	80
PE402	109
PE501	106.5
PE502	142

Table No. 3 NEMA Output Flange (mm/inches)

NEMA	N ¹	N ²	N ³	N ⁵	N ⁶	N ⁷	N ⁸
23	58	2.625"	1.500" +0.000/-0.001"	7	.062"	.195"	3.00"
34	83	3.875"	2.875" +0.000/-0.001"	8	.062"	.218"	4.37"
42	107	4.950"	2.186" +0.000/-0.001"	8	.062"	.281"	5.63"
56	146	5.875"	4.500" +0.000/-0.001"	15	.125"	.394"	7.87"

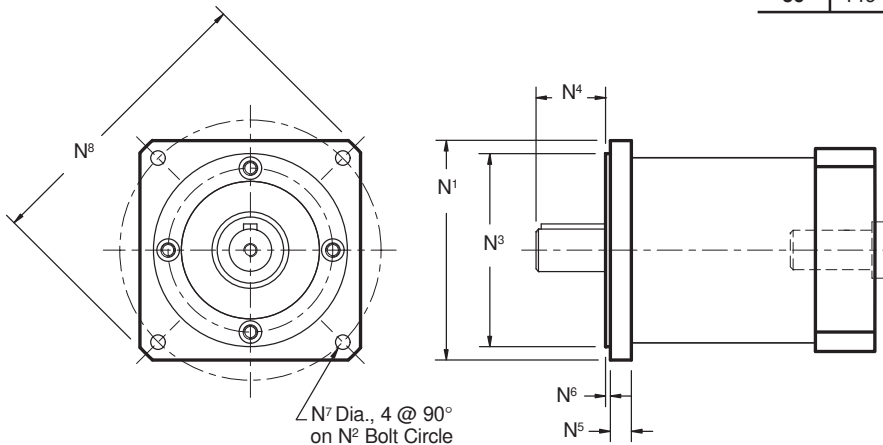

Table No. 4 N⁴ Dims. (mm)

NEMA	PE2	PE3	PE4	PE5
23	15.9	—	—	—
34	—	26.6	36.8	—
42	—	25.6	36	—
56	—	—	—	51.8

ServoFit® Modular System Output Options



Output – Solid Shaft and Hollow Bore Diameter

Table No. 1 The diameters shown **BOLD BLUE** are readily available from inventory. Contact STOBER Drives for delivery on other output sizes.

Carbon Steel				Unit Size	Stainless Steel			
Inches		Metric			Inches		Metric	
Shaft	Hollow	Shaft	Hollow		Shaft	Hollow	Shaft	Hollow
.75	—	20	—	C002	.75	—	—	—
.75, 1.00	—	25	—	C102/C103	1.00, 1.25	—	20, 25	—
1.25	—	30	—	C202/C203	1.25	—	—	—
1.25	—	30	—	C302/C303	1.25, 1.375	—	25	—
1.625	—	25, 38, 42, 40	—	C402/C403	1.625	—	—	—
1.625	—	40	—	C502/C503	1.625	—	—	—
2.125	—	50	—	C612/C613	2.125	—	—	—
2.375	—	60	—	C712/C713	2.375	—	—	—
2.875	—	70	—	C812/C813	2.875	—	—	—
3.625	—	90	—	C912/C913	—	—	—	—
1.00	.75	25	20	F102	—	—	—	—
1.25	1.00	30	25	F202/F203	—	1.00	—	—
1.375	1.25	35	30	F302/F303	—	1.25	—	—
1.625	1.4375, 1.500	40	40	F402/F403	—	1.50	—	—
2.125	2.00	50	50	F602/F603	—	—	—	—
—	—	—	—	KSS102	1.00	1.00	25	25
—	—	—	—	KSS202	1.25	1.125, 1.1875, 1.25	30	30
—	—	—	—	KSS302	1.25	1.25, 1.375	40	35
.625	.625	16	16	KL102	.625	.625	16	16
.75	.75	20	20	KL202	.75	.75	20	20
1.00	1.00	25	25	K102	1.00	1.00	25	25
1.25	1.1875, 1.25	30	30	K202/K203	1.25	1.125, 1.1875, 1.25	30	30
1.25	1.375, 1.4375	30	35	K302/K303	1.25	1.25, 1.375	40	35
1.375	1.4375, 1.500	40	40	K402/K403	1.375	1.375, 1.500	—	40
1.75	2.00	45	50	K513/K514	1.75	1.4375, 1.9375, 2.00	45	40, 50
1.75	2.00	50	50	K613/K614	1.75	1.4375, 1.9375, 2.00, 2.1875	—	40, 50, 60
2.375	2.375	60	60	K713/K714	2.375	1.9375, 2.00, 2.1875, 2.375	—	60
2.875	2.75	70	70	K813/K814	2.875	2.1875, 2.375, 2.50, 2.6875, 2.75	70	60, 70
3.625	3.25	90	70, 80, 90	K913/K914	—	2.6875, 2.9375, 3.00, 3.25, 3.4375	90	90
4.375	4.00	110	100	K1013/K1014	—	3.4375, 4.000	—	—

Output – Wobble Free Bushing

Table No. 2 Stainless Steel "WFB" Double Side and "WF" Single Side Bushings – Inches

Unit	Stock Bores Sizes																
	3/4	1	1 ³ / ₁₆	1 ¹ / ₄	1 ³ / ₈	1 ⁷ / ₁₆	1 ¹ / ₂	1 ⁵ / ₈	1 ¹¹ / ₁₆	1 ³ / ₄	1 ⁷ / ₈	1 ¹⁵ / ₁₆	2	2 ³ / ₁₆	2 ³ / ₈	2 ⁷ / ₁₆	2 ³ / ₄
KL2	x	—	—	—	—	—	—	—	—	—	—	—	—	—	—	—	—
K1	—	x	—	—	—	—	—	—	—	—	—	—	—	—	—	—	—
K2	—	x	x	—	—	—	—	—	—	—	—	—	—	—	—	—	—
K3	—	x	x	x	x	x	x	—	—	—	—	—	—	—	—	—	—
K4	—	x	x	x	x	x	x	—	—	—	—	—	—	—	—	—	—
K5	—	—	—	—	—	x	x	x	x	x	x	x	x	—	—	—	—
K6	—	—	—	—	—	x	x	x	x	x	—	x	x	x	—	—	—
K7	—	—	—	—	—	—	—	—	—	—	—	x	x	x	x	—	—
K8	—	—	—	—	—	—	—	—	—	—	—	—	—	x	x	x	x

Table No. 3 "WFB" and "WF" Stainless Steel Bushings – Metric

Double Side				Single Side			
25	30	35	40	Unit	25	30	35
x	—	—	—	K1	x	—	—
x	x	—	—	K2	—	x	—
—	x	x	—	K3	—	x	x
—	—	—	x	K4	—	—	—
—	—	—	x	K5	—	—	—
—	—	—	x	K6	—	—	—

Table No. 4 "WFBSS" Double Side Bushings – Inches

Unit	Stock Bores Sizes					
	1	1 ³ / ₁₆	1 ¹ / ₄	1 ³ / ₈	1 ⁷ / ₁₆	1 ¹ / ₂
KSS1	x	—	—	—	—	—
KSS2	x	x	x	x	x	x
KSS3	x	x	x	x	x	x



"C" Series – Concentric Helical ServoFit® Modular System

These versatile gear drives offer you performance, durability, and economy for a wide range of applications. High efficiency helical gearing keeps motor size to a minimum while running almost silently.

Performance Specifications:

- Input RPM up to 4,500 RPM
- Nominal output torque — 97 to 62,000 in.lbs. (21-7,000 Nm)
- Reducer ratios from 2:1 to 276:1
- 5 year limited warranty (2 years on bearings, seals, etc.)
- Ambient temperature — 0° C to +40° C (104° F) [Unit temperature ≤ 80° C Max.]
- Noise level — as low as 53 dB(A)
- ≥ 95.5% Efficiency
- Maintenance free
- Can be back driven



High quality helical gearing is case hardened to 58-62 Rockwell C. Precision finished for low noise and long service life. Backlash is ≤20 arc minutes

Motor plate can easily be changed to fit your choice of motors.

Double lip seals keep oil in and contaminants out. Double seals available for severe duty applications.

High tensile strength shafts with captured keys available inches, metric, or stainless.

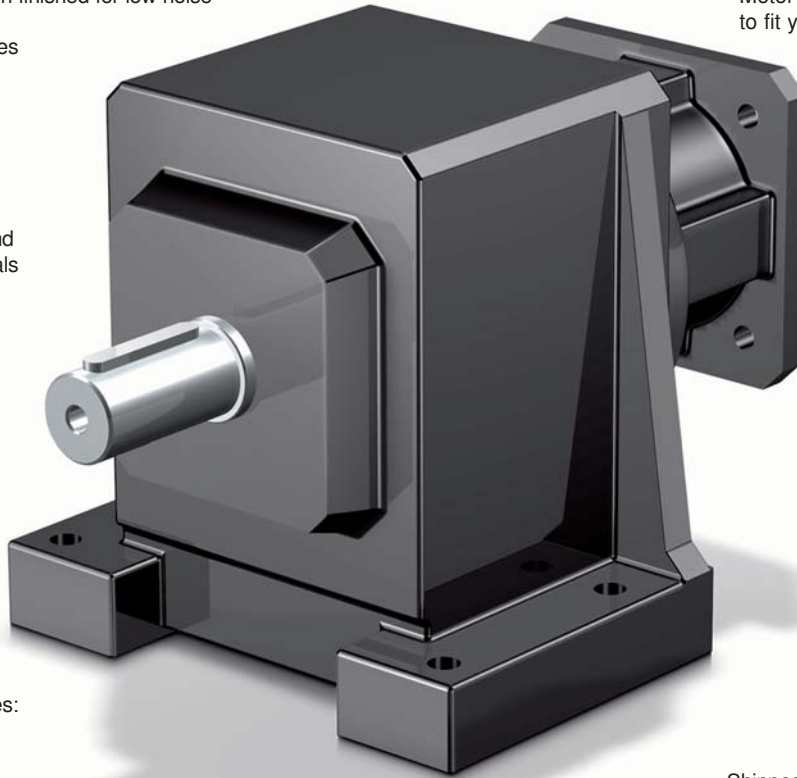

Available in four housing styles:

- N-foot mounting
- F-output flange
- Q-square output flange
- G-tapped holes

Shipped with the proper amount of oil to prevent gear damaging dry start-ups

One-piece cast iron housing. Precision machined bearing supports assure gearset alignment, prolongs bearing life, provides exceptional overhung load capacities to eliminate leakage problems common to drives with bolt-on output covers.

Also available in washdown, food duty, and beverage duty. Maximum 10 working days for custom motor plates.



“C” Series – Concentric Helical ServoFit® Modular System



Part No. Explanation

C **4** **0** **2** **N** **0135** **MT20** **B**

Series Size Generation No. of Gear Stages Housing Style Ratio:1 Motor Adapter Beverage Duty Option

Series **C** Concentric Helical (output and input in line/gears are all helical)

Size **4** C1, C2, C3, **C4**, C5, C6, C7, C8, C9

Generation **0** First generation **0**, second generation 1, etc.

No. of Gear Stages **2** 2, 3, 4 (determined by the ratio)

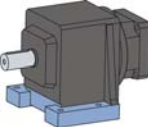
Housing Style **N** Foot Mounting 

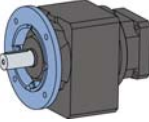
F — Round output flange 

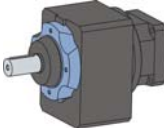
G — Tapped holes around the output 

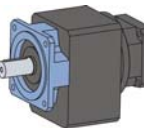
Q — Square output flange (not bolt-on type) 

Ratio **0135** Approximate: 0135 = 13.5:1 (range of 2:1 up to 276:1)

Motor Adapter **MT20** Motor adapter size from Selection Data: MT10, **MT20**, MT30, MT40
(Motor information must be specified.)

Option **B** Add when ordering Beverage Duty
F — Add when ordering Food Duty

Specify ONLY when deviating from STANDARD

Output — Inches (standard) or Metric (not available in all sizes)

Output Material — Stainless (not available in all sizes)

Paint — Black (standard), White, or Stainless

Oil — Mobilgear 600XP220 (standard), Food grade (Mobil SHC CIBUS 220) or Synthetic (Mobil SHC630)



“C” Series – Concentric Helical ServoFit® Modular System

Mounting Positions – Must be Specified

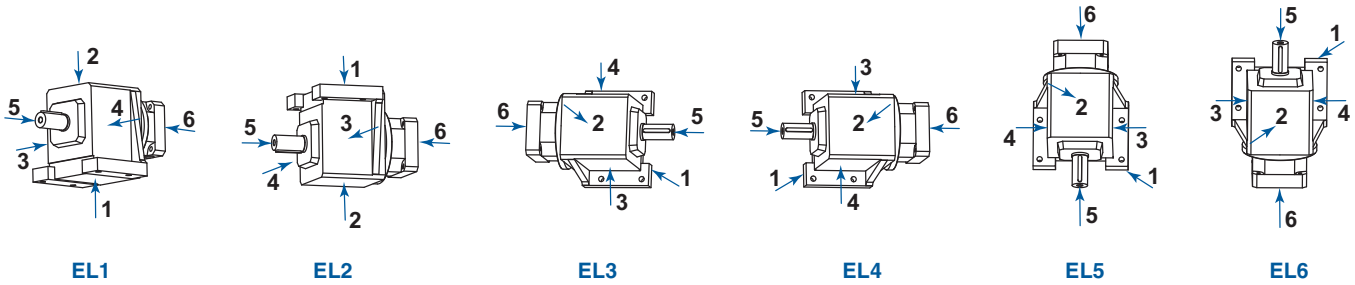

- EL1** Side 1 is the bottom side when the unit is set in a normal position. Side 1 is the down side for EL1.
- EL2** Side 2 is the top of the unit. Side 2 is the down side for EL2 . (The unit is up-side-down.)
- EL3** Side 3 is the right side when facing the input with the unit in a normal position (EL1). Side 3 is the down side for EL3.
- EL4** Side 4 is the left side when facing the input with the unit in a normal position (EL1). Side 4 is the down side for EL4.
- EL5** Side 5 is the side opposite the motor or the shaft side. Side 5 is the down side for EL5.
- EL6** Side 6 is the input or motor side. Side 6 is the down side for EL6.

DO NOT MOUNT any STOBER reducer in a position other than specified on the order.

All STOBER units are filled with the correct amount of lubrication before shipping. In order to provide the proper lubrication quantity **the mounting position must be specified at the time the unit is ordered.** Our web site: <http://www.stober.com/pages/lubrication-quantity> list the oil quantity for each size and mounting position.

Motor Mounting Specifications

STOBER ServoFit Gearheads will fit the motor of your choice by assembling the correct motor mounting plate between the motor and the gearhead. **When ordering a gearhead, specify the motor manufacturer and part number, provide the motor drawing with dimensions, or specify the motor mounting dimensions.** The motor plate thickness (L^9) dimension will be determined by the motor shaft length. The minimum motor plate thickness is shown below. For a precise dimension on a specific motor, contact STOBER Technical Support.

The following dimensions are required to provide the correct motor mounting plate:

1. D^6 Motor Shaft Diameter (If an adapter bushing is required it will be supplied with the motor plate.)
2. D^7 Pilot Diameter
3. D^8 Bolt Circle Diameter
4. D^9 Bolt Diameter
5. L^{11} Motor Shaft Length
6. L^{12} Pilot Length
7. L^{14} Square Flange (Optional — Motor plate will typically be made to match.)

Table No.1

Input Option	Shaft D^6 Max.	Motor Plate Thickness L^9 Min.
MT10	19	21
MT20	24	24
MT30	38	25
MT40	48	33
MT50	60	43

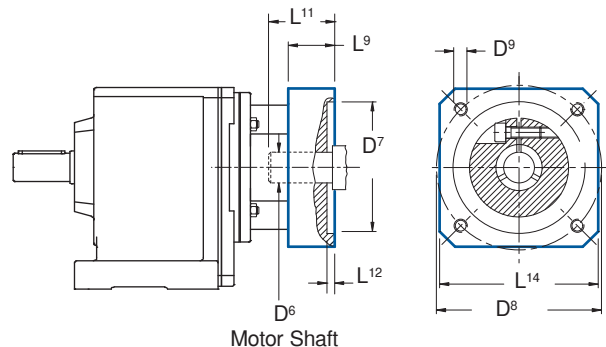

“C” Series – Concentric Helical ServoFit® Modular System



Maintenance

With STOBER reducers very little maintenance is required under normal operating conditions. Units supplied without breathers are lubricated for life and maintenance free. Breathers are provided on standard units C612 through C913, located as shown in Table 1.

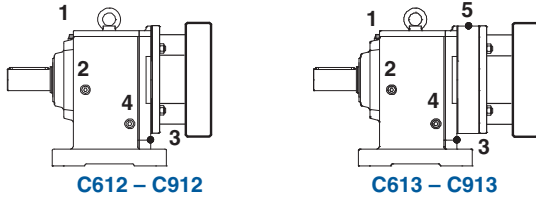

Table No. 1 Drain Plug and Vent Location

Mounting Position	1	2	2a	3	5
EL1	Vent				
EL2	Drain				
EL3		Vent			
EL4		Drain	Drain	Vent	
EL5 (C612-C912)	Drain				
EL5 (C613-C913)	Drain				Vent
EL6	Vent			Drain	

Position 2a is on the opposite side of 2.

STOBER recommends that the lubrication be changed in units supplied with breathers according to the following schedule:

Normal Operating Conditions — after 5000 Hours

Wet Operating Conditions — after 2000 Hours.

Direction of Rotation

2 Stage — C102 thru C812

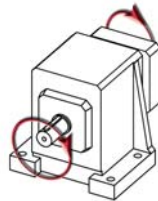

3 Stage — C103 thru C913



C

Overhung Load

Pulling forces or overhung load of pulleys, sheaves, sprockets, etc. on the reducer output shaft must not exceed the allowable limits shown in the above calculations. The overhung load shown is measured at the center of the shaft extension.

The following formula can be used to determine actual overhung load for a given drive.

METRIC

$$OHL = \frac{19,100 \times kW \times K}{D \times n}$$

where

- OHL = Newtons (N)
- kW = Transmitted Kilowatt
- D = Pitch Diameter (meters) of Sprocket, Gear, Sheave, Pulley, etc.
- n = Maximum Shaft RPM
- K = 1.00 Single Chain Drive
- 1.25 Timing Belt Drive
- 1.25 Spur, Helical Gear Drive
- 1.50 V-Belt Drive
- 2.50 Flat Belt Drive

IMPERIAL

$$OHL = \frac{126,000 \times HP \times K}{D \times RPM}$$

where

- OHL = Pounds (lbs.)
- HP = Horsepower
- D = Pitch Diameter (inches) of Sprocket, Gear, Sheave, Pulley, etc.
- n = Maximum Shaft RPM
- K = 1.00 Single Chain Drive
- 1.25 Timing Belt Drive
- 1.25 Spur, Helical Gear Drive
- 1.50 V-Belt Drive
- 2.50 Flat Belt Drive

No overhung load is encountered when an reducer is flange mounted and/or coupling connected to another unit. However, the shafts of all components must be accurately aligned and secured to prevent pre-loading of the bearings and premature bearing failure.



“C” Series – Concentric Helical ServoFit® Modular System Shaft Loads

Permissible Shaft Load and Tilting Moment

All formulas shown are based on METRIC values.

Upper case letters are permissible values. Lower case letters are for existing values.

The permissible load values given are valid with the load applied to the center of the output shaft (x₂).

The permissible load and tilting moment values are based on an output speed of 20 RPM. For higher speeds the following applies, where n₂ is the desired speed:

$$F_{2AX} = \frac{F_{2A}}{\sqrt[3]{\frac{n_2}{20}}} \quad F_{2RX} = \frac{F_{2R}}{\sqrt[3]{\frac{n_2}{20}}} \quad M_{2KX} = \frac{M_{2K}}{\sqrt[3]{\frac{n_2}{20}}}$$

The application input tilting moment should be determined by the following formula: $M_{2A} = \frac{2 \cdot F_{2a} \cdot y_2 + F_{2r} \cdot (x_2 + z_2)}{1000} \leq M_{2K}$

- F_{2a} Axial Load at Output Shaft
- F_{2A} Permissible Axial Load
- F_{2r} Radial Load at Output Shaft
- F_{2R} Permissible Radial Load
- F_{2RB} ... Acceleration Permissible Radial Load
- M_{2K} ... Rated Tilting Torque
- M_{2k} Equivalent Tilting Load
- z₂ Distance Factor

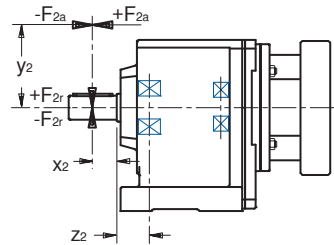

Table No. 2 Permissible Load and Tilting Moments

Unit No.	z ₂		F _{2A}		F _{2R}		M _{2K}	
	mm	inches	N	lbs.	N	lbs.	Nm	in.lbs.
C0	20	0.79	500	112	1,900	427	80	708
C1	30	1.18	850	191	3,400	765	190	1,682
C2	30	1.18	1,050	236	4,200	945	260	2,301
C3	30	1.18	1,400	315	5,650	1,271	350	3,098
C4	35	1.38	2,400	540	9,700	2,182	750	6,638
C5	42	1.65	3,000	675	11,000	2,475	900	7,965
C6	40	1.57	4,000	900	16,000	3,600	1,500	13,275
C7	45	1.77	5,500	1,237	22,000	4,950	2,400	21,240
C8	50	1.97	7,500	1,687	30,000	6,750	3,700	32,745
C9	55	2.17	9,500	2,137	37,000	8,325	5,200	46,020

Permissible Motor Tilting Torque

The permissible tilting torque of the motor attached to the gear unit is a result of the static and dynamic load “F” from the motor weight, mass acceleration, and vibration multiplied by the distance from the center of gravity “Is” of the motor.

$$M_{1k} = F \times l_s \leq M_{1K}$$

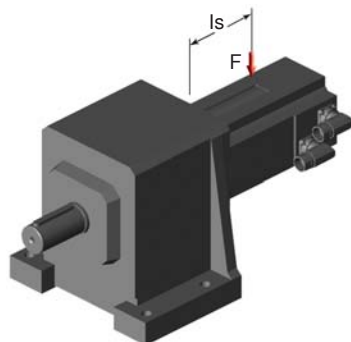

Table No. 1

M_{1K} Permissible Motor Tilting Torque

“C” Series Unit with MT	Nm	in.lbs.
MT10	25	221
MT20	60	531
MT30	125	1,106
MT40	250	2,212
MT50	600	5,310



"C" Series – Concentric Helical ServoFit® Modular System Selection Data



Part Number	Reducer Ratio i		Input RPM			Backlash arcmins $\Delta\phi$	Input Inertia J ₁ kgcm ²	Torsional Stiffness per arcmin C ₂		Output Torque					
			Maximum							Nominal ¹⁾		Acceleration		Peak ²⁾	
	Nom.	Exact	n_{1DBH}	n_{1DBV}	n_{1ZB}			$M_{2N \leq 2000 \text{ RPM}}$		M_{2B}		M_{2PEAK}			
								Continuous	Cyclic	in.lbs.	Nm	in.lbs.	Nm	in.lbs.	Nm
C002_0020 MT10	1.997	1480/741	3,500	3,000	6,000	20	1.3	7	0.8	184	21	184	21	230	26
C002_0020 MT20	1.997	1480/741	3,500	3,000	5,000	20	1.9	7	0.8	272	31	346	39	433	49
C002_0028 MT10	2.769	36/13	3,500	3,000	6,000	20	1.0	9	1.0	241	27	241	27	302	34
C002_0028 MT20	2.769	36/13	3,500	3,000	5,000	20	1.6	9	1.0	304	34	455	51	568	64
C002_0031 MT10	3.067	46/15	3,700	3,600	6,000	20	1.0	9	1.0	263	30	263	30	329	37
C002_0031 MT20	3.067	46/15	3,500	3,500	5,000	20	1.6	9	1.0	314	35	495	56	619	70
C002_0033 MT10	3.318	1702/513	3,700	3,600	6,000	20	1.0	9	1.0	284	32	284	32	356	40
C002_0033 MT20	3.318	1702/513	3,500	3,500	5,000	20	1.6	9	1.1	323	36	536	60	669	76
C002_0038 MT10	3.835	441/115	3,700	3,600	6,000	20	0.9	10	1.1	316	36	316	36	395	45
C002_0038 MT20	3.835	441/115	3,500	3,500	5,000	20	1.5	10	1.1	339	38	572	65	743	84
C002_0041 MT10	4.149	1813/437	3,700	3,600	6,000	20	0.9	10	1.1	342	39	342	39	427	48
C002_0041 MT20	4.149	1813/437	3,500	3,500	5,000	20	1.5	10	1.1	348	39	576	65	804	91
C002_0047 MT10	4.680	117/25	4,000	4,000	6,000	20	0.8	10	1.1	362	41	372	42	465	53
C002_0047 MT20	4.680	117/25	3,500	3,500	5,000	20	1.4	10	1.1	362	41	576	65	876	99
C002_0051 MT10	5.063	481/95	4,000	4,000	6,000	20	0.8	10	1.1	371	42	403	45	503	57
C002_0051 MT20	5.063	481/95	3,500	3,500	5,000	20	1.4	10	1.2	371	42	576	65	948	107
C002_0058 MT10	5.824	99/17	4,000	4,000	6,000	20	0.7	10	1.2	389	44	445	50	556	63
C002_0058 MT20	5.824	99/17	3,500	3,500	5,000	20	1.3	10	1.2	389	44	576	65	974	110
C002_0063 MT10	6.300	2035/323	4,000	4,000	6,000	20	0.7	10	1.2	399	45	481	54	601	68
C002_0063 MT20	6.300	2035/323	3,500	3,500	5,000	20	1.3	11	1.2	399	45	576	65	974	110
C002_0077 MT10	7.714	54/7	4,000	4,000	6,000	20	0.7	11	1.2	427	48	561	63	701	79
C002_0077 MT20	7.714	54/7	3,500	3,500	5,000	20	1.3	11	1.2	427	48	561	63	701	79
C002_0082 MT10	8.235	667/81	3,700	3,600	6,000	16	0.9	14	1.5	516	58	638	72	882	100
C002_0082 MT20	8.235	667/81	3,500	3,500	5,000	16	1.5	14	1.5	516	58	638	72	1,063	120
C002_0092 MT10	9.228	1495/162	3,700	3,600	6,000	16	0.9	14	1.5	531	60	576	65	989	112
C002_0092 MT20	9.228	1495/162	3,500	3,500	5,000	16	1.5	14	1.6	531	60	576	65	1,063	120
C002_0105 MT10	10.30	1421/138	3,700	3,600	6,000	16	0.8	14	1.6	531	60	638	72	1,060	120
C002_0105 MT20	10.30	1421/138	3,500	3,500	5,000	16	1.4	14	1.6	531	60	638	72	1,063	120
C002_0115 MT10	11.54	3185/276	3,700	3,600	6,000	16	0.8	14	1.6	531	60	576	65	1,063	120
C002_0115 MT20	11.54	3185/276	3,500	3,500	5,000	16	1.4	14	1.6	531	60	576	65	1,063	120
C002_0125 MT10	12.57	377/30	4,000	4,000	6,000	16	0.8	14	1.6	531	60	638	72	1,063	120
C002_0125 MT20	12.57	377/30	3,500	3,500	5,000	16	1.4	14	1.6	531	60	638	72	1,063	120
C002_0140 MT10	14.08	169/12	4,000	4,000	6,000	16	0.8	14	1.6	531	60	576	65	1,063	120
C002_0140 MT20	14.08	169/12	3,500	3,500	5,000	16	1.4	14	1.6	531	60	576	65	1,063	120
C002_0155 MT10	15.64	1595/102	4,000	4,000	6,000	16	0.7	14	1.6	531	60	638	72	1,063	120
C002_0155 MT20	15.64	1595/102	3,500	3,500	5,000	16	1.3	14	1.6	531	60	638	72	1,063	120
C002_0175 MT10	17.53	3575/204	4,000	4,000	6,000	16	0.7	14	1.6	531	60	576	65	1,063	120
C002_0175 MT20	17.53	3575/204	3,500	3,500	5,000	16	1.3	14	1.6	531	60	576	65	1,063	120
C002_0210 MT10	20.71	145/7	4,000	4,000	6,000	16	0.7	14	1.6	531	60	638	72	1,063	120
C002_0210 MT20	20.71	145/7	3,500	3,500	5,000	16	1.3	14	1.6	531	60	638	72	1,063	120
C002_0230 MT10	23.21	325/14	4,000	4,000	6,000	16	0.7	14	1.6	531	60	576	65	1,063	120
C002_0230 MT20	23.21	325/14	3,500	3,500	5,000	16	1.3	14	1.6	531	60	576	65	1,063	120
C002_0250 MT10	24.97	899/36	4,000	4,000	6,000	16	0.7	14	1.6	531	60	638	72	1,063	120
C002_0250 MT20	24.97	899/36	3,500	3,500	5,000	16	1.3	14	1.6	531	60	638	72	1,063	120
C002_0280 MT10	27.99	2015/72	4,000	4,000	6,000	16	0.7	14	1.6	531	60	576	65	1,063	120
C002_0280 MT20	27.99	2015/72	3,500	3,500	5,000	16	1.3	14	1.6	531	60	576	65	1,063	120
C002_0310 MT10	31.26	2813/90	4,000	4,000	6,000	16	0.6	14	1.6	531	60	638	72	1,063	120
C002_0310 MT20	31.26	2813/90	3,500	3,500	5,000	16	1.2	14	1.6	531	60	638	72	1,063	120

C002 with MT TriAdapt® Motor Adapter *Continued Next Page*

Noise Level ≤ 55 dB(A)³⁾

C

Maximum Motor Shaft

Adapter	Diameter	Adapter	Diameter
MT10	19	MT40	48
MT20	24	MT50	60
MT30	38		

¹⁾ Maximum torque for continuous input RPM - horizontal output position.
²⁾ Maximum momentary torque for emergency stops or heavy shock load.
 Admissible stops per life of reducer = 1,000 stops maximum.
³⁾ dB(A) Measured at 1 meter distance with 3000 RPM input.



"C" Series – Concentric Helical ServoFit® Modular System Selection Data



Part Number	Reducer Ratio i		Input RPM			Backlash arcmins $\Delta\phi$	Input Inertia J ₁ kgcm ²	Torsional Stiffness per arcmin C ₂		Output Torque					
			Maximum							Nominal ¹⁾		Acceleration		Peak ²⁾	
	Nom.		Exact		Continuous			Cyclic	M _{2N} ≤ 2000 RPM		M _{2B}		M _{2PEAK}		
	n _{1DBH}	n _{1DBV}	n _{1ZB}		in.lbs.			Nm	in.lbs.	Nm	in.lbs.	Nm	in.lbs.	Nm	

C002 with MT TriAdapt® Motor Adapter *Continued*

Noise Level ≤ 55 dB(A)³⁾

C002_0350 MT10	35.03	1261/36	4,000	4,000	6,000	16	0.6	14	1.6	531	60	576	65	1,063	120
C002_0350 MT20	35.03	1261/36	3,500	3,500	5,000	16	1.2	14	1.6	531	60	576	65	1,063	120
C002_0420 MT10	41.77	3509/84	4,000	4,000	6,000	16	0.6	14	1.6	531	60	638	72	1,063	120
C002_0470 MT10	46.82	7865/168	4,000	4,000	6,000	16	0.6	14	1.6	531	60	576	65	1,063	120
C002_0500 MT10	49.94	899/18	4,000	4,000	6,000	16	0.6	14	1.6	531	60	638	72	1,048	118
C002_0560 MT10	55.97	2015/36	4,000	4,000	6,000	16	0.6	14	1.6	531	60	576	65	1,063	120
C002_0620 MT10	62.35	1247/20	4,000	4,000	6,000	16	0.6	14	1.6	531	60	638	72	1,063	120
C002_0700 MT10	69.88	559/8	4,000	4,000	6,000	16	0.6	14	1.6	531	60	576	65	1,063	120

C102 with MT TriAdapt® Motor Adapter *Continued Next Page*

Noise Level ≤ 55 dB(A)³⁾

C102_0020 MT10	2.018	1128/559	3,100	2,600	5,000	18	2.5	12	1.3	195	22	195	22	243	27
C102_0020 MT20	2.018	1128/559	3,100	2,600	5,000	18	3.1	12	1.4	547	62	763	86	1,076	121
C102_0020 MT30	2.018	1128/559	3,100	2,600	4,000	18	7.9	16	1.8	547	62	861	97	1,076	121
C102_0022 MT10	2.177	468/215	3,100	2,600	5,000	18	2.4	13	1.4	210	24	210	24	263	30
C102_0022 MT20	2.177	468/215	3,100	2,600	5,000	18	3.0	13	1.5	561	63	823	93	1,161	131
C102_0022 MT30	2.177	468/215	3,100	2,600	4,000	18	7.8	17	1.9	561	63	929	105	1,161	131
C102_0024 MT20	2.394	2303/962	3,100	2,600	5,000	18	2.7	15	1.7	579	65	905	102	1,260	142
C102_0024 MT30	2.394	2303/962	3,100	2,600	4,000	18	7.5	18	2.0	579	65	978	110	1,260	142
C102_0026 MT20	2.582	1911/740	3,100	2,600	5,000	18	2.7	16	1.8	593	67	976	110	1,359	153
C102_0026 MT30	2.582	1911/740	3,100	2,600	4,000	18	7.5	19	2.1	593	67	1,003	113	1,359	153
C102_0031 MT10	3.091	2491/806	3,600	3,100	6,000	18	1.6	17	2.0	282	32	282	32	352	40
C102_0031 MT20	3.091	2491/806	3,500	3,100	5,000	18	2.2	18	2.0	630	71	1,065	120	1,556	176
C102_0031 MT30	3.091	2491/806	3,500	3,100	4,000	18	7.0	21	2.4	630	71	1,065	120	1,556	176
C102_0033 MT10	3.334	2067/620	3,600	3,100	6,000	18	1.6	18	2.1	304	34	304	34	380	43
C102_0033 MT20	3.334	2067/620	3,500	3,100	5,000	18	2.2	19	2.1	646	73	1,092	123	1,678	189
C102_0033 MT30	3.334	2067/620	3,500	3,100	4,000	18	7.0	22	2.4	646	73	1,092	123	1,678	189
C102_0039 MT10	3.883	1363/351	3,600	3,100	6,000	18	1.3	20	2.3	342	39	342	39	427	48
C102_0039 MT20	3.883	1363/351	3,500	3,100	5,000	18	1.9	21	2.3	680	77	1,149	130	1,888	213
C102_0039 MT30	3.883	1363/351	3,500	3,100	4,000	18	6.7	23	2.6	680	77	1,149	130	1,888	213
C102_0042 MT10	4.189	377/90	3,600	3,100	6,000	18	1.3	21	2.4	369	42	369	42	461	52
C102_0042 MT20	4.189	377/90	3,500	3,100	5,000	18	1.9	22	2.4	697	79	1,152	130	1,949	220
C102_0042 MT30	4.189	377/90	3,500	3,100	4,000	18	6.7	24	2.7	697	79	1,152	130	1,949	220
C102_0047 MT10	4.658	3149/676	3,800	3,500	6,000	18	1.1	22	2.5	396	45	396	45	494	56
C102_0047 MT20	4.658	3149/676	3,500	3,500	5,000	18	1.7	22	2.5	722	82	1,152	130	1,949	220
C102_0047 MT30	4.658	3149/676	3,500	3,500	4,000	18	6.5	24	2.7	722	82	1,152	130	1,949	220
C102_0050 MT10	5.025	201/40	3,800	3,500	6,000	18	1.1	23	2.6	427	48	427	48	533	60
C102_0050 MT20	5.025	201/40	3,500	3,500	5,000	18	1.7	23	2.6	741	84	1,152	130	1,949	220
C102_0050 MT30	5.025	201/40	3,500	3,500	4,000	18	6.5	25	2.8	741	84	1,152	130	1,949	220
C102_0059 MT10	5.875	47/8	3,800	3,500	6,000	18	1.0	24	2.7	480	54	480	54	600	68
C102_0059 MT20	5.875	47/8	3,500	3,500	5,000	18	1.6	24	2.7	781	88	1,152	130	1,949	220
C102_0059 MT30	5.875	47/8	3,500	3,500	4,000	18	6.4	25	2.9	781	88	1,152	130	1,949	220
C102_0063 MT10	6.338	507/80	3,800	3,500	6,000	18	1.0	24	2.7	517	58	517	58	647	73
C102_0063 MT20	6.338	507/80	3,500	3,500	5,000	18	1.6	25	2.8	801	90	1,152	130	1,949	220
C102_0063 MT30	6.338	507/80	3,500	3,500	4,000	18	6.4	26	2.9	801	90	1,152	130	1,949	220
C102_0078 MT10	7.796	3243/416	4,000	3,900	6,000	18	0.8	25	2.9	602	68	602	68	752	85
C102_0078 MT20	7.796	3243/416	3,500	3,500	5,000	18	1.4	26	2.9	858	97	1,152	130	1,949	220
C102_0078 MT30	7.796	3243/416	3,500	3,500	4,000	18	6.2	26	3.0	858	97	1,152	130	1,949	220
C102_0083 MT10	8.263	1537/186	3,600	3,100	6,000	15	1.3	32	3.6	753	85	753	85	941	106
C102_0083 MT20	8.263	1537/186	3,500	3,100	5,000	15	1.9	32	3.6	1,033	117	1,222	138	2,126	240
C102_0083 MT30	8.263	1537/186	3,500	3,100	4,000	15	6.7	33	3.7	1,033	117	1,222	138	2,126	240

See Page 188 for Options and Part Number Configuration.



"C" Series – Concentric Helical ServoFit® Modular System Selection Data



Part Number	Reducer Ratio i		Input RPM			Backlash arcmins $\Delta\phi$	Input Inertia J ₁ kgcm ²	Torsional Stiffness per arcmin C ₂		Output Torque					
			Maximum							Nominal ¹⁾		Acceleration		Peak ²⁾	
	Nom.	Exact	n_{1DBH}	n_{1DBV}	n_{1ZB}			$M_{2N \leq 2000 \text{ RPM}}$		M_{2B}		M_{2PEAK}			
								Continuous	Cyclic	in.lbs.	Nm	in.lbs.	Nm	in.lbs.	Nm
C102 with MT TriAdapt® Motor Adapter <i>Continued</i> Noise Level $\leq 55 \text{ dB(A)}^{(3)}$															
C102_0093 MT10	9.326	3180/341	3,600	3,100	6,000	15	1.3	32	3.6	850	96	850	96	1,062	120
C102_0093 MT20	9.326	3180/341	3,500	3,100	5,000	15	1.9	32	3.7	1,063	120	1,222	138	2,126	240
C102_0093 MT30	9.326	3180/341	3,500	3,100	4,000	15	6.7	33	3.8	1,063	120	1,222	138	2,126	240
C102_0105 MT10	10.38	841/81	3,600	3,100	6,000	15	1.1	33	3.7	914	103	914	103	1,142	129
C102_0105 MT20	10.38	841/81	3,500	3,100	5,000	15	1.7	33	3.7	1,063	120	1,222	138	2,126	240
C102_0105 MT30	10.38	841/81	3,500	3,100	4,000	15	6.5	34	3.8	1,063	120	1,222	138	2,126	240
C102_0115 MT10	11.72	1160/99	3,600	3,100	6,000	15	1.1	33	3.7	1,031	116	1,031	116	1,289	146
C102_0115 MT20	11.72	1160/99	3,500	3,100	5,000	15	1.7	33	3.8	1,063	120	1,222	138	2,126	240
C102_0115 MT30	11.72	1160/99	3,500	3,100	4,000	15	6.5	34	3.8	1,063	120	1,222	138	2,126	240
C102_0125 MT10	12.46	1943/156	3,800	3,500	6,000	15	1.0	33	3.8	1,058	119	1,058	119	1,322	149
C102_0125 MT20	12.46	1943/156	3,500	3,500	5,000	15	1.6	33	3.8	1,063	120	1,222	138	2,126	240
C102_0125 MT30	12.46	1943/156	3,500	3,500	4,000	15	6.4	34	3.8	1,063	120	1,222	138	2,126	240
C102_0140 MT10	14.06	2010/143	3,800	3,500	6,000	15	1.0	34	3.8	1,063	120	1,194	135	1,492	168
C102_0140 MT20	14.06	2010/143	3,500	3,500	5,000	15	1.6	34	3.8	1,063	120	1,222	138	2,126	240
C102_0140 MT30	14.06	2010/143	3,500	3,500	4,000	15	6.4	34	3.9	1,063	120	1,222	138	2,126	240
C102_0155 MT10	15.71	377/24	3,800	3,500	6,000	15	0.9	34	3.8	1,063	120	1,222	138	1,603	181
C102_0155 MT20	15.71	377/24	3,500	3,500	5,000	15	1.5	34	3.8	1,063	120	1,222	138	2,126	240
C102_0155 MT30	15.71	377/24	3,500	3,500	4,000	15	6.3	34	3.9	1,063	120	1,222	138	2,126	240
C102_0175 MT10	17.73	195/11	3,800	3,500	6,000	15	0.9	34	3.8	1,063	120	1,222	138	1,809	204
C102_0175 MT20	17.73	195/11	3,500	3,500	5,000	15	1.5	34	3.9	1,063	120	1,222	138	2,126	240
C102_0175 MT30	17.73	195/11	3,500	3,500	4,000	15	6.3	34	3.9	1,063	120	1,222	138	2,126	240
C102_0210 MT10	20.84	667/32	4,000	3,900	6,000	15	0.8	34	3.9	1,063	120	1,222	138	2,012	227
C102_0210 MT20	20.84	667/32	3,500	3,500	5,000	15	1.4	34	3.9	1,063	120	1,222	138	2,126	240
C102_0210 MT30	20.84	667/32	3,500	3,500	4,000	15	6.2	34	3.9	1,063	120	1,222	138	2,126	240
C102_0240 MT10	23.52	1035/44	4,000	3,900	6,000	15	0.8	34	3.9	1,063	120	1,222	138	2,126	240
C102_0240 MT20	23.52	1035/44	3,500	3,500	5,000	15	1.4	34	3.9	1,063	120	1,222	138	2,126	240
C102_0240 MT30	23.52	1035/44	3,500	3,500	4,000	15	6.2	35	3.9	1,063	120	1,222	138	2,126	240
C102_0250 MT10	25.13	377/15	4,000	3,900	6,000	15	0.8	34	3.9	1,063	120	1,222	138	2,126	240
C102_0250 MT20	25.13	377/15	3,500	3,500	5,000	15	1.4	34	3.9	1,063	120	1,222	138	2,126	240
C102_0250 MT30	25.13	377/15	3,500	3,500	4,000	15	6.2	35	3.9	1,063	120	1,222	138	2,126	240
C102_0280 MT10	28.36	312/11	4,000	3,900	6,000	15	0.8	35	3.9	1,063	120	1,222	138	2,126	240
C102_0280 MT20	28.36	312/11	3,500	3,500	5,000	15	1.4	35	3.9	1,063	120	1,222	138	2,126	240
C102_0280 MT30	28.36	312/11	3,500	3,500	4,000	15	6.2	35	3.9	1,063	120	1,222	138	2,126	240
C102_0310 MT10	31.07	435/14	4,000	3,900	6,000	15	0.7	35	3.9	1,063	120	1,222	138	2,126	240
C102_0310 MT20	31.07	435/14	3,500	3,500	5,000	15	1.3	35	3.9	1,063	120	1,222	138	2,126	240
C102_0310 MT30	31.07	435/14	3,500	3,500	4,000	15	6.1	35	3.9	1,063	120	1,222	138	2,126	240
C102_0350 MT10	35.07	2700/77	4,000	3,900	6,000	15	0.7	35	3.9	1,063	120	1,222	138	2,126	240
C102_0350 MT20	35.07	2700/77	3,500	3,500	5,000	15	1.3	35	3.9	1,063	120	1,222	138	2,126	240
C102_0350 MT30	35.07	2700/77	3,500	3,500	4,000	15	6.1	35	3.9	1,063	120	1,222	138	2,126	240
C102_0420 MT10	41.57	1247/30	4,000	3,900	6,000	15	0.7	35	3.9	1,063	120	1,222	138	2,126	240
C102_0420 MT20	41.57	1247/30	3,500	3,500	5,000	15	1.3	35	3.9	1,063	120	1,222	138	2,126	240
C102_0470 MT10	46.91	516/11	4,000	3,900	6,000	15	0.7	35	3.9	1,063	120	1,222	138	2,126	240
C102_0470 MT20	46.91	516/11	3,500	3,500	5,000	15	1.3	35	3.9	1,063	120	1,222	138	2,126	240
C102_0500 MT10	49.94	899/18	4,000	3,900	6,000	15	0.6	35	3.9	1,063	120	1,222	138	2,089	236
C102_0560 MT10	56.36	620/11	4,000	3,900	6,000	15	0.6	35	3.9	1,063	120	1,222	138	2,126	240
C102_0620 MT10	62.43	4495/72	4,000	3,900	6,000	15	0.6	35	3.9	1,054	119	1,222	138	2,108	238
C102_0700 MT10	70.46	775/11	4,000	3,900	6,000	15	0.6	35	3.9	1,063	120	1,222	138	2,126	240

Maximum Motor Shaft			
Adapter	Diameter	Adapter	Diameter
MT10	19	MT40	48
MT20	24	MT50	60
MT30	38		

¹⁾ Maximum torque for continuous input RPM - horizontal output position.
²⁾ Maximum momentary torque for emergency stops or heavy shock load. Admissible stops per life of reducer = 1,000 stops maximum.
³⁾ dB(A) Measured at 1 meter distance with 3000 RPM input.



"C" Series – Concentric Helical ServoFit® Modular System Selection Data



Part Number	Reducer Ratio i		Input RPM			Backlash arcmins $\Delta\phi$	Input Inertia J ₁ kgcm ²	Torsional Stiffness per arcmin C ₂		Output Torque					
			Maximum							Nominal ¹⁾		Acceleration		Peak ²⁾	
	Nom.	Exact	n _{1DBH}	n _{1DBV}	n _{1ZB}			M _{2N} ≤ 2000 RPM		M _{2B}		M _{2PEAK}			
								Continuous	Cyclic	in.lbs.	Nm	in.lbs.	Nm	in.lbs.	Nm
C103 with MT TriAdapt® Motor Adapter Noise Level ≤ 55 dB(A)³⁾															
C103_0820 MT10	81.64	31349/384	4,000	3,900	6,000	15	0.7	35	3.9	1,063	120	1,222	138	2,126	240
C103_0920 MT10	92.13	16215/176	4,000	3,900	6,000	15	0.7	35	3.9	1,063	120	1,222	138	2,126	240
C103_1110 MT10	111.1	1222/11	4,000	3,900	6,000	15	0.7	35	3.9	1,063	120	1,222	138	2,126	240
C103_1370 MT10	137.3	10575/77	4,000	3,900	6,000	15	0.7	35	3.9	1,063	120	1,222	138	2,126	240
C103_1840 MT10	183.7	2021/11	4,000	3,900	6,000	15	0.6	35	3.9	1,063	120	1,222	138	2,126	240
C103_2210 MT10	220.8	7285/33	4,000	3,900	6,000	15	0.6	35	3.9	1,063	120	1,222	138	2,126	240
C103_2760 MT10	275.9	36425/132	4,000	3,900	6,000	15	0.6	35	3.9	1,063	120	1,222	138	2,126	240
C202 with MT TriAdapt® Motor Adapter Noise Level ≤ 53 dB(A)³⁾ Continued Next Page															
C202_0020 MT20	2.009	432/215	3,000	2,600	4,500	17	5.1	15	1.7	690	78	760	86	1,114	126
C202_0020 MT30	2.009	432/215	3,000	2,600	4,000	17	9.9	21	2.4	834	94	1,408	159	2,874	324
C202_0022 MT20	2.184	2160/989	3,000	2,600	4,500	17	4.9	17	2.0	751	85	826	93	1,211	137
C202_0022 MT30	2.184	2160/989	3,000	2,600	4,000	17	9.7	23	2.6	857	97	1,448	163	3,100	350
C202_0025 MT20	2.475	99/40	3,000	2,600	4,500	17	4.1	20	2.3	851	96	936	106	1,328	150
C202_0025 MT30	2.475	99/40	3,000	2,600	4,000	17	8.9	27	3.0	894	101	1,062	120	1,328	150
C202_0027 MT20	2.690	495/184	3,000	2,600	4,500	17	4.0	23	2.5	919	104	1,017	115	1,443	163
C202_0027 MT30	2.690	495/184	3,000	2,600	4,000	17	8.8	29	3.3	919	104	1,155	130	1,443	163
C202_0031 MT20	3.103	90/29	3,500	3,100	5,000	17	3.3	26	3.0	964	109	1,173	132	1,618	183
C202_0031 MT30	3.103	90/29	3,500	3,100	4,000	17	8.1	33	3.7	964	109	1,295	146	1,618	183
C202_0034 MT20	3.373	2250/667	3,500	3,100	5,000	17	3.2	29	3.2	991	112	1,275	144	1,759	199
C202_0034 MT30	3.373	2250/667	3,500	3,100	4,000	17	8.0	35	3.9	991	112	1,407	159	1,759	199
C202_0039 MT20	3.888	486/125	3,500	3,100	5,000	17	2.7	32	3.6	1,039	117	1,470	166	1,954	221
C202_0039 MT30	3.888	486/125	3,500	3,100	4,000	17	7.5	38	4.3	1,039	117	1,563	176	1,954	221
C202_0042 MT20	4.226	486/115	3,500	3,100	5,000	17	2.6	34	3.9	1,068	121	1,598	180	2,124	240
C202_0042 MT30	4.226	486/115	3,500	3,100	4,000	17	7.4	40	4.5	1,068	121	1,699	192	2,124	240
C202_0047 MT20	4.667	14/3	3,500	3,500	5,000	17	2.3	37	4.1	1,104	125	1,764	199	2,261	255
C202_0047 MT30	4.667	14/3	3,500	3,500	4,000	17	7.1	42	4.7	1,104	125	1,772	200	2,261	255
C202_0051 MT20	5.072	350/69	3,500	3,500	5,000	17	2.3	39	4.4	1,135	128	1,772	200	2,457	277
C202_0051 MT30	5.072	350/69	3,500	3,500	4,000	17	7.1	43	4.9	1,135	128	1,772	200	2,457	277
C202_0058 MT10	5.791	666/115	3,700	3,500	5,500	17	1.4	40	4.5	488	55	488	55	610	69
C202_0058 MT20	5.791	666/115	3,500	3,500	5,000	17	2.0	41	4.7	1,186	134	1,772	200	2,696	304
C202_0058 MT30	5.791	666/115	3,500	3,500	4,000	17	6.8	45	5.1	1,186	134	1,772	200	2,696	304
C202_0063 MT10	6.295	3330/529	3,700	3,500	5,500	17	1.4	42	4.7	530	60	530	60	663	75
C202_0063 MT20	6.295	3330/529	3,500	3,500	5,000	17	2.0	43	4.8	1,220	138	1,772	200	2,930	331
C202_0063 MT30	6.295	3330/529	3,500	3,500	4,000	17	6.8	46	5.2	1,220	138	1,772	200	2,930	331
C202_0078 MT10	7.800	39/5	4,000	3,900	6,000	17	1.1	45	5.1	618	70	618	70	772	87
C202_0078 MT20	7.800	39/5	3,500	3,500	5,000	17	1.7	46	5.2	1,310	148	1,772	200	3,100	350
C202_0078 MT30	7.800	39/5	3,500	3,500	4,000	17	6.5	48	5.5	1,310	148	1,772	200	3,100	350
C202_0082 MT20	8.190	475/58	3,500	3,100	5,000	14	2.7	61	6.9	1,692	191	2,037	230	3,543	400
C202_0082 MT30	8.190	475/58	3,500	3,100	4,000	14	7.5	65	7.4	1,692	191	2,037	230	3,543	400
C202_0094 MT20	9.387	2450/261	3,500	3,100	5,000	14	2.7	64	7.2	1,771	200	2,037	230	3,543	400
C202_0094 MT30	9.387	2450/261	3,500	3,100	4,000	14	7.5	67	7.6	1,771	200	2,037	230	3,543	400
C202_0105 MT20	10.26	513/50	3,500	3,100	5,000	14	2.3	65	7.3	1,772	200	2,037	230	3,543	400
C202_0105 MT30	10.26	513/50	3,500	3,100	4,000	14	7.1	68	7.7	1,772	200	2,037	230	3,543	400
C202_0120 MT20	11.76	294/25	3,500	3,100	5,000	14	2.3	67	7.5	1,772	200	2,037	230	3,543	400
C202_0120 MT30	11.76	294/25	3,500	3,100	4,000	14	7.1	69	7.8	1,772	200	2,037	230	3,543	400
C202_0125 MT20	12.32	665/54	3,500	3,500	5,000	14	2.1	67	7.6	1,772	200	2,037	230	3,543	400
C202_0125 MT30	12.32	665/54	3,500	3,500	4,000	14	6.9	70	7.9	1,772	200	2,037	230	3,543	400

See Page 188 for Options and Part Number Configuration.



"C" Series – Concentric Helical ServoFit® Modular System Selection Data



Part Number	Reducer Ratio i		Input RPM			Backlash arcmins $\Delta\phi$	Input Inertia J ₁ kgcm ²	Torsional Stiffness per arcmin C ₂		Output Torque					
			Maximum							Nominal ¹⁾		Acceleration		Peak ²⁾	
	Nom.		Exact		Continuous			Cyclic	M _{2N} ≤ 2000 RPM		M _{2B}		M _{2PEAK}		
	n _{1DBH}	n _{1DBV}	n _{1ZB}		in.lbs.			Nm	in.lbs.	Nm	in.lbs.	Nm	in.lbs.	Nm	

C202 with MT TriAdapt® Motor Adapter *Continued*

Noise Level ≤ 53 dB(A)³⁾

C202_0140 MT20	14.12	3430/243	3,500	3,500	5,000	14	2.0	69	7.8	1,772	200	2,037	230	3,543	400
C202_0140 MT30	14.12	3430/243	3,500	3,500	4,000	14	6.8	70	8.0	1,772	200	2,037	230	3,543	400
C202_0155 MT10	15.28	703/46	3,700	3,500	5,000	14	1.2	69	7.8	1,287	145	1,287	145	1,609	182
C202_0155 MT20	15.28	703/46	3,500	3,500	5,000	14	1.8	69	7.8	1,772	200	2,037	230	3,543	400
C202_0155 MT30	15.28	703/46	3,500	3,500	4,000	14	6.6	71	8.0	1,772	200	2,037	230	3,543	400
C202_0175 MT10	17.52	3626/207	3,700	3,500	5,500	14	1.2	70	7.9	1,476	167	1,476	167	1,844	208
C202_0175 MT20	17.52	3626/207	3,500	3,500	5,000	14	1.8	70	7.9	1,772	200	2,037	230	3,543	400
C202_0175 MT30	17.52	3626/207	3,500	3,500	4,000	14	6.6	71	8.1	1,772	200	2,037	230	3,543	400
C202_0210 MT10	20.58	247/12	4,000	3,900	6,000	14	1.0	71	8.0	1,631	184	1,631	184	2,038	230
C202_0210 MT20	20.58	247/12	3,500	3,500	5,000	14	1.6	71	8.0	1,772	200	2,037	230	3,543	400
C202_0210 MT30	20.58	247/12	3,500	3,500	4,000	14	6.4	72	8.1	1,772	200	2,037	230	3,543	400
C202_0240 MT10	23.59	637/27	4,000	3,900	6,000	14	1.0	71	8.1	1,772	200	1,869	211	2,337	264
C202_0240 MT20	23.59	637/27	3,500	3,500	5,000	14	1.6	72	8.1	1,772	200	2,037	230	3,543	400
C202_0240 MT30	23.59	637/27	3,500	3,500	4,000	14	6.4	72	8.2	1,772	200	2,037	230	3,543	400
C202_0250 MT10	24.64	1577/64	4,000	3,900	6,000	14	0.9	72	8.1	1,772	200	1,889	213	2,362	267
C202_0250 MT20	24.64	1577/64	3,500	3,500	5,000	14	1.5	72	8.1	1,772	200	2,037	230	3,543	400
C202_0250 MT30	24.64	1577/64	3,500	3,500	4,000	14	6.3	72	8.2	1,772	200	2,037	230	3,543	400
C202_0280 MT10	28.24	4067/144	4,000	3,900	6,000	14	0.9	72	8.1	1,772	200	2,037	230	2,707	306
C202_0280 MT20	28.24	4067/144	3,500	3,500	5,000	14	1.5	72	8.2	1,772	200	2,037	230	3,543	400
C202_0280 MT30	28.24	4067/144	3,500	3,500	4,000	14	6.3	73	8.2	1,772	200	2,037	230	3,543	400
C202_0310 MT10	30.69	399/13	4,000	3,900	6,000	14	0.8	72	8.2	1,772	200	2,037	230	2,793	315
C202_0310 MT20	30.69	399/13	3,500	3,500	5,000	14	1.4	72	8.2	1,772	200	2,037	230	3,543	400
C202_0310 MT30	30.69	399/13	3,500	3,500	4,000	14	6.2	73	8.2	1,772	200	2,037	230	3,543	400
C202_0350 MT10	35.18	1372/39	4,000	3,900	6,000	14	0.8	73	8.2	1,772	200	2,037	230	3,201	361
C202_0350 MT20	35.18	1372/39	3,500	3,500	5,000	14	1.4	73	8.2	1,772	200	2,037	230	3,543	400
C202_0350 MT30	35.18	1372/39	3,500	3,500	4,000	14	6.2	73	8.2	1,772	200	2,037	230	3,543	400
C202_0410 MT10	40.85	817/20	4,000	3,900	6,000	14	0.7	73	8.2	1,772	200	2,037	230	3,493	394
C202_0410 MT20	40.85	817/20	3,500	3,500	5,000	14	1.3	73	8.2	1,772	200	2,037	230	3,543	400
C202_0410 MT30	40.85	817/20	3,500	3,500	4,000	14	6.1	73	8.2	1,772	200	2,037	230	3,543	400
C202_0470 MT10	46.82	2107/45	4,000	3,900	6,000	14	0.7	73	8.2	1,772	200	2,037	230	3,543	400
C202_0470 MT20	46.82	2107/45	3,500	3,500	5,000	14	1.3	73	8.2	1,772	200	2,037	230	3,543	400
C202_0470 MT30	46.82	2107/45	3,500	3,500	4,000	14	6.1	73	8.3	1,772	200	2,037	230	3,543	400
C202_0490 MT10	49.23	1083/22	4,000	3,900	6,000	14	0.7	73	8.2	1,772	200	2,037	230	3,543	400
C202_0490 MT20	49.23	1083/22	3,500	3,500	5,000	14	1.3	73	8.2	1,772	200	2,037	230	3,543	400
C202_0560 MT10	56.42	1862/33	4,000	3,900	6,000	14	0.7	73	8.3	1,772	200	2,037	230	3,543	400
C202_0560 MT20	56.42	1862/33	3,500	3,500	5,000	14	1.3	73	8.3	1,772	200	2,037	230	3,543	400
C202_0610 MT10	61.35	2945/48	4,000	3,900	6,000	14	0.7	73	8.3	1,658	187	1,989	225	2,518	284
C202_0700 MT10	70.32	7595/108	4,000	3,900	6,000	14	0.7	73	8.3	1,772	200	2,037	230	2,886	326

C203 with MT TriAdapt® Motor Adapter *Continued Next Page*

Noise Level ≤ 53 dB(A)³⁾

C203_0800 MT20	79.59	7163/90	3,500	3,500	5,000	14	1.4	73	8.3	1,772	200	2,037	230	3,543	400
C203_0810 MT10	80.62	11609/144	4,000	3,900	6,000	14	0.7	73	8.3	1,772	200	2,037	230	3,543	400
C203_0910 MT20	91.23	36946/405	3,500	3,500	5,000	14	1.4	73	8.3	1,772	200	2,037	230	3,543	400
C203_0920 MT10	92.40	29939/324	4,000	3,900	6,000	14	0.7	73	8.3	1,772	200	2,037	230	3,543	400
C203_1090 MT20	109.2	117943/1080	3,500	3,500	5,000	14	1.4	73	8.3	1,772	200	2,037	230	3,543	400
C203_1110 MT10	110.6	191149/1728	4,000	3,900	6,000	14	0.7	73	8.3	1,772	200	2,037	230	3,543	400
C203_1360 MT20	136.0	79576/585	3,500	3,500	5,000	14	1.4	73	8.3	1,772	200	2,037	230	3,543	400
C203_1380 MT10	137.8	16121/117	4,000	3,900	6,000	14	0.7	73	8.3	1,772	200	2,037	230	3,543	400

Maximum Motor Shaft

Adapter	Diameter	Adapter	Diameter
MT10	19	MT40	48
MT20	24	MT50	60
MT30	38		

- ¹⁾ Maximum torque for continuous input RPM - horizontal output position.
²⁾ Maximum momentary torque for emergency stops or heavy shock load. Admissible stops per life of reducer = 1,000 stops maximum.
³⁾ dB(A) Measured at 1 meter distance with 3000 RPM input.



"C" Series – Concentric Helical ServoFit® Modular System Selection Data



Part Number	Reducer Ratio i		Input RPM			Backlash arcmins $\Delta\phi$	Input Inertia J ₁ kgcm ²	Torsional Stiffness per arcmin C ₂		Output Torque					
			Maximum							Nominal ¹⁾		Acceleration		Peak ²⁾	
	Nom.	Exact	Continuous	Cyclic	M _{2N} ≤ 2000 RPM			M _{2B}		M _{2PEAK}					
	n _{1DBH}	n _{1DBV}	n _{1ZB}		in.lbs.			Nm	in.lbs.	Nm	in.lbs.	Nm			
C203 with MT TriAdapt® Motor Adapter Continued															
Noise Level ≤ 53 dB(A)³⁾															
C203_1810 MT20	181.0	122206/675	3,500	3,500	5,000	14	1.4	73	8.3	1,772	200	2,037	230	3,543	400
C203_1830 MT10	183.4	99029/540	4,000	3,900	6,000	14	0.7	73	8.3	1,772	200	2,037	230	3,543	400
C203_2210 MT10	221.0	43757/198	4,000	3,900	6,000	14	0.7	73	8.3	1,772	200	2,037	230	3,543	400
C203_2750 MT10	275.4	356965/1296	4,000	3,900	6,000	14	0.6	73	8.3	1,772	200	2,037	230	2,885	326
C302 with MT TriAdapt® Motor Adapter Continued Next Page															
Noise Level ≤ 53 dB(A)³⁾															
C302_0020 MT20	2.020	608/301	2,700	2,300	4,000	16	8.2	16	1.8	694	78	764	86	1,159	131
C302_0020 MT30	2.020	608/301	2,700	2,300	4,000	16	13.0	23	2.6	1,367	154	1,814	205	2,988	337
C302_0020 MT40	2.020	608/301	2,700	2,300	3,500	16	17.0	34	3.9	1,367	154	2,309	261	2,988	337
C302_0022 MT20	2.177	468/215	2,700	2,300	4,000	16	7.8	18	2.1	748	84	823	93	1,249	141
C302_0022 MT30	2.177	468/215	2,700	2,300	4,000	16	12.6	25	2.8	1,402	158	1,955	221	3,221	364
C302_0022 MT40	2.177	468/215	2,700	2,300	3,500	16	16.6	37	4.1	1,402	158	2,368	267	3,221	364
C302_0025 MT20	2.510	1634/651	2,700	2,300	4,000	16	6.3	22	2.5	863	97	949	107	1,398	158
C302_0025 MT30	2.510	1634/651	2,700	2,300	4,000	16	11.1	29	3.3	1,470	166	2,254	254	3,607	407
C302_0025 MT40	2.510	1634/651	2,700	2,300	3,500	16	15.1	41	4.6	1,470	166	2,483	280	3,607	407
C302_0027 MT20	2.705	1677/620	2,700	2,300	4,000	16	6.1	24	2.7	930	105	1,023	115	1,507	170
C302_0027 MT30	2.705	1677/620	2,700	2,300	4,000	16	10.9	32	3.6	1,507	170	2,429	274	3,887	439
C302_0027 MT40	2.705	1677/620	2,700	2,300	3,500	16	14.9	43	4.8	1,507	170	2,546	287	3,887	439
C302_0031 MT20	3.110	1045/336	3,200	2,800	4,500	16	4.8	28	3.2	1,069	121	1,176	133	1,669	188
C302_0031 MT30	3.110	1045/336	3,200	2,800	4,000	16	9.6	36	4.1	1,579	178	2,667	301	4,304	486
C302_0031 MT40	3.110	1045/336	3,000	2,800	3,500	16	13.6	46	5.2	1,579	178	2,667	301	4,304	486
C302_0034 MT20	3.352	429/128	3,200	2,800	4,500	16	4.7	31	3.5	1,152	130	1,267	143	1,798	203
C302_0034 MT30	3.352	429/128	3,200	2,800	4,000	16	9.5	38	4.3	1,618	183	2,734	309	4,639	524
C302_0034 MT40	3.352	429/128	3,000	2,800	3,500	16	13.5	48	5.4	1,618	183	2,734	309	4,639	524
C302_0039 MT20	3.878	190/49	3,200	2,800	4,500	16	3.8	35	4.0	1,333	150	1,466	166	2,012	227
C302_0039 MT30	3.878	190/49	3,200	2,800	4,000	16	8.6	42	4.8	1,699	192	2,870	324	4,872	550
C302_0039 MT40	3.878	190/49	3,000	2,800	3,500	16	12.6	51	5.8	1,699	192	2,870	324	4,872	550
C302_0042 MT20	4.179	117/28	3,200	2,800	4,500	16	3.7	38	4.3	1,436	162	1,580	178	2,169	245
C302_0042 MT30	4.179	117/28	3,200	2,800	4,000	16	8.5	44	5.0	1,742	197	2,923	330	4,872	550
C302_0042 MT40	4.179	117/28	3,000	2,800	3,500	16	12.5	52	5.9	1,742	197	2,923	330	4,872	550
C302_0047 MT20	4.675	589/126	3,500	3,100	5,000	16	3.2	41	4.6	1,552	175	1,767	200	2,334	264
C302_0047 MT30	4.675	589/126	3,500	3,100	4,000	16	8.0	47	5.3	1,808	204	2,923	330	4,872	550
C302_0047 MT40	4.675	589/126	3,000	3,000	3,500	16	12.0	54	6.1	1,808	204	2,923	330	4,872	550
C302_0050 MT20	5.038	403/80	3,500	3,100	5,000	16	3.1	43	4.9	1,672	189	1,905	215	2,515	284
C302_0050 MT30	5.038	403/80	3,500	3,100	4,000	16	7.9	49	5.5	1,854	209	2,923	330	4,872	550
C302_0050 MT40	5.038	403/80	3,000	3,000	3,500	16	11.9	55	6.2	1,854	209	2,923	330	4,872	550
C302_0059 MT20	5.859	2584/441	3,500	3,100	5,000	16	2.6	47	5.3	1,702	192	2,215	250	2,829	319
C302_0059 MT30	5.859	2584/441	3,500	3,100	4,000	16	7.4	52	5.9	1,950	220	2,923	330	4,872	550
C302_0059 MT40	5.859	2584/441	3,000	3,000	3,500	16	11.4	57	6.4	1,950	220	2,923	330	4,872	550
C302_0063 MT20	6.314	221/35	3,500	3,100	5,000	16	2.6	49	5.5	1,834	207	2,387	269	3,049	344
C302_0063 MT30	6.314	221/35	3,500	3,100	4,000	16	7.4	53	6.0	1,999	226	2,923	330	4,872	550
C302_0063 MT40	6.314	221/35	3,000	3,000	3,500	16	11.4	58	6.5	1,999	226	2,923	330	4,872	550
C302_0078 MT20	7.841	494/63	3,500	3,500	5,000	16	2.1	53	5.9	1,771	200	2,845	321	3,556	401
C302_0078 MT30	7.841	494/63	3,500	3,500	4,000	16	6.9	56	6.3	2,148	243	2,923	330	4,872	550
C302_0078 MT40	7.841	494/63	3,000	3,000	3,500	16	10.9	59	6.7	2,148	243	2,923	330	4,872	550
C302_0083 MT20	8.250	33/4	3,200	2,800	4,500	13	3.8	64	7.2	2,638	298	3,119	352	4,426	500
C302_0083 MT30	8.250	33/4	3,200	2,800	4,000	13	8.6	68	7.7	2,638	298	3,543	400	6,201	700
C302_0083 MT40	8.250	33/4	3,000	2,800	3,500	13	12.6	73	8.2	2,638	298	3,543	400	6,201	700



See Page 188 for Options and Part Number Configuration.



"C" Series – Concentric Helical ServoFit® Modular System Selection Data



Part Number	Reducer Ratio i		Input RPM			Backlash arcmins $\Delta\phi$	Input Inertia J ₁ kgcm ²	Torsional Stiffness per arcmin C ₂		Output Torque					
			Maximum							Nominal ¹⁾		Acceleration		Peak ²⁾	
	Nom.	Exact	Continuous		Cyclic			M _{2N} ≤ 2000 RPM		M _{2B}		M _{2PEAK}			
			n _{1DBH}	n _{1DBV}				n _{1ZB}	in.lbs.	Nm	in.lbs.	Nm	in.lbs.	Nm	
C302 with MT TriAdapt® Motor Adapter <i>Continued</i> Noise Level ≤ 53 dB(A)³⁾															
C302_0093 MT20	9.310	3575/384	3,200	2,800	4,500	13	3.7	66	7.5	2,746	310	3,100	350	4,995	564
C302_0093 MT30	9.310	3575/384	3,200	2,800	4,000	13	8.5	70	7.9	2,746	310	3,100	350	6,201	700
C302_0093 MT40	9.310	3575/384	3,000	2,800	3,500	13	12.5	74	8.3	2,746	310	3,100	350	6,201	700
C302_0105 MT20	10.29	72/7	3,200	2,800	4,500	13	3.1	68	7.7	2,839	321	3,543	400	5,338	603
C302_0105 MT30	10.29	72/7	3,200	2,800	4,000	13	7.9	71	8.1	2,839	321	3,543	400	6,201	700
C302_0105 MT40	10.29	72/7	3,000	2,800	3,500	13	11.9	74	8.4	2,839	321	3,543	400	6,201	700
C302_0115 MT20	11.61	325/28	3,200	2,800	4,500	13	3.1	70	7.9	2,956	334	3,100	350	6,023	680
C302_0115 MT30	11.61	325/28	3,200	2,800	4,000	13	7.9	73	8.2	2,956	334	3,100	350	6,201	700
C302_0115 MT40	11.61	325/28	3,000	2,800	3,500	13	11.9	75	8.5	2,956	334	3,100	350	6,201	700
C302_0125 MT20	12.40	62/5	3,500	3,100	5,000	13	2.7	71	8.0	3,022	341	3,543	400	6,191	699
C302_0125 MT30	12.40	62/5	3,500	3,100	4,000	13	7.5	73	8.3	3,022	341	3,543	400	6,201	700
C302_0125 MT40	12.40	62/5	3,000	3,000	3,500	13	11.5	75	8.5	3,022	341	3,543	400	6,201	700
C302_0140 MT20	13.99	2015/144	3,500	3,100	5,000	13	2.7	72	8.1	3,100	350	3,100	350	6,201	700
C302_0140 MT30	13.99	2015/144	3,500	3,100	4,000	13	7.5	74	8.4	3,100	350	3,100	350	6,201	700
C302_0140 MT40	13.99	2015/144	3,000	3,000	3,500	13	11.5	76	8.5	3,100	350	3,100	350	6,201	700
C302_0155 MT20	15.54	544/35	3,500	3,100	5,000	13	2.3	73	8.2	3,100	350	3,543	400	6,201	700
C302_0155 MT30	15.54	544/35	3,500	3,100	4,000	13	7.1	75	8.4	3,100	350	3,543	400	6,201	700
C302_0155 MT40	15.54	544/35	3,000	3,000	3,500	13	11.1	76	8.6	3,100	350	3,543	400	6,201	700
C302_0175 MT20	17.54	1105/63	3,500	3,100	5,000	13	2.3	74	8.3	3,100	350	3,100	350	6,201	700
C302_0175 MT30	17.54	1105/63	3,500	3,100	4,000	13	7.1	75	8.5	3,100	350	3,100	350	6,201	700
C302_0175 MT40	17.54	1105/63	3,000	3,000	3,500	13	11.1	76	8.6	3,100	350	3,100	350	6,201	700
C302_0210 MT20	20.80	104/5	3,500	3,500	5,000	13	1.9	75	8.5	3,100	350	3,543	400	6,201	700
C302_0210 MT30	20.80	104/5	3,500	3,500	4,000	13	6.7	76	8.6	3,100	350	3,543	400	6,201	700
C302_0210 MT40	20.80	104/5	3,000	3,000	3,500	13	10.7	77	8.6	3,100	350	3,543	400	6,201	700
C302_0230 MT20	23.47	845/36	3,500	3,500	5,000	13	1.9	75	8.5	3,100	350	3,100	350	6,201	700
C302_0230 MT30	23.47	845/36	3,500	3,500	4,000	13	6.7	76	8.6	3,100	350	3,100	350	6,201	700
C302_0230 MT40	23.47	845/36	3,000	3,000	3,500	13	10.7	77	8.7	3,100	350	3,100	350	6,201	700
C302_0250 MT20	24.80	124/5	3,500	3,500	5,000	13	1.7	76	8.5	3,100	350	3,543	400	6,201	700
C302_0250 MT30	24.80	124/5	3,500	3,500	4,000	13	6.5	76	8.6	3,100	350	3,543	400	6,201	700
C302_0250 MT40	24.80	124/5	3,000	3,000	3,500	13	10.5	77	8.7	3,100	350	3,543	400	6,201	700
C302_0280 MT20	27.99	2015/72	3,500	3,500	5,000	13	1.7	76	8.6	3,100	350	3,100	350	6,201	700
C302_0280 MT30	27.99	2015/72	3,500	3,500	4,000	13	6.5	76	8.6	3,100	350	3,100	350	6,201	700
C302_0280 MT40	27.99	2015/72	3,000	3,000	3,500	13	10.5	77	8.7	3,100	350	3,100	350	6,201	700
C302_0310 MT20	31.04	776/25	3,500	3,500	5,000	13	1.6	76	8.6	3,100	350	3,543	400	6,201	700
C302_0310 MT30	31.04	776/25	3,500	3,500	4,000	13	6.4	77	8.7	3,100	350	3,543	400	6,201	700
C302_0310 MT40	31.04	776/25	3,000	3,000	3,500	13	10.4	77	8.7	3,100	350	3,543	400	6,201	700
C302_0350 MT20	35.03	1261/36	3,500	3,500	5,000	13	1.6	76	8.6	3,100	350	3,100	350	6,201	700
C302_0350 MT30	35.03	1261/36	3,500	3,500	4,000	13	6.4	77	8.7	3,100	350	3,100	350	6,201	700
C302_0350 MT40	35.03	1261/36	3,000	3,000	3,500	13	10.4	77	8.7	3,100	350	3,100	350	6,201	700
C302_0410 MT20	41.35	2688/65	3,500	3,500	5,000	13	1.4	77	8.7	3,100	350	3,543	400	6,201	700
C302_0410 MT30	41.35	2688/65	3,500	3,500	4,000	13	6.2	77	8.7	3,100	350	3,543	400	6,201	700
C302_0470 MT20	46.67	140/3	3,500	3,500	5,000	13	1.4	77	8.7	3,100	350	3,100	350	6,201	700
C302_0470 MT30	46.67	140/3	3,500	3,500	4,000	13	6.2	77	8.7	3,100	350	3,100	350	6,201	700
C302_0500 MT20	49.75	2736/55	3,500	3,500	5,000	13	1.4	77	8.7	3,100	350	3,543	400	6,201	700
C302_0500 MT30	49.75	2736/55	3,500	3,500	4,000	13	6.2	77	8.7	3,100	350	3,543	400	6,201	700
C302_0560 MT20	56.14	1235/22	3,500	3,500	5,000	13	1.4	77	8.7	3,100	350	3,100	350	6,201	700
C302_0560 MT30	56.14	1235/22	3,500	3,500	4,000	13	6.2	77	8.7	3,100	350	3,100	350	6,201	700
C302_0620 MT20	61.92	1548/25	3,500	3,500	5,000	13	1.3	77	8.7	2,932	331	3,518	397	4,990	563
C302_0700 MT20	69.88	559/8	3,500	3,500	5,000	13	1.3	77	8.7	3,100	350	3,100	350	5,631	636

Maximum Motor Shaft			
Adapter	Diameter	Adapter	Diameter
MT10	19	MT40	48
MT20	24	MT50	60
MT30	38		

¹⁾ Maximum torque for continuous input RPM - horizontal output position.
²⁾ Maximum momentary torque for emergency stops or heavy shock load. Admissible stops per life of reducer = 1,000 stops maximum.
³⁾ dB(A) Measured at 1 meter distance with 3000 RPM input.



"C" Series – Concentric Helical ServoFit® Modular System Selection Data



Part Number	Reducer Ratio i		Input RPM			Backlash arcmins $\Delta\phi$	Input Inertia J ₁ kgcm ²	Torsional Stiffness per arcmin C ₂		Output Torque					
			Maximum							Nominal ¹⁾		Acceleration		Peak ²⁾	
	Nom.	Exact	n_{1DBH}	n_{1DBV}	n_{1ZB}			$M_{2N \leq 2000 \text{ RPM}}$		M_{2B}		M_{2PEAK}			
								in.lbs.	Nm	in.lbs.	Nm	in.lbs.	Nm		
C303 with MT TriAdapt® Motor Adapter Noise Level ≤ 53 dB(A)³⁾															
C303_0800 MT20	80.43	6032/75	3,500	3,500	5,000	13	1.4	77	8.7	3,100	350	3,543	400	6,201	700
C303_0810 MT10	81.47	1222/15	3,800	3,500	5,500	13	0.7	77	8.7	2,954	334	2,954	334	3,693	417
C303_0910 MT20	90.76	4901/54	3,500	3,500	5,000	13	1.4	77	8.7	3,100	350	3,100	350	6,201	700
C303_0920 MT10	91.93	39715/432	3,800	3,500	5,500	13	0.7	77	8.7	3,100	350	3,100	350	4,167	470
C303_1080 MT20	108.2	11687/108	3,500	3,500	5,000	13	1.4	77	8.7	3,100	350	3,100	350	6,201	700
C303_1100 MT10	109.6	94705/864	3,800	3,500	5,500	13	0.7	77	8.7	3,100	350	3,100	350	4,969	561
C303_1350 MT20	135.4	36569/270	3,500	3,500	5,000	13	1.4	77	8.7	3,100	350	3,100	350	6,201	700
C303_1370 MT10	137.2	59267/432	3,800	3,500	5,500	13	0.7	77	8.7	3,100	350	3,100	350	6,201	700
C303_1800 MT20	180.4	1624/9	3,500	3,500	5,000	13	1.4	77	8.7	3,100	350	3,100	350	6,201	700
C303_1830 MT10	182.8	1645/9	3,800	3,500	5,500	13	0.7	77	8.7	3,100	350	3,100	350	6,201	700
C303_2170 MT20	217.1	7163/33	3,500	3,500	5,000	13	1.4	77	8.7	3,100	350	3,100	350	6,201	700
C303_2200 MT10	219.9	58045/264	3,800	3,500	5,500	13	0.7	77	8.7	3,100	350	3,100	350	6,201	700
C303_2740 MT10	273.7	26273/96	3,800	3,500	5,500	13	0.7	77	8.7	3,100	350	3,100	350	5,631	636
C402 with MT TriAdapt® Motor Adapter Noise Level ≤ 61 dB(A)³⁾															
C402_0020 MT30	1.968	551/280	2,500	2,100	3,500	15	23.1	28	3.1	1,606	181	1,767	199	3,029	342
C402_0020 MT40	1.968	551/280	2,500	2,100	3,500	15	27.1	49	5.5	1,971	223	2,424	274	3,029	342
C402_0022 MT30	2.221	171/77	2,500	2,100	3,500	15	21.2	34	3.8	1,813	205	1,994	225	3,419	386
C402_0022 MT40	2.221	171/77	2,500	2,100	3,500	15	25.2	57	6.4	2,052	232	2,735	309	3,419	386
C402_0025 MT30	2.456	609/248	2,500	2,100	3,500	15	18.2	39	4.4	2,005	226	2,205	249	3,668	414
C402_0025 MT40	2.456	609/248	2,500	2,100	3,500	15	22.2	64	7.2	2,122	240	2,934	331	3,668	414
C402_0028 MT30	2.771	945/341	2,500	2,100	3,500	15	17.0	47	5.3	2,209	249	2,488	281	4,138	467
C402_0028 MT40	2.771	945/341	2,500	2,100	3,500	15	21.0	73	8.3	2,209	249	3,311	374	4,138	467
C402_0031 MT30	3.099	1537/496	2,900	2,500	4,000	15	14.5	54	6.1	2,293	259	2,783	314	4,453	503
C402_0031 MT40	3.099	1537/496	2,900	2,500	3,500	15	18.5	82	9.2	2,293	259	3,562	402	4,453	503
C402_0035 MT30	3.497	2385/682	2,900	2,500	4,000	15	13.7	63	7.1	2,388	270	3,140	354	5,025	567
C402_0035 MT40	3.497	2385/682	2,900	2,500	3,500	15	17.7	91	10.2	2,388	270	4,020	454	5,025	567
C402_0039 MT20	3.894	841/216	2,900	2,500	4,000	15	7.2	53	6.0	1,338	151	1,472	166	2,088	236
C402_0039 MT30	3.894	841/216	2,900	2,500	4,000	15	12.0	71	8.0	2,475	279	3,496	395	5,385	608
C402_0039 MT40	3.894	841/216	2,900	2,500	3,500	15	16.0	98	11.1	2,475	279	4,181	472	5,385	608
C402_0044 MT20	4.394	145/33	2,900	2,500	4,000	15	6.7	62	7.0	1,510	170	1,661	188	2,356	266
C402_0044 MT30	4.394	145/33	2,900	2,500	4,000	15	11.5	80	9.0	2,576	291	3,945	445	6,077	686
C402_0044 MT40	4.394	145/33	2,900	2,500	3,500	15	15.5	106	12.0	2,576	291	4,353	491	6,077	686
C402_0047 MT20	4.682	899/192	3,300	2,800	4,500	15	5.8	66	7.5	1,609	182	1,770	200	2,438	275
C402_0047 MT30	4.682	899/192	3,300	2,800	4,000	15	10.6	84	9.5	2,632	297	4,204	475	6,287	710
C402_0047 MT40	4.682	899/192	3,000	2,800	3,500	15	14.6	110	12.4	2,632	297	4,446	502	6,287	710
C402_0053 MT20	5.284	465/88	3,300	2,800	4,500	15	5.4	75	8.5	1,816	205	1,998	226	2,751	311
C402_0053 MT30	5.284	465/88	3,300	2,800	4,000	15	10.2	93	10.5	2,740	309	4,629	523	7,096	801
C402_0053 MT40	5.284	465/88	3,000	2,800	3,500	15	14.2	117	13.2	2,740	309	4,629	523	7,096	801
C402_0059 MT20	5.891	377/64	3,300	2,800	4,500	15	4.4	84	9.4	1,927	218	2,227	251	2,930	331
C402_0059 MT30	5.891	377/64	3,300	2,800	4,000	15	9.2	101	11.4	2,841	321	4,799	542	7,529	850
C402_0059 MT40	5.891	377/64	3,000	2,800	3,500	15	13.2	122	13.8	2,841	321	4,799	542	7,529	850
C402_0066 MT20	6.648	585/88	3,300	2,800	4,500	15	4.2	92	10.4	2,174	245	2,513	284	3,307	373
C402_0066 MT30	6.648	585/88	3,300	2,800	4,000	15	9.0	109	12.3	2,958	334	4,872	550	7,529	850
C402_0066 MT40	6.648	585/88	3,000	2,800	3,500	15	13.0	127	14.4	2,958	334	4,872	550	7,529	850
C402_0078 MT20	7.816	2001/256	3,500	3,200	5,000	15	3.3	103	11.7	2,045	231	2,942	332	3,677	415
C402_0078 MT30	7.816	2001/256	3,500	3,200	4,000	15	8.1	118	13.3	3,122	352	4,872	550	7,529	850
C402_0078 MT40	7.816	2001/256	3,000	3,000	3,500	15	12.1	133	15.0	3,122	352	4,872	550	7,529	850

C

See Page 188 for Options and Part Number Configuration.



"C" Series – Concentric Helical ServoFit® Modular System Selection Data



Part Number	Reducer Ratio i		Input RPM			Backlash arcmins $\Delta\phi$	Input Inertia J ₁ kgcm ²	Torsional Stiffness per arcmin C ₂		Output Torque					
			Maximum							Nominal ¹⁾		Acceleration		Peak ²⁾	
	Nom.	Exact	Continuous	Cyclic	M _{2N} ≤ 2000 RPM			M _{2B}	M _{2PEAK}						
			n_{1DBH}							n_{1DBV}	n_{1ZB}	in.lbs.	Nm	in.lbs.	Nm

C402 with MT TriAdapt® Motor Adapter *Continued Next Page*

Noise Level ≤ 61 dB(A) ³⁾

C402_0083 MT30	8.285	3339/403	2,900	2,500	4,000	12	11.9	146	16.5	4,432	500	5,315	600	9,744	1,100
C402_0083 MT40	8.285	3339/403	2,900	2,500	3,500	12	15.9	168	18.9	4,432	500	5,315	600	9,744	1,100
C402_0093 MT30	9.261	3445/372	2,900	2,500	4,000	12	11.8	154	17.4	4,600	519	4,872	550	9,744	1,100
C402_0093 MT40	9.261	3445/372	2,900	2,500	3,500	12	15.8	172	19.5	4,600	519	4,872	550	9,744	1,100
C402_0105 MT20	10.41	406/39	2,900	2,500	4,000	12	5.6	145	16.4	3,578	404	3,936	444	5,582	630
C402_0105 MT30	10.41	406/39	2,900	2,500	4,000	12	10.4	161	18.1	4,783	540	5,315	600	9,744	1,100
C402_0105 MT40	10.41	406/39	2,900	2,500	3,500	12	14.4	176	19.9	4,783	540	5,315	600	9,744	1,100
C402_0115 MT20	11.64	1885/162	2,900	2,500	4,000	12	5.5	153	17.3	3,999	451	4,399	497	6,239	704
C402_0115 MT30	11.64	1885/162	2,900	2,500	4,000	12	10.3	166	18.8	4,872	550	4,872	550	9,744	1,100
C402_0115 MT40	11.64	1885/162	2,900	2,500	3,500	12	14.3	179	20.3	4,872	550	4,872	550	9,744	1,100
C402_0125 MT20	12.52	651/52	3,300	2,800	4,500	12	4.6	157	17.8	4,303	486	4,733	534	6,518	736
C402_0125 MT30	12.52	651/52	3,300	2,800	4,000	12	9.4	169	19.1	4,872	550	5,315	600	9,744	1,100
C402_0125 MT40	12.52	651/52	3,000	2,800	3,500	12	13.4	181	20.5	4,872	550	5,315	600	9,744	1,100
C402_0140 MT20	13.99	2015/144	3,300	2,800	4,500	12	4.6	163	18.5	4,809	543	4,872	550	7,285	822
C402_0140 MT30	13.99	2015/144	3,300	2,800	4,000	12	9.4	174	19.6	4,872	550	4,872	550	9,744	1,100
C402_0140 MT40	13.99	2015/144	3,000	2,800	3,500	12	13.4	183	20.7	4,872	550	4,872	550	9,744	1,100
C402_0160 MT20	15.75	63/4	3,300	2,800	4,500	12	3.7	169	19.1	4,872	550	5,315	600	7,835	884
C402_0160 MT30	15.75	63/4	3,300	2,800	4,000	12	8.5	178	20.0	4,872	550	5,315	600	9,744	1,100
C402_0160 MT40	15.75	63/4	3,000	2,800	3,500	12	12.5	185	20.9	4,872	550	5,315	600	9,744	1,100
C402_0175 MT20	17.60	845/48	3,300	2,800	4,500	12	3.7	173	19.6	4,872	550	4,872	550	8,757	989
C402_0175 MT30	17.60	845/48	3,300	2,800	4,000	12	8.5	180	20.4	4,872	550	4,872	550	9,744	1,100
C402_0175 MT40	17.60	845/48	3,000	2,800	3,500	12	12.5	187	21.1	4,872	550	4,872	550	9,744	1,100
C402_0210 MT20	20.90	4347/208	3,500	3,200	5,000	12	2.9	179	20.2	4,872	550	5,315	600	9,744	1,100
C402_0210 MT30	20.90	4347/208	3,500	3,200	4,000	12	7.7	184	20.8	4,872	550	5,315	600	9,744	1,100
C402_0210 MT40	20.90	4347/208	3,000	3,000	3,500	12	11.7	189	21.3	4,872	550	5,315	600	9,744	1,100
C402_0230 MT20	23.36	1495/64	3,500	3,200	5,000	12	2.9	181	20.5	4,872	550	4,872	550	9,744	1,100
C402_0230 MT30	23.36	1495/64	3,500	3,200	4,000	12	7.7	186	21.0	4,872	550	4,872	550	9,744	1,100
C402_0230 MT40	23.36	1495/64	3,000	3,000	3,500	12	11.7	190	21.4	4,872	550	4,872	550	9,744	1,100
C402_0250 MT20	24.92	324/13	3,500	3,200	5,000	12	2.5	183	20.6	4,872	550	5,315	600	9,744	1,100
C402_0250 MT30	24.92	324/13	3,500	3,200	4,000	12	7.3	187	21.1	4,872	550	5,315	600	9,744	1,100
C402_0250 MT40	24.92	324/13	3,000	3,000	3,500	12	11.3	190	21.5	4,872	550	5,315	600	9,744	1,100
C402_0280 MT20	27.86	195/7	3,500	3,200	5,000	12	2.5	185	20.9	4,872	550	4,872	550	9,744	1,100
C402_0280 MT30	27.86	195/7	3,500	3,200	4,000	12	7.3	188	21.2	4,872	550	4,872	550	9,744	1,100
C402_0280 MT40	27.86	195/7	3,000	3,000	3,500	12	11.3	191	21.5	4,872	550	4,872	550	9,744	1,100
C402_0310 MT20	31.15	405/13	3,500	3,200	5,000	12	2.1	186	21.0	4,872	550	5,315	600	9,744	1,100
C402_0310 MT30	31.15	405/13	3,500	3,200	4,000	12	6.9	189	21.3	4,872	550	5,315	600	9,744	1,100
C402_0310 MT40	31.15	405/13	3,000	3,000	3,500	12	10.9	191	21.6	4,872	550	5,315	600	9,744	1,100
C402_0350 MT20	34.82	975/28	3,500	3,200	5,000	12	2.1	188	21.2	4,872	550	4,872	550	9,744	1,100
C402_0350 MT30	34.82	975/28	3,500	3,200	4,000	12	6.9	190	21.4	4,872	550	4,872	550	9,744	1,100
C402_0350 MT40	34.82	975/28	3,000	3,000	3,500	12	10.9	192	21.6	4,872	550	4,872	550	9,744	1,100
C402_0420 MT20	41.75	7056/169	3,500	3,200	5,000	12	1.8	189	21.4	4,872	550	5,315	600	9,744	1,100
C402_0420 MT30	41.75	7056/169	3,500	3,200	4,000	12	6.6	191	21.5	4,872	550	5,315	600	9,744	1,100
C402_0420 MT40	41.75	7056/169	3,000	3,000	3,500	12	10.6	192	21.7	4,872	550	5,315	600	9,744	1,100
C402_0470 MT20	46.67	140/3	3,500	3,200	5,000	12	1.7	190	21.5	4,872	550	4,872	550	9,744	1,100
C402_0470 MT30	46.67	140/3	3,500	3,200	4,000	12	6.5	191	21.6	4,872	550	4,872	550	9,744	1,100
C402_0470 MT40	46.67	140/3	3,000	3,000	3,500	12	10.5	192	21.7	4,872	550	4,872	550	9,744	1,100
C402_0500 MT20	50.19	1305/26	3,500	3,200	5,000	12	1.6	191	21.5	4,872	550	5,315	600	8,313	938
C402_0500 MT30	50.19	1305/26	3,500	3,200	4,000	12	6.4	192	21.6	4,872	550	5,315	600	8,313	938

Maximum Motor Shaft

Adapter	Diameter	Adapter	Diameter
MT10	19	MT40	48
MT20	24	MT50	60
MT30	38		

- ¹⁾ Maximum torque for continuous input RPM - horizontal output position.
- ²⁾ Maximum momentary torque for emergency stops or heavy shock load. Admissible stops per life of reducer = 1,000 stops maximum.
- ³⁾ dB(A) Measured at 1 meter distance with 3000 RPM input.



"C" Series – Concentric Helical ServoFit® Modular System Selection Data



Part Number	Reducer Ratio i		Input RPM			Backlash arcmins $\Delta\phi$	Input Inertia J ₁ kgcm ²	Torsional Stiffness per arcmin C ₂		Output Torque					
			Maximum							Nominal ¹⁾		Acceleration		Peak ²⁾	
	Nom.	Exact	n _{1DBH}	n _{1DBV}	n _{1ZB}			M _{2N ≤ 2000 RPM}		M _{2B}		M _{2PEAK}			
								Continuous	Cyclic	in.lbs.	Nm	in.lbs.	Nm	in.lbs.	Nm
C402 with MT TriAdapt® Motor Adapter <i>Continued</i> Noise Level ≤ 61 dB(A) ³⁾															
C402_0560 MT20	56.10	9425/168	3,500	3,200	5,000	12	1.6	191	21.6	4,872	550	4,872	550	9,292	1,049
C402_0560 MT30	56.10	9425/168	3,500	3,200	4,000	12	6.4	192	21.7	4,872	550	4,872	550	9,292	1,049
C402_0630 MT20	62.52	8127/130	3,500	3,200	5,000	12	1.5	192	21.6	4,440	501	5,315	600	8,879	1,002
C402_0630 MT30	62.52	8127/130	3,500	3,200	4,000	12	6.3	192	21.7	4,440	501	5,315	600	8,879	1,002
C402_0700 MT20	69.88	559/8	3,500	3,200	5,000	12	1.5	192	21.7	4,872	550	4,872	550	9,744	1,100
C402_0700 MT30	69.88	559/8	3,500	3,200	4,000	12	6.3	192	21.7	4,872	550	4,872	550	9,744	1,100
C403 with MT TriAdapt® Motor Adapter Noise Level ≤ 61 dB(A) ³⁾															
C403_0810 MT20	80.81	42021/520	3,500	3,200	5,000	12	1.5	192	21.7	4,872	550	5,315	600	9,744	1,100
C403_0900 MT20	90.32	8671/96	3,500	3,200	5,000	12	1.5	192	21.7	4,872	550	4,872	550	9,744	1,100
C403_1080 MT20	107.7	754/7	3,500	3,200	5,000	12	1.5	193	21.8	4,872	550	4,872	550	9,744	1,100
C403_1350 MT20	134.6	1885/14	3,500	3,200	5,000	12	1.4	193	21.8	4,872	550	4,872	550	9,744	1,100
C403_1800 MT20	180.4	1624/9	3,500	3,200	5,000	12	1.4	193	21.8	4,872	550	4,872	550	9,744	1,100
C403_2170 MT20	216.9	54665/252	3,500	3,200	5,000	12	1.4	193	21.8	4,872	550	4,872	550	9,291	1,049
C403_2700 MT20	270.2	16211/60	3,500	3,200	5,000	12	1.4	193	21.8	4,872	550	4,872	550	9,744	1,100
C502 with MT TriAdapt® Motor Adapter <i>Continued Next Page</i> Noise Level ≤ 61 dB(A) ³⁾															
C502_0020 MT30	1.976	81/41	2,400	2,000	3,000	14	36.0	29	3.3	1,613	182	1,774	200	3,142	355
C502_0020 MT40	1.976	81/41	2,400	2,000	3,000	14	40.0	52	5.9	2,514	284	2,514	284	3,142	355
C502_0020 MT50	1.976	81/41	2,400	2,000	3,000	14	50.0	103	11.6	3,060	345	4,804	542	6,005	678
C502_0022 MT30	2.247	645/287	2,400	2,000	3,000	14	33.8	36	4.0	1,834	207	2,018	228	3,573	403
C502_0022 MT40	2.247	645/287	2,400	2,000	3,000	14	37.8	62	7.0	2,859	323	2,859	323	3,573	403
C502_0022 MT50	2.247	645/287	2,400	2,000	3,000	14	47.8	114	12.9	3,193	361	5,395	609	6,828	771
C502_0025 MT30	2.450	49/20	2,400	2,000	3,000	14	27.6	41	4.6	2,000	226	2,200	248	3,784	427
C502_0025 MT40	2.450	49/20	2,400	2,000	3,000	14	31.6	70	7.9	3,027	342	3,027	342	3,784	427
C502_0025 MT50	2.450	49/20	2,400	2,000	3,000	14	41.6	122	13.8	3,287	371	5,553	627	7,231	816
C502_0028 MT30	2.787	301/108	2,400	2,000	3,000	14	26.1	50	5.6	2,275	257	2,502	283	4,305	486
C502_0028 MT40	2.787	301/108	2,400	2,000	3,000	14	30.1	81	9.2	3,431	387	3,444	389	4,305	486
C502_0028 MT50	2.787	301/108	2,400	2,000	3,000	14	40.1	133	15.0	3,431	387	5,797	654	8,226	929
C502_0031 MT30	3.077	477/155	2,800	2,400	3,500	14	21.3	58	6.5	2,512	284	2,763	312	4,595	519
C502_0031 MT40	3.077	477/155	2,800	2,400	3,500	14	25.3	91	10.2	3,546	400	3,676	415	4,595	519
C502_0031 MT50	3.077	477/155	2,500	2,400	3,000	14	35.3	140	15.8	3,546	400	3,676	415	4,595	519
C502_0035 MT30	3.501	2279/651	2,800	2,400	3,500	14	20.4	68	7.7	2,858	323	3,144	355	5,228	590
C502_0035 MT40	3.501	2279/651	2,800	2,400	3,500	14	24.4	103	11.6	3,702	418	4,183	472	5,228	590
C502_0035 MT50	3.501	2279/651	2,500	2,400	3,000	14	34.4	149	16.8	3,702	418	4,183	472	5,228	590
C502_0039 MT30	3.867	58/15	2,800	2,400	3,500	14	17.0	77	8.7	3,156	356	3,472	392	5,579	630
C502_0039 MT40	3.867	58/15	2,800	2,400	3,500	14	21.0	112	12.6	3,827	432	4,463	504	5,579	630
C502_0039 MT50	3.867	58/15	2,500	2,400	3,000	14	31.0	154	17.4	3,827	432	4,463	504	5,579	630
C502_0044 MT30	4.399	2494/567	2,800	2,400	3,500	14	16.4	89	10.1	3,591	405	3,950	446	6,346	716
C502_0044 MT40	4.399	2494/567	2,800	2,400	3,500	14	20.4	123	13.9	3,995	451	5,077	573	6,346	716
C502_0044 MT50	4.399	2494/567	2,500	2,400	3,000	14	30.4	161	18.2	3,995	451	5,077	573	6,346	716
C502_0046 MT20	4.629	162/35	3,100	2,700	4,000	14	9.4	72	8.1	1,591	180	1,750	198	2,496	282
C502_0046 MT30	4.629	162/35	3,100	2,700	4,000	14	14.2	94	10.6	3,512	396	4,156	469	6,439	727
C502_0046 MT40	4.629	162/35	3,000	2,700	3,500	14	18.2	128	14.4	4,063	459	5,151	582	6,439	727
C502_0046 MT50	4.629	162/35	2,500	2,500	3,000	14	28.2	163	18.4	4,063	459	5,151	582	6,439	727



See Page 188 for Options and Part Number Configuration.



"C" Series – Concentric Helical ServoFit® Modular System Selection Data



Part Number	Reducer Ratio i		Input RPM			Backlash arcmins $\Delta\phi$	Input Inertia J ₁ kgcm ²	Torsional Stiffness per arcmin C ₂		Output Torque					
			Maximum							Nominal ¹⁾		Acceleration		Peak ²⁾	
	Nom.	Exact	n_{1DBH}	n_{1DBV}	n_{1ZB}			$M_{2N \leq 2000 \text{ RPM}}$		M_{2B}		M_{2PEAK}			
								Continuous	Cyclic	in.lbs.	Nm	in.lbs.	Nm	in.lbs.	Nm
C502 with MT TriAdapt® Motor Adapter <i>Continued Next Page</i>										Noise Level $\leq 61 \text{ dB(A)}$ ³⁾					
C502_0053 MT20	5.265	258/49	3,100	2,700	4,000	14	9.0	83	9.4	1,810	204	1,990	225	2,839	321
C502_0053 MT30	5.265	258/49	3,100	2,700	4,000	14	13.8	106	12.0	3,994	451	4,727	534	7,323	827
C502_0053 MT40	5.265	258/49	3,000	2,700	3,500	14	17.8	138	15.5	4,242	479	5,859	661	7,323	827
C502_0053 MT50	5.265	258/49	2,500	2,500	3,000	14	27.8	168	19.0	4,242	479	5,859	661	7,323	827
C502_0059 MT20	5.850	117/20	3,100	2,700	4,000	14	7.1	93	10.5	2,011	227	2,212	250	3,036	343
C502_0059 MT30	5.850	117/20	3,100	2,700	4,000	14	11.9	116	13.1	3,804	429	5,253	593	7,830	884
C502_0059 MT40	5.850	117/20	3,000	2,700	3,500	14	15.9	145	16.4	4,393	496	6,264	707	7,830	884
C502_0059 MT50	5.850	117/20	2,500	2,500	3,000	14	25.9	172	19.4	4,393	496	6,264	707	7,830	884
C502_0067 MT20	6.655	559/84	3,100	2,700	4,000	14	6.8	105	11.9	2,287	258	2,516	284	3,453	390
C502_0067 MT30	6.655	559/84	3,100	2,700	4,000	14	11.6	127	14.3	4,328	489	5,975	675	8,907	1,006
C502_0067 MT40	6.655	559/84	3,000	2,700	3,500	14	15.6	153	17.3	4,586	518	7,086	800	8,907	1,006
C502_0067 MT50	6.655	559/84	2,500	2,500	3,000	14	25.6	175	19.8	4,586	518	7,086	800	8,907	1,006
C502_0078 MT20	7.763	621/80	3,400	3,000	4,500	14	5.0	119	13.5	2,405	272	2,935	331	3,810	430
C502_0078 MT30	7.763	621/80	3,400	3,000	4,000	14	9.8	139	15.7	4,039	456	6,970	787	9,826	1,109
C502_0078 MT40	7.763	621/80	3,000	3,000	3,500	14	13.8	161	18.2	4,828	545	7,086	800	9,826	1,109
C502_0078 MT50	7.763	621/80	2,500	2,500	3,000	14	23.8	178	20.1	4,828	545	7,086	800	9,826	1,109
C502_0083 MT30	8.263	1537/186	2,800	2,400	3,500	12	16.9	150	17.0	6,642	750	7,419	838	12,340	1,393
C502_0083 MT40	8.263	1537/186	2,800	2,400	3,500	12	20.9	173	19.6	6,642	750	8,149	920	12,340	1,393
C502_0083 MT50	8.263	1537/186	2,500	2,400	3,000	12	30.9	191	21.6	6,642	750	8,149	920	12,340	1,393
C502_0093 MT30	9.261	3445/372	2,800	2,400	3,500	12	16.6	159	17.9	6,900	779	7,529	850	13,830	1,561
C502_0093 MT40	9.261	3445/372	2,800	2,400	3,500	12	20.6	178	20.1	6,900	779	7,529	850	13,830	1,561
C502_0093 MT50	9.261	3445/372	2,500	2,400	3,000	12	30.6	193	21.8	6,900	779	7,529	850	13,830	1,561
C502_0105 MT30	10.38	841/81	2,800	2,400	3,500	12	14.1	166	18.7	7,086	800	8,149	920	14,173	1,600
C502_0105 MT40	10.38	841/81	2,800	2,400	3,500	12	18.1	183	20.6	7,086	800	8,149	920	14,173	1,600
C502_0105 MT50	10.38	841/81	2,500	2,400	3,000	12	28.1	195	22.0	7,086	800	8,149	920	14,173	1,600
C502_0115 MT30	11.64	1885/162	2,800	2,400	3,500	12	13.9	172	19.4	7,086	800	7,529	850	14,173	1,600
C502_0115 MT40	11.64	1885/162	2,800	2,400	3,500	12	17.9	186	21.0	7,086	800	7,529	850	14,173	1,600
C502_0115 MT50	11.64	1885/162	2,500	2,400	3,000	12	27.9	196	22.1	7,086	800	7,529	850	14,173	1,600
C502_0125 MT20	12.43	87/7	3,100	2,700	4,000	12	7.4	162	18.3	4,272	482	4,699	530	6,703	757
C502_0125 MT30	12.43	87/7	3,100	2,700	4,000	12	12.2	175	19.8	7,086	800	8,149	920	14,173	1,600
C502_0125 MT40	12.43	87/7	3,000	2,700	3,500	12	16.2	188	21.2	7,086	800	8,149	920	14,173	1,600
C502_0125 MT50	12.43	87/7	2,500	2,500	3,000	12	26.2	197	22.2	7,086	800	8,149	920	14,173	1,600
C502_0140 MT20	13.93	195/14	3,100	2,700	4,000	12	7.3	169	19.0	4,787	540	5,266	594	7,512	848
C502_0140 MT30	13.93	195/14	3,100	2,700	4,000	12	12.1	180	20.3	7,086	800	7,529	850	14,173	1,600
C502_0140 MT40	13.93	195/14	3,000	2,700	3,500	12	16.1	190	21.5	7,086	800	7,529	850	14,173	1,600
C502_0140 MT50	13.93	195/14	2,500	2,500	3,000	12	26.1	197	22.3	7,086	800	7,529	850	14,173	1,600
C502_0155 MT20	15.71	377/24	3,100	2,700	4,000	12	5.8	175	19.7	5,399	609	5,939	670	8,151	920
C502_0155 MT30	15.71	377/24	3,100	2,700	4,000	12	10.6	184	20.8	7,086	800	8,149	920	14,173	1,600
C502_0155 MT40	15.71	377/24	3,000	2,700	3,500	12	14.6	193	21.7	7,086	800	8,149	920	14,173	1,600
C502_0155 MT50	15.71	377/24	2,500	2,500	3,000	12	24.6	198	22.4	7,086	800	8,149	920	14,173	1,600
C502_0175 MT20	17.60	845/48	3,100	2,700	4,000	12	5.8	179	20.3	6,050	683	6,655	751	9,135	1,031
C502_0175 MT30	17.60	845/48	3,100	2,700	4,000	12	10.6	187	21.1	7,086	800	7,529	850	14,173	1,600
C502_0175 MT40	17.60	845/48	3,000	2,700	3,500	12	14.6	194	21.9	7,086	800	7,529	850	14,173	1,600
C502_0175 MT50	17.60	845/48	2,500	2,500	3,000	12	24.6	199	22.4	7,086	800	7,529	850	14,173	1,600
C502_0210 MT20	20.84	667/32	3,400	3,000	4,500	12	4.3	185	20.9	6,458	729	7,880	890	10,229	1,155
C502_0210 MT30	20.84	667/32	3,400	3,000	4,000	12	9.1	191	21.6	7,086	800	8,149	920	14,173	1,600
C502_0210 MT40	20.84	667/32	3,000	3,000	3,500	12	13.1	196	22.1	7,086	800	8,149	920	14,173	1,600
C502_0210 MT50	20.84	667/32	2,500	2,500	3,000	12	23.1	199	22.5	7,086	800	8,149	920	14,173	1,600

Maximum Motor Shaft			
Adapter	Diameter	Adapter	Diameter
MT10	19	MT40	48
MT20	24	MT50	60
MT30	38		

¹⁾ Maximum torque for continuous input RPM - horizontal output position.
²⁾ Maximum momentary torque for emergency stops or heavy shock load. Admissible stops per life of reducer = 1,000 stops maximum.
³⁾ dB(A) Measured at 1 meter distance with 3000 RPM input.



"C" Series – Concentric Helical ServoFit® Modular System Selection Data



Part Number	Reducer Ratio i		Input RPM			Backlash arcmins $\Delta\phi$	Input Inertia J ₁ kgcm ²	Torsional Stiffness per arcmin C ₂		Output Torque					
			Maximum							Nominal ¹⁾		Acceleration		Peak ²⁾	
	Nom.	Exact	Continuous	n_{1DBH}	n_{1DBV}			n_{1ZB}	$M_{2N \leq 2000 \text{ RPM}}$		M_{2B}		M_{2PEAK}		
			Cyclic						in.lbs.	Nm	in.lbs.	Nm	in.lbs.	Nm	
C502 with MT TriAdapt® Motor Adapter <i>Continued</i> Noise Level ≤ 61 dB(A) ³⁾															
C502_0230 MT20	23.36	1495/64	3,400	3,000	4,500	12	4.2	188	21.2	7,086	800	7,529	850	11,464	1,294
C502_0230 MT30	23.36	1495/64	3,400	3,000	4,000	12	9.0	193	21.8	7,086	800	7,529	850	14,173	1,600
C502_0230 MT40	23.36	1495/64	3,000	3,000	3,500	12	13.0	197	22.2	7,086	800	7,529	850	14,173	1,600
C502_0230 MT50	23.36	1495/64	2,500	2,500	3,000	12	23.0	200	22.5	7,086	800	7,529	850	14,173	1,600
C502_0250 MT20	25.07	2407/96	3,400	3,000	4,500	12	3.5	190	21.4	6,561	741	8,149	920	11,796	1,332
C502_0250 MT30	25.07	2407/96	3,400	3,000	4,000	12	8.3	194	21.9	7,086	800	8,149	920	14,173	1,600
C502_0250 MT40	25.07	2407/96	3,000	3,000	3,500	12	12.3	198	22.3	7,086	800	8,149	920	14,173	1,600
C502_0250 MT50	25.07	2407/96	2,500	2,500	3,000	12	22.3	200	22.6	7,086	800	8,149	920	14,173	1,600
C502_0280 MT20	28.10	5395/192	3,400	3,000	4,500	12	3.5	192	21.7	7,086	800	7,529	850	13,219	1,492
C502_0280 MT30	28.10	5395/192	3,400	3,000	4,000	12	8.3	195	22.1	7,086	800	7,529	850	14,173	1,600
C502_0280 MT40	28.10	5395/192	3,000	3,000	3,500	12	12.3	198	22.4	7,086	800	7,529	850	14,173	1,600
C502_0280 MT50	28.10	5395/192	2,500	2,500	3,000	12	22.3	200	22.6	7,086	800	7,529	850	14,173	1,600
C502_0310 MT20	31.23	406/13	3,400	3,000	4,500	12	2.8	194	21.9	6,739	761	8,149	920	14,001	1,581
C502_0310 MT30	31.23	406/13	3,400	3,000	4,000	12	7.6	196	22.2	7,086	800	8,149	920	14,001	1,581
C502_0310 MT40	31.23	406/13	3,000	3,000	3,500	12	11.6	199	22.4	7,086	800	8,149	920	14,001	1,581
C502_0350 MT20	35.00	35/1	3,400	3,000	4,500	12	2.8	195	22.0	7,086	800	7,529	850	14,173	1,600
C502_0350 MT30	35.00	35/1	3,400	3,000	4,000	12	7.6	197	22.3	7,086	800	7,529	850	14,173	1,600
C502_0350 MT40	35.00	35/1	3,000	3,000	3,500	12	11.6	199	22.5	7,086	800	7,529	850	14,173	1,600
C502_0420 MT20	41.69	667/16	3,400	3,000	4,500	12	2.2	197	22.2	7,014	792	8,149	920	14,173	1,600
C502_0420 MT30	41.69	667/16	3,400	3,000	4,000	12	7.0	198	22.4	7,086	800	8,149	920	14,173	1,600
C502_0420 MT40	41.69	667/16	3,000	3,000	3,500	12	11.0	200	22.5	7,086	800	8,149	920	14,173	1,600
C502_0470 MT20	46.72	1495/32	3,400	3,000	4,500	12	2.2	198	22.3	7,086	800	7,529	850	14,173	1,600
C502_0470 MT30	46.72	1495/32	3,400	3,000	4,000	12	7.0	199	22.5	7,086	800	7,529	850	14,173	1,600
C502_0470 MT40	46.72	1495/32	3,000	3,000	3,500	12	11.0	200	22.6	7,086	800	7,529	850	14,173	1,600
C502_0500 MT20	49.82	1943/39	3,400	3,000	4,500	12	1.9	198	22.4	7,086	800	8,149	920	14,173	1,600
C502_0500 MT30	49.82	1943/39	3,400	3,000	4,000	12	6.7	199	22.5	7,086	800	8,149	920	14,173	1,600
C502_0500 MT40	49.82	1943/39	3,000	3,000	3,500	12	10.7	200	22.6	7,086	800	8,149	920	14,173	1,600
C502_0560 MT20	55.83	335/6	3,400	3,000	4,500	12	1.9	199	22.4	7,086	800	7,529	850	14,173	1,600
C502_0560 MT30	55.83	335/6	3,400	3,000	4,000	12	6.7	200	22.5	7,086	800	7,529	850	14,173	1,600
C502_0560 MT40	55.83	335/6	3,000	3,000	3,500	12	10.7	200	22.6	7,086	800	7,529	850	14,173	1,600
C502_0620 MT20	62.43	4495/72	3,400	3,000	4,500	12	1.7	199	22.5	6,325	714	7,590	857	10,212	1,153
C502_0620 MT30	62.43	4495/72	3,400	3,000	4,000	12	6.5	200	22.6	6,325	714	7,590	857	10,212	1,153
C502_0700 MT20	69.97	10075/144	3,400	3,000	4,500	12	1.7	199	22.5	7,086	800	7,529	850	11,444	1,292
C502_0700 MT30	69.97	10075/144	3,400	3,000	4,000	12	6.5	200	22.6	7,086	800	7,529	850	11,444	1,292
C503 with MT TriAdapt® Motor Adapter Noise Level ≤ 61 dB(A) ³⁾															
C503_0810 MT20	80.60	19343/240	3,400	3,000	4,500	12	1.6	200	22.6	7,086	800	8,149	920	10,228	1,155
C503_0900 MT20	90.32	8671/96	3,400	3,000	4,500	12	1.6	200	22.6	7,086	800	7,529	850	11,463	1,294
C503_1090 MT20	108.6	31291/288	3,400	3,000	4,500	12	1.5	200	22.6	7,086	800	7,529	850	13,218	1,492
C503_1350 MT20	135.3	406/3	3,400	3,000	4,500	12	1.5	201	22.6	7,086	800	7,529	850	14,173	1,600
C503_1810 MT20	180.6	8671/48	3,400	3,000	4,500	12	1.4	201	22.7	7,086	800	7,529	850	14,173	1,600
C503_2160 MT20	215.9	1943/9	3,400	3,000	4,500	12	1.4	201	22.7	7,086	800	7,529	850	14,173	1,600
C503_2710 MT20	270.5	58435/216	3,400	3,000	4,500	12	1.4	201	22.7	7,086	800	7,529	850	11,443	1,292

C

See Page 188 for Options and Part Number Configuration.



"C" Series – Concentric Helical ServoFit® Modular System Selection Data



Part Number	Reducer Ratio i		Input RPM			Backlash arcmins $\Delta\phi$	Input Inertia J ₁ kgcm ²	Torsional Stiffness per arcmin C ₂		Output Torque					
			Maximum							Nominal ¹⁾		Acceleration		Peak ²⁾	
	Nom.	Exact	n_{1DBH}	n_{1DBV}	n_{1ZB}			$M_{2N \leq 2000 \text{ RPM}}$		M_{2B}		M_{2PEAK}			
								in.lbs.	Nm	in.lbs.	Nm	in.lbs.	Nm		

C612 with MT TriAdapt® Motor Adapter *Continued Next Page*

Noise Level $\leq 61 \text{ dB(A)}$ ³⁾

C612_0042 MT30	4.184	2745/656	2,300	1,900	2,800	10	52.9	124	14.0	3,415	386	3,757	424	6,831	771
C612_0042 MT40	4.184	2745/656	2,300	1,900	2,800	10	56.9	217	24.5	5,522	623	5,522	623	6,902	779
C612_0042 MT50	4.184	2745/656	2,300	1,900	2,800	10	66.9	398	45.0	7,293	823	10,552	1,191	13,190	1,489
C612_0051 MT30	5.083	61/12	2,300	1,900	2,800	10	42.1	168	19.0	4,149	468	4,564	515	8,147	920
C612_0051 MT40	5.083	61/12	2,300	1,900	2,800	10	46.1	277	31.3	6,518	736	6,518	736	8,147	920
C612_0051 MT50	5.083	61/12	2,300	1,900	2,800	10	56.1	456	51.5	7,782	878	12,455	1,406	15,569	1,758
C612_0065 MT30	6.518	3233/496	2,700	2,300	3,300	10	31.7	238	26.8	5,320	601	5,852	661	10,064	1,136
C612_0065 MT40	6.518	3233/496	2,700	2,300	3,300	10	35.7	358	40.4	8,051	909	8,051	909	10,064	1,136
C612_0065 MT50	6.518	3233/496	2,500	2,300	3,000	10	45.7	518	58.5	8,454	954	14,282	1,612	19,232	2,171
C612_0071 MT30	7.111	64/9	2,300	1,900	2,800	10	38.4	265	29.9	5,804	655	6,385	721	11,398	1,287
C612_0071 MT40	7.111	64/9	2,300	1,900	2,800	10	42.4	386	43.6	8,703	983	9,118	1,029	11,398	1,287
C612_0071 MT50	7.111	64/9	2,300	1,900	2,800	10	52.4	536	60.6	8,703	983	12,224	1,380	21,780	2,459
C612_0082 MT30	8.190	1769/216	2,700	2,300	3,300	10	25.0	310	35.0	6,685	755	7,354	830	12,217	1,379
C612_0082 MT40	8.190	1769/216	2,700	2,300	3,300	10	29.0	430	48.5	9,123	1,030	9,773	1,103	12,217	1,379
C612_0082 MT50	8.190	1769/216	2,500	2,300	3,000	10	39.0	562	63.4	9,123	1,030	14,616	1,650	23,344	2,635
C612_0091 MT30	9.118	848/93	2,700	2,300	3,300	10	29.4	346	39.0	7,443	840	8,187	924	14,079	1,589
C612_0091 MT40	9.118	848/93	2,700	2,300	3,300	10	33.4	460	52.0	9,455	1,067	11,263	1,272	14,079	1,589
C612_0091 MT50	9.118	848/93	2,500	2,300	3,000	10	43.4	578	65.3	9,455	1,067	12,224	1,380	23,031	2,600
C612_0100 MT30	10.11	3721/368	3,000	2,600	3,500	10	20.7	379	42.8	8,253	932	9,079	1,025	14,489	1,636
C612_0100 MT40	10.11	3721/368	3,000	2,600	3,500	10	24.7	488	55.1	9,787	1,105	11,592	1,309	14,489	1,636
C612_0100 MT50	10.11	3721/368	2,500	2,500	3,000	10	34.7	591	66.8	9,787	1,105	14,616	1,650	25,688	2,900
C612_0115 MT30	11.46	928/81	2,700	2,300	3,300	10	23.6	418	47.2	9,352	1,056	10,287	1,161	17,090	1,929
C612_0115 MT40	11.46	928/81	2,700	2,300	3,300	10	27.6	517	58.4	10,203	1,152	12,224	1,380	17,090	1,929
C612_0115 MT50	11.46	928/81	2,500	2,300	3,000	10	37.6	605	68.3	10,203	1,152	12,224	1,380	23,031	2,600
C612_0125 MT30	12.58	2013/160	3,000	2,600	3,500	10	16.7	446	50.3	9,091	1,026	11,296	1,275	17,288	1,952
C612_0125 MT40	12.58	2013/160	3,000	2,600	3,500	10	20.7	537	60.6	10,526	1,188	13,830	1,561	17,288	1,952
C612_0125 MT50	12.58	2013/160	2,500	2,500	3,000	10	30.7	613	69.2	10,526	1,188	14,616	1,650	25,688	2,900
C612_0140 MT30	14.15	976/69	3,000	2,600	3,500	10	19.7	478	54.0	10,945	1,236	12,224	1,380	20,270	2,288
C612_0140 MT40	14.15	976/69	3,000	2,600	3,500	10	23.7	558	63.0	10,945	1,236	12,224	1,380	20,270	2,288
C612_0140 MT50	14.15	976/69	2,500	2,500	3,000	10	33.7	622	70.2	10,945	1,236	12,224	1,380	23,031	2,600
C612_0160 MT30	16.20	1037/64	3,200	2,900	4,000	10	13.3	511	57.7	9,634	1,088	14,549	1,642	21,206	2,394
C612_0160 MT40	16.20	1037/64	3,000	2,900	3,500	10	17.3	579	65.3	11,452	1,293	14,616	1,650	21,206	2,394
C612_0160 MT50	16.20	1037/64	2,500	2,500	3,000	10	27.3	630	71.1	11,452	1,293	14,616	1,650	25,688	2,900
C612_0175 MT30	17.60	88/5	3,000	2,600	3,500	10	16.1	529	59.7	11,515	1,300	12,224	1,380	23,031	2,600
C612_0175 MT40	17.60	88/5	3,000	2,600	3,500	10	20.1	590	66.6	11,515	1,300	12,224	1,380	23,031	2,600
C612_0175 MT50	17.60	88/5	2,500	2,500	3,000	10	30.1	634	71.6	11,515	1,300	12,224	1,380	23,031	2,600
C612_0195 MT30	19.61	549/28	3,200	2,900	4,000	10	11.4	550	62.1	9,917	1,120	14,616	1,650	24,644	2,782
C612_0195 MT40	19.61	549/28	3,000	2,900	3,500	10	15.4	602	67.9	12,204	1,378	14,616	1,650	24,644	2,782
C612_0195 MT50	19.61	549/28	2,500	2,500	3,000	10	25.4	638	72.0	12,204	1,378	14,616	1,650	24,644	2,782
C612_0230 MT30	22.67	68/3	3,200	2,900	4,000	10	12.9	573	64.7	11,515	1,300	12,224	1,380	23,031	2,600
C612_0230 MT40	22.67	68/3	3,000	2,900	3,500	10	16.9	615	69.4	11,515	1,300	12,224	1,380	23,031	2,600
C612_0230 MT50	22.67	68/3	2,500	2,500	3,000	10	26.9	643	72.6	11,515	1,300	12,224	1,380	23,031	2,600
C612_0250 MT30	24.93	5185/208	3,200	2,900	4,000	10	9.7	586	66.2	10,244	1,157	14,616	1,650	25,688	2,900
C612_0250 MT40	24.93	5185/208	3,000	2,900	3,500	10	13.7	622	70.2	12,844	1,450	14,616	1,650	25,688	2,900
C612_0250 MT50	24.93	5185/208	2,500	2,500	3,000	10	23.7	645	72.8	12,844	1,450	14,616	1,650	25,688	2,900
C612_0270 MT30	27.43	192/7	3,200	2,900	4,000	10	11.2	598	67.5	11,515	1,300	12,224	1,380	23,031	2,600
C612_0270 MT40	27.43	192/7	3,000	2,900	3,500	10	15.2	627	70.8	11,515	1,300	12,224	1,380	23,031	2,600
C612_0270 MT50	27.43	192/7	2,500	2,500	3,000	10	25.2	647	73.1	11,515	1,300	12,224	1,380	23,031	2,600
C612_0320 MT30	32.41	1037/32	3,200	2,900	4,000	10	8.4	613	69.2	10,679	1,206	14,616	1,650	25,688	2,900
C612_0320 MT40	32.41	1037/32	3,000	2,900	3,500	10	12.4	636	71.8	12,844	1,450	14,616	1,650	25,688	2,900
C612_0320 MT50	32.41	1037/32	2,500	2,500	3,000	10	22.4	650	73.4	12,844	1,450	14,616	1,650	25,688	2,900

Maximum Motor Shaft

Adapter	Diameter	Adapter	Diameter
MT10	19	MT40	48
MT20	24	MT50	60
MT30	38		

- ¹⁾ Maximum torque for continuous input RPM - horizontal output position.
²⁾ Maximum momentary torque for emergency stops or heavy shock load. Admissible stops per life of reducer = 1,000 stops maximum.
³⁾ dB(A) Measured at 1 meter distance with 3000 RPM input.



"C" Series – Concentric Helical ServoFit® Modular System Selection Data



Part Number	Reducer Ratio i		Input RPM			Backlash arcmins $\Delta\phi$	Input Inertia J ₁ kgcm ²	Torsional Stiffness per arcmin C ₂		Output Torque					
			Maximum							Nominal ¹⁾		Acceleration		Peak ²⁾	
	Nom.	Exact	n _{1DBH}	n _{1DBV}	n _{1ZB}			M _{2N} ≤ 2000 RPM		M _{2B}		M _{2PEAK}			
								Continuous	Cyclic	in.lbs.	Nm	in.lbs.	Nm	in.lbs.	Nm
C612 with MT TriAdapt® Motor Adapter <i>Continued</i> Noise Level ≤ 61 dB(A) ³⁾															
C612_0350 MT30	34.87	1360/39	3,200	2,900	4,000	10	9.5	619	69.9	11,515	1,300	12,224	1,380	23,031	2,600
C612_0350 MT40	34.87	1360/39	3,000	2,900	3,500	10	13.5	638	72.1	11,515	1,300	12,224	1,380	23,031	2,600
C612_0350 MT50	34.87	1360/39	2,500	2,500	3,000	10	23.5	651	73.5	11,515	1,300	12,224	1,380	23,031	2,600
C612_0390 MT30	39.40	1891/48	3,200	2,900	4,000	10	7.7	627	70.8	10,812	1,221	12,975	1,465	16,479	1,860
C612_0390 MT40	39.40	1891/48	3,000	2,900	3,500	10	11.7	642	72.5	10,812	1,221	12,975	1,465	16,479	1,860
C612_0450 MT30	45.33	136/3	3,200	2,900	4,000	10	8.3	634	71.6	11,515	1,300	12,224	1,380	23,031	2,600
C612_0450 MT40	45.33	136/3	3,000	2,900	3,500	10	12.3	646	72.9	11,515	1,300	12,224	1,380	23,031	2,600
C612_0450 MT50	45.33	136/3	2,500	2,500	3,000	10	22.3	653	73.8	11,515	1,300	12,224	1,380	23,031	2,600
C612_0550 MT30	55.11	496/9	3,200	2,900	4,000	10	7.6	641	72.4	11,515	1,300	12,224	1,380	23,031	2,600
C612_0550 MT40	55.11	496/9	3,000	2,900	3,500	10	11.6	649	73.3	11,515	1,300	12,224	1,380	23,031	2,600
C612_0690 MT30	68.89	620/9	3,200	2,900	4,000	10	7.1	647	73.0	11,515	1,300	12,224	1,380	23,031	2,600
C612_0690 MT40	68.89	620/9	3,000	2,900	3,500	10	11.1	652	73.6	11,515	1,300	12,224	1,380	23,031	2,600
C613 with MT TriAdapt® Motor Adapter Noise Level ≤ 61 dB(A) ³⁾															
C613_0490 MT30	49.28	31537/640	3,200	2,900	4,000	10	7.2	637	72.0	12,688	1,432	13,829	1,561	17,287	1,952
C613_0630 MT30	63.46	48739/768	3,200	2,900	4,000	10	6.9	645	72.8	12,844	1,450	14,616	1,650	21,204	2,394
C613_0760 MT20	75.81	53077/70	3,200	2,900	4,000	10	1.7	643	72.6	7,643	863	7,643	863	9,554	1,079
C613_0770 MT30	76.80	8601/112	3,200	2,900	4,000	10	6.8	649	73.2	12,844	1,450	14,616	1,650	24,642	2,782
C613_0880 MT20	87.64	3944/45	3,200	2,900	4,000	10	1.8	647	73.0	9,200	1,039	9,200	1,039	11,500	1,298
C613_0890 MT30	88.78	799/9	3,200	2,900	4,000	10	6.9	651	73.5	11,515	1,300	12,224	1,380	23,031	2,600
C613_0980 MT30	97.63	243695/2496	3,200	2,900	4,000	10	6.7	652	73.6	12,844	1,450	14,616	1,650	25,688	2,900
C613_1060 MT20	106.1	3712/35	3,200	2,900	4,000	10	1.7	650	73.4	10,692	1,207	10,692	1,207	13,365	1,509
C613_1070 MT30	107.4	752/7	3,200	2,900	4,000	10	6.8	653	73.7	11,515	1,300	12,224	1,380	23,031	2,600
C613_1270 MT30	126.9	48739/384	3,200	2,900	4,000	10	6.6	654	73.8	12,844	1,450	14,616	1,650	25,688	2,900
C613_1350 MT20	134.8	15776/117	3,200	2,900	4,000	10	1.6	653	73.7	11,515	1,300	12,224	1,380	16,132	1,821
C613_1370 MT30	136.6	15980/117	3,200	2,900	4,000	10	6.7	654	73.9	11,515	1,300	12,224	1,380	23,031	2,600
C613_1750 MT20	175.3	7888/45	3,200	2,900	4,000	10	1.5	655	73.9	11,515	1,300	12,224	1,380	19,846	2,240
C613_1780 MT30	177.6	1598/9	3,200	2,900	4,000	10	6.6	656	74.0	11,515	1,300	12,224	1,380	23,031	2,600
C613_2130 MT20	213.1	28768/135	3,200	2,900	4,000	10	1.5	655	74.0	11,515	1,300	12,224	1,380	23,031	2,600
C613_2660 MT20	266.4	7192/27	3,200	2,900	4,000	10	1.4	656	74.1	11,515	1,300	12,224	1,380	23,031	2,600
C712 with MT TriAdapt® Motor Adapter <i>Continued Next Page</i> Noise Level ≤ 67 dB(A) ³⁾															
C712_0043 MT30	4.259	477/112	2,200	1,900	2,600	10	101.8	139	15.7	3,476	392	3,824	432	6,953	785
C712_0043 MT40	4.259	477/112	2,200	1,900	2,600	10	105.8	256	28.9	5,899	666	5,899	666	7,374	832
C712_0043 MT50	4.259	477/112	2,200	1,900	2,600	10	115.8	532	60.1	11,272	1,273	11,272	1,273	14,090	1,591
C712_0053 MT30	5.311	1827/344	2,200	1,900	2,600	10	77.3	201	22.7	4,335	489	4,769	538	8,670	979
C712_0053 MT40	5.311	1827/344	2,200	1,900	2,600	10	81.3	352	39.8	7,120	804	7,120	804	8,900	1,005
C712_0053 MT50	5.311	1827/344	2,200	1,900	2,600	10	91.3	650	73.4	13,070	1,475	13,605	1,536	17,006	1,920
C712_0068 MT30	6.811	252/37	2,600	2,300	3,100	10	57.4	296	33.4	5,560	628	6,116	690	10,992	1,241
C712_0068 MT40	6.811	252/37	2,600	2,300	3,100	10	61.4	479	54.1	8,794	993	8,794	993	10,992	1,241
C712_0068 MT50	6.811	252/37	2,500	2,300	3,000	10	71.4	771	87.0	14,200	1,603	16,804	1,897	21,005	2,371
C712_0074 MT30	7.357	3480/473	2,200	1,900	2,600	10	70.9	330	37.2	6,005	678	6,606	746	12,011	1,356
C712_0074 MT40	7.357	3480/473	2,200	1,900	2,600	10	74.9	520	58.7	9,862	1,113	9,862	1,113	12,328	1,392
C712_0074 MT50	7.357	3480/473	2,200	1,900	2,600	10	84.9	804	90.8	14,569	1,645	18,846	2,128	23,557	2,659
C712_0085 MT30	8.490	4347/512	2,600	2,300	3,100	10	44.2	399	45.0	6,930	782	7,623	861	13,214	1,492
C712_0085 MT40	8.490	4347/512	2,600	2,300	3,100	10	48.2	598	67.5	10,571	1,193	10,571	1,193	13,214	1,492
C712_0085 MT50	8.490	4347/512	2,500	2,300	3,000	10	58.2	859	97.0	15,282	1,725	20,200	2,280	25,250	2,850

See Page 188 for Options and Part Number Configuration.



"C" Series – Concentric Helical ServoFit® Modular System Selection Data



Part Number	Reducer Ratio i		Input RPM			Backlash arcmins $\Delta\phi$	Input Inertia J ₁ kgcm ²	Torsional Stiffness per arcmin C ₂		Output Torque					
			Maximum					Nominal ¹⁾		Acceleration		Peak ²⁾			
	Nom.		Exact		M _{2N} ≤ 2000 RPM			M _{2B}		M _{2PEAK}					
	n_{1DBH}	n_{1DBV}	n_{1ZB}	in.lbs.	Nm			in.lbs.	Nm	in.lbs.	Nm	in.lbs.	Nm		
C712 with MT TriAdapt® Motor Adapter <i>Continued</i> Noise Level ≤ 67 dB(A) ³⁾															
C712_0094 MT30	9.435	3840/407	2,600	2,300	3,100	10	53.4	454	51.2	7,701	869	8,472	956	15,227	1,719
C712_0094 MT40	9.435	3840/407	2,600	2,300	3,100	10	57.4	653	73.7	12,182	1,375	12,182	1,375	15,227	1,719
C712_0094 MT50	9.435	3840/407	2,500	2,300	3,000	10	67.4	894	100.9	15,829	1,787	20,373	2,300	29,097	3,285
C712_0099 MT30	9.912	4599/464	2,900	2,600	3,400	10	37.5	480	54.2	8,091	913	8,900	1,005	15,052	1,699
C712_0099 MT40	9.912	4599/464	2,900	2,600	3,400	10	41.5	678	76.6	12,041	1,359	12,041	1,359	15,052	1,699
C712_0099 MT50	9.912	4599/464	2,500	2,500	3,000	10	51.5	909	102.6	16,091	1,817	23,010	2,598	28,762	3,247
C712_0120 MT30	11.76	1035/88	2,600	2,300	3,100	10	41.7	572	64.6	9,600	1,084	10,560	1,192	18,304	2,066
C712_0120 MT40	11.76	1035/88	2,600	2,300	3,100	10	45.7	761	85.9	14,644	1,653	14,644	1,653	18,304	2,066
C712_0120 MT50	11.76	1035/88	2,500	2,300	3,000	10	55.7	953	107.6	17,035	1,923	20,373	2,300	34,978	3,949
C712_0130 MT30	13.18	4851/368	2,900	2,600	3,400	10	27.6	633	71.4	10,760	1,215	11,836	1,336	18,890	2,133
C712_0130 MT40	13.18	4851/368	2,900	2,600	3,400	10	31.6	810	91.4	15,112	1,706	15,112	1,706	18,890	2,133
C712_0130 MT50	13.18	4851/368	2,500	2,500	3,000	10	41.6	977	110.3	17,696	1,998	24,448	2,760	36,097	4,075
C712_0135 MT30	13.73	4380/319	2,900	2,600	3,400	10	35.6	654	73.8	11,207	1,265	12,328	1,392	20,850	2,354
C712_0135 MT40	13.73	4380/319	2,900	2,600	3,400	10	39.6	826	93.3	16,680	1,883	16,680	1,883	20,850	2,354
C712_0135 MT50	13.73	4380/319	2,500	2,500	3,000	10	49.6	984	111.1	17,716	2,000	20,373	2,300	35,432	4,000
C712_0165 MT30	16.73	1071/64	3,100	2,900	3,600	10	21.1	751	84.8	12,091	1,365	15,025	1,696	22,994	2,596
C712_0165 MT40	16.73	1071/64	3,000	2,900	3,500	10	25.1	895	101.1	18,395	2,077	18,395	2,077	22,994	2,596
C712_0165 MT50	16.73	1071/64	2,500	2,500	3,000	10	35.1	1,014	114.5	19,160	2,163	24,448	2,760	42,518	4,800
C712_0185 MT30	18.26	420/23	2,900	2,600	3,400	10	26.5	790	89.2	14,906	1,683	16,396	1,851	26,169	2,954
C712_0185 MT40	18.26	420/23	2,900	2,600	3,400	10	30.5	921	103.9	17,716	2,000	20,373	2,300	26,169	2,954
C712_0185 MT50	18.26	420/23	2,500	2,500	3,000	10	40.5	1,025	115.7	17,716	2,000	20,373	2,300	35,432	4,000
C712_0210 MT30	20.67	1323/64	3,100	2,900	3,600	10	16.9	840	94.8	12,291	1,388	18,561	2,095	27,054	3,054
C712_0210 MT40	20.67	1323/64	3,000	2,900	3,500	10	20.9	952	107.5	20,559	2,321	21,643	2,443	27,054	3,054
C712_0210 MT50	20.67	1323/64	2,500	2,500	3,000	10	30.9	1,037	117.0	20,559	2,321	24,448	2,760	42,518	4,800
C712_0230 MT30	23.18	255/11	3,100	2,900	3,600	10	20.4	880	99.4	16,751	1,891	20,373	2,300	31,854	3,596
C712_0230 MT40	23.18	255/11	3,000	2,900	3,500	10	24.4	976	110.2	17,716	2,000	20,373	2,300	31,854	3,596
C712_0230 MT50	23.18	255/11	2,500	2,500	3,000	10	34.4	1,046	118.1	17,716	2,000	20,373	2,300	35,432	4,000
C712_0250 MT30	25.31	405/16	3,100	2,900	3,600	10	13.8	907	102.4	12,803	1,445	22,728	2,566	31,815	3,592
C712_0250 MT40	25.31	405/16	3,000	2,900	3,500	10	17.8	992	112.0	21,259	2,400	24,448	2,760	31,815	3,592
C712_0250 MT50	25.31	405/16	2,500	2,500	3,000	10	27.8	1,051	118.7	21,259	2,400	24,448	2,760	31,815	3,592
C712_0290 MT30	28.64	315/11	3,100	2,900	3,600	10	16.5	941	106.2	17,027	1,922	20,373	2,300	35,432	4,000
C712_0290 MT40	28.64	315/11	3,000	2,900	3,500	10	20.5	1,010	114.0	17,716	2,000	20,373	2,300	35,432	4,000
C712_0290 MT50	28.64	315/11	2,500	2,500	3,000	10	30.5	1,058	119.4	17,716	2,000	20,373	2,300	35,432	4,000
C712_0340 MT30	33.80	2163/64	3,100	2,900	3,600	10	10.9	977	110.3	13,188	1,489	24,448	2,760	39,811	4,494
C712_0340 MT40	33.80	2163/64	3,000	2,900	3,500	10	14.9	1,029	116.2	21,259	2,400	24,448	2,760	39,811	4,494
C712_0340 MT50	33.80	2163/64	2,500	2,500	3,000	10	24.9	1,065	120.2	21,259	2,400	24,448	2,760	39,811	4,494
C712_0350 MT30	35.07	2700/77	3,100	2,900	3,600	10	13.6	983	111.0	17,716	2,000	20,373	2,300	35,432	4,000
C712_0350 MT40	35.07	2700/77	3,000	2,900	3,500	10	17.6	1,033	116.6	17,716	2,000	20,373	2,300	35,432	4,000
C712_0350 MT50	35.07	2700/77	2,500	2,500	3,000	10	27.6	1,066	120.3	17,716	2,000	20,373	2,300	35,432	4,000
C712_0410 MT30	41.02	2625/64	3,100	2,900	3,600	10	9.5	1,008	113.8	13,517	1,526	22,265	2,514	37,108	4,189
C712_0410 MT40	41.02	2625/64	3,000	2,900	3,500	10	13.5	1,046	118.1	18,554	2,095	22,265	2,514	37,108	4,189
C712_0410 MT50	41.02	2625/64	2,500	2,500	3,000	10	23.5	1,070	120.8	18,554	2,095	22,265	2,514	37,108	4,189
C712_0470 MT30	46.82	515/11	3,100	2,900	3,600	10	10.7	1,024	115.7	17,716	2,000	20,373	2,300	35,432	4,000
C712_0470 MT40	46.82	515/11	3,000	2,900	3,500	10	14.7	1,054	119.0	17,716	2,000	20,373	2,300	35,432	4,000
C712_0470 MT50	46.82	515/11	2,500	2,500	3,000	10	24.7	1,073	121.1	17,716	2,000	20,373	2,300	35,432	4,000
C712_0570 MT30	56.82	625/11	3,100	2,900	3,600	10	9.4	1,042	117.7	17,716	2,000	20,373	2,300	35,432	4,000
C712_0570 MT40	56.82	625/11	3,000	2,900	3,500	10	13.4	1,063	120.0	17,716	2,000	20,373	2,300	35,432	4,000
C712_0570 MT50	56.82	625/11	2,500	2,500	3,000	10	23.4	1,076	121.5	17,716	2,000	20,373	2,300	35,432	4,000
C712_0700 MT30	69.55	765/11	3,100	2,900	3,600	10	8.3	1,055	119.1	17,716	2,000	20,373	2,300	29,091	3,284
C712_0700 MT40	69.55	765/11	3,000	2,900	3,500	10	12.3	1,069	120.7	17,716	2,000	20,373	2,300	29,091	3,284

Maximum Motor Shaft			
Adapter	Diameter	Adapter	Diameter
MT10	19	MT40	48
MT20	24	MT50	60
MT30	38		

¹⁾ Maximum torque for continuous input RPM - horizontal output position.
²⁾ Maximum momentary torque for emergency stops or heavy shock load. Admissible stops per life of reducer = 1,000 stops maximum.
³⁾ dB(A) Measured at 1 meter distance with 3000 RPM input.



"C" Series – Concentric Helical ServoFit® Modular System Selection Data



Part Number	Reducer Ratio i		Input RPM			Backlash arcmins $\Delta\phi$	Input Inertia J ₁ kgcm ²	Torsional Stiffness per arcmin C ₂		Output Torque					
			Maximum							Nominal ¹⁾		Acceleration		Peak ²⁾	
	Nom.		Exact		Continuous			Cyclic	M _{2N} ≤ 2000 RPM		M _{2B}		M _{2PEAK}		
	n _{1DBH}	n _{1DBV}	n _{1ZB}		in.lbs.			Nm	in.lbs.	Nm	in.lbs.	Nm	in.lbs.	Nm	
C713 with MT TriAdapt® Motor Adapter															
Noise Level ≤ 67 dB(A) ³⁾															
C713_0510 MT40	50.85	18711/368	3,000	2,900	3,500	10	13.1	1,058	119.5	21,259	2,400	24,448	2,760	36,099	4,075
C713_0650 MT40	64.55	4131/64	3,000	2,900	3,500	10	12.6	1,067	120.5	21,259	2,400	24,448	2,760	42,518	4,800
C713_0800 MT40	79.73	5103/64	3,000	2,900	3,500	10	12.4	1,072	121.1	21,259	2,400	24,448	2,760	42,518	4,800
C713_0810 MT30	80.97	20727/256	3,100	2,900	3,600	10	7.2	1,062	119.9	17,492	1,975	21,642	2,443	27,052	3,054
C713_0890 MT40	89.42	6885/77	3,000	2,900	3,500	10	12.6	1,074	121.3	17,716	2,000	20,373	2,300	35,432	4,000
C713_0980 MT40	97.63	10935/112	3,000	2,900	3,500	10	12.2	1,076	121.4	21,259	2,400	24,448	2,760	31,816	3,592
C713_0990 MT30	99.14	6345/64	3,100	2,900	3,600	10	7.0	1,069	120.7	18,518	2,090	24,448	2,760	31,812	3,591
C713_1100 MT40	110.5	1215/11	3,000	2,900	3,500	10	12.3	1,077	121.6	17,716	2,000	20,373	2,300	35,432	4,000
C713_1300 MT40	130.4	8343/64	3,000	2,900	3,500	10	12.0	1,078	121.8	21,259	2,400	24,448	2,760	39,812	4,494
C713_1320 MT30	132.4	33887/256	3,100	2,900	3,600	10	6.8	1,075	121.3	19,575	2,210	24,448	2,760	39,807	4,494
C713_1350 MT40	135.3	72900/539	3,000	2,900	3,500	10	12.1	1,079	121.8	17,716	2,000	20,373	2,300	35,432	4,000
C713_1370 MT30	137.3	10575/77	3,100	2,900	3,600	10	7.0	1,075	121.4	17,716	2,000	20,373	2,300	35,432	4,000
C713_1810 MT40	180.6	13905/77	3,000	2,900	3,500	10	11.9	1,080	122.0	17,716	2,000	20,373	2,300	35,432	4,000
C713_1830 MT30	183.4	24205/132	3,100	2,900	3,600	10	6.8	1,078	121.7	17,716	2,000	20,373	2,300	35,432	4,000
C713_2190 MT40	219.2	16875/77	3,000	2,900	3,500	10	11.9	1,081	122.0	17,716	2,000	20,373	2,300	35,432	4,000
C713_2230 MT30	222.5	29375/132	3,100	2,900	3,600	10	6.7	1,079	121.9	17,716	2,000	20,373	2,300	35,432	4,000
C812 with MT TriAdapt® Motor Adapter															
Continued Next Page															
Noise Level ≤ 67 dB(A) ³⁾															
C812_0042 MT50	4.225	1711/405	2,100	1,800	2,500	10	264.3	573	64.7	11,756	1,327	11,756	1,327	14,695	1,659
C812_0054 MT50	5.387	1239/230	2,100	1,800	2,500	10	195.5	728	82.2	14,454	1,632	14,454	1,632	18,067	2,040
C812_0067 MT50	6.670	767/115	2,500	2,200	2,800	10	151.9	858	96.9	17,377	1,962	17,377	1,962	21,721	2,452
C812_0073 MT50	7.304	168/23	2,100	1,800	2,500	10	179.0	1,138	128.4	19,597	2,212	19,597	2,212	24,496	2,765
C812_0085 MT50	8.472	1652/195	2,500	2,200	2,800	10	113.4	983	111.0	21,179	2,391	21,179	2,391	26,474	2,989
C812_0090 MT50	9.043	208/23	2,500	2,200	2,800	10	141.2	1,305	147.3	23,559	2,660	23,559	2,660	29,448	3,325
C812_0100 MT50	10.15	944/93	2,500	2,400	3,000	10	93.8	1,059	119.6	24,585	2,776	24,585	2,776	30,732	3,469
C812_0115 MT50	11.49	448/39	2,500	2,200	2,800	10	106.8	1,458	164.7	27,458	3,100	28,716	3,242	35,895	4,052
C812_0125 MT40	12.75	5546/435	2,700	2,400	3,200	10	63.5	902	101.8	15,488	1,748	15,488	1,748	19,360	2,186
C812_0125 MT50	12.75	5546/435	2,500	2,400	3,000	10	73.5	1,133	127.9	28,429	3,209	29,596	3,341	36,994	4,176
C812_0140 MT50	13.76	1280/93	2,500	2,400	3,000	10	89.2	1,548	174.8	29,164	3,292	33,334	3,763	41,667	4,704
C812_0170 MT40	17.10	1180/69	2,900	2,700	3,400	10	45.2	1,041	117.5	19,605	2,213	19,605	2,213	24,506	2,767
C812_0170 MT50	17.10	1180/69	2,500	2,500	3,000	10	55.2	1,197	135.1	31,353	3,540	37,463	4,229	46,829	5,287
C812_0175 MT40	17.29	1504/87	2,700	2,400	3,200	10	60.6	1,360	153.6	21,001	2,371	21,001	2,371	26,251	2,964
C812_0175 MT50	17.29	1504/87	2,500	2,400	3,000	10	70.6	1,633	184.4	31,466	3,552	36,672	4,140	50,163	5,663
C812_0200 MT40	20.26	6077/300	2,900	2,700	3,400	10	37.1	1,102	124.4	22,426	2,532	22,426	2,532	28,032	3,165
C812_0200 MT50	20.26	6077/300	2,500	2,500	3,000	10	47.1	1,222	137.9	33,174	3,745	42,518	4,800	53,566	6,047
C812_0230 MT40	23.19	1600/69	2,900	2,700	3,400	10	43.6	1,527	172.4	26,583	3,001	26,583	3,001	33,229	3,751
C812_0230 MT50	23.19	1600/69	2,500	2,500	3,000	10	53.6	1,705	192.4	31,889	3,600	36,672	4,140	63,497	7,168
C812_0260 MT40	26.06	3127/120	2,900	2,700	3,400	10	28.3	1,169	131.9	27,158	3,066	27,283	3,080	34,103	3,850
C812_0260 MT50	26.06	3127/120	2,500	2,500	3,000	10	38.3	1,247	140.8	36,079	4,073	42,518	4,800	65,167	7,357
C812_0270 MT40	27.47	412/15	2,900	2,700	3,400	10	35.9	1,597	180.3	30,408	3,433	30,408	3,433	38,010	4,291
C812_0270 MT50	27.47	412/15	2,500	2,500	3,000	10	45.9	1,732	195.5	31,889	3,600	36,672	4,140	63,778	7,200
C812_0340 MT40	33.59	2183/65	2,900	2,700	3,400	10	22.1	1,213	137.0	28,022	3,163	33,261	3,755	41,577	4,694
C812_0340 MT50	33.59	2183/65	2,500	2,500	3,000	10	32.1	1,263	142.6	37,204	4,200	42,518	4,800	74,407	8,400
C812_0350 MT40	35.33	106/3	2,900	2,700	3,400	10	27.6	1,673	188.9	31,889	3,600	36,672	4,140	46,242	5,220
C812_0350 MT50	35.33	106/3	2,500	2,500	3,000	10	37.6	1,760	198.7	31,889	3,600	36,672	4,140	63,778	7,200
C812_0400 MT40	39.94	2596/65	2,900	2,700	3,400	10	18.9	1,234	139.4	28,769	3,248	38,126	4,304	47,658	5,380
C812_0400 MT50	39.94	2596/65	2,500	2,500	3,000	10	28.9	1,271	143.4	33,527	3,785	38,126	4,304	47,658	5,380



See Page 188 for Options and Part Number Configuration.



"C" Series – Concentric Helical ServoFit® Modular System Selection Data



Part Number	Reducer Ratio i		Input RPM			Backlash arcmins $\Delta\phi$	Input Inertia J ₁ kgcm ²	Torsional Stiffness per arcmin C ₂		Output Torque					
			Maximum							Nominal ¹⁾		Acceleration		Peak ²⁾	
	Nom.	Exact	Continuous		Cyclic			M _{2N} ≤ 2000 RPM		M _{2B}		M _{2PEAK}			
			n _{1DBH}	n _{1DBV}				n _{1ZB}	in.lbs.	Nm	in.lbs.	Nm	in.lbs.	Nm	
C812 with MT TriAdapt® Motor Adapter <i>Continued</i>										Noise Level ≤ 67 dB(A) ³⁾					
C812_0460 MT40	45.54	592/13	2,900	2,700	3,400	10	21.7	1,723	194.5	31,889	3,600	36,672	4,140	56,374	6,364
C812_0460 MT50	45.54	592/13	2,500	2,500	3,000	10	31.7	1,777	200.6	31,889	3,600	36,672	4,140	63,778	7,200
C812_0540 MT40	54.15	704/13	2,900	2,700	3,400	10	18.6	1,746	197.1	31,889	3,600	36,672	4,140	63,778	7,200
C812_0540 MT50	54.15	704/13	2,500	2,500	3,000	10	28.6	1,785	201.5	31,889	3,600	36,672	4,140	63,778	7,200
C812_0690 MT40	68.89	620/9	2,900	2,700	3,400	10	15.6	1,767	199.5	31,889	3,600	36,672	4,140	63,778	7,200
C812_0690 MT50	68.89	620/9	2,500	2,500	3,000	10	25.6	1,792	202.3	31,889	3,600	36,672	4,140	63,778	7,200
C813 with MT TriAdapt® Motor Adapter										Noise Level ≤ 67 dB(A) ³⁾					
C813_0490 MT40	49.18	49914/1015	2,900	2,700	3,400	10	15.2	1,734	195.7	29,597	3,341	29,597	3,341	36,997	4,177
C813_0660 MT40	65.96	10620/161	2,900	2,700	3,400	10	14.0	1,764	199.2	32,936	3,718	37,466	4,230	46,832	5,287
C813_0780 MT40	78.13	54693/700	2,900	2,700	3,400	10	13.4	1,775	200.4	34,401	3,884	42,518	4,800	53,567	6,047
C813_0790 MT30	79.34	285619/3600	2,900	2,700	3,400	10	8.3	1,747	197.2	20,953	2,365	22,424	2,531	28,029	3,164
C813_0890 MT40	89.44	14400/161	2,900	2,700	3,400	10	13.9	1,782	201.2	31,889	3,600	36,672	4,140	63,501	7,169
C813_0910 MT30	90.82	18800/207	2,900	2,700	3,400	10	8.7	1,760	198.7	24,905	2,812	26,582	3,001	33,227	3,751
C813_1010 MT40	100.5	28143/280	2,900	2,700	3,400	10	12.9	1,786	201.7	36,202	4,087	42,518	4,800	65,171	7,357
C813_1060 MT40	105.9	3708/35	2,900	2,700	3,400	10	13.4	1,788	201.9	31,889	3,600	36,672	4,140	63,778	7,200
C813_1080 MT30	107.6	4841/45	2,900	2,700	3,400	10	8.2	1,772	200.1	28,411	3,207	30,405	3,432	38,006	4,291
C813_1300 MT40	129.5	58941/455	2,900	2,700	3,400	10	12.4	1,793	202.4	37,204	4,200	42,518	4,800	74,407	8,400
C813_1360 MT40	136.3	954/7	2,900	2,700	3,400	10	12.8	1,794	202.6	31,889	3,600	36,672	4,140	63,778	7,200
C813_1380 MT30	138.4	2491/18	2,900	2,700	3,400	10	7.6	1,784	201.5	29,899	3,375	36,672	4,140	46,238	5,220
C813_1760 MT40	175.6	15984/91	2,900	2,700	3,400	10	12.4	1,798	203.0	31,889	3,600	36,672	4,140	63,778	7,200
C813_1780 MT30	178.4	6956/39	2,900	2,700	3,400	10	7.3	1,792	202.3	31,543	3,561	36,672	4,140	56,370	6,364
C813_2090 MT40	208.9	19008/91	2,900	2,700	3,400	10	12.2	1,800	203.2	31,889	3,600	36,672	4,140	63,778	7,200
C813_2120 MT30	212.1	8272/39	2,900	2,700	3,400	10	7.1	1,795	202.7	31,889	3,600	36,672	4,140	63,778	7,200
C813_2660 MT40	265.7	1860/7	2,900	2,700	3,400	10	12.0	1,801	203.3	31,889	3,600	36,672	4,140	63,778	7,200
C813_2700 MT30	269.8	7285/27	2,900	2,700	3,400	10	6.9	1,799	203.0	31,889	3,600	36,672	4,140	63,778	7,200
C912 with MT TriAdapt® Motor Adapter										Noise Level ≤ 73 dB(A) ³⁾					
C912_0165 MT50	16.5	5795/352	2,500	2,500	3,000	10	101.5	2,020	228.0	37,713	4,258	37,713	4,258	47,141	5,322
C912_0200 MT50	20.2	2257/112	2,500	2,500	3,000	10	79.6	2,110	238.2	44,280	4,999	44,280	4,999	55,349	6,249
C912_0230 MT50	23.4	6175/264	2,500	2,500	3,000	10	96.8	3,134	353.8	53,148	6,000	53,581	6,049	66,977	7,561
C912_0250 MT50	25.3	6893/272	2,500	2,500	3,000	10	61.5	2,183	246.4	53,014	5,985	53,014	5,985	66,268	7,481
C912_0290 MT50	28.6	2405/84	2,500	2,500	3,000	10	76.4	3,240	365.8	53,148	6,000	57,577	6,500	78,638	8,878
C912_0320 MT50	32.1	3599/112	2,500	2,500	3,000	10	48.0	2,232	252.0	55,803	6,300	63,801	7,203	79,751	9,003
C912_0360 MT50	36.0	7345/204	2,500	2,500	3,000	10	59.6	3,324	375.3	53,148	6,000	57,577	6,500	94,151	10,629
C912_0390 MT50	39.3	4087/104	2,500	2,500	3,000	10	39.9	2,260	255.2	53,230	6,009	63,876	7,211	92,963	10,495
C912_0460 MT50	45.7	3835/84	2,500	2,500	3,000	10	46.8	3,381	381.7	53,148	6,000	57,577	6,500	106,296	12,000
C912_0560 MT50	55.8	335/6	2,500	2,500	3,000	10	39.0	3,413	385.3	53,148	6,000	57,577	6,500	106,296	12,000
C912_0700 MT50	70.0	10075/144	2,500	2,500	3,000	10	32.8	3,436	387.9	53,148	6,000	57,577	6,500	82,414	9,304

Maximum Motor Shaft			
Adapter	Diameter	Adapter	Diameter
MT10	19	MT40	48
MT20	24	MT50	60
MT30	38		

¹⁾ Maximum torque for continuous input RPM - horizontal output position.
²⁾ Maximum momentary torque for emergency stops or heavy shock load. Admissible stops per life of reducer = 1,000 stops maximum.
³⁾ dB(A) Measured at 1 meter distance with 3000 RPM input.



"C" Series – Concentric Helical ServoFit® Modular System Selection Data



Part Number	Reducer Ratio i		Input RPM			Backlash arcmins $\Delta\phi$	Input Inertia J ₁ kgcm ²	Torsional Stiffness per arcmin C ₂		Output Torque					
			Maximum							Nominal ¹⁾		Acceleration		Peak ²⁾	
	Nom.	Exact	n _{1DBH}	n _{1DBV}	n _{1ZB}			M _{2N ≤ 2000 RPM}		M _{2B}		M _{2PEAK}			
								in.lbs.	Nm	in.lbs.	Nm	in.lbs.	Nm		
C913 with MT TriAdapt® Motor Adapter										Noise Level ≤ 73 dB(A) ³⁾					
C913_0780 MT40	77.7	60939/784	2,800	2,600	3,200	10	15.8	3,374	380.9	39,232	4,429	44,280	4,999	55,351	6,249
C913_0900 MT40	90.2	55575/616	2,800	2,600	3,200	10	17.0	3,400	383.8	52,907	5,973	53,584	6,049	66,979	7,561
C913_1100 MT40	110.4	21645/196	2,800	2,600	3,200	10	15.6	3,426	386.7	53,148	6,000	57,577	6,500	78,641	8,878
C913_1390 MT40	138.9	66105/476	2,800	2,600	3,200	10	14.5	3,445	388.9	53,148	6,000	57,577	6,500	94,154	10,629
C913_1760 MT40	176.1	34515/196	2,800	2,600	3,200	10	13.6	3,458	390.3	53,148	6,000	57,577	6,500	106,296	12,000
C913_2150 MT40	215.4	3015/14	2,800	2,600	3,200	10	13.1	3,464	391.1	53,148	6,000	57,577	6,500	106,296	12,000



See Page 188 for Options and Part Number Configuration.

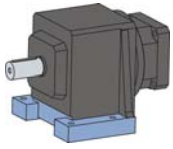

ServoFit® "C" Series – Concentric Helical Foot Mount – "N" Housing Dimensional Data

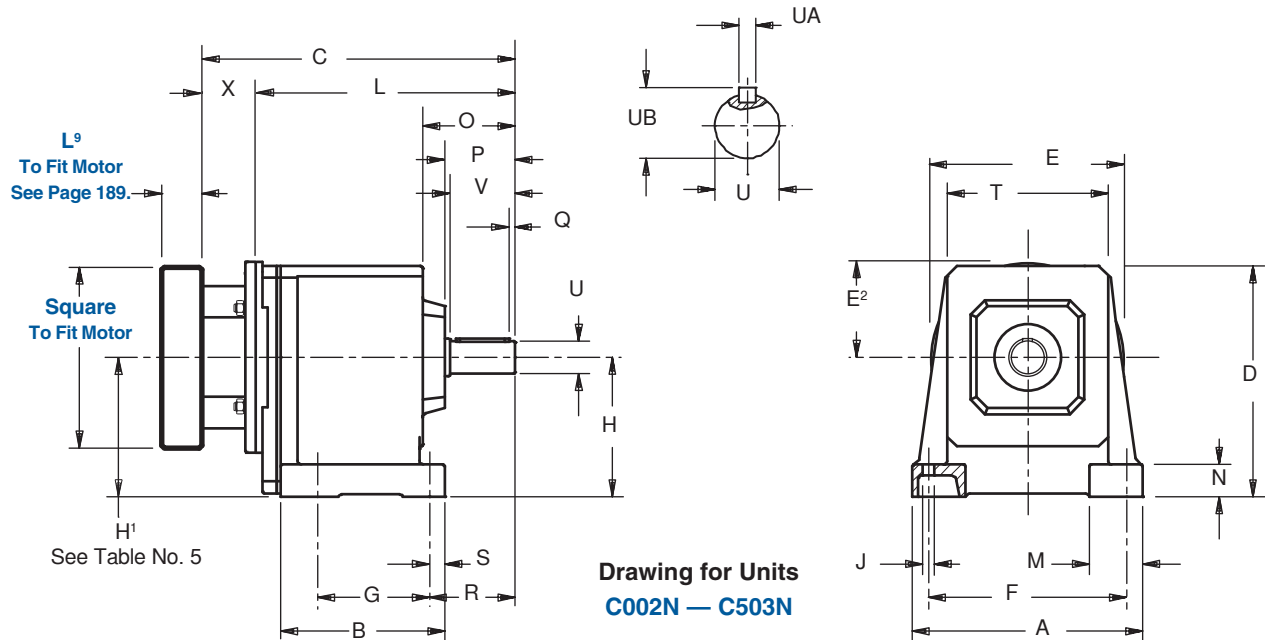

Table No. 1 "C" Series – Foot Mounting Unit Dimensions (mm) – "N" Housing Style

Base Module	A	B	D	F	G	H	J	M	N	O	P	Q	R	S	T	V	Z ¹
C002	132	95	144	110	62	82	7	35	20	57	44	3	55	11	92	40	—
C102/C103	176	118	177	150	70	102	9	42	25	69	54	5	67	13	124	50	—
C202/C203	200	135	195	170	85	115 ¹⁾	11	50	30	86	65	5	79	14	138	60	—
C302/C303	215	154	215	185	105	130 ¹⁾	11	50	30	85	65	5	79	14	150	60	—
C402/C403	255	180	245	220	110	145	14	60	35	106	86	5	105	19	175	80	—
C502/C503	290	197	290	245	130	170	18	70	40	107	86	5	108	22	192	80	—
C612/C613	300	265	315	245	215	200 ¹⁾	18	75	40	153	106	5	130	25	225	100	367
C712/C713	365	285	375	300	235	235 ¹⁾	18	90	50	185	127	5	163	25	265	120	436
C812/C813	435	360	450	340	300	290	22	95	55	218	148	5	190	29	310	140	511
C912/C913	510	410	530	400	340	340	26	110	60	256	178	5	222	34	365	170	600

¹⁾ See Table No. 5

Table No. 2 Metric output available on request

Base Module	Standard Shaft - inches			Optional Shaft - mm		
	U	UA	UB	U	UA	UB
C002	.750 _{h6}	3/16 × 3/16 × 17/32	.83	20 _{k6}	A6x6x32	22.5
C102/C103	1.000 _{h6}	1/4 × 1/4 × 19/16	1.11	25 _{k6}	A8x7x40	28
C202/C203	1.250 _{h6}	1/4 × 1/4 × 115/16	1.36	30 _{k6}	A8x7X50	33
C302/C303	1.250 _{h6}	1/4 × 1/4 × 115/16	1.36	30 _{k6}	A8x7X50	33
C402/C403	1.625 _{h6}	3/8 × 3/8 × 27/8	1.79	40 _{k6}	A12x8X70	43
C502/C503	1.625 _{h6}	3/8 × 3/8 × 27/8	1.79	40 _{k6}	A12x8X70	43
C612/C613	2.125 _{h6}	1/2 × 1/2 × 35/32	2.35	50 _{k6}	A14x9x90	53.5
C712/C713	2.375 _{h6}	5/8 × 5/8 × 315/16	2.65	60 _{m6}	A18x11x100	64
C812/C813	2.875 _{h6}	3/4 × 3/4 × 451/16	3.21	70 _{m6}	A20x12x125	74.5
C912/C913	3.625 _{h6}	7/8 × 7/8 × 51/2	4.01	90 _{m6}	A25x14x140	95

Table No. 3 Motor Adapter Dimensions (mm)

Motor Adapter	Motor Shaft D ⁶ Max. ¹⁾	Thickness ²⁾ L ⁹ Min.	E	E ²	X	Wt. lbs.
MT10	19	21	140	70	40	5
MT20	24	24	160	80	50	8
MT30	38	25	200	100	60	12
MT40	48	33	250	125	89	18
MT50	60	43	300	150	81.5	16

Part No. Example

Foot Mounting with TriAdapt® Motor Adapter
C302N0620 MT10

¹⁾ If an adapter bushing is required it will be supplied as a component of the motor mounting plate.

²⁾ Motor plate maximum thickness (L⁹) will vary with motor shaft length but will not be less than shown.

For approximate weight, add adapter weight from Table 3 and base module weight from Table 4.



ServoFit "C" Series – Concentric Helical Foot Mount – "N" Housing

Dimensional Data

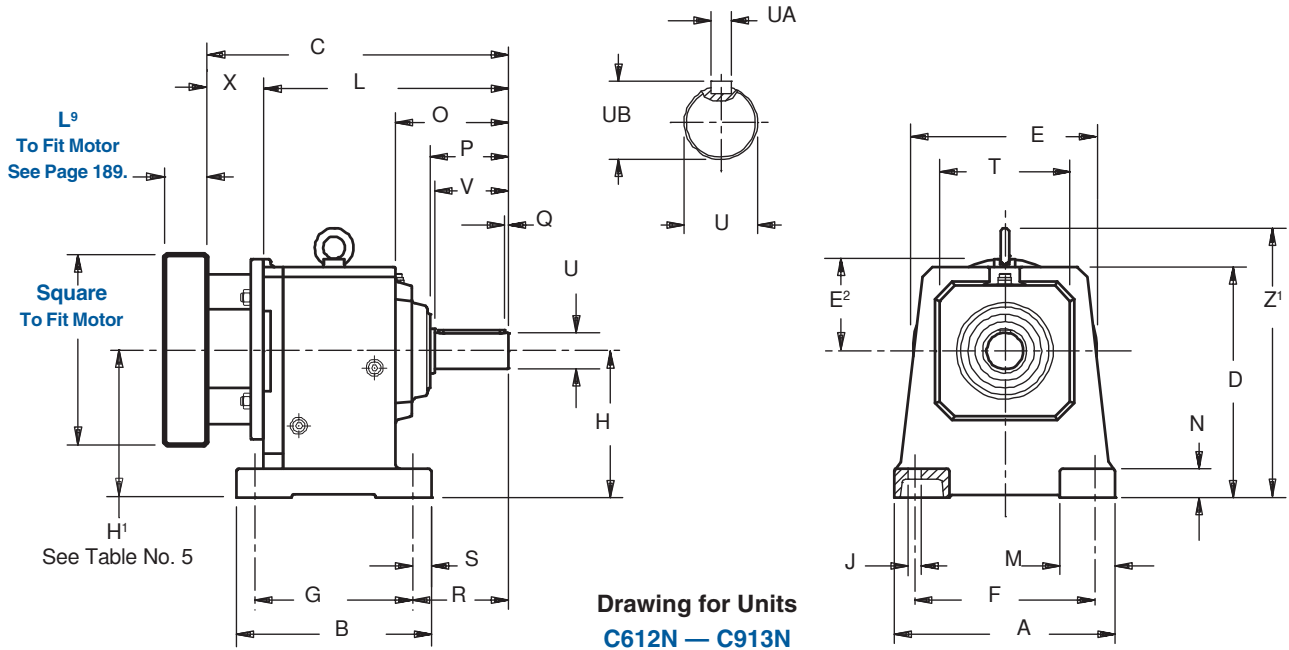

Table No. 4

"C" Series – Foot Mounting Unit Dimensions (mm) – "N" Housing Style

Base Module	MT10		MT20		MT30		MT40		MT50		Approx. Wt.(lbs.)
	C	L	C	L	C	L	C	L	C	L	
C002	194	154	208	158	—	—	—	—	—	—	18
C102	227	187	241	191	253	193	—	—	—	—	29
C103	264	224	—	—	—	—	—	—	—	—	34
C202	255	215	269	219	281	221	—	—	—	—	38
C203 ¹⁾	292	252	312	262	—	—	—	—	—	—	45
C302	—	—	288	238	300	240	332	243	—	—	49
C303 ¹⁾	311	271	331	281	—	—	—	—	—	—	56
C402	—	—	335.5	285.5	347.5	287.5	379.5	290.5	—	—	71
C403	—	—	378.5	328.5	—	—	—	—	—	—	78
C502	—	—	357	307	369	309	401	312	407.5	326	95
C503	—	—	400	350	—	—	—	—	—	—	111
C612 ¹⁾	—	—	—	—	393	333	425	336	430.5	349	115
C613 ¹⁾	—	—	425	375	455	395	—	—	—	—	159
C712	—	—	—	—	446	386	477	388	482.5	401	199
C713 ¹⁾	—	—	—	—	507	447	548	459	—	—	221
C812	—	—	—	—	—	—	544	455	549.5	468	322
C813	—	—	—	—	574	514	615	526	—	—	342
C912	—	—	—	—	—	—	—	—	616.5	535	596
C913	—	—	—	—	—	—	682	593	—	—	678

¹⁾ See Table No. 5

Table No. 5

"C" Series – Input Dimension

Base Module	MT20	MT30	MT40	MT50
C203	H ¹	—	—	—
C303	93	—	—	—
C612	—	193	193	193
C613	—	—	193	—
C713	—	—	254	—

Units shown in Table 5 do not have a concentric input and output.

See Page 188 for Options and Part Number Configuration.

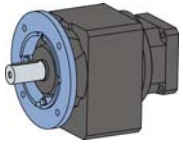

ServoFit® "C" Series – Concentric Helical Round Flange – "F" Housing

Dimensional Data

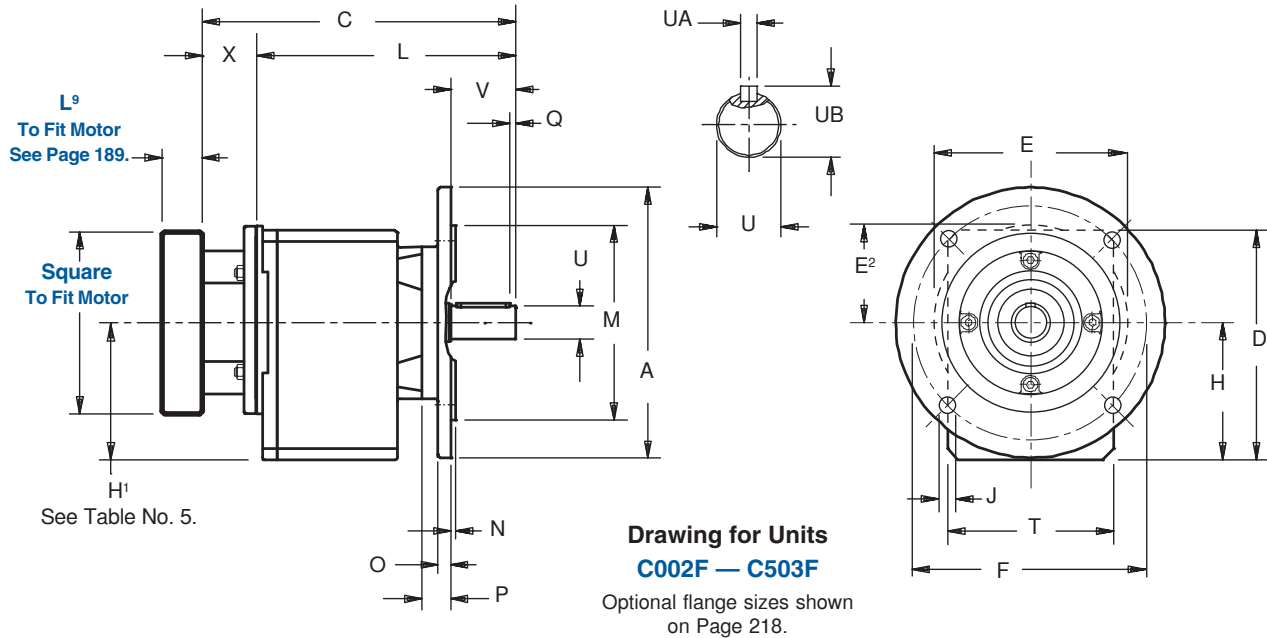

Table No. 1 "C" Series – Round Flange Unit Dimensions (mm) – "F" Housing Style

Base Module	A	D	F	H	J	M	N	O	P	Q	T	V	Z ¹
C002	160	141	130	79	9	110 _{h6}	3	10	18	3	97	40	—
C102/C103	200	175	165	100	11	130 _{h6}	3.5	12	21	5	130	50	—
C202/C203	200	192	165	112 ¹⁾	11	130 _{h6}	3.5	12	27	5	142	60	—
C302/C303	250	212	215	127 ¹⁾	14	180 _{h6}	4	12	27	5	154	60	—
C402/C403	250	242.5	215	142.5	14	180 _{h6}	4	14	28	5	178	80	—
C502/C503	300	286	265	166	14	230 _{h6}	4	16	29	5	195	80	—
C612/C613	300	310	265	195 ¹⁾	14	230 _{h6}	4	17	36	5	225	100	362
C712/C713	350	371	300	231 ¹⁾	18	250 _{h6}	5	18	44	5	265	120	432
C812/C813	400	445	350	285	18	300 _{h6}	5	20	45	5	310	140	506
C912/C913	450	524	400*	334	18	350 _{h6}	5	23	50	5	365	170	594

¹⁾ See Table No. 5

* C913 has 8 mounting holes (located 22.5° from horizontal) in the output flange instead of 4 as shown in the drawing.

Table No. 2 Metric output available on request

Base Module	Standard Shaft - inches			Optional Shaft - mm		
	U	UA	UB	U	UA	UB
C002	.750 _{h6}	3/16 × 3/16 × 1 ⁷ / ₃₂	.83	20 _{k6}	A6x6x32	22.5
C102/C103	1.000 _{h6}	1/4 × 1/4 × 1 ⁹ / ₁₆	1.11	25 _{k6}	A8x7x40	28
C202/C203	1.250 _{h6}	1/4 × 1/4 × 1 ¹⁵ / ₁₆	1.36	30 _{k6}	A8x7X50	33
C302/C303	1.250 _{h6}	1/4 × 1/4 × 1 ¹⁵ / ₁₆	1.36	30 _{k6}	A8x7X50	33
C402/C403	1.625 _{h6}	3/8 × 3/8 × 2 ⁷ / ₈	1.79	40 _{k6}	A12x8X70	43
C502/C503	1.625 _{h6}	3/8 × 3/8 × 2 ⁷ / ₈	1.79	40 _{k6}	A12x8X70	43
C612/C613	2.125 _{h6}	1/2 × 1/2 × 3 ⁵ / ₃₂	2.35	50 _{k6}	A14x9x90	53.5
C712/C713	2.375 _{h6}	5/8 × 5/8 × 3 ¹⁵ / ₁₆	2.65	60 _{m6}	A18x11x100	64
C812/C813	2.875 _{h6}	3/4 × 3/4 × 4 ⁵ / ₁₆	3.21	70 _{m6}	A20x12x125	74.5
C912/C913	3.625 _{h6}	7/8 × 7/8 × 5 ¹ / ₂	4.01	90 _{m6}	A25x14x140	95

Table No. 3 Motor Adapter Dimensions (mm)

Motor Adapter	Motor Shaft D ⁶ Max. ¹⁾	Thickness ²⁾ L ⁹ Min.	E	E ²	X	Wt. lbs.
MT10	19	21	140	70	40	5
MT20	24	24	160	80	50	8
MT30	38	25	200	100	60	12
MT40	48	33	250	125	89	18
MT50	60	43	300	150	81.5	16

Part No. Example

Round Flange with TriAdapt® Motor Adapter
C302F0620 MT10

¹⁾ If an adapter bushing is required it will be supplied as a component of the motor mounting plate.

²⁾ Motor plate maximum thickness (L⁹) will vary with motor shaft length but will not be less than shown.

For approximate weight, add adapter weight from Table 3 and base module weight from Table 4.



ServoFit® "C" Series – Concentric Helical Round Flange – "F" Housing Dimensional Data

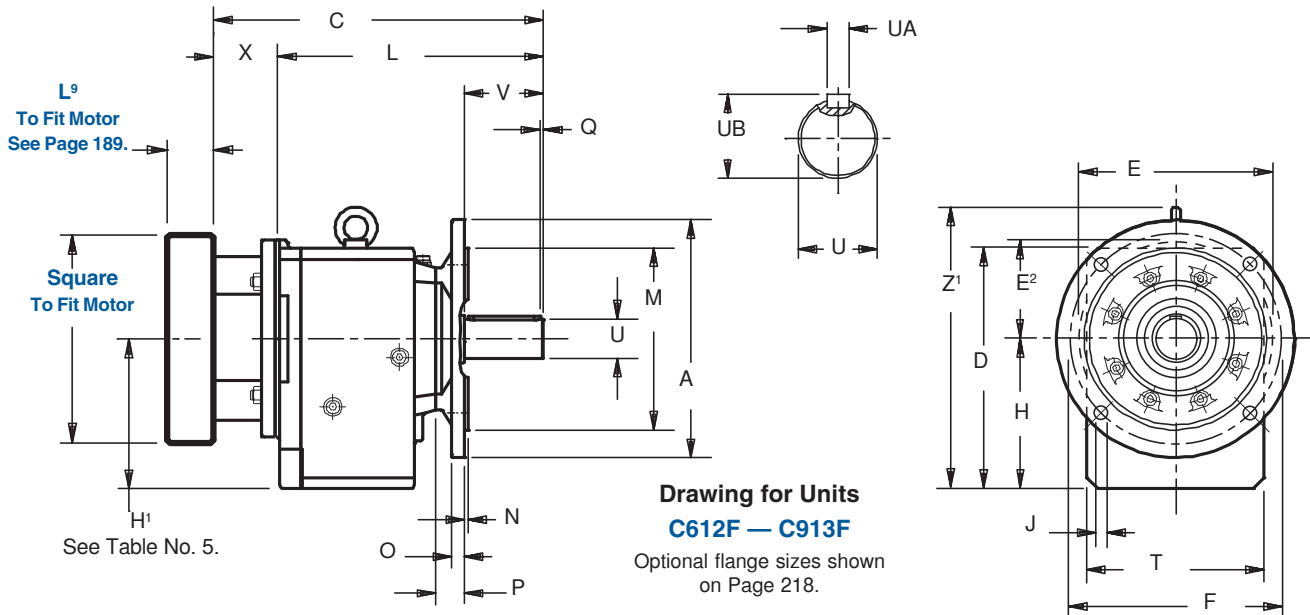
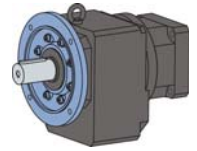

Table No. 4

"C" Series – Round Flange Unit Dimensions (mm) – "F" Housing Style

Base Module	MT10		MT20		MT30		MT40		MT50		Approx. Wt.(lbs.)
	C	L	C	L	C	L	C	L	C	L	
C002	194	154	208	158	—	—	—	—	—	—	18
C102	227	187	241	191	253	193	—	—	—	—	29
C103	264	224	—	—	—	—	—	—	—	—	34
C202	255	215	269	219	281	221	—	—	—	—	38
C203 ¹⁾	292	252	312	262	—	—	—	—	—	—	45
C302	—	—	288	238	300	240	332	243	—	—	49
C303 ¹⁾	311	271	331	281	—	—	—	—	—	—	56
C402	—	—	335.5	285.5	347.5	287.5	379.5	290.5	—	—	71
C403	—	—	378.5	328.5	—	—	—	—	—	—	78
C502	—	—	357	307	369	309	401	312	407.5	326	95
C503	—	—	400	350	—	—	—	—	—	—	111
C612 ¹⁾	—	—	—	—	393	333	425	336	430.5	349	115
C613 ¹⁾	—	—	425	375	455	395	—	—	—	—	159
C712	—	—	—	—	446	386	477	388	482.5	401	199
C713 ¹⁾	—	—	—	—	507	447	548	459	—	—	221
C812	—	—	—	—	—	—	544	455	549.5	468	322
C813	—	—	—	—	574	514	615	526	—	—	342
C912	—	—	—	—	—	—	—	—	616.5	535	596
C913	—	—	—	—	—	—	682	593	—	—	678

¹⁾ See Table No. 5

Table No. 5

"C" Series – Input Dimension

Base Module	MT20	MT30	MT40	MT50
C203	75.5	—	—	—
C303	90	—	—	—
C612	—	189	189	189
C613	—	—	189	—
C713	—	—	250	—

Units shown in Table 5 do not have a concentric input and output.

See Page 188 for Options and Part Number Configuration.

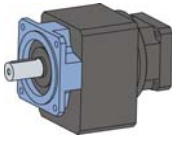

ServoFit® "C" Series – Concentric Helical Square Flange – "Q" Housing Dimensional Data

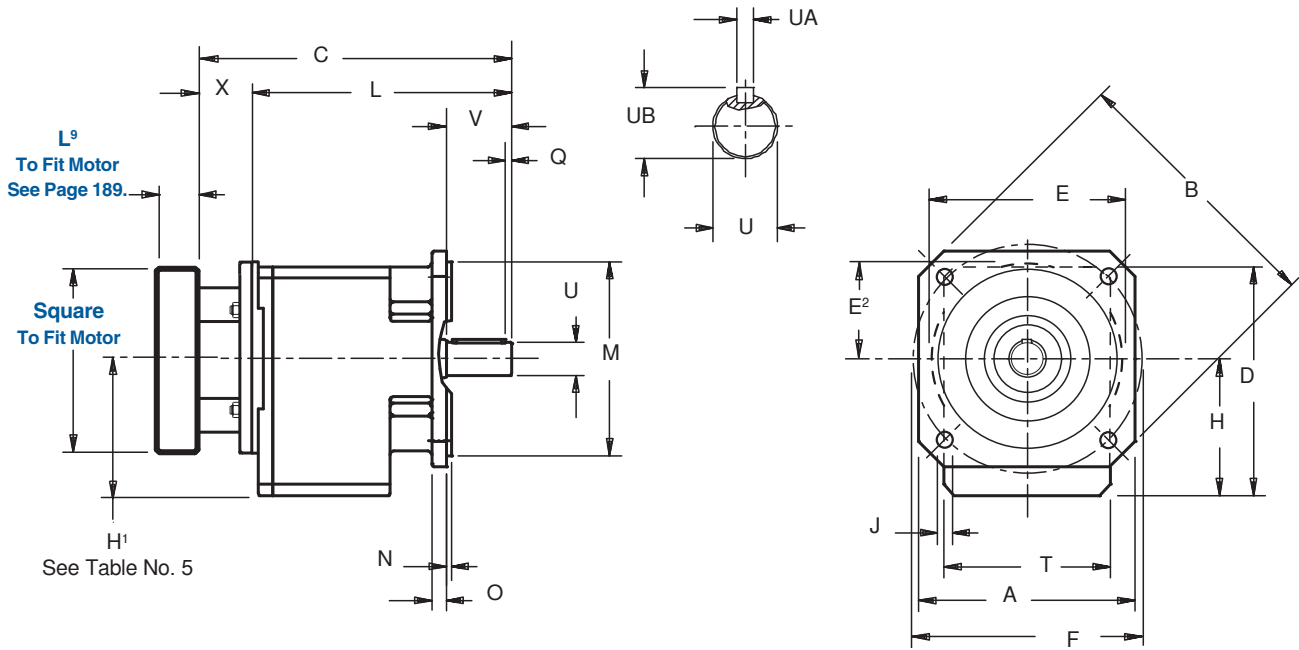

**Drawing for Units
C002Q – C503Q**

Table No. 1 "C" Series – Square Flange Unit Dimensions (mm) – "Q" Housing Style

Base Module	A	B	D	F	H	J	M	N	O	Q	T	V
C002	124	160	141	130	79	9	110 _{h6}	3	9	3	97	40
C102/C103	145	192	175	165	100	11	130 _{h6}	3.5	11	5	130	50
C202/C203	145	192	192	165	112 ¹⁾	11	130 _{h6}	3.5	11	5	142	60
C302/C303	200	250	212	215	127 ¹⁾	14	180 _{h6}	4	14	5	154	60
C402/C403	200	250	242.5	215	142.5	14	180 _{h6}	4	14	5	178	80

¹⁾See Table No. 5

Table No. 2 Metric output available on request

Base Module	Standard Shaft - inches			Optional Shaft - mm		
	U	UA	UB	U	UA	UB
C002	.750 _{h6}	$\frac{3}{16} \times \frac{3}{16} \times \frac{17}{32}$.83	20 _{h6}	A6x6x32	22.5
C102/C103	1.000 _{h6}	$\frac{1}{4} \times \frac{1}{4} \times \frac{9}{16}$	1.11	25 _{h6}	A8x7x40	28
C202/C203	1.250 _{h6}	$\frac{1}{4} \times \frac{1}{4} \times \frac{15}{16}$	1.36	30 _{h6}	A8x7X50	33
C302/C303	1.250 _{h6}	$\frac{1}{4} \times \frac{1}{4} \times \frac{15}{16}$	1.36	30 _{h6}	A8x7X50	33
C402/C403	1.625 _{h6}	$\frac{3}{8} \times \frac{3}{8} \times \frac{27}{8}$	1.79	40 _{h6}	A12x8X70	43

Contact STOBER Drives for availability of "Q" housing style.

For approximate weight, add adapter weight from Table 3 and base module weight from Table 4.



ServoFit® "C" Series – Concentric Helical Square Flange – "Q" Housing Dimensional Data

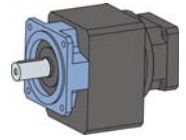

Table No. 3 Motor Adapter Dimensions (mm)

Motor Adapter	Motor Shaft D ⁶ Max. ¹⁾	Thickness ²⁾ L ⁹ Min.	E	E ²	X	Wt. lbs.
MT10	19	21	140	70	40	5
MT20	24	24	160	80	50	8
MT30	38	25	200	100	60	12
MT40	48	33	250	125	89	18

- 1) If an adapter bushing is required it will be supplied as a component of the motor mounting plate.
 2) Motor plate maximum thickness (L⁹) will vary with motor shaft length but will not be less than shown.

Table No. 4 "C" Series – Square Flange Unit Dimensions (mm) – "Q" Housing Style

Base Module	MT10		MT20		MT30		MT40		Approx. Wt.(lbs.)
	C	L	C	L	C	L	C	L	
C002	194	154	208	158	–	–	–	–	18
C102	227	187	241	191	253	193	–	–	29
C103	264	224	–	–	–	–	–	–	34
C202	255	215	269	269	281	221	–	–	38
C203 ¹⁾	292	252	312	262	–	–	–	–	45
C302	–	–	288	238	300	240	332	243	49
C303 ¹⁾	311	271	331	281	–	–	–	–	56
C402	–	–	335.5	285.5	347.5	287.5	379.5	290.5	71
C403	–	–	378.5	328.5	–	–	–	–	78

¹⁾ See Table No. 5

Table No. 5 Input Dimension (Inches)

Base	MT20
Module	H ¹
C203	75.5
C303	90

Units shown in Table 5 do not have a concentric input and output.

Part No. Example

Square Flange with TriAdapt® Motor Adapter
C302Q0620 MT20



See Page 188 for Options and Part Number Configuration.

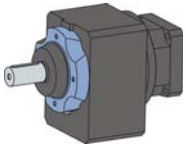

ServoFit® "C" Series – Concentric Helical Tapped Hole – "G" Housing Dimensional Data

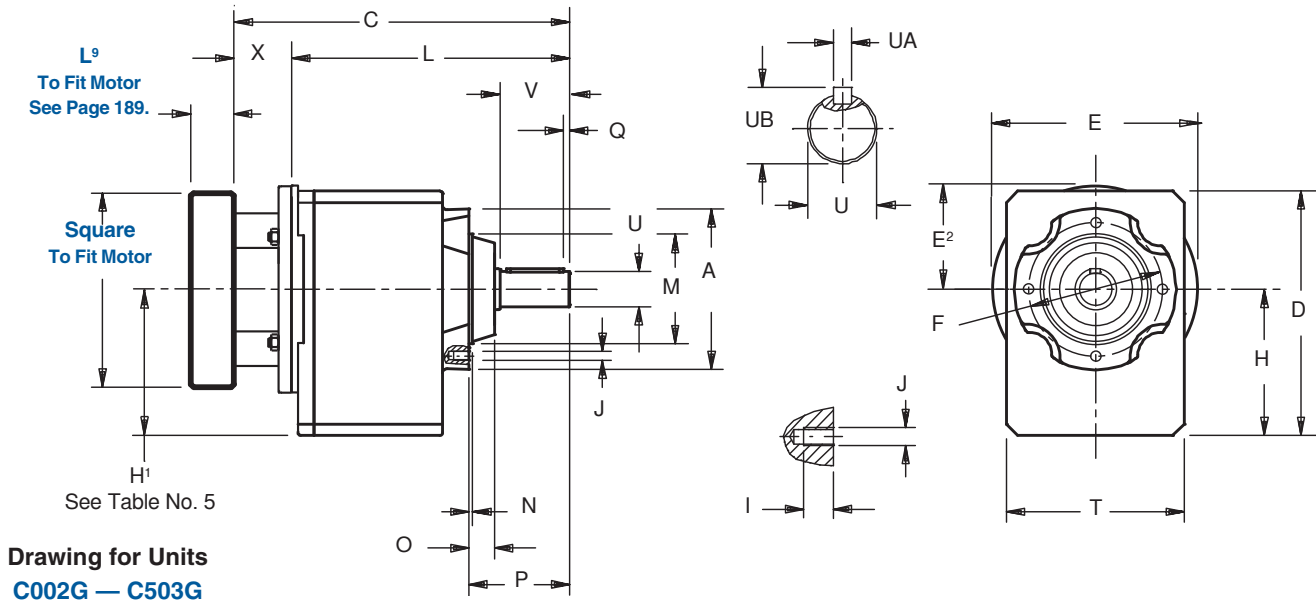

Drawing for Units
C002G — C503G

Table No. 1 "C" Series – Tapped Holes Unit Dimensions (mm) – "G" Housing Style

Base Module	A	D	F	H	I	J	M ₆	N	O	P	Q	T	V	Z
C002	87	141	75	79	10	4-M6	55	3	14	58	3	97	40	—
C102/C103	120	175	100	100	13	4-M6	80	3	17	71	5	130	50	—
C202/C203	140	192	115	112 ¹⁾	13	4-M8	95	3	22	87	5	142	60	—
C302/C303	140	212	115	127 ¹⁾	13	4-M8	95	3	22	87	5	154	60	—
C402/C403	160	242.5	130	142.5	16	4-M10	110	3.5	22	108	5	178	80	—
C502/C503	192	286	165	166	16	8-M10 ²⁾	130	3.5	23	109	5	195	80	—
C612/C613	180	310	165	195 ¹⁾	16	8-M10	140	5	30	136	5	225	100	362
C712/C713	195	371	185	231 ¹⁾	19	8-M12	155	8	37	164	5	265	120	432
C812/C813	226	445	215	285	19	8-M12	185	5	37	185	5	310	140	506
C912/C913	280	524	265	334	26	8-M16	230	5	42	220	5	365	170	594

¹⁾ See Table No. 5

²⁾ C502/C503 has 8 holes located as shown on drawing for C612G — C913G.

Table No. 2 Metric output available on request

Base Module	Standard Shaft - inches			Optional Shaft - mm		
	U	UA	UB	U	UA	UB
C002	.750 _{h6}	³ / ₁₆ × ³ / ₁₆ × 1 ⁷ / ₃₂	.83	20 _{k6}	A6x6x32	22.5
C102/C103	1.000 _{h6}	¹ / ₄ × ¹ / ₄ × 1 ⁹ / ₁₆	1.11	25 _{k6}	A8x7x40	28
C202/C203	1.250 _{h6}	¹ / ₄ × ¹ / ₄ × 1 ¹⁵ / ₁₆	1.36	30 _{k6}	A8x7X50	33
C302/C303	1.250 _{h6}	¹ / ₄ × ¹ / ₄ × 1 ¹⁵ / ₁₆	1.36	30 _{k6}	A8x7X50	33
C402/C403	1.625 _{h6}	³ / ₈ × ³ / ₈ × 2 ⁷ / ₈	1.79	40 _{k6}	A12x8X70	43
C502/C503	1.625 _{h6}	³ / ₈ × ³ / ₈ × 2 ⁷ / ₈	1.79	40 _{k6}	A12x8X70	43
C612/C613	2.125 _{h6}	¹ / ₂ × ¹ / ₂ × 3 ⁵ / ₃₂	2.35	50 _{k6}	A14x9x90	53.5
C712/C713	2.375 _{h6}	⁵ / ₈ × ⁵ / ₈ × 3 ¹⁵ / ₁₆	2.65	60 _{m6}	A18x11x100	64
C812/C813	2.875 _{h6}	³ / ₄ × ³ / ₄ × 4 ⁵ / ₁₆	3.21	70 _{m6}	A20x12x125	74.5
C912/C913	3.625 _{h6}	⁷ / ₈ × ⁷ / ₈ × 5 ¹ / ₂	4.01	90 _{m6}	A25x14x140	95

Table No. 3 Motor Adapter Dimensions (mm)

Motor Adapter	Motor Shaft D ⁶ Max. ¹⁾	Thickness ²⁾ L ⁹ Min.	E	E ²	X	Wt. lbs.
MT10	19	21	140	70	40	5
MT20	24	24	160	80	50	8
MT30	38	25	200	100	60	12
MT40	48	33	250	125	89	18
MT50	60	43	300	150	81.5	16

Part No. Example

Tapped Holes Housing with TriAdapt® Motor Adapter

C302G0620 MT20

¹⁾ If an adapter bushing is required it will be supplied as a component of the motor mounting plate.

²⁾ Motor plate maximum thickness (L⁹) will vary with motor shaft length but will not be less than shown.

For approximate weight, add adapter weight from Table 3 and base module weight from Table 4.



ServoFit® "C" Series – Concentric Helical Tapped Hole – "G" Housing

Dimensional Data

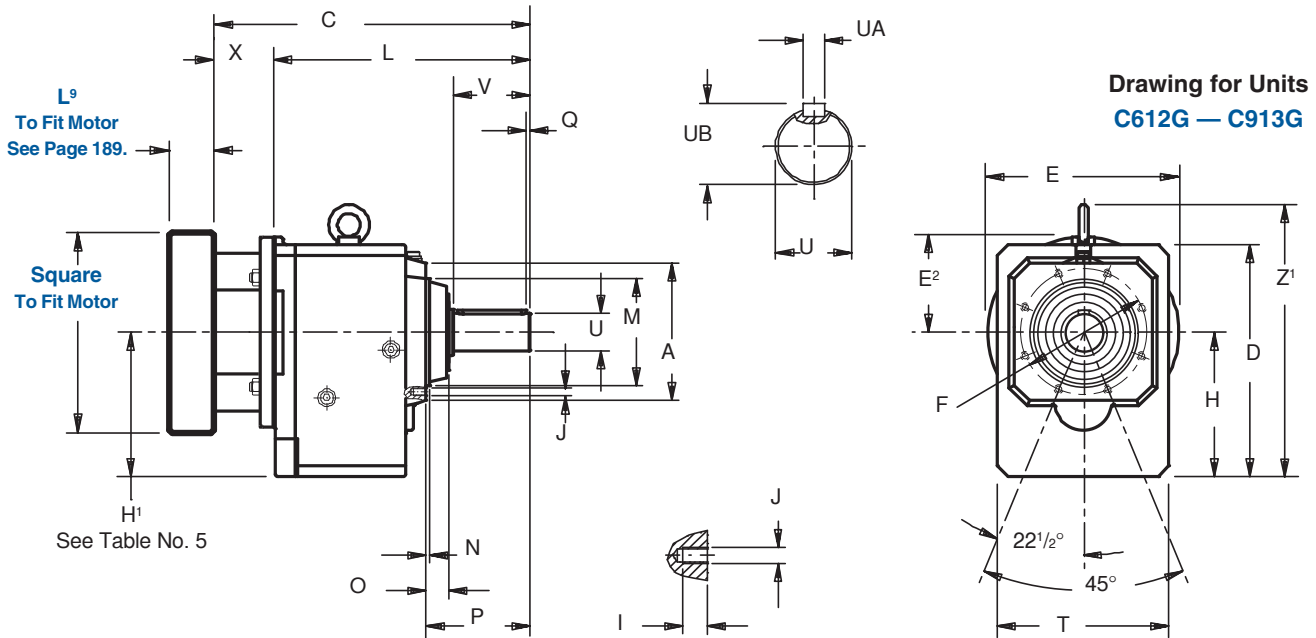
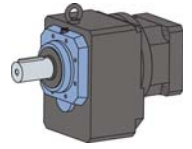

Table No. 4

"C" Series – Tapped Hole Unit Dimensions (mm) – "N" Housing Style

Base Module	MT10		MT20		MT30		MT40		MT50		Approx. Wt.(lbs.)
	C	L	C	L	C	L	C	L	C	L	
C002	194	154	208	158	—	—	—	—	—	—	18
C102	227	187	241	191	253	193	—	—	—	—	29
C103	264	224	—	—	—	—	—	—	—	—	34
C202	255	215	269	219	281	221	—	—	—	—	38
C203 ¹⁾	292	252	312	262	—	—	—	—	—	—	45
C302	—	—	288	238	300	240	332	243	—	—	49
C303 ¹⁾	311	271	331	281	—	—	—	—	—	—	56
C402	—	—	335.5	285.5	347.5	287.5	379.5	290.5	—	—	71
C403	—	—	378.5	328.5	—	—	—	—	—	—	78
C502	—	—	357	307	369	309	401	312	407.5	326	95
C503	—	—	400	350	—	—	—	—	—	—	111
C612 ¹⁾	—	—	—	—	393	333	425	336	430.5	349	115
C613 ¹⁾	—	—	425	375	455	395	—	—	—	—	159
C712	—	—	—	—	446	386	477	388	482.5	401	199
C713 ¹⁾	—	—	—	—	507	447	548	459	—	—	221
C812	—	—	—	—	—	—	544	455	549.5	468	322
C813	—	—	—	—	574	514	615	526	—	—	342
C912	—	—	—	—	—	—	—	—	616.5	535	596
C913	—	—	—	—	—	—	682	593	—	—	678

¹⁾ See Table No. 5

Table No. 5

"C" Series – Input Dimension

Base Module	MT20	MT30	MT40	MT50
C203	75.5	—	—	—
C303	90	—	—	—
C612	—	189	189	189
C613	—	—	189	—
C713	—	—	250	—

Units shown in Table 5 do not have a concentric input and output.

See Page 188 for Options and Part Number Configuration.

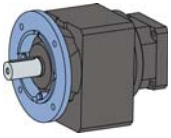

"C" Series – MGS Reducer Optional Output Flanges

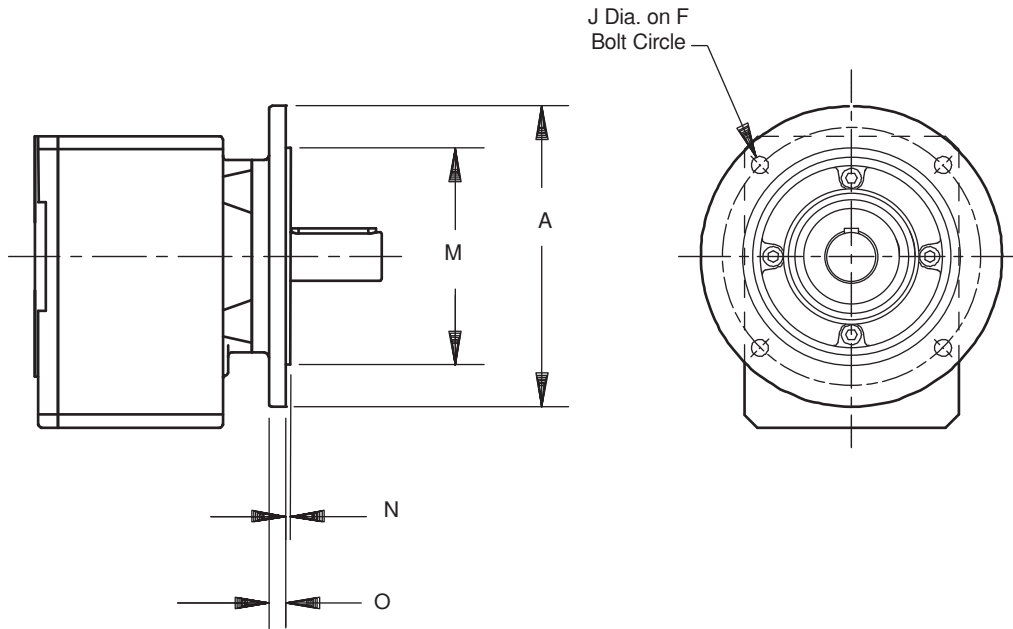

Table No. 1 Optional Flange Dimensions (mm)

Base Module	Flange Size	A	F	J	M	N	O
C0	120	120	100	7	80 _{js}	3	10
	140	140	115	9	95 _{js}	3	10
C1	140	140	115	9	95 _{js}	3.5	8
	160	160	130	9	110 _{js}	3.5	10
C2	160	160	130	9	110 _{js}	3.5	10
	250	250	215	14	180 _{js}	4	12
C3	160	160	130	9	110 _{js}	3.5	10
	200	200	165	11	130 _{js}	3.5	12
C4	200	200	165	11	130 _{js}	3.5	14
	300	300	265	14	230 _{js}	4	14
C5	250	250	215	14	180 _{js}	4	14
C8	350	350	300	18	250 _{h6}	5	18
	450	450	400	18	350 _{h6}	5	20

Optional flange are not available for all sizes.



"F" Series – Offset Helical ServoFit® Modular System Features

Compact size and flexibility make these gear drives a popular choice for applications that require high performance, efficiency, and durability. Series "F" gear drives, like all SMS units, are available with a wide selection of configurations to match almost any mounting requirement.

Performance Specifications:

- Input RPM up to 4,500 RPM
- Nominal output torque — 200 to 9,700 in. lbs. (22-1,100 Nm)
- Reducer ratios from 4.1:1 to 540:1
- 5 year limited warranty (2 years on bearings, seals, etc.)
- Ambient temperature — 0° C to +40° C (104° F) [Unit temperature ≤ 80° C Max.]
- Noise level — as low as 53 dB(A)
- ≥ 95.5% Efficiency
- Maintenance free
- Can be back driven



High quality helical gearing is case hardened to 58-62 Rockwell C. Precision finished for low noise and long service life. Standard backlash is ≤11 arc minutes
Reduced backlash is ≤7 arc minutes

Motor plate can easily be changed to fit your choice of motors.



Shipped with the proper amount of oil to prevent gear damaging dry start-ups

One-piece cast iron housing with precision machined bearing supports assure gearset alignment, prolongs bearing life, provides exceptional overhung load capacities, and eliminates leakage problems common to two-piece housings.

Double lip seals keep oil in and contaminants out. Double seals available for severe duty applications.

Output Options:

- Solid shaft
- Hollow
- Backlash free, wobble free bushings

Also available in metric or stainless shaft or quill.

Also available in washdown and poultry duty. Maximum 10 working days for custom motor plates.



"F" Series – Offset Helical ServoFit® Modular System

Mounting Positions – Must be Specified

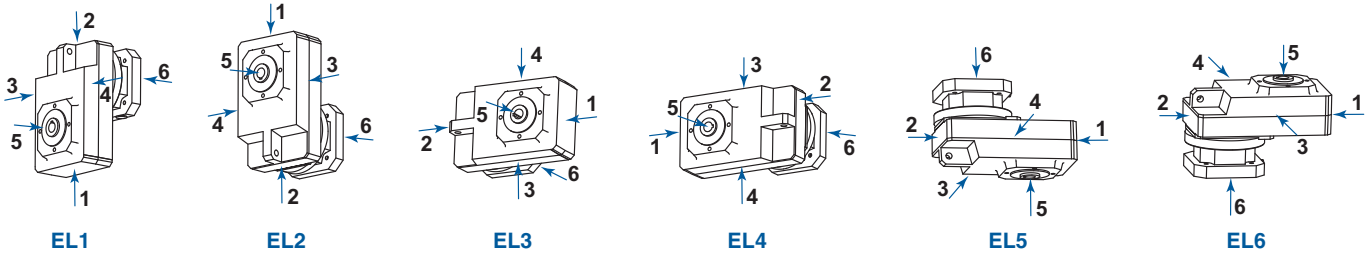

- EL1** Side 1 is the bottom side when the unit is set in a normal position. Side 1 is the down side for EL1.
- EL2** Side 2 is the top of the unit. Side 2 is the down side for EL2. (The unit is up-side-down.)
- EL3** Side 3 is the right side when facing the input with the unit in a normal position (EL1). Side 3 is the down side for EL3.
- EL4** Side 4 is the left side when facing the input with the unit in a normal position (EL1). Side 4 is the down side for EL4.
- EL5** Side 5 is the side opposite the motor. It is the side with the output shaft or mounting flange. Side 5 is the down side for EL5.
- EL6** Side 6 is the input or motor side. Side 6 is the down side for EL6.

DO NOT MOUNT any STOBER reducer in a position other than specified on the order.

All STOBER units are filled with the correct amount of lubrication before shipping. In order to provide the proper lubrication quantity **the mounting position must be specified at the time the unit is ordered.** Our web site: <http://www.stober.com/pages/lubrication-quantity> list the oil quantity for each size and mounting position.

Motor Mounting Specifications

STOBER ServoFit Gearheads will fit the motor of your choice by assembling the correct motor mounting plate between the motor and the gearhead. **When ordering a gearhead, specify the motor manufacturer and part number, provide the motor drawing with dimensions, or specify the motor mounting dimensions.** The motor plate thickness (L^9) dimension will be determined by the motor shaft length. The minimum motor plate thickness is shown below. For a precise dimension on a specific motor, contact STOBER Technical Support.

The following dimensions are required to provide the correct motor mounting plate:

1. D^6 Motor Shaft Diameter (If an adapter bushing is required it will be supplied with the motor plate.)
2. D^7 Pilot Diameter
3. D^8 Bolt Circle Diameter
4. D^9 Bolt Diameter
5. L^{11} Motor Shaft Length
6. L^{12} Pilot Length
7. L^{14} Square Flange (Optional — Motor plate will typically be made to match.)

Table No.1

Input Option	Shaft D^6 Max.	Motor Plate Thickness L^9 Min.
MT10	19	21
MT20	24	24
MT30	38	25
MT40	48	33
MT50	60	43

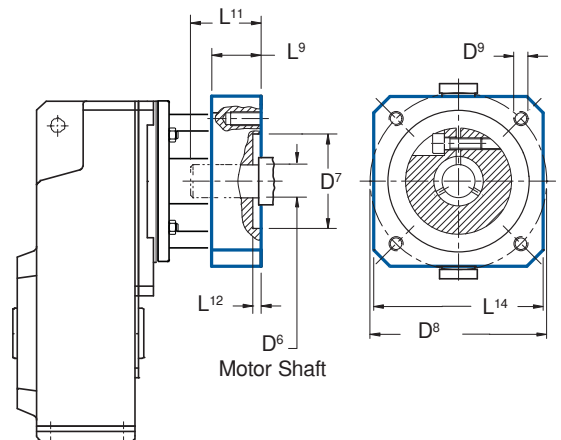

Refer to Page 302 for ServoFit Gearhead Selection Procedure.

“F” Series – Offset Helical ServoFit® Modular System



Maintenance

With STOBER reducers very little maintenance is required under normal operating conditions. Units supplied without breathers are lubricated for life and maintenance free. “F” Series gearheads do not have a breather.

Direction of Rotation

2 Stage — F102 thru F602

3 Stage — F203 thru F603

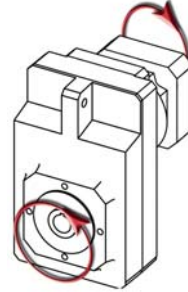
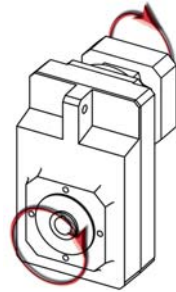

F

Overhung Load

Pulling forces or overhung load of pulleys, sheaves, sprockets, etc. on the reducer output shaft must not exceed the allowable limits shown in the above calculations. The overhung load shown is measured at the center of the shaft extension.

The following formula can be used to determine actual overhung load for a given drive.

METRIC

$$OHL = \frac{19,100 \times kW \times K}{D \times n}$$

where

- OHL = Newtons (N)
- kW = Transmitted Kilowatt
- D = Pitch Diameter (meters) of Sprocket, Gear, Sheave, Pulley, etc.
- n = Maximum Shaft RPM
- K = 1.00 Single Chain Drive
- 1.25 Timing Belt Drive
- 1.25 Spur, Helical Gear Drive
- 1.50 V-Belt Drive
- 2.50 Flat Belt Drive

IMPERIAL

$$OHL = \frac{126,000 \times HP \times K}{D \times RPM}$$

where

- OHL = Pounds (lbs.)
- HP = Horsepower
- D = Pitch Diameter (inches) of Sprocket, Gear, Sheave, Pulley, etc.
- n = Maximum Shaft RPM
- K = 1.00 Single Chain Drive
- 1.25 Timing Belt Drive
- 1.25 Spur, Helical Gear Drive
- 1.50 V-Belt Drive
- 2.50 Flat Belt Drive

No overhung load is encountered when an reducer is flange mounted and/or coupling connected to another unit. However, the shafts of all components must be accurately aligned and secured to prevent pre-loading of the bearings and premature bearing failure.



“F” Series – Offset Helical ServoFit® Modular System Shaft Loads

Permissible Shaft Load and Tilting Moment

The permissible load values given are valid with the load applied to the center of the output shaft (x_2).

The permissible load and tilting moment values are based on an output speed of 20 RPM. For higher speeds the following applies, where n_2 is the desired speed:

$$F_{2AX} = \frac{F_{2A}}{\sqrt[3]{\frac{n_2}{20}}} \quad F_{2RX} = \frac{F_{2R}}{\sqrt[3]{\frac{n_2}{20}}} \quad M_{2KX} = \frac{M_{2K}}{\sqrt[3]{\frac{n_2}{20}}}$$

The application input tilting moment should be determined by the following formula:

$$M_{2A} = \frac{2 \cdot F_{2a} \cdot y_2 + F_{2r} \cdot (x_2 + z_2)}{1000} \leq M_{2K}$$

- F_{2a} Axial Load at Output Shaft
- F_{2A} Permissible Axial Load
- F_{2r} Radial Load at Output Shaft
- F_{2R} Permissible Radial Load
- F_{2RB} ... Acceleration Permissible Radial Load
- M_{2K} ... Rated Tilting Torque
- M_{2k} Equivalent Tilting Load
- z₂ Distance Factor

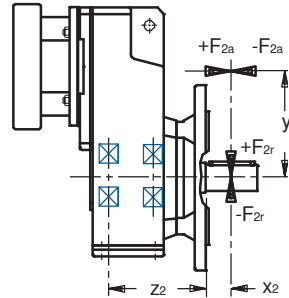

Table No. 2 “F” Series – Permissible Load and Tilting Moments

Unit No.	Solid Shaft Output – “V” Style						Hollow Output – “A”, “W”, and “S” Style ¹⁾								
	z ₂		F _{2A}		F _{2R}		M _{2K}		Unit No.	z ₂		F _{2A}		M _{2K}	
	mm	inches	N	lbs.	N	lbs.	Nm	in.lbs.		mm	inches	N	lbs.	Nm	in.lbs.
F1_V	35	1.38	1,100	247	4,200	945	260	2,301	F1_A	30	1.18	900	203	175	1,549
F2_V	41	1.61	1,400	351	5,400	1,215	400	3,540	F2_A	33	1.30	1,200	270	250	2,213
F3_V	43	1.69	1,900	427	7,500	1,687	600	5,310	F3_A	33	1.30	1,350	304	375	3,319
F4_V	44	1.73	2,350	528	9,250	2,081	800	7,080	F4_A	39	1.54	1,900	428	550	4,858
F6_V	44	1.73	3,100	697	12,500	2,812	1,200	10,620	F6_A	45	1.77	2,200	495	800	7,080

¹⁾ Values shown for “W” Style are for double bushings. For single bushings use value M_{2K} x 0.5 and F_{2A} x 0.5.

Permissible Motor Tilting Torque

The permissible tilting torque of the motor attached to the gear unit is a result of the static and dynamic load “F” from the motor weight, mass acceleration, and vibration multiplied by the distance from the center of gravity “I_s” of the motor.

$$M_{1K} = F \times I_s \leq M_{1K}$$

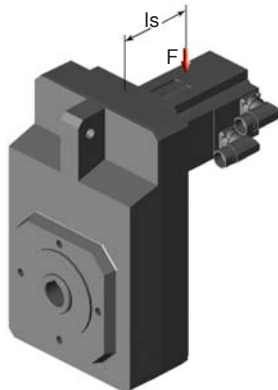

Table No. 1 M_{1K} Permissible Motor Tilting Torque

“F” Series Unit with MT	Nm	in. lbs.
MT10	25	221
MT20	60	531
MT30	125	1,106
MT40	250	2,212
MT50	600	5,310



"F" Series – Offset Helical ServoFit® Modular System Selection Data



Part Number	Reducer Ratio i		Input RPM			Backlash arcmins $\Delta\phi$ ¹⁾	Input Inertia J ₁ kgcm ²	Torsional Stiffness per arcmin C ₂		Output Torque					
			Maximum							Nominal ²⁾		Acceleration		Peak ³⁾	
	Nom.	Exact	n _{1DBH}	n _{1DBV}	n _{1ZB}			M _{2N} ≤ 2000 RPM		M _{2B}		M _{2PEAK}			
								Continuous	Cyclic	in.lbs.	Nm	in.lbs.	Nm	in.lbs.	Nm
F102 with MT TriAdapt® Motor Adapter															
Noise Level ≤ 55 dB(A) ⁴⁾															
F102_0043 MT10	4.308	56/13	3,500	3,000	6,000	11/8	2.1	35	4.0	396	45	396	45	496	56
F102_0043 MT20	4.308	56/13	3,500	3,000	5,000	11/8	2.7	37	4.1	539	61	746	84	933	105
F102_0065 MT10	6.462	84/13	3,500	3,000	6,000	11/8	1.4	45	5.1	563	64	563	64	704	79
F102_0065 MT20	6.462	84/13	3,500	3,000	5,000	11/8	2.0	46	5.2	617	70	930	105	1,326	150
F102_0072 MT10	7.156	322/45	3,700	3,600	6,000	11/8	1.2	47	5.3	613	69	613	69	767	87
F102_0072 MT20	7.156	322/45	3,500	3,500	5,000	11/8	1.8	48	5.4	639	72	930	105	1,444	163
F102_0089 MT10	8.948	1029/115	3,700	3,600	6,000	11/8	1.0	50	5.7	688	78	737	83	921	104
F102_0089 MT20	8.948	1029/115	3,500	3,500	5,000	11/8	1.6	51	5.8	688	78	930	105	1,734	196
F102_0110 MT10	10.92	273/25	4,000	4,000	6,000	11/8	0.9	53	5.9	735	83	868	98	1,085	123
F102_0110 MT20	10.92	273/25	3,500	3,500	5,000	11/8	1.5	53	6.0	735	83	930	105	1,772	200
F102_0135 MT10	13.59	231/17	4,000	4,000	6,000	11/8	0.8	54	6.1	791	89	930	105	1,297	146
F102_0135 MT20	13.59	231/17	3,500	3,500	5,000	11/8	1.4	55	6.2	791	89	930	105	1,772	200
F102_0185 MT10	18.46	1495/81	3,700	3,600	6,000	11/6	0.9	66	7.4	876	99	1,063	120	1,978	223
F102_0185 MT20	18.46	1495/81	3,500	3,500	5,000	11/6	1.5	66	7.5	876	99	1,063	120	2,126	240
F102_0230 MT10	23.08	3185/138	3,700	3,600	6,000	11/6	0.8	67	7.5	944	107	1,063	120	2,126	240
F102_0230 MT20	23.08	3185/138	3,500	3,500	5,000	11/6	1.4	67	7.6	944	107	1,063	120	2,126	240
F102_0280 MT10	28.17	169/6	4,000	4,000	6,000	11/6	0.8	67	7.6	1,009	114	1,063	120	2,126	240
F102_0280 MT20	28.17	169/6	3,500	3,500	5,000	11/6	1.4	67	7.6	1,009	114	1,063	120	2,126	240
F102_0350 MT10	35.05	3575/102	4,000	4,000	6,000	11/6	0.7	68	7.7	1,063	120	1,063	120	2,126	240
F102_0350 MT20	35.05	3575/102	3,500	3,500	5,000	11/6	1.3	68	7.7	1,063	120	1,063	120	2,126	240
F102_0460 MT10	46.43	325/7	4,000	4,000	6,000	11/6	0.7	68	7.7	1,063	120	1,063	120	2,126	240
F102_0460 MT20	46.43	325/7	3,500	3,500	5,000	11/6	1.3	68	7.7	1,063	120	1,063	120	2,126	240
F102_0560 MT10	55.97	2015/36	4,000	4,000	6,000	11/6	0.7	68	7.7	1,063	120	1,063	120	2,126	240
F102_0560 MT20	55.97	2015/36	3,500	3,500	5,000	11/6	1.3	68	7.7	1,063	120	1,063	120	2,126	240
F102_0700 MT10	70.06	1261/18	4,000	4,000	6,000	11/6	0.6	68	7.7	1,063	120	1,063	120	2,126	240
F102_0700 MT20	70.06	1261/18	3,500	3,500	5,000	11/6	1.2	68	7.7	1,063	120	1,063	120	2,126	240
F102_0940 MT10	93.63	7865/84	4,000	4,000	6,000	11/6	0.6	68	7.7	1,063	120	1,063	120	2,126	240
F102_1120 MT10	111.9	2015/18	4,000	4,000	6,000	11/6	0.6	68	7.7	1,063	120	1,063	120	2,126	240
F102_1400 MT10	139.8	559/4	4,000	4,000	6,000	11/6	0.6	69	7.7	1,063	120	1,063	120	2,126	240
F202 with MT TriAdapt® Motor Adapter															
Noise Level ≤ 53 dB(A) ⁴⁾															
F202_0047 MT10	4.680	2616/559	3,100	2,600	5,000	11/8	4.7	60	6.8	452	51	452	51	564	64
F202_0047 MT20	4.680	2616/559	3,100	2,600	5,000	11/8	5.3	64	7.2	1,103	125	1,769	200	2,495	282
F202_0047 MT30	4.680	2616/559	3,100	2,600	4,000	11/8	10.1	80	9.1	1,103	125	1,860	210	2,495	282
F202_0056 MT20	5.552	5341/962	3,100	2,600	5,000	11/8	4.2	75	8.5	1,168	132	1,860	210	2,921	330
F202_0056 MT30	5.552	5341/962	3,100	2,600	4,000	11/8	9.0	91	10.3	1,168	132	1,860	210	2,921	330
F202_0072 MT10	7.167	5777/806	3,600	3,100	6,000	11/8	2.5	89	10.0	653	74	653	74	816	92
F202_0072 MT20	7.167	5777/806	3,500	3,100	5,000	11/8	3.1	92	10.4	1,272	144	1,860	210	3,543	400
F202_0072 MT30	7.167	5777/806	3,500	3,100	4,000	11/8	7.9	106	11.9	1,272	144	1,860	210	3,543	400
F202_0090 MT10	9.006	3161/351	3,600	3,100	6,000	11/8	1.9	102	11.5	793	89	793	89	991	112
F202_0090 MT20	9.006	3161/351	3,500	3,100	5,000	11/8	2.5	105	11.8	1,372	155	1,860	210	3,543	400
F202_0090 MT30	9.006	3161/351	3,500	3,100	4,000	11/8	7.3	115	13.0	1,372	155	1,860	210	3,543	400
F202_0110 MT10	10.80	7303/676	3,800	3,500	6,000	11/8	1.5	111	12.5	917	104	917	104	1,147	129
F202_0110 MT20	10.80	7303/676	3,500	3,500	5,000	11/8	2.1	113	12.8	1,458	165	1,860	210	3,543	400
F202_0110 MT30	10.80	7303/676	3,500	3,500	4,000	11/8	6.9	121	13.7	1,458	165	1,860	210	3,543	400
F202_0135 MT10	13.63	109/8	3,800	3,500	6,000	11/8	1.2	120	13.5	1,112	126	1,112	126	1,391	157
F202_0135 MT20	13.63	109/8	3,500	3,500	5,000	11/8	1.8	121	13.7	1,576	178	1,860	210	3,543	400
F202_0135 MT30	13.63	109/8	3,500	3,500	4,000	11/8	6.6	127	14.3	1,576	178	1,860	210	3,543	400

1) Backlash shown "STANDARD/REDUCED".
 2) Maximum torque for continuous input RPM - horizontal output position.
 3) Maximum momentary torque for emergency stops or heavy shock load. Admissible stops per life of reducer = 1,000 stops maximum.
 4) dB(A) Measured at 1 meter distance with 3000 RPM input.

Maximum Motor Shaft			
Adapter	Diameter	Adapter	Diameter
MT10	19	MT30	38
MT20	24	MT40	48



"F" Series – Offset Helical ServoFit® Modular System Selection Data



Part Number	Reducer Ratio i		Input RPM			Backlash arcmins $\Delta\phi$ ¹⁾	Input Inertia J ₁ kgcm ²	Torsional Stiffness per arcmin C ₂		Output Torque					
			Maximum							Nominal ²⁾		Acceleration		Peak ³⁾	
	Nom.	Exact	n _{1DBH}	n _{1DBV}	n _{1ZB}			M _{2N} ≤ 2000 RPM		M _{2B}		M _{2PEAK}			
								Continuous	Cyclic	in.lbs.	Nm	in.lbs.	Nm	in.lbs.	Nm
F202 with MT TriAdapt® Motor Adapter <i>Continued</i>										Noise Level ≤ 53 dB(A) ⁴⁾					
F202_0185 MT10	18.65	6360/341	3,600	3,100	6,000	11/6	1.5	145	16.4	1,699	192	1,699	192	2,124	240
F202_0185 MT20	18.65	6360/341	3,500	3,100	5,000	11/6	2.1	146	16.5	1,749	197	2,392	270	4,252	480
F202_0185 MT30	18.65	6360/341	3,500	3,100	4,000	11/6	6.9	151	17.0	1,749	197	2,392	270	4,252	480
F202_0230 MT10	23.43	2320/99	3,600	3,100	6,000	11/6	1.3	150	16.9	1,888	213	2,062	233	2,578	291
F202_0230 MT20	23.43	2320/99	3,500	3,100	5,000	11/6	1.9	151	17.0	1,888	213	2,392	270	4,252	480
F202_0230 MT30	23.43	2320/99	3,500	3,100	4,000	11/6	6.7	154	17.3	1,888	213	2,392	270	4,252	480
F202_0280 MT10	28.11	4020/143	3,800	3,500	6,000	11/6	1.1	152	17.2	2,006	226	2,387	269	2,984	337
F202_0280 MT20	28.11	4020/143	3,500	3,500	5,000	11/6	1.7	153	17.3	2,006	226	2,392	270	4,252	480
F202_0280 MT30	28.11	4020/143	3,500	3,500	4,000	11/6	6.5	155	17.5	2,006	226	2,392	270	4,252	480
F202_0350 MT10	35.46	390/11	3,800	3,500	6,000	11/6	1.0	155	17.5	2,126	240	2,392	270	3,618	408
F202_0350 MT20	35.46	390/11	3,500	3,500	5,000	11/6	1.6	155	17.5	2,126	240	2,392	270	4,252	480
F202_0350 MT30	35.46	390/11	3,500	3,500	4,000	11/6	6.4	156	17.7	2,126	240	2,392	270	4,252	480
F202_0470 MT10	47.05	1035/22	4,000	3,900	6,000	11/6	0.8	156	17.7	2,126	240	2,392	270	4,252	480
F202_0470 MT20	47.05	1035/22	3,500	3,500	5,000	11/6	1.4	157	17.7	2,126	240	2,392	270	4,252	480
F202_0470 MT30	47.05	1035/22	3,500	3,500	4,000	11/6	6.2	157	17.8	2,126	240	2,392	270	4,252	480
F202_0570 MT10	56.73	624/11	4,000	3,900	6,000	11/6	0.8	157	17.7	2,126	240	2,392	270	4,252	480
F202_0570 MT20	56.73	624/11	3,500	3,500	5,000	11/6	1.4	157	17.8	2,126	240	2,392	270	4,252	480
F202_0570 MT30	56.73	624/11	3,500	3,500	4,000	11/6	6.2	158	17.8	2,126	240	2,392	270	4,252	480
F202_0700 MT10	70.13	5400/77	4,000	3,900	6,000	11/6	0.7	158	17.8	2,126	240	2,392	270	4,252	480
F202_0700 MT20	70.13	5400/77	3,500	3,500	5,000	11/6	1.3	158	17.8	2,126	240	2,392	270	4,252	480
F202_0700 MT30	70.13	5400/77	3,500	3,500	4,000	11/6	6.1	158	17.9	2,126	240	2,392	270	4,252	480
F202_0940 MT10	93.82	1032/11	4,000	3,900	6,000	11/6	0.7	158	17.9	2,126	240	2,392	270	4,252	480
F202_0940 MT20	93.82	1032/11	3,500	3,500	5,000	11/6	1.3	158	17.9	2,126	240	2,392	270	4,252	480
F202_1130 MT10	112.7	1240/11	4,000	3,900	6,000	11/6	0.7	158	17.9	2,126	240	2,392	270	4,252	480
F202_1410 MT10	140.9	1550/11	4,000	3,900	6,000	11/6	0.6	158	17.9	2,126	240	2,392	270	4,252	480
F203 with MT TriAdapt® Motor Adapter										Noise Level ≤ 53 dB(A) ⁴⁾					
F203_1840 MT10	184.3	16215/88	4,000	3,900	6,000	11/7	0.7	159	17.9	2,126	240	2,392	270	4,252	480
F203_2220 MT10	222.2	2444/11	4,000	3,900	6,000	11/7	0.7	159	17.9	2,126	240	2,392	270	4,252	480
F203_2750 MT10	274.7	21150/77	4,000	3,900	6,000	11/7	0.7	159	17.9	2,126	240	2,392	270	4,252	480
F203_3670 MT10	367.5	4042/11	4,000	3,900	6,000	11/7	0.7	159	17.9	2,126	240	2,392	270	4,252	480
F203_4420 MT10	441.5	14570/33	4,000	3,900	6,000	11/7	0.6	159	17.9	2,126	240	2,392	270	4,252	480
F203_5520 MT10	551.9	36425/66	4,000	3,900	6,000	11/7	0.6	159	17.9	2,126	240	2,392	270	4,252	480



See Page 220 for Options and Part Number Configuration.



"F" Series – Offset Helical ServoFit® Modular System Selection Data



Part Number	Reducer Ratio i		Input RPM			Backlash arcmins $\Delta\phi$ ¹⁾	Input Inertia J ₁ kgcm ²	Torsional Stiffness per arcmin C ₂		Output Torque						
			Maximum							Nominal ²⁾		Acceleration		Peak ³⁾		
	Nom.		Exact		n _{1DBH}			n _{1DBV}	n _{1ZB}	M _{2N} ≤ 2000 RPM		M _{2B}		M _{2PEAK}		
										in.lbs.	Nm	in.lbs.	Nm	in.lbs.	Nm	in.lbs.
F302 with MT TriAdapt® Motor Adapter															Noise Level ≤ 53 dB(A) ⁴⁾	
F302_0046 MT20	4.644	4992/1075	3,000	2,600	4,500	11/8	9.4	71	8.0	1,596	180	1,756	198	2,576	291	
F302_0046 MT30	4.644	4992/1075	3,000	2,600	4,000	11/8	14.2	92	10.4	1,832	207	3,094	349	5,758	650	
F302_0057 MT20	5.720	143/25	3,000	2,600	4,500	11/8	6.9	89	10.1	1,963	222	2,163	244	3,069	346	
F302_0057 MT30	5.720	143/25	3,000	2,600	4,000	11/8	11.7	111	12.5	1,963	222	2,455	277	3,069	346	
F302_0072 MT20	7.172	208/29	3,500	3,100	5,000	11/8	5.1	109	12.3	2,117	239	2,711	306	3,741	422	
F302_0072 MT30	7.172	208/29	3,500	3,100	4,000	11/8	9.9	129	14.5	2,117	239	2,992	338	3,741	422	
F302_0090 MT20	8.986	5616/625	3,500	3,100	5,000	11/8	3.8	128	14.4	2,282	258	3,100	350	4,516	510	
F302_0090 MT30	8.986	5616/625	3,500	3,100	4,000	11/8	8.6	144	16.2	2,282	258	3,100	350	4,516	510	
F302_0110 MT20	10.79	1456/135	3,500	3,500	5,000	11/8	3.1	140	15.8	2,426	274	3,100	350	5,225	590	
F302_0110 MT30	10.79	1456/135	3,500	3,500	4,000	11/8	7.9	153	17.3	2,426	274	3,100	350	5,225	590	
F302_0135 MT10	13.38	7696/575	3,700	3,500	5,500	11/8	1.9	149	16.9	1,127	127	1,127	127	1,409	159	
F302_0135 MT20	13.38	7696/575	3,500	3,500	5,000	11/8	2.5	152	17.2	2,607	294	3,100	350	5,758	650	
F302_0135 MT30	13.38	7696/575	3,500	3,500	4,000	11/8	7.3	162	18.3	2,607	294	3,100	350	5,758	650	
F302_0190 MT20	18.77	4900/261	3,500	3,100	5,000	11/6	3.1	175	19.8	2,918	329	3,986	450	7,086	800	
F302_0190 MT30	18.77	4900/261	3,500	3,100	4,000	11/6	7.9	182	20.5	2,918	329	3,986	450	7,086	800	
F302_0240 MT20	23.52	588/25	3,500	3,100	5,000	11/6	2.6	182	20.5	3,146	355	3,986	450	7,086	800	
F302_0240 MT30	23.52	588/25	3,500	3,100	4,000	11/6	7.4	186	21.0	3,146	355	3,986	450	7,086	800	
F302_0280 MT20	28.23	6860/243	3,500	3,500	5,000	11/6	2.2	185	20.9	3,343	377	3,986	450	7,086	800	
F302_0280 MT30	28.23	6860/243	3,500	3,500	4,000	11/6	7.0	188	21.2	3,343	377	3,986	450	7,086	800	
F302_0350 MT10	35.03	7252/207	3,700	3,500	5,500	11/6	1.3	187	21.1	2,951	333	2,951	333	3,689	416	
F302_0350 MT20	35.03	7252/207	3,500	3,500	5,000	11/6	1.9	188	21.2	3,543	400	3,986	450	7,086	800	
F302_0350 MT30	35.03	7252/207	3,500	3,500	4,000	11/6	6.7	190	21.4	3,543	400	3,986	450	7,086	800	
F302_0470 MT10	47.19	1274/27	4,000	3,900	6,000	11/6	1.1	190	21.4	3,543	400	3,738	422	4,673	528	
F302_0470 MT20	47.19	1274/27	3,500	3,500	5,000	11/6	1.7	190	21.5	3,543	400	3,986	450	7,086	800	
F302_0470 MT30	47.19	1274/27	3,500	3,500	4,000	11/6	6.5	191	21.6	3,543	400	3,986	450	7,086	800	
F302_0560 MT10	56.49	4067/72	4,000	3,900	6,000	11/6	1.0	191	21.6	3,543	400	3,986	450	5,414	611	
F302_0560 MT20	56.49	4067/72	3,500	3,500	5,000	11/6	1.6	191	21.6	3,543	400	3,986	450	7,086	800	
F302_0560 MT30	56.49	4067/72	3,500	3,500	4,000	11/6	6.4	192	21.7	3,543	400	3,986	450	7,086	800	
F302_0700 MT10	70.36	2744/39	4,000	3,900	6,000	11/6	0.9	192	21.6	3,543	400	3,986	450	6,402	723	
F302_0700 MT20	70.36	2744/39	3,500	3,500	5,000	11/6	1.5	192	21.7	3,543	400	3,986	450	7,086	800	
F302_0700 MT30	70.36	2744/39	3,500	3,500	4,000	11/6	6.3	192	21.7	3,543	400	3,986	450	7,086	800	
F302_0940 MT10	93.64	4214/45	4,000	3,900	6,000	11/6	0.8	192	21.7	3,543	400	3,986	450	7,086	800	
F302_0940 MT20	93.64	4214/45	3,500	3,500	5,000	11/6	1.4	192	21.7	3,543	400	3,986	450	7,086	800	
F302_0940 MT30	93.64	4214/45	3,500	3,500	4,000	11/6	6.2	193	21.8	3,543	400	3,986	450	7,086	800	
F302_1130 MT10	112.8	3724/33	4,000	3,900	6,000	11/6	0.7	193	21.8	3,543	400	3,986	450	7,086	800	
F302_1130 MT20	112.8	3724/33	3,500	3,500	5,000	11/6	1.3	193	21.8	3,543	400	3,986	450	7,086	800	
F302_1410 MT10	140.6	7595/54	4,000	3,900	6,000	11/6	0.7	193	21.8	3,543	400	3,986	450	5,771	652	
F303 with MT TriAdapt® Motor Adapter															Noise Level ≤ 53 dB(A) ⁴⁾	
F303_1820 MT20	182.4	73892/405	3,500	3,500	5,000	11/7	1.4	193	21.8	3,543	400	3,986	450	7,086	800	
F303_1850 MT10	184.8	29939/162	4,000	3,900	6,000	11/7	0.7	193	21.8	3,543	400	3,986	450	7,086	800	
F303_2180 MT20	218.4	117943/540	3,500	3,500	5,000	11/7	1.4	193	21.8	3,543	400	3,986	450	7,086	800	
F303_2210 MT10	221.2	191149/864	4,000	3,900	6,000	11/7	0.7	193	21.8	3,543	400	3,986	450	7,086	800	
F303_2720 MT20	272.1	159152/585	3,500	3,500	5,000	11/7	1.4	193	21.8	3,543	400	3,986	450	7,086	800	
F303_2760 MT10	275.6	32242/117	4,000	3,900	6,000	11/7	0.7	193	21.8	3,543	400	3,986	450	7,086	800	
F303_3620 MT20	362.1	244412/675	3,500	3,500	5,000	11/7	1.4	193	21.8	3,543	400	3,986	450	7,086	800	
F303_3670 MT10	366.8	99029/270	4,000	3,900	6,000	11/7	0.7	193	21.8	3,543	400	3,986	450	7,086	800	
F303_4420 MT10	442.0	43757/99	4,000	3,900	6,000	11/7	0.7	193	21.8	3,543	400	3,986	450	7,086	800	
F303_5510 MT10	550.9	356965/648	4,000	3,900	6,000	11/7	0.7	193	21.8	3,543	400	3,986	450	5,771	651	

1) Backlash shown "STANDARD/REDUCED".
 2) Maximum torque for continuous input RPM - horizontal output position.
 3) Maximum momentary torque for emergency stops or heavy shock load. Admissible stops per life of reducer = 1,000 stops maximum.
 4) dB(A) Measured at 1 meter distance with 3000 RPM input.

Maximum Motor Shaft			
Adapter	Diameter	Adapter	Diameter
MT10	19	MT30	38
MT20	24	MT40	48



"F" Series – Offset Helical ServoFit® Modular System Selection Data



Part Number	Reducer Ratio i		Input RPM			Backlash arcmins $\Delta\phi$ ¹⁾	Input Inertia J ₁ kgcm ²	Torsional Stiffness per arcmin C ₂		Output Torque					
			Maximum							Nominal ²⁾		Acceleration		Peak ³⁾	
	Nom.	Exact	n _{1DBH}	n _{1DBV}	n _{1ZB}			M _{2N} ≤ 2000 RPM		M _{2B}		M _{2PEAK}			
								Continuous	Cyclic	in.lbs.	Nm	in.lbs.	Nm	in.lbs.	Nm
F402 with MT TriAdapt® Motor Adapter															
Noise Level ≤ 53 dB(A)⁴⁾															
F402_0047 MT20	4.678	1408/301	2,700	2,300	4,000	10/7	16.0	88	9.9	1,608	182	1,769	200	2,683	303
F402_0047 MT30	4.678	1408/301	2,700	2,300	4,000	10/7	20.8	123	13.9	3,033	342	4,200	474	6,921	781
F402_0047 MT40	4.678	1408/301	2,700	2,300	3,500	10/7	24.8	186	21.0	3,033	342	4,872	550	6,921	781
F402_0058 MT20	5.813	3784/651	2,700	2,300	4,000	10/7	11.4	119	13.4	1,998	226	2,198	248	3,238	366
F402_0058 MT30	5.813	3784/651	2,700	2,300	4,000	10/7	16.2	159	17.9	3,260	368	4,872	550	8,353	943
F402_0058 MT40	5.813	3784/651	2,700	2,300	3,500	10/7	20.2	221	25.0	3,260	368	4,872	550	8,353	943
F402_0072 MT20	7.202	605/84	3,200	2,800	4,500	10/7	8.1	154	17.4	2,475	279	2,723	307	3,864	436
F402_0072 MT30	7.202	605/84	3,200	2,800	4,000	10/7	12.9	195	22.1	3,502	395	4,872	550	9,744	1,100
F402_0072 MT40	7.202	605/84	3,000	2,800	3,500	10/7	16.9	253	28.5	3,502	395	4,872	550	9,744	1,100
F402_0090 MT20	8.980	440/49	3,200	2,800	4,500	10/7	5.9	192	21.7	3,086	348	3,395	383	4,660	526
F402_0090 MT30	8.980	440/49	3,200	2,800	4,000	10/7	10.7	231	26.1	3,769	425	4,872	550	9,744	1,100
F402_0090 MT40	8.980	440/49	3,000	2,800	3,500	10/7	14.7	279	31.5	3,769	425	4,872	550	9,744	1,100
F402_0110 MT20	10.83	682/63	3,500	3,100	5,000	10/7	4.6	222	25.1	3,593	406	4,092	462	5,405	610
F402_0110 MT30	10.83	682/63	3,500	3,100	4,000	10/7	9.4	257	29.0	4,011	453	4,872	550	9,744	1,100
F402_0110 MT40	10.83	682/63	3,000	3,000	3,500	10/7	13.4	296	33.4	4,011	453	4,872	550	9,744	1,100
F402_0135 MT20	13.57	5984/441	3,500	3,100	5,000	10/7	3.5	255	28.8	3,941	445	4,872	550	6,552	740
F402_0135 MT30	13.57	5984/441	3,500	3,100	4,000	10/7	8.3	283	31.9	4,325	488	4,872	550	9,744	1,100
F402_0135 MT40	13.57	5984/441	3,000	3,000	3,500	10/7	12.3	311	35.2	4,325	488	4,872	550	9,744	1,100
F402_0185 MT20	18.62	3575/192	3,200	2,800	4,500	10/5	4.5	290	32.7	4,806	543	6,201	700	9,990	1,128
F402_0185 MT30	18.62	3575/192	3,200	2,800	4,000	10/5	9.3	308	34.8	4,806	543	6,201	700	12,401	1,400
F402_0185 MT40	18.62	3575/192	3,000	2,800	3,500	10/5	13.3	325	36.7	4,806	543	6,201	700	12,401	1,400
F402_0230 MT20	23.21	325/14	3,200	2,800	4,500	10/5	3.6	307	34.6	5,173	584	6,201	700	12,046	1,360
F402_0230 MT30	23.21	325/14	3,200	2,800	4,000	10/5	8.4	320	36.1	5,173	584	6,201	700	12,401	1,400
F402_0230 MT40	23.21	325/14	3,000	2,800	3,500	10/5	12.4	331	37.4	5,173	584	6,201	700	12,401	1,400
F402_0280 MT20	27.99	2015/72	3,500	3,100	5,000	10/5	3.0	317	35.8	5,505	622	6,201	700	12,401	1,400
F402_0280 MT30	27.99	2015/72	3,500	3,100	4,000	10/5	7.8	326	36.9	5,505	622	6,201	700	12,401	1,400
F402_0280 MT40	27.99	2015/72	3,000	3,000	3,500	10/5	11.8	335	37.8	5,505	622	6,201	700	12,401	1,400
F402_0350 MT20	35.08	2210/63	3,500	3,100	5,000	10/5	2.5	326	36.8	5,936	670	6,201	700	12,401	1,400
F402_0350 MT30	35.08	2210/63	3,500	3,100	4,000	10/5	7.3	332	37.5	5,936	670	6,201	700	12,401	1,400
F402_0350 MT40	35.08	2210/63	3,000	3,000	3,500	10/5	11.3	338	38.1	5,936	670	6,201	700	12,401	1,400
F402_0470 MT20	46.94	845/18	3,500	3,500	5,000	10/5	2.0	333	37.6	6,201	700	6,201	700	12,401	1,400
F402_0470 MT30	46.94	845/18	3,500	3,500	4,000	10/5	6.8	337	38.0	6,201	700	6,201	700	12,401	1,400
F402_0470 MT40	46.94	845/18	3,000	3,000	3,500	10/5	10.8	340	38.4	6,201	700	6,201	700	12,401	1,400
F402_0560 MT20	55.97	2015/36	3,500	3,500	5,000	10/5	1.8	336	37.9	6,201	700	6,201	700	12,401	1,400
F402_0560 MT30	55.97	2015/36	3,500	3,500	4,000	10/5	6.6	338	38.2	6,201	700	6,201	700	12,401	1,400
F402_0560 MT40	55.97	2015/36	3,000	3,000	3,500	10/5	10.6	341	38.5	6,201	700	6,201	700	12,401	1,400
F402_0700 MT20	70.06	1261/18	3,500	3,500	5,000	10/5	1.6	338	38.2	6,201	700	6,201	700	12,401	1,400
F402_0700 MT30	70.06	1261/18	3,500	3,500	4,000	10/5	6.4	340	38.4	6,201	700	6,201	700	12,401	1,400
F402_0700 MT40	70.06	1261/18	3,000	3,000	3,500	10/5	10.4	341	38.5	6,201	700	6,201	700	12,401	1,400
F402_0930 MT20	93.33	280/3	3,500	3,500	5,000	10/5	1.5	340	38.4	6,201	700	6,201	700	12,401	1,400
F402_0930 MT30	93.33	280/3	3,500	3,500	4,000	10/5	6.3	341	38.5	6,201	700	6,201	700	12,401	1,400
F402_1120 MT20	112.3	1235/11	3,500	3,500	5,000	10/5	1.4	341	38.5	6,201	700	6,201	700	12,401	1,400
F402_1120 MT30	112.3	1235/11	3,500	3,500	4,000	10/5	6.2	342	38.6	6,201	700	6,201	700	12,401	1,400
F402_1400 MT20	139.8	559/4	3,500	3,500	5,000	10/5	1.3	342	38.6	6,201	700	6,201	700	11,262	1,271



See Page 220 for Options and Part Number Configuration.



"F" Series – Offset Helical ServoFit® Modular System Selection Data



Part Number	Reducer Ratio i		Input RPM			Backlash arcmins $\Delta\phi$ ¹⁾	Input Inertia J ₁ kgcm ²	Torsional Stiffness per arcmin C ₂		Output Torque					
			Maximum							Nominal ²⁾		Acceleration		Peak ³⁾	
	Nom.	Exact	n _{1DBH}	n _{1DBV}	n _{1ZB}			M _{2N} ≤ 2000 RPM		M _{2B}		M _{2PEAK}			
			in.lbs.	Nm	in.lbs.			Nm	in.lbs.	Nm	in.lbs.	Nm			
F403 with MT TriAdapt® Motor Adapter															
Noise Level ≤ 53 dB(A) ⁴⁾															
F403_1820 MT20	181.5	4901/27	3,500	3,500	5,000	10/6	1.4	342	38.6	6,201	700	6,201	700	12,401	1,400
F403_1840 MT10	183.9	39715/216	3,800	3,500	5,500	10/6	0.7	342	38.6	6,201	700	6,201	700	8,334	941
F403_2160 MT20	216.4	11687/54	3,500	3,500	5,000	10/6	1.4	342	38.6	6,201	700	6,201	700	12,401	1,400
F403_2190 MT10	219.2	94705/432	3,800	3,500	5,500	10/6	0.7	342	38.6	6,201	700	6,201	700	9,937	1,122
F403_2710 MT20	270.9	36569/135	3,500	3,500	5,000	10/6	1.4	342	38.7	6,201	700	6,201	700	12,401	1,400
F403_2740 MT10	274.4	59267/216	3,800	3,500	5,500	10/6	0.7	342	38.7	6,201	700	6,201	700	12,401	1,400
F403_3610 MT20	360.9	3248/9	3,500	3,500	5,000	10/6	1.4	343	38.7	6,201	700	6,201	700	12,401	1,400
F403_3660 MT10	365.6	3290/9	3,800	3,500	5,500	10/6	0.7	343	38.7	6,201	700	6,201	700	12,401	1,400
F403_4340 MT20	434.1	14326/33	3,500	3,500	5,000	10/6	1.4	343	38.7	6,201	700	6,201	700	12,401	1,400
F403_4400 MT10	439.7	58045/132	3,800	3,500	5,500	10/6	0.7	343	38.7	6,201	700	6,201	700	12,401	1,400
F403_5470 MT10	547.4	26273/48	3,800	3,500	5,500	10/6	0.7	343	38.7	6,201	700	6,201	700	11,261	1,271
F602 with MT TriAdapt® Motor Adapter															
Continued Next Page															
Noise Level ≤ 61 dB(A) ⁴⁾															
F602_0045 MT30	4.546	1273/280	2,500	2,100	3,500	10/7	42.2	141	16.0	3,711	419	4,082	461	6,998	790
F602_0045 MT40	4.546	1273/280	2,500	2,100	3,500	10/7	46.2	240	27.1	5,020	567	5,598	632	6,998	790
F602_0057 MT30	5.673	1407/248	2,500	2,100	3,500	10/7	30.5	196	22.2	4,631	523	5,094	575	8,472	956
F602_0057 MT40	5.673	1407/248	2,500	2,100	3,500	10/7	34.5	310	34.9	5,405	610	6,778	765	8,472	956
F602_0072 MT30	7.159	3551/496	2,900	2,500	4,000	10/7	22.2	265	29.9	5,840	659	6,428	726	10,287	1,161
F602_0072 MT40	7.159	3551/496	2,900	2,500	3,500	10/7	26.2	384	43.3	5,840	659	8,230	929	10,287	1,161
F602_0090 MT20	8.995	1943/216	2,900	2,500	4,000	10/7	12.1	260	29.4	3,091	349	3,401	384	4,823	545
F602_0090 MT30	8.995	1943/216	2,900	2,500	4,000	10/7	16.9	338	38.1	6,302	711	8,077	912	12,440	1,404
F602_0090 MT40	8.995	1943/216	2,900	2,500	3,500	10/7	20.9	450	50.9	6,302	711	8,858	1,000	12,440	1,404
F602_0110 MT20	10.82	2077/192	3,300	2,800	4,500	10/7	9.1	319	36.0	3,718	420	4,090	462	5,632	636
F602_0110 MT30	10.82	2077/192	3,300	2,800	4,000	10/7	13.9	396	44.7	6,702	757	8,858	1,000	14,173	1,600
F602_0110 MT40	10.82	2077/192	3,000	2,800	3,500	10/7	17.9	497	56.1	6,702	757	8,858	1,000	14,173	1,600
F602_0135 MT20	13.61	871/64	3,300	2,800	4,500	10/7	6.6	392	44.2	4,451	502	5,145	581	6,770	764
F602_0135 MT30	13.61	871/64	3,300	2,800	4,000	10/7	11.4	461	52.1	7,235	817	8,858	1,000	14,173	1,600
F602_0135 MT40	13.61	871/64	3,000	2,800	3,500	10/7	15.4	542	61.2	7,235	817	8,858	1,000	14,173	1,600
F602_0185 MT30	18.52	3445/186	2,900	2,500	4,000	10/5	13.6	558	63.0	8,018	905	9,744	1,100	17,716	2,000
F602_0185 MT40	18.52	3445/186	2,900	2,500	3,500	10/5	17.6	619	69.8	8,018	905	9,744	1,100	17,716	2,000
F602_0230 MT20	23.27	1885/81	2,900	2,500	4,000	10/5	6.6	555	62.7	7,998	903	8,798	993	12,479	1,409
F602_0230 MT30	23.27	1885/81	2,900	2,500	4,000	10/5	11.4	599	67.6	8,652	977	9,744	1,100	17,716	2,000
F602_0230 MT40	23.27	1885/81	2,900	2,500	3,500	10/5	15.4	642	72.4	8,652	977	9,744	1,100	17,716	2,000
F602_0280 MT20	27.99	2015/72	3,300	2,800	4,500	10/5	5.4	590	66.6	9,200	1,039	9,744	1,100	14,571	1,645
F602_0280 MT30	27.99	2015/72	3,300	2,800	4,000	10/5	10.2	623	70.4	9,200	1,039	9,744	1,100	17,716	2,000
F602_0280 MT40	27.99	2015/72	3,000	2,800	3,500	10/5	14.2	654	73.9	9,200	1,039	9,744	1,100	17,716	2,000
F602_0350 MT20	35.21	845/24	3,300	2,800	4,500	10/5	4.2	622	70.2	9,744	1,100	9,744	1,100	17,514	1,977
F602_0350 MT30	35.21	845/24	3,300	2,800	4,000	10/5	9.0	645	72.8	9,744	1,100	9,744	1,100	17,716	2,000
F602_0350 MT40	35.21	845/24	3,000	2,800	3,500	10/5	13.0	666	75.1	9,744	1,100	9,744	1,100	17,716	2,000
F602_0470 MT20	46.72	1495/32	3,500	3,200	5,000	10/5	3.1	648	73.1	9,744	1,100	9,744	1,100	17,716	2,000
F602_0470 MT30	46.72	1495/32	3,500	3,200	4,000	10/5	7.9	662	74.7	9,744	1,100	9,744	1,100	17,716	2,000
F602_0470 MT40	46.72	1495/32	3,000	3,000	3,500	10/5	11.9	674	76.1	9,744	1,100	9,744	1,100	17,716	2,000
F602_0560 MT20	55.71	390/7	3,500	3,200	5,000	10/5	2.7	659	74.3	9,744	1,100	9,744	1,100	17,716	2,000
F602_0560 MT30	55.71	390/7	3,500	3,200	4,000	10/5	7.5	669	75.5	9,744	1,100	9,744	1,100	17,716	2,000
F602_0560 MT40	55.71	390/7	3,000	3,000	3,500	10/5	11.5	677	76.5	9,744	1,100	9,744	1,100	17,716	2,000
F602_0700 MT20	69.64	975/14	3,500	3,200	5,000	10/5	2.2	668	75.4	9,744	1,100	9,744	1,100	17,716	2,000
F602_0700 MT30	69.64	975/14	3,500	3,200	4,000	10/5	7.0	675	76.2	9,744	1,100	9,744	1,100	17,716	2,000
F602_0700 MT40	69.64	975/14	3,000	3,000	3,500	10/5	11.0	680	76.8	9,744	1,100	9,744	1,100	17,716	2,000

¹⁾ Backlash shown "STANDARD/REDUCED".

²⁾ Maximum torque for continuous input RPM - horizontal output position.

³⁾ Maximum momentary torque for emergency stops or heavy shock load. Admissible stops per life of reducer = 1,000 stops maximum.

⁴⁾ dB(A) Measured at 1 meter distance with 3000 RPM input.

Maximum Motor Shaft

Adapter	Diameter	Adapter	Diameter
MT10	19	MT30	38
MT20	24	MT40	48



"F" Series – Offset Helical ServoFit® Modular System Selection Data



Part Number	Reducer Ratio i		Input RPM			Backlash arcmins $\Delta\phi$ ¹⁾	Input Inertia J ₁ kgcm ²	Torsional Stiffness per arcmin C ₂		Output Torque					
			Maximum							Nominal ²⁾		Acceleration		Peak ³⁾	
	Nom.	Exact	n _{1DBH}	n _{1DBV}	n _{1ZB}			M _{2N} ≤ 2000 RPM		M _{2B}		M _{2PEAK}			
								Continuous	Cyclic	in.lbs.	Nm	in.lbs.	Nm	in.lbs.	Nm
F602 with MT TriAdapt® Motor Adapter <i>Continued</i>										Noise Level ≤ 53 dB(A) ⁴⁾					
F602_0930 MT20	93.33	280/3	3,500	3,200	5,000	10/5	1.8	676	76.3	9,744	1,100	9,744	1,100	17,716	2,000
F602_0930 MT30	93.33	280/3	3,500	3,200	4,000	10/5	6.6	679	76.7	9,744	1,100	9,744	1,100	17,716	2,000
F602_0930 MT40	93.33	280/3	3,000	3,000	3,500	10/5	10.6	683	77.1	9,744	1,100	9,744	1,100	17,716	2,000
F602_1120 MT20	112.2	9425/84	3,500	3,200	5,000	10/5	1.6	679	76.6	9,744	1,100	9,744	1,100	17,716	2,000
F602_1120 MT30	112.2	9425/84	3,500	3,200	4,000	10/5	6.4	681	76.9	9,744	1,100	9,744	1,100	17,716	2,000
F602_1400 MT20	139.8	559/4	3,500	3,200	5,000	10/5	1.5	681	76.9	9,744	1,100	9,744	1,100	17,716	2,000
F602_1400 MT30	139.8	559/4	3,500	3,200	4,000	10/5	6.3	683	77.1	9,744	1,100	9,744	1,100	17,716	2,000
F603 with MT TriAdapt® Motor Adapter										Noise Level ≤ 61 dB(A) ⁴⁾					
F603_1810 MT20	180.6	8671/48	3,500	3,200	5,000	10/6	1.5	683	77.1	9,744	1,100	9,744	1,100	17,716	2,000
F603_2150 MT20	215.4	1508/7	3,500	3,200	5,000	10/6	1.5	684	77.2	9,744	1,100	9,744	1,100	17,716	2,000
F603_2690 MT20	269.3	1885/7	3,500	3,200	5,000	10/6	1.4	684	77.2	9,744	1,100	9,744	1,100	17,716	2,000
F603_3610 MT20	360.9	3248/9	3,500	3,200	5,000	10/6	1.4	685	77.3	9,744	1,100	9,744	1,100	17,716	2,000
F603_4340 MT20	433.8	54665/126	3,500	3,200	5,000	10/6	1.4	685	77.3	9,744	1,100	9,744	1,100	17,716	2,000
F603_5400 MT20	540.4	16211/30	3,500	3,200	5,000	10/6	1.4	685	77.3	9,744	1,100	9,744	1,100	17,716	2,000



See Page 220 for Options and Part Number Configuration.

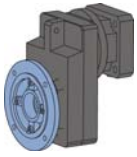

ServoFit® "F" Series – Offset Helical Round Flange – "F" Housing Hollow Output – Dimensional Data

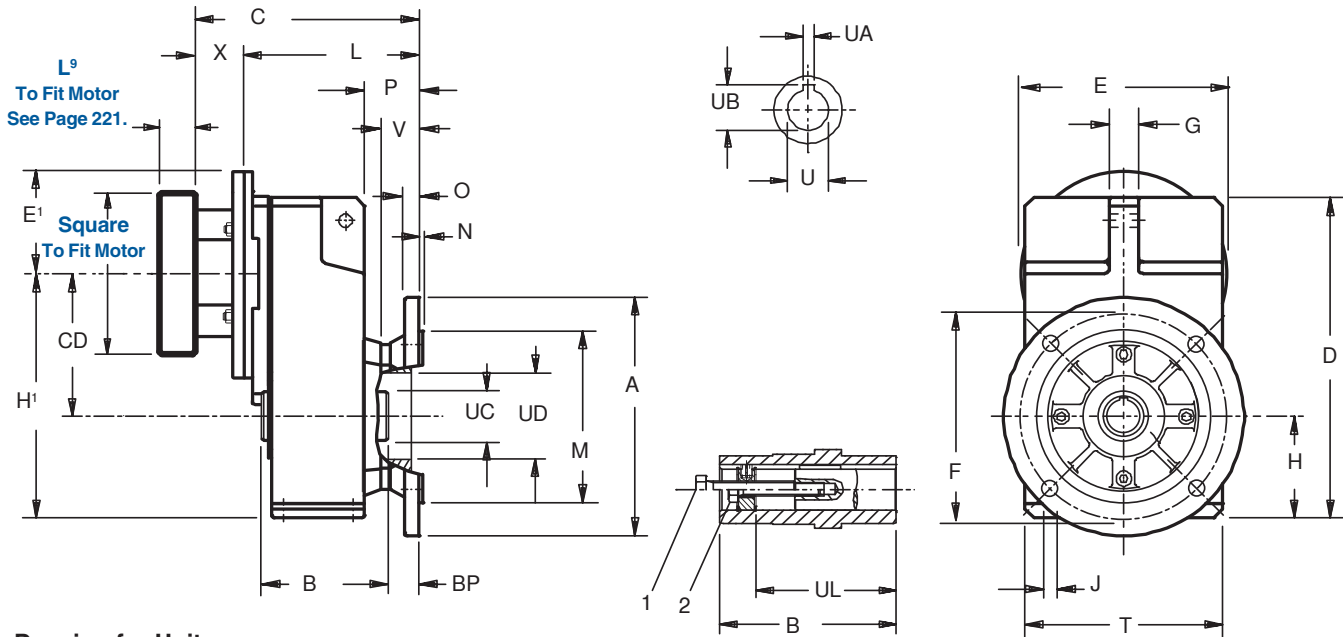

Drawing for Units
F102AF — F603AF

See Page 298 for installation of hollow output.

Table No. 1 "F" Series – Round Flange Unit Dimensions (mm) – "F" Housing Style

Base Module	CD	A	B	D	F	G	H	H'	J	M _{je}	N	O	P	T	BP	UC	UD	UL
F102	102	125	95	238	130	20	74	176	9	110	3.5	10	44.5	145	25.5	35	52	73
F202/F203	131	150	115	299	165	22	936	224	11	130	3.5	14	53	180	30	45	65	92
F302/F303	149.5	200	130	335.5	215	30	106	255.5	14	180	4	15	56.5	206	31.5	50	72	103
F402/F403	169 ¹⁾	200	145	370	215	30	116	285 ¹⁾	14	180	4	15	56.5	230	31.5	55	72	114
F602/F603	196	250	180	433	265	35	137	333	14	230	4	17	60.5	265	29.5	70	80	143

¹⁾ C.D. is 132 for F403 with MT20; H' is 248.

Table No. 2 Metric output available on request

Base Module	Standard Bore - inches			Optional Bore - mm		
	U	UA	UB	U	UA	UB
F102	.750 _{G7}	.187	.84	20 _{H7}	6 _{JS9}	22.8
F202/F203	1.000 _{G7}	.250	1.12	25 _{H7}	8 _{JS9}	28.3
F302/F303	1.250 _{G7}	.250	1.37	30 _{H7}	8 _{JS9}	33.3
F402/F403	1.500 _{G7}	.375	1.67	40 _{H7}	12 _{JS9}	43.3
F602/F603	2.000 _{G7}	.500	2.23	50 _{H7}	14 _{JS9}	53.8

Table No. 4 Motor Adapter Dimensions (mm)

Motor Adapter	Motor Shaft D ⁶ Max. ¹⁾	Thickness ²⁾ L ⁹ Min.	E	E ²	X	Wt. lbs.
MT10	19	21	140	70	40	5
MT20	24	24	160	80	50	8
MT30	38	25	200	100	60	12
MT40	48	33	250	125	89	18

¹⁾ If an adapter bushing is required it will be supplied as a component of the motor mounting plate.

²⁾ Motor plate maximum thickness (L⁹) will vary with motor shaft length but will not be less than shown.

1. Removal Bolt – not supplied. See Page 298.

2. Mounting Bolt – must be smaller than removal bolt.

For approximate weight, add base module weight from Table 3 and adapter weight from Table 4.

Table No. 3

"F" Series – Unit Dimensions (mm) – "F" Housing Style

Base Module	MT10		MT20		MT30		MT40		Approx. Wt. lbs.
	C	L	C	L	C	L	C	L	
F102	173	133	187	137	–	–	–	–	38
F202	196.5	156.5	210.5	160.5	216.5	156.5	–	–	51
F203	233.5	193.5	–	–	–	–	–	–	64
F302	213.5	173.5	227.5	177.5	239.5	179.5	–	–	67
F303	250.5	210.5	270.5	220.5	–	–	–	–	73
F402	–	–	242.5	192.5	254.5	194.5	286.5	197.5	84
F403	265.5	225.5	285.5	235.5	–	–	–	–	91
F602	–	–	273.5	223.5	285.5	225.5	317.5	228.5	165
F603	–	–	316.5	266.5	–	–	–	–	177

Part No. Example

Round Flange Unit with TriAdapt® Motor Adapter

F302AF0620 MT20



ServoFit® "F" Series – Offset Helical Round Flange – "F" Housing Shaft Output – Dimensional Data

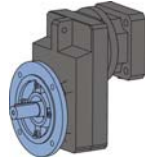

NOTE: Solid output shaft is ONLY available with an output flange.

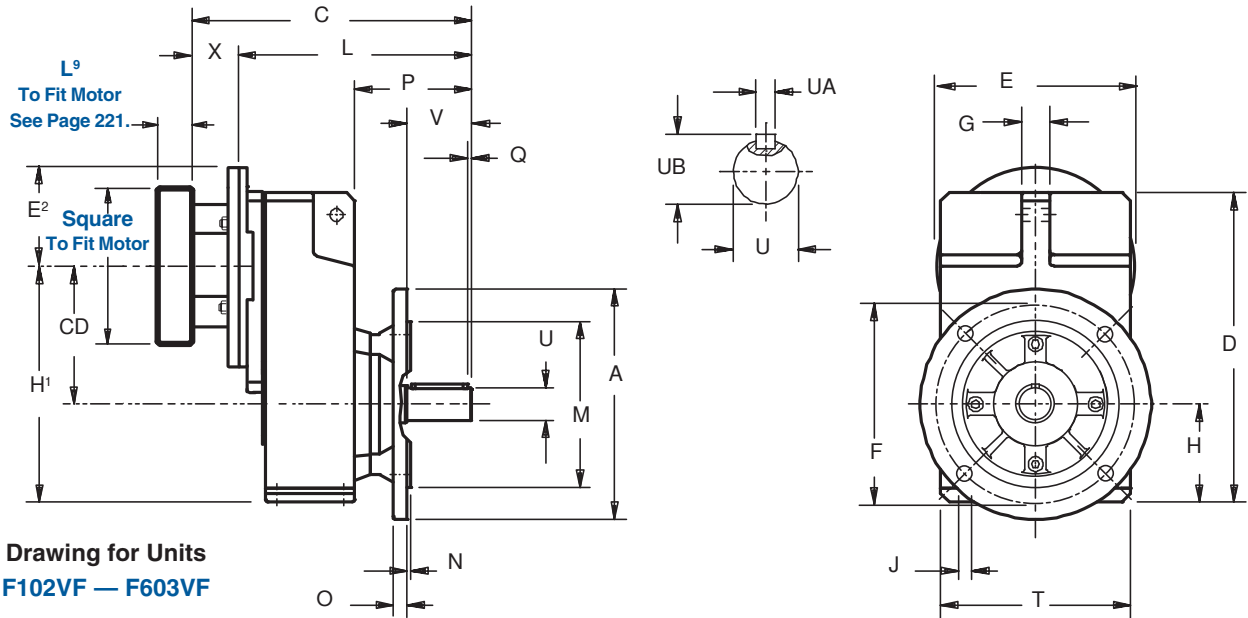

Drawing for Units
F102VF – F603VF

Table No. 1 "F" Series – Round Flange Unit Dimensions (mm) – "F" Housing Style

Base Module	CD	A	D	F	G	H	H ¹	J	M ₆	N	O	P	Q	T	V
F102	102	125	238	130	20	74	176	9	110	3.5	10	94.5	5	145	50
F202/F203	131	150	299	165	22	936	224	11	130	3.5	14	113	5	180	60
F302/F303	149.5	200	335.5	215	30	106	255.5	14	180	4	15	126.5	5	206	70
F402/F403	169 ¹⁾	200	370	215	30	116	285 ¹⁾	14	180	4	15	136.5	5	230	80
F602/F603	196	250	433	265	35	137	333	14	230	4	17	160.5	5	265	100

¹⁾ C.D. is 132 for F403 with MT20; H¹ is 248.

Table No. 2 Metric output available on request

Base Module	Standard Shaft - inches			Optional Shaft - mm		
	U	UA	UB	U	UA	UB
F102	1.000 _{h6}	1/4 × 1/4 × 1 ⁹ / ₁₆	1.11	25 _{k6}	A8x7x40	28
F202/F203	1.250 _{h6}	1/4 × 1/4 × 1 ¹⁵ / ₁₆	1.36	30 _{k6}	A8x7x50	33
F302/F303	1.375 _{h6}	5/16 × 5/16 × 2 ⁵ / ₁₆	1.51	35 _{k6}	A10x8X60	38
F402/F403	1.625 _{h6}	3/8 × 3/8 × 2 ⁷ / ₈	1.79	40 _{k6}	A12x8X70	43
F602/F603	2.125 _{h6}	1/2 × 1/2 × 3 ⁵ / ₃₂	2.35	50 _{k6}	A14x9X90	53.5

Table No. 4 Motor Adapter Dimensions (mm)

Motor Adapter	Motor Shaft D ⁶ Max. ¹⁾	Thickness ²⁾ L ⁹ Min.	E	E ²	X	Wt. lbs.
MT10	19	21	140	70	40	5
MT20	24	24	160	80	50	8
MT30	38	25	200	100	60	12
MT40	48	33	250	125	89	18

¹⁾ If an adapter bushing is required it will be supplied as a component of the motor mounting plate.

²⁾ Motor plate maximum thickness (L⁹) will vary with motor shaft length but will not be less than shown.

For approximate weight, add base module weight from Table 3 and adapter weight from Table 4.

Table No. 3

"F" Series – Unit Dimensions (mm) – "F" Housing Style

Base Module	MT10		MT20		MT30		MT40		Approx. Wt. lbs.
	C	L	C	L	C	L	C	L	
F102	219.5	179.5	233.5	103.5	–	–	–	–	38
F202	253	213	267	217	279	219	–	–	51
F203	290	250	–	–	–	–	–	–	64
F302	279.5	239.5	293.5	243.5	305.5	245.5	–	–	67
F303	316.5	276.5	336.5	286.5	–	–	–	–	73
F402	–	–	318.5	268.5	330.5	270.5	362.5	273.5	84
F403	341.5	301.5	361.5	311.5	–	–	–	–	91
F602	–	–	369.5	319.5	381.5	321.5	413.5	324.5	165
F603	–	–	412.5	362.5	–	–	–	–	177

Part No. Example

Round Flange with TriAdapt® Motor Adapter

F302VF0620 MT20

See Page 220 for Options and Part Number Configuration.

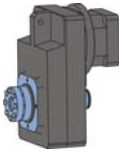

ServoFit® "F" Series – Offset Helical Tapped Hole – "G" Housing Single Bushing – Dimensional Data

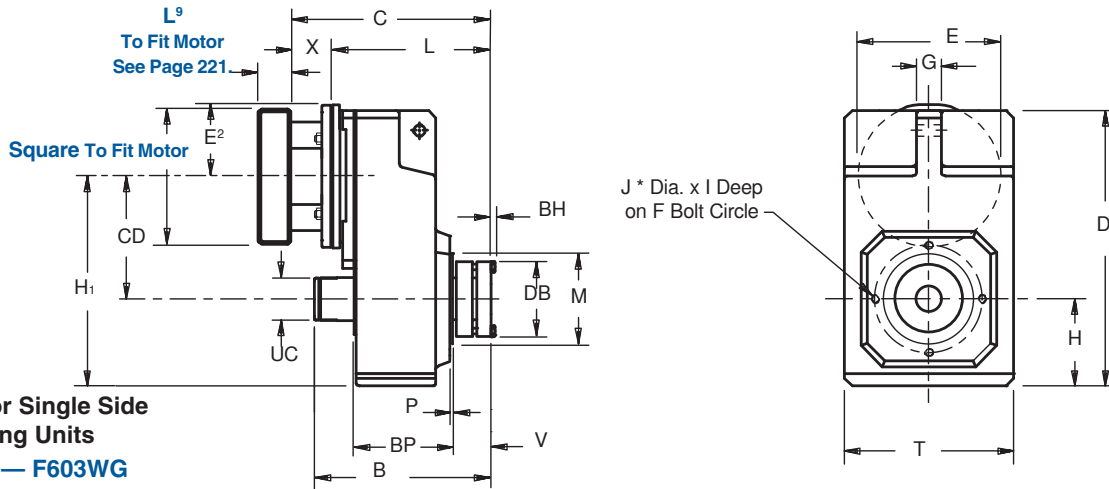

Drawing for Single Side Bushing Units
F102WG – F603WG

Important: For ease of installation, a 1/32 x 45° chamfer (minimum) is recommended for the output shaft end.

Table No. 1 "F" Series – Single Side Wobble Free Bushing Unit Dimensions (mm)

Base Module	CD	B	D	F	G	H	H ₁	I	J *	M ₁₆	P	T	V	BH	BP	DB	UC	Bushing Capscrews	
																		No. — Size Metric	Tightening Torque — Nm
F102	102	162.5	238	90	20	74	176	13	M8	75	2.5	145	30	4	87	68	34.5	6 — M6x25	10
F202/F203	131	184.5	299	165	22	93	224	13	M8	95	3	180	39	4	105	78	44.5	8 — M6x30	10
F302/F303	149.5	202	335.5	215	30	106	255.5	16	M10	110	3.5	206	39	4	120	84	48	8 — M6x30	10
F402/F403	169 ¹⁾	227	370	215	30	116	285 ¹⁾	16	M10	110	3.5	230	45	5	135	97	54.5	8 — M8x30	25
F602/F603	196	260	433	265	35	137	333	16	M10	130	3.5	265	50	6	166	105	64.5	8 — M10x35	49

*F602 and F603 has 8 tapped holes instead of 4 as shown on drawing.

¹⁾ C.D. is 132 for F403 with MT20; H₁ is 248.

Table No. 2 Motor Adapter Dimensions (mm)

Motor Adapter	Motor Shaft D ⁶ Max. ¹⁾	Thickness ²⁾ L ⁹ Min.	E	E ²	X	Wt. lbs.
MT10	19	21	140	70	40	5
MT20	24	24	160	80	50	8
MT30	38	25	200	100	60	12
MT40	48	33	250	125	89	18

¹⁾ If an adapter bushing is required it will be supplied as a component of the motor mounting plate.

²⁾ Motor plate maximum thickness (L⁹) will vary with motor shaft length but will not be less than shown.

Table No. 3 "WF" Bushing Single Side without Covers – Metric

Unit	Stock Bores Sizes		
	20	30	35
F102	WF1-20	—	—
F202	—	WF2-30	—
F302	—	WF3-30	WF3-35

Table No. 4 "F" Series – "G" Housing Style

Base Module	MT10		MT20		MT30		MT40		Approx. Wt. lbs.
	C	L	C	L	C	L	C	L	
F102	170	130	184	134	—	—	—	—	38
F202	197	157	211	161	223	163	—	—	51
F203	234	194	—	—	—	—	—	—	64
F302	212	172	226	176	238	178	—	—	67
F303	249	209	269	219	—	—	—	—	73
F402	—	—	247	197	259	199	291	202	84
F403	270	230	290	240	—	—	—	—	91
F602	—	—	278	228	290	230	322	233	165
F603	—	—	321	271	—	—	—	—	177

Part No. Example

Unit with TriAdapt® Motor Adapter, 1 3/8" Bore, Single Bushing
F402WG0560 MT20 WF4-106

A complete bushing kit includes the locking ring assembly, tapered cone, support ring, and all hardware to mount the kit into the reducer.

The bushing will accept a shaft with a tolerance of +.000/-0.005.

NOTE: F6 units use a WF5 Bushing Kit.

Table No. 5 "WF" Single Side Bushings – Inches

Base Module	Stock Bores Sizes													
	3/4	1	1 1/16	1 1/4	1 3/8	1 7/16	1 1/2	1 5/8	1 11/16	1 3/4	1 7/8	1 15/16	2	
F102	WF1-075	—	—	—	—	—	—	—	—	—	—	—	—	
F202/F203	—	WF2-100	WF2-103	—	—	—	—	—	—	—	—	—	—	
F302/F303	—	WF3-100	WF3-103	WF3-104	WF3-106	WF3-107	WF3-108	—	—	—	—	—	—	
F402/F403	—	WF4-100	WF4-103	WF4-104	WF4-106	WF4-107	WF4-108	—	—	—	—	—	—	
F602/F603	—	—	—	—	—	WF5-107	WF5-108	WF5-110	WF5-111	WF5-112	WF5-114	WF5-115	WF5-200	

For an approximate unit weight, add the weights in Table 2 and Table 4.



ServoFit® "F" Series – Offset Helical Tapped Hole – "G" Housing Double Bushing – Dimensional Data

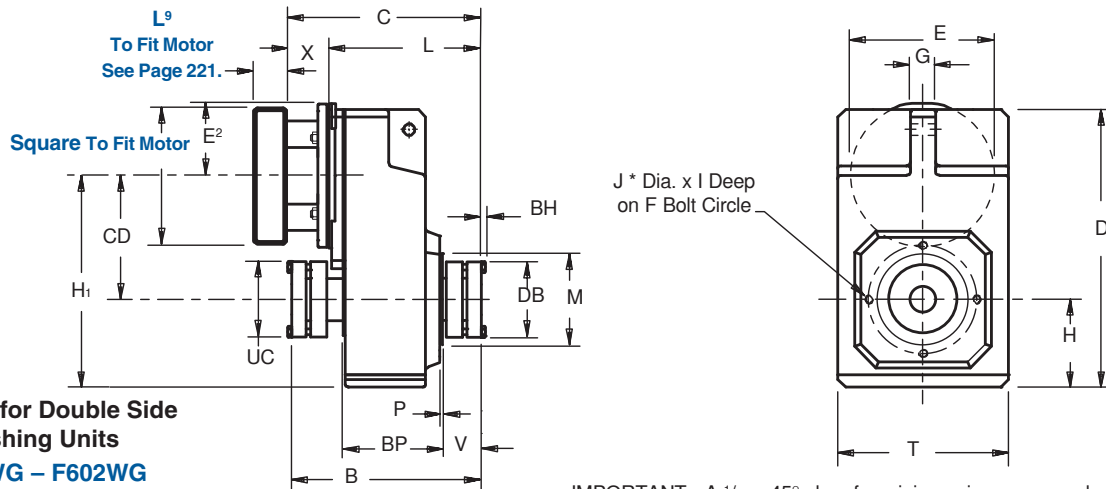
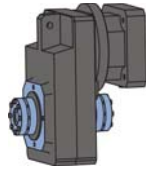

Drawing for Double Side Bushing Units
F102WG – F602WG

IMPORTANT: A 1/32 x 45° chamfer minimum is recommended for the shaft end.
The bushing will accept a shaft with a tolerance of +.000/-0.005 inches.
The double bushing cannot be mounted in sizes F203, F303, F403, or F603.

Table No. 1 "F" Series – Double Side Wobble Free Bushing Unit Dimensions (Inches)

Base Module	CD	B	D	F	G	H	H ₁	I	J *	M _{js}	P	T	V	BH	BP	DB	Bushing Capscrews	
																	No.—Size Metric	Tightening Torque—Nm
F102	102	162.5	238	90	20	74	176	13	M8	75	2.5	145	30	4	87	68	6—M6x25	10
F202	131	184.5	299	165	22	93	224	13	M8	95	3	180	39	4	105	78	8—M6x30	10
F302	149.5	202	335.5	215	30	106	255.5	16	M10	110	3.5	206	39	4	120	84	8—M6x30	10
F402	169 ¹⁾	227	370	215	30	116	285 ¹⁾	16	M10	110	3.5	230	45	5	135	97	8—M8x30	25
F602	196	260	433	265	35	137	333	16	M10	130	3.5	265	50	6	166	105	8—M10x35	49

*F602 has 8 tapped holes instead of 4 as shown on drawing.
¹⁾ C.D. is 132 for F403 with MT20; H₁ is 248.

Table No. 2 Motor Adapter Dimensions (mm)

Motor Adapter	Motor Shaft D ⁶ Max. ¹⁾	Thickness ²⁾ L ⁹ Min.	E	E ²	X	Wt. lbs.
MT10	19	21	140	70	40	5
MT20	24	24	160	80	50	8
MT30	38	25	200	100	60	12
MT40	48	33	250	125	89	18

¹⁾ If an adapter bushing is required it will be supplied as a component of the motor mounting plate.
²⁾ Motor plate maximum thickness (L⁹) will vary with motor shaft length but will not be less than shown.

Table No. 3 "WFN" Bushing Double Side without Covers – Metric

Unit	Stock Bores Sizes			
	20	30	35	40
F102	WFN1-20	—	—	—
F202	—	WFN2-30	—	—
F302	—	WFN3-30	WFN3-35	—
F402	—	—	—	WFN4-40
F602	—	—	—	WFN5-40

Table No. 4 "F" Series – "G" Housing Style

Base Module	MT10		MT20		MT30		MT40		Approx. Wt. lbs.
	C	L	C	L	C	L	C	L	
F102	170	130	184	134	—	—	—	—	38
F202	197	157	211	161	223	163	—	—	51
F302	212	172	226	176	238	178	—	—	67
F402	—	—	247	197	259	199	291	202	84
F602	—	—	278	228	290	230	322	233	165

Part No. Explanation

Unit with TriAdapt® Motor Adapter 1 3/8" Bore Double Bushing
F402WG0560 MT20 WFN4-106

A complete bushing kit includes the locking ring assembly, tapered cone, support ring, and all hardware to mount the kit into the reducer.
The bushing will accept a shaft with a tolerance of +.000/-0.005.

NOTE: F6 units use a WFN5 Bushing Kit.

Table No. 5 "WFN" Double Side Bushings without Covers – Inches

Unit	Stock Bores Sizes													
	3/4	1	1 3/16	1 1/4	1 3/8	1 7/16	1 1/2	1 5/8	1 11/16	1 3/4	1 7/8	1 15/16	2	
F102	WFN1-075	—	—	—	—	—	—	—	—	—	—	—	—	
F202	—	WFN2-100	WFN2-103	—	—	—	—	—	—	—	—	—	—	
F302	—	WFN3-100	WFN3-103	WFN3-104	WFN3-106	WFN3-107	WFN3-108	—	—	—	—	—	—	
F402	—	WFN4-100	WFN4-103	WFN4-104	WFN4-106	WFN4-107	WFN4-108	—	—	—	—	—	—	
F602	—	—	—	—	—	WFN5-107	WFN5-108	WFN5-110	WFN5-111	WFN5-112	WFN5-114	WFN5-115	WFN5-200	

For an approximate unit weight, add the weights in Table 2 and Table 4.



ServoFit® "F" Series – Offset Helical Tapped Hole – "G" Housing Hollow Output – Dimensional Data

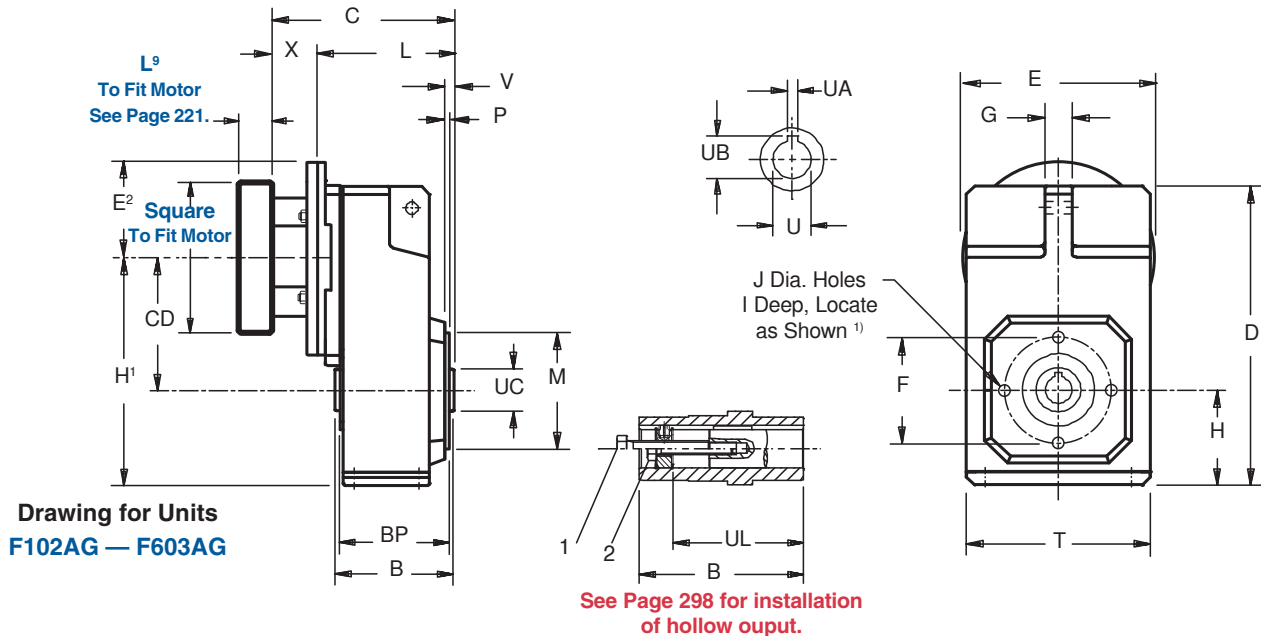

Table No. 1 "F" Series – Tapped Holes Unit Dimensions (mm) – "G" Housing Style

Base Module	CD	B	D	F	G	H	H ¹	I	J ¹⁾	M _{J6}	P	T	V	BP	UC	UL
F102	102	95	238	130	20	74	176	13	4-M8	70	2.5	145	6.5	87	35	73
F202/F203	131	115	299	165	22	93	224	13	4-M8	95	3	180	8	105	45	92
F302/F303	149.5	130	335.5	215	30	106	255.5	16	4-M10	110	3.5	206	8.5	120	50	103
F402/F403	169 ²⁾	145	370	215	30	116	285 ²⁾	16	4-M10	110	3.5	230	8.5	135	55	114
F602/F603	196	180	433	265	35	137	333	16	8-M10	130	3.5	265	10.5	166	70	143

¹⁾F602 and F603 has 8 tapped holes located 22.5° from horizontal instead of 4 as shown on drawing.

²⁾ C.D. is 132 and H¹ is 248 for F403 with MT20.

Table No. 2 Metric output available on request

Base Module	Standard Bore - inches			Optional Bore - mm		
	U	UA	UB	U	UA	UB
F102	.750	.187	.84	20 _{H7}	6 _{JS9}	22.8
F202/F203	1.000	.250	1.12	25 _{H7}	8 _{JS9}	28.3
F302/F303	1.250	.250	1.37	30 _{H7}	8 _{JS9}	33.3
F402/F403	1.500	.375	1.67	40 _{H7}	12 _{JS9}	43.3
F602/F603	2.000	.500	2.23	50 _{H7}	14 _{JS9}	53.8

Table No. 4 Motor Adapter Dimensions (mm)

Motor Adapter	Motor Shaft D ⁶ Max. ¹⁾	Thickness ²⁾ L ⁹ Min.	E	E ²	X	Wt. lbs.
MT10	19	21	140	70	40	5
MT20	24	24	160	80	50	8
MT30	38	25	200	100	60	12
MT40	48	33	250	125	89	18

¹⁾ If an adapter bushing is required it will be supplied as a component of the motor mounting plate.

²⁾ Motor plate maximum thickness (L⁹) will vary with motor shaft length but will not be less than shown.

1. Removal Bolt – not supplied.

2. Mounting Bolt – must be smaller than removal bolt. See Page 298.

For approximate weight, add base module weight from Table 3 and adapter weight from Table 4.

Table No. 3 "F" Series – Dimensions (mm)

Base Module	MT10		MT20		MT30		MT40		Approx. Wt. lbs.
	C	L	C	L	C	L	C	L	
F102	144	104	158	108	–	–	–	–	38
F202	163	123	177	127	189	129	–	–	51
F203	200	160	–	–	–	–	–	–	64
F302	178	138	192	142	204	144	–	–	67
F303	215	175	235	185	–	–	–	–	73
F402	–	–	207	157	219	159	251	162	84
F403	230	190	250	200	–	–	–	–	91
F602	–	–	240	190	252	192	284	195	165
F603	–	–	283	233	–	–	–	–	177

Part No. Example

Tapped Holes Housing with TriAdapt® Motor Adapter

F302AG0620 MT20

See Page 220 for Options and Part Number Configuration.

ServoFit® "F" Series – Offset Helical Tapped Hole – “GN” Housing Hollow Output – Dimensional Data

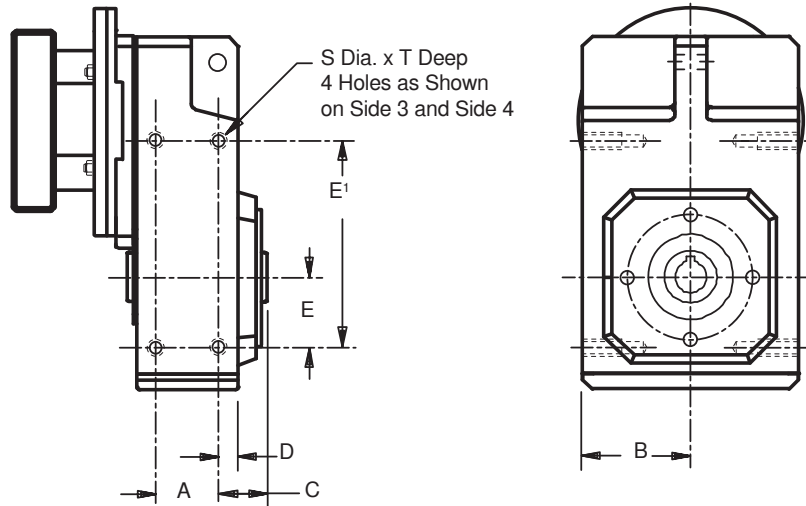

Table No. 1

"F" Series – Foot Mount “GN” Housing Dimensions (mm)

Base Module	A	B	C	D	E	E'	S	T
F102/F103	50	71	29	10	40	140	M6	11
F202/F203	64	88	33.5	10.5	55	175	M8	13
F302/F303	72	102	37.5	12.5	60	200	M10	16
F402/F403	87	144	37.5	12.5	70	220	M10	16
F602/F603	108	131	46.5	15.5	85	270	M12	19

F

Rubber Buffer – Dimensional Data

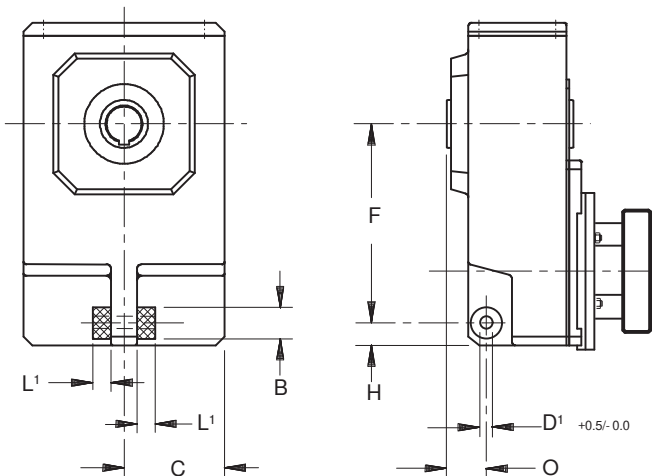

Table No. 2

"F" Series — Rubber Buffer Dimensions (mm)

Base Module	Part No.	B	C	F	H	D'1	L'1	O
F102/F103	25192	30	72.5	150	14	11	15	35
F202/F203	25192	30	90	181	25	11	15	40
F302/F303	25193	40	103	205	24.5	12.5	20	45
F402/F403	25193	40	115	228	26	12.5	20	45
F602/F603	25194	60	137.5	270	26	21	30	55

Order two (2) rubber buffers for each unit.
Torque arms are not supplied by STOBER.



"K" Series – Right Angle Helical/Bevel ServoFit® Modular System

Right angle helical/bevel gear drives offer higher input-to-output efficiencies than conventional worm gear drives or right angle planetary gearheads—making them the optimal drive for truly demanding continuous applications.

Performance Specifications:

- Input RPM up to 4,500 RPM
- Nominal output torque — 109 to 106,000 in. lbs. (12-11,900Nm)
- Reducer ratios from 4:1 to 381:1
- 5 year limited warranty (2 years on bearings, seals, etc.)
- Ambient temperature — 0° C to +40° C (104° F) [Unit temperature ≤ 80° C Max.]
- Noise level — as low as 53 dB(A)
- Maintenance free
- Can be back driven

One-piece cast iron housing with precision machined bearing supports assure gearset alignment, prolongs bearing life, provides exceptional overhung load capacities, and eliminates leakage problems common to drives with bolt-on output covers.

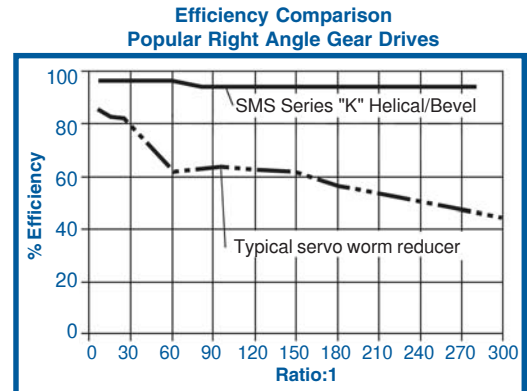

High efficiency spiral bevel gearing provides quiet operation and excellent torque carrying capacity

Double lip seals keep oil in and contaminants out. Double seals available for severe duty applications.

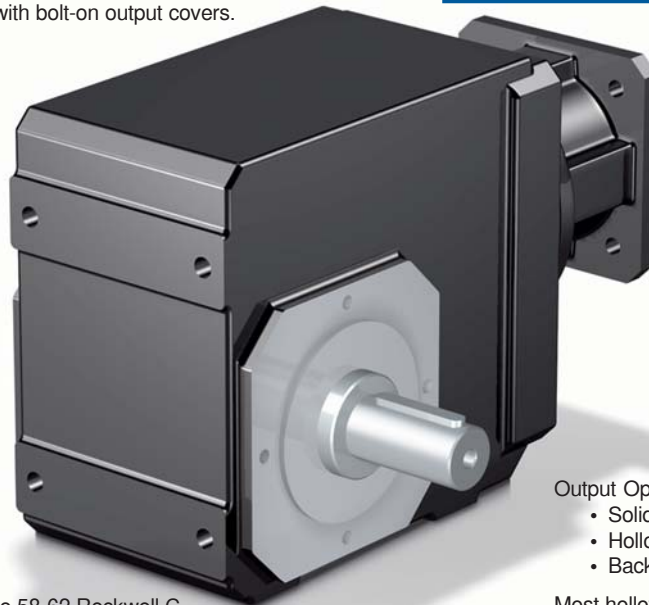

Motor plate can easily be changed to fit your choice of motors.

Custom motor plates supplied in 10 working days maximum.

Output Options:

- Solid shaft
- Hollow
- Backlash free, wobble free bushings

High quality helical gearing is case hardened to 58-62 Rockwell C.

Precision finished for low noise and long service life. When the backlash is set by our manufacturing and assemble methods it remains consistent throughout the life of the reducer without further need for adjustment.

Standard backlash is ≤12 arc minutes. Reduced backlash is ≤6 arc minutes

Most hollow output and solid shafts are available metric and also stainless steel for washdown, food duty, and beverage duty.

Shipped with the proper amount of oil to prevent gear damaging dry start-ups.

Introducing "KL" Series

- Compact
- Symmetrical
- Nominal output torque — 130 to 443 in. lbs. (15-50Nm)
- Reducer ratios from 4:1 to 32:1
- Maintenance free

Size comparison of KL102 and K102

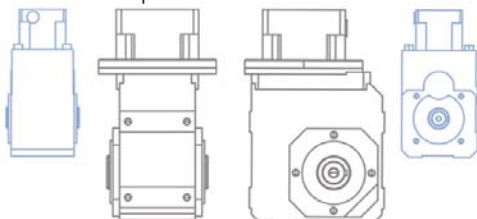









K

“K” Series – Right Angle Helical/Bevel ServoFit® Modular System



Part No. Explanation

K **6** **1** **3** **A** **GD** **0580** **MT40** **B**

Series	Size	Generation	No. of Gear Stages	Output Style	Housing Style	Ratio:1	Motor Adapter	Beverage Duty Option
Series	<u>K</u>	Right Angle Helical/Bevel (output is at a right angle to input; gears are helical and spiral bevel)						
Size	<u>6</u>	Sizes available: KL1, KL2, K1, K2, K3, K4, K5, <u>K6</u> , K7, K8, K9, K10						
Generation	<u>1</u>	Design generation: first generation 0, second generation <u>1</u> , etc.						
No. of Gear Stages	<u>3</u>	Number of gear stages: 2, <u>3</u> , 4 (determined by the ratio)						
Output Style	<u>A</u>	Hollow output  Available: imperial, metric, and stainless steel in most sizes.						
	<u>S</u>	Shrink Ring output  SPECIFY: Side 3 or Side 4.						
	<u>V</u>	Shaft output  SPECIFY: Shaft Side 3 or Side 4 (shown). Available: imperial, metric, and stainless steel in most sizes.						
	KL ONLY: <u>P</u>	Shaft output <u>with</u> a key						
	<u>G</u>	Shaft output <u>without</u> a key						
	<u>W</u>	Single or double wobble free bushing output  IF Single Bushing — SPECIFY: Side 3 or Side 4 (shown).						
Housing Style	<u>GD</u>	Torque arm bucket mounting  SPECIFY: Side 1 or Side 5 (also Side 2 on K1).						
	<u>F</u>	Output flange  SPECIFY: Side 3 or Side 4 (shown).						
	<u>G</u>	Tapped holes on the both sides of the output 						
	<u>N</u>	Foot mounting  SPECIFY: Side 1 (shown) or Side 5 (also Side 2 on K1).						
Ratio	<u>0580</u>	Approximate ratio: <u>0580</u> = 58.297:1 (4:1 up to 381:1)						
Motor Adapter	<u>MT40</u>	Motor adapter size from Selection Data: MT10, MT20, MT30, <u>MT40</u> , MT50 (Motor information must be specified.)						
Option	<u>B</u>	Add when ordering the Beverage Duty option.						
	<u>F</u>	Add when ordering the Food Duty option.						

Specify these options ONLY when deviating from STANDARD:

- Output — Inches (standard) or Metric (not available in all sizes)
- Output Material — Stainless (not available in all sizes)
- Backlash — Reduced
- Paint—Black (standard), White, or Stainless
- Oil—Mobilgear 600XP220 (standard), Food grade (Mobil SHC CIBUS 220) or Synthetic (Mobil SHC630)



“K” Series – Right Angle Helical/Bevel ServoFit® Modular System

Mounting Positions – Must be Specified

K1 – K4

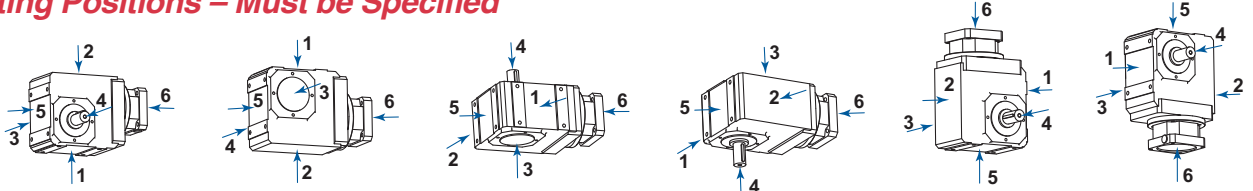

K5 – K10

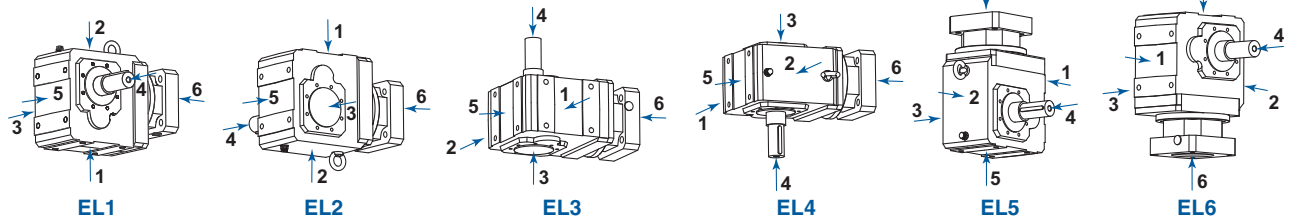

“K” units have the shaft on Side 3 and/or Side 4 (shown). **Shaft side must be specified.**

- EL1** Side 1 is the bottom side when the unit is set in a normal position. Side 1 is the down side for EL1.
- EL2** Side 2 is the top of the unit. Side 2 is the down side for EL2 . (The unit is up-side-down.)
- EL3** Side 3 is the right side when facing the input with the unit in a normal position (EL1). Side 3 is the down side for EL3.
- EL4** Side 4 is the left side when facing the input with the unit in a normal position (EL1). Side 4 is the down side for EL4.
- EL5** Side 5 is the side opposite the motor. Side 5 is the down side for EL5.
- EL6** Side 6 is the input or motor side. Side 6 is the down side for EL6.

DO NOT MOUNT any STOBER reducer in a position other than specified on the order.

All STOBER units are filled with the correct amount of lubrication before shipping. In order to provide the proper lubrication quantity **the mounting position must be specified at the time the unit is ordered.** Our web site: <http://www.stober.com/pages/lubrication-quantity> list the oil quantity for each size and mounting position.

Motor Mounting Specifications

STOBER ServoFit Gearheads will fit the motor of your choice by assembling the correct motor mounting plate between the motor and the gearhead. **When ordering a gearhead, specify the motor manufacturer and part number, provide the motor drawing with dimensions, or specify the motor mounting dimensions.** The motor plate thickness (L^9) dimension will be determined by the motor shaft length. The minimum motor plate thickness is shown below. For a precise dimension on a specific motor, contact STOBER Technical Support.

The following dimensions are required to provide the correct motor mounting plate:

1. D^6 Motor Shaft Diameter (If an adapter bushing is required it will be supplied with the motor plate.)
2. D^7 Pilot Diameter
3. D^8 Bolt Circle Diameter
4. D^9 Bolt Diameter
5. L^{11} Motor Shaft Length
6. L^{12} Pilot Length
7. L^{14} Square Flange (Optional — Motor plate will typically be made to match.)

Table No.1

Input Option	Shaft D^6 Max.	Motor Plate Thickness L^9 Min.	Input Option	Shaft D^6 Max.	Motor Plate Thickness L^9 Min.
KL1_MQ	16	15	MT30	38	25
KL2_MQ/MT10	19	21	MT40	48	33
MT20	24	24	MT50	60	43

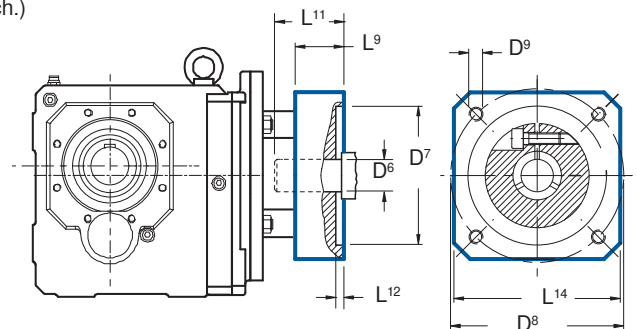

Refer to Page 302 for ServoFit Gearhead Selection Procedure.

“K” Series – Right Angle Helical/Bevel ServoFit® Modular System



Maintenance

With STOBER reducers very little maintenance is required under normal operating conditions. Units supplied without breathers are lubricated for life and maintenance free. Breathers are provided on standard units K513 through K1014, located as shown in Table 1.

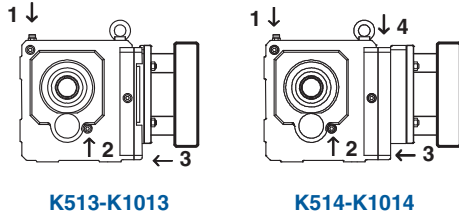

Table No. 1 Drain Plug and Vent Location

Mounting Position	1	2	2a	3	4
EL1	Vent			Drain	
EL2	Drain			Vent	
EL3		Vent			
EL4		Drain	Drain		
EL5 (K513/K1013)	Drain			Vent	
EL5 (K514/K1014)	Drain				Vent
EL6 (K513/K1013)	Vent			Drain	
EL6 (K513/K1014)	Vent				Drain

Position 2a is on the opposite side of 2.

STOBER recommends that the lubrication be changed in units supplied with breathers according to the following schedule:
 Normal Operating Conditions — after 5000 Hours
 Wet Operating Conditions — after 2000 Hours.

Direction of Rotation

2 Stage—K102 thru K402

3 Stage—K203 thru K403

3 Stage—K513 thru K1013

4 Stage—K514 thru K1014

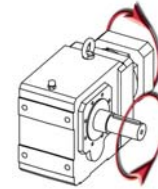
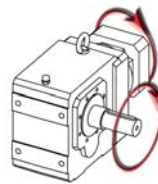
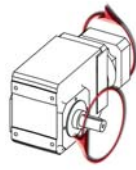
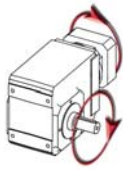

Overhung Load

Pulling forces or overhung load of pulleys, sheaves, sprockets, etc. on the reducer output shaft must not exceed the allowable limits shown in the above calculations. The overhung load shown is measured at the center of the shaft extension.

The following formula can be used to determine actual overhung load for a given drive.

METRIC

$$OHL = \frac{19,100 \times kW \times K}{D \times n}$$

where

- OHL = Newtons (N)
- kW = Transmitted Kilowatt
- D = Pitch Diameter (meters) of Sprocket, Gear, Sheave, Pulley, etc.
- n = Maximum Shaft RPM
- K = 1.00 Single Chain Drive
- 1.25 Timing Belt Drive
- 1.25 Spur, Helical Gear Drive
- 1.50 V-Belt Drive
- 2.50 Flat Belt Drive

IMPERIAL

$$OHL = \frac{126,000 \times HP \times K}{D \times RPM}$$

where

- OHL = Pounds (lbs.)
- HP = Horsepower
- D = Pitch Diameter (inches) of Sprocket, Gear, Sheave, Pulley, etc.
- n = Maximum Shaft RPM
- K = 1.00 Single Chain Drive
- 1.25 Timing Belt Drive
- 1.25 Spur, Helical Gear Drive
- 1.50 V-Belt Drive
- 2.50 Flat Belt Drive

No overhung load is encountered when an reducer is flange mounted and/or coupling connected to another unit. However, the shafts of all components must be accurately aligned and secured to prevent pre-loading of the bearings and premature bearing failure.



“K” Series – Right Angle Helical/Bevel ServoFit® Modular System Shaft Loads

Permissible Shaft Load and Tilting Moment

All formulas shown are based on METRIC values.

Upper case letters are permissible values. Lower case letters are for existing values.

The permissible load values given are valid with the load applied to the center of the output shaft (x₂).

The permissible load and tilting moment values are based on an output speed of 20 RPM. For higher speeds the following applies, where n₂ is the desired speed:

$$F_{2AX} = \frac{F_{2A}}{\sqrt[3]{\frac{n_2}{20}}} \quad F_{2RX} = \frac{F_{2R}}{\sqrt[3]{\frac{n_2}{20}}} \quad M_{2KX} = \frac{M_{2K}}{\sqrt[3]{\frac{n_2}{20}}}$$

The application input tilting moment should be determined by the following formula:

$$M_{2A} = \frac{2 \cdot F_{2A} \cdot y_2 + F_{2R} \cdot (x_2 + z_2)}{1000} \leq M_{2K}$$

- F_{2a} Axial Load at Output Shaft
- F_{2A} Permissible Axial Load
- F_{2r} Radial Load at Output Shaft
- F_{2R} Permissible Radial Load
- F_{2RB} ... Acceleration Permissible Radial Load
- M_{2K} ... Rated Tilting Torque
- M_{2k} Equivalent Tilting Load
- Z₂ Distance Factor

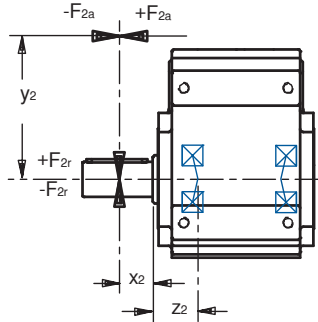

Table No. 2 “K” Series – Permissible Load and Tilting Moments

Unit No.	Solid Shaft Output – “V” Style ²⁾					Hollow Output – “A”, “S”, and “W” Style ¹⁾									
	z ₂ mm	z ₂ ins	F _{2A} N	F _{2A} lbs.	F _{2R} N	F _{2R} lbs.	M _{2K} Nm	M _{2K} in.lbs.	Unit No.	z ₂ mm	z ₂ ins	F _{2A} N	F _{2A} lbs.	M _{2K} Nm	M _{2K} in.lbs.
KL1_V	18.5	.728	250	56	1,250	281	43	381	KL1_A	18.5	.728	250	56	43	381
KL2_V	22	.866	560	126	2,800	630	118	1,044	KL2_A	22	.866	560	126	118	1,044
K1_V	40	1.57	1,900	427	5,000	1,125	360	3,186	K1_A	40	1.57	1,900	427	240	2,124
K2_V	42	1.65	2,100	472	6,000	1,350	430	3,805	K2_A	42	1.65	2,100	472	310	2,744
K3_V	45	1.77	2,400	540	7,000	1,575	525	4,646	K3_A	45	1.77	2,400	540	380	3,363
K4_V	52	2.05	3,500	787	11,200	2,520	1,050	9,292	K4_A	52	2.05	3,500	788	740	6,549
K5_V	72	2.83	3,500	787	13,450	3,026	1,580	13,983	K5_A	36	1.42	2,500	563	1,000	8,850
K6_V	72	2.83	4,000	900	16,000	3,600	1,960	17,346	K6_A	42	1.65	3,000	675	1,300	11,505
K7_V	85	3.35	5,500	1,237	22,000	4,950	3,200	28,320	K7_A	45	1.77	4,100	923	2,100	18,585
K8_V	60	2.36	7,250	1,631	29,000	6,525	3,800	33,630	K8_A	50	1.97	5,300	1,193	2,600	23,010
K9_V	87	3.43	16,500	3,712	65,000	14,625	11,200	89,385	K9_A	56	2.20	7,000	1,575	3,600	31,860
K10_V	84 ³⁾	3.31	25,000	5,625	80,000 ³⁾	18,000	15,200	134,520	K10_A	56	2.20	9,000	2,025	5,000	44,250

¹⁾ Values shown for “W” Style are for double bushings. For single bushings use value M_{2K} x 0.5 and F_{2A} x 0.5.

²⁾ For DOUBLE output shaft: F_{2R} x 0.7

³⁾ Solid Shaft unit with a Flange — z₂ value is 132mm/5.20”; F_{2R} value is 64,000N/14,400 lbs.

Permissible Motor Tilting Torque

The permissible tilting torque of the motor attached to the gear unit is a result of the static and dynamic load “F” from the motor weight, mass acceleration, and vibration multiplied by the distance from the center of gravity “l_s” of the motor.

$$M_{1k} = F \times l_s \leq M_{1K}$$

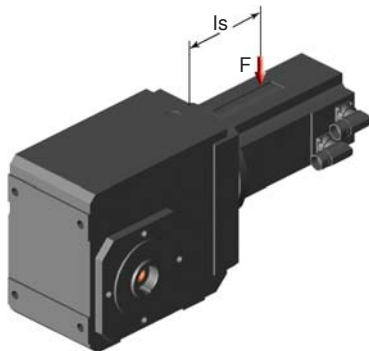

Table No. 1 M_{1K} Permissible Motor Tilting Torque

“K” Series Unit with MT	Nm	in.lbs.
MT10	25	221
MT20	60	531
MT30	125	1,106
MT40	250	2,212
MT50	600	5,310



"K" Series—Right Angle Helical/Bevel ServoFit® Modular System Selection Data



Part Number	Reducer Ratio i		Input RPM			Backlash arcmins $\Delta\phi$ ¹⁾	Input Inertia J ₁ kgcm ²	Torsional Stiffness per arcmin C ₂		Output Torque					
			Maximum							Nominal ²⁾		Acceleration		Peak ³⁾	
	Nom.		Exact		Continuous			Cyclic	M _{2N} ≤ 2000 RPM		M _{2B}		M _{2PEAK}		
	n _{1DBH}	n _{1DBV}	n _{1ZB}	in.lbs.	Nm			in.lbs.	Nm	in.lbs.	Nm	in.lbs.	Nm		
KL102 with MQ Motor Adapter										Noise Level ≤ 59 dB(A) ⁴⁾					
KL102_0040 MQ	4.000	4/1	3,500	3,500	5,000	25	0.38	9	1.0	133	15	192	22	257	29
KL102_0080 MQ	8.000	8/1	3,500	3,500	5,000	20	0.35	14	1.6	201	23	266	30	515	58
KL102_0160 MQ	16.00	16/1	4,000	4,000	6,000	20	0.29	16	1.8	221	25	266	30	531	60
KL102_0320 MQ	32.00	32/1	4,000	4,000	6,000	20	0.28	15	1.7	221	25	283	32	567	64
KL202 with MQ Motor Adapter										Noise Level ≤ 65 dB(A) ⁴⁾					
KL202_0040 MQ	4.000	4/1	3,500	3,500	5,000	20	0.89	16	1.8	285	32	412	47	516	58
KL202_0080 MQ	8.000	8/1	3,500	3,500	5,000	16	0.77	31	3.5	402	45	531	60	1,031	116
KL202_0160 MQ	16.00	16/1	4,000	4,000	6,000	16	0.54	35	3.9	443	50	531	60	1,063	120
KL202_0320 MQ	32.00	32/1	4,000	4,000	6,000	16	0.52	28	3.2	443	50	576	65	1,152	130
K102 with MT TriAdapt® Motor Adapter Continued Next Page										Noise Level ≤ 53 dB(A) ⁴⁾					
K102_0040 MT10	4.000	4/1	3,300	2,800	4,500	12/6	1.4	25	2.8	368	42	368	42	460	52
K102_0040 MT20	4.000	4/1	3,300	2,800	4,500	12/6	2.0	25	2.9	512	58	693	78	866	98
K102_0056 MT10	5.568	1520/273	3,300	2,800	4,500	12/6	1.3	38	4.3	512	58	512	58	640	72
K102_0056 MT20	5.568	1520/273	3,300	2,800	4,500	12/6	1.9	39	4.5	572	65	965	109	1,206	136
K102_0060 MT10	6.000	6/1	3,300	2,800	4,500	12/6	1.1	30	3.4	523	59	523	59	654	74
K102_0060 MT20	6.000	6/1	3,300	2,800	4,500	12/6	1.7	30	3.4	587	66	985	111	1,231	139
K102_0066 MT10	6.644	299/45	3,600	3,300	5,000	12/6	1.0	31	3.5	570	64	570	64	712	80
K102_0066 MT20	6.644	299/45	3,500	3,300	5,000	12/6	1.6	31	3.5	607	69	1,025	116	1,340	151
K102_0083 MT10	8.309	1911/230	3,600	3,300	5,000	12/6	0.9	33	3.7	654	74	684	77	855	97
K102_0083 MT20	8.309	1911/230	3,500	3,300	5,000	12/6	1.5	33	3.7	654	74	1,104	125	1,611	182
K102_0092 MT10	9.249	1748/189	3,600	3,300	5,000	12/6	0.9	46	5.2	678	76	793	90	991	112
K102_0092 MT20	9.249	1748/189	3,500	3,300	5,000	12/6	1.5	46	5.2	678	76	1,145	129	1,866	211
K102_0100 MT10	10.14	507/50	4,000	3,800	5,500	12/6	0.8	34	3.8	699	79	806	91	1,008	114
K102_0100 MT20	10.14	507/50	3,500	3,500	5,000	12/6	1.4	34	3.8	699	79	1,107	125	1,898	214
K102_0115 MT10	11.57	266/23	3,600	3,300	5,000	12/6	0.8	48	5.4	730	82	952	108	1,190	134
K102_0115 MT20	11.57	266/23	3,500	3,300	5,000	12/6	1.4	48	5.4	730	82	1,196	135	2,126	240
K102_0125 MT10	12.62	429/34	4,000	3,800	5,500	12/6	0.7	34	3.9	751	85	963	109	1,204	136
K102_0125 MT20	12.62	429/34	3,500	3,500	5,000	12/6	1.3	35	3.9	751	85	1,107	125	1,949	220
K102_0140 MT10	14.11	494/35	4,000	3,800	5,500	12/6	0.8	49	5.5	780	88	1,122	127	1,403	158
K102_0140 MT20	14.11	494/35	3,500	3,500	5,000	12/6	1.4	49	5.6	780	88	1,196	135	2,126	240
K102_0165 MT10	16.71	117/7	4,000	4,000	6,000	12/6	0.7	35	4.0	825	93	1,107	125	1,520	172
K102_0165 MT20	16.71	117/7	3,500	3,500	5,000	12/6	1.3	35	4.0	825	93	1,107	125	1,520	172
K102_0175 MT10	17.56	2090/119	4,000	3,800	5,500	12/6	0.7	50	5.6	839	95	1,196	135	1,676	189
K102_0175 MT20	17.56	2090/119	3,500	3,500	5,000	12/6	1.3	50	5.6	839	95	1,196	135	2,126	240
K102_0200 MT10	20.15	403/20	4,000	4,000	6,000	12/6	0.7	35	4.0	878	99	1,107	125	1,763	199
K102_0200 MT20	20.15	403/20	3,500	3,500	5,000	12/6	1.3	35	4.0	878	99	1,107	125	1,763	199
K102_0230 MT10	23.27	1140/49	4,000	4,000	6,000	12/6	0.7	51	5.7	921	104	1,196	135	2,115	239
K102_0230 MT20	23.27	1140/49	3,500	3,500	5,000	12/6	1.3	51	5.7	921	104	1,196	135	2,115	239
K102_0250 MT10	25.22	1261/50	4,000	4,000	6,000	12/6	0.6	36	4.0	851	96	1,021	115	1,701	192
K102_0250 MT20	25.22	1261/50	3,500	3,500	5,000	12/6	1.2	36	4.0	851	96	1,021	115	1,701	192
K102_0280 MT10	28.05	589/21	4,000	4,000	6,000	12/6	0.7	51	5.7	981	111	1,196	135	2,126	240
K102_0280 MT20	28.05	589/21	3,500	3,500	5,000	12/6	1.3	51	5.8	981	111	1,196	135	2,126	240
K102_0340 MT10	33.71	4719/140	4,000	4,000	6,000	12/6	0.6	36	4.0	647	73	776	88	1,293	146
K102_0350 MT10	35.11	3686/105	4,000	4,000	6,000	12/6	0.6	51	5.8	1,057	119	1,196	135	2,126	240
K102_0350 MT20	35.11	3686/105	3,500	3,500	5,000	12/6	1.2	51	5.8	1,057	119	1,196	135	2,126	240
K102_0400 MT10	40.30	403/10	4,000	4,000	6,000	12/6	0.6	36	4.1	544	61	653	74	846	96

- ¹⁾ Backlash shown "STANDARD/REDUCED".
- ²⁾ Maximum torque for continuous input RPM - horizontal output position.
- ³⁾ Maximum momentary torque for emergency stops or heavy shock load. Admissible stops per life of reducer = 1,000 stops maximum.
- ⁴⁾ dB(A) Measured at 1 meter distance with 3000 RPM input

Maximum Motor Shaft

Adapter	Diameter	Adapter	Diameter	Adapter	Diameter
KL1_MQ	16	MT10	19	MT40	48
KL2_MQ	19	MT20	24	MT50	60
		MT30	38		



"K" Series—Right Angle Helical/Bevel ServoFit® Modular System Selection Data



Part Number	Reducer Ratio i		Input RPM			Backlash arcmin $\Delta\phi$ ¹⁾	Input Inertia J ₁ kgcm ²	Torsional Stiffness per arcmin C ₂		Output Torque					
			Maximum							Nominal ²⁾		Acceleration		Peak ³⁾	
	Nom.	Exact	n _{1DBH}	n _{1DBV}	n _{1ZB}			M _{2N} ≤ 2000 RPM		M _{2B}		M _{2PEAK}			
								in.lbs.	Nm	in.lbs.	Nm	in.lbs.	Nm		
K102 with MT TriAdapt® Motor Adapter Continued										Noise Level ≤ 53 dB(A) ⁴⁾					
K102_0470 MT10	46.92	2299/49	4,000	4,000	6,000	12/6	0.6	51	5.8	900	102	1,080	122	1,800	203
K102_0500 MT10	50.31	5031/100	4,000	4,000	6,000	12/6	0.6	36	4.1	442	50	531	60	885	100
K102_0560 MT10	56.10	1178/21	4,000	4,000	6,000	12/6	0.6	51	5.8	758	86	909	103	1,178	133
K102_0700 MT10	70.03	2451/35	4,000	4,000	6,000	12/6	0.6	51	5.8	616	70	739	83	1,232	139
K202 with MT TriAdapt® Motor Adapter Continued Next Page										Noise Level ≤ 53 dB(A) ⁴⁾					
K202_0040 MT10	4.000	4/1	3,000	2,600	4,000	10/5	3.1	33	3.8	393	44	393	44	491	55
K202_0040 MT20	4.000	4/1	3,000	2,600	4,000	10/5	3.7	35	3.9	915	103	1,512	171	2,170	245
K202_0040 MT30	4.000	4/1	3,000	2,600	4,000	10/5	8.5	41	4.7	915	103	1,546	174	2,170	245
K202_0044 MT10	4.364	48/11	3,000	2,600	4,000	10/5	2.7	36	4.1	421	48	421	48	526	59
K202_0044 MT20	4.364	48/11	3,000	2,600	4,000	10/5	3.3	37	4.2	942	106	1,591	180	2,327	263
K202_0044 MT30	4.364	48/11	3,000	2,600	4,000	10/5	8.1	43	4.9	942	106	1,591	180	2,327	263
K202_0052 MT20	5.177	2107/407	3,000	2,600	4,000	10/5	2.9	42	4.7	997	113	1,684	190	2,724	308
K202_0052 MT30	5.177	2107/407	3,000	2,600	4,000	10/5	7.7	47	5.3	997	113	1,684	190	2,724	308
K202_0060 MT10	6.000	6/1	3,000	2,600	4,000	10/5	2.3	51	5.8	579	65	579	65	724	82
K202_0060 MT20	6.000	6/1	3,000	2,600	4,000	10/5	2.9	53	5.9	1,047	118	1,769	200	3,199	361
K202_0060 MT30	6.000	6/1	3,000	2,600	4,000	10/5	7.7	59	6.6	1,047	118	1,769	200	3,199	361
K202_0067 MT10	6.683	2279/341	3,500	3,100	4,500	10/5	1.7	46	5.2	609	69	609	69	761	86
K202_0067 MT20	6.683	2279/341	3,500	3,100	4,500	10/5	2.3	47	5.3	1,086	123	1,834	207	3,364	380
K202_0067 MT30	6.683	2279/341	3,500	3,100	4,000	10/5	7.1	51	5.8	1,086	123	1,834	207	3,364	380
K202_0071 MT20	7.118	2107/296	3,000	2,600	4,000	10/5	2.6	57	6.4	1,109	125	1,873	211	3,543	400
K202_0071 MT30	7.118	2107/296	3,000	2,600	4,000	10/5	7.4	62	7.0	1,109	125	1,873	211	3,543	400
K202_0084 MT10	8.397	2494/297	3,500	3,100	4,500	10/5	1.4	50	5.7	739	83	739	83	924	104
K202_0084 MT20	8.397	2494/297	3,500	3,100	4,500	10/5	2.0	51	5.7	1,171	132	1,949	220	3,543	400
K202_0084 MT30	8.397	2494/297	3,500	3,100	4,000	10/5	6.8	54	6.1	1,171	132	1,949	220	3,543	400
K202_0092 MT10	9.190	2279/248	3,500	3,100	4,500	10/5	1.5	61	6.9	837	95	837	95	1,046	118
K202_0092 MT20	9.190	2279/248	3,500	3,100	4,500	10/5	2.1	62	7.0	1,207	136	1,949	220	3,543	400
K202_0092 MT30	9.190	2279/248	3,500	3,100	4,000	10/5	6.9	66	7.4	1,207	136	1,949	220	3,543	400
K202_0100 MT10	10.07	2881/286	3,900	3,500	5,000	10/5	1.2	52	5.9	855	97	855	97	1,069	121
K202_0100 MT20	10.07	2881/286	3,500	3,500	5,000	10/5	1.8	53	6.0	1,245	141	1,949	220	3,543	400
K202_0100 MT30	10.07	2881/286	3,500	3,500	4,000	10/5	6.6	55	6.2	1,245	141	1,949	220	3,543	400
K202_0115 MT10	11.55	1247/108	3,500	3,100	4,500	10/5	1.3	65	7.3	1,016	115	1,016	115	1,270	143
K202_0115 MT20	11.55	1247/108	3,500	3,100	4,500	10/5	1.9	66	7.4	1,303	147	1,949	220	3,543	400
K202_0115 MT30	11.55	1247/108	3,500	3,100	4,000	10/5	6.7	68	7.7	1,303	147	1,949	220	3,543	400
K202_0125 MT10	12.71	559/44	3,900	3,500	5,000	10/5	1.0	55	6.2	1,037	117	1,037	117	1,297	146
K202_0125 MT20	12.71	559/44	3,500	3,500	5,000	10/5	1.6	55	6.2	1,345	152	1,949	220	3,543	400
K202_0125 MT30	12.71	559/44	3,500	3,500	4,000	10/5	6.4	56	6.4	1,345	152	1,949	220	3,543	400
K202_0140 MT10	13.85	2881/208	3,900	3,500	5,000	10/5	1.1	67	7.6	1,176	133	1,176	133	1,470	166
K202_0140 MT20	13.85	2881/208	3,500	3,500	5,000	10/5	1.7	67	7.6	1,384	156	1,949	220	3,543	400
K202_0140 MT30	13.85	2881/208	3,500	3,500	4,000	10/5	6.5	69	7.8	1,384	156	1,949	220	3,543	400
K202_0170 MT10	16.86	2967/176	4,000	3,900	5,500	10/5	0.9	56	6.4	1,302	147	1,302	147	1,627	184
K202_0170 MT20	16.86	2967/176	3,500	3,500	5,000	10/5	1.5	57	6.4	1,478	167	1,949	220	3,543	400
K202_0170 MT30	16.86	2967/176	3,500	3,500	4,000	10/5	6.3	57	6.5	1,478	167	1,949	220	3,543	400
K202_0175 MT10	17.47	559/32	3,900	3,500	5,000	10/5	1.0	69	7.8	1,426	161	1,426	161	1,783	201
K202_0175 MT20	17.47	559/32	3,500	3,500	5,000	10/5	1.6	69	7.8	1,495	169	1,949	220	3,543	400
K202_0175 MT30	17.47	559/32	3,500	3,500	4,000	10/5	6.4	70	7.9	1,495	169	1,949	220	3,543	400
K202_0200 MT10	20.33	1118/55	4,000	3,900	5,500	10/5	0.8	57	6.4	1,504	170	1,504	170	1,880	212
K202_0200 MT20	20.33	1118/55	3,500	3,500	5,000	10/5	1.4	57	6.5	1,573	178	1,949	220	3,541	400
K202_0200 MT30	20.33	1118/55	3,500	3,500	4,000	10/5	6.2	58	6.5	1,573	178	1,949	220	3,541	400

Index of Symbols: **MT** — Motor adapter with TriAdapt® coupling; **MQ** — Square Motor adapter

See Page 238 for Options and Part Number Configuration.



"K" Series—Right Angle Helical/Bevel ServoFit® Modular System Selection Data



Part Number	Reducer Ratio i		Input RPM			Backlash arcmins $\Delta\phi$ ¹⁾	Input Inertia J ₁ kgcm ²	Torsional Stiffness per arcmin C ₂		Output Torque					
			Maximum							Nominal ²⁾		Acceleration		Peak ³⁾	
	Continuous		Cyclic	M _{2N} ≤ 2000 RPM				M _{2B}		M _{2PEAK}					
	Nom.	Exact	n _{1DBH}	n _{1DBV}	n _{1ZB}			in.lbs.	Nm	in.lbs.	Nm	in.lbs.	Nm		

K202 with MT TriAdapt® Motor Adapter *Continued*

Noise Level ≤ 53 dB(A) ⁴⁾

K202_0230 MT10	23.18	2967/128	4,000	3,900	5,500	10/5	0.8	70	7.9	1,643	186	1,790	202	2,237	253
K202_0230 MT20	23.18	2967/128	3,500	3,500	5,000	10/5	1.4	70	7.9	1,643	186	1,949	220	3,543	400
K202_0230 MT30	23.18	2967/128	3,500	3,500	4,000	10/5	6.2	71	8.0	1,643	186	1,949	220	3,543	400
K202_0250 MT10	25.13	1935/77	4,000	3,900	5,500	10/5	0.7	58	6.5	1,688	191	1,775	200	2,219	250
K202_0250 MT20	25.13	1935/77	3,500	3,500	5,000	10/5	1.3	58	6.5	1,688	191	1,949	220	3,543	400
K202_0250 MT30	25.13	1935/77	3,500	3,500	4,000	10/5	6.1	58	6.6	1,688	191	1,949	220	3,543	400
K202_0280 MT10	27.95	559/20	4,000	3,900	5,500	10/5	0.8	71	8.0	1,749	197	1,949	220	2,586	292
K202_0280 MT20	27.95	559/20	3,500	3,500	5,000	10/5	1.4	71	8.0	1,749	197	1,949	220	3,543	400
K202_0280 MT30	27.95	559/20	3,500	3,500	4,000	10/5	6.2	71	8.1	1,749	197	1,949	220	3,543	400
K202_0340 MT10	33.62	1849/55	4,000	3,900	5,500	10/5	0.7	58	6.6	1,364	154	1,637	185	2,729	308
K202_0340 MT20	33.62	1849/55	3,500	3,500	5,000	10/5	1.3	58	6.6	1,364	154	1,637	185	2,729	308
K202_0350 MT10	34.55	1935/56	4,000	3,900	5,500	10/5	0.7	71	8.0	1,772	200	1,949	220	3,051	344
K202_0350 MT20	34.55	1935/56	3,500	3,500	5,000	10/5	1.3	71	8.1	1,772	200	1,949	220	3,543	400
K202_0350 MT30	34.55	1935/56	3,500	3,500	4,000	10/5	6.1	72	8.1	1,772	200	1,949	220	3,543	400
K202_0400 MT10	40.39	1333/33	4,000	3,900	5,500	10/5	0.7	58	6.6	1,023	116	1,228	139	1,690	191
K202_0460 MT10	46.23	1849/40	4,000	3,900	5,500	10/5	0.7	72	8.1	1,772	200	1,949	220	3,543	400
K202_0460 MT20	46.23	1849/40	3,500	3,500	5,000	10/5	1.3	72	8.1	1,772	200	1,949	220	3,543	400
K202_0500 MT10	50.49	6665/132	4,000	3,900	5,500	10/5	0.6	58	6.6	853	96	1,023	116	1,705	193
K202_0560 MT10	55.54	1333/24	4,000	3,900	5,500	10/5	0.7	72	8.1	1,407	159	1,688	191	2,323	262
K202_0690 MT10	69.43	6665/96	4,000	3,900	5,500	10/5	0.6	72	8.1	1,172	132	1,407	159	2,345	265

K203 with MT TriAdapt® Motor Adapter

Noise Level ≤ 53 dB(A) ⁴⁾

K203_0390 MT10	39.45	135407/3432	4,000	3,900	5,500	10/6	0.7	58	6.6	1,431	162	1,431	162	1,788	202
K203_0450 MT10	45.22	58609/1296	4,000	3,900	5,500	10/6	0.7	72	8.1	1,640	185	1,640	185	2,050	231
K203_0500 MT10	49.76	26273/528	4,000	3,900	5,500	10/6	0.7	58	6.6	1,772	200	1,804	204	2,256	255
K203_0540 MT10	54.25	135407/2496	4,000	3,900	5,500	10/6	0.7	72	8.1	1,772	200	1,949	220	2,459	278
K203_0660 MT10	66.03	46483/704	4,000	3,900	5,500	10/6	0.7	59	6.6	1,772	200	1,949	220	2,993	338
K203_0680 MT10	68.42	26273/384	4,000	3,900	5,500	10/6	0.7	72	8.1	1,772	200	1,949	220	3,101	350
K203_0800 MT10	79.62	26273/330	4,000	3,900	5,500	10/6	0.7	59	6.6	1,772	200	1,949	220	3,540	400
K203_0910 MT10	90.79	46483/512	4,000	3,900	5,500	10/6	0.7	72	8.1	1,772	200	1,949	220	3,543	400
K203_1090 MT10	109.5	26273/240	4,000	3,900	5,500	10/6	0.7	72	8.1	1,772	200	1,949	220	3,543	400
K203_1350 MT10	135.3	30315/224	4,000	3,900	5,500	10/6	0.7	72	8.1	1,772	200	1,949	220	3,543	400
K203_1810 MT10	181.0	86903/480	4,000	3,900	5,500	10/6	0.7	72	8.1	1,772	200	1,949	220	3,543	400
K203_2180 MT10	217.5	62651/288	4,000	3,900	5,500	10/6	0.6	72	8.1	1,407	159	1,688	191	2,323	262
K203_2720 MT10	271.9	313255/1152	4,000	3,900	5,500	10/6	0.6	72	8.1	1,172	132	1,407	159	2,345	265

K302 with MT TriAdapt® Motor Adapter *Continued Next Page*

Noise Level ≤ 53 dB(A) ⁴⁾

K302_0040 MT20	4.000	4/1	2,700	2,300	3,800	10/4	6.4	40	4.5	1,375	155	1,512	171	2,238	253
K302_0040 MT30	4.000	4/1	2,700	2,300	3,800	10/4	11.2	49	5.5	1,602	181	2,707	306	5,772	652
K302_0044 MT20	4.364	48/11	2,700	2,300	3,800	10/4	5.7	43	4.9	1,500	169	1,650	186	2,421	273
K302_0044 MT30	4.364	48/11	2,700	2,300	3,800	10/4	10.5	52	5.8	1,650	186	2,787	315	6,201	700
K302_0054 MT20	5.375	43/8	2,700	2,300	3,800	10/4	4.5	51	5.7	1,768	200	2,032	229	2,884	326
K302_0054 MT30	5.375	43/8	2,700	2,300	3,800	10/4	9.3	58	6.5	1,768	200	2,307	260	2,884	326
K302_0060 MT20	6.000	6/1	2,700	2,300	3,800	10/4	4.8	59	6.7	1,834	207	2,268	256	3,328	376
K302_0060 MT30	6.000	6/1	2,700	2,300	3,800	10/4	9.6	67	7.6	1,834	207	3,099	350	6,201	700
K302_0067 MT20	6.740	2150/319	3,200	2,800	4,200	10/4	3.5	57	6.5	1,907	215	2,548	288	3,515	397
K302_0067 MT30	6.740	2150/319	3,200	2,800	4,000	10/4	8.3	63	7.1	1,907	215	2,812	317	3,515	397

Maximum Motor Shaft

Adapter	Diameter	Adapter	Diameter	Adapter	Diameter
KL1_MQ	16	MT10	19	MT40	48
KL2_MQ	19	MT20	24	MT50	60
		MT30	38		

¹⁾ Backlash shown "STANDARD/REDUCED".

²⁾ Maximum torque for continuous input RPM - horizontal output position.

³⁾ Maximum momentary torque for emergency stops or heavy shock load. Admissible stops per life of reducer = 1,000 stops maximum.

⁴⁾ dB(A) Measured at 1 meter distance with 3000 RPM input



"K" Series—Right Angle Helical/Bevel ServoFit® Modular System Selection Data



Part Number	Reducer Ratio i		Input RPM			Backlash arcmins $\Delta\phi$ ¹⁾	Input Inertia J ₁ kgcm ²	Torsional Stiffness per arcmin C ₂		Output Torque					
			Maximum							Nominal ²⁾		Acceleration		Peak ³⁾	
	Nom.	Exact	n _{1DBH}	n _{1DBV}	n _{1ZB}			M _{2N ≤ 2000 RPM}		M _{2B}		M _{2PEAK}			
								Continuous	Cyclic	in.lbs.	Nm	in.lbs.	Nm	in.lbs.	Nm
K302 with MT TriAdapt® Motor Adapter <i>Continued</i>										Noise Level ≤ 53 dB(A) ⁴⁾					
K302_0074 MT20	7.391	473/64	2,700	2,300	3,800	10/4	3.9	66	7.5	1,966	222	2,794	315	3,965	448
K302_0074 MT30	7.391	473/64	2,700	2,300	3,800	10/4	8.7	73	8.2	1,966	222	3,172	358	3,965	448
K302_0084 MT20	8.444	2322/275	3,200	2,800	4,200	10/4	2.8	63	7.1	2,056	232	3,192	360	4,244	479
K302_0084 MT30	8.444	2322/275	3,200	2,800	4,000	10/4	7.6	67	7.5	2,056	232	3,395	383	4,244	479
K302_0093 MT20	9.267	1075/116	3,200	2,800	4,200	10/4	3.2	72	8.2	2,120	239	3,410	385	4,833	546
K302_0093 MT30	9.267	1075/116	3,200	2,800	4,000	10/4	8.0	77	8.7	2,120	239	3,410	385	4,833	546
K302_0100 MT20	10.14	3010/297	3,500	3,100	5,000	10/4	2.4	66	7.4	2,185	247	3,410	385	4,911	554
K302_0100 MT30	10.14	3010/297	3,500	3,100	4,000	10/4	7.2	69	7.8	2,185	247	3,410	385	4,911	554
K302_0115 MT20	11.61	1161/100	3,200	2,800	4,200	10/4	2.6	77	8.6	2,286	258	3,410	385	5,835	659
K302_0115 MT30	11.61	1161/100	3,200	2,800	4,000	10/4	7.4	80	9.0	2,286	258	3,410	385	5,835	659
K302_0125 MT10	12.58	3182/253	3,500	3,100	5,000	10/4	1.5	68	7.7	1,059	120	1,059	120	1,324	150
K302_0125 MT20	12.58	3182/253	3,500	3,100	5,000	10/4	2.1	69	7.8	2,348	265	3,410	385	5,854	661
K302_0125 MT30	12.58	3182/253	3,500	3,100	4,000	10/4	6.9	71	8.0	2,348	265	3,410	385	5,854	661
K302_0140 MT20	13.94	1505/108	3,500	3,100	5,000	10/4	2.3	79	8.9	2,429	274	3,410	385	6,201	700
K302_0140 MT30	13.94	1505/108	3,500	3,100	4,000	10/4	7.1	81	9.2	2,429	274	3,410	385	6,201	700
K302_0170 MT10	16.94	559/33	3,800	3,500	5,000	10/4	1.1	71	8.0	1,342	152	1,342	152	1,678	189
K302_0170 MT20	16.94	559/33	3,500	3,500	5,000	10/4	1.7	71	8.1	2,592	293	3,410	385	6,201	700
K302_0170 MT30	16.94	559/33	3,500	3,500	4,000	10/4	6.5	73	8.2	2,592	293	3,410	385	6,201	700
K302_0175 MT10	17.29	1591/92	3,500	3,100	5,000	10/4	1.4	81	9.1	1,457	164	1,457	164	1,821	206
K302_0175 MT20	17.29	1591/92	3,500	3,100	5,000	10/4	2.0	81	9.2	2,610	295	3,410	385	6,201	700
K302_0175 MT30	17.29	1591/92	3,500	3,100	4,000	10/4	6.8	83	9.4	2,610	295	3,410	385	6,201	700
K302_0200 MT10	20.28	3569/176	3,800	3,500	5,000	10/4	1.0	72	8.1	1,555	176	1,555	176	1,943	219
K302_0200 MT20	20.28	3569/176	3,500	3,500	5,000	10/4	1.6	72	8.2	2,753	311	3,410	385	6,201	700
K302_0200 MT30	20.28	3569/176	3,500	3,500	4,000	10/4	6.4	73	8.3	2,753	311	3,410	385	6,201	700
K302_0230 MT10	23.29	559/24	3,800	3,500	5,000	10/4	1.1	83	9.4	1,845	208	1,845	208	2,307	260
K302_0230 MT20	23.29	559/24	3,500	3,500	5,000	10/4	1.7	83	9.4	2,883	325	3,410	385	6,201	700
K302_0230 MT30	23.29	559/24	3,500	3,500	4,000	10/4	6.5	84	9.5	2,883	325	3,410	385	6,201	700
K302_0250 MT10	25.26	3612/143	3,800	3,500	5,000	10/4	0.9	73	8.2	1,839	208	1,839	208	2,298	259
K302_0250 MT20	25.26	3612/143	3,500	3,500	5,000	10/4	1.5	73	8.3	2,962	334	3,410	385	4,328	489
K302_0250 MT30	25.26	3612/143	3,500	3,500	4,000	10/4	6.3	74	8.3	2,962	334	3,410	385	4,328	489
K302_0280 MT10	27.88	3569/128	3,800	3,500	5,000	10/4	1.0	84	9.4	2,138	241	2,138	241	2,672	302
K302_0280 MT20	27.88	3569/128	3,500	3,500	5,000	10/4	1.6	84	9.5	3,061	346	3,410	385	6,201	700
K302_0280 MT30	27.88	3569/128	3,500	3,500	4,000	10/4	6.4	85	9.5	3,061	346	3,410	385	6,201	700
K302_0340 MT10	33.62	1849/55	3,800	3,500	5,000	10/4	0.8	74	8.3	2,217	250	2,299	260	2,874	324
K302_0340 MT20	33.62	1849/55	3,500	3,500	5,000	10/4	1.4	74	8.3	2,217	250	2,660	300	4,434	501
K302_0340 MT30	33.62	1849/55	3,500	3,500	4,000	10/4	6.2	74	8.4	2,217	250	2,660	300	4,434	501
K302_0350 MT10	34.73	903/26	3,800	3,500	5,000	10/4	0.9	84	9.5	2,528	285	2,528	285	3,160	357
K302_0350 MT20	34.73	903/26	3,500	3,500	5,000	10/4	1.5	84	9.5	3,100	350	3,410	385	5,951	672
K302_0350 MT30	34.73	903/26	3,500	3,500	4,000	10/4	6.3	85	9.6	3,100	350	3,410	385	5,951	672
K302_0410 MT10	40.51	4902/121	3,800	3,500	5,000	10/4	0.7	74	8.4	1,705	193	2,046	231	3,334	376
K302_0410 MT20	40.51	4902/121	3,500	3,500	5,000	10/4	1.3	74	8.4	1,705	193	2,046	231	3,334	376
K302_0460 MT10	46.23	1849/40	3,800	3,500	5,000	10/4	0.8	85	9.6	3,048	344	3,162	357	3,952	446
K302_0460 MT20	46.23	1849/40	3,500	3,500	5,000	10/4	1.4	85	9.6	3,048	344	3,410	385	6,097	688
K302_0460 MT30	46.23	1849/40	3,500	3,500	4,000	10/4	6.2	85	9.6	3,048	344	3,410	385	6,097	688
K302_0500 MT10	50.49	6665/132	3,800	3,500	5,000	10/4	0.7	74	8.4	1,364	154	1,637	185	2,072	234
K302_0560 MT10	55.71	2451/44	3,800	3,500	5,000	10/4	0.7	85	9.6	2,345	265	2,814	318	4,584	517
K302_0560 MT20	55.71	2451/44	3,500	3,500	5,000	10/4	1.3	85	9.6	2,345	265	2,814	318	4,584	517
K302_0690 MT10	69.43	6665/96	3,800	3,500	5,000	10/4	0.7	85	9.6	1,876	212	2,251	254	2,849	322

Index of Symbols: **MT** — Motor adapter with TriAdapt® coupling; **MQ** — Square Motor adapter

See Page 238 for Options and Part Number Configuration.





"K" Series—Right Angle Helical/Bevel ServoFit® Modular System Selection Data



Part Number	Reducer Ratio i		Input RPM			Backlash arcmins $\Delta\phi$ ¹⁾	Input Inertia J ₁ kgcm ²	Torsional Stiffness per arcmin C ₂		Output Torque					
			Maximum							Nominal ²⁾		Acceleration		Peak ³⁾	
	Nom.		Exact		M _{2N} ≤ 2000 RPM			M _{2B}		M _{2PEAK}					
	n_{1DBH}	n_{1DBV}	n_{1ZB}	in.lbs.	Nm			in.lbs.	Nm	in.lbs.	Nm	in.lbs.	Nm		

K303 with MT TriAdapt® Motor Adapter

Noise Level ≤ 53 dB(A) ⁴⁾

K303_0330 MT20	32.65	44892/1375	3,500	3,500	5,000	10/5	1.5	74	8.3	3,100	350	3,394	383	4,243	479
K303_0360 MT20	35.83	215/6	3,500	3,500	5,000	10/5	1.5	85	9.5	3,100	350	3,410	385	4,833	546
K303_0390 MT20	39.19	34916/891	3,500	3,500	5,000	10/5	1.4	74	8.4	3,100	350	3,410	385	4,910	554
K303_0450 MT20	44.89	11223/250	3,500	3,500	5,000	10/5	1.4	85	9.6	3,100	350	3,410	385	5,834	659
K303_0490 MT10	49.26	74777/1518	3,800	3,500	5,000	10/5	0.7	74	8.4	1,786	202	1,786	202	2,233	252
K303_0490 MT20	48.63	184556/3795	3,500	3,500	5,000	10/5	1.4	74	8.4	3,100	350	3,410	385	5,854	661
K303_0540 MT20	53.88	8729/162	3,500	3,500	5,000	10/5	1.4	85	9.6	3,100	350	3,410	385	6,201	700
K303_0550 MT10	54.58	70735/1296	3,800	3,500	5,000	10/5	0.7	85	9.6	1,979	223	1,979	223	2,474	279
K303_0650 MT20	65.50	32422/495	3,500	3,500	5,000	10/5	1.4	75	8.4	3,100	350	3,410	385	6,201	700
K303_0660 MT10	66.35	26273/396	3,800	3,500	5,000	10/5	0.7	75	8.4	2,406	272	2,406	272	3,007	340
K303_0670 MT20	66.87	46139/690	3,500	3,500	5,000	10/5	1.4	85	9.6	3,100	350	3,410	385	6,201	700
K303_0680 MT10	67.73	74777/1104	3,800	3,500	5,000	10/5	0.7	85	9.6	2,456	277	2,456	277	3,070	347
K303_0780 MT20	78.41	103501/1320	3,500	3,500	5,000	10/5	1.4	75	8.4	3,100	350	3,410	385	6,201	700
K303_0790 MT10	79.42	167743/2112	3,800	3,500	5,000	10/5	0.7	75	8.4	2,832	320	2,880	325	3,600	406
K303_0900 MT20	90.06	16211/180	3,500	3,500	5,000	10/5	1.4	85	9.6	3,100	350	3,410	385	6,201	700
K303_0910 MT10	91.23	26273/288	3,800	3,500	5,000	10/5	0.7	85	9.6	3,100	350	3,308	373	4,135	467
K303_1080 MT20	107.8	103501/960	3,500	3,500	5,000	10/5	1.4	85	9.6	3,100	350	3,410	385	6,201	700
K303_1090 MT10	109.2	167743/1536	3,800	3,500	5,000	10/5	0.7	85	9.6	3,100	350	3,410	385	4,950	559
K303_1340 MT20	134.3	8729/65	3,500	3,500	5,000	10/5	1.4	85	9.7	3,100	350	3,410	385	5,950	672
K303_1360 MT10	136.0	14147/104	3,800	3,500	5,000	10/5	0.7	85	9.7	3,100	350	3,410	385	5,950	672
K303_1790 MT20	178.7	53621/300	3,500	3,500	5,000	10/5	1.4	86	9.7	3,048	344	3,410	385	6,097	688
K303_1810 MT10	181.0	86903/480	3,800	3,500	5,000	10/5	0.7	86	9.7	3,048	344	3,410	385	6,097	688
K303_2180 MT10	218.2	38399/176	3,800	3,500	5,000	10/5	0.7	86	9.7	2,345	265	2,814	318	4,583	517
K303_2720 MT10	271.9	313255/1152	3,800	3,500	5,000	10/5	0.7	86	9.7	1,876	212	2,251	254	2,849	322

K402 with MT TriAdapt® Motor Adapter Continued Next Page

Noise Level ≤ 51 dB(A) ⁴⁾

K402_0040 MT20	4.000	4/1	2,600	2,200	3,500	10/4	11.4	55	6.2	1,375	155	1,512	171	2,311	261
K402_0040 MT30	4.000	4/1	2,600	2,200	3,500	10/4	16.2	72	8.2	2,405	271	3,592	405	5,960	673
K402_0040 MT40	4.000	4/1	2,600	2,200	3,500	10/4	20.2	99	11.2	2,405	271	4,062	459	5,960	673
K402_0044 MT20	4.364	48/11	2,600	2,200	3,500	10/4	10.1	61	6.9	1,500	169	1,650	186	2,503	283
K402_0044 MT30	4.364	48/11	2,600	2,200	3,500	10/4	14.9	79	8.9	2,475	279	3,918	442	6,456	729
K402_0044 MT40	4.364	48/11	2,600	2,200	3,500	10/4	18.9	105	11.8	2,475	279	4,182	472	6,456	729
K402_0054 MT20	5.422	1849/341	2,600	2,200	3,500	10/4	7.5	77	8.7	1,863	210	2,050	231	3,021	341
K402_0054 MT30	5.422	1849/341	2,600	2,200	3,500	10/4	12.3	95	10.7	2,661	300	4,496	508	7,791	880
K402_0054 MT40	5.422	1849/341	2,600	2,200	3,500	10/4	16.3	117	13.2	2,661	300	4,496	508	7,791	880
K402_0060 MT20	6.000	6/1	2,600	2,200	3,500	10/4	8.4	92	10.4	2,062	233	2,268	256	3,442	389
K402_0060 MT30	6.000	6/1	2,600	2,200	3,500	10/4	13.2	113	12.8	2,752	311	4,650	525	8,877	1,002
K402_0060 MT40	6.000	6/1	2,600	2,200	3,500	10/4	17.2	139	15.7	2,752	311	4,650	525	8,877	1,002
K402_0067 MT20	6.719	215/32	3,000	2,600	4,000	10/4	5.6	93	10.5	2,309	261	2,540	287	3,605	407
K402_0067 MT30	6.719	215/32	3,000	2,600	4,000	10/4	10.4	108	12.2	2,858	323	4,829	545	9,298	1,050
K402_0067 MT40	6.719	215/32	3,000	2,600	3,500	10/4	14.4	127	14.3	2,858	323	4,829	545	9,298	1,050
K402_0075 MT20	7.456	1849/248	2,600	2,200	3,500	10/4	6.4	111	12.5	2,563	289	2,819	318	4,154	469
K402_0075 MT30	7.456	1849/248	2,600	2,200	3,500	10/4	11.2	129	14.6	2,959	334	4,999	564	9,744	1,100
K402_0075 MT40	7.456	1849/248	2,600	2,200	3,500	10/4	15.2	150	17.0	2,959	334	4,999	564	9,744	1,100
K402_0084 MT20	8.377	645/77	3,000	2,600	4,000	10/4	4.3	107	12.1	2,879	325	3,167	358	4,347	491
K402_0084 MT30	8.377	645/77	3,000	2,600	4,000	10/4	9.1	120	13.6	3,076	347	5,197	587	9,744	1,100
K402_0084 MT40	8.377	645/77	3,000	2,600	3,500	10/4	13.1	134	15.1	3,076	347	5,197	587	9,744	1,100

Maximum Motor Shaft

Adapter	Diameter	Adapter	Diameter	Adapter	Diameter
KL1_MQ	16	MT10	19	MT40	48
KL2_MQ	19	MT20	24	MT50	60
		MT30	38		

¹⁾ Backlash shown "STANDARD/REDUCED".

²⁾ Maximum torque for continuous input RPM - horizontal output position.

³⁾ Maximum momentary torque for emergency stops or heavy shock load. Admissible stops per life of reducer = 1,000 stops maximum.

⁴⁾ dB(A) Measured at 1 meter distance with 3000 RPM input



"K" Series—Right Angle Helical/Bevel ServoFit® Modular System Selection Data



Part Number	Reducer Ratio i		Input RPM			Backlash arcmin $\Delta\phi$ ¹⁾	Input Inertia J ₁ kgcm ²	Torsional Stiffness per arcmin C ₂		Output Torque					
			Maximum							Nominal ²⁾		Acceleration		Peak ³⁾	
	Nom.	Exact	n _{1DBH}	n _{1DBV}	n _{1ZB}			M _{2N ≤ 2000 RPM}		M _{2B}		M _{2PEAK}			
								in.lbs.	Nm	in.lbs.	Nm	in.lbs.	Nm		
K402 with MT TriAdapt® Motor Adapter <i>Continued</i>										Noise Level ≤ 51 dB(A) ⁴⁾					
K402_0092 MT20	9.238	2365/256	3,000	2,600	4,000	10/4	4.9	128	14.4	3,175	358	3,493	394	4,956	560
K402_0092 MT30	9.238	2365/256	3,000	2,600	4,000	10/4	9.7	143	16.1	3,178	359	5,315	600	9,744	1,100
K402_0092 MT40	9.238	2365/256	3,000	2,600	3,500	10/4	13.7	159	17.9	3,178	359	5,315	600	9,744	1,100
K402_0100 MT20	10.10	1333/132	3,400	3,000	4,500	10/4	3.5	118	13.3	3,274	370	3,818	431	5,042	569
K402_0100 MT30	10.10	1333/132	3,400	3,000	4,000	10/4	8.3	128	14.5	3,274	370	5,315	600	9,744	1,100
K402_0100 MT40	10.10	1333/132	3,000	3,000	3,500	10/4	12.3	138	15.6	3,274	370	5,315	600	9,744	1,100
K402_0115 MT20	11.52	645/56	3,000	2,600	4,000	10/4	3.9	141	16.0	3,421	386	4,354	492	5,977	675
K402_0115 MT30	11.52	645/56	3,000	2,600	4,000	10/4	8.7	153	17.3	3,421	386	5,315	600	9,744	1,100
K402_0115 MT40	11.52	645/56	3,000	2,600	3,500	10/4	12.7	164	18.6	3,421	386	5,315	600	9,744	1,100
K402_0125 MT20	12.66	2924/231	3,400	3,000	4,500	10/4	2.8	127	14.4	3,530	399	4,785	540	6,113	690
K402_0125 MT30	12.66	2924/231	3,400	3,000	4,000	10/4	7.6	135	15.2	3,530	399	5,315	600	9,744	1,100
K402_0125 MT40	12.66	2924/231	3,000	3,000	3,500	10/4	11.6	142	16.1	3,530	399	5,315	600	9,744	1,100
K402_0140 MT20	13.89	1333/96	3,400	3,000	4,500	10/4	3.2	151	17.0	3,641	411	5,249	593	6,933	783
K402_0140 MT30	13.89	1333/96	3,400	3,000	4,000	10/4	8.0	160	18.0	3,641	411	5,315	600	9,744	1,100
K402_0140 MT40	13.89	1333/96	3,000	3,000	3,500	10/4	12.0	168	19.0	3,641	411	5,315	600	9,744	1,100
K402_0170 MT20	16.94	559/33	3,500	3,300	5,000	10/4	2.2	136	15.4	3,827	432	5,315	600	7,682	867
K402_0170 MT30	16.94	559/33	3,500	3,300	4,000	10/4	7.0	141	15.9	3,890	439	5,315	600	9,744	1,100
K402_0170 MT40	16.94	559/33	3,000	3,000	3,500	10/4	11.0	145	16.4	3,890	439	5,315	600	9,744	1,100
K402_0175 MT20	17.41	731/42	3,400	3,000	4,500	10/4	2.6	159	18.0	3,926	443	5,315	600	8,405	949
K402_0175 MT30	17.41	731/42	3,400	3,000	4,000	10/4	7.4	165	18.7	3,926	443	5,315	600	9,744	1,100
K402_0175 MT40	17.41	731/42	3,000	3,000	3,500	10/4	11.4	171	19.3	3,926	443	5,315	600	9,744	1,100
K402_0200 MT20	20.20	1333/66	3,500	3,300	5,000	10/4	1.9	140	15.8	3,964	447	5,315	600	8,842	998
K402_0200 MT30	20.20	1333/66	3,500	3,300	4,000	10/4	6.7	143	16.2	4,125	466	5,315	600	8,842	998
K402_0200 MT40	20.20	1333/66	3,000	3,000	3,500	10/4	10.7	147	16.5	4,125	466	5,315	600	8,842	998
K402_0230 MT20	23.29	559/24	3,500	3,300	5,000	10/4	2.1	166	18.8	4,326	488	5,315	600	9,744	1,100
K402_0230 MT30	23.29	559/24	3,500	3,300	4,000	10/4	6.9	170	19.2	4,326	488	5,315	600	9,744	1,100
K402_0230 MT40	23.29	559/24	3,000	3,000	3,500	10/4	10.9	173	19.6	4,326	488	5,315	600	9,744	1,100
K402_0250 MT20	25.28	4171/165	3,500	3,300	5,000	10/4	1.7	143	16.2	4,079	460	5,315	600	8,868	1,001
K402_0250 MT30	25.28	4171/165	3,500	3,300	4,000	10/4	6.5	146	16.4	4,434	501	5,315	600	8,868	1,001
K402_0250 MT40	25.28	4171/165	3,000	3,000	3,500	10/4	10.5	148	16.7	4,434	501	5,315	600	8,868	1,001
K402_0280 MT20	27.77	1333/48	3,500	3,300	5,000	10/4	1.9	169	19.1	4,587	518	5,315	600	9,744	1,100
K402_0280 MT30	27.77	1333/48	3,500	3,300	4,000	10/4	6.7	172	19.4	4,587	518	5,315	600	9,744	1,100
K402_0280 MT40	27.77	1333/48	3,000	3,000	3,500	10/4	10.7	174	19.7	4,587	518	5,315	600	9,744	1,100
K402_0340 MT20	33.68	4816/143	3,500	3,300	5,000	10/4	1.5	146	16.5	3,445	389	4,134	467	5,620	634
K402_0340 MT30	33.68	4816/143	3,500	3,300	4,000	10/4	6.3	147	16.6	3,445	389	4,134	467	5,620	634
K402_0350 MT20	34.76	4171/120	3,500	3,300	5,000	10/4	1.7	172	19.4	4,872	550	5,315	600	9,744	1,100
K402_0350 MT30	34.76	4171/120	3,500	3,300	4,000	10/4	6.5	173	19.6	4,872	550	5,315	600	9,744	1,100
K402_0350 MT40	34.76	4171/120	3,000	3,000	3,500	10/4	10.5	175	19.7	4,872	550	5,315	600	9,744	1,100
K402_0410 MT20	40.51	4902/121	3,500	3,300	5,000	10/4	1.4	147	16.6	2,729	308	3,274	370	5,457	616
K402_0410 MT30	40.51	4902/121	3,500	3,300	4,000	10/4	6.2	148	16.7	2,729	308	3,274	370	5,457	616
K402_0460 MT20	46.31	602/13	3,500	3,300	5,000	10/4	1.5	174	19.6	4,737	535	5,315	600	7,728	872
K402_0460 MT30	46.31	602/13	3,500	3,300	4,000	10/4	6.3	175	19.7	4,737	535	5,315	600	7,728	872
K402_0500 MT20	50.43	5547/110	3,500	3,300	5,000	10/4	1.4	148	16.7	2,387	270	2,865	323	4,064	459
K402_0560 MT20	55.71	2451/44	3,500	3,300	5,000	10/4	1.4	174	19.7	3,752	424	4,502	508	7,504	847
K402_0560 MT30	55.71	2451/44	3,500	3,300	4,000	10/4	6.2	175	19.8	3,752	424	4,502	508	7,504	847
K402_0690 MT20	69.34	5547/80	3,500	3,300	5,000	10/4	1.3	175	19.8	3,283	371	3,939	445	5,588	631

Index of Symbols: **MT** — Motor adapter with TriAdapt® coupling; **MQ** — Square Motor adapter

See Page 238 for Options and Part Number Configuration.





"K" Series—Right Angle Helical/Bevel ServoFit® Modular System Selection Data



Part Number	Reducer Ratio i		Input RPM			Backlash arcmins $\Delta\phi$ ¹⁾	Input Inertia J ₁ kgcm ²	Torsional Stiffness per arcm C ₂		Output Torque						
			Maximum							Nominal ²⁾		Acceleration		Peak ³⁾		
	Nom.		Exact		Continuous			Cyclic	M _{2N} ≤ 2000 RPM		M _{2B}		M _{2PEAK}			
	n _{1DBH}	n _{1DBV}	n _{1ZB}	in.lbs.	Nm			in.lbs.	Nm	in.lbs.	Nm	in.lbs.	Nm			
K403 with MT TriAdapt® Motor Adapter															Noise Level ≤ 51 dB(A) ⁴⁾	
K403_0320 MT20	32.39	2494/77	3,500	3,300	5,000	10/5	1.6	146	16.4	3,477	393	3,477	393	4,346	491	
K403_0360 MT20	35.72	13717/384	3,500	3,300	5,000	10/5	1.6	172	19.4	3,965	448	3,965	448	4,956	560	
K403_0390 MT20	39.05	38657/990	3,500	3,300	5,000	10/5	1.5	147	16.6	4,033	455	4,033	455	5,042	569	
K403_0450 MT20	44.54	1247/28	3,500	3,300	5,000	10/5	1.5	173	19.6	4,781	540	4,781	540	5,976	675	
K403_0490 MT20	48.94	169592/3465	3,500	3,300	5,000	10/5	1.5	148	16.7	4,872	550	4,890	552	6,112	690	
K403_0540 MT20	53.69	38657/720	3,500	3,300	5,000	10/5	1.5	174	19.7	4,872	550	5,315	600	6,932	783	
K403_0650 MT20	65.50	32422/495	3,500	3,300	5,000	10/5	1.4	148	16.8	4,872	550	5,315	600	7,681	867	
K403_0660 MT10	66.35	26273/396	3,600	3,300	5,000	10/5	0.7	148	16.8	2,406	272	2,406	272	3,007	340	
K403_0670 MT20	67.30	21199/315	3,500	3,300	5,000	10/5	1.4	175	19.8	4,872	550	5,315	600	8,404	949	
K403_0680 MT10	68.17	34357/504	3,600	3,300	5,000	10/5	0.7	175	19.7	2,472	279	2,472	279	3,090	349	
K403_0780 MT20	78.10	38657/495	3,500	3,300	5,000	10/5	1.4	149	16.8	4,872	550	5,315	600	8,842	998	
K403_0790 MT10	79.11	62651/792	3,600	3,300	5,000	10/5	0.7	149	16.8	2,869	324	2,869	324	3,586	405	
K403_0900 MT20	90.06	16211/180	3,500	3,300	5,000	10/5	1.4	176	19.8	4,872	550	5,315	600	9,744	1,100	
K403_0910 MT10	91.23	26273/288	3,600	3,300	5,000	10/5	0.7	176	19.8	3,308	373	3,308	373	4,135	467	
K403_1070 MT20	107.4	38657/360	3,500	3,300	5,000	10/5	1.4	176	19.8	4,872	550	5,315	600	9,744	1,100	
K403_1090 MT10	108.8	62651/576	3,600	3,300	5,000	10/5	0.7	176	19.8	3,944	445	3,944	445	4,930	557	
K403_1340 MT20	134.4	120959/900	3,500	3,300	5,000	10/5	1.4	176	19.9	4,872	550	5,315	600	9,744	1,100	
K403_1360 MT10	136.1	196037/1440	3,600	3,300	5,000	10/5	0.7	176	19.9	4,581	517	4,937	557	6,171	697	
K403_1790 MT20	179.1	34916/195	3,500	3,300	5,000	10/5	1.4	176	19.9	4,737	535	5,315	600	7,727	872	
K403_1810 MT10	181.4	14147/78	3,600	3,300	5,000	10/5	0.7	176	19.9	4,737	535	5,315	600	7,727	872	
K403_2150 MT20	215.4	23693/110	3,500	3,300	5,000	10/5	1.4	176	19.9	3,752	424	4,502	508	7,504	847	
K403_2180 MT10	218.2	38399/176	3,600	3,300	5,000	10/5	0.7	176	19.9	3,752	424	4,502	508	7,504	847	
K403_2720 MT10	271.6	86903/320	3,600	3,300	5,000	10/5	0.7	176	19.9	3,283	371	3,939	445	5,587	631	
K513 with MT TriAdapt® Motor Adapter															Noise Level ≤ 61 dB(A) ⁴⁾	
K513_0073 MT30	7.347	551/75	1,900	1,800	3,000	10/5	23.1	172	19.4	5,461	617	6,502	734	11,147	1,258	
K513_0073 MT40	7.347	551/75	1,900	1,800	3,000	10/5	27.1	213	24.0	5,461	617	8,858	1,000	11,147	1,258	
K513_0081 MT30	8.134	17081/2100	1,900	1,800	3,000	10/5	21.2	185	20.8	5,649	638	7,198	813	12,341	1,393	
K513_0081 MT40	8.134	17081/2100	1,900	1,800	3,000	10/5	25.2	222	25.0	5,649	638	8,858	1,000	12,341	1,393	
K513_0092 MT30	9.168	1421/155	1,900	1,800	3,000	10/5	18.2	198	22.3	5,879	664	8,113	916	13,494	1,523	
K513_0092 MT40	9.168	1421/155	1,900	1,800	3,000	10/5	22.2	230	26.0	5,879	664	8,858	1,000	13,494	1,523	
K513_0100 MT30	10.15	203/20	1,900	1,800	3,000	10/5	17.0	208	23.5	6,082	687	8,858	1,000	14,939	1,686	
K513_0100 MT40	10.15	203/20	1,900	1,800	3,000	10/5	21.0	237	26.7	6,082	687	8,858	1,000	14,939	1,686	
K513_0115 MT30	11.57	10759/930	2,300	2,200	3,600	10/5	14.5	220	24.8	6,353	717	8,858	1,000	15,944	1,800	
K513_0115 MT40	11.57	10759/930	2,300	2,200	3,500	10/5	18.5	244	27.5	6,353	717	8,858	1,000	15,944	1,800	
K513_0130 MT30	12.81	1537/120	2,300	2,200	3,600	10/5	13.7	228	25.7	6,573	742	8,858	1,000	15,944	1,800	
K513_0130 MT40	12.81	1537/120	2,300	2,200	3,500	10/5	17.7	248	28.0	6,573	742	8,858	1,000	15,944	1,800	
K513_0145 MT20	14.54	5887/405	2,300	2,200	3,600	10/5	7.2	219	24.7	4,924	556	5,416	611	7,682	867	
K513_0145 MT30	14.54	5887/405	2,300	2,200	3,600	10/5	12.0	236	26.6	6,856	774	8,858	1,000	15,944	1,800	
K513_0145 MT40	14.54	5887/405	2,300	2,200	3,500	10/5	16.0	253	28.6	6,856	774	8,858	1,000	15,944	1,800	
K513_0160 MT20	16.09	26071/1620	2,300	2,200	3,600	10/5	6.7	227	25.6	5,451	615	5,996	677	8,505	960	
K513_0160 MT30	16.09	26071/1620	2,300	2,200	3,600	10/5	11.5	242	27.3	7,092	801	8,858	1,000	15,944	1,800	
K513_0160 MT40	16.09	26071/1620	2,300	2,200	3,500	10/5	15.5	256	28.9	7,092	801	8,858	1,000	15,944	1,800	
K513_0175 MT20	17.48	6293/360	2,800	2,500	4,000	10/5	5.8	232	26.2	5,921	668	6,513	735	8,970	1,013	
K513_0175 MT30	17.48	6293/360	2,800	2,500	4,000	10/5	10.6	246	27.7	7,291	823	8,858	1,000	15,944	1,800	
K513_0175 MT40	17.48	6293/360	2,800	2,500	3,500	10/5	14.6	258	29.1	7,291	823	8,858	1,000	15,944	1,800	

¹⁾ Backlash shown "STANDARD/REDUCED".

²⁾ Maximum torque for continuous input RPM - horizontal output position.

³⁾ Maximum momentary torque for emergency stops or heavy shock load. Admissible stops per life of reducer = 1,000 stops maximum.

⁴⁾ dB(A) Measured at 1 meter distance with 3000 RPM input

Maximum Motor Shaft

Adapter	Diameter	Adapter	Diameter	Adapter	Diameter
KL1_MQ	16	MT10	19	MT40	48
KL2_MQ	19	MT20	24	MT50	60
		MT30	38		



"K" Series—Right Angle Helical/Bevel ServoFit® Modular System Selection Data



Part Number	Reducer Ratio i		Input RPM			Backlash arcmin $\Delta\phi$ ¹⁾	Input Inertia J ₁ kgcm ²	Torsional Stiffness per arcmin C ₂		Output Torque					
			Maximum							Nominal ²⁾		Acceleration		Peak ³⁾	
	Nom.	Exact	n _{1DBH}	n _{1DBV}	n _{1ZB}			M _{2N ≤ 2000 RPM}		M _{2B}		M _{2PEAK}			
								Continuous	Cyclic	in.lbs.	Nm	in.lbs.	Nm	in.lbs.	Nm
K513 with MT TriAdapt® Motor Adapter <i>Continued</i>										Noise Level ≤ 61 dB(A) ⁴⁾					
K513_0195 MT20	19.35	27869/1440	2,800	2,500	4,000	10/5	5.4	239	26.9	6,555	740	7,211	814	9,931	1,121
K513_0195 MT30	19.35	27869/1440	2,800	2,500	4,000	10/5	10.2	250	28.2	7,542	851	8,858	1,000	15,944	1,800
K513_0195 MT40	19.35	27869/1440	2,800	2,500	3,500	10/5	14.2	260	29.4	7,542	851	8,858	1,000	15,944	1,800
K513_0220 MT20	21.99	2639/120	2,800	2,500	4,000	10/5	4.4	245	27.7	7,089	800	8,194	925	10,782	1,217
K513_0220 MT30	21.99	2639/120	2,800	2,500	4,000	10/5	9.2	254	28.7	7,870	888	8,858	1,000	15,944	1,800
K513_0220 MT40	21.99	2639/120	2,800	2,500	3,500	10/5	13.2	263	29.6	7,870	888	8,858	1,000	15,944	1,800
K513_0240 MT20	24.35	11687/480	2,800	2,500	4,000	10/5	4.2	249	28.2	7,849	886	8,858	1,000	11,937	1,348
K513_0240 MT30	24.35	11687/480	2,800	2,500	4,000	10/5	9.0	257	29.0	7,972	900	8,858	1,000	15,944	1,800
K513_0240 MT40	24.35	11687/480	2,800	2,500	3,500	10/5	13.0	264	29.8	7,972	900	8,858	1,000	15,944	1,800
K513_0290 MT20	29.18	4669/160	3,400	3,000	4,500	10/5	3.3	256	28.8	7,525	850	8,858	1,000	13,530	1,527
K513_0290 MT30	29.18	4669/160	3,400	3,000	4,000	10/5	8.1	261	29.5	7,972	900	8,858	1,000	15,944	1,800
K513_0290 MT40	29.18	4669/160	3,000	3,000	3,500	10/5	12.1	266	30.0	7,972	900	8,858	1,000	15,944	1,800
K513_0320 MT20	32.31	20677/640	3,400	3,000	4,500	10/5	3.2	258	29.1	7,972	900	8,858	1,000	14,980	1,691
K513_0320 MT30	32.31	20677/640	3,400	3,000	4,000	10/5	8.0	263	29.7	7,972	900	8,858	1,000	15,944	1,800
K513_0320 MT40	32.31	20677/640	3,000	3,000	3,500	10/5	12.0	267	30.1	7,972	900	8,858	1,000	15,944	1,800
K513_0350 MT20	34.80	174/5	3,400	3,000	4,500	10/5	2.8	260	29.3	7,852	886	8,858	1,000	15,606	1,762
K513_0350 MT30	34.80	174/5	3,400	3,000	4,000	10/5	7.6	264	29.8	7,972	900	8,858	1,000	15,606	1,762
K513_0350 MT40	34.80	174/5	3,000	3,000	3,500	10/5	11.6	267	30.2	7,972	900	8,858	1,000	15,606	1,762
K513_0390 MT20	38.53	2697/70	3,400	3,000	4,500	10/5	2.7	262	29.5	7,972	900	8,858	1,000	15,944	1,800
K513_0390 MT30	38.53	2697/70	3,400	3,000	4,000	10/5	7.5	265	29.9	7,972	900	8,858	1,000	15,944	1,800
K513_0390 MT40	38.53	2697/70	3,000	3,000	3,500	10/5	11.5	268	30.2	7,972	900	8,858	1,000	15,944	1,800
K513_0440 MT20	43.50	87/2	3,400	3,000	4,500	10/5	2.3	264	29.8	7,972	900	8,858	1,000	15,944	1,800
K513_0440 MT30	43.50	87/2	3,400	3,000	4,000	10/5	7.1	266	30.1	7,972	900	8,858	1,000	15,944	1,800
K513_0440 MT40	43.50	87/2	3,000	3,000	3,500	10/5	11.1	268	30.3	7,972	900	8,858	1,000	15,944	1,800
K513_0480 MT20	48.16	2697/56	3,400	3,000	4,500	10/5	2.2	265	29.9	7,972	900	8,858	1,000	15,944	1,800
K513_0480 MT30	48.16	2697/56	3,400	3,000	4,000	10/5	7.0	267	30.1	7,972	900	8,858	1,000	15,944	1,800
K513_0480 MT40	48.16	2697/56	3,000	3,000	3,500	10/5	11.0	269	30.3	7,972	900	8,858	1,000	15,944	1,800
K513_0580 MT20	58.30	11368/195	3,400	3,000	4,500	10/5	1.9	267	30.1	7,972	900	8,858	1,000	15,944	1,800
K513_0580 MT30	58.30	11368/195	3,400	3,000	4,000	10/5	6.7	268	30.3	7,972	900	8,858	1,000	15,944	1,800
K513_0580 MT40	58.30	11368/195	3,000	3,000	3,500	10/5	10.7	269	30.4	7,972	900	8,858	1,000	15,944	1,800
K513_0650 MT20	64.54	12586/195	3,400	3,000	4,500	10/5	1.8	267	30.2	7,972	900	8,858	1,000	15,944	1,800
K513_0650 MT30	64.54	12586/195	3,400	3,000	4,000	10/5	6.6	269	30.3	7,972	900	8,858	1,000	15,944	1,800
K513_0650 MT40	64.54	12586/195	3,000	3,000	3,500	10/5	10.6	270	30.4	7,972	900	8,858	1,000	15,944	1,800
K513_0700 MT20	70.08	841/12	3,400	3,000	4,500	10/5	1.7	268	30.2	7,268	821	8,722	985	11,440	1,291
K513_0700 MT30	70.08	841/12	3,400	3,000	4,000	10/5	6.5	269	30.3	7,268	821	8,722	985	11,440	1,291
K513_0780 MT20	77.59	26071/336	3,400	3,000	4,500	10/5	1.7	268	30.3	7,972	900	8,858	1,000	12,666	1,430
K513_0780 MT30	77.59	26071/336	3,400	3,000	4,000	10/5	6.5	269	30.4	7,972	900	8,858	1,000	12,666	1,430
K513_0870 MT20	87.29	8729/100	3,400	3,000	4,500	10/5	1.5	269	30.3	6,105	689	7,326	827	12,211	1,378
K513_0870 MT30	87.29	8729/100	3,400	3,000	4,000	10/5	6.3	269	30.4	6,105	689	7,326	827	12,211	1,378
K513_0970 MT20	96.64	38657/400	3,400	3,000	4,500	10/5	1.5	269	30.4	6,761	763	8,113	916	13,522	1,527
K513_0970 MT30	96.64	38657/400	3,400	3,000	4,000	10/5	6.3	270	30.4	6,761	763	8,113	916	13,522	1,527

K514 with MT TriAdapt® Motor Adapter <i>Continued Next Page</i>										Noise Level ≤ 61 dB(A) ⁴⁾					
K514_0850 MT20	85.03	76531/900	3,400	3,000	4,500	10/6	1.6	269	30.3	7,972	900	8,625	974	10,781	1,217
K514_0940 MT20	94.15	338923/3600	3,400	3,000	4,500	10/6	1.6	269	30.4	7,972	900	8,858	1,000	11,936	1,347
K514_1130 MT20	112.8	135401/1200	3,400	3,000	4,500	10/6	1.5	269	30.4	7,972	900	8,858	1,000	13,529	1,527
K514_1250 MT20	124.9	599633/4800	3,400	3,000	4,500	10/6	1.5	270	30.4	7,972	900	8,858	1,000	14,979	1,691
K514_1350 MT20	134.6	3364/25	3,400	3,000	4,500	10/6	1.5	270	30.5	7,972	900	8,858	1,000	15,604	1,762
K514_1490 MT20	149.0	26071/175	3,400	3,000	4,500	10/6	1.5	270	30.5	7,972	900	8,858	1,000	15,944	1,800

Index of Symbols: **MT** — Motor adapter with TriAdapt® coupling; **MQ** — Square Motor adapter

See Page 238 for Options and Part Number Configuration.



"K" Series—Right Angle Helical/Bevel ServoFit® Modular System Selection Data



Part Number	Reducer Ratio i		Input RPM			Backlash arcmins $\Delta\phi$ ¹⁾	Input Inertia J ₁ kgcm ²	Torsional Stiffness per arcmin C ₂		Output Torque					
			Maximum							Nominal ²⁾		Acceleration		Peak ³⁾	
	Nom.		Exact		Continuous			Cyclic	M _{2N} ≤ 2000 RPM		M _{ZB}		M _{2PEAK}		
	n _{1DBH}	n _{1DBV}	n _{1ZB}	n _{1ZB}	in.lbs.			Nm	in.lbs.	Nm	in.lbs.	Nm	in.lbs.	Nm	
K514 with MT TriAdapt® Motor Adapter Continued															
Noise Level ≤ 61 dB(A) ⁴⁾															
K514_1680 MT20	168.2	841/5	3,400	3,000	4,500	10/6	1.4	270	30.5	7,972	900	8,858	1,000	15,944	1,800
K514_1860 MT20	186.2	26071/140	3,400	3,000	4,500	10/6	1.4	270	30.5	7,972	900	8,858	1,000	15,944	1,800
K514_2250 MT20	225.4	659344/2925	3,400	3,000	4,500	10/6	1.4	270	30.5	7,972	900	8,858	1,000	15,944	1,800
K514_2500 MT20	249.6	729988/2925	3,400	3,000	4,500	10/6	1.4	270	30.5	7,972	900	8,858	1,000	15,944	1,800
K514_2710 MT20	271.0	24389/90	3,400	3,000	4,500	10/6	1.4	270	30.5	7,268	821	8,722	985	11,439	1,291
K514_3000 MT20	300.0	756059/2520	3,400	3,000	4,500	10/6	1.4	270	30.5	7,972	900	8,858	1,000	12,665	1,430
K514_3380 MT20	337.5	253141/750	3,400	3,000	4,500	10/6	1.4	270	30.5	6,105	689	7,326	827	12,211	1,378
K514_3740 MT20	373.7	1121053/3000	3,400	3,000	4,500	10/6	1.4	270	30.5	6,761	763	8,113	916	13,522	1,527

K613 with MT TriAdapt® Motor Adapter Continued Next Page															
Noise Level ≤ 61 dB(A) ⁴⁾															
K613_0073 MT30	7.323	19215/2624	1,800	1,700	2,900	10/5	37.9	216	24.4	5,891	665	6,480	732	11,477	1,296
K613_0073 MT40	7.323	19215/2624	1,800	1,700	2,900	10/5	41.9	285	32.2	7,208	814	9,182	1,037	11,477	1,296
K613_0073 MT50	7.323	19215/2624	1,800	1,700	2,900	10/5	51.9	354	39.9	7,208	814	12,178	1,375	21,932	2,476
K613_0081 MT30	8.107	85095/10496	1,800	1,700	2,900	10/5	34.8	236	26.6	6,522	736	7,174	810	12,706	1,434
K613_0081 MT40	8.107	85095/10496	1,800	1,700	2,900	10/5	38.8	301	33.9	7,457	842	10,165	1,148	12,706	1,434
K613_0081 MT50	8.107	85095/10496	1,800	1,700	2,900	10/5	48.8	361	40.8	7,457	842	12,597	1,422	24,280	2,741
K613_0091 MT30	9.081	20923/2304	1,800	1,700	2,900	10/5	28.8	257	29.0	7,306	825	8,036	907	13,823	1,561
K613_0091 MT40	9.081	20923/2304	1,800	1,700	2,900	10/5	32.8	317	35.7	7,744	874	11,059	1,248	13,823	1,561
K613_0091 MT50	9.081	20923/2304	1,800	1,700	2,900	10/5	42.8	369	41.6	7,744	874	13,083	1,477	25,688	2,900
K613_0100 MT30	10.05	92659/9216	1,800	1,700	2,900	10/5	26.8	275	31.1	8,012	904	8,897	1,004	15,305	1,728
K613_0100 MT40	10.05	92659/9216	1,800	1,700	2,900	10/5	30.8	329	37.2	8,012	904	12,244	1,382	15,305	1,728
K613_0100 MT50	10.05	92659/9216	1,800	1,700	2,900	10/5	40.8	374	42.2	8,012	904	13,534	1,528	25,688	2,900
K613_0115 MT30	11.41	22631/1984	2,200	2,000	3,200	10/5	22.1	296	33.4	8,356	943	10,094	1,140	16,789	1,895
K613_0115 MT40	11.41	22631/1984	2,200	2,000	3,200	10/5	26.1	343	38.7	8,356	943	13,431	1,516	16,789	1,895
K613_0115 MT50	11.41	22631/1984	2,200	2,000	3,000	10/5	36.1	379	42.8	8,356	943	13,431	1,516	16,789	1,895
K613_0125 MT30	12.63	3233/256	2,200	2,000	3,200	10/5	20.9	311	35.1	8,644	976	11,176	1,262	18,588	2,098
K613_0125 MT40	12.63	3233/256	2,200	2,000	3,200	10/5	24.9	352	39.7	8,644	976	14,173	1,600	18,588	2,098
K613_0125 MT50	12.63	3233/256	2,200	2,000	3,000	10/5	34.9	383	43.2	8,644	976	14,173	1,600	18,588	2,098
K613_0145 MT30	14.33	12383/864	2,200	2,000	3,200	10/5	17.4	327	36.9	9,017	1,018	12,683	1,432	20,378	2,301
K613_0145 MT40	14.33	12383/864	2,200	2,000	3,200	10/5	21.4	361	40.8	9,017	1,018	14,173	1,600	20,378	2,301
K613_0145 MT50	14.33	12383/864	2,200	2,000	3,000	10/5	31.4	386	43.6	9,017	1,018	14,173	1,600	20,378	2,301
K613_0160 MT30	15.87	54839/3456	2,200	2,000	3,200	10/5	16.6	338	38.2	9,328	1,053	14,042	1,585	22,562	2,547
K613_0160 MT40	15.87	54839/3456	2,200	2,000	3,200	10/5	20.6	368	41.5	9,328	1,053	14,173	1,600	22,562	2,547
K613_0160 MT50	15.87	54839/3456	2,200	2,000	3,000	10/5	30.6	389	43.9	9,328	1,053	14,173	1,600	22,562	2,547
K613_0170 MT20	17.16	549/32	2,600	2,300	3,600	10/5	9.7	319	36.0	5,811	656	6,392	722	9,119	1,029
K613_0170 MT30	17.16	549/32	2,600	2,300	3,600	10/5	14.5	346	39.0	9,574	1,081	14,173	1,600	23,519	2,655
K613_0170 MT40	17.16	549/32	2,600	2,300	3,500	10/5	18.5	372	42.0	9,574	1,081	14,173	1,600	23,519	2,655
K613_0170 MT50	17.16	549/32	2,500	2,300	3,000	10/5	28.5	390	44.1	9,574	1,081	14,173	1,600	23,519	2,655
K613_0190 MT20	18.99	17019/896	2,600	2,300	3,600	10/5	9.2	331	37.4	6,434	726	7,077	799	10,095	1,140
K613_0190 MT30	18.99	17019/896	2,600	2,300	3,600	10/5	14.0	355	40.0	9,904	1,118	14,173	1,600	25,688	2,900
K613_0190 MT40	18.99	17019/896	2,600	2,300	3,500	10/5	18.0	377	42.5	9,904	1,118	14,173	1,600	25,688	2,900
K613_0190 MT50	18.99	17019/896	2,500	2,300	3,000	10/5	28.0	392	44.2	9,904	1,118	14,173	1,600	25,688	2,900
K613_0220 MT20	21.68	5551/256	2,600	2,300	3,600	10/5	7.3	345	39.0	7,345	829	8,080	912	11,090	1,252
K613_0220 MT30	21.68	5551/256	2,600	2,300	3,600	10/5	12.1	364	41.1	10,351	1,169	14,173	1,600	25,688	2,900
K613_0220 MT40	21.68	5551/256	2,600	2,300	3,500	10/5	16.1	382	43.1	10,351	1,169	14,173	1,600	25,688	2,900
K613_0220 MT50	21.68	5551/256	2,500	2,300	3,000	10/5	26.1	394	44.4	10,351	1,169	14,173	1,600	25,688	2,900
K613_0240 MT20	24.01	24583/1024	2,600	2,300	3,600	10/5	6.9	354	40.0	8,132	918	8,945	1,010	12,278	1,386
K613_0240 MT30	24.01	24583/1024	2,600	2,300	3,600	10/5	11.7	370	41.8	10,708	1,209	14,173	1,600	25,688	2,900
K613_0240 MT40	24.01	24583/1024	2,600	2,300	3,500	10/5	15.7	385	43.5	10,708	1,209	14,173	1,600	25,688	2,900
K613_0240 MT50	24.01	24583/1024	2,500	2,300	3,000	10/5	25.7	395	44.6	10,708	1,209	14,173	1,600	25,688	2,900

¹⁾ Backlash shown "STANDARD/REDUCED".
²⁾ Maximum torque for continuous input RPM - horizontal output position.
³⁾ Maximum momentary torque for emergency stops or heavy shock load. Admissible stops per life of reducer = 1,000 stops maximum.
⁴⁾ dB(A) Measured at 1 meter distance with 3000 RPM input

Maximum Motor Shaft					
Adapter	Diameter	Adapter	Diameter	Adapter	Diameter
KL1_MQ	16	MT10	19	MT40	48
KL2_MQ	19	MT20	24	MT50	60
		MT30	38		



"K" Series—Right Angle Helical/Bevel ServoFit® Modular System Selection Data



Part Number	Reducer Ratio i		Input RPM			Backlash arcmins $\Delta\phi$ ¹⁾	Input Inertia J ₁ kgcm ²	Torsional Stiffness per arcmin C ₂		Output Torque					
			Maximum							Nominal ²⁾		Acceleration		Peak ³⁾	
	Nom.	Exact	n _{1DBH}	n _{1DBV}	n _{1ZB}			M _{2N ≤ 2000 RPM}		M _{2B}		M _{2PEAK}			
								Continuous	Cyclic	in.lbs.	Nm	in.lbs.	Nm	in.lbs.	Nm
K613 with MT TriAdapt® Motor Adapter <i>Continued</i>										Noise Level ≤ 61 dB(A) ⁴⁾					
K613_0290 MT20	28.77	29463/1024	3,100	2,800	4,000	10/5	5.1	367	41.4	8,786	992	10,721	1,210	13,916	1,571
K613_0290 MT30	28.77	29463/1024	3,100	2,800	4,000	10/5	9.9	379	42.7	11,374	1,284	14,173	1,600	25,688	2,900
K613_0290 MT40	28.77	29463/1024	3,000	2,800	3,500	10/5	13.9	389	43.9	11,374	1,284	14,173	1,600	25,688	2,900
K613_0290 MT50	28.77	29463/1024	2,500	2,500	3,000	10/5	23.9	396	44.7	11,374	1,284	14,173	1,600	25,688	2,900
K613_0320 MT20	31.86	130479/4096	3,100	2,800	4,000	10/5	4.9	372	42.0	9,727	1,098	11,869	1,340	15,407	1,739
K613_0320 MT30	31.86	130479/4096	3,100	2,800	4,000	10/5	9.7	382	43.2	11,767	1,328	14,173	1,600	25,688	2,900
K613_0320 MT40	31.86	130479/4096	3,000	2,800	3,500	10/5	13.7	391	44.2	11,767	1,328	14,173	1,600	25,688	2,900
K613_0320 MT50	31.86	130479/4096	2,500	2,500	3,000	10/5	23.7	397	44.8	11,767	1,328	14,173	1,600	25,688	2,900
K613_0350 MT20	34.61	35441/1024	3,100	2,800	4,000	10/5	4.1	376	42.5	8,925	1,008	12,838	1,449	16,048	1,812
K613_0350 MT30	34.61	35441/1024	3,100	2,800	4,000	10/5	8.9	385	43.4	12,097	1,366	14,173	1,600	25,688	2,900
K613_0350 MT40	34.61	35441/1024	3,000	2,800	3,500	10/5	12.9	392	44.3	12,097	1,366	14,173	1,600	25,688	2,900
K613_0350 MT50	34.61	35441/1024	2,500	2,500	3,000	10/5	22.9	397	44.8	12,097	1,366	14,173	1,600	25,688	2,900
K613_0380 MT20	38.32	156953/4096	3,100	2,800	4,000	10/5	3.9	380	42.9	9,882	1,116	14,173	1,600	17,767	2,006
K613_0380 MT30	38.32	156953/4096	3,100	2,800	4,000	10/5	8.7	387	43.7	12,514	1,413	14,173	1,600	25,688	2,900
K613_0380 MT40	38.32	156953/4096	3,000	2,800	3,500	10/5	12.7	394	44.4	12,514	1,413	14,173	1,600	25,688	2,900
K613_0380 MT50	38.32	156953/4096	2,500	2,500	3,000	10/5	22.7	398	44.9	12,514	1,413	14,173	1,600	25,688	2,900
K613_0430 MT20	43.11	8967/208	3,100	2,800	4,000	10/5	3.2	384	43.4	9,168	1,035	14,173	1,600	19,048	2,150
K613_0430 MT30	43.11	8967/208	3,100	2,800	4,000	10/5	8.0	390	44.0	12,844	1,450	14,173	1,600	19,048	2,150
K613_0430 MT40	43.11	8967/208	3,000	2,800	3,500	10/5	12.0	395	44.6	12,844	1,450	14,173	1,600	19,048	2,150
K613_0480 MT20	47.73	39711/832	3,100	2,800	4,000	10/5	3.1	387	43.7	10,150	1,146	14,173	1,600	21,089	2,381
K613_0480 MT30	47.73	39711/832	3,100	2,800	4,000	10/5	7.9	392	44.2	12,844	1,450	14,173	1,600	21,089	2,381
K613_0480 MT40	47.73	39711/832	3,000	2,800	3,500	10/5	11.9	396	44.7	12,844	1,450	14,173	1,600	21,089	2,381
K613_0580 MT20	57.55	29463/512	3,100	2,800	4,000	10/5	2.4	391	44.1	9,542	1,077	14,173	1,600	23,893	2,697
K613_0580 MT30	57.55	29463/512	3,100	2,800	4,000	10/5	7.2	394	44.5	12,844	1,450	14,173	1,600	23,893	2,697
K613_0580 MT40	57.55	29463/512	3,000	2,800	3,500	10/5	11.2	397	44.8	12,844	1,450	14,173	1,600	23,893	2,697
K613_0640 MT20	63.71	130479/2048	3,100	2,800	4,000	10/5	2.4	392	44.3	10,565	1,193	14,173	1,600	25,688	2,900
K613_0640 MT30	63.71	130479/2048	3,100	2,800	4,000	10/5	7.2	395	44.6	12,844	1,450	14,173	1,600	25,688	2,900
K613_0640 MT40	63.71	130479/2048	3,000	2,800	3,500	10/5	11.2	397	44.9	12,844	1,450	14,173	1,600	25,688	2,900
K613_0690 MT20	68.77	28609/416	3,100	2,800	4,000	10/5	2.1	393	44.4	9,750	1,101	13,967	1,577	23,278	2,628
K613_0690 MT30	68.77	28609/416	3,100	2,800	4,000	10/5	6.9	396	44.7	11,639	1,314	13,967	1,577	23,278	2,628
K613_0690 MT40	68.77	28609/416	3,000	2,800	3,500	10/5	10.9	398	44.9	11,639	1,314	13,967	1,577	23,278	2,628
K613_0760 MT20	76.14	126697/1664	3,100	2,800	4,000	10/5	2.0	394	44.5	10,794	1,219	14,173	1,600	25,688	2,900
K613_0760 MT30	76.14	126697/1664	3,100	2,800	4,000	10/5	6.8	396	44.7	12,844	1,450	14,173	1,600	25,688	2,900
K613_0760 MT40	76.14	126697/1664	3,000	2,800	3,500	10/5	10.8	398	44.9	12,844	1,450	14,173	1,600	25,688	2,900
K613_0860 MT20	86.18	66185/768	3,100	2,800	4,000	10/5	1.8	395	44.6	8,600	971	10,320	1,165	13,893	1,568
K613_0860 MT30	86.18	66185/768	3,100	2,800	4,000	10/5	6.6	397	44.8	8,600	971	10,320	1,165	13,893	1,568
K613_0950 MT20	95.41	293105/3072	3,100	2,800	4,000	10/5	1.8	396	44.7	9,524	1,075	11,429	1,290	15,382	1,736
K613_0950 MT30	95.41	293105/3072	3,100	2,800	4,000	10/5	6.6	397	44.9	9,524	1,075	11,429	1,290	15,382	1,736
K614 with MT TriAdapt® Motor Adapter <i>Continued Next Page</i>										Noise Level ≤ 61 dB(A) ⁴⁾					
K614_0840 MT20	83.84	160979/1920	3,100	2,800	4,000	10/6	1.8	395	44.6	8,871	1,001	8,871	1,001	11,088	1,252
K614_0930 MT20	92.83	712907/7680	3,100	2,800	4,000	10/6	1.7	396	44.7	9,821	1,109	9,821	1,109	12,277	1,386
K614_1110 MT20	111.3	284809/2560	3,100	2,800	4,000	10/6	1.6	397	44.8	11,132	1,257	11,132	1,257	13,915	1,571
K614_1230 MT20	123.2	1261297/10240	3,100	2,800	4,000	10/6	1.6	397	44.9	12,325	1,391	12,325	1,391	15,406	1,739
K614_1340 MT20	133.8	1027789/7680	3,100	2,800	4,000	10/6	1.6	398	44.9	12,837	1,449	12,837	1,449	16,046	1,812
K614_1480 MT20	148.2	4551637/30720	3,100	2,800	4,000	10/6	1.5	398	44.9	12,844	1,450	14,173	1,600	17,766	2,006
K614_1670 MT20	166.7	86681/520	3,100	2,800	4,000	10/6	1.5	398	45.0	12,844	1,450	14,173	1,600	19,047	2,150
K614_1850 MT20	184.6	383873/2080	3,100	2,800	4,000	10/6	1.5	399	45.0	12,844	1,450	14,173	1,600	21,087	2,381
K614_2230 MT20	222.5	284809/1280	3,100	2,800	4,000	10/6	1.4	399	45.0	12,844	1,450	14,173	1,600	23,891	2,697

Index of Symbols: **MT** — Motor adapter with TriAdapt® coupling; **MQ** — Square Motor adapter

See Page 238 for Options and Part Number Configuration.



"K" Series—Right Angle Helical/Bevel ServoFit® Modular System Selection Data



Part Number	Reducer Ratio i		Input RPM			Backlash arcmins $\Delta\phi$ ¹⁾	Input Inertia J ₁ kgcm ²	Torsional Stiffness per arcmin C ₂		Output Torque					
			Maximum							Nominal ²⁾		Acceleration		Peak ³⁾	
	Nom.		Exact		Continuous			Cyclic	M _{2N} ≤ 2000 RPM		M _{2B}		M _{2PEAK}		
	n _{1DBH}	n _{1DBV}	n _{1ZB}	n _{1ZC}	in.lbs.			Nm	in.lbs.	Nm	in.lbs.	Nm	in.lbs.	Nm	
K614 with MT TriAdapt® Motor Adapter Continued										Noise Level ≤ 61 dB(A) ⁴⁾					
K614_2460 MT20	246.3	1261297/5120	3,100	2,800	4,000	10/6	1.4	399	45.0	12,844	1,450	14,173	1,600	25,688	2,900
K614_2660 MT20	265.9	829661/3120	3,100	2,800	4,000	10/6	1.4	399	45.0	11,639	1,314	13,967	1,577	23,278	2,628
K614_2940 MT20	294.4	3674213/12480	3,100	2,800	4,000	10/6	1.4	399	45.1	12,844	1,450	14,173	1,600	25,688	2,900
K614_3330 MT20	333.2	383873/1152	3,100	2,800	4,000	10/6	1.4	399	45.1	8,600	971	10,320	1,165	13,892	1,568
K614_3690 MT20	368.9	1700009/4608	3,100	2,800	4,000	10/6	1.4	399	45.1	9,524	1,075	11,429	1,290	15,380	1,736
K713 with MT TriAdapt® Motor Adapter Continued Next Page										Noise Level ≤ 59 dB(A) ⁴⁾					
K713_0076 MT30	7.563	19845/2624	1,700	1,600	2,700	10/5	71.2	295	33.4	6,084	687	6,693	756	12,169	1,374
K713_0076 MT40	7.563	19845/2624	1,700	1,600	2,700	10/5	75.2	428	48.3	9,837	1,111	9,837	1,111	12,297	1,388
K713_0076 MT50	7.563	19845/2624	1,700	1,600	2,700	10/5	85.2	590	66.7	11,924	1,346	18,798	2,122	23,498	2,653
K713_0084 MT30	8.373	87885/10496	1,700	1,600	2,700	10/5	66.3	331	37.4	6,736	760	7,410	836	13,472	1,521
K713_0084 MT40	8.373	87885/10496	1,700	1,600	2,700	10/5	70.3	463	52.2	10,891	1,230	10,891	1,230	13,614	1,537
K713_0084 MT50	8.373	87885/10496	1,700	1,600	2,700	10/5	80.3	611	68.9	12,336	1,393	20,812	2,349	26,014	2,937
K713_0092 MT30	9.188	147/16	1,700	1,600	2,700	10/5	54.4	365	41.2	7,392	834	8,131	918	14,515	1,639
K713_0092 MT40	9.188	147/16	1,700	1,600	2,700	10/5	58.4	492	55.6	11,612	1,311	11,612	1,311	14,515	1,639
K713_0092 MT50	9.188	147/16	1,700	1,600	2,700	10/5	68.4	627	70.7	12,724	1,436	21,495	2,427	27,736	3,131
K713_0100 MT30	10.17	651/64	1,700	1,600	2,700	10/5	51.2	401	45.3	8,183	924	9,002	1,016	16,069	1,814
K713_0100 MT40	10.17	651/64	1,700	1,600	2,700	10/5	55.2	523	59.0	12,855	1,451	12,855	1,451	16,069	1,814
K713_0100 MT50	10.17	651/64	1,700	1,600	2,700	10/5	65.2	642	72.4	13,163	1,486	22,237	2,510	30,706	3,467
K713_0120 MT30	11.78	23373/1984	2,000	1,900	3,000	10/5	39.2	452	51.0	9,478	1,070	10,425	1,177	17,928	2,024
K713_0120 MT40	11.78	23373/1984	2,000	1,900	3,000	10/5	43.2	562	63.4	13,823	1,561	14,342	1,619	17,928	2,024
K713_0120 MT50	11.78	23373/1984	2,000	1,900	3,000	10/5	53.2	660	74.5	13,823	1,561	23,031	2,600	34,258	3,868
K713_0130 MT30	13.04	3339/256	2,000	1,900	3,000	10/5	37.2	485	54.8	10,493	1,185	11,542	1,303	19,849	2,241
K713_0130 MT40	13.04	3339/256	2,000	1,900	3,000	10/5	41.2	585	66.1	14,300	1,614	15,879	1,793	19,849	2,241
K713_0130 MT50	13.04	3339/256	2,000	1,900	3,000	10/5	51.2	670	75.6	14,300	1,614	23,031	2,600	37,928	4,282
K713_0150 MT30	14.80	1421/96	2,000	1,900	3,000	10/5	29.8	523	59.1	11,908	1,344	13,099	1,479	21,761	2,457
K713_0150 MT40	14.80	1421/96	2,000	1,900	3,000	10/5	33.8	611	68.9	14,916	1,684	17,409	1,965	21,761	2,457
K713_0150 MT50	14.80	1421/96	2,000	1,900	3,000	10/5	43.8	680	76.8	14,916	1,684	23,031	2,600	41,582	4,694
K713_0165 MT30	16.39	6293/384	2,000	1,900	3,000	10/5	28.5	551	62.2	13,184	1,488	14,502	1,637	24,092	2,720
K713_0165 MT40	16.39	6293/384	2,000	1,900	3,000	10/5	32.5	628	70.9	15,431	1,742	19,274	2,176	24,092	2,720
K713_0165 MT50	16.39	6293/384	2,000	1,900	3,000	10/5	42.5	687	77.6	15,431	1,742	23,031	2,600	42,518	4,800
K713_0185 MT30	18.28	26901/1472	2,400	2,200	3,400	10/5	23.8	577	65.2	14,702	1,660	16,172	1,826	25,811	2,914
K713_0185 MT40	18.28	26901/1472	2,400	2,200	3,400	10/5	27.8	644	72.7	16,001	1,806	20,649	2,331	25,811	2,914
K713_0185 MT50	18.28	26901/1472	2,400	2,200	3,000	10/5	37.8	693	78.2	16,001	1,806	23,031	2,600	42,518	4,800
K713_0200 MT30	20.23	119133/5888	2,400	2,200	3,400	10/5	23.0	599	67.6	16,277	1,838	17,905	2,021	28,576	3,226
K713_0200 MT40	20.23	119133/5888	2,400	2,200	3,400	10/5	27.0	657	74.1	16,554	1,869	22,861	2,581	28,576	3,226
K713_0200 MT50	20.23	119133/5888	2,400	2,200	3,000	10/5	37.0	698	78.8	16,554	1,869	23,031	2,600	42,518	4,800
K713_0230 MT30	22.74	14553/640	2,400	2,200	3,400	10/5	18.8	621	70.1	16,193	1,828	20,122	2,272	30,795	3,476
K713_0230 MT40	22.74	14553/640	2,400	2,200	3,400	10/5	22.8	669	75.5	17,211	1,943	23,031	2,600	30,795	3,476
K713_0230 MT50	22.74	14553/640	2,400	2,200	3,000	10/5	32.8	702	79.3	17,211	1,943	23,031	2,600	42,518	4,800
K713_0250 MT30	25.18	64449/2560	2,400	2,200	3,400	10/5	18.2	637	71.9	17,804	2,010	22,278	2,515	34,094	3,849
K713_0250 MT40	25.18	64449/2560	2,400	2,200	3,400	10/5	22.2	677	76.5	17,804	2,010	23,031	2,600	34,094	3,849
K713_0250 MT50	25.18	64449/2560	2,400	2,200	3,000	10/5	32.2	705	79.6	17,804	2,010	23,031	2,600	42,518	4,800
K713_0290 MT30	29.29	7497/256	2,900	2,600	3,800	10/5	14.5	656	74.1	17,161	1,937	23,031	2,600	37,773	4,264
K713_0290 MT40	29.29	7497/256	2,900	2,600	3,500	10/5	18.5	688	77.6	18,725	2,114	23,031	2,600	37,773	4,264
K713_0290 MT50	29.29	7497/256	2,500	2,500	3,000	10/5	28.5	709	80.0	18,725	2,114	23,031	2,600	42,518	4,800
K713_0320 MT30	32.42	33201/1024	2,900	2,600	3,800	10/5	14.2	667	75.3	19,000	2,145	23,031	2,600	41,821	4,721
K713_0320 MT40	32.42	33201/1024	2,900	2,600	3,500	10/5	18.2	693	78.3	19,371	2,187	23,031	2,600	41,821	4,721
K713_0320 MT50	32.42	33201/1024	2,500	2,500	3,000	10/5	28.2	711	80.2	19,371	2,187	23,031	2,600	42,518	4,800

1) Backlash shown "STANDARD/REDUCED".
 2) Maximum torque for continuous input RPM - horizontal output position.
 3) Maximum momentary torque for emergency stops or heavy shock load.
 Admissible stops per life of reducer = 1,000 stops maximum.
 4) dB(A) Measured at 1 meter distance with 3000 RPM input

Maximum Motor Shaft

Adapter	Diameter	Adapter	Diameter	Adapter	Diameter
KL1_MQ	16	MT10	19	MT40	48
KL2_MQ	19	MT20	24	MT50	60
		MT30	38		



"K" Series—Right Angle Helical/Bevel ServoFit® Modular System Selection Data



Part Number	Reducer Ratio i		Input RPM			Backlash arcmins $\Delta\phi$ ¹⁾	Input Inertia J ₁ kgcm ²	Torsional Stiffness per arcmin C ₂		Output Torque					
			Maximum							Nominal ²⁾		Acceleration		Peak ³⁾	
	Nom.	Exact	n _{1DBH}	n _{1DBV}	n _{1ZB}			M _{2N ≤ 2000 RPM}		M _{2B}		M _{2PEAK}			
								Continuous	Cyclic	in.lbs.	Nm	in.lbs.	Nm	in.lbs.	Nm
K713 with MT TriAdapt® Motor Adapter <i>Continued</i> Noise Level ≤ 59 dB(A) ⁴⁾															
K713_0350 MT30	35.44	567/16	2,900	2,600	3,800	10/5	12.2	675	76.2	17,666	1,994	23,031	2,600	42,518	4,800
K713_0350 MT40	35.44	567/16	2,900	2,600	3,500	10/5	16.2	697	78.7	19,954	2,253	23,031	2,600	42,518	4,800
K713_0350 MT50	35.44	567/16	2,500	2,500	3,000	10/5	26.2	712	80.4	19,954	2,253	23,031	2,600	42,518	4,800
K713_0390 MT30	39.23	2511/64	2,900	2,600	3,800	10/5	12.0	683	77.1	19,558	2,208	23,031	2,600	42,518	4,800
K713_0390 MT40	39.23	2511/64	2,900	2,600	3,500	10/5	16.0	701	79.2	20,642	2,330	23,031	2,600	42,518	4,800
K713_0390 MT50	39.23	2511/64	2,500	2,500	3,000	10/5	26.0	713	80.5	20,642	2,330	23,031	2,600	42,518	4,800
K713_0450 MT30	45.05	37485/832	2,900	2,600	3,800	10/5	10.2	691	78.0	18,248	2,060	23,031	2,600	42,518	4,800
K713_0450 MT40	45.05	37485/832	2,900	2,600	3,500	10/5	14.2	705	79.6	21,259	2,400	23,031	2,600	42,518	4,800
K713_0450 MT50	45.05	37485/832	2,500	2,500	3,000	10/5	24.2	715	80.7	21,259	2,400	23,031	2,600	42,518	4,800
K713_0500 MT30	49.88	166005/3328	2,900	2,600	3,800	10/5	10.1	696	78.6	20,203	2,281	23,031	2,600	42,518	4,800
K713_0500 MT40	49.88	166005/3328	2,900	2,600	3,500	10/5	14.1	708	79.9	21,259	2,400	23,031	2,600	42,518	4,800
K713_0500 MT50	49.88	166005/3328	2,500	2,500	3,000	10/5	24.1	715	80.8	21,259	2,400	23,031	2,600	42,518	4,800
K713_0590 MT30	58.57	7497/128	2,900	2,600	3,800	10/5	8.7	702	79.3	19,023	2,148	23,031	2,600	42,518	4,800
K713_0590 MT40	58.57	7497/128	2,900	2,600	3,500	10/5	12.7	711	80.3	21,259	2,400	23,031	2,600	42,518	4,800
K713_0590 MT50	58.57	7497/128	2,500	2,500	3,000	10/5	22.7	716	80.9	21,259	2,400	23,031	2,600	42,518	4,800
K713_0650 MT30	64.85	33201/512	2,900	2,600	3,800	10/5	8.6	705	79.6	21,061	2,378	23,031	2,600	42,518	4,800
K713_0650 MT40	64.85	33201/512	2,900	2,600	3,500	10/5	12.6	712	80.4	21,259	2,400	23,031	2,600	42,518	4,800
K713_0650 MT50	64.85	33201/512	2,500	2,500	3,000	10/5	22.6	717	80.9	21,259	2,400	23,031	2,600	42,518	4,800
K713_0710 MT30	71.20	4557/64	2,900	2,600	3,800	10/5	7.9	707	79.9	19,244	2,173	23,031	2,600	29,355	3,314
K713_0710 MT40	71.20	4557/64	2,900	2,600	3,500	10/5	11.9	713	80.5	19,244	2,173	23,031	2,600	29,355	3,314
K713_0790 MT30	78.83	20181/256	2,900	2,600	3,800	10/5	7.8	710	80.1	21,259	2,400	23,031	2,600	32,500	3,669
K713_0790 MT40	78.83	20181/256	2,900	2,600	3,500	10/5	11.8	714	80.7	21,259	2,400	23,031	2,600	32,500	3,669
K713_0890 MT30	89.00	22785/256	2,900	2,600	3,800	10/5	7.3	712	80.3	14,803	1,671	17,764	2,005	29,607	3,342
K713_0890 MT40	89.00	22785/256	2,900	2,600	3,500	10/5	11.3	715	80.8	14,803	1,671	17,764	2,005	29,607	3,342
K713_0990 MT30	98.54	100905/1024	2,900	2,600	3,800	10/5	7.2	713	80.5	16,394	1,851	19,672	2,221	32,787	3,701
K713_0990 MT40	98.54	100905/1024	2,900	2,600	3,500	10/5	11.2	716	80.8	16,394	1,851	19,672	2,221	32,787	3,701
K714 with MT TriAdapt® Motor Adapter <i>Continued Next Page</i> Noise Level ≤ 59 dB(A) ⁴⁾															
K714_0890 MT30	89.06	227997/2560	2,900	2,600	3,800	10/6	7.3	712	80.3	21,259	2,400	23,031	2,600	30,792	3,476
K714_0990 MT30	98.60	1009701/10240	2,900	2,600	3,800	10/6	7.2	713	80.5	21,259	2,400	23,031	2,600	34,091	3,849
K714_1130 MT20	113.2	72471/640	2,900	2,600	3,800	10/6	1.9	712	80.3	11,715	1,323	11,715	1,323	14,644	1,653
K714_1150 MT30	114.7	117453/1024	2,900	2,600	3,800	10/6	7.0	714	80.7	21,259	2,400	23,031	2,600	37,770	4,264
K714_1250 MT20	125.4	320943/2560	2,900	2,600	3,800	10/6	1.9	713	80.5	12,970	1,464	12,970	1,464	16,213	1,830
K714_1270 MT30	127.0	520149/4096	2,900	2,600	3,800	10/6	7.0	715	80.8	21,259	2,400	23,031	2,600	41,817	4,721
K714_1370 MT20	137.0	5481/40	2,900	2,600	3,800	10/6	1.8	714	80.6	13,615	1,537	13,615	1,537	17,018	1,921
K714_1390 MT30	138.8	8883/64	2,900	2,600	3,800	10/6	6.9	716	80.8	21,259	2,400	23,031	2,600	42,518	4,800
K714_1520 MT20	151.7	24273/160	2,900	2,600	3,800	10/6	1.8	715	80.7	15,073	1,702	15,073	1,702	18,842	2,127
K714_1540 MT30	153.7	39339/256	2,900	2,600	3,800	10/6	6.8	716	80.9	21,259	2,400	23,031	2,600	42,518	4,800
K714_1740 MT20	174.2	72471/416	2,900	2,600	3,800	10/6	1.6	716	80.8	16,434	1,855	16,434	1,855	20,542	2,319
K714_1760 MT30	176.5	587265/3328	2,900	2,600	3,800	10/6	6.7	717	80.9	21,259	2,400	23,031	2,600	42,518	4,800
K714_1930 MT20	192.9	320943/1664	2,900	2,600	3,800	10/6	1.6	716	80.9	18,194	2,054	18,194	2,054	22,743	2,567
K714_1950 MT30	195.4	2600745/13312	2,900	2,600	3,800	10/6	6.7	717	81.0	21,259	2,400	23,031	2,600	42,518	4,800
K714_2260 MT20	226.5	72471/320	2,900	2,600	3,800	10/6	1.5	717	81.0	17,798	2,009	20,216	2,282	25,271	2,853
K714_2290 MT30	229.4	117453/512	2,900	2,600	3,800	10/6	6.6	718	81.0	21,259	2,400	23,031	2,600	42,518	4,800
K714_2510 MT20	250.7	320943/1280	2,900	2,600	3,800	10/6	1.5	717	81.0	19,705	2,225	22,382	2,527	27,978	3,159
K714_2540 MT30	254.0	520149/2048	2,900	2,600	3,800	10/6	6.6	718	81.1	21,259	2,400	23,031	2,600	42,518	4,800
K714_2750 MT20	275.3	44051/160	2,900	2,600	3,800	10/6	1.5	718	81.0	18,362	2,073	23,031	2,600	29,352	3,314

Index of Symbols: **MT** — Motor adapter with TriAdapt® coupling; **MQ** — Square Motor adapter

See Page 238 for Options and Part Number Configuration.





"K" Series—Right Angle Helical/Bevel ServoFit® Modular System Selection Data



Part Number	Reducer Ratio i		Input RPM			Backlash arcmins $\Delta\phi$ ¹⁾	Input Inertia J ₁ kgcm ²	Torsional Stiffness per arcmin C ₂		Output Torque					
			Maximum							Nominal ²⁾		Acceleration		Peak ³⁾	
	Nom.		Exact		Continuous			Cyclic	M _{2N} ≤ 2000 RPM		M _{ZB}		M _{2PEAK}		
	n _{1DBH}	n _{1DBV}	n _{1ZB}		in.lbs.			Nm	in.lbs.	Nm	in.lbs.	Nm	in.lbs.	Nm	
K714 with MT TriAdapt® Motor Adapter Continued										Noise Level ≤ 59 dB(A) ⁴⁾					
K714_3050 MT20	304.8	195083/640	2,900	2,600	3,800	10/6	1.5	718	81.0	20,330	2,295	23,031	2,600	32,497	3,669
K714_3440 MT20	344.1	44051/128	2,900	2,600	3,800	10/6	1.4	718	81.1	14,803	1,671	17,764	2,005	29,607	3,342
K714_3810 MT20	381.0	195083/512	2,900	2,600	3,800	10/6	1.4	718	81.1	16,394	1,851	19,672	2,221	32,787	3,701
K813 with MT TriAdapt® Motor Adapter Continued Next Page										Noise Level ≤ 65 dB(A) ⁴⁾					
K813_0074 MT30	7.445	3127/420	1,600	1,500	2,600	10/5	161.2	350	39.5	5,989	676	6,588	744	11,979	1,352
K813_0074 MT40	7.445	3127/420	1,600	1,500	2,600	10/5	165.2	564	63.7	10,163	1,147	10,163	1,147	12,704	1,434
K813_0074 MT50	7.445	3127/420	1,600	1,500	2,600	10/5	175.2	900	101.6	19,420	2,192	19,420	2,192	24,275	2,740
K813_0082 MT30	8.243	96937/11760	1,600	1,500	2,600	10/5	142.9	404	45.6	6,631	749	7,294	823	13,263	1,497
K813_0082 MT40	8.243	96937/11760	1,600	1,500	2,600	10/5	146.9	628	70.8	11,252	1,270	11,252	1,270	14,065	1,588
K813_0082 MT50	8.243	96937/11760	1,600	1,500	2,600	10/5	156.9	949	107.2	21,242	2,398	21,502	2,427	26,877	3,034
K813_0093 MT30	9.284	11977/1290	1,600	1,500	2,600	10/5	115.5	471	53.2	7,469	843	8,216	927	14,938	1,686
K813_0093 MT40	9.284	11977/1290	1,600	1,500	2,600	10/5	119.5	702	79.2	12,266	1,385	12,266	1,385	15,333	1,731
K813_0093 MT50	9.284	11977/1290	1,600	1,500	2,600	10/5	129.5	1,001	113.0	22,101	2,495	23,439	2,646	29,299	3,308
K813_0105 MT30	10.28	53041/5160	1,600	1,500	2,600	10/5	103.7	533	60.1	8,269	934	9,096	1,027	16,539	1,867
K813_0105 MT40	10.28	53041/5160	1,600	1,500	2,600	10/5	107.7	763	86.2	13,581	1,533	13,581	1,533	16,976	1,916
K813_0105 MT50	10.28	53041/5160	1,600	1,500	2,600	10/5	117.7	1,039	117.3	22,864	2,581	25,951	2,930	32,439	3,662
K813_0120 MT30	11.91	6608/555	1,900	1,800	2,900	10/5	80.6	624	70.4	9,578	1,081	10,536	1,189	18,938	2,138
K813_0120 MT40	11.91	6608/555	1,900	1,800	2,900	10/5	84.6	848	95.7	15,150	1,710	15,150	1,710	18,938	2,138
K813_0120 MT50	11.91	6608/555	1,900	1,800	2,900	10/5	94.6	1,086	122.6	24,011	2,711	28,950	3,268	36,188	4,085
K813_0130 MT30	13.18	7316/555	1,900	1,800	2,900	10/5	73.4	687	77.6	10,605	1,197	11,665	1,317	20,967	2,367
K813_0130 MT40	13.18	7316/555	1,900	1,800	2,900	10/5	77.4	901	101.8	16,774	1,894	16,774	1,894	20,967	2,367
K813_0130 MT50	13.18	7316/555	1,900	1,800	2,900	10/5	87.4	1,113	125.7	24,840	2,804	32,053	3,619	40,066	4,523
K813_0150 MT30	14.84	9499/640	1,900	1,800	2,900	10/5	59.2	760	85.8	11,940	1,348	13,134	1,483	22,766	2,570
K813_0150 MT40	14.84	9499/640	1,900	1,800	2,900	10/5	63.2	958	108.2	18,213	2,056	18,213	2,056	22,766	2,570
K813_0150 MT50	14.84	9499/640	1,900	1,800	2,900	10/5	73.2	1,140	128.7	25,842	2,917	34,803	3,929	43,504	4,911
K813_0165 MT30	16.43	42067/2560	1,900	1,800	2,900	10/5	54.5	819	92.5	13,219	1,492	14,541	1,642	25,205	2,845
K813_0165 MT40	16.43	42067/2560	1,900	1,800	2,900	10/5	58.5	1,001	113.1	20,164	2,276	20,164	2,276	25,205	2,845
K813_0165 MT50	16.43	42067/2560	1,900	1,800	2,900	10/5	68.5	1,159	130.9	26,734	3,018	38,531	4,350	48,164	5,437
K813_0175 MT30	17.33	30149/1740	2,300	2,100	3,300	10/5	48.4	849	95.8	13,939	1,574	15,333	1,731	25,932	2,928
K813_0175 MT40	17.33	30149/1740	2,300	2,100	3,300	10/5	52.4	1,022	115.4	20,746	2,342	20,746	2,342	25,932	2,928
K813_0175 MT50	17.33	30149/1740	2,300	2,100	3,300	10/5	62.4	1,168	131.8	27,211	3,072	39,642	4,475	49,553	5,594
K813_0190 MT30	19.18	133517/6960	2,300	2,100	3,300	10/5	45.1	902	101.8	15,432	1,742	16,976	1,916	28,710	3,241
K813_0190 MT40	19.18	133517/6960	2,300	2,100	3,300	10/5	49.1	1,058	119.4	22,968	2,593	22,968	2,593	28,710	3,241
K813_0190 MT50	19.18	133517/6960	2,300	2,100	3,300	10/5	59.1	1,183	133.5	28,149	3,178	41,190	4,650	54,861	6,193
K813_0230 MT30	23.04	31801/1380	2,300	2,100	3,300	10/5	33.8	987	111.4	18,539	2,093	20,392	2,302	32,546	3,674
K813_0230 MT40	23.04	31801/1380	2,300	2,100	3,300	10/5	37.8	1,111	125.4	26,037	2,939	26,037	2,939	32,546	3,674
K813_0230 MT50	23.04	31801/1380	2,300	2,100	3,300	10/5	47.8	1,203	135.8	29,924	3,378	41,190	4,650	62,192	7,021
K813_0260 MT30	25.51	140833/5520	2,300	2,100	3,300	10/5	31.9	1,027	115.9	20,525	2,317	22,577	2,549	36,033	4,068
K813_0260 MT40	25.51	140833/5520	2,300	2,100	3,300	10/5	35.9	1,134	128.1	28,827	3,254	28,827	3,254	36,033	4,068
K813_0260 MT50	25.51	140833/5520	2,300	2,100	3,300	10/5	45.9	1,212	136.8	30,956	3,495	41,190	4,650	68,856	7,773
K813_0290 MT30	29.25	7021/240	2,800	2,500	3,600	10/5	24.9	1,073	121.2	20,833	2,352	25,888	2,923	39,618	4,473
K813_0290 MT40	29.25	7021/240	2,800	2,500	3,500	10/5	28.9	1,161	131.0	31,694	3,578	31,694	3,578	39,618	4,473
K813_0290 MT50	29.25	7021/240	2,500	2,500	3,000	10/5	38.9	1,221	137.9	32,401	3,658	41,190	4,650	74,407	8,400
K813_0320 MT30	32.39	31093/960	2,800	2,500	3,600	10/5	23.7	1,102	124.4	23,065	2,604	28,662	3,236	43,863	4,952
K813_0320 MT40	32.39	31093/960	2,800	2,500	3,500	10/5	27.7	1,176	132.8	33,519	3,784	35,091	3,961	43,863	4,952
K813_0320 MT50	32.39	31093/960	2,500	2,500	3,000	10/5	37.7	1,227	138.5	33,519	3,784	41,190	4,650	74,407	8,400

¹⁾ Backlash shown "STANDARD/REDUCED".

²⁾ Maximum torque for continuous input RPM - horizontal output position.

³⁾ Maximum momentary torque for emergency stops or heavy shock load. Admissible stops per life of reducer = 1,000 stops maximum.

⁴⁾ dB(A) Measured at 1 meter distance with 3000 RPM input

Maximum Motor Shaft

Adapter	Diameter	Adapter	Diameter	Adapter	Diameter
KL1_MQ	16	MT10	19	MT40	48
KL2_MQ	19	MT20	24	MT50	60
		MT30	38		



"K" Series—Right Angle Helical/Bevel ServoFit® Modular System Selection Data



Part Number	Reducer Ratio i		Input RPM			Backlash arcmin $\Delta\phi$ ¹⁾	Input Inertia J ₁ kgcm ²	Torsional Stiffness per arcmin C ₂		Output Torque					
			Maximum							Nominal ²⁾		Acceleration		Peak ³⁾	
	Nom.	Exact	n _{1DBH}	n _{1DBV}	n _{1ZB}			M _{2N ≤ 2000 RPM}		M _{2B}		M _{2PEAK}			
								in.lbs.	Nm	in.lbs.	Nm	in.lbs.	Nm		
K813 with MT TriAdapt® Motor Adapter Continued							Noise Level ≤ 65 dB(A) ⁴⁾								
K813_0360 MT30	36.14	2891/80	2,800	2,500	3,600	10/5	19.4	1,129	127.4	21,177	2,391	31,980	3,610	46,613	5,262
K813_0360 MT40	36.14	2891/80	2,800	2,500	3,500	10/5	23.4	1,191	134.4	34,766	3,925	37,290	4,210	46,613	5,262
K813_0360 MT50	36.14	2891/80	2,500	2,500	3,000	10/5	33.4	1,232	139.1	34,766	3,925	41,190	4,650	74,407	8,400
K813_0400 MT30	40.01	12803/320	2,800	2,500	3,600	10/5	18.6	1,150	129.8	23,446	2,647	35,405	3,997	51,606	5,826
K813_0400 MT40	40.01	12803/320	2,800	2,500	3,500	10/5	22.6	1,201	135.6	35,965	4,060	41,190	4,650	51,606	5,826
K813_0400 MT50	40.01	12803/320	2,500	2,500	3,000	10/5	32.6	1,236	139.5	35,965	4,060	41,190	4,650	74,407	8,400
K813_0440 MT30	44.25	177/4	2,800	2,500	3,600	10/5	15.5	1,167	131.8	22,059	2,490	39,158	4,421	54,814	6,188
K813_0440 MT40	44.25	177/4	2,800	2,500	3,500	10/5	19.5	1,210	136.6	37,194	4,199	41,190	4,650	54,814	6,188
K813_0440 MT50	44.25	177/4	2,500	2,500	3,000	10/5	29.5	1,239	139.8	37,194	4,199	41,190	4,650	54,814	6,188
K813_0490 MT30	48.99	5487/112	2,800	2,500	3,600	10/5	15.0	1,182	133.4	24,422	2,757	41,190	4,650	60,687	6,851
K813_0490 MT40	48.99	5487/112	2,800	2,500	3,500	10/5	19.0	1,218	137.5	37,204	4,200	41,190	4,650	60,687	6,851
K813_0490 MT50	48.99	5487/112	2,500	2,500	3,000	10/5	29.0	1,241	140.1	37,204	4,200	41,190	4,650	60,687	6,851
K813_0590 MT30	59.08	42539/720	2,800	2,500	3,600	10/5	11.8	1,203	135.8	22,721	2,565	41,190	4,650	68,590	7,743
K813_0590 MT40	59.08	42539/720	2,800	2,500	3,500	10/5	15.8	1,228	138.7	37,204	4,200	41,190	4,650	68,590	7,743
K813_0590 MT50	59.08	42539/720	2,500	2,500	3,000	10/5	25.8	1,245	140.5	37,204	4,200	41,190	4,650	68,590	7,743
K813_0650 MT30	65.41	188387/2880	2,800	2,500	3,600	10/5	11.5	1,212	136.8	25,155	2,840	41,190	4,650	74,407	8,400
K813_0650 MT40	65.41	188387/2880	2,800	2,500	3,500	10/5	15.5	1,233	139.2	37,204	4,200	41,190	4,650	74,407	8,400
K813_0650 MT50	65.41	188387/2880	2,500	2,500	3,000	10/5	25.5	1,246	140.7	37,204	4,200	41,190	4,650	74,407	8,400
K813_0720 MT30	71.70	10325/144	2,800	2,500	3,600	10/5	10.1	1,218	137.5	23,288	2,629	38,322	4,326	63,869	7,210
K813_0720 MT40	71.70	10325/144	2,800	2,500	3,500	10/5	14.1	1,236	139.5	31,935	3,605	38,322	4,326	63,869	7,210
K813_0720 MT50	71.70	10325/144	2,500	2,500	3,000	10/5	24.1	1,247	140.8	31,935	3,605	38,322	4,326	63,869	7,210
K813_0790 MT30	79.38	45725/576	2,800	2,500	3,600	10/5	9.9	1,225	138.2	25,783	2,911	41,190	4,650	70,731	7,985
K813_0790 MT40	79.38	45725/576	2,800	2,500	3,500	10/5	13.9	1,239	139.9	35,365	3,992	41,190	4,650	70,731	7,985
K813_0790 MT50	79.38	45725/576	2,500	2,500	3,000	10/5	23.9	1,248	140.9	35,365	3,992	41,190	4,650	70,731	7,985
K813_0880 MT30	87.76	7021/80	2,800	2,500	3,600	10/5	8.8	1,229	138.8	23,753	2,682	28,945	3,268	36,182	4,085
K813_0880 MT40	87.76	7021/80	2,800	2,500	3,500	10/5	12.8	1,241	140.1	24,838	2,804	28,945	3,268	36,182	4,085
K813_0970 MT30	97.17	31093/320	2,800	2,500	3,600	10/5	8.7	1,234	139.3	26,298	2,969	32,047	3,618	40,058	4,522
K813_0970 MT40	97.17	31093/320	2,800	2,500	3,500	10/5	12.7	1,243	140.4	27,506	3,105	32,047	3,618	40,058	4,522
K814 with MT TriAdapt® Motor Adapter Continued Next Page							Noise Level ≤ 65 dB(A) ⁴⁾								
K814_0670 MT40	66.83	38763/580	2,800	2,500	3,500	10/6	14.5	1,234	139.3	37,204	4,200	39,644	4,476	49,555	5,594
K814_0740 MT40	73.99	1201653/16240	2,800	2,500	3,500	10/6	14.3	1,237	139.6	37,204	4,200	41,190	4,650	54,864	6,194
K814_0890 MT40	88.89	40887/460	2,800	2,500	3,500	10/6	13.5	1,242	140.2	37,204	4,200	41,190	4,650	62,195	7,021
K814_0980 MT40	98.41	181071/1840	2,800	2,500	3,500	10/6	13.4	1,244	140.4	37,204	4,200	41,190	4,650	68,859	7,774
K814_1130 MT40	112.8	9027/80	2,800	2,500	3,500	10/6	12.9	1,246	140.6	37,204	4,200	41,190	4,650	74,407	8,400
K814_1150 MT30	114.6	329987/2880	2,800	2,500	3,600	10/6	7.7	1,239	139.8	29,076	3,282	31,692	3,578	39,615	4,472
K814_1250 MT40	124.9	279837/2240	2,800	2,500	3,500	10/6	12.8	1,247	140.8	37,204	4,200	41,190	4,650	74,407	8,400
K814_1270 MT30	126.9	1461371/11520	2,800	2,500	3,600	10/6	7.7	1,241	140.1	32,191	3,634	35,087	3,961	43,859	4,951
K814_1390 MT40	139.4	11151/80	2,800	2,500	3,500	10/6	12.5	1,248	140.9	37,204	4,200	41,190	4,650	74,407	8,400
K814_1420 MT30	141.5	135877/960	2,800	2,500	3,600	10/6	7.4	1,243	140.4	30,138	3,402	37,287	4,209	46,608	5,262
K814_1540 MT40	154.3	49383/320	2,800	2,500	3,500	10/6	12.5	1,249	141.0	37,204	4,200	41,190	4,650	74,407	8,400
K814_1570 MT30	156.7	601741/3840	2,800	2,500	3,600	10/6	7.3	1,245	140.6	33,367	3,767	41,190	4,650	51,602	5,825
K814_1710 MT40	170.7	4779/28	2,800	2,500	3,500	10/6	12.3	1,249	141.0	37,204	4,200	41,190	4,650	54,816	6,188
K814_1730 MT30	173.3	2773/16	2,800	2,500	3,600	10/6	7.1	1,246	140.7	31,904	3,602	41,190	4,650	54,810	6,188
K814_1890 MT40	189.0	148149/784	2,800	2,500	3,500	10/6	12.2	1,250	141.1	37,204	4,200	41,190	4,650	60,690	6,851

Index of Symbols: **MT** — Motor adapter with TriAdapt® coupling; **MQ** — Square Motor adapter

See Page 238 for Options and Part Number Configuration.





"K" Series—Right Angle Helical/Bevel ServoFit® Modular System Selection Data



Part Number	Reducer Ratio i		Input RPM			Backlash arcmins $\Delta\phi$ ¹⁾	Input Inertia J ₁ kgcm ²	Torsional Stiffness per arcmin C ₂		Output Torque					
			Maximum							Nominal ²⁾		Acceleration		Peak ³⁾	
	Continuous			M _{2N} ≤ 2000 RPM				M _{2B}		M _{2PEAK}					
	η _{1DBH}	η _{1DBV}	η _{1ZB}	in.lbs.	Nm			in.lbs.	Nm	in.lbs.	Nm	in.lbs.	Nm		
K814 with MT TriAdapt® Motor Adapter <i>Continued</i>										Noise Level ≤ 65 dB(A) ⁴⁾					
K814_1920 MT30	191.9	85963/448	2,800	2,500	3,600	10/6	7.1	1,247	140.8	35,323	3,988	41,190	4,650	60,682	6,851
K814_2280 MT40	227.9	18231/80	2,800	2,500	3,500	10/6	12.0	1,251	141.2	37,204	4,200	41,190	4,650	68,593	7,744
K814_2310 MT30	231.4	1999333/8640	2,800	2,500	3,600	10/6	6.9	1,249	141.0	33,726	3,807	41,190	4,650	68,584	7,743
K814_2520 MT40	252.3	565161/2240	2,800	2,500	3,500	10/6	12.0	1,251	141.2	37,204	4,200	41,190	4,650	74,407	8,400
K814_2560 MT30	256.2	8854189/34560	2,800	2,500	3,600	10/6	6.9	1,250	141.1	37,204	4,200	41,190	4,650	74,407	8,400
K814_2770 MT40	276.6	4425/16	2,800	2,500	3,500	10/6	11.9	1,251	141.2	31,935	3,605	38,322	4,326	63,869	7,210
K814_2810 MT30	280.8	485275/1728	2,800	2,500	3,600	10/6	6.8	1,250	141.1	31,935	3,605	38,322	4,326	63,869	7,210
K814_3060 MT40	306.2	137175/448	2,800	2,500	3,500	10/6	11.9	1,251	141.3	35,365	3,992	41,190	4,650	70,731	7,985
K814_3110 MT30	310.9	2149075/6912	2,800	2,500	3,600	10/6	6.8	1,250	141.2	35,365	3,992	41,190	4,650	70,731	7,985
K913 with MT TriAdapt® Motor Adapter										Noise Level ≤ 65 dB(A) ⁴⁾					
K913_0079 MT50	7.934	54839/6912	1,500	1,500	2,500	10/5	351.2	1,232	139.1	21,757	2,456	21,757	2,456	27,197	3,070
K913_0100 MT50	10.12	119133/11776	1,500	1,500	2,500	10/5	248.9	1,417	159.9	26,753	3,020	26,753	3,020	33,441	3,775
K913_0125 MT50	12.53	73749/5888	1,800	1,800	2,800	10/5	186.8	1,545	174.4	32,159	3,631	32,159	3,631	40,199	4,538
K913_0160 MT50	15.91	13237/832	1,800	1,800	2,800	10/5	135.0	1,652	186.5	39,199	4,425	39,199	4,425	48,999	5,532
K913_0190 MT50	19.06	305/16	2,200	2,100	3,000	10/5	108.9	1,711	193.2	45,504	5,137	45,504	5,137	56,880	6,421
K913_0240 MT40	23.94	88877/3712	2,200	2,100	3,100	10/5	73.0	1,585	178.9	28,667	3,236	28,667	3,236	35,834	4,045
K913_0240 MT50	23.94	88877/3712	2,200	2,100	3,000	10/5	83.0	1,764	199.1	54,779	6,184	54,779	6,184	68,474	7,730
K913_0320 MT40	32.12	47275/1472	2,600	2,500	3,400	10/5	50.5	1,697	191.6	36,287	4,097	36,287	4,097	45,359	5,121
K913_0320 MT50	32.12	47275/1472	2,500	2,500	3,000	10/5	60.5	1,806	203.9	60,669	6,849	68,207	7,700	86,676	9,785
K913_0380 MT40	38.04	194773/5120	2,600	2,500	3,400	10/5	40.9	1,742	196.6	41,507	4,686	41,507	4,686	51,884	5,857
K913_0380 MT50	38.04	194773/5120	2,500	2,500	3,000	10/5	50.9	1,822	205.7	62,006	7,000	68,207	7,700	99,144	11,193
K913_0490 MT40	48.94	100223/2048	2,600	2,500	3,400	10/5	30.6	1,788	201.8	50,266	5,675	50,497	5,701	63,122	7,126
K913_0490 MT50	48.94	100223/2048	2,500	2,500	3,000	10/5	40.6	1,838	207.5	62,006	7,000	68,207	7,700	120,618	13,617
K913_0630 MT40	63.07	209901/3328	2,600	2,500	3,400	10/5	23.5	1,817	205.1	51,864	5,855	61,561	6,950	76,952	8,687
K913_0630 MT50	63.07	209901/3328	2,500	2,500	3,000	10/5	33.5	1,848	208.6	62,006	7,000	68,207	7,700	124,012	14,000
K913_0750 MT40	75.00	62403/832	2,600	2,500	3,400	10/5	19.9	1,830	206.6	53,248	6,011	68,207	7,700	88,210	9,958
K913_0750 MT50	75.00	62403/832	2,500	2,500	3,000	10/5	29.9	1,852	209.1	62,006	7,000	68,207	7,700	88,210	9,958
K913_0950 MT40	95.41	293105/3072	2,600	2,500	3,400	10/5	16.4	1,843	208.0	47,620	5,376	57,144	6,451	95,240	10,752
K913_0950 MT50	95.41	293105/3072	2,500	2,500	3,000	10/5	26.4	1,856	209.6	47,620	5,376	57,144	6,451	95,240	10,752
K914 with MT TriAdapt® Motor Adapter										Noise Level ≤ 65 dB(A) ⁴⁾					
K914_0920 MT40	92.35	2399679/25984	2,600	2,500	3,400	10/5	15.9	1,841	207.9	54,781	6,184	54,781	6,184	68,477	7,730
K914_0940 MT30	93.78	4177219/44544	2,600	2,500	3,400	10/5	10.6	1,819	205.3	25,351	2,862	28,664	3,236	35,831	4,045
K914_1240 MT40	123.9	1276425/10304	2,600	2,500	3,400	10/5	14.3	1,851	208.9	60,960	6,882	68,207	7,700	86,680	9,785
K914_1260 MT30	125.8	2221925/17664	2,600	2,500	3,400	10/5	9.1	1,838	207.5	34,011	3,840	36,284	4,096	45,355	5,120
K914_1470 MT40	146.7	5258871/35840	2,600	2,500	3,400	10/5	13.7	1,854	209.3	62,006	7,000	68,207	7,700	99,147	11,193
K914_1490 MT30	149.0	9154331/61440	2,600	2,500	3,400	10/5	8.5	1,845	208.3	38,782	4,378	41,503	4,685	51,879	5,857
K914_1890 MT40	188.8	2706021/14336	2,600	2,500	3,400	10/5	13.0	1,858	209.7	62,006	7,000	68,207	7,700	120,623	13,617
K914_1920 MT30	191.7	4710481/24576	2,600	2,500	3,400	10/5	7.8	1,852	209.1	40,812	4,607	50,493	5,700	63,116	7,125
K914_2430 MT40	243.3	5667327/23296	2,600	2,500	3,400	10/5	12.5	1,860	210.0	62,006	7,000	68,207	7,700	124,012	14,000
K914_2470 MT30	247.0	3288449/13312	2,600	2,500	3,400	10/5	7.4	1,856	209.6	43,056	4,861	61,556	6,949	76,945	8,687
K914_2940 MT30	293.8	977647/3328	2,600	2,500	3,400	10/5	7.1	1,858	209.8	44,860	5,064	68,207	7,700	88,202	9,957
K914_3740 MT30	373.7	13775935/36864	2,600	2,500	3,400	10/5	6.9	1,860	210.0	46,783	5,281	57,144	6,451	95,240	10,752

¹⁾ Backlash shown "STANDARD/REDUCED".
²⁾ Maximum torque for continuous input RPM - horizontal output position.
³⁾ Maximum momentary torque for emergency stops or heavy shock load. Admissible stops per life of reducer = 1,000 stops maximum.
⁴⁾ dB(A) Measured at 1 meter distance with 3000 RPM input

Maximum Motor Shaft					
Adapter	Diameter	Adapter	Diameter	Adapter	Diameter
KL1_MQ	16	MT10	19	MT40	48
KL2_MQ	19	MT20	24	MT50	60
		MT30	38		



"K" Series—Right Angle Helical/Bevel ServoFit® Modular System Selection Data



Part Number	Reducer Ratio i		Input RPM			Backlash arcmins $\Delta\phi$ ¹⁾	Input Inertia J ₁ kgcm ²	Torsional Stiffness per arcmin C ₂		Output Torque					
			Maximum							Nominal ²⁾		Acceleration		Peak ³⁾	
	Nom.	Exact	n _{1DBH}	n _{1DBV}	n _{1ZB}			M _{2N} ≤ 2000 RPM		M _{2B}		M _{2PEAK}			
								in.lbs.	Nm	in.lbs.	Nm	in.lbs.	Nm		
K1013 with MT TriAdapt® Motor Adapter										Noise Level ≤ 65 dB(A) ⁴⁾					
K1013_0320 MT50	31.5	144305/4576	2,500	2,300	3,000	10/5	117.3	3,847	434.2	71,197	8,038	71,197	8,038	88,996	10,047
K1013_0390 MT50	38.6	8029/208	2,500	2,300	3,000	10/5	90.1	3,934	444.1	83,593	9,437	83,593	9,437	104,491	11,796
K1013_0490 MT50	48.5	171647/3536	2,500	2,300	3,000	10/5	68.2	4,001	451.7	100,084	11,299	100,084	11,299	125,105	14,123
K1013_0620 MT50	61.6	12803/208	2,500	2,300	3,000	10/5	52.2	4,046	456.8	105,349	11,893	116,926	13,200	150,559	16,997
K1013_0750 MT50	75.3	101773/1352	2,500	2,300	3,000	10/5	42.6	4,071	459.6	100,417	11,336	116,926	13,200	175,501	19,813
K1013_0940 MT50	94.3	235445/2496	2,500	2,300	3,000	10/5	35.1	4,090	461.7	82,844	9,352	87,608	9,890	109,510	12,363
K1014 with MT TriAdapt® Motor Adapter										Noise Level ≤ 65 dB(A) ⁴⁾					
K1014_0930 MT50	93.3	252399/2704	2,500	2,300	3,000	10/5	32.7	4,089	461.6	95,723	10,806	113,260	12,786	141,576	15,983
K1014_1220 MT40	121.6	556605/4576	2,500	2,300	3,200	10/5	18.4	4,062	458.5	70,302	7,937	71,200	8,038	89,000	10,047
K1014_1240 MT50	123.7	7359555/59488	2,500	2,300	3,000	10/5	29.3	4,104	463.3	106,296	12,000	116,926	13,200	177,477	20,036
K1014_1490 MT40	148.9	30969/208	2,500	2,300	3,200	10/5	16.5	4,082	460.8	74,065	8,361	83,596	9,437	104,495	11,797
K1014_1510 MT50	151.4	409479/2704	2,500	2,300	3,000	10/5	27.5	4,110	464.0	106,296	12,000	116,926	13,200	208,376	23,524
K1014_1870 MT40	187.2	662067/3536	2,500	2,300	3,200	10/5	15.1	4,097	462.5	78,043	8,811	100,087	11,299	125,108	14,124
K1014_1900 MT50	190.4	514941/2704	2,500	2,300	3,000	10/5	26.1	4,115	464.5	106,296	12,000	116,926	13,200	212,592	24,000
K1014_2370 MT40	237.4	49383/208	2,500	2,300	3,200	10/5	14.0	4,106	463.6	81,994	9,256	116,926	13,200	150,564	16,998
K1014_2900 MT40	290.4	392553/1352	2,500	2,300	3,200	10/5	13.3	4,112	464.2	84,369	9,525	116,926	13,200	175,508	19,813

Index of Symbols: **MT** — Motor adapter with TriAdapt® coupling; **MQ** — Square Motor adapter

See Page 238 for Options and Part Number Configuration.



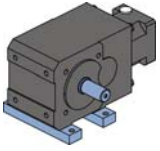

ServoFit® "KL" Series – Helical/Bevel Foot Mount – "N" Housing Shaft Output – Dimensional Data

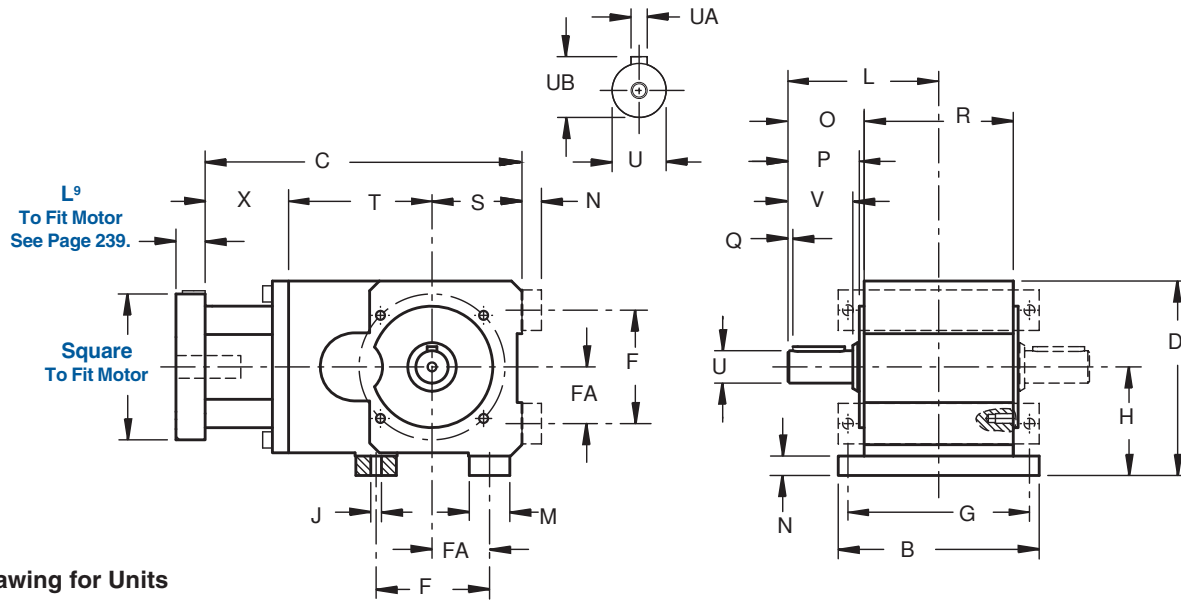

Table No. 1 "KL" Series – Foot Mounting Unit Dimensions (mm) – "N" Housing Style

Base Module	B	C	D	F	G	H	J	L	M	N	O	P	Q	R	S	T	V	X	FA
KL102PN	107	160	102	55	95	58	6.6	75.5	20	12	38	35	3	75	46	67.5	32	46.5	27.5
KL202PN	124	195	120	70	112	67	6.6	93	25	12	47	44	3	92	55	88.5	40	51.5	35

Table No. 2 Metric Output Standard on KL1.
Contact STOBER for delivery of KL2 metric or stainless output.

Base Module	Shaft — inches			Metric Shaft —mm			Stainless Shaft		Wt. lbs.
	U	UA—Key	UB	U	UA—Key	UB	Inches	mm	
KL102PN	—	—	—	16 _{k6}	M5 ×5×22	18	—	16	14
KL202PN	.750 _{k6}	³ / ₁₆ × ³ / ₁₆ × 11/4	.832	20 _{k6}	M6 ×6×32	23	.750	20	21

Part No. Example

Shaft Output, Foot Mounting
with Motor Adapter
KL202PN0080 MQ

Weight is approximate.





ServoFit® "KL" Series – Helical/Bevel Round Flange – "F" Housing Shaft Output – Dimensional Data

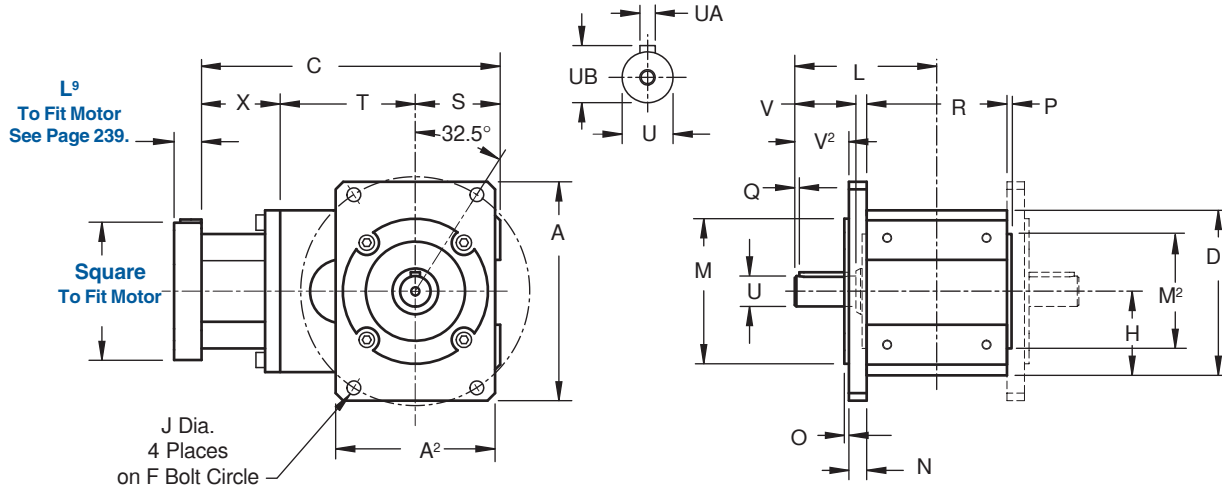
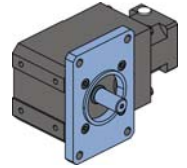

Drawing for Units
KL102PF — KL202PF

Table No. 1 "KL" Series – Round Flange Unit Dimensions (mm) – "F" Housing Style

Base Module	A	A ²	C	D	F	H	J	L	M	M ² ₁₆	N	O	P	Q	R	S	T	V	V ²	X
KL102PF	128.5	88.5	160	90	130	46	9	75.5	60	60	11.5	3	3	3	75	46	67.5	32	26.5	46.5
KL202PF	143.5	104.5	195	108	150	55	9	93	95	75	11.5	3	3	3	92	55	88.5	40	35.5	51.5

Table No. 2 Metric Output Standard on KL1.
Contact STOBER for delivery of KL2 metric or stainless output.

Base Module	Shaft — inches			Metric Shaft —mm			Stainless Shaft		Wt. lbs.
	U	UA—Key	UB	U	UA—Key	UB	Inches	mm	
KL102PF	—	—	—	16 ₁₆	M5 ×5×22	18	—	16	14
KL202PF	.750 ₁₆	³ / ₁₆ × ³ / ₁₆ × 11/4	.832	20 ₁₆	M6 ×6×32	23	.750	20	21

Part No. Example
Shaft Output, Flange Mounting
with Motor Adapter
KL202PF0080 MQ

Weight is approximate.

See Page 238 for Options and Part Number Configuration.



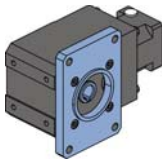

ServoFit® "KL" Series – Helical/Bevel Round Flange – "F" Housing Hollow Output – Dimensional Data

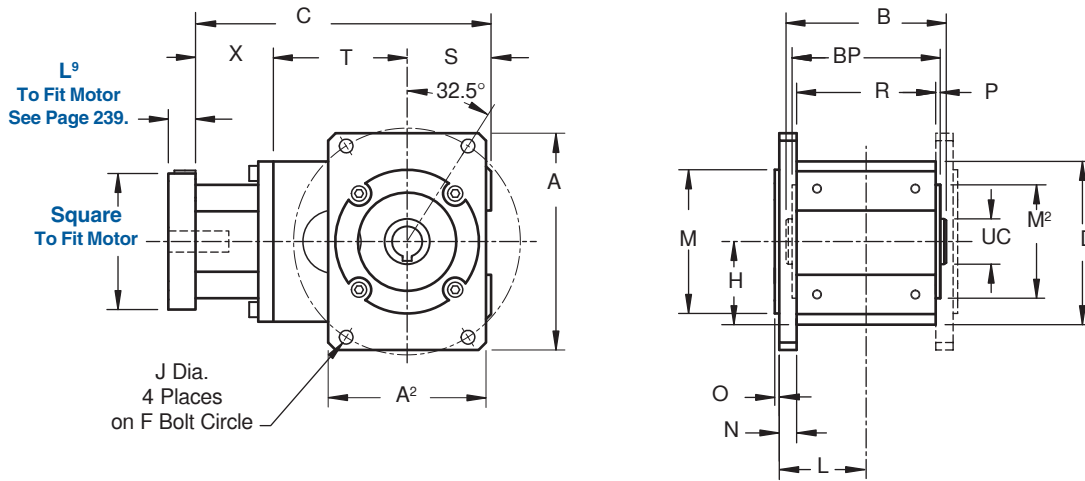

Drawing for Units
KL102AF — KL202AF

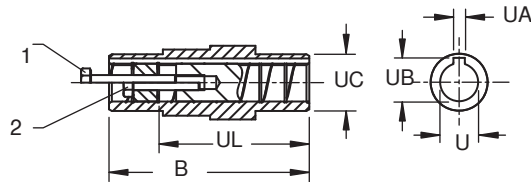

See Page 298 for installation of hollow output.

Table No. 1 "KL" Series – Round Flange Unit Dimensions (mm) – "F" Housing Style

Base Module	A	A²	B	BP	C	D	F	H	J	L	M	M ² _{j6}	N	O	P	R	S	T	X	UC	UL
KL102AF	128.5	88.5	87	81	160	90	130	46	9	49	60	60	11.5	3	3	75	46	67.5	46.5	25	60.5
KL202AF	143.5	104.5	106	98	195	108	150	55	9	57.5	95	75	11.5	3	3	92	55	88.5	51.5	30	79.5

Table No. 2 Metric Output Standard on KL1.
Contact STOBER for delivery of KL2 metric or stainless output.

Base Module	Bore - inches			Metric Bore - mm			Stainless Bore		Wt.
	U	UA	UB	U	UA	UB	Inches	mm	lbs.
KL102AF	.625 _{G7}	.188	.713	16 _{H7}	5 _{JS9}	18.3	.625	16	14
KL202AF	.750 _{G7}	.188	.832	20 _{H7}	6 _{JS9}	22.8	.750	20	21

Part No. Example

Hollow Output, Flange Mounting
with Motor Adapter
KL202AF0080 MQ

1. Removal Bolt — not supplied. See Page 298.
2. Mounting Bolt — must be smaller than removal bolt.
Weight is approximate.



ServoFit® "KL" Series – Helical/Bevel Tapped Holes – "G" Housing Hollow Output – Dimensional Data

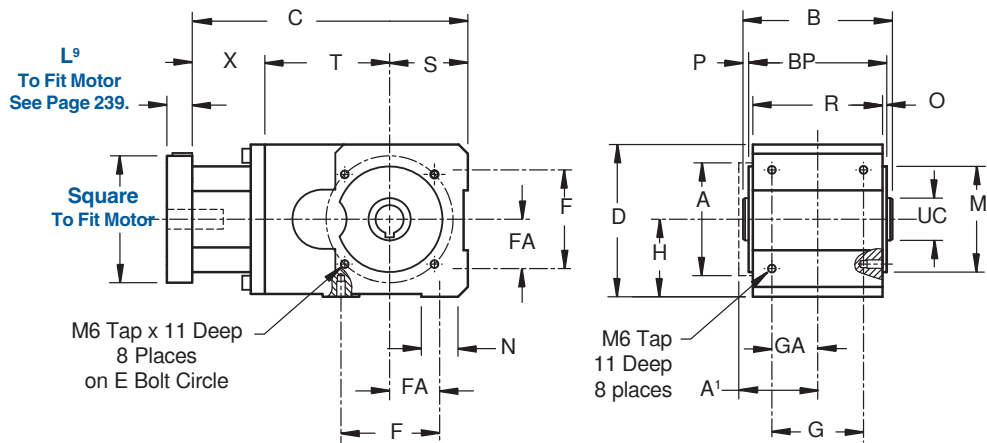
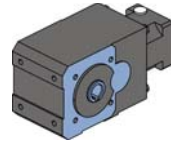

Drawing for Units
KL102AG — KL202AG

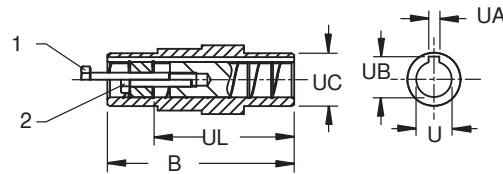

See Page 298 for installation of hollow output.

Table No. 1 "KL" Series – Tapped Hole Unit Dimensions (mm) – "G" Housing Style

Base Module	A	A'	B	C	D	E	F	G	H	M	N	O	P	R	S	T	X	BP	FA	GA	UC	UL
KL102AG	70	47.5	87	160	90	75	55	50	46	60	21	3	3	75	46	67.5	46.5	81	27.5	25	25	60.5
KL202AG	80	57	106	195	108	90	70	65	55	95	26	3	4	92	55	88.5	51.5	98	35	32.5	30	79.5

Table No. 2 Metric Output Standard on KL1.
Contact STOBER for delivery of KL2 metric or stainless output.

Base Module	Bore - inches			Metric Bore - mm			Stainless Bore		Wt. lbs.
	U	UA	UB	U	UA	UB	Inches	mm	
KL102AF	.625 _{G7}	.188	.713	16 _{H7}	5 _{JS9}	18.3	.625	16	14
KL202AF	.750 _{G7}	.188	.832	20 _{H7}	6 _{JS9}	22.8	.750	20	21

Part No. Example

Hollow Output — Tapped Holes Housing
with Square Motor Adapter
KL202AG0080 MQ

1. Removal Bolt – not supplied. See Page 298.
2. Mounting Bolt – must be smaller than removal bolt. Weight is approximate.

See Page 238 for Options and Part Number Configuration.

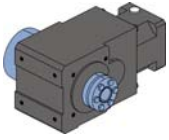

ServoFit® "KL" Series – Helical/Bevel Tapped Holes – “G” Housing Wobble Free Bushing – Dimensional Data



Drawing for Unit
KL202WG

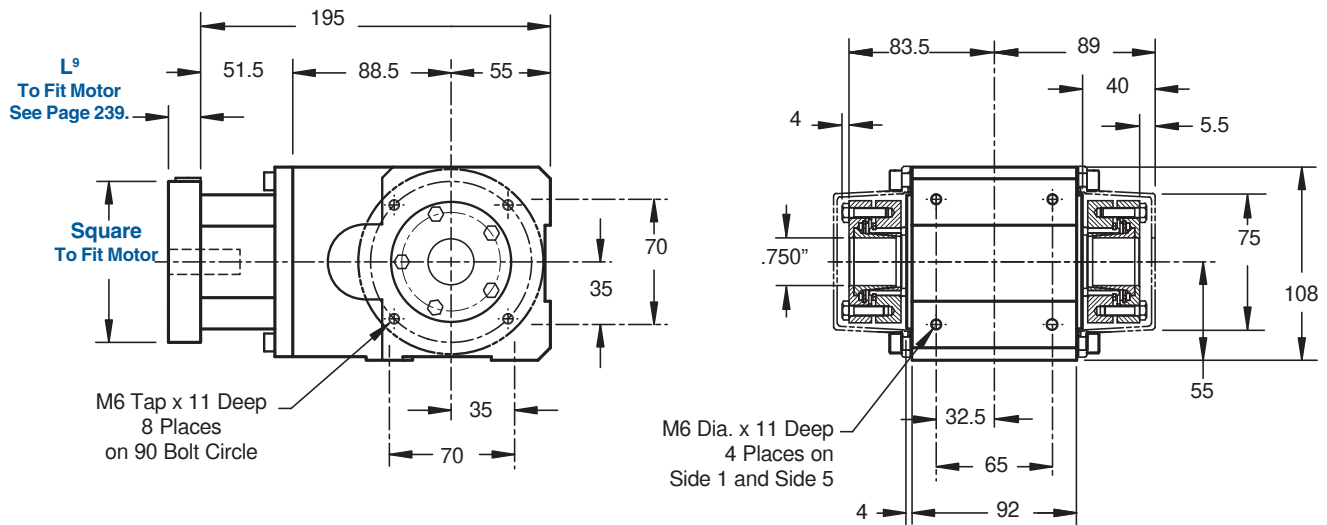

Important: A $1/32$ x 45° chamfer minimum is recommended for the shaft end.

Part No. Example

Double Wobble Free Bushing
with TriAdapt® Motor Adapter

KL202WG0080 MQ

Bushing for 3/4" Shaft

WFBKL2-012

(KL2 bushing available in .750" bore ONLY)

K

Weight is approximately 21 lbs.



ServoFit® "KL" Series – Helical/Bevel Tapped Holes – “G” Housing Shrink Ring Output – Dimensional Data

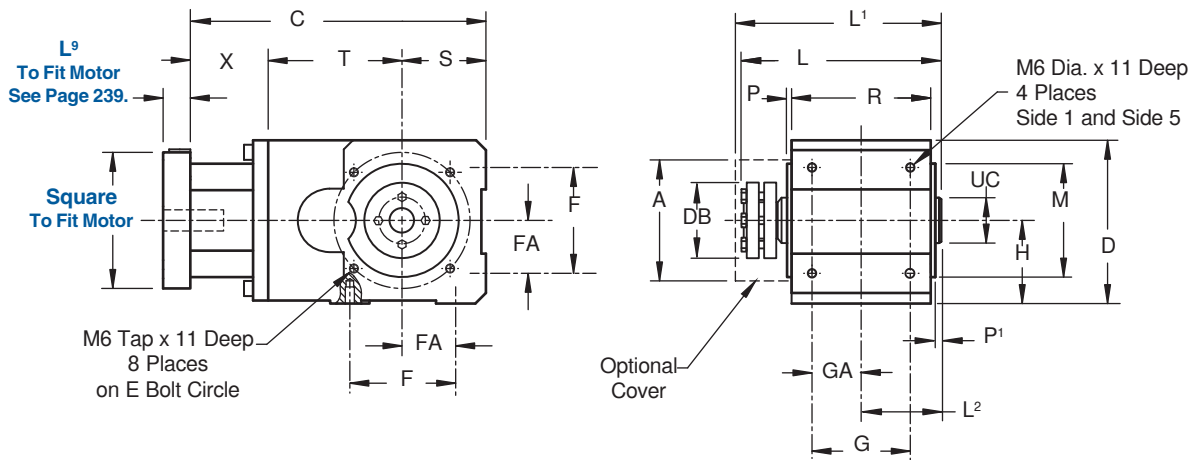
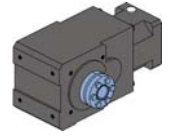

Drawing for Units
KL102SG — KL202SG

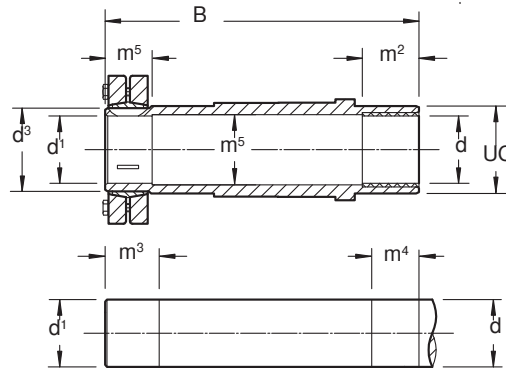

See Page 294 for shrink ring installation.

Table No. 1 "KL" Series – Single Side Shrink Ring – Unit Dimensions (mm)

Base Module	A	C	D	E	F	G	H	L	L ¹	L ²	M	P	P ¹	R	S	T	X	DB	FA	GA	UC
KL102SG	64	160	90	75	55	50	46	109	114.5	43.5	60	3	3	75	46	67.5	46.5	46.2	27.5	25	25
KL202SG	79	195	108	90	70	65	55	131	139	53	95	3	4	92	55	88.5	51.5	50	35	32.5	30

Table No.2 Bore/Shaft Dimensions (mm)

Base Module	d	Bore Shaft		d ³	d ⁴	L	m ²	m ³	m ⁴	m ⁵
		d ¹	d ²							
KL1	16 _{H7}	16 _{H7}	16 _{h6}	20	17.5	109	17	22	28	23
KL2	20 _{H7}	20 _{H7}	20 _{h6}	24	21.5	131	22	27	31	26

Important: A 1/32 x 45° chamfer minimum is recommended for the shaft end.

Part No. Example

Shrink Ring Output
with TriAdapt® Motor Adapter
KL202SG0080 MQ

Weight is approximate.

See Page 238 for Options and Part Number Configuration.



ServoFit® "K" Series – Helical/Bevel Foot Mount – "N" Housing Shaft Output – Dimensional Data

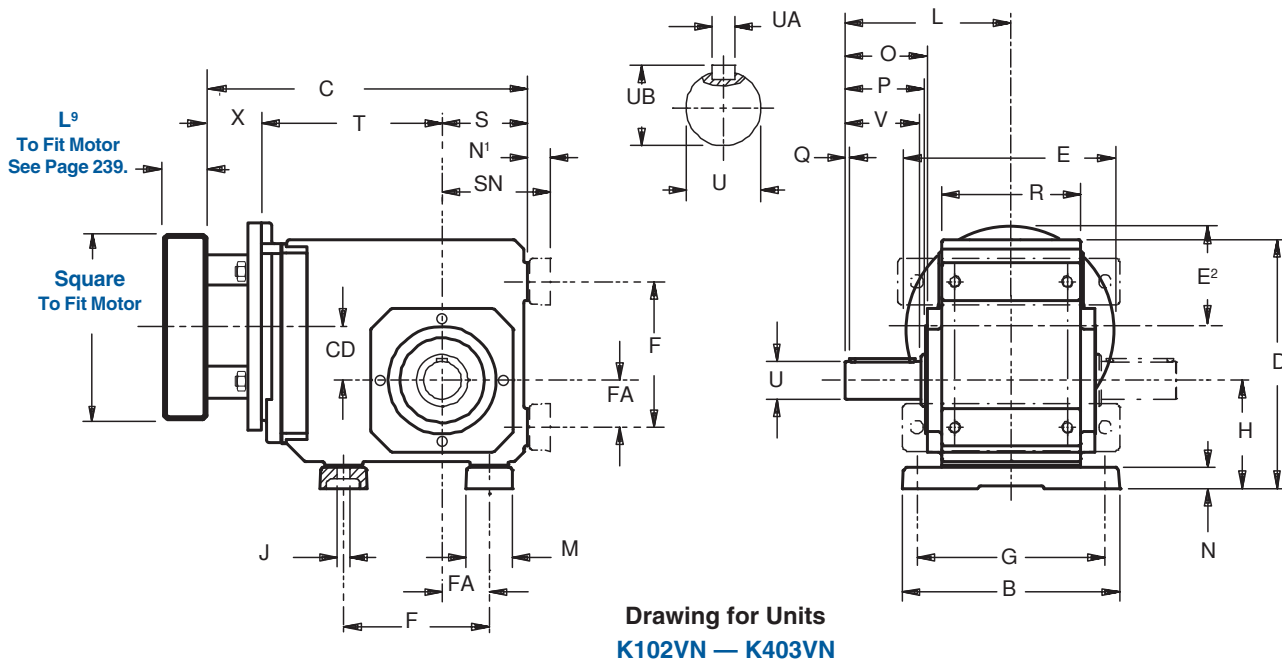

Table No. 1 "K" Series – Foot Mounting Unit Dimensions (mm) – "N" Housing Style

Base Module	B	D	F	G	H	J	L	M	N	O	P	Q	R	S	V	Z ¹	BO	FA	N ¹	SN
K102	140	175	90 ¹⁾	115	75	9	115	32	13	62	59	4	90	60	50	—	—	30	15	75
K202/203	185	213	115	155	88	11	135	40	20	68	65	4	115	65	60	—	—	35	23	88
K302/303	200	236	130	170	98	11	142	45	20	69	66	4	130	75	60	—	—	40	23	98
K402/403	230	265	155	200	115	14	176	50	22	89.5	86	4	148	90	80	—	—	50	25	115
K513/514	240	290	140	200	190	18	222	60	27	129.5	126	4	160	100	90	342	185	40	30	130
K613/614	250	340	160	210	220	18.5	236	65	27	136	109.5	4	168	120	100	392	200	50	30	150
K713/714	290	380	180	241	250	23	277	70	35	164	130.5	4	190	125	120	441	226	55	38	163
K813/814	360	455	240	300	310	27	326	85	41	185	151	5	235	145	140	516	282	75	45	190
K913/914	430	545	280	360	365	34	385	95	46	220	181	8	285	180	170	615	330	95	50	230
K1013/1014	400	680	350	330	375	39	418	120	45	240	220	15	356	225	210	680	400	115	45	225

¹⁾ Mounting holes are also located on Side 1 of the K1 unit ONLY.

**Table No. 2 Metric and Stainless Output available on request.
Contact STOBER Drives for delivery.**

Base Module	Standard Shaft — inches			Metric Shaft —mm			Stainless Shaft	
	U	UA—Key	UB	U	UA—Key	UB	Inches	mm
K102	1.000 _{h6}	1/4 × 1/4 × 1 ⁹ / ₁₆	1.11	25 _{k6}	M8 ×7×40	28	1.000	25
K202/203	1.250 _{h6}	1/4 × 1/4 × 1 ¹⁵ / ₁₆	1.36	30 _{k6}	M8 ×7×50	33	1.250	30
K302/303	1.250 _{h6}	1/4 × 1/4 × 1 ¹⁵ / ₁₆	1.36	30 _{k6}	M8 ×7×50	33	1.250	40
K402/403	1.375 _{h6}	5/16 × 5/16 × 2 ⁵ / ₁₆	1.51	40 _{k6}	M12 ×8×70	43	1.375	—
K513/514	1.750 _{h6}	3/8 × 3/8 × 3 ⁵ / ₃₂	1.92	45 _{k6}	M14 ×9×80	48.5	1.750	45
K613/614	1.750 _{h6}	3/8 × 3/8 × 3 ⁵ / ₃₂	1.92	50 _{k6}	M14 ×9×90	53.5	1.750	—
K713/714	2.375 _{h6}	5/8 × 5/8 × 3 ¹⁵ / ₁₆	2.65	60 _{k6}	M18 ×11×110	64	2.375	—
K813/814	2.875 _{h6}	3/4 × 3/4 × 4 ⁵ / ₁₆	3.21	70 _{m6}	M20 ×12×125	74.5	2.875	70
K913/914	3.625 _{h6}	7/8 × 7/8 × 5 ¹ / ₂	4.01	90 _{m6}	M25 ×14×140	95	—	90
K1013/1014	4.375 _{h6}	1 × 1 × 7 ¹ / ₈	4.82	110 _{m6}	M28 ×16×180	116	—	—



K1 Housing with tapped holes on Side 1, Side 2, and Side 5. Shown EL1 with mounting feet on Side 1.

Part No. Example

Foot Mounting with TriAdapt® Motor Adapter

K303VN0650 MT20

For approximate weight, add adapter weight from Table 3 and base module weight from Table 4.



ServoFit® "K" Series – Helical/Bevel Foot Mount – "N" Housing Shaft Output – Dimensional Data

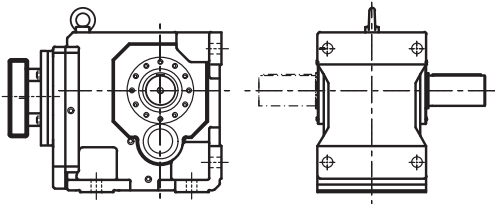
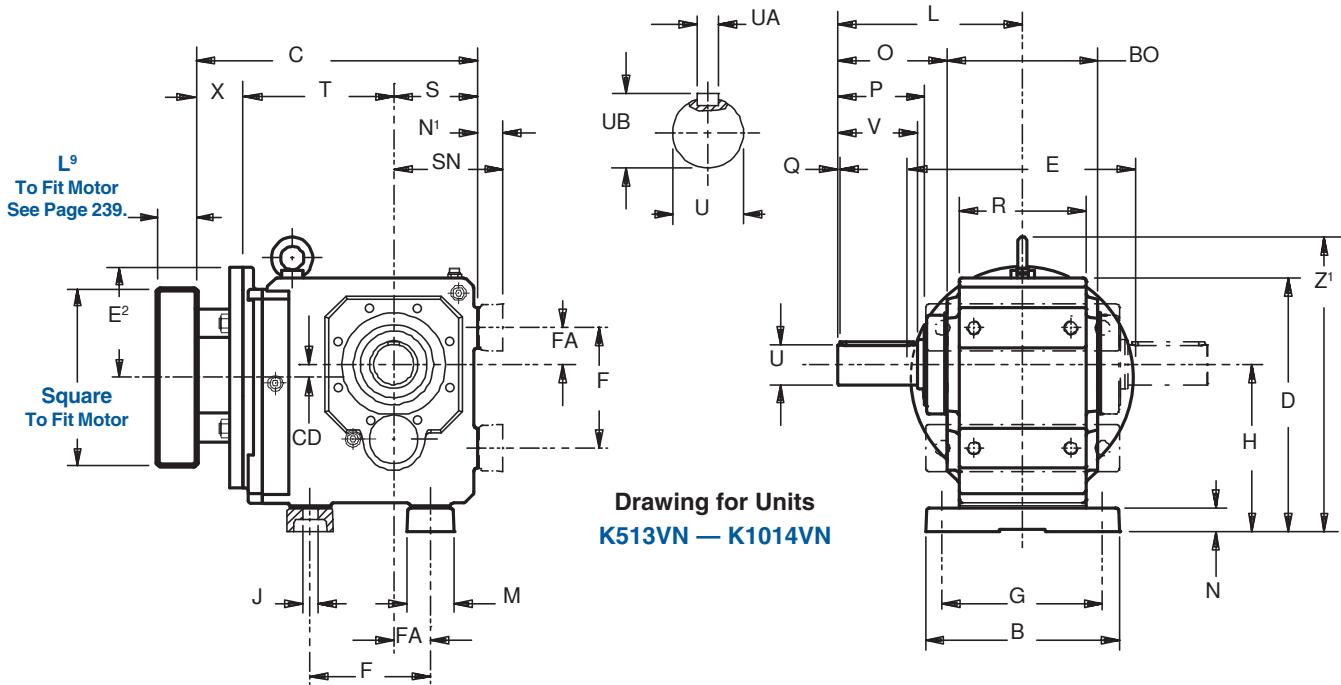

Mounting feet are integral on the K10 housing.

Table No. 3 Motor Adapter Dimensions (mm)

Motor Adapter	Motor Shaft D ⁶ Max. ¹⁾	Thickness ²⁾ L ⁹ Min.	E	E ²	X	Wt. lbs.
MT10	19	21	140	70	40	5
MT20	24	24	160	80	50	8
MT30	38	25	200	100	60	12
MT40	48	33	250	125	89	18
MT50	60	43	300	150	81.5	16

¹⁾ If an adapter bushing is required it will be supplied as a component of the motor mounting plate.
²⁾ Motor plate maximum thickness (L⁹) will vary with motor shaft length but will not be less than shown.

Table No. 4 "K" Series – Foot Mounting Unit Dimensions (mm) – "N" Housing Style

Base Module	MT10			MT20			MT30			MT40			MT50			Wt. lbs.
	CD	C	T	CD	C	T	CD	C	T	CD	C	T	CD	C	T	
K102	36	224	124	36	238	128	—	—	—	—	—	—	—	—	—	31
K202	46	248	143	46	262	147	46	274	149	—	—	—	—	—	—	40
K203	46	285	180	—	—	—	—	—	—	—	—	—	—	—	—	53
K302	52.5	278	163	52.5	292	167	52.5	304	169	—	—	—	—	—	—	67
K303	52.5	315	200	16	335	210	—	—	—	—	—	—	—	—	—	73
K402	—	—	—	60	327	187	60	339	189	60	371	192	—	—	—	93
K403	60	350	220	23	370	230	—	—	—	—	—	—	—	—	—	100
K513	—	—	—	15	322	172	15	334	174	15	366	177	—	—	—	106
K514	—	—	—	15	365	215	—	—	—	—	—	—	—	—	—	109
K613	—	—	—	18	361	191	18	373	193	18	405	196	18	411.5	210	170
K614	—	—	—	18	404	234	—	—	—	—	—	—	—	—	—	177
K713	—	—	—	—	—	—	20	406	221	20	438	224	20	443.5	237	221
K714	—	—	—	20	438	263	20	468	283	—	—	—	—	—	—	234
K813	—	—	—	—	—	—	24	452	247	24	483	249	24	488.5	262	309
K814	—	—	—	—	—	—	24	513	308	5	554	320	—	—	—	331
K913	—	—	—	—	—	—	—	—	—	25	563	294	25	568.5	307	508
K914	—	—	—	—	—	—	25	593	353	25	634	365	—	—	—	530
K1013	—	—	—	—	—	—	—	—	—	—	—	—	28	698.5	392	1,055
K1014	—	—	—	—	—	—	—	—	—	28	764	450	28	781.5	475	1,079

See Page 238 for Options and Part Number Configuration.

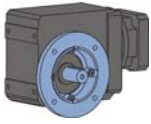

ServoFit® "K" Series – Helical/Bevel Round Flange – "F" Housing Shaft Output – Dimensional Data

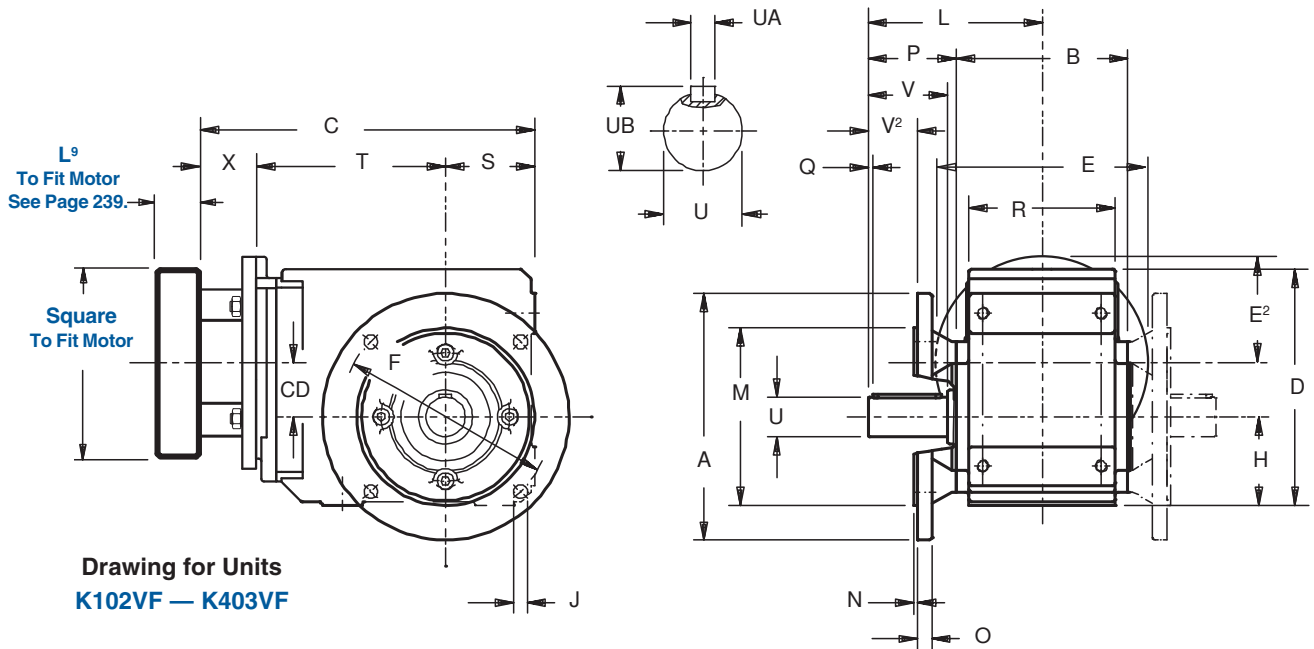

Table No. 1 "K" Series – Round Flange Unit Dimensions (mm) – "F" Housing Style

Base Module	A	B	D	F	H	J	L	M	N	O	P	Q	R	S	V	V ²	Z ¹
K102	160	106	160	130	60	9	115	110 _{js}	3.5	10	62	4	90	60	50	30	—
K202/203	200	134	190	165	65	11	135	130 _{js}	3.5	12	68	4	115	65	60	36	—
K302/303	200	146	213	165	75	11	142	130 _{js}	3.5	14	69	4	130	75	60	31	—
K402/403	250	173	240	215	90	14	176	180 _{js}	4	15	89.5	4	148	90	80	49.5	—
K513/514	250	185	260	215	160	14	222	180 _{js}	4	15	129.5	4	160	100	90	—	312
K613/614	300	200	310	265	190	14	236	230 _{js}	4	17	136	4	168	120	100	—	362
K713/714	350	226	342	300	212	18	277	250 _{hs}	5	18	164	4	190	125	120	—	403
K813/814	400	282	410	350	265	18	326	300 _{hs}	5	20	195	5	235	145	140	—	471
K913/914	450	330	495	400*	315	18	385	350 _{hs}	5	23	220	8	285	180	170	—	565
K1013/K1014	550	400	591	500*	375	18	418	450 _{hs}	5	25	210	15	356	225	210	—	680

* K913 thru K1014 has 8 mounting holes in the output flange instead of 4 as shown in drawing.

**Table No. 2 Metric and Stainless Output available on request.
Contact STOBER Drives for delivery.**

Base Module	Standard Shaft — inches			Metric Shaft —mm			Stainless Shaft	
	U	UA—Key	UB	U	UA—Key	UB	Inches	mm
K102	1.000 _{hs}	1/4 × 1/4 × 1 ⁹ / ₁₆	1.11	25 _{ks}	M8 × 7×40	28	1.000	25
K202/203	1.250 _{hs}	1/4 × 1/4 × 1 ¹⁵ / ₁₆	1.36	30 _{ks}	M8 × 7×50	33	1.250	30
K302/303	1.250 _{hs}	1/4 × 1/4 × 1 ¹⁵ / ₁₆	1.36	30 _{ks}	M8 × 7×50	33	1.250	40
K402/403	1.375 _{hs}	5/16 × 5/16 × 2 ⁵ / ₁₆	1.51	40 _{ks}	M12 × 8×70	43	1.375	—
K513/514	1.750 _{hs}	3/8 × 3/8 × 3 ⁵ / ₃₂	1.92	45 _{ks}	M14 × 9×80	48.5	1.750	45
K613/614	1.750 _{hs}	3/8 × 3/8 × 3 ⁵ / ₃₂	1.92	50 _{ks}	M14 × 9×90	53.5	1.750	—
K713/714	2.375 _{hs}	5/8 × 5/8 × 3 ¹⁵ / ₁₆	2.65	60 _{ks}	M18 × 11×110	64	2.375	—
K813/814	2.875 _{hs}	3/4 × 3/4 × 4 ⁵ / ₁₆	3.21	70 _{ms}	M20 × 12×125	74.5	2.875	70
K913/914	3.625 _{hs}	7/8 × 7/8 × 5 ¹ / ₂	4.01	90 _{ms}	M25 × 14×140	95	—	90
K1013/1014	4.375 _{hs}	1 × 1 × 7 ¹ / ₈	4.82	110 _{ms}	M28 × 16×180	116	—	—

Part No. Example

Round Flange with TriAdapt® Motor Adapter

K303VF0650 MT20

For approximate weight, add adapter weight from Table 3 and base module weight from Table 4.



ServoFit® "K" Series – Helical/Bevel Round Flange – "F" Housing Shaft Output – Dimensional Data

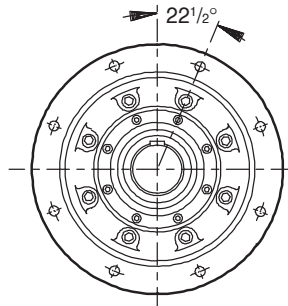
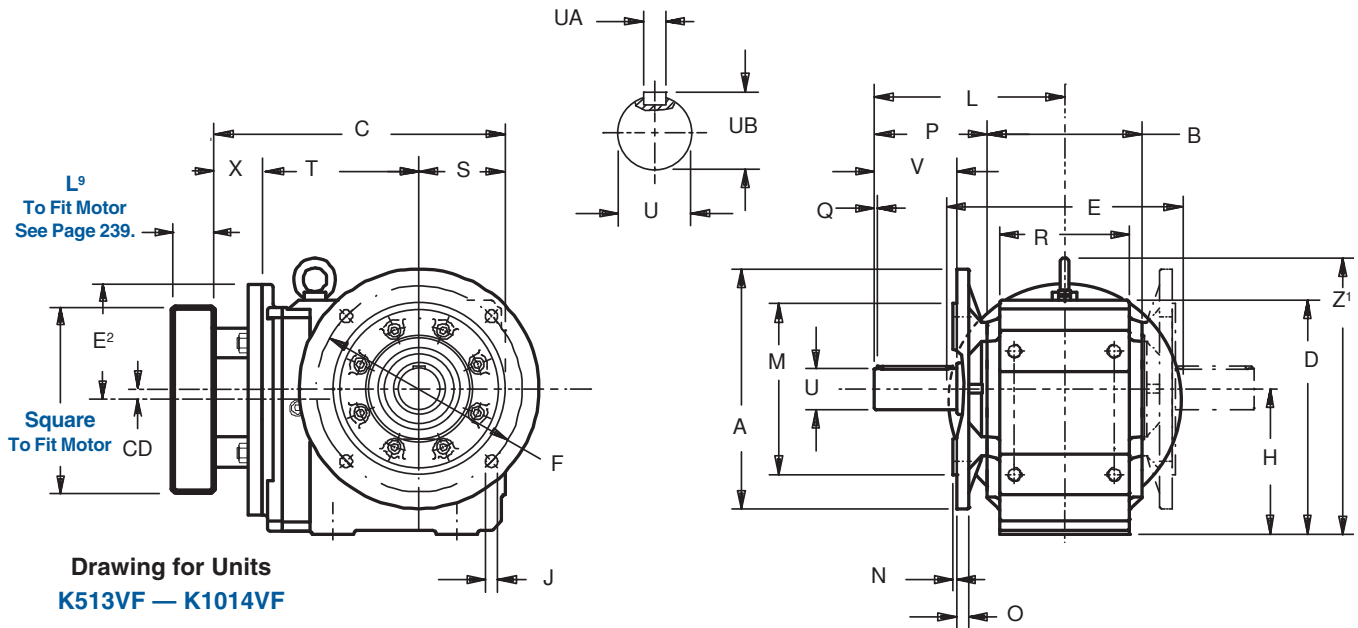

K913 thru K1014 has 8 mounting holes in the output flange located as shown.

Table No. 3 Motor Adapter Dimensions (mm)

Motor Adapter	Motor Shaft D ⁶ Max. ¹⁾	Thickness ²⁾ L ⁹ Min.	E	E ²	X	Wt. lbs.
MT10	19	21	140	70	40	5
MT20	24	24	160	80	50	8
MT30	38	25	200	100	60	12
MT40	48	33	250	125	89	18
MT50	60	43	300	150	81.5	16

¹⁾ If an adapter bushing is required it will be supplied as a component of the motor mounting plate.

²⁾ Motor plate maximum thickness (L⁹) will vary with motor shaft length but will not be less than shown.

Table No. 4 "K" Series – Flange Mounting Unit Dimensions (mm) – "F" Housing Style

Base Module	MT10			MT20			MT30			MT40			MT50			Wt. lbs.
	CD	C	T	CD	C	T	CD	C	T	CD	C	T	CD	C	T	
K102	36	224	124	36	238	128	—	—	—	—	—	—	—	—	—	31
K202	46	248	143	46	262	147	46	274	149	—	—	—	—	—	—	40
K203	46	285	180	—	—	—	—	—	—	—	—	—	—	—	—	53
K302	52.5	278	163	52.5	292	167	52.5	304	169	—	—	—	—	—	—	67
K303	52.5	315	200	16	335	210	—	—	—	—	—	—	—	—	—	73
K402	—	—	—	60	327	187	60	339	189	60	371	192	—	—	—	93
K403	60	350	220	23	370	230	—	—	—	—	—	—	—	—	—	100
K513	—	—	—	15	322	172	15	334	174	15	366	177	—	—	—	106
K514	—	—	—	15	365	215	—	—	—	—	—	—	—	—	—	109
K613	—	—	—	18	361	191	18	373	193	18	405	196	18	411.5	210	170
K614	—	—	—	18	404	234	—	—	—	—	—	—	—	—	—	177
K713	—	—	—	—	—	—	20	406	221	20	438	224	20	443.5	237	221
K714	—	—	—	20	438	263	20	468	283	—	—	—	—	—	—	234
K813	—	—	—	—	—	—	24	452	247	24	483	249	24	488.5	262	309
K814	—	—	—	—	—	—	24	513	308	5	554	320	—	—	—	331
K913	—	—	—	—	—	—	—	—	—	25	563	294	25	568.5	307	508
K914	—	—	—	—	—	—	25	593	353	25	634	365	—	—	—	530
K1013	—	—	—	—	—	—	—	—	—	—	—	—	28	698.5	392	1,055
K1014	—	—	—	—	—	—	—	—	—	28	764	450	28	781.5	475	1,079

See Page 238 for Options and Part Number Configuration.



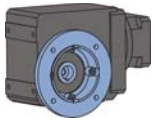

ServoFit® "K" Series – Helical/Bevel Round Flange – "F" Housing Hollow Output – Dimensional Data

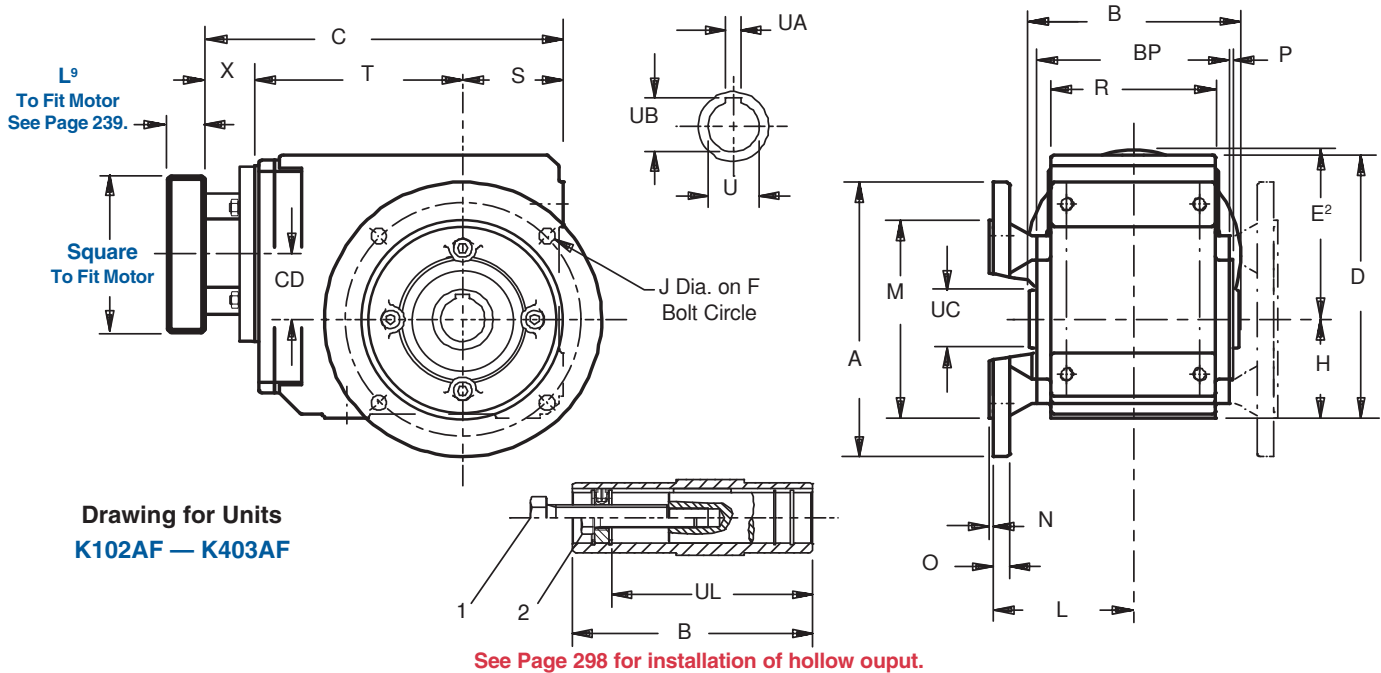

Table No. 1 "K" Series – Hollow Output, Round Flange Unit Dimensions (mm) – "F" Housing Style

Base Module	A	B	D	F	H	J	L	M	N	O	P	R	S	Z ₁	BP	UC	UL
K102	160	120	160	130	60	9	85	110 _{j6}	3.5	10	4	90	60	—	106	40	98
K202/203	200	148	190	165	65	11	99	130 _{j6}	3.5	12	4	115	65	—	134	45	121.5
K302/303	200	160	213	165	75	11	111	130 _{j6}	3.5	14	4	130	75	—	146	50	125
K402/403	250	188	240	215	90	14	126.5	180 _{j6}	4	15	4	148	90	—	173	55	157
K513/514	250	200	260	215	160	14	132	180 _{j6}	4	15	4	160	100	312	185	65	164
K613/614	300	215	310	265	190	14	136	230 _{j6}	4	17	4	168	120	362	200	70	179
K713/714	350	242	342	300	212	18	157	250 _{h6}	5	18	4.5	190	125	403	226	85	214
K813/814	400	300	410	350	265	18	186	300 _{h6}	5	20	5	235	145	471	282	100	263
K913/914	450	350	495	400	315	18	215	350 _{h6}	5	23	5	285	180	565	330	120	302
K1013/K1014	550	410	591	500	375	18	256	450 _{h6}	5	25	7	356	225	680	400	130	361

1. Removal Bolt – not supplied. See Page 298.
2. Mounting Bolt – must be smaller than removal bolt.

Table No. 2

Metric and Stainless Output available on request. Contact STOBER Drives for delivery.

Base Module	Standard Bore - Inches			Metric Bore - mm			Stainless Bore	
	U	UA	UB	U	UA	UB	Inches	mm
K102	1.000 _{G7}	.250	1.11	25 _{H7}	8 _{JS9}	28.3	1.000	25
K202/203	1.1875 _{G7}	.250	1.31	30 _{H7}	8 _{JS9}	33.3	1.125, 1.1875, 1.25	30
K302/303	1.375 _{G7}	.312	1.52	35 _{H7}	10 _{JS9}	38.3	1.25, 1.375	35
K402/403	1.500 _{G7}	.375	1.67	40 _{H7}	12 _{JS9}	43.3	1.375, 1.500	40
K513/514	2.000 _{G7}	.500	2.13	50 _{H7}	14 _{JS9}	53.8	1.4375, 1.9375, 2.000	40, 50
K613/614	2.000 _{G7}	.500	2.23	50 _{H7}	14 _{JS9}	53.8	1.4375, 1.9375, 2.000, 2.1875	40, 50, 60
K713/714	2.375 _{G7}	.625	2.66	60 _{H7}	18 _{JS9}	64.4	1.9375, 2.00, 2.1875, 2.375	60
K813/814	2.750 _{G7}	.625	3.03	70 _{H7}	20 _{JS9}	74.9	2.1875, 2.375, 2.5, 2.6875, 2.750	60, 70
K913/914	3.250 _{G7}	.750	3.59	90 _{H7}	25 _{JS9}	95.4	2.6875, 2.9375, 3.000, 3.25, 3.4375	90
K1013/K1014	4.000 _{G7}	1.000	4.31	100 _{H7}	28 _{JS9}	116	3.4375, 4.00	—

Part No. Example

Round Flange with TriAdapt® Motor Adapter

K303AF0650 MT20

For approximate weight, add adapter weight from Table 3 and base module weight from Table 4.



ServoFit® "K" Series – Helical/Bevel Round Flange – "F" Housing Hollow Output – Dimensional Data

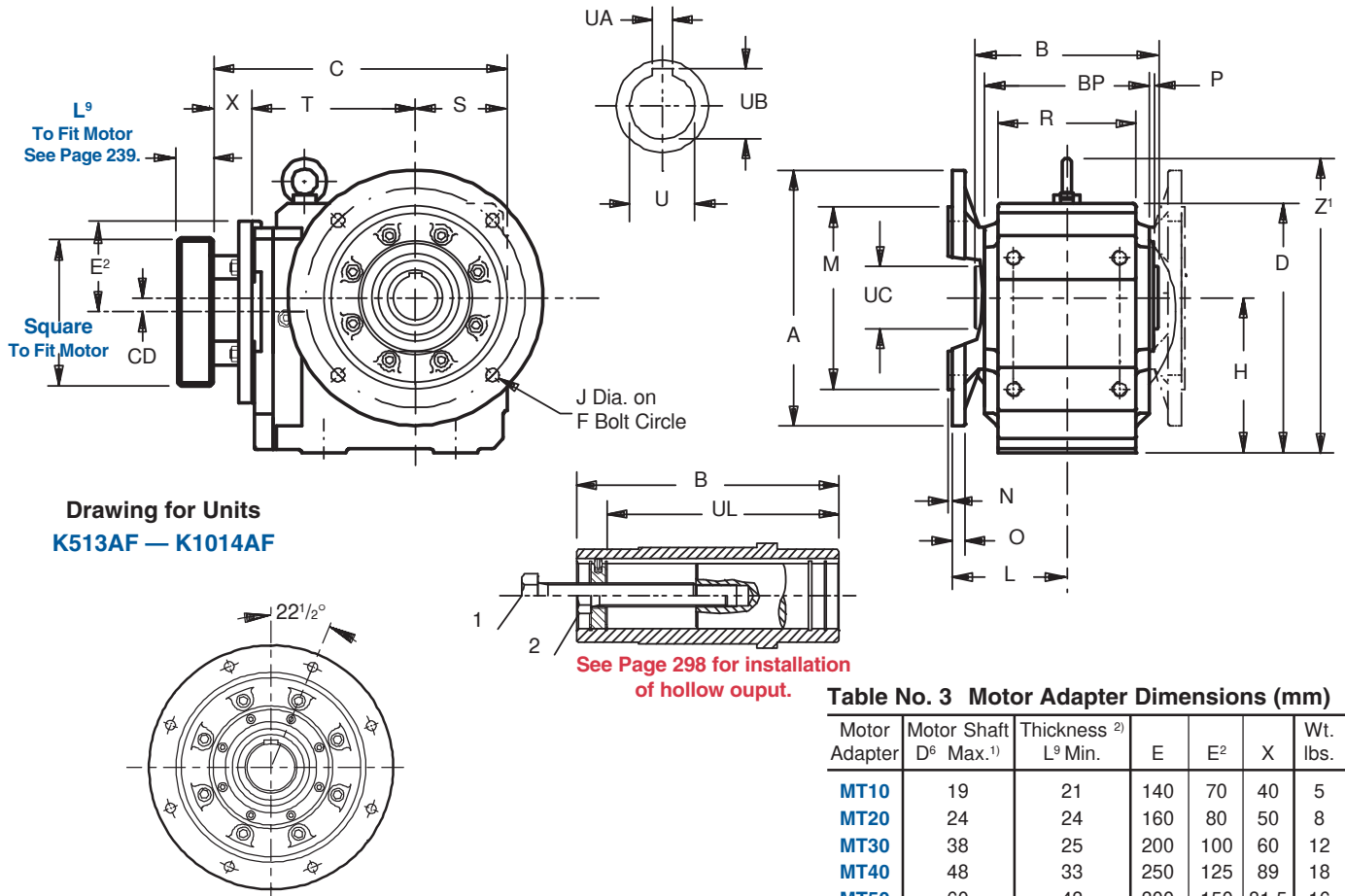
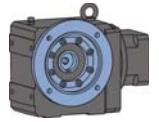

K913 thru K1014 has 8 mounting holes in the output flange located as shown.

Table No. 3 Motor Adapter Dimensions (mm)

Motor Adapter	Motor Shaft D ⁶ Max. ¹⁾	Thickness ²⁾ L ⁹ Min.	E	E ²	X	Wt. lbs.
MT10	19	21	140	70	40	5
MT20	24	24	160	80	50	8
MT30	38	25	200	100	60	12
MT40	48	33	250	125	89	18
MT50	60	43	300	150	81.5	16

- 1) If an adapter bushing is required it will be supplied as a component of the motor mounting plate.
- 2) Motor plate maximum thickness (L⁹) will vary with motor shaft length but will not be less than shown.

Table No. 4 "K" Series – Flange Mounting Unit Dimensions (mm) – "F" Housing Style

Base Module	MT10			MT20			MT30			MT40			MT50			Wt. lbs.
	CD	C	T	CD	C	T	CD	C	T	CD	C	T	CD	C	T	
K102	36	224	124	36	238	128	—	—	—	—	—	—	—	—	—	31
K202	46	248	143	46	262	147	46	274	149	—	—	—	—	—	—	40
K203	46	285	180	—	—	—	—	—	—	—	—	—	—	—	—	53
K302	52.5	278	163	52.5	292	167	52.5	304	169	—	—	—	—	—	—	67
K303	52.5	315	200	16	335	210	—	—	—	—	—	—	—	—	—	73
K402	—	—	—	60	327	187	60	339	189	60	371	192	—	—	—	93
K403	60	350	220	23	370	230	—	—	—	—	—	—	—	—	—	100
K513	—	—	—	15	322	172	15	334	174	15	366	177	—	—	—	106
K514	—	—	—	15	365	215	—	—	—	—	—	—	—	—	—	109
K613	—	—	—	18	361	191	18	373	193	18	405	196	18	411.5	210	170
K614	—	—	—	18	404	234	—	—	—	—	—	—	—	—	—	177
K713	—	—	—	—	—	—	20	406	221	20	438	224	20	443.5	237	221
K714	—	—	—	20	438	263	20	468	283	—	—	—	—	—	—	234
K813	—	—	—	—	—	—	24	452	247	24	483	249	24	488.5	262	309
K814	—	—	—	—	—	—	24	513	308	5	554	320	—	—	—	331
K913	—	—	—	—	—	—	—	—	—	25	563	294	25	568.5	307	508
K914	—	—	—	—	—	—	25	593	353	25	634	365	—	—	—	530
K1013	—	—	—	—	—	—	—	—	—	—	—	—	28	698.5	392	1,055
K1014	—	—	—	—	—	—	—	—	—	28	764	450	28	781.5	475	1,079

See Page 238 for Options and Part Number Configuration.



ServoFit® "K" Series – Helical/Bevel Tapped Hole – "G" Housing Hollow Output – Dimensional Data

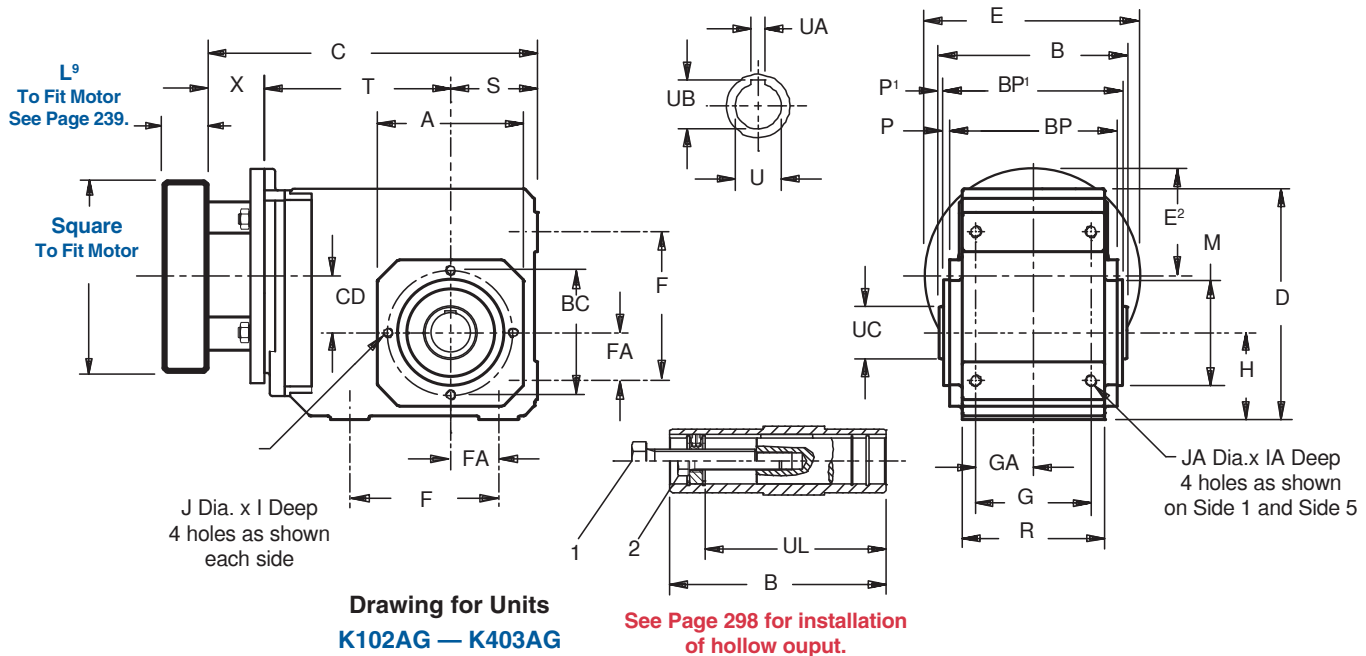

Table No. 1 "K" Series – Tapped Hole Unit Dimensions (mm) – "G" Housing Style

Base Module	A	B	D	F	G	H	I	J	M	P	P ¹	R	S	Z ¹	BC	BP	BP ¹	FA	GA	IA	JA	UC	UL
K102	105	120	160	90	70	60	13	4-M8	75 _{j6}	3	4	90	60	—	90	106	112	30	35	13	M8	40	98
K202/203	116	148	190	115	90	65	16	4-M8	82 _{j6}	3	4	115	65	—	100	134	140	35	45	16	M10	45	121.5
K302/303	132	160	213	130	105	75	16	4-M8	95 _{j6}	3	4	130	75	—	115	146	152	40	52.5	16	M10	50	125
K402/403	152	188	240	155	120	90	19	4-M10	110 _{j6}	3.5	4	148	90	—	130	173	180	50	60	19	M12	55	157
K513/514	145	200	260	140	125	160	26	8-M10	110 _{j6}	3.5	4	160	100	312	130	185	192	40	62.5	26	M16	65	164
K613/614	180	215	310	160	130	190	26	8-M10	140 _{j6}	3.5	4	168	120	362	165	200	207	50	65	26	M16	70	179
K713/714	195	242	342	180	145	212	31	8-M12	155 _{j6}	3.5	4.5	190	125	403	185	226	233	55	72.5	31	M20	85	214
K813/814	226	300	410	240	185	265	38	8-M12	185 _{j6}	4	5	235	145	471	215	282	290	75	92.5	38	M24	100	263
K913/914	280	350	495	280	225	315	48	8-M16	230 _{j6}	5	5	285	180	565	265	330	340	95	112.5	48	M30	120	302
K1013/K1014	340	410	591	350	330	375	33	10-M20	250 _{h6}	5	7	356	225	680	300	400	396	115	165	45	39	130	361

Table No. 2

Metric and Stainless Output available on request. Contact STOBER Drives for delivery.

Base Module	Standard Bore - Inches			Metric Bore - mm			Stainless Bore	
	U	UA	UB	U	UA	UB	Inches	mm
K102	1.000 _{G7}	.250	1.11	25 _{H7}	8 _{JS9}	28.3	1.000	25
K202/203	1.1875 _{G7}	.250	1.31	30 _{H7}	8 _{JS9}	33.3	1.125, 1.1875, 1.25	30
K302/303	1.375 _{G7}	.312	1.52	35 _{H7}	10 _{JS9}	38.3	1.25, 1.375	35
K402/403	1.500 _{G7}	.375	1.67	40 _{H7}	12 _{JS9}	43.3	1.375, 1.500	40
K513/514	2.000 _{G7}	.500	2.13	50 _{H7}	14 _{JS9}	53.8	1.4375, 1.9375, 2.000	40, 50
K613/614	2.000 _{G7}	.500	2.23	50 _{H7}	14 _{JS9}	53.8	1.4375, 1.9375, 2.000, 2.1875	40, 50, 60
K713/714	2.375 _{G7}	.625	2.66	60 _{H7}	18 _{JS9}	64.4	1.9375, 2.00, 2.1875, 2.375	60
K813/814	2.750 _{G7}	.625	3.03	70 _{H7}	20 _{JS9}	74.9	2.1875, 2.375, 2.5, 2.6875, 2.750	60, 70
K913/914	3.250 _{G7}	.750	3.59	90 _{H7}	25 _{JS9}	95.4	2.6875, 2.9375, 3.000, 3.25, 3.4375	90
K1013/K1014	4.000 _{G7}	1.000	4.31	100 _{H7}	28 _{JS9}	116	3.4375, 4.00	—

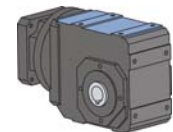

K1 Housing has tapped holes on Side 1, Side 2, and Side 5.

1. Removal Bolt – not supplied. See Page 298.
2. Mounting Bolt – must be smaller than removal bolt.
For approximate weight, add base module weight from Table 3 and adapter weight from Table 4.

Part No. Example
Tapped Holes Housing with TriAdapt® Motor Adapter
K303AG0650 MT20



ServoFit® "K" Series – Helical/Bevel Tapped Hole – "G" Housing Hollow Output – Dimensional Data

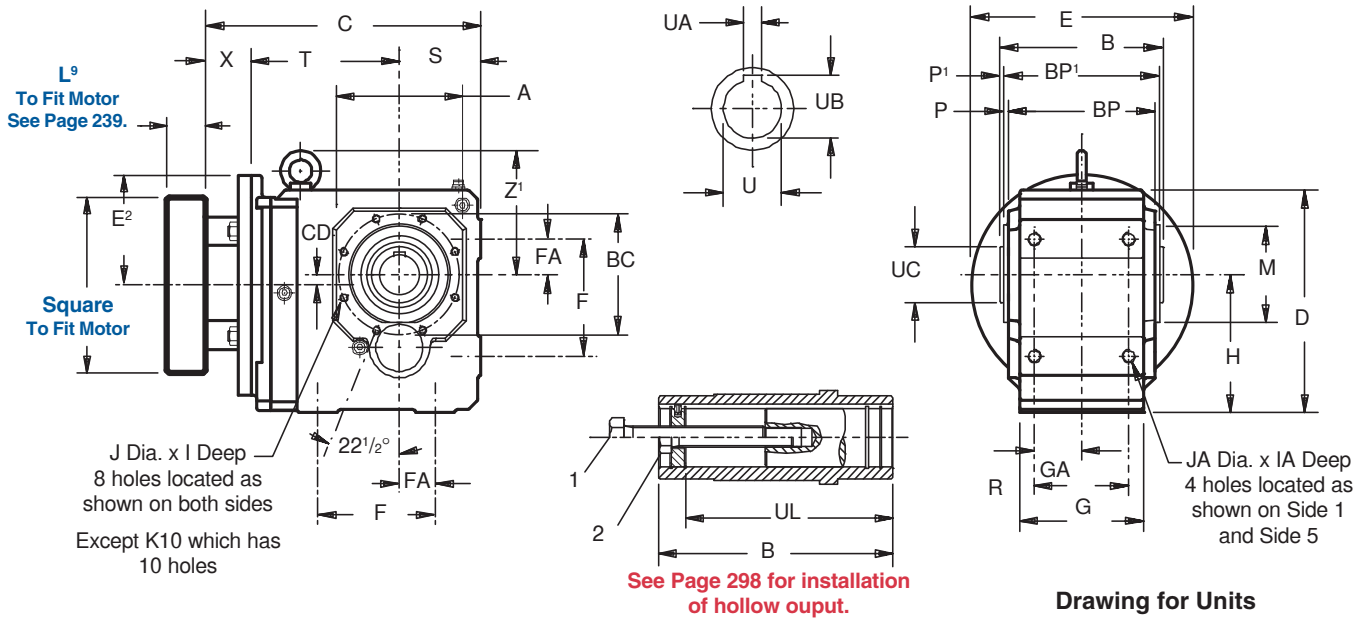

Table No. 3 "K" Series – Tapped Hole Unit Dimensions (mm) – "G" Housing Style

Base Module	MT10			MT20			MT30			MT40			MT50			Wt. lbs.
	CD	C	T	CD	C	T	CD	C	T	CD	C	T	CD	C	T	
K102	36	224	124	36	238	128	—	—	—	—	—	—	—	—	—	31
K202	46	248	143	46	262	147	46	274	149	—	—	—	—	—	—	40
K203	46	285	180	—	—	—	—	—	—	—	—	—	—	—	—	53
K302	52.5	278	163	52.5	292	167	52.5	304	169	—	—	—	—	—	—	67
K303	52.5	315	200	16	335	210	—	—	—	—	—	—	—	—	—	73
K402	—	—	—	60	327	187	60	339	189	60	371	192	—	—	—	93
K403	60	350	220	23	370	230	—	—	—	—	—	—	—	—	—	100
K513	—	—	—	15	322	172	15	334	174	15	366	177	—	—	—	106
K514	—	—	—	15	365	215	—	—	—	—	—	—	—	—	—	109
K613	—	—	—	18	361	191	18	373	193	18	405	196	18	411.5	210	170
K614	—	—	—	18	404	234	—	—	—	—	—	—	—	—	—	177
K713	—	—	—	—	—	—	20	406	221	20	438	224	20	443.5	237	221
K714	—	—	—	20	438	263	20	468	283	—	—	—	—	—	—	234
K813	—	—	—	—	—	—	24	452	247	24	483	249	24	488.5	262	309
K814	—	—	—	—	—	—	24	513	308	5	554	320	—	—	—	331
K913	—	—	—	—	—	—	—	—	—	25	563	294	25	568.5	307	508
K914	—	—	—	—	—	—	25	593	353	25	634	365	—	—	—	530
K1013	—	—	—	—	—	—	—	—	—	—	—	—	28	698.5	392	1,055
K1014	—	—	—	—	—	—	—	—	—	28	764	450	28	781.5	475	1,079

Table No. 4 Motor Adapter Dimensions (mm)

Motor Adapter	Motor Shaft D ⁶ Max. ¹⁾	Thickness ²⁾ L ⁹ Min.	E	E ²	X	Wt. lbs.
MT10	19	21	140	70	40	5
MT20	24	24	160	80	50	8
MT30	38	25	200	100	60	12
MT40	48	33	250	125	89	18
MT50	60	43	300	150	81.5	16

¹⁾ If an adapter bushing is required it will be supplied as a component of the motor mounting plate.

²⁾ Motor plate maximum thickness (L⁹) will vary with motor shaft length but will not be less than shown.

See Page 238 for Options and Part Number Configuration.

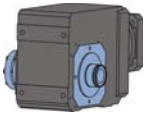

ServoFit® "K" Series – Helical/Bevel Tapped Hole – "G" Housing Single Bushing – Dimensional Data

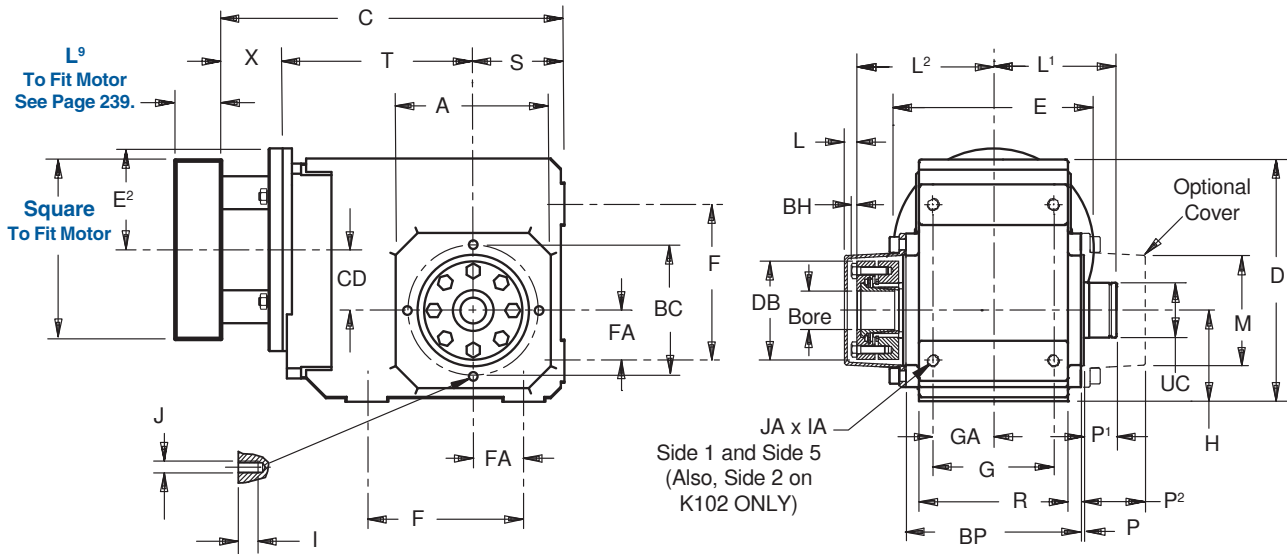

**Drawing for Units
K102WG — K403WG**

Important: A 1/32 x 45° chamfer minimum is recommended for the shaft end.
The bushing will accept a shaft with a tolerance of +.000/-.005 inches.

Table No. 1 "K" Series – Single Side Wobble Free – Unit Dimensions (mm)

Base Module	A	D	F	G	H	I	J	L	L ₁	L ₂	M	P	P ₁	P ₂	R	S	Z ₁	BC	BH
K102	105	160	90	70	60	13	4-M8	6	80	93	78	3	24	40	90	60	—	90	4
K202/203	1116	190	115	90	65	16	4-M8	10	96	108.5	88	3	26	50	115	65	—	100	4
K302/303	132	213	130	105	75	16	4-M8	11	102	115.5	88	3	26	52	130	75	—	115	4
K402/403	152	240	155	120	90	19	4-M10	12	119	135	110	3.5	29	53	148	90	—	130	5
K513/514	145	260	140	125	160	26	8-M10	11	126	142.5	115	3.5	30	61	160	100	312	130	5
K613/614	180	310	160	130	190	26	8-M10	13	130	155	127	3.5	35	68	168	120	362	165	6
K713/714	195	342	180	145	212	31	8-M12	10	157.5	185	146	3.5	41	74	190	125	403	185	6
K813/814	226	410	240	185	265	38	8-M12	16	192.5	221	176.5	4	51.5	87	235	145	471	215	6

Table No. 2 Unit Dimensions (mm)

Base Module	BP	DB	FA	GA	IA	JA	UC
K102	106	70	30	35	13	M8	39
K202/203	134	78	35	45	16	M10	44
K302/303	146	84	40	52.5	16	M10	44
K402/403	173	97	50	60	19	M12	54
K513/514	185	105	40	62.5	26	M16	65
K613/614	200	118	50	65	26	M16	74
K713/714	226	138	55	72.5	31	M20	85
K813/814	282	158	75	92.5	38	M24	100

Table No. 3 Motor Adapter Dimensions (mm)

Motor Adapter	Motor Shaft D ⁶ Max. ¹⁾	Thickness ²⁾ L ⁹ Min.	E	E ²	X	Wt. lbs.
MT10	19	21	140	70	40	5
MT20	24	24	160	80	50	8
MT30	38	25	200	100	60	12
MT40	48	33	250	125	89	18
MT50	60	43	300	150	81.5	16

¹⁾ If an adapter bushing is required it will be supplied as a component of the motor mounting plate.
²⁾ Motor plate maximum thickness (L⁹) will vary with motor shaft length but will not be less than shown.

Table No. 4

"WF" Single Side Bushing – Metric

Unit	Stock Bore Sizes — mm		
	25	30	35
K1	WF1-25	—	—
K2	—	WF2-30	—
K3	—	WF3-30	WF3-35

Table No. 5 "WF" Single Side Bushing – Inches

Unit	Stock Bore Sizes					
	1	1 ³ / ₁₆	1 ¹ / ₄	1 ³ / ₈	1 ⁷ / ₁₆	1 ¹ / ₂
K1	WF1-100	—	—	—	—	—
K2	WF2-100	WF2-103	—	—	—	—
K3	WF3-100	WF3-103	WF3-104	WF3-106	WF3-107	WF3-108
K4	WF4-100	WF4-103	WF4-104	WF4-106	WF4-107	WF4-108



ServoFit® "K" Series – Helical/Bevel Tapped Hole – "G" Housing Single Bushing – Dimensional Data

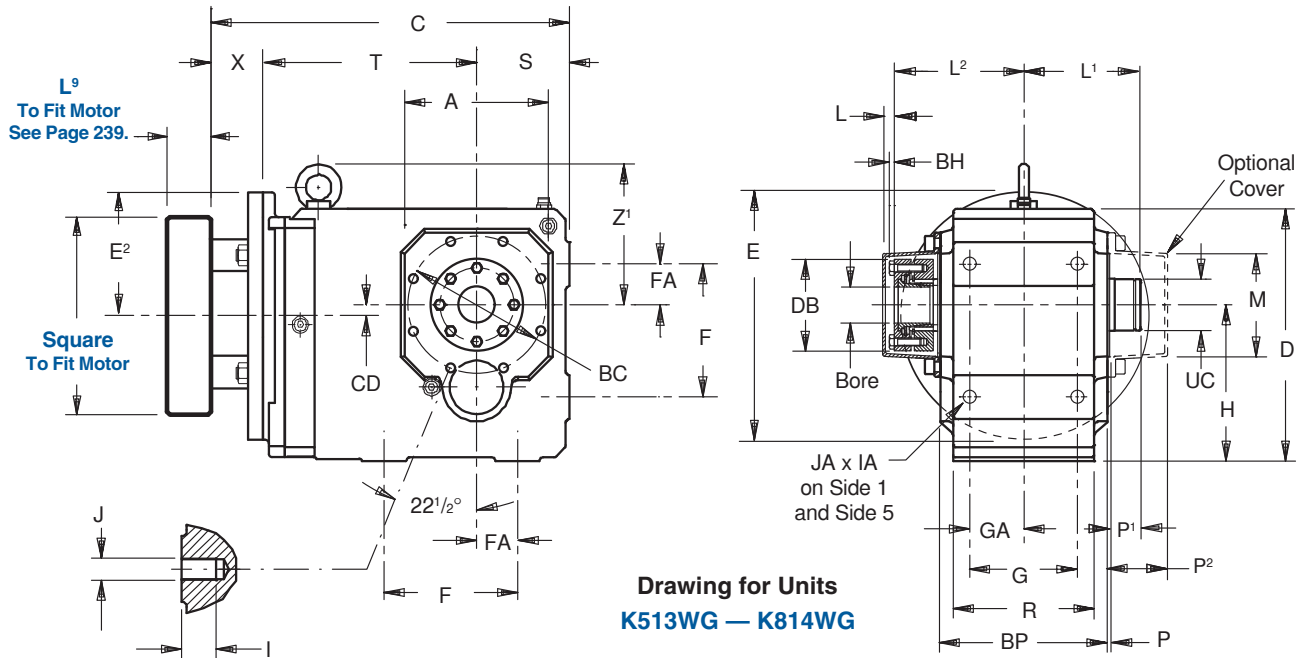
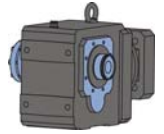

Drawing for Units
K513WG – K814WG

Table No. 6 "K" Series – Single Side Bushing – Unit Dimensions (mm) – "G" Housing Style

Base Module	MT10			MT20			MT30			MT40			MT50			Wt. lbs.
	CD	C	T	CD	C	T	CD	C	T	CD	C	T	CD	C	T	
K102	36	224	124	36	238	128	—	—	—	—	—	—	—	—	—	31
K202	46	248	143	46	262	147	46	274	149	—	—	—	—	—	—	40
K203	46	285	180	—	—	—	—	—	—	—	—	—	—	—	—	53
K302	52.5	278	163	52.5	292	167	52.5	304	169	—	—	—	—	—	—	67
K303	52.5	315	200	16	335	210	—	—	—	—	—	—	—	—	—	73
K402	—	—	—	60	327	187	60	339	189	60	371	192	—	—	—	93
K403	60	350	220	23	370	230	—	—	—	—	—	—	—	—	—	100
K513	—	—	—	15	322	172	15	334	174	15	366	177	—	—	—	106
K514	—	—	—	15	365	215	—	—	—	—	—	—	—	—	—	109
K613	—	—	—	18	361	191	18	373	193	18	405	196	18	411.5	210	170
K614	—	—	—	18	404	234	—	—	—	—	—	—	—	—	—	177
K713	—	—	—	—	—	—	20	406	221	20	438	224	20	443.5	237	221
K714	—	—	—	20	438	263	20	468	283	—	—	—	—	—	—	234
K813	—	—	—	—	—	—	24	452	247	24	483	249	24	488.5	262	309
K814	—	—	—	—	—	—	24	513	308	5	554	320	—	—	—	331

Part No. Example

Unit with TriAdapt® Motor Adapter
1 3/8" Bore Single Bushing
K402WG0560 MT20
WF4-106

SPECIFY BUSHING SIDE WHEN ORDERING

NOTES: A complete bushing kit includes the locking ring assembly, tapered cone, support ring, and all hardware to mount the kit into the reducer. The WF1-100 bushing does not have a tapered cone. The optional cover caps can be ordered separately.

Table No. 7 "WF" Single Side Bushings – Inches

Unit	Stock Bore Sizes — Inches											
	17/16	1 1/2	1 5/8	1 11/16	1 3/4	1 7/8	1 15/16	2	2 3/16	2 3/8	2 7/16	2 3/4
K5	WF5-107	WF5-108	WF5-110	WF5-111	WF5-112	WF5-114	WF5-115	WF5-200	—	—	—	—
K6	WF6-107	WF6-108	WF6-110	WF6-111	WF6-112	—	WF6-115	WF6-200	WF6-203	—	—	—
K7	—	—	—	—	—	—	WF7-115	WF7-200	WF7-203	WF7-206	—	—
K8	—	—	—	—	—	—	—	—	WF8-203	WF8-206	WB7-207	WF8-212

See Page 238 for Options and Part Number Configuration.



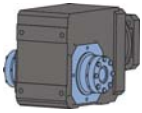

ServoFit® "K" Series – Helical/Bevel Tapped Hole – "G" Housing Double Bushing – Dimensional Data

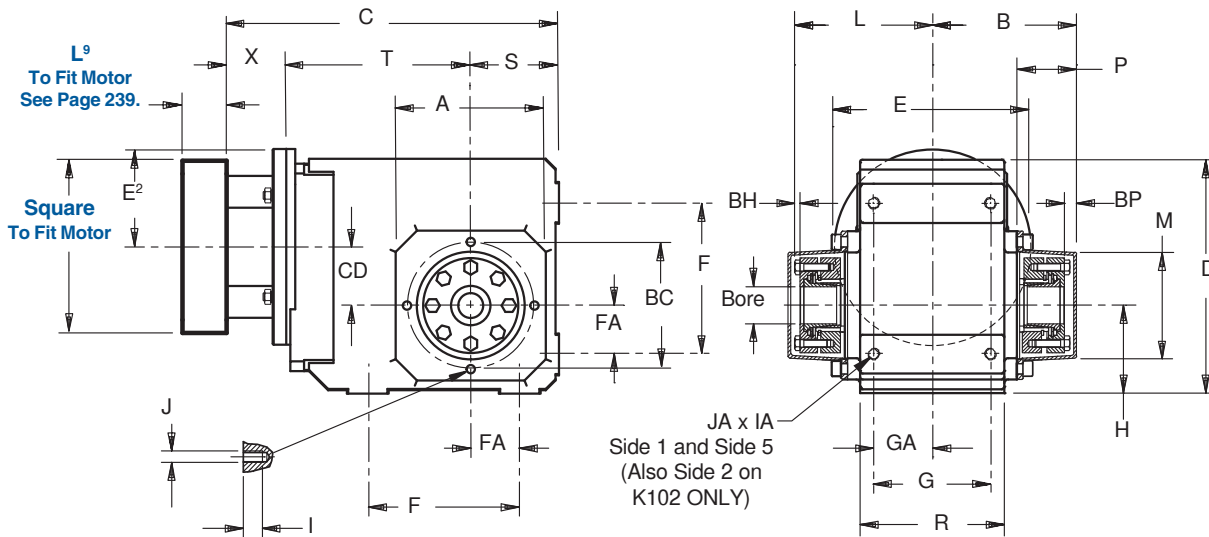

Drawing for Units

K102WG — K403WG

Important: A 1/32 x 45° chamfer minimum is recommended for the shaft end.
The bushing will accept a shaft with a tolerance of +.000/-.005 inches.

Table No. 1 "K" Series – Double Side Bushing – Unit Dimensions (mm)

Base Module	A	B	D	F	G	H	I	J	L	M	P	R	S	Z ¹	BC	BP	BH	FA	GA	IA	JA
K102	105	99	160	90	70	60	13	4-M8	97	78	50	90	60	—	90	6	4	30	35	13	M8
K202/203	116	118.5	190	115	90	65	16	4-M8	113	88	52	115	65	—	100	10	4	35	45	16	M10
K302/303	132	126.5	213	130	105	75	16	4-M8	119.5	88	53	130	75	—	115	11	4	40	52.5	16	M10
K402/403	152	147	240	155	120	90	19	4-M10	140.5	110	61	148	90	—	130	12	5	50	60	19	M12
K513/514	145	153.5	260	140	125	160	26	8-M10	147.5	115	61	160	100	312	130	11	5	40	62.5	26	M16
K613/614	180	168	310	160	130	190	26	8-M10	161	127	68	168	120	362	165	13	6	50	65	26	M16
K713/714	195	185	342	180	145	212	31	8-M12	191.5	146	74	190	125	403	185	10	6	55	72.5	31	M20
K813/814	226	221	410	240	185	265	38	8-M12	229	176.5	87	235	145	471	215	16	8	75	92.5	38	M24

Table No. 2 Motor Adapter Dimensions (mm)

Motor Adapter	Motor Shaft D ⁶ Max. ¹⁾	Thickness ²⁾ L ⁹ Min.	E	E ²	X	Wt. lbs.
MT10	19	21	140	70	40	5
MT20	24	24	160	80	50	8
MT30	38	25	200	100	60	12
MT40	48	33	250	125	89	18
MT50	60	43	300	150	81.5	16

¹⁾ If an adapter bushing is required it will be supplied as a component of the motor mounting plate.
²⁾ Motor plate maximum thickness (L⁹) will vary with motor shaft length but will not be less than shown.

Table No. 3

"WFB" – Double Bushings – Metric

Unit	Stock Bores Sizes — mm			
	25	30	35	40
K1	WFB1-25	—	—	—
K2	WFB2-25	WFB2-30	—	—
K3	—	WFB3-30	WFB3-35	—
K4	—	—	—	WFB4-40
K5	—	—	—	WFB5-40
K6	—	—	—	WFB6-40

Table No. 4 "WFB" Double Side Bushings – Inches

Unit	Stock Bores Sizes					
	1	1 ³ / ₁₆	1 ¹ / ₄	1 ³ / ₈	1 ⁷ / ₁₆	1 ¹ / ₂
K1	WFB1-100	—	—	—	—	—
K2	WFB2-100	WFB2-103	—	—	—	—
K3	WFB3-100	WFB3-103	WFB3-104	WFB3-106	WFB3-107	WFB3-108
K4	WFB4-100	WFB4-103	WFB4-104	WFB4-106	WFB4-107	WFB4-108



ServoFit® "K" Series – Helical/Bevel Tapped Hole – "G" Housing Double Bushing – Dimensional Data

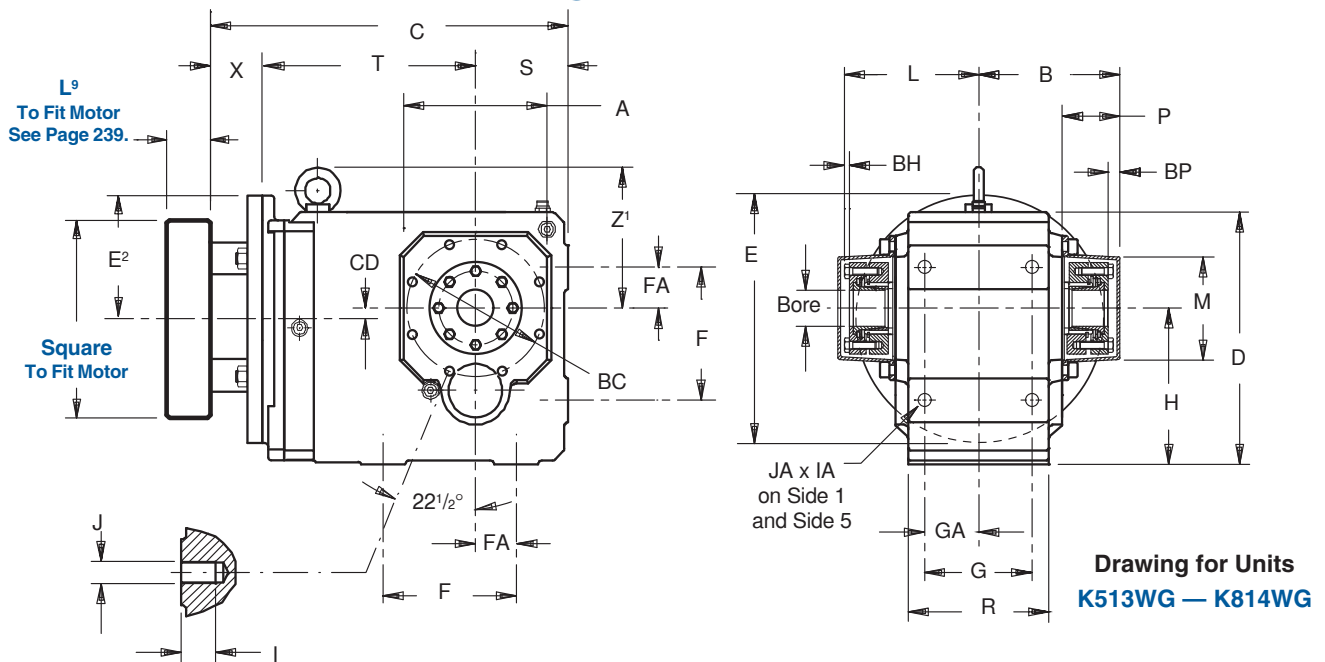
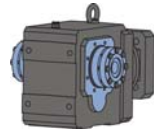

Table No. 5 "K" Series – Double Wobble Free – Unit Dimensions (mm)

Base Module	MT10			MT20			MT30			MT40			MT50			Wt. lbs.
	CD	C	T	CD	C	T	CD	C	T	CD	C	T	CD	C	T	
K102	36	224	124	36	238	128	—	—	—	—	—	—	—	—	—	31
K202	46	248	143	46	262	147	46	274	149	—	—	—	—	—	—	40
K203	46	285	180	—	—	—	—	—	—	—	—	—	—	—	—	53
K302	52.5	278	163	52.5	292	167	52.5	304	169	—	—	—	—	—	—	67
K303	52.5	315	200	16	335	210	—	—	—	—	—	—	—	—	—	73
K402	—	—	—	60	327	187	60	339	189	60	371	192	—	—	—	93
K403	60	350	220	23	370	230	—	—	—	—	—	—	—	—	—	100
K513	—	—	—	15	322	172	15	334	174	15	366	177	—	—	—	106
K514	—	—	—	15	365	215	—	—	—	—	—	—	—	—	—	109
K613	—	—	—	18	361	191	18	373	193	18	405	196	18	411.5	210	170
K614	—	—	—	18	404	234	—	—	—	—	—	—	—	—	—	177
K713	—	—	—	—	—	—	20	406	221	20	438	224	20	443.5	237	221
K714	—	—	—	20	438	263	20	468	283	—	—	—	—	—	—	234
K813	—	—	—	—	—	—	24	452	247	24	483	249	24	488.5	262	309
K814	—	—	—	—	—	—	24	513	308	5	554	320	—	—	—	331

Part No. Example

Unit with TriAdapt® Motor Adapter
1 3/8" Bore Double Bushing
K402WG0560 MT20
WFB4-106

NOTES: A complete bushing kit includes the locking ring assembly, tapered cone, support ring, and all hardware to mount the kit into the reducer. The WFB1-100 bushing does not have a tapered cone.

Table No. 6 "WFB" Double Side Bushings – Inches

Unit	Stock Bores Sizes — Inches											
	17/16	1 1/2	1 5/8	1 11/16	1 3/4	1 7/8	1 15/16	2	2 3/16	2 3/8	2 7/16	2 3/4
K5	WFB5-107	WFB5-108	WFB5-110	WFB5-111	WFB5-112	WFB5-114	WFB5-115	WFB5-200	—	—	—	—
K6	WFB6-107	WFB6-108	WFB6-110	WFB6-111	WFB6-112	—	WFB6-115	WFB6-200	WFB6-203	—	—	—
K7	—	—	—	—	—	—	WFB7-115	WFB7-200	WFB7-203	WFB7-206	—	—
K8	—	—	—	—	—	—	—	—	WFB8-203	WFB8-206	WFB7-207	WFB8-212

See Page 238 for Options and Part Number Configuration.



ServoFit® "K" Series – Helical/Bevel Tapped Hole – "G" Housing Shrink Ring – Dimensional Data

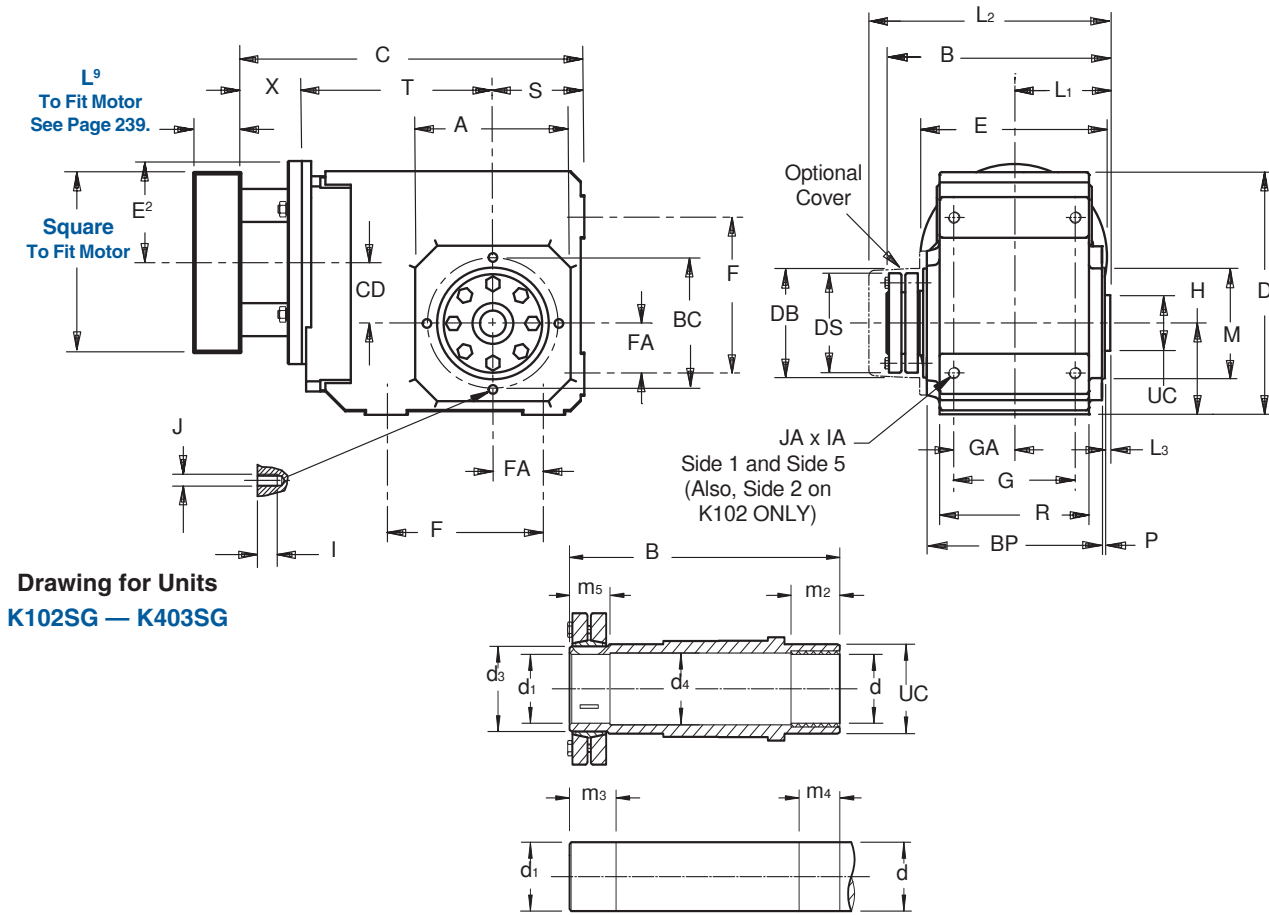

Drawing for Units
K102SG — K403SG

See Page 294 for shrink ring installation.

Table No. 1 "K" Series – Shrink Ring – Unit Dimensions (mm)

Base Module	A	B	D	F	G	H	I	J	L ¹	L ₂	L ₃	M	P	R	S	Z ₁	BC	BP
K102	105	120	160	90	70	60	13	4-M8	60	163	4	75 _{js}	3	90	60	—	90	106
K202/203	116	148	190	115	90	65	16	4-M8	74	193	4	82 _{js}	3	115	65	—	100	134
K302/303	132	160	213	130	105	75	16	4-M8	80	206	4	95 _{js}	3	130	75	—	115	146
K402/403	152	188	240	155	120	90	19	4-M10	94	242	4	110 _{js}	3.5	148	90	—	130	173
K513/514	145	200	260	140	125	160	26	8-M10	100	254	4	110 _{js}	3.5	160	100	312	130	185
K613/614	180	215	310	160	130	190	26	8-M10	107.5	276	4	140 _{js}	3.5	168	120	362	165	200
K713/714	195	242	342	180	145	212	31	8-M12	121	288	4.5	155 _{js}	3.5	190	125	403	185	226
K813/814	226	300	410	240	185	265	38	8-M12	150	362	5	185 _{js}	4	235	145	471	215	282
K913/914	280	350	495	280	225	315	48	8-M16	175	425	5	230 _{js}	5	285	180	565	265	330
K1013/1014	340	410	591	350	330	375	33	10-M20	205	497	7	250 _{h6}	7	356	225	680	300	400

K

Table No. 2

Base Module	DB	DS	FA	GA	IA	JA	UC
K1	80	60	30	35	13	M8	40
K2	88	72	35	45	16	M10	45
K3	101	80	40	52.5	16	M10	50
K4	114	90	50	60	19	M12	55
K5	116	106	40	62.5	26	M16	65
K6	128	106	50	65	26	M16	70
K7	164	138	55	72.5	31	M20	85
K8	203	155	75	92.5	38	M24	100
K9	244	200	95	112.5	48	M30	120
K10	274	230	115	165	45	39	130

Table No. 3

Shaft Dimensions (mm)

Base Module	d	Bore		d ₃	d ₄	m ₂	m ₃	m ₄	m ₅
		d ₁	Shaft						
K1	25 _{h9}	25 ^{H7}	25 _{h9}	30	25.5	20	34	25	29
K2	30 _{h9}	30 ^{H7}	30 _{h9}	36	30.5	25	39	30	34
K3	35 _{h9}	35 ^{H7}	35 _{h9}	44	35.5	30	39	35	34
K4	40 _{h9}	40 ^{H7}	40 _{h9}	50	40.5	40	39	45	34
K5	50 _{h9}	50 ^{H7}	50 _{h9}	62	50.5	40	44	45	39
K6	50 _{h9}	50 ^{H7}	50 _{h9}	62	50.5	40	45	45	40
K7	60 _{h6}	60 ^{H7}	60 _{h6}	75	62	40	45	45	40
K8	70 _{h6}	70 ^{H7}	70 _{h6}	90	72	50	60	60	50
K9	90 _{h6}	90 ^{H7}	90 _{h6}	120	92	60	70	70	60
K10	100 _{h6}	100 ^{H7}	100 _{h6}	130	102	60	80	70	70



ServoFit® "K" Series – Right Angle Helical/Bevel Tapped Hole – "G" Housing Shrink Ring – Dimensional Data

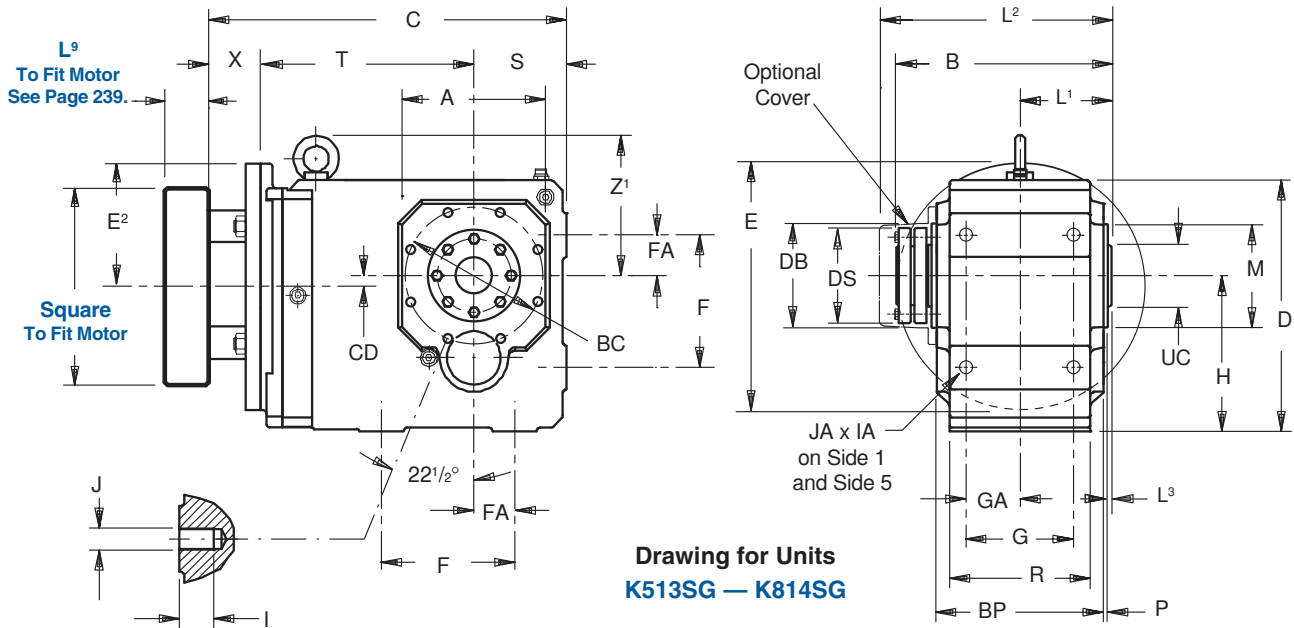

Table No. 4 "K" Series – Shrink Ring – Unit Dimensions (mm) – "G" Housing Style

Base Module	MT10			MT20			MT30			MT40			MT50			Wt. lbs.
	CD	C	T	CD	C	T	CD	C	T	CD	C	T	CD	C	T	
K102	36	224	124	36	238	128	—	—	—	—	—	—	—	—	—	31
K202	46	248	143	46	262	147	46	274	149	—	—	—	—	—	—	40
K203	46	285	180	—	—	—	—	—	—	—	—	—	—	—	—	53
K302	52.5	278	163	52.5	292	167	52.5	304	169	—	—	—	—	—	—	67
K303	52.5	315	200	16	335	210	—	—	—	—	—	—	—	—	—	73
K402	—	—	—	60	327	187	60	339	189	60	371	192	—	—	—	93
K403	60	350	220	23	370	230	—	—	—	—	—	—	—	—	—	100
K513	—	—	—	15	322	172	15	334	174	15	366	177	—	—	—	106
K514	—	—	—	15	365	215	—	—	—	—	—	—	—	—	—	109
K613	—	—	—	18	361	191	18	373	193	18	405	196	18	411.5	210	170
K614	—	—	—	18	404	234	—	—	—	—	—	—	—	—	—	177
K713	—	—	—	—	—	—	20	406	221	20	438	224	20	443.5	237	221
K714	—	—	—	20	438	263	20	468	283	—	—	—	—	—	—	234
K813	—	—	—	—	—	—	24	452	247	24	483	249	24	488.5	262	309
K814	—	—	—	—	—	—	24	513	308	5	554	320	—	—	—	331
K913	—	—	—	—	—	—	—	—	—	25	563	294	25	568.5	307	508
K914	—	—	—	—	—	—	25	593	353	25	634	365	—	—	—	530
K1013	—	—	—	—	—	—	—	—	—	—	—	—	28	698.5	392	1,055
K1014	—	—	—	—	—	—	—	—	—	28	764	450	28	781.5	475	1,079

Table No. 5 Motor Adapter Dimensions (mm)

Motor Adapter	Motor Shaft D ⁶ Max. ¹⁾	Thickness ²⁾ L ⁹ Min.	E	E ²	X	Wt. lbs.
MT10	19	21	140	70	40	5
MT20	24	24	160	80	50	8
MT30	38	25	200	100	60	12
MT40	48	33	250	125	89	18
MT50	60	43	300	150	81.5	16

Part No. Example

Unit with TriAdapt® Motor Adapter
1 3/8" Bore Single Bushing

**K402SG0560 MT20
WF4-106**

SPECIFY BUSHING SIDE WHEN ORDERING

¹⁾ If an adapter bushing is required it will be supplied as a component of the motor mounting plate.

²⁾ Motor plate maximum thickness (L⁹) will vary with motor shaft length but will not be less than shown.

See Page 238 for Options and Part Number Configuration.



ServoFit® "K" Series – Right Angle Helical/Bevel Torque Arm Bracket Dimensional Data



(Torque arm supplied by others.)

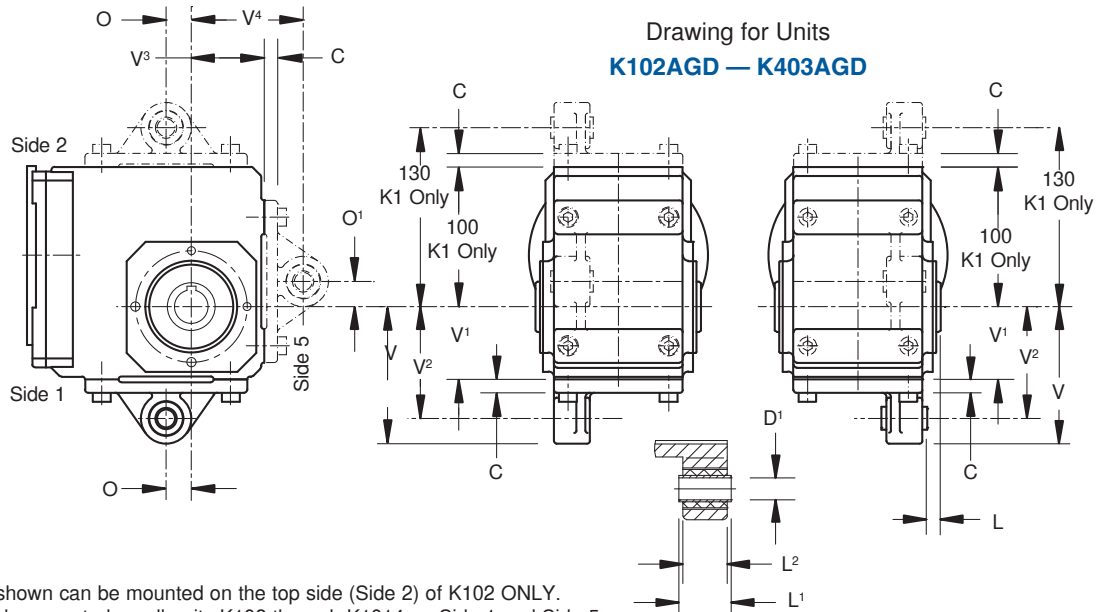

The bracket as shown can be mounted on the top side (Side 2) of K102 ONLY.
All brackets can be mounted on all units K102 through K1014 on Side 1 and Side 5.

Table No. 1 "K" Series — Torque Arm Bracket Dimensions (mm)

Base Module	C	D ¹	L	L ¹	L ²	O	O ¹	V	V ¹	V ²	V ³	V ⁴
K102	10	12 _{H9}	13	28	24	15	15	111.5	60	90	60	90
K202/K203	12	16 _{H9}	13.5	38	32	22.5	22.5	122.5	65	100	65	100
K302/K303	12	16 _{H9}	12	38	32	25	25	142.5	75	120	75	120
K402/K403	14	20 _{H9}	17	46	40	27.5	27.5	177.5	90	150	90	150
K513/K514	15	20 _{H9}	17	46	40	30	30	279	160	250	100	190
K613/K614	15	20 _{H9}	20.5	46	40	30	30	279	190	250	120	180
K713/K714	17	20 _{H9}	23	70	64	35	35	334	212	300	125	213
K813/K814	17	24 _{H9}	26	115	102	45	45	386	265	350	145	230
K913/K914	20	24 _{H9}	26	115	102	45	45	487.5	315	450	180	315
K1013/1014	42	40 _{H9}	6	124	118	60	55	610	375	550	225	400

Drawing for Units
K513AGD — K1014AGD

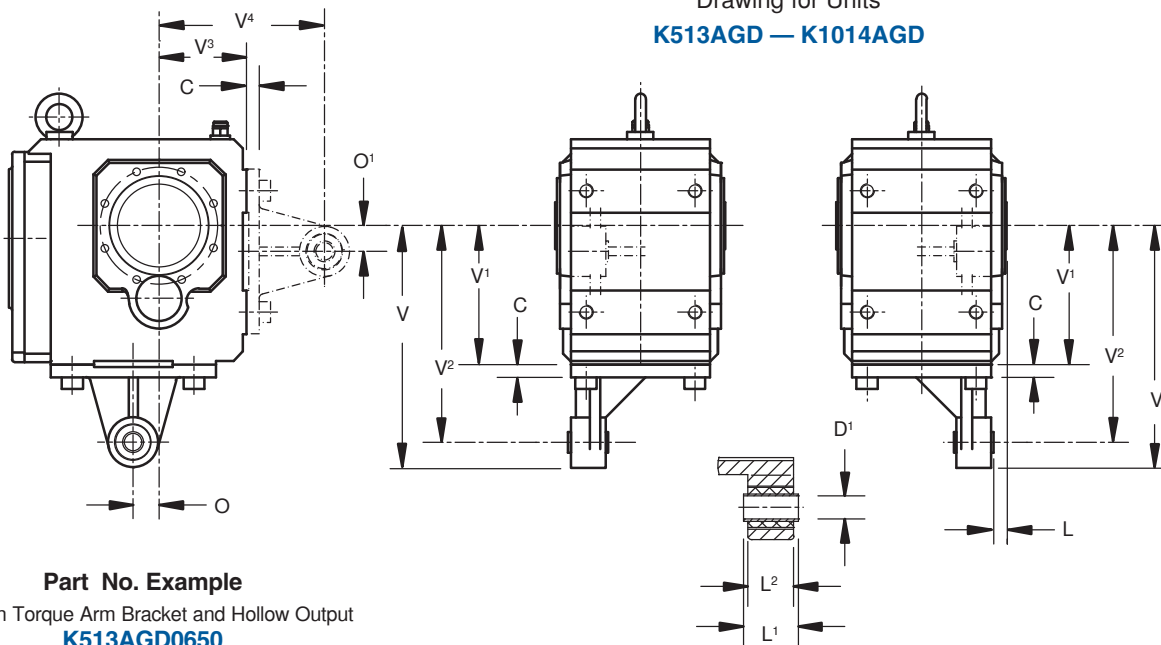

Part No. Example

Unit with Torque Arm Bracket and Hollow Output
K513AGD0650

K



ServoFit® "K" Series – Right Angle Helical/Bevel Optional Round Flange Sizes Dimensional Data

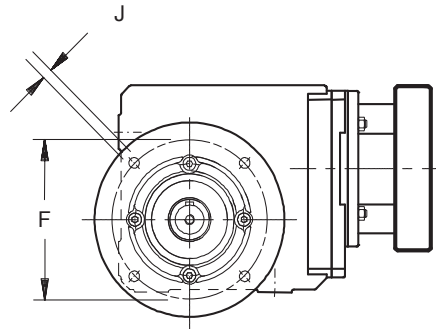
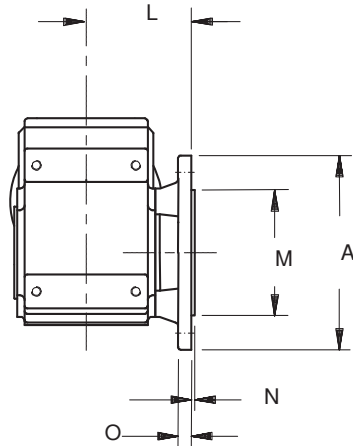
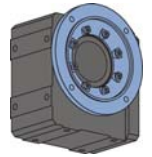

Drawing for Units
K102F—K403F

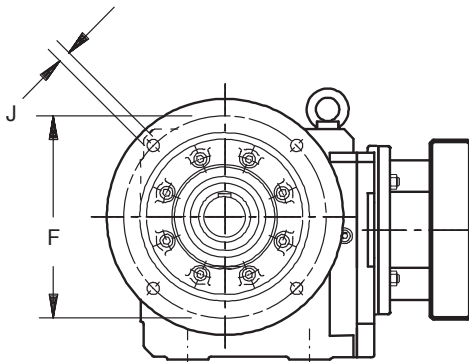

Drawing for Units
K513F—K814F

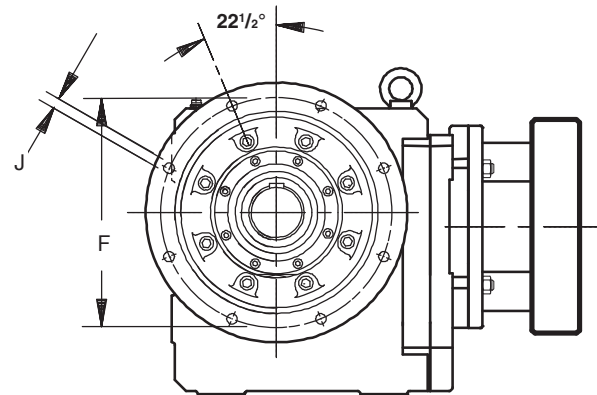

Drawing for Units
K913-K1014F

Table No. 1 "K" Series — Optional Flange Dimensions (mm)

Base Module	Flange Designation	A	F	J	L	M	N	O
K102	140	140	115	9	85	95 _{±6}	3	10
	160 *	160	130	9	85	110 _{±6}	3.5	10
K202/K203	160	160	130	9	99	110 _{±6}	3.5	12
	200 *	200	165	11	99	130 _{±6}	3.5	12
K302/K303	160	160	130	9	111	110 _{±6}	3.5	14
	200 *	200	165	11	111	130 _{±6}	3.5	14
	250	250	215	14	111	180 _{±6}	4	14
K402/K403	250 *	250	215	14	126.5	180 _{±6}	4	15
K513/K514	250 *	250	215	14	132	180 _{±6}	4	15
K613/K614	300 *	300	265	14	136	230 _{±6}	4	17
K713/K714	350 *	350	300	18	157	250 _{±6}	5	18
K813/K814	350	350	300	18	186	250 _{±6}	5	18
	400 *	400	350	18	186	300 _{±6}	5	20
	450	450	400	18	186	350 _{±6}	5	20
K913/K914	450 *	450	400	18	215	350 _{±6}	5	23
K1013/K1014	550	550	500	18	256	450 _{±6}	5	25

* This is the standard flange diameter. For other diameters, specify at the time of ordering.



IP69K Certification

IP69K Per DIN 40050 / Part 9

The goal of this test is to simulate pressure cleaning conditions on a plant floor. The high protection rating guarantees absolute ingress-resistance, even in applications subject to frequent cleaning processes, e.g. in the food industry.

Test Conditions

- Cycle = 30 seconds per position
- Water pressure ~ 8,000 - 10,000 kPa at $+(80 \pm 5)^{\circ}\text{C}$
- Flow 14 - 16 liters per minute through fan nozzle
- Spray angles 0° , 30° , 60° and 90°
- Distance of nozzle to test unit 100 - 150 mm
- Water Temperature 80°C
- Test unit on turntable (5 revolutions/minute)

TRIALON <i>Corporation</i>		<i>TEST REPORT</i>	
Test ID #: 25742 PO#: 88405 Date: 5/21/2010		Page 1 of 3	

Test Items: Gear Reducer
Date: 5/21/2010

Test Spec:

Test Sum:

Test Sum:

Prepa:

Draw:

Engin:

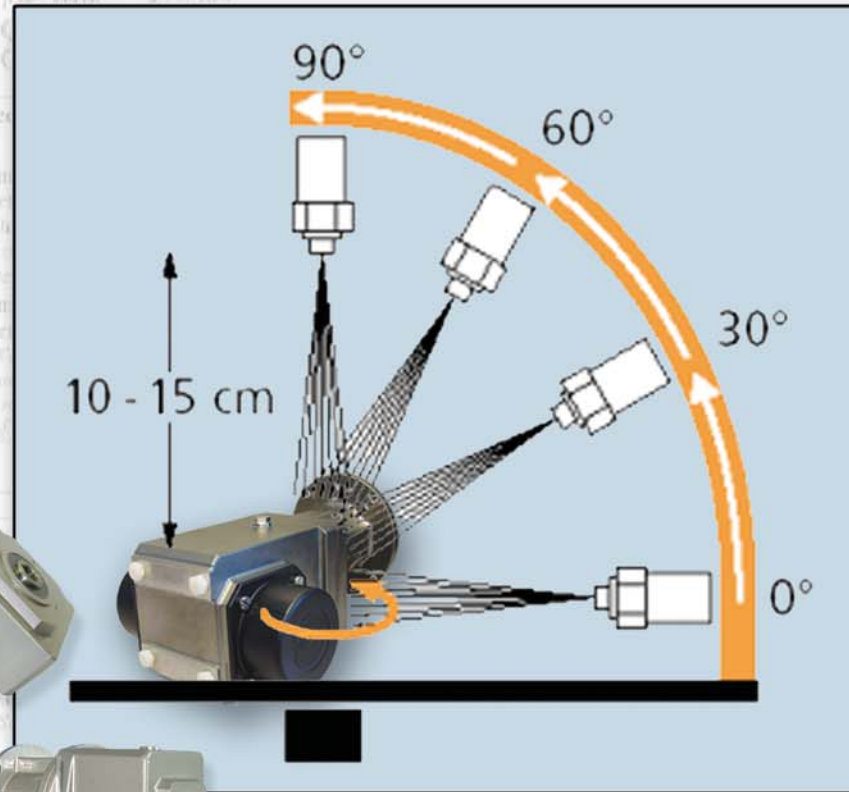

MIKE LUTZ
Laboratory Manager

ISO/IEC 17025
Accredited
Laboratory



Reliability Technical Center
1815 Tandy Pike
Kokomo, IN 46901
Ph: (765) 459-0590
Fax: (765) 459-0482
www.trialon.com

The test and measurement procedures used derived test results contained in this report relate only to the specific test item.
This test report and any inclusions or exclusions hereon are not the responsibility of the test item manufacturer or any other party.
STOBER received certification for KSS, K, F, and C Series reducers in 2010.



“KSS” Series – Right Angle Helical/Bevel Stainless Steel ServoFit® Modular System Features

STOBER Drives Inc. is proud to offer our quality-proven, high-efficiency “K” Series Helical/Bevel speed reducer in a stainless steel housing. The adaptability of the well known double wobble-free bushing, with expanded bore sizes, makes this unit necessary for the toughest washdown applications. The footprint is smaller (30% less) than the standard unit but the “KSS” uses the same high quality helical gearing which is case hardened to 58-62 Rockwell C and precision finished for low noise and long service life. The high efficiency (97%) assures reliability plus cost savings in energy and maintenance.

Performance Specifications:

- Torques up to 3,100 in.lbs. (350Nm)
- Output Bore Diameters up to 1 1/2 inch
- Ratios up to 178:1
- Totally Enclosed — no breather to allow contaminants in or oil out
- 304 Stainless Steel Housing
- 3 Year Warranty Standard
- Maintenance free — Lubricated for Life
- Application Specific Mounting Position
- Bushing allows mounting from either side
- Shipped filled with Mobile CIBUS SHC 220-H1 Food Grade Oil
- ALL Stainless Steel Hardware
- Laser Etched Nameplate Data

Gears Supported with Dual Bearings in one piece housing for structural rigidity

Stainless Steel Oil Fill Plug

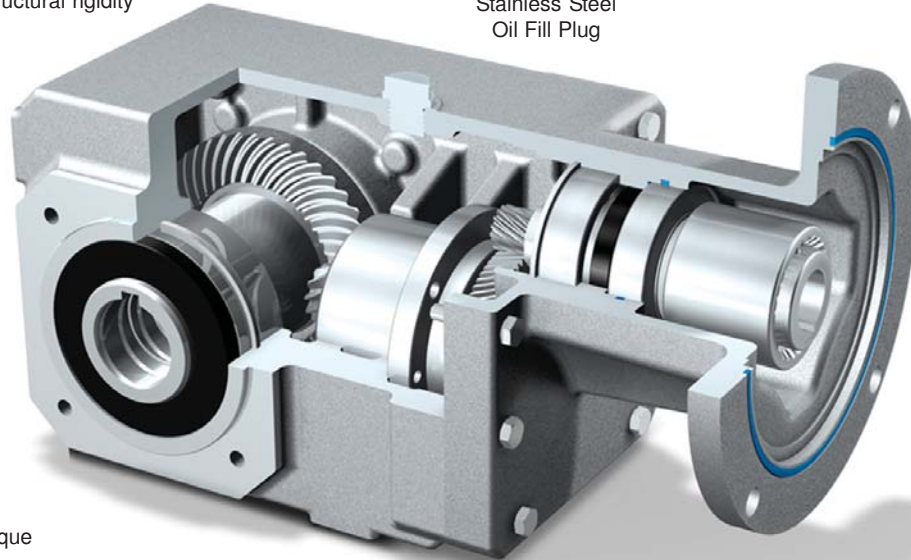

High efficiency spiral bevel gearing provides quiet operation and excellent torque carrying capacity

Double Sealed on Both Sides in one piece housing for structural rigidity

Nylon bolts on Side 1 (bottom) and Side 5 for protection during application assembly



Uses the patented (U.S. Patent Number 5,496,127) Stainless Steel Double Side Bushing mounted into stainless steel output quill — easily installs onto standard stainless steel shafting

IP69K









“KSS” Series – Right Angle Helical/Bevel Stainless Steel ServoFit® Modular System

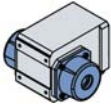

Part No. Explanation

KSS 3 0 2 W G 0100 MS3R E12

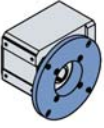
Series Size Generation No. of Gear Stages Output Style Housing Style Ratio:1 Motor Adapter Mounting Position Must be Specified

Series	KSS	Stainless Right Angle Helical/Bevel (output is at a right angle to input; gears are helical and spiral bevel; housing is stainless steel)
Size	3	Sizes available: KSS1, KSS2, KSS3
Generation	0	Design generation: first generation 0, second generation 1 , etc.
No. of Gear Stages	2	Number of gear stages: 2, 3 (determined by the ratio)
Output Style	W	Double wobble free bushing output 
	A	Hollow output 
	V	Shaft output  SPECIFY: Shaft Side 3 or Side 4.
Housing Style	G	Tapped holes around the output 
	F	Output flange  SPECIFY: Flange Side 3 or Side 4 (shown).
	N	Foot mounting  SPECIFY: Feet Side 1 (shown) or Side 5.
Ratio	0100	Approximate ratio: 0350 = 10.135:1 (4:1 up to 179:1)
Motor Adapter	MS3R	Motor adapter to fit unit size and motor: MS1R, MS2R, MS3R (Motor information must be specified.)
Mounting Position	E12	Mounting position must be specified.

K
S
S

IP69K



“KSS” Series – Right Angle Helical/Bevel Stainless Steel ServoFit® Modular System

Mounting Positions – Standard 3 Year Warranty

Mounting Position **MUST BE SPECIFIED**

Standard Oil: Food Grade (Mobil SHC CIBUS 220)
Optional Oil: Mobilgear 600XP220 or Synthetic Oil (Mobil SHC630)

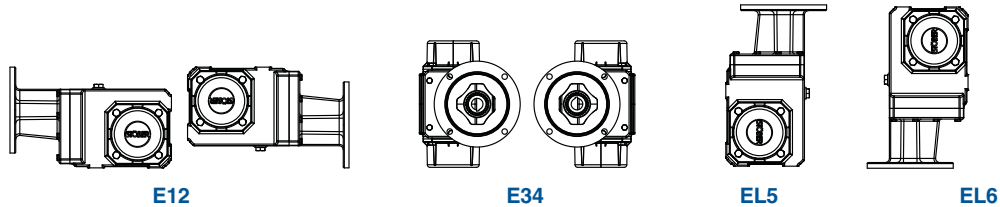

- E12** Side 1 or side 2 can be the down side with this mounting position.
- E34** Side 3 or side 4 can be the down side with this mounting position.
- EL5** Side 5 is the side opposite the motor. Side 5 is the down side for EL5.
- EL6** Side 6 is the input or motor side. Side 6 is the down side for EL6.

DO NOT MOUNT any STOBER reducer in a position other than specified on the order.

All STOBER units are filled with the correct amount of lubrication before shipping. In order to provide the proper lubrication quantity **the mounting position must be specified at the time the unit is ordered.**

For oil quantity in each size and mounting position, see our web site: <http://www.stober.com/pages/lubrication-quantity>.

Motor Mounting Specifications

STOBER servo gearheads will fit the motor of your choice by assembling a motor mounting plate between the motor and the gearhead. **When ordering a gearhead, specify the motor manufacturer and part number, provide the motor drawing with dimensions, or specify the motor mounting dimensions.** The motor plate thickness (L⁹) is determined by the motor shaft length. For a precise dimension on a specific motor, contact STOBER Technical Support.

The following dimensions are required to provide the correct motor mounting plate:

1. D⁶ Shaft Diameter (If an adapter bushing is required it will be supplied with the motor plate.)
2. D⁷ Pilot Diameter
3. D⁸ Bolt Circle Diameter
4. D⁹ Bolt Diameter
5. L¹¹ Motor Shaft Length
6. L¹² Pilot Length
7. L¹⁴ Square Flange (Optional — Motor plate will typically be made to match.)

Maintenance

With STOBER reducers very little maintenance is required under normal operating conditions. Units supplied without breathers are lubricated for life and maintenance free.

SHIPS in 1 DAY



Style AG
Hollow Output
Tapped Holes

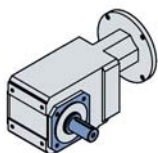

Style VG
Solid Output
Tapped Holes

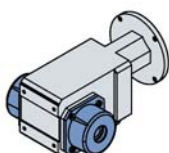

Style WG
Bushing
Tapped Holes

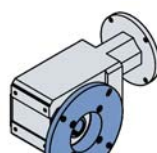

Style AF
Hollow Output
Flange Mount

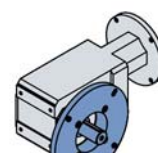

Style VF
Solid Output
Flange Mount

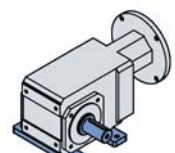

Style VN
Solid Output
Foot Mount

K
S
S



"KSS" Series—Right Angle Helical/Bevel Stainless Steel ServoFit® Modular System Selection Data



Part Number	Reducer Ratio i		Input RPM			Backlash arcmin $\Delta\phi$ ¹⁾	Input Inertia J ₁ kgcm ²	Torsional Stiffness per arcmin C ₂		Output Torque					
			Maximum					Nominal ¹⁾		Acceleration		Peak ²⁾			
	Nom.		Exact		M _{2N} ≤ 2000 RPM			M _{2B}		M _{2PEAK}					
	n _{1DBH}	n _{1DBV}	n _{1ZB}	in.lbs.	Nm			in.lbs.	Nm	in.lbs.	Nm				
KSS102 with Motor Adapter															
Noise Level ≤ 53 dB(A) ³⁾															
KSS102_0040 MS1R	4.000	4/1	3,300	2,800	4,500	12	1.4	25	2.8	368	42	368	42	460	52
KSS102_0056 MS1R	5.568	1520/273	3,300	2,800	4,500	12	1.3	38	4.3	512	58	512	58	640	72
KSS102_0060 MS1R	6.000	6/1	3,300	2,800	4,500	12	1.1	30	3.4	523	59	523	59	654	74
KSS102_0066 MS1R	6.644	299/45	3,600	3,300	5,000	12	1.0	31	3.5	570	64	570	64	712	80
KSS102_0083 MS1R	8.309	1911/230	3,600	3,300	5,000	12	0.9	33	3.7	654	74	684	77	855	97
KSS102_0092 MS1R	9.249	1748/189	3,600	3,300	5,000	12	0.9	46	5.2	678	76	793	90	991	112
KSS102_0100 MS1R	10.14	507/50	4,000	3,800	5,500	12	0.8	34	3.8	699	79	806	91	1,008	114
KSS102_0115 MS1R	11.57	266/23	3,600	3,300	5,000	12	0.8	48	5.4	730	82	952	108	1,190	134
KSS102_0125 MS1R	12.62	429/34	4,000	3,800	5,500	12	0.7	34	3.9	751	85	963	109	1,204	136
KSS102_0140 MS1R	14.11	494/35	4,000	3,800	5,500	12	0.8	49	5.5	780	88	1,122	127	1,403	158
KSS102_0165 MS1R	16.71	117/7	4,000	4,000	6,000	12	0.7	35	4.0	825	93	1,107	125	1,520	172
KSS102_0175 MS1R	17.56	2090/119	4,000	3,800	5,500	12	0.7	50	5.6	839	95	1,196	135	1,676	189
KSS102_0200 MS1R	20.15	403/20	4,000	4,000	6,000	12	0.7	35	4.0	878	99	1,107	125	1,763	199
KSS102_0230 MS1R	23.27	1140/49	4,000	4,000	6,000	12	0.7	51	5.7	921	104	1,196	135	2,115	239
KSS102_0250 MS1R	25.22	1261/50	4,000	4,000	6,000	12	0.6	36	4.0	851	96	1,021	115	1,701	192
KSS102_0280 MS1R	28.05	589/21	4,000	4,000	6,000	12	0.7	51	5.7	981	111	1,196	135	2,126	240
KSS102_0340 MS1R	33.71	4719/140	4,000	4,000	6,000	12	0.6	36	4.0	647	73	776	88	1,293	146
KSS102_0350 MS1R	35.11	3686/105	4,000	4,000	6,000	12	0.6	51	5.8	1,057	119	1,196	135	2,126	240
KSS102_0400 MS1R	40.30	403/10	4,000	4,000	6,000	12	0.6	36	4.1	544	61	653	74	846	96
KSS102_0470 MS1R	46.92	2299/49	4,000	4,000	6,000	12	0.6	51	5.8	900	102	1,080	122	1,800	203
KSS102_0500 MS1R	50.31	5031/100	4,000	4,000	6,000	12	0.6	36	4.1	442	50	531	60	885	100
KSS102_0560 MS1R	56.10	1178/21	4,000	4,000	6,000	12	0.6	51	5.8	758	86	909	103	1,178	133
KSS102_0700 MS1R	70.03	2451/35	4,000	4,000	6,000	12	0.6	51	5.8	616	70	739	83	1,232	139
KSS202 with Motor Adapter															
Noise Level ≤ 53 dB(A) ³⁾															
KSS202_0040 MS2R	4.000	4/1	3,000	2,600	4,000	10	3.7	35	3.9	915	103	1,512	171	2,170	245
KSS202_0044 MS2R	4.364	48/11	3,000	2,600	4,000	10	3.3	37	4.2	942	106	1,591	180	2,327	263
KSS202_0052 MS2R	5.177	2107/407	3,000	2,600	4,000	10	2.9	42	4.7	997	113	1,684	190	2,724	308
KSS202_0060 MS2R	6.000	6/1	3,000	2,600	4,000	10	2.9	53	5.9	1,047	118	1,769	200	3,199	361
KSS202_0067 MS2R	6.683	2279/341	3,500	3,100	4,500	10	2.3	47	5.3	1,086	123	1,834	207	3,364	380
KSS202_0071 MS2R	7.118	2107/296	3,000	2,600	4,000	10	2.6	57	6.4	1,109	125	1,873	211	3,543	400
KSS202_0084 MS2R	8.397	2494/297	3,500	3,100	4,500	10	2.0	51	5.7	1,171	132	1,949	220	3,543	400
KSS202_0092 MS2R	9.190	2279/248	3,500	3,100	4,500	10	2.1	62	7.0	1,207	136	1,949	220	3,543	400
KSS202_0100 MS2R	10.07	2881/286	3,500	3,500	5,000	10	1.8	53	6.0	1,245	141	1,949	220	3,543	400
KSS202_0115 MS2R	11.55	1247/108	3,500	3,100	4,500	10	1.9	66	7.4	1,303	147	1,949	220	3,543	400
KSS202_0125 MS2R	12.71	559/44	3,500	3,500	5,000	10	1.6	55	6.2	1,345	152	1,949	220	3,543	400
KSS202_0140 MS2R	13.85	2881/208	3,500	3,500	5,000	10	1.7	67	7.6	1,384	156	1,949	220	3,543	400
KSS202_0170 MS2R	16.86	2967/176	3,500	3,500	5,000	10	1.5	57	6.4	1,478	167	1,949	220	3,543	400
KSS202_0175 MS2R	17.47	559/32	3,500	3,500	5,000	10	1.6	69	7.8	1,495	169	1,949	220	3,543	400
KSS202_0200 MS2R	20.33	1118/55	3,500	3,500	5,000	10	1.4	57	6.5	1,573	178	1,949	220	3,541	400
KSS202_0230 MS2R	23.18	2967/128	3,500	3,500	5,000	10	1.4	70	7.9	1,643	186	1,949	220	3,543	400
KSS202_0250 MS2R	25.13	1935/77	3,500	3,500	5,000	10	1.3	58	6.5	1,688	191	1,949	220	3,543	400
KSS202_0280 MS2R	27.95	559/20	3,500	3,500	5,000	10	1.4	71	8.0	1,749	197	1,949	220	3,543	400
KSS202_0340 MS2R	33.62	1849/55	3,500	3,500	5,000	10	1.3	58	6.6	1,364	154	1,637	185	2,729	308
KSS202_0350 MS2R	34.55	1935/56	3,500	3,500	5,000	10	1.3	71	8.1	1,772	200	1,949	220	3,543	400
KSS202_0460 MS2R	46.23	1849/40	3,500	3,500	5,000	10	1.3	72	8.1	1,772	200	1,949	220	3,543	400

KSS

Max. Motor Shaft

Adapter	Diameter
MS1R	19
MS2R	24
MS3R	38

- Maximum torque for continuous input RPM - horizontal output position.
- Maximum momentary torque for emergency stops or heavy shock load. Admissible stops per life of reducer = 1,000 stops maximum.
- dB(A) Measured at 1 meter distance with 3000 RPM input



"KSS" Series—Right Angle Helical/Bevel Stainless Steel ServoFit® Modular System Selection Data



Part Number	Reducer Ratio i		Input RPM			Backlash arcmins $\Delta\phi$ ¹⁾	Input Inertia J ₁ kgcm ²	Torsional Stiffness per arcmin		Output Torque					
			Maximum					C ₂ in.lbs. Nm	Nominal ¹⁾		Acceleration		Peak ²⁾		
	Nom.	Exact	n _{1DBH}	n _{1DBV}	n _{1ZB}	M _{2N} ≤ 2000 RPM			M _{2B}		M _{2PEAK}				
						Continuous	Cyclic	in.lbs.	Nm	in.lbs.	Nm	in.lbs.	Nm		
KSS302 with Motor Adapter															
Noise Level ≤ 53 dB(A) ³⁾															
KSS302_0040 MS3R	4.000	4/1	2,700	2,300	3,800	10	6.4	40	4.5	1,375	155	1,512	171	2,238	253
KSS302_0044 MS3R	4.364	48/11	2,700	2,300	3,800	10	5.7	43	4.9	1,500	169	1,650	186	2,421	273
KSS302_0054 MS3R	5.375	43/8	2,700	2,300	3,800	10	4.5	51	5.7	1,768	200	2,032	229	2,884	326
KSS302_0060 MS3R	6.000	6/1	2,700	2,300	3,800	10	4.8	59	6.7	1,834	207	2,268	256	3,328	376
KSS302_0067 MS3R	6.740	2150/319	3,200	2,800	4,200	10	3.5	57	6.5	1,907	215	2,548	288	3,515	397
KSS302_0074 MS3R	7.391	473/64	2,700	2,300	3,800	10	3.9	66	7.5	1,966	222	2,794	315	3,965	448
KSS302_0084 MS3R	8.444	2322/275	3,200	2,800	4,200	10	2.8	63	7.1	2,056	232	3,192	360	4,244	479
KSS302_0093 MS3R	9.267	1075/116	3,200	2,800	4,200	10	3.2	72	8.2	2,120	239	3,410	385	4,833	546
KSS302_0100 MS3R	10.14	3010/297	3,500	3,100	5,000	10	2.4	66	7.4	2,185	247	3,410	385	4,911	554
KSS302_0115 MS3R	11.61	1161/100	3,200	2,800	4,200	10	2.6	77	8.6	2,286	258	3,410	385	5,835	659
KSS302_0125 MS3R	12.58	3182/253	3,500	3,100	5,000	10	2.1	69	7.8	2,348	265	3,410	385	5,854	661
KSS302_0140 MS3R	13.94	1505/108	3,500	3,100	5,000	10	2.3	79	8.9	2,429	274	3,410	385	6,201	700
KSS302_0170 MS3R	16.94	559/33	3,500	3,500	5,000	10	1.7	71	8.1	2,592	293	3,410	385	6,201	700
KSS302_0175 MS3R	17.29	1591/92	3,500	3,100	5,000	10	2.0	81	9.2	2,610	295	3,410	385	6,201	700
KSS302_0200 MS3R	20.28	3569/176	3,500	3,500	5,000	10	1.6	72	8.2	2,753	311	3,410	385	6,201	700
KSS302_0230 MS3R	23.29	559/24	3,500	3,500	5,000	10	1.7	83	9.4	2,883	325	3,410	385	6,201	700
KSS302_0250 MS3R	25.26	3612/143	3,500	3,500	5,000	10	1.5	73	8.3	2,962	334	3,410	385	4,328	489
KSS302_0280 MS3R	27.88	3569/128	3,500	3,500	5,000	10	1.6	84	9.5	3,061	346	3,410	385	6,201	700
KSS302_0340 MS3R	33.62	1849/55	3,500	3,500	5,000	10	1.4	74	8.3	2,217	250	2,660	300	4,434	501
KSS302_0350 MS3R	34.73	903/26	3,500	3,500	5,000	10	1.5	84	9.5	3,100	350	3,410	385	5,951	672
KSS302_0410 MS3R	40.51	4902/121	3,500	3,500	5,000	10	1.3	74	8.4	1,705	193	2,046	231	3,334	376
KSS302_0460 MS3R	46.23	1849/40	3,500	3,500	5,000	10	1.4	85	9.6	3,048	344	3,410	385	6,097	688
KSS302_0560 MS3R	55.71	2451/44	3,500	3,500	5,000	10	1.3	85	9.6	2,345	265	2,814	318	4,584	517

Index of Symbols: MS1R—Motor adapter, Stainless steel, to fit the KSS1 housing, with a Round flange.



See Page 282 for Options and Part Number Configuration.

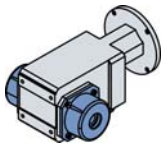

ServoFit® "KSS" Series – Stainless Steel Right Angle Helical/Bevel Tapped Hole – "G" Housing – Double Bushing

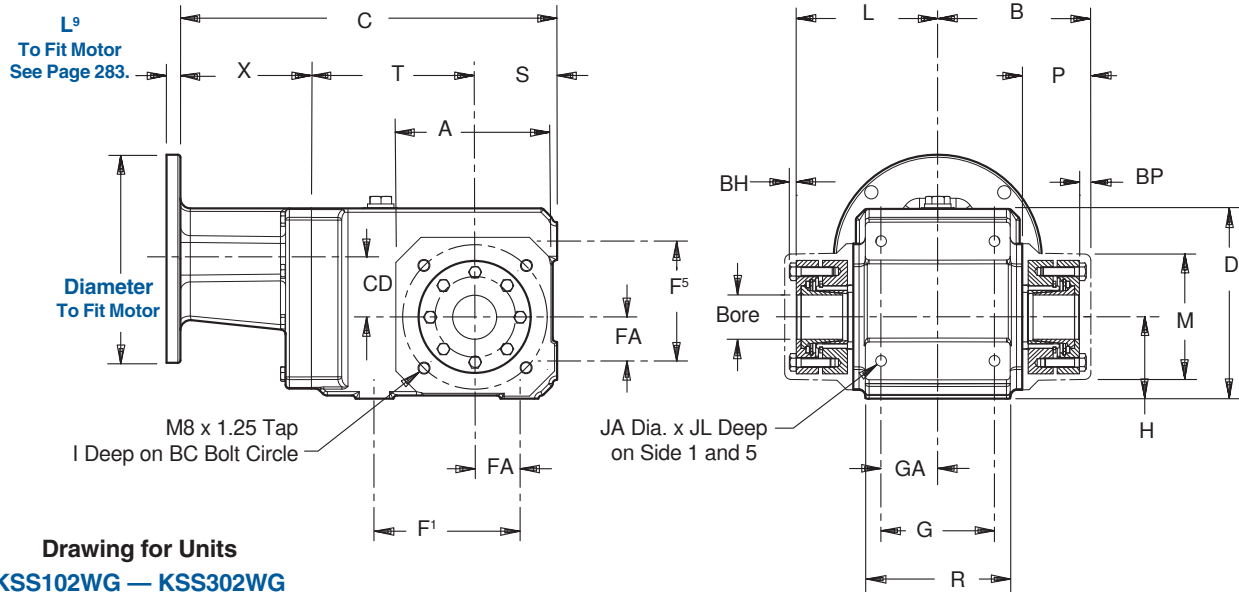

Table No. 1 "KSS" Series – Double Wobble Free Bushing – Dimensions (mm)

Unit with Motor Adapter	A	B	C	D	F ¹	F ⁵	G	H	I	L	M	P	R
KSS102WG_MS1R	115	103	256.5	126	90	75	70	60	13	93	78	50	90
KSS202WG_MS2R	126	120	299	151	115	95	90	60	13	109	99.5	53	112
KSS302WG_MS3R	132	126.5	327.5	166.5	130	105	105	75	14	115	96	53	140

Table No. 2 "KSS" Series – Double Wobble Free Bushing – Dimensions (mm)

Unit with Motor Adapter	S	T	X	BC	BP	BH	CD	FA	GA	JA	JL	Wt. lbs.
KSS102WG_MS1R	60	111	85.5	90	10	4	36	30	35	M8 x 1.25	13	29
KSS202WG_MS2R	65	130	104	115	11	4	46	35	45	M10 x 1.50	16	40
KSS302WG_MS3R	75	150	102.5	115	11	4	53	35	53	M10 x 1.50	16	55

Table No. 3 "WFBSS" Double Side Bushings – Inches

Unit	Stock Bore Sizes					
	1	1 ³ / ₁₆	1 ¹ / ₄	1 ³ / ₈	1 ⁷ / ₁₆	1 ¹ / ₂
KSS1	WFBSS1-100	—	—	—	—	—
KSS2	WFBSS2-100	WFBSS2-103	WFBSS2-104	WFBSS2-106	WFBSS2-107	WFBSS2-108
KSS3	WFBSS3-100	WFBSS3-103	WFBSS3-104	WFBSS3-106	WFBSS3-107	WFBSS3-108

Table No. 4

"WFBSS" – Double Side Bushings – Metric

Unit	Stock Bore Sizes — mm		
	25	30	35
KSS1	WFBSS1-25	—	—
KSS2	—	WFBSS2-30	WFBSS2-35
KSS3	—	WFBSS2-30	WFBSS2-35

All weights are approximate.

Part No. Example

Stainless Steel Unit with Motor Adapter
and 1⁷/₁₆ Bushing Bore

KSS202WG0100 MS2R
WFBSS2-107



ServoFit® "KSS" Series – Stainless Steel Right Angle Helical/Bevel Tapped Hole – "G" Housing – Hollow Output

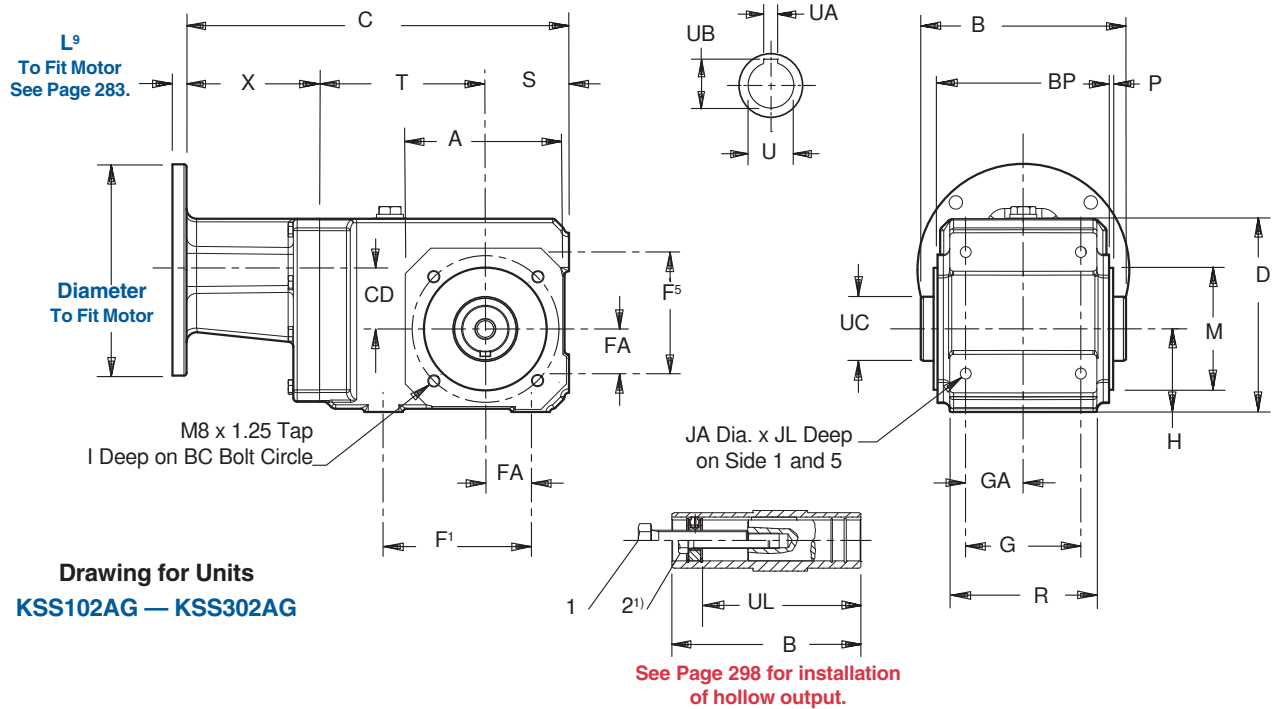

Table No. 1 "KSS" Series – Hollow Output – Dimensions (mm)

Unit with Motor Adapter	A	B	C	D	F ¹	F ⁵	G	H	I	M	P	R	S
KSS102AG_MS1R	115	120	256.5	126	90	75	70	60	13	78	3	90	60
KSS202AG_MS2R	126	148	299	151	115	95	90	60	13	95	3	112	65
KSS302AG_MS3R	132	160	327.5	166.5	130	105	105	75	14	95	3	140	75

Table No. 2 "KSS" Series – Hollow Output – Dimensions (mm)

Unit with Motor Adapter	T	X	BC	BP	CD	FA	GA	JA	JL	UC	UL	Wt. lbs.
KSS102AG_MS1R	111	85.5	90	106	36	30	35	M8 x 1.25	13	40	98	29
KSS202AG_MS2R	130	104	115	134	46	35	45	M10 x 1.50	16	50	113	40
KSS302AG_MS3R	150	102.5	115	146	53	35	53	M10 x 1.50	16	50	125	55

Table No. 3 Standard Bore – Inches

Base Module	U	UA	UB	1
KSS102	1.000	.250	1.11	1/2-13
KSS202	1.250	.250	1.37	5/8-11
KSS302	1.375	.312	1.52	5/8-11

Part No. Example
Hollow Bore Stainless Steel Unit
with Motor Adapter
KSS202AG0100 MS2R

¹Removal bolt, supplied by customer, must be smaller than mounting bolt. See Page 298.
All weights are approximate.



See Page 282 for Options and Part Number Configuration.



ServoFit® "KSS" Series – Stainless Steel Right Angle Helical/Bevel Tapped Hole – "G" Housing – Shaft Output

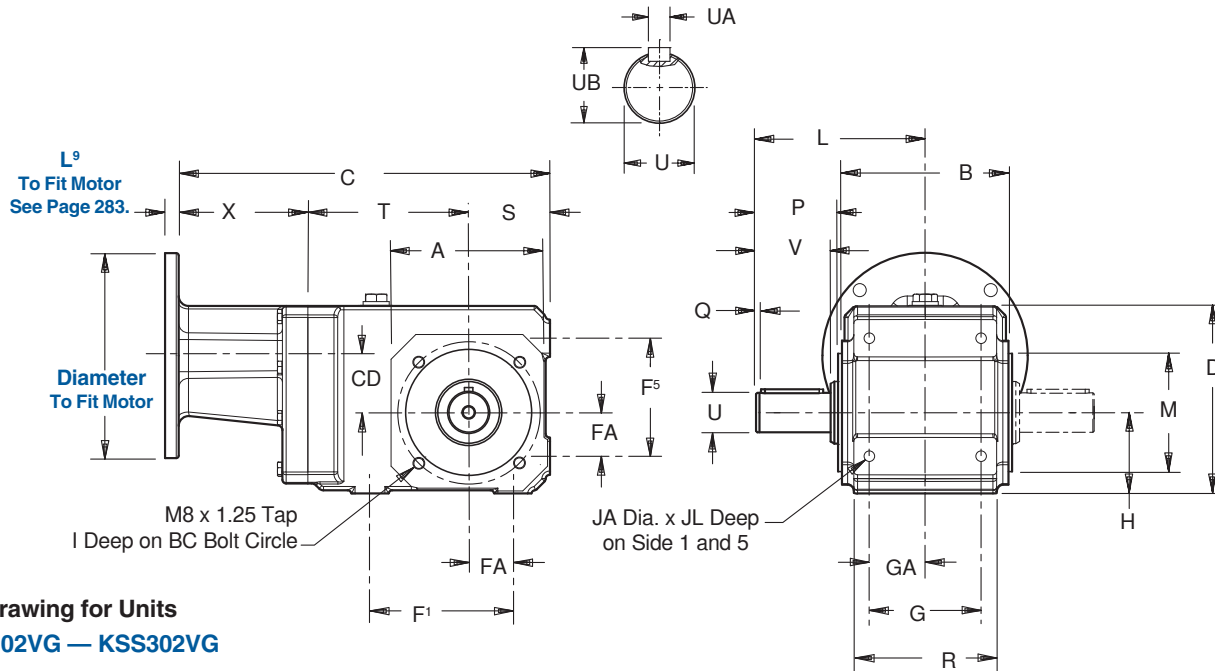

Table No. 1 "KSS" Series – Shaft Output – Dimensions (mm)

Unit with Motor Adapter	A	B	C	D	F ¹	F ⁵	G	H	I	L	M	P	Q	R
KSS102VG_MS1R	115	120	256.5	126	90	75	70	60	13	115	78	59	4	90
KSS202VG_MS2R	126	148	299	151	115	95	90	60	13	136	95	66	4	112
KSS302VG_MS3R	132	160	327.5	166.5	130	105	105	75	14	142	95	66	4	140

Table No. 2 "KSS" Series – Shaft Output – Dimensions (mm)

Unit with Motor Adapter	S	T	V	X	BC	CD	FA	GA	JA	JL	Wt. lbs.
KSS102VG_MS1R	60	111	50	85.5	90	36	30	35	M8 x 1.25	13	29
KSS202VG_MS2R	65	130	60	104	115	46	35	45	M10 x 1.50	16	40
KSS302VG_MS3R	75	150	60	102.5	115	53	35	53	M10 x 1.50	16	55

Table No. 3 Standard Shaft – Inches

Base Module	U	UA - Key	UB
KSS102	1.000	1/4x1/4x1 ⁹ / ₁₆	1.11
KSS202	1.250	1/4x1/4x1 ¹⁵ / ₁₆	1.36
KSS302	1.250	1/4x1/4x1 ¹⁵ / ₁₆	1.36

Part No. Example
Solid Shaft Stainless Steel Unit
with Motor Adapter

KSS202VG0100 MS2R
(Shaft shown on Side 3)

IP69K



ServoFit® "KSS" Series – Stainless Steel Right Angle Helical/Bevel Foot Mount – "N" Housing – Shaft Output

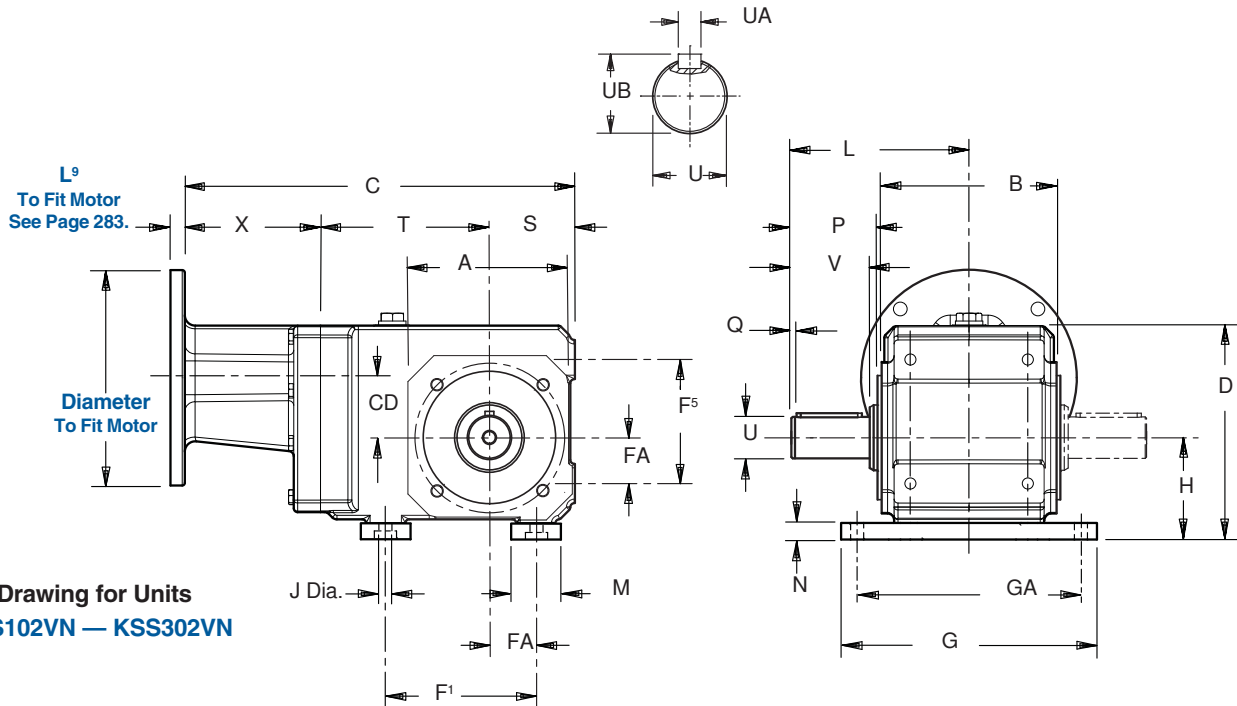
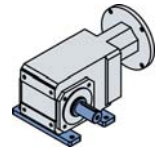

Table No. 1 "KSS" Series – Shaft Output – Dimensions (mm)

Unit with Motor Adapter	A	B	C	D	F ¹	F ⁵	G	H	J	L	M	N	P	Q
KSS102VN_MS1R	115	120	256.5	126	90	75	140	60	8.4	115	38.1	12.7	59	4
KSS202VN_MS2R	126	148	299	164	115	95	196	78	10	136	38.1	12.7	66	4
KSS302VN_MS3R	132	160	327.5	179.5	130	105	196	87.5	10	142	38.1	12.7	66	4

Table No. 2 "KSS" Series – Shaft Output – Dimensions (mm)

Unit with Motor Adapter	S	T	V	X	CD	FA	GA	Wt. lbs.
KSS102VN_MS1R050	60	111	50	85.5	36	30	115	29
KSS202VN_MS2R140	65	130	60	104	46	35	171	40
KSS302VN_MS3R140	75	150	60	102.5	53	35	171	55

Table No. 3 Standard Shaft – Inches

Base Module	U	UA - Key	UB
KSS102	1.000	1/4x1/4x1 ⁹ / ₁₆	1.11
KSS202	1.250	1/4x1/4x1 ¹⁵ / ₁₆	1.36
KSS302	1.250	1/4x1/4x1 ¹⁵ / ₁₆	1.36

Part No. Example

Solid Shaft, Foot Mounted, Stainless Steel Unit with Motor Adapter

KSS202VN0100 MS2R
(Shaft shown on Side 3)

K
S
S

IP69K

See Page 282 for Options and Part Number Configuration.

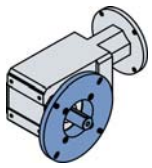

ServoFit® "KSS" Series – Stainless Steel Right Angle Helical/Bevel Flange Mount – "F" Housing – Shaft Output

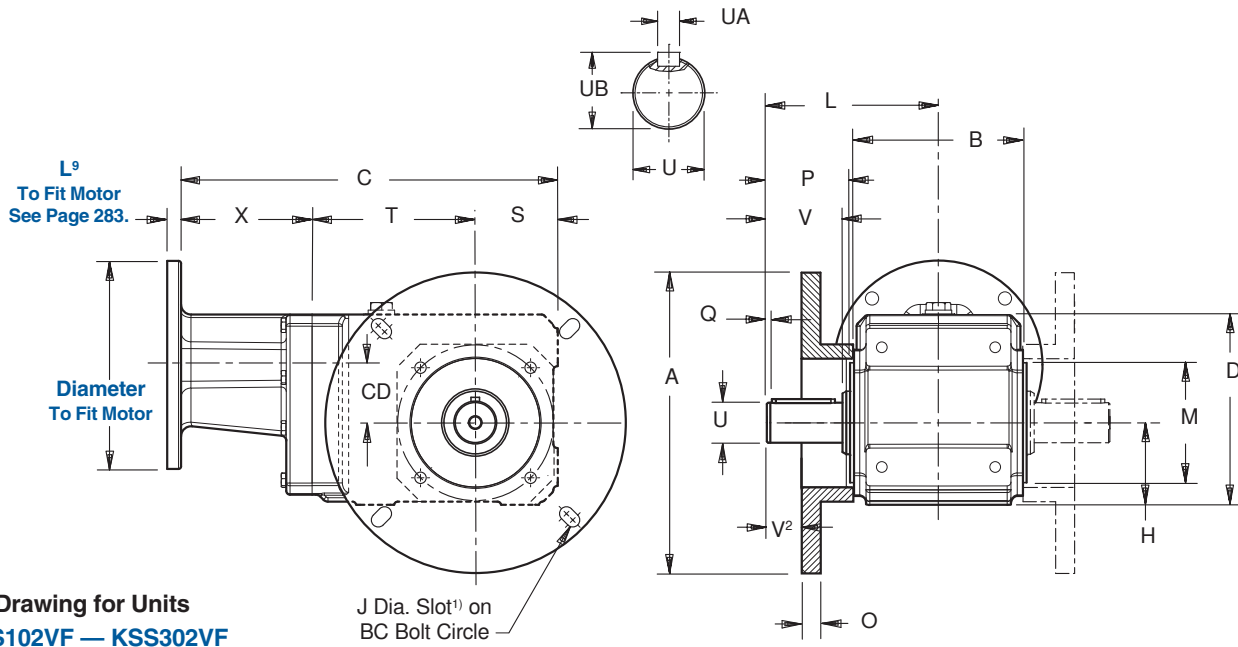

Drawing for Units
KSS102VF — KSS302VF

Table No. 1 "KSS" Series – Shaft Output – Dimensions (mm)

Unit with Motor Adapter	A	B	C	D	H	J ¹)	L	M	O	P	Q	S	T
KSS102VF_MS1R	171.5	120	256.5	126	60	8.5	115	78	14	59	4	60	111
KSS202VF_MS2R	222	148	299	151	60	10.5	136	95	14	66	4	65	130
KSS302VF_MS3R	222	160	327.5	166.5	75	10.5	142	95	14	66	4	75	150

Table No. 2 "KSS" Series – Shaft Output – Dimensions (mm)

Unit with Motor Adapter	V	V²	X	BC		CD	Wt. lbs.
				Min.	Max. ¹)		
KSS102VF_MS1R	50	20.5	82.5	149.2	—	36	29
KSS202VF_MS2R	60	28	104	190	203.2	46	40
KSS302VF_MS3R	60	28	102.5	190	203.2	53	55

Table No. 3 Standard Shaft – Inches

Base Module	U	UA - Key	UB
KSS102	1.000	1/4x1/4x1 ⁹ / ₁₆	1.11
KSS202	1.250	1/4x1/4x1 ¹⁵ / ₁₆	1.36
KSS302	1.250	1/4x1/4x1 ¹⁵ / ₁₆	1.36

¹) KSS1 mounting bolt hole is not a slot.
All weights are approximate.

Part No. Example
Solid Shaft, Flange Mounted Stainless Steel Unit
with Motor Adapter

KSS202VF0100 MS2R140
(Flange and Shaft shown on Side 3)





ServoFit® "KSS" Series – Stainless Steel Right Angle Helical/Bevel Flange Mount – "F" Housing – Hollow Output

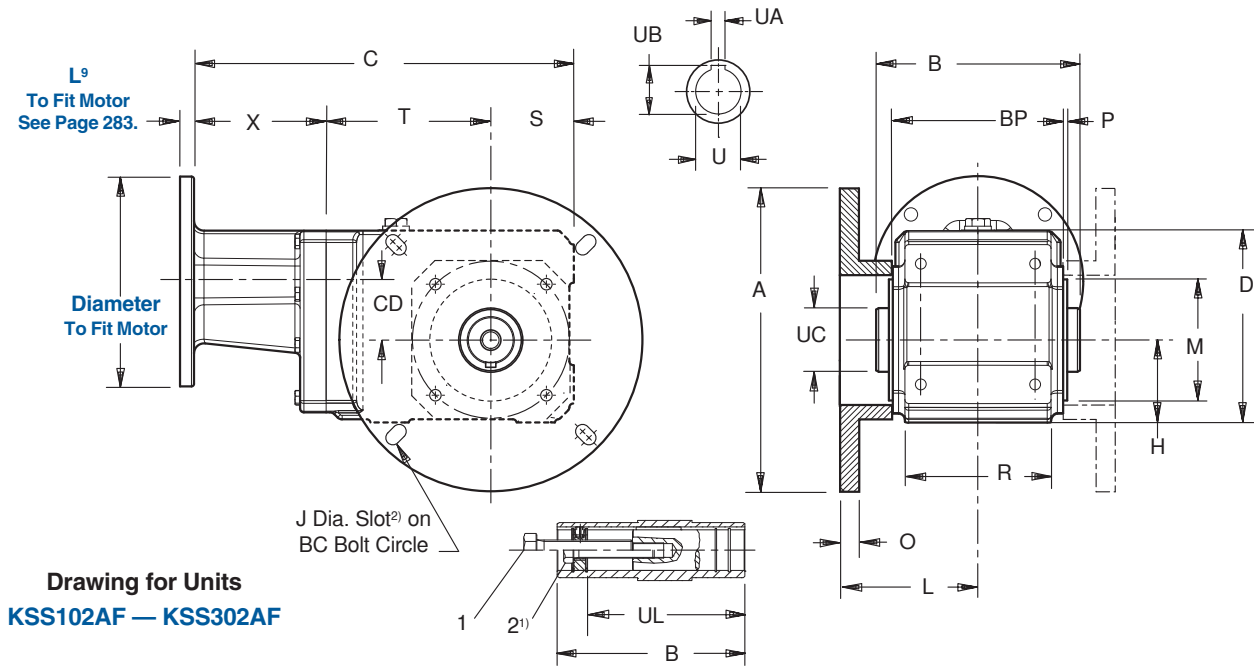
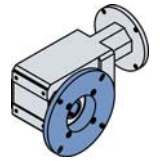

See Page 298 for installation of hollow output.

Table No. 1 "KSS" Series – Hollow Output – Dimensions (mm)

Unit with Motor Adapter	A	B	C	D	H	J ¹⁾	L	M	O	P	R	S	T	X
KSS102AF_MS1R	171.5	120	256.5	126	60	8.5	94.5	78	14	3	90	60	111	82.5
KSS202AF_MS2R	222	148	299	151	60	10.5	108	95	14	3	112	656	130	104
KSS302AF_MS3R	222	160	327.5	166.5	75	10.5	114	95	14	3	140	75	150	102.5

Table No. 2 "KSS" Series – Hollow Output – Dimensions (mm)

Unit with Motor Adapter	BC		BP	CD	UC	UL	Wt. lbs.
	Min.	Max. ¹⁾					
KSS102AF_MS1R	149.2	—	106	36	40	98	29
KSS202AF_MS2R	190	203.2	134	46	50	113	40
KSS302AF_MS3R	190	203.2	146	53	50	125	55

Table No. 3 Standard Bore – Inches

Base Module	U	UA	UB	1
KSS102	1.000	.250	1.11	1/2-13
KSS202	1.250	.250	1.37	5/8-11
KSS302	1.375	.312	1.52	5/8-11

Part No. Example
Hollow Bore, Flange Mounted Stainless Steel Unit
with Motor Adapter

KSS202AF0100 MS2R
(Flange shown on Side 3)

¹⁾Removal bolt, supplied by customer, must be smaller than mounting bolt. See Page 298.

²⁾KSS1 mounting bolt hole is not a slot.

All weights are approximate.

IP69K

See Page 282 for Options and Part Number Configuration.



ServoFit® Gearhead Motor Mounting Instructions



General Information

Servo motors are mounted to ServoFit® gearheads by using a TriAdapt® motor adapter with a clamp coupling or the FlexiAdapt® motor adapter with a bellows shaped thermal expansion feature. These patented adapters require no key but uses a friction locking triple split collet to clamp the shaft. A split bushing is included when the motor shaft is smaller than the input bore in the gearhead. The coupling operates free of backlash and, if installed correctly, requires no maintenance.

Tolerances for the motor must be ISO j6 on the pilot diameter and ISO k6 on the motor shaft, see Table No. 1. The motor shaft does not require a key but shaft runout, pilot concentricity and perpendicularity should meet DIN standard 42955-N when possible.

ISO metric threads are designated by the letter "M" followed by the nominal diameter and the pitch, separated by the "x" sign. Example: M6 x 0.75. (NOTE: The absence of the pitch number indicates course pitch by default.)

The pitch number for tapped holes on STOBER specifications are: M5 x 0.80, M6 x 1.00, M8 x 1.25, M10 x 1.50, M12 x 1.75, and M16 x 2.00.

Important: Clean the motor shaft with degreaser to remove any film of oil or grease.

Parts for ServoFit Modular System

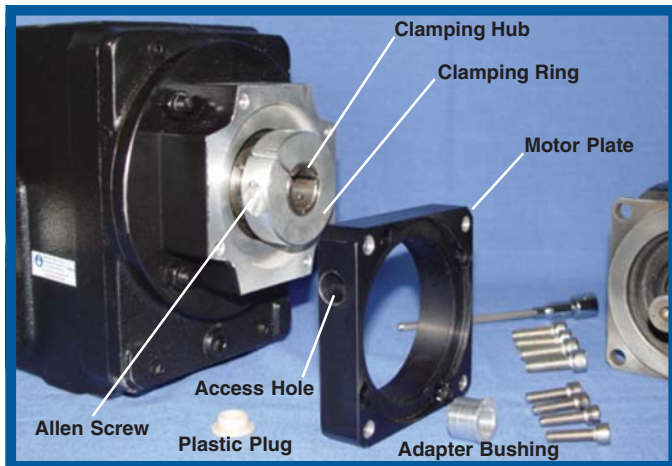

STEP 1. Remove the access hole plug.

Carefully remove the plastic plug from the access hole in the motor plate.

For new installations, the plastic plug, wrench, instructions, and bushing, when required, are contained in a plastic bag included in the shipping carton.

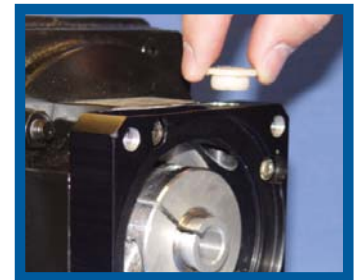

STEP 2. Align screw with access hole.



Visually align the access hole with the Allen screw in the clamping ring by turning the gearhead output shaft or the input coupling. (Shown with wrench for illustration purposes.)

Parts for ServoFit Precision Planetary Gearheads

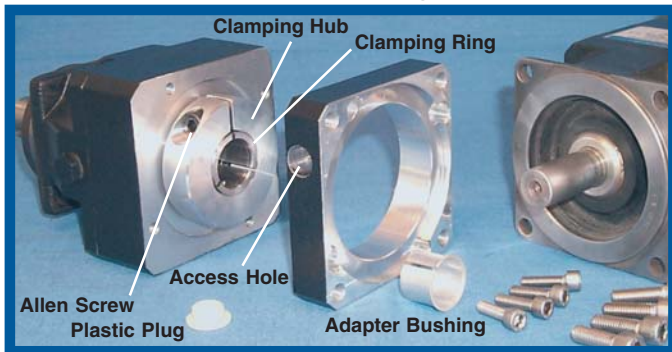

STEP 3. Install bushing (when applicable).

If an adapter bushing is needed, degrease the bushing inside and outside. Align the slot in the adapter bushing with the slot in the coupling hub. Slide the bushing into the input bore until the collar of the bushing touches the shaft end.

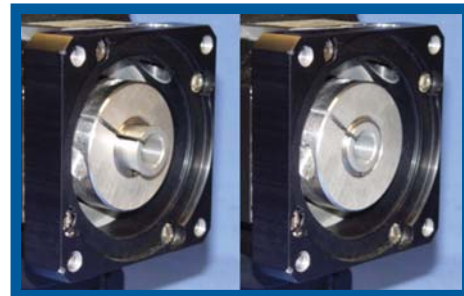

Table No. 1 Tolerances for Motors

k6 - Shaft Diameter	Metric (µm)
over 6 - 10	+10 / +1
over 10 - 18	+12 / +1
over 18 - 30	+15 / +2
over 30 - 50	+18 / +2
j6 - Pilot Diameter	Metric (µm)
over 10 - 18	+8 / -3
over 18 - 30	+9 / -4
over 30 - 50	+11 / -5
over 50 - 80	+12 / -7
over 80 - 120	+13 / -9
over 120 - 180	+14 / -11
over 180 - 250	+16 / -13
over 250 - 315	+16 / -16
over 315 - 400	+18 / -18

See web site for drawings.

STOBER Drives Inc. • ServoFit® 2011 • www.stober.com



ServoFit® Gearhead Motor Mounting Instructions



STEP 4. Carefully mount the motor.

Place the gearhead (with the bushing installed where necessary) onto the motor shaft. (If there is a keyway in the motor shaft, align the slot in the clamping hub with the keyway.) Support the gearhead while sliding it onto the motor shaft.

IT IS VERY IMPORTANT THAT THE GEARHEAD IS NOT FORCED ONTO THE SHAFT AND THE MOTOR IS CONCENTRIC WITH THE GEARHEAD COUPLING.

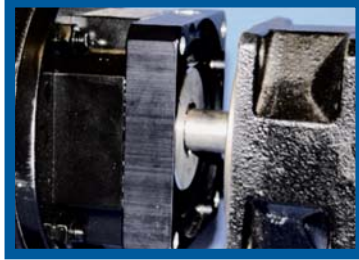

STEP 5. Bolt the motor to the motor plate.

Bolt the motor flange to the gearhead motor plate.

Tighten the motor bolts to the recommended tightening torque shown in Table No. 2.

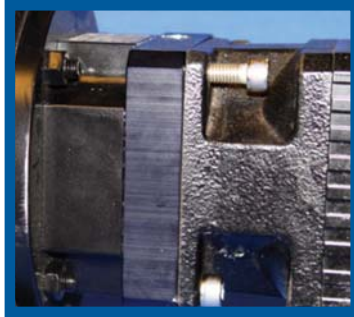

STEP 6. Tighten the TriAdapt coupling screw.

With a torque wrench, tighten the Allen screw on the coupling to the recommended torque shown in Table No. 2. A torque wrench extension is provided with each gearhead. If there are two (2) screws, be sure to tighten them equally.



STEP 7. Re-insert the plastic plug.

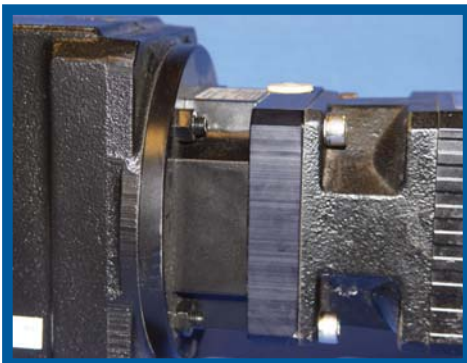

Table No. 2 Capscrew Tightening Torque

	Allen Wrench		Tightening Torque	
	Size	Nm.	in. lbs.	
Units with MT or MF Coupling				
P221, P222, P322, KS403	3	3	26.6	
P221L, P222L, P321, P322L, P422	5	10	88.5	
KS402, KS503	5	10	88.5	
P321L, P421, P422L, P522	6	25	221.3	
KS502, KS703	6	25	221.3	
P421L, P521, P522L, P722, KS702	6	25	221.3	
P521L, P721, P722L, P822	8	45	398.3	
P721L, P821, P822L, P922	10	60	531	
P821L, P921, P922L, PHQ1032	14	210	1,858.5	
Units with ME Coupling				
PA322	3	4.5	39.8	
PA321, PA422	4	9	35.4	
PA321L, PA421, PA522	5	16	141.6	
PA421L, PA521, PA522L, PA722	6	40	354.0	
PA521L, PA721, PA722L, PA822	8	75	663.8	
PA821, PA822L	10	130	1,150.5	
P221KX3, P321KX3, P422KX3	4	10	88.5	
P421KX4, P521KX5, P522KX4, P722KX5	5	14	123.9	
P721KX7, P822KX7	8	45	398.3	
P821KX8, P932KX8	10	60	531	
Units with PE Coupling				
PH322	3	3	26.6	
PH321, PH322L, PH422	5	10	88.5	
PH321L, PH421, PH422L, PH522, PHQ723	6	25	221.25	
PH421L, PH521, PH522L, PHQ722, PHQ823	6	25	221.3	
PH521L, PH721, PH722L, PH822, PHV933	8	45	398.3	
PHQ822, PHQ923	8	45	398.3	
PH821, PH932, PH1032, PHV1033	10	60	531	
PHQ922, PHQ1023	10	60	531	
Units with PH Coupling				
PHA322	3	4.5	39.8	
PHA321, PHA422	4	9	35.4	
PHA321L, PHA421, PHA522	5	16	141.6	
PHA421L, PHA521, PHA722	6	40	354.0	
PHA521L, PHA721, PHA822, PHVA933	8	75	663.8	
PHA821, PHA932, PHA1032, PHVA1033	10	130	1,150.5	
PH321KX3, PH422KX3	4	10	88.5	
PH421KX4, PH521KX5	5	14	123.9	
PH522KX4, PH722KX5	5	17	150.5	
PH721KX7, PH822KX7	8	35	309.8	
PH821KX8, PH932KX8	10	120	1062	
Units with PE Coupling				
PE2	4	10	88.5	
PE3	5	17	150.5	
PE4	6	42	371.7	
PE5	8	83	734.6	
Units with ME Coupling				
	3	4.5	40	
	4	9	80	
	5	16	142	
	6	40	354	
	8	75	664	
	10	130	1,150	
	14	310	2,744	
ServoFit Gearheads – "C", "F", or "K"				
MT10	5	10	88.5	
MT20	6	25	221.3	
MT30	8	45	398.3	
MT40	10	60	531	
MT50	14	210	1,858.5	



ServoFit® Modular System Shrink Ring Installation



Description of the Shrink Ring Connection

The gear unit hollow shaft is connected to a finished machine drive shaft by frictional engagement through compression of the shrink ring on the hollow shaft. This shaft-hub connection is totally free of backlash and when installed properly will also be wear-free. Because of its self-centering property, it can transmit high torques and axial thrusts with great accuracy. **CAUTION: DO NOT apply radial load to the shrink ring side.**

The hollow shaft is manufactured from heat-treated steel.

Dimensions for the machine driving shaft can be found on Pages 178, 234, 263, and 276. The hollow shafts will have a compression slot on some gearbox sizes depending on the shaft size and unit size.

If the hollow shaft has a slot at the shrink ring end **then** the machine shaft must have a tolerance of ISO h9.

If the hollow shaft does not have a slot at the shrink ring end **then** the machine shaft must have a tolerance of ISO h6.

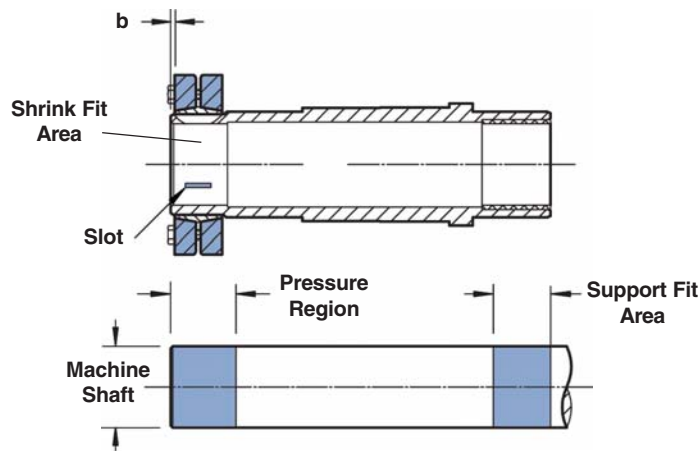

Assembly

Gear units supplied with a shrink ring, are shipped with the ring installed on the hollow shaft end, ready for assembly. The tapered surfaces and mounting bolts of the shrink ring are greased at the factory.

CAUTION: The clamping bolts on the shrink ring must never be tightened before the unit is mounted on the machine shaft. Tightening these bolts prematurely will damage the inner ring and hollow shaft during assembly.

STEP 1. Prepare hollow bore and machine shaft

- De-grease the machine shaft in the pressure region of the shrink ring.
- Remove closing and covering caps from hollow shaft and shrink ring.
- Clean shrink fit and support fit areas of the hollow shaft to remove any protective paint.

IMPORTANT: Hollow shaft bore and machine shaft must be free of grease in the region of the shrink fit!

STEP 2. Assembly sequence

Slide the gear unit onto the machine shaft and bring into position. **DO NOT FORCE THE UNIT OR USE A HAMMER.**

The shrink ring must be located at “b” dimension from the end of the shaft on units with a slotted hollow shaft. See Table 1.

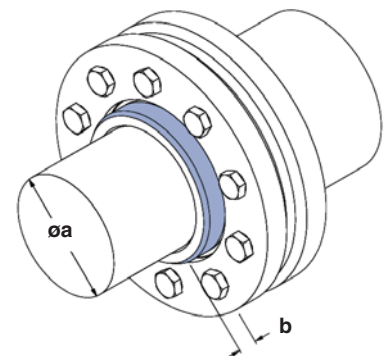

Table No. 1

Shaft Size - øa	20	25	30	35	40	50
Spacing - b	2	3	3	3	3	4



ServoFit® Modular System Shrink Ring Installation



Uniformly tighten the capscrews of the shrink ring in a rotating sequence. It will take several tightening rotations to do this correctly. Tighten the screws approximately ¼ to ½ turns each rotation, until all the screws are tightened. The final tightening should be done with a torque wrench to the torque shown in Table 2.

When the tightening is completed the space between each shrink ring must be absolutely equal distance (max. 0.2 mm) from one another. Measure the distance at several locations to assure the spacing is correct.

Table No. 2 Mounting Bolt Tightening Torque

Bolt Size	M5	M6	M8	M10	M12	M14
	8.8	10.9/12.9	10.9/12.9	10.9/12.9	10.9/12.9	12.9
Wrench size [mm]	8	10	13	16	18	21
Tightening torque [Nm] (at μ total = 0.1)	5	12/14	30/35	59/69	100/120	190

The tightening torque must correspond to the values in the table and be checked with a torque wrench.

STEP 3. Install cover.

Covers or any protective devices must be installed correctly before start-up of the drive.

Disassembly

WARNING: Protect the drive and personnel against unintentional powerup by following your companies “lock-out/tag-out” procedures.

Remove the covers on the shrink ring.

Loosen the screws of the shrink ring gradually in a rotating sequence. In order to prevent misalignment and damage to the ring, it will take more than one rotation to loosen the screws.

IMPORTANT: Do not loosen and remove the screws completely from the tapped holes. The shrink ring could spring off and cause bodily injury.

Once the screws and shrink rings have been loosened, the pressure between the hollow shaft and machine shaft should be released. If necessary, remove the shrink ring and put the snap ring into the groove to pull the drive off of the machine shaft.

If the shrink ring has to be cleaned, the screws and tapered surfaces must be relubricated using a MoS2-based grease before reinstallation.

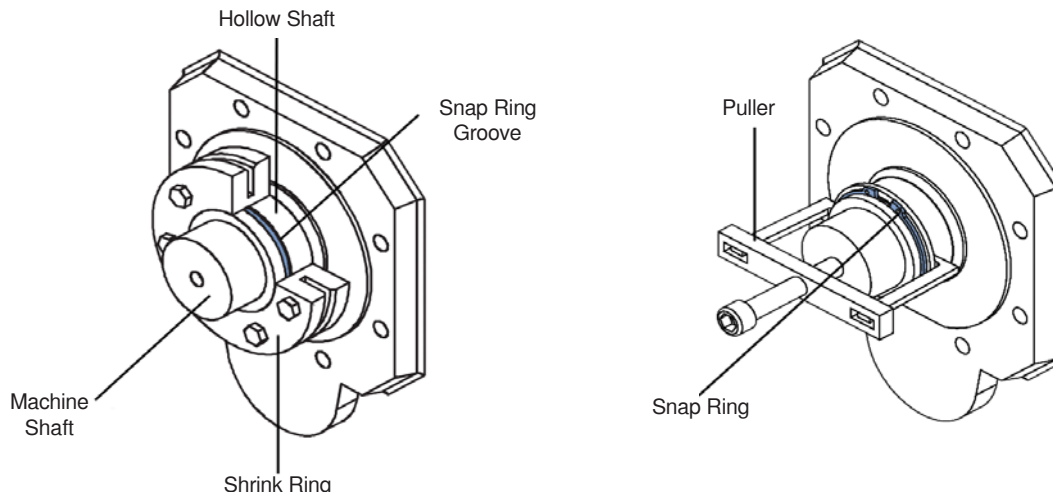



"K" Series – ServoFit® Modular System "WFB" Bushing Installation

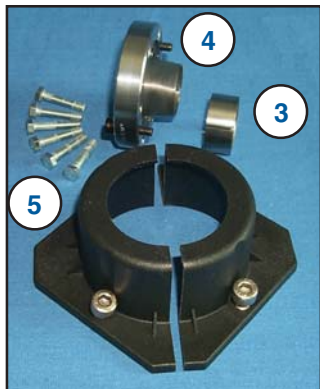

Support Side Bushing Components

The Support Side is the bushing with the dark coating on the cone. Do NOT use cleaner on the coated cone.

Support Side Installation



Insert Tapered Cone

K1 units do not have a tapered cone.



Install Flanged Cone Assembly

Install the Flanged Cone Assembly (4) with its slot opposite the slot in the tapered cone (3).



Hand Tighten Capscrews

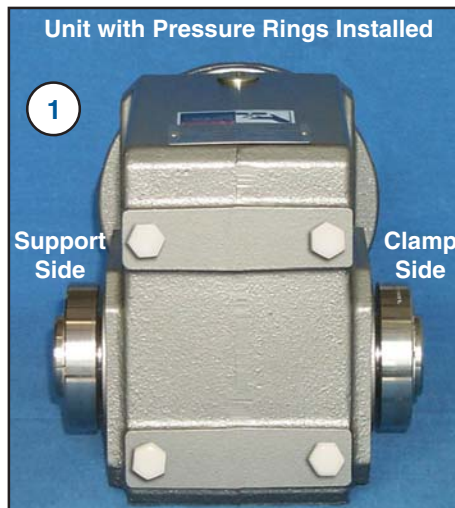

Unit with Pressure Rings Installed

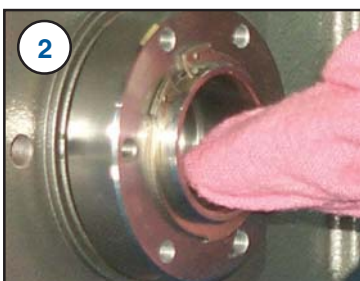

Be sure the inside of the quill is free of grease and oil before installing the tapered cones.

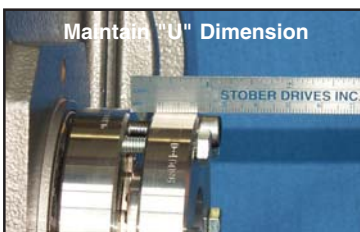

Maintain "U" Dimension

The "U" distance (between the rings) determined by the spacer bolts (see Table 1) must be maintained throughout assembly of the bushing and mounting onto the shaft. Therefore DO NOT tighten the capscrews or remove the spacer bolts until the unit is mounted on the shaft.



**VERY IMPORTANT
Do NOT Remove Spacer Bolts**

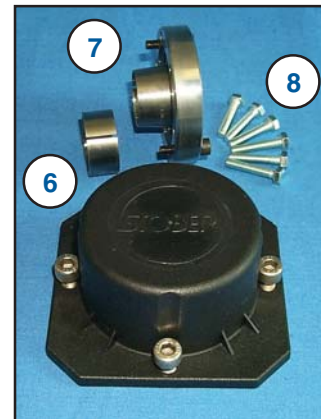

Clamp Side Bushing Components

Clamp Side Installation



Insert Tapered Cone

K1 units do not have a tapered cone.



Install Flanged Cone Assembly

Install the Flanged Cone Assembly (7) with its slot opposite the slot in the tapered cone (6).



Hand Tighten Capscrews



"K" Series – ServoFit® Modular System "WFB" Bushing Installation

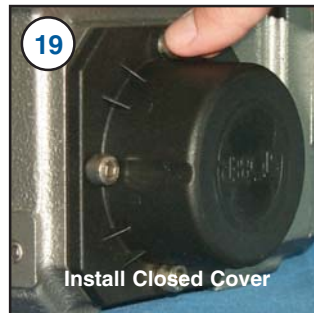
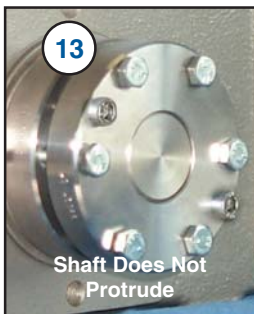

Tighten all capscrews to the torque shown in Table 1. Use a torque wrench. The tightening should be done gradually in a rotating sequence and will require more than one rotation.

After two hours (minimum) running time, check capscrews and retighten, if necessary.

Table No. 1

Base Module	Capscrews		Tightening Torque		U		Spacer Bolts
	Qty.	Size x Length	Nm.	in. lbs.	mm	ins.	
K102	6	M6x25 mm	10	89	5	.20	M6x20mm
K202/K203	6	M6x30 mm	10	89	5	.20	M6x20mm
K302/K303	8	M6x30 mm	10	89	5	.20	M6x20mm
K402/K403	8	M8x30 mm	25	221	6	.24	M8x20mm
K513/K514	8	M8x30 mm	25	221	7	.28	M8x25mm
K613/K614	8	M10x35 mm	49	434	8.5	.33	M10x25mm
K713/K714	8	M10x40 mm	49	434	5.5	.22	M10x25mm
K813/K814	8	M12x40 mm	85	752	7	.28	M12x45mm

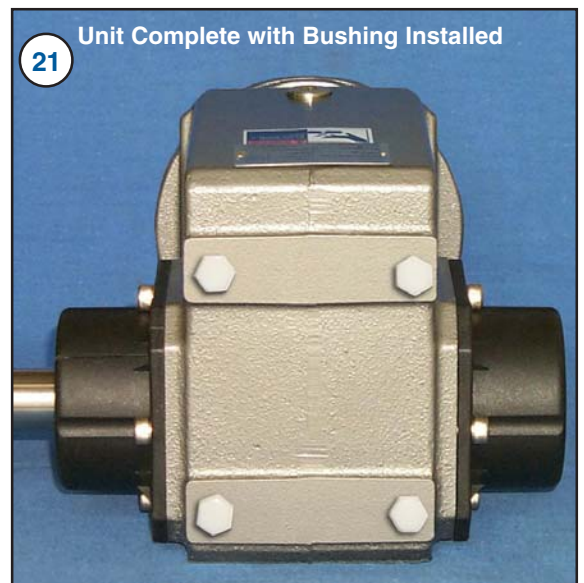



"No Key and Wobble Free"

The STOBER "Wobble Free" bushing is a unique patented⁽¹⁾ bushing system which can be supplied on a single side or double sides. These bushings can be mounted in the "F" Series and "K" Series ServoFit reducers. Each case size can be provided with a variety of bushing bores. The unit is selected based on horsepower or torque rating, output speed or ratio, and the shaft size of the driven equipment.

Some special features of the bushing system are:

- Featuring a distinct support side and a clamp side, the dual tapered cones will overcome a wide range of tolerances normally found with standard shaft materials. There is no shaft key necessary.
- Units sizes K102 through K814 can be supplied with output covers on one or both sides which protect the seals and also cover the rotating bushing. F102 through F603 can only have a cover mounted on Side 5.
- Wobble Free — tapered cones in conjunction with a support ring or support side bushing prevent the "rocking" of the reducer on the shaft, common with many bushing designs.
- The reducer output bore can be changed any time by changing the bushing kit.
- The bushing will accept a shaft with a tolerance of $+0.000/-0.005$ inches.
- **Important:** A $1/32 \times 45^\circ$ chamfer minimum is recommended for the shaft end.
- The quill, all bushing parts, and hardware can be supplied stainless steel to provide corrosion resistance for washdown applications.

Detailed instructions for mounting the bushing are included with each bushing kit.

Double Sided Bushing

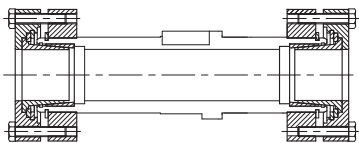

Support Side

Clamp Side

This unique design allows the unit to be mounted on the shaft from either side of the reducer by reversing the clamp side and support side bushings. The clamp side is determined by the customer but is usually the easily accessible outside bushing.

The double sided bushing is not installed into the unit at assembly, but with easy-to-follow installation instructions, the unit and bushing can be mounted on the machinery quickly — without any special tools.

Single Sided Bushing

The single sided bushing is assembled at the time of the order. The bushing side extension must be specified by the customer before assembly. The bushing is installed into the unit for shipping and is not interchangeable once the unit is assembled.

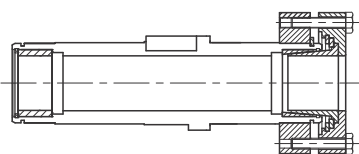

Support Side

Clamp Side

Mounting Hollow Output Reducers

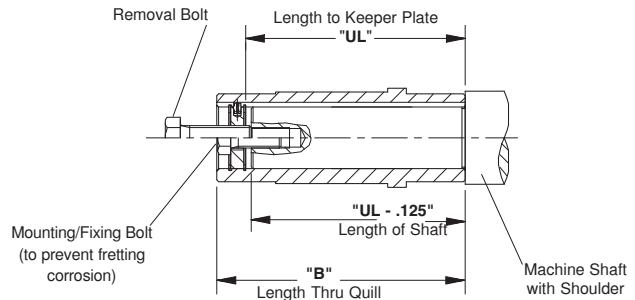

A STOBER hollow output reducer can be mounted from either side. The sizes of the hollow bores are shown in the table below and the shaft should be toleranced to an ISO k6 standard to fit this bore.

A keeper plate inside the quill is provided with each unit to prevent axial movement. This keeper plate is held in place with snap rings and can be easily removed for location on either end. A spring pin in the keeper plate mounts into the keyway of the quill and prevents rotation. The keeper plate center hole is tapped to fit the removal bolt.

Before installation, brush the inside of the quill with rust inhibiting grease. When mounting the unit onto the shaft, avoid hammering as this may damage the bearings. Do not mount the reducer dry as removal may be impossible.

The drawing above shows a mounting or fixing bolt and a removal bolt. The mounting/fixing bolt should be smaller in size than the removal bolt. See tables below.

To use the keeper plate with a mounting/fixing bolt, drill and tap the end of the shaft that will be mounted into the reducer. Insert the mounting/fixing bolt through the keeper plate and thread into the shaft end. The machine shaft length should not be longer than the "UL" dimension. A shaft length of "UL minus .125" (or 3mm) will allow the shaft shoulder to pull against the face of the quill of the reducer.

Removal of Hollow Output Reducers

To dismantle the unit from the shaft, remove the mounting bolt. Thread the removal bolt into the keeper plate to press against the shaft and loosen the shaft from the unit. Removal of the reducer will be easier if the quill is greased before installation.

Table No. 1 "UL" Dimension/Removal Bolt Size

Base Module	Standard Bore - inches			Optional Bore - mm		
	UG7	UL	Bolt	U	UL	Bolt
F102	.750	2.67	3/8-16 NC	20 _{H7}	73	M8
F202/F203	1.000	3.62	3/8-16 NC	25 _{H7}	92	M12
F302/F303	1.250	4.06	1/2-13 NC	30 _{H7}	103	M12
F402/F403	1.500	4.49	3/4-10 NC	40 _{H7}	114	M20
F602/F603	2.000	5.63	3/4-10 NC	40 _{H7}	143	M20
KL102	.625	2.38	1/4-20NC	16 _{H7}	60.5	M6
KL202	.750	3.13	3/8-16 NC	20 _{H7}	79.5	M8
KSS102	1.000	3.86	1/2-13 NC	25 _{H7}	98	M10
K102	1.000	3.86	1/2-13 NC	25 _{H7}	98	M10
K202/203	1.1875	4.78	1/2-13 NC	30 _{H7}	121.5	M10
KSS202	1.25	4.45	5/8-11 NC	30 _{H7}	113	M12
KSS302	1.375	4.92	5/8-11 NC	35 _{H7}	125	M12
K302/303	1.375	4.92	5/8-11 NC	35 _{H7}	125	M12
K402/403	1.500	6.18	3/4-10 NC	40 _{H7}	157	M16
K513/514	2.000	6.49	3/4-10 NC	50 _{H7}	164	M16
K613/614	2.000	7.05	3/4-10 NC	50 _{H7}	179	M16
K713/714	2.375	8.43	1-8 NC	60 _{H7}	214	M20
K813/814	2.750	10.35	1-8 NC	70 _{H7}	263	M20
K913/914	3.250	12.32	1-8 NC	90 _{H7}	302	M24
K1013/K1014	4.000	14.25	1 1/4-7 NC	100 _{H7}	361	M24

⁽¹⁾ U.S. Patent Number 5,496,127



ServoFit® Modular System “KSS” Motor Mounting



General Information

Servo motors are mounted to KSS gearheads by using a motor adapter with a Rotex® coupling. This adapter requires no key but uses a friction locking split collet to clamp the shaft. A split bushing is included when the motor shaft is smaller than the input bore in the gearhead. The coupling operates free of backlash and, if installed correctly, requires no maintenance.

Tolerances for the motor must be ISO j6 on the pilot diameter and ISO k6 on the motor shaft, see Table No. 1. The motor shaft does not require a key but shaft runout, pilot concentricity and perpendicularity should meet DIN standard 42955-N.

Important: Clean the motor shaft with degreaser to remove any film of oil or grease.

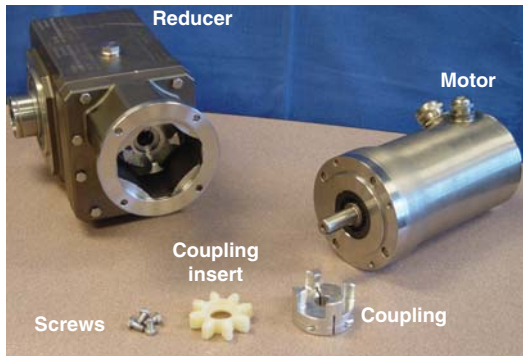

STEP 1. Install the motor coupling onto the motor shaft.

Carefully slide the coupling onto the motor shaft up to the shaft shoulder.

Measure the distance from the top of the reducer to the hooks (Photo 1) and the distance from the coupling to the flange of the adapter (Photo 2).



To prevent pre-load on the bearings, make sure there is a gap of 2mm between the two distances.

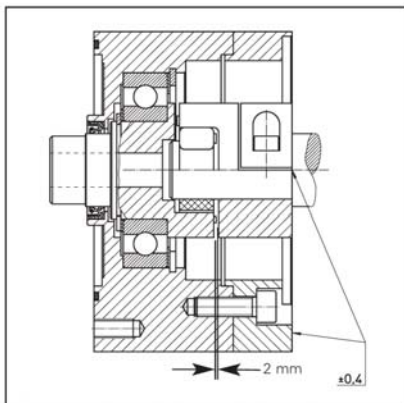

STEP 2. Tighten the screws.

Use a torque wrench to tighten the the screws to the recommended torque, shown in Table 1.



Table No. 1 Tightening Torque

Coupling Screw	Nm		inlbs		
	Nm	inlbs	Motor Bolt	Nm	inlbs
M5	3	26.6	M8	25	221.3
M5	5,9	52.2	M10	49	433.7
M6	10	88.5	M12	85	752.3

STEP 3. Install the motor.

For ease of installation, place the coupling insert onto the coupling.

With the coupling and insert installed, guide the motor shaft into the gearhead. Support the gearhead during installation as some maneuvering may be required to attain correct alignment.

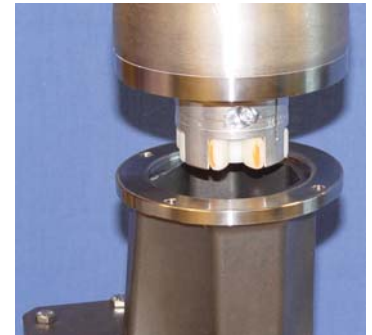

STEP 4. Install flange bolts.

Install the motor flange bolts and tighten with a torque wrench to the recommended tightening torque.



ServoCool® Ventilated Gearhead Motor Mounting Instructions



General Information

ServoCool® gearheads are air cooled planetary gearheads which allow the operating temperature to be reduced or the operating speed increased within the recommendations shown in the current catalog. Servo motors are connected to ServoFit® gearheads by using a TriAdapt® motor adapter with a clamp coupling or the FlexiAdapt® motor adapter with a bellows shaped thermal expansion feature. These patented adapters require no key but use a friction locking triple split collet to clamp the shaft. A split bushing is included when the motor shaft is smaller than the input bore in the gearhead. The coupling operates free of backlash and, if installed correctly, requires no maintenance. The fan is mounted on the motor shaft. For small diameter motor shafts, an adapter shaft is provided.

Tolerances for the motor must be ISO j6 on the pilot diameter and ISO k6 on the motor shaft, see Table No. 1. The motor shaft does not require a key but shaft runout, pilot concentricity and perpendicularity should meet DIN standard 42955-N when possible.

Important: Clean the motor shaft with degreaser to remove any film of oil or grease.



UNIT WITH FAN (without adapter shaft)

STEP 1. Install the fan and tighten setscrew.

Carefully slide the fan onto the motor shaft with the fan hub/blades facing outward.



When installed, the fan should be located as close as possible to the clamping hub in the gearhead.

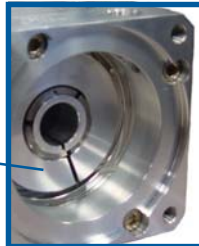

Clamping Hub



Tighten the three (3) setscrews in the fan hub to hold the fan in place.

STEP 2. Install the motor.

Place the motor (with the fan installed) into the gearhead coupling. (If there is a keyway in the motor shaft, align the slot in the clamping hub with the keyway.) Support the gearhead while sliding it onto the motor shaft.

IT IS VERY IMPORTANT THAT THE GEARHEAD IS NOT FORCED ONTO THE SHAFT AND THAT THE MOTOR IS CONCENTRIC WITH THE GEARHEAD COUPLING.



Bolt the motor flange to the gearhead motor plate. Tighten the motor bolts to the recommended tightening torque.

STEP 3. Tighten the TriAdapt coupling screw.

With a torque wrench, tighten the Allen screw in the TriAdapt coupling to the recommended torque shown in Table No. 1. A torque wrench extension is provided with each gearhead.

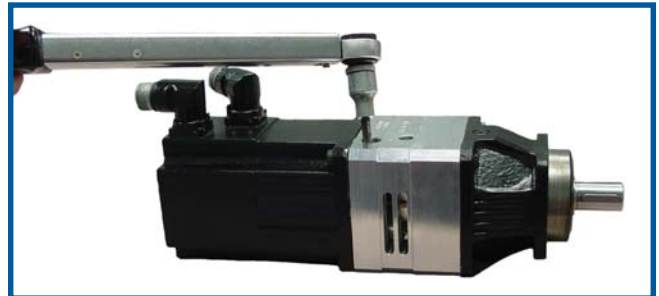

STEP 4. Insert the plastic plugs.





ServoCool® Ventilated Gearhead Motor Mounting Instructions



UNIT WITH FAN (with adapter shaft)

STEP 1. Install the fan and tighten setscrew.

Carefully slide the fan/adapter assembly into the gearhead with the fan hub/blades facing inward. The fan/adapter shaft will make a "hard stop" when inserted to the correct depth.

With a torque wrench, tighten the setscrew in the fan hub to hold the fan in place. Use the rating shown in Table No. 1.



STEP 2. Install the motor.

Place the motor into the gearhead coupling. (If there is a keyway in the motor shaft, align the slot in the clamping hub with the keyway.) Support the gearhead while sliding it onto the motor shaft.



IT IS VERY IMPORTANT THAT THE GEARHEAD IS NOT FORCED ONTO THE SHAFT AND THAT THE MOTOR IS CONCENTRIC WITH THE GEARHEAD COUPLING.

Bolt the motor flange to the gearhead motor plate. Tighten the motor bolts to the recommended tightening torque.



STEP 3. Tighten the coupling screw.

With a torque wrench, tighten the Allen screw in the coupling to the recommended torque shown in Table No. 1. A torque wrench extension is provided with each gearhead.



STEP 4. Insert the plastic plugs.



Table No. 1

Tightening Torque

Allen Wrench Size	Torque	
	Nm.	in. lbs.
2	1.5	13.3
2.5	2	17.7
3	3	26.6
4	9	35.4
5	10	88.5
6	25	221.3
8	45	398.3
10	60	531
14	210	1,858.5

ServoFit® Gearhead Selection Procedures Flow Chart

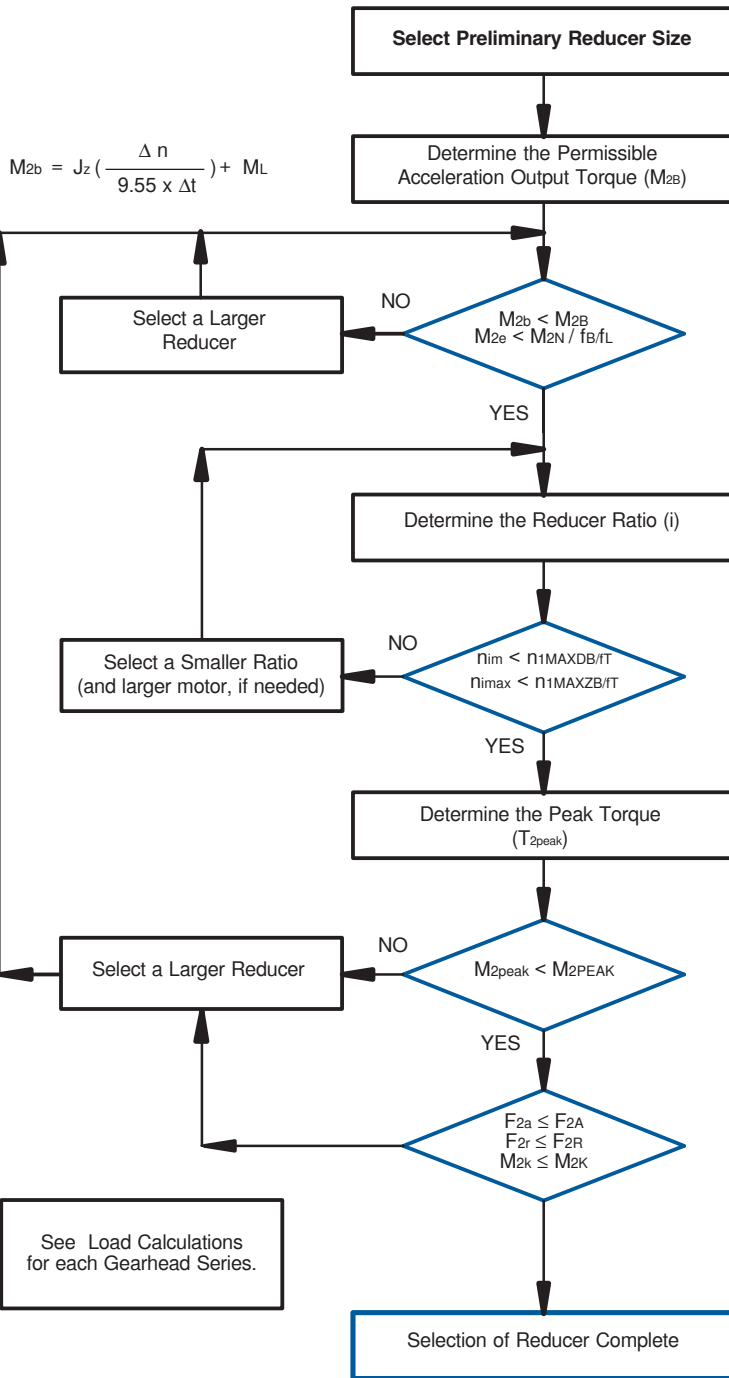
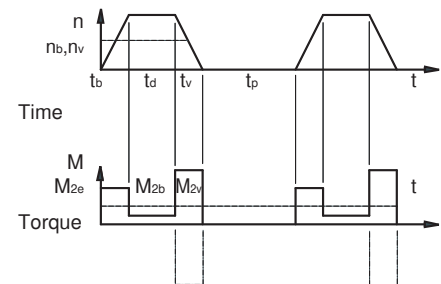

Table No. 1 ServoFit Service Factor (Apply to Nominal Rating ONLY)

Load Factor	fb	
	P(A), PH(A), PHQ(A), PHV(A), KS	P_K, PH_K, P_KX, PH_KX C, F, K
Operating Mode		
Continuous	1.0	1.0
Cyclic	1.0	1.25
Cyclic-Reversing	1.0	1.4
Running Time Factor	fl	
≤ 8 hours	1.0	
≤ 16 hours	1.15	
≤ 24 hours	1.2	
Apply to Input RPM		
Temperature Factor ¹⁾	fr	
≤ 20° C	1.0	
≤ 30° C	1.10	
≤ 40° C	1.25	

¹⁾ Without ventilation

Table No. 2 Cycle Run



$$M_{2e} = \sqrt[3]{\frac{n_{2b} \cdot t_b \cdot M_{2b}^3 + \dots + n_{2n} \cdot t_n \cdot M_{2n}^3}{n_{2b} \cdot t_b + \dots + n_{2n} \cdot t_n}}$$

Continuous Duty – a drive can be considered continuous duty if the running time ($t_r = t_b + t_d + t_v$) is 60% of the complete cycle time ($t_b + t_d + t_v + t_p$) or longer than 20 minutes.

Cyclic Duty – Drive will cycle on and off.

For cyclic operation, the recommended ratio of external (application) inertia to gearhead inertia can be determined by the following equation:

$$\frac{J_z}{j^2} = 4 \cdot J_D$$

The gearhead selected, using the following equation for inertia ratio, will result in the lowest motor torque demand and the optimum drive selection.

$$\frac{J_z}{j^2} = J_D$$



ServoFit® Gearhead Value Explanation

Table No. 3 Index of Values and Symbols

Symbol	Value			Description
	Imperial	Multiplier	Metric	
F2a	lbs.	4.45	N	Axial Force @ Output Shaft
F2A	lbs.	4.45	N	Permissible Axial Force
F2r	lbs.	4.45	N	Radial Force @ Output Shaft
F2R	lbs.	4.45	N	Permissible Radial Load
F2Rb	lbs.	4.45	N	Acceleration Permissible Radial Load
f _B	—	—	—	Load Factor
i	—	—	—	Reducer Ratio
J _D	lb-in-s ²	1.13×10 ³	kgcm ²	Motor + Reducer Inertia @ Motor RPM
J _Z	lb-in-s ²	1.13×10 ³	kgcm ²	Total Inertia @ Reducer RPM
M	in.lbs.	.113	Nm	Torque
M ₂	in.lbs.	.113	Nm	Application Torque
M _{2e}	in.lbs.	.113	Nm	Equivalent Torque (Average RMS Torque)
M _L	in.lbs.	.113	Nm	Friction Torque (Losses)
M _{2b}	in.lbs.	.113	Nm	Application Acceleration Torque
M _{2B}	in.lbs.	.113	Nm	Reducer Acceleration Torque
M _{2K}	in.lbs.	.113	Nm	Reducer Tilting Moment
M _{2KB}	in.lbs.	.113	Nm	Reducer Acceleration Tilting Moment
M _{2N}	in.lbs.	.113	Nm	Reducer Nominal Output Torque
M _{2peak}	in.lbs.	.113	Nm	Application Peak Torque
M _{2PEAK}	in.lbs.	.113	Nm	Reducer Peak Torque
M _{2V}	in.lbs.	.113	Nm	Application Deceleration Torque
n	RPM	—	min ⁻¹	Speed
n _b	RPM	—	min ⁻¹	Acceleration Speed
n _v	RPM	—	min ⁻¹	Deceleration Speed
n ₁	RPM	—	min ⁻¹	Input Speed
n ₂	RPM	—	min ⁻¹	Reducer Output Speed
t	seconds	—	seconds	Time
t _b	seconds	—	seconds	Acceleration Time
t _d	seconds	—	seconds	Duration Time
t _v	seconds	—	seconds	Deceleration Time
t _p	seconds	—	seconds	Pause Time
t _r	seconds	—	seconds	Running Time

Table No. 4 Conversions Factors

Imperial		
1 inch	x 25.4	= mm
1 in ²	x 645.16	= mm ²
1 lb	x .453	= kg
1 US gal	x 3.785	= L
1 HP	x .746	= kW
1 lb	x 4.45	= N
1 lb in	x .113	= Nm
1 lb ft	x 1.36	= Nm
1 lb ft	x .1383	= kgm
1 lb in	x .0115	= kgm
1 lb in ²	x .00029	= kgm ²
1 PSI	x .0689	= bar
1 PSI	x .00689	= N/mm ²
	°F	= 32 + 5/9 x °C
Metric		
mm	x .03937	= inch
1 mm ²	x .0015	= in ²
1 kg	x 2.205	= lb
1 L	x .264	= US gal
1 kW	x 1.341	= HP
1 N	x .225	= lb
1 Nm	x 8.85	= lb in
1 Nm	x .737	= lb ft
1 kgm	x 7.233	= lb ft
1 kgm	x 86.798	= lb ft
1 kgm ² (J)	x 3418.0	= lb in ² (WR ²)
1 bar	x 14.5	= PSI
1 N/mm ²	x 145.04	= PSI
	°C	= 5/9 (°F-32)
Formulas		
.2618 x Dia.(ins) x RPM = FPM		
.00314 x Dia.(mm) x RPM = MPM		

Table No. 5 Backlash Comparison – Arcminute vs Linear Distance

Arcminute	Degrees	Linear Distance in Inches			
		at 3" R	at 12" R	at 24" R	at 48" R
1	.017	.0009	.0035	.0070	.0140
2	.033	.0017	.0070	.0140	.0279
3	.050	.0026	.0105	.0209	.0419
4	.067	.0035	.0140	.0279	.0558
5	.083	.0044	.0175	.0349	.0698
6	.100	.0052	.0209	.0419	.0838
7	.117	.0061	.0244	.0489	.0977
8	.133	.0070	.0279	.0558	.1117
9	.150	.0079	.0314	.0628	.1257
10	.167	.0087	.0349	.0698	.1396
11	.183	.0096	.0384	.0768	.1536
12	.200	.0105	.0419	.0838	.1675
13	.217	.0113	.0454	.0908	.1815
14	.233	.0122	.0489	.0977	.1955
15	.250	.0131	.0524	.1047	.2094
16	.267	.0140	.0558	.1117	.2234
17	.283	.0148	.0593	.1187	.2373
18	.300	.0157	.0628	.1257	.2513
19	.317	.0166	.0663	.1326	.2653
20	.333	.0175	.0698	.1396	.2792

These values can be interpolated for backlash or distances not shown in the table.

$$\text{Backlash in Arcminutes} = \left(\frac{\text{Linear Backlash in Inches} \times 57.296}{\text{Radius}} \right) 60$$

Table No. 5 can be used to determine the amount of linear movement that will be realized with a given backlash value.

Example:

A "K" Series gearhead is mounted, with the output shaft vertical, under a 24" diameter turntable. The gearhead backlash is 10 arcminutes.

Reading across the table, the angular value of 10 arcminutes is .167 degrees.

Further determination indicates 10 arcminutes backlash will allow a linear movement of .0349 inches when measured at a 12 inch radius.

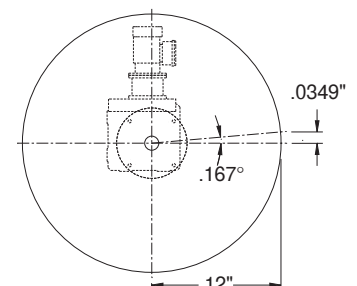

Terms and Conditions of Sale



1. **GENERAL.** All orders for products supplied by STOBER DRIVES INC. ("STOBER") shall be subject to these terms and conditions of sales. All transactions shall be governed by the laws of the Commonwealth of Kentucky. No modifications hereto will be binding unless agreed to in writing by STOBER.

2. **CUSTOMER.** The term "Customer," as used herein, means the distributor, resale dealer, original equipment manufacturer or first end-user customer that purchases the STOBER products.

3. **WARRANTY.** STOBER products shall be free from defects in material and workmanship for a maximum of 5-years (single shift operation or 30 months multiple shift operation) for ServoFit products (ServoFit Modular System, ServoFit Precision Planetary Gearheads, and ServoFit Geared Motors) and MGS Long Life products; 3-years (single shift operation or 18 months multiple shift operation) for other MGS products; 2-years (single shift operation or 12 months multiple shift operation) for ComTrac products, from the date of shipment to the Customer. For ServoFit products, the motor on ServoFit Geared Motors, as well as all normal wear items, including oil seals and bearings, shall be covered for a period of 2-years (single shift operation or 12 months multiple shift operation). In the event that a product proves to be defective, STOBER's sole obligation shall be, at its option, to repair or replace the product. The repaired or replacement product will be shipped F.O.B. STOBER'S facilities, freight prepaid by STOBER.

No employee, agent or representative of STOBER has the authority to waive, alter, vary or add to the terms hereof without the prior written approval of an officer of STOBER. It is expressly agreed that (a) this section constitutes the final expression of the parties' understanding with respect to the warranty and (b) this section is a complete and exclusive statement of the terms of the warranty.

STOBER shall have no obligation under the warranty set forth above in the event that:

(a) The Customer fails, within the warranty period to notify STOBER in writing and provide STOBER with evidence satisfactory to STOBER of the alleged defect within five (5) days after it becomes known to the customer;

(b) After inspection of a product, STOBER determines, in its sole discretion, that it is not defective in material or workmanship;

(c) Repair or replacement of a product is required through normal wear and tear;

(d) Any part in a product or any ingredient contained in a product requires replacement or repair through routine usage or normal wear and tear;

(e) A product is not maintained or used in accordance with STOBER's applicable operating and/or maintenance manuals, whether by the Customer or any third party;

(f) A product has been subject to misuse, misapplication, negligence, neglect (including, but not limited to, improper maintenance or storage), accident, catastrophe, improper installation, modification, adjustment, repair or lubrication, whether by the Customer or any third party, without the prior written consent of STOBER. Misuse shall include, but not be limited to, deterioration in a product due to chemical action and wear caused by the presence of abrasive materials;

(g) The system of connected rotating parts into which the product becomes incorporated is not compatible with the product, or it is not free from critical speed or torsional or other type of vibration within the specified operating range, no matter how induced; or

(h) The transmitted load and imposed torsional thrust and overhung loads are not within the published capacity limits for the unit sold.

Items manufactured by other parties but installed in or affixed to STOBER'S products are not warranted by STOBER and bear only those warranties, express or implied, which are given by the manufacturer of such items, if any.

THE WARRANTY SET FORTH ABOVE IS INTENDED SOLELY FOR THE BENEFIT OF THE Customer AND DOES NOT APPLY TO ANY THIRD PARTY. ALL CLAIMS MUST BE MADE BY THE Customer AND MAY NOT BE MADE BY ANY THIRD PARTY. THIS WARRANTY MAY NOT BE TRANSFERRED OR ASSIGNED, IN WHOLE OR IN PART, BY THE Customer FOR ANY REASON WHATSOEVER. ANY SUCH ATTEMPTED TRANSFER OR ASSIGNMENT SHALL BE NULL AND VOID.

THIS WARRANTY TAKES THE PLACE OF ALL OTHER WARRANTIES, EXPRESS OR IMPLIED, WHICH ARE HEREBY DISCLAIMED AND EXCLUDED BY STOBER, INCLUDING WITHOUT LIMITATION, ANY WARRANTY OF MERCHANTABILITY OR FITNESS FOR A PARTICULAR PURPOSE OF USE AND ALL OBLIGATIONS OR LIABILITIES ON THE PART OF STOBER FOR DAMAGES ARISING OUT OF OR IN CONNECTION WITH THE USE, REPAIR OR PERFORMANCE OF THE PRODUCTS.

4. **MODIFICATIONS.** STOBER reserves the right, without notice to the Customer, to (a) change the specifications of any product, (b) improve a product in any manner that STOBER deems necessary or appropriate and (c) discontinue the manufacture of any product.

5. **PURCHASE ORDERS.** The Customer will submit purchase orders for the products to STOBER in writing, whether by mail or telefax, which shall set forth, at a minimum: (a) an identification of the products ordered, (b) prices for such products, (c) quantities, (d) requested delivery dates and (e) shipping instructions and shipping addresses.

6. **ACCEPTANCE OF ORDERS.** All purchase orders received from the Customer are subject to acceptance by STOBER in writing.

7. **MODIFICATION OF ORDERS.** No accepted purchase order shall be modified or canceled except upon the written agreement of STOBER and the Customer. Mutually agreed cancellations shall be subject to reasonable charges based upon expenses already incurred by STOBER and commitments made by STOBER. Mutually agreed change orders shall be subject to all provisions of these Terms and Conditions of Sale.

8. **PRICE INCREASES.** STOBER may increase its prices for the products by providing the original purchaser of the products with at least thirty (30) days' prior written notice. Increased prices for products shall not apply to purchase orders accepted prior to the effective date of the price increase unless such orders provide for delivery more than thirty (30) days after the date of acceptance of the order.

9. **PRICING AND DELIVERY TERMS.** In accordance with KRS 355.2-319(1)(b), all products are delivered F.O.B. STOBER'S warehouse facility in Maysville, Kentucky, or such other facility as STOBER may designate. Orders are then shipped per Customer's shipping instructions as set forth in Customer's purchase order. **CATALOG PRICING DOES NOT INCLUDE SHIPPING, HANDLING AND TAXES.** Once delivered to a common carrier of the Customer's choosing [or of STOBER'S choosing if Customer has failed to specify a common carrier on or before five (5) days prior to the requested delivery date] STOBER shall have no further responsibility for the products and all risk of damage, loss or delay shall pass to the Customer. A handling fee is added to freight costs by STOBER to cover the cost of having to pay the carrier within seven (7) days when the terms with the Customer are net 30. The Customer has the option of shipping collect with our carrier or the carrier of choice.

10. **PAYMENT TERMS.** Net 30 days. All orders will be shipped either prepaid by the Customer or C.O.D., at STOBER'S option, unless the Customer has established a previously approved credit line. If STOBER approves a credit line for the Customer, all payments shall be due within thirty (30) days of the date of the invoice. If any invoice is not paid in full within such thirty (30) day period, then finance charges shall be assessed at the rate of one and one-half percent (1½%) per month (eighteen percent (18%) per

year). If such rate is deemed to be usurious at any time, it shall be reduced to the maximum rate permitted by applicable law. STOBER may stop or withhold shipment of products if the Customer does not fulfill its payment obligations. If STOBER is insecure about payment for any reason, STOBER may require full or partial payment in advance and as a condition to the continuation of its delivery of products.

11. **SECURITY INTEREST.** Unless and until the products are paid for in full, STOBER reserves a security interest in them to secure the unpaid balance of the purchase price. The Customer hereby grants to STOBER a power of attorney, coupled with an interest, to execute and file on behalf of the Customer all necessary financing statements and other documents required or appropriate to protect the security interest granted herein.

12. **ACCEPTANCE OF PRODUCTS.** The Customer will conduct any incoming inspection tests as soon as possible upon arrival of the products, but in no event later than ten (10) days after the date of receipt. Any products not rejected by written notice to STOBER within such period shall be deemed accepted by the Customer. STOBER shall not be liable for any additional costs, expenses or damages incurred by the Customer, directly or indirectly, as a result of any shortage, damage or discrepancy in a shipment.

13. **LIMITATION OF REMEDIES.**

(a) STOBER SHALL NOT BE LIABLE FOR ANY LOSS OR DAMAGE CAUSED BY DELAY IN FURNISHING THE CUSTOMER WITH PRODUCTS.

(b) IN NO EVENT SHALL STOBER'S LIABILITY INCLUDE ANY SPECIAL, INDIRECT, INCIDENTAL OR CONSEQUENTIAL LOSSES OR DAMAGES, EVEN IF STOBER HAS BEEN ADVISED OF THE POSSIBILITY OF SUCH POTENTIAL LOSS OR DAMAGE.

14. **MADE-TO-ORDER PRODUCTS.** STOBER reserves the right to revoke and amend any price quotations offered to the Customer for made-to-order products, provided that such price quotations have not been accepted by the Customer prior to the date of revocation or amendment.

15. **DIES, TOOLS AND EQUIPMENT.** Charges incurred by the Customer for dies, tools and other equipment shall not confer ownership or the right to possession therein by the Customer. All such dies, tools and equipment shall remain the property of STOBER, and STOBER shall have the exclusive right to possession thereof. STOBER shall maintain such tools and equipment in good working order.

16. **REGULATORY LAWS AND STANDARDS.** STOBER makes no representation that its products conform to state or local laws, ordinances, regulations, codes or standards except as may be otherwise agreed to in writing by STOBER.

17. **SIZES AND WEIGHTS.** STOBER'S products are made only in the sizes and to the specifications set forth in its catalogs and other literature. If any alteration is requested, such altered product will be treated as a made-to-order item. STOBER assumes no responsibility for typographical errors which may appear in its catalogs or literature, and cannot accept alteration charges caused by such errors. Since weights shown in STOBER'S catalogs are approximate, they cannot be used in determining freight allowances set forth in its catalogs and other literature. Freight allowances will be determined at the time of shipment and shall be based on actual shipping weight.

18. **SYSTEM DESIGN.** Responsibility for system design to ensure proper use and application of STOBER'S products within their published specifications and ratings rests solely with the Customer. This includes, but is not limited to, an analysis of loads created by torsional vibrations within the entire system, regardless of how induced.

STOBER DRIVES INC.

1781 Downing Drive • Maysville, KY 41056
Phone: (606) 759-5090 • FAX: (606) 759-5045
www.stober.com • E-mail: sales@stober.com



Geared to a higher standard™



STÖBER
Geared to a higher standard™

1781 Downing Drive
Maysville, KY 41056

(800) 711-3588

Fax (606) 759-5045
e-mail: sales@stober.com
www.stober.com

August 2011

STÖBER

STÖBER SELVOTTI Gearheads

2011