



NEW

Large Lead Series

Compact Caged Ball Screw

Capable of operating at high speed 5000 min⁻¹ (max DN value: 130,000)
Achieves a slim nut with a new circulation system
Low noise, long-term maintenance-free operation,
low torque fluctuation

SDA

Contributes to downsizing the equipment and lowering the center of gravity

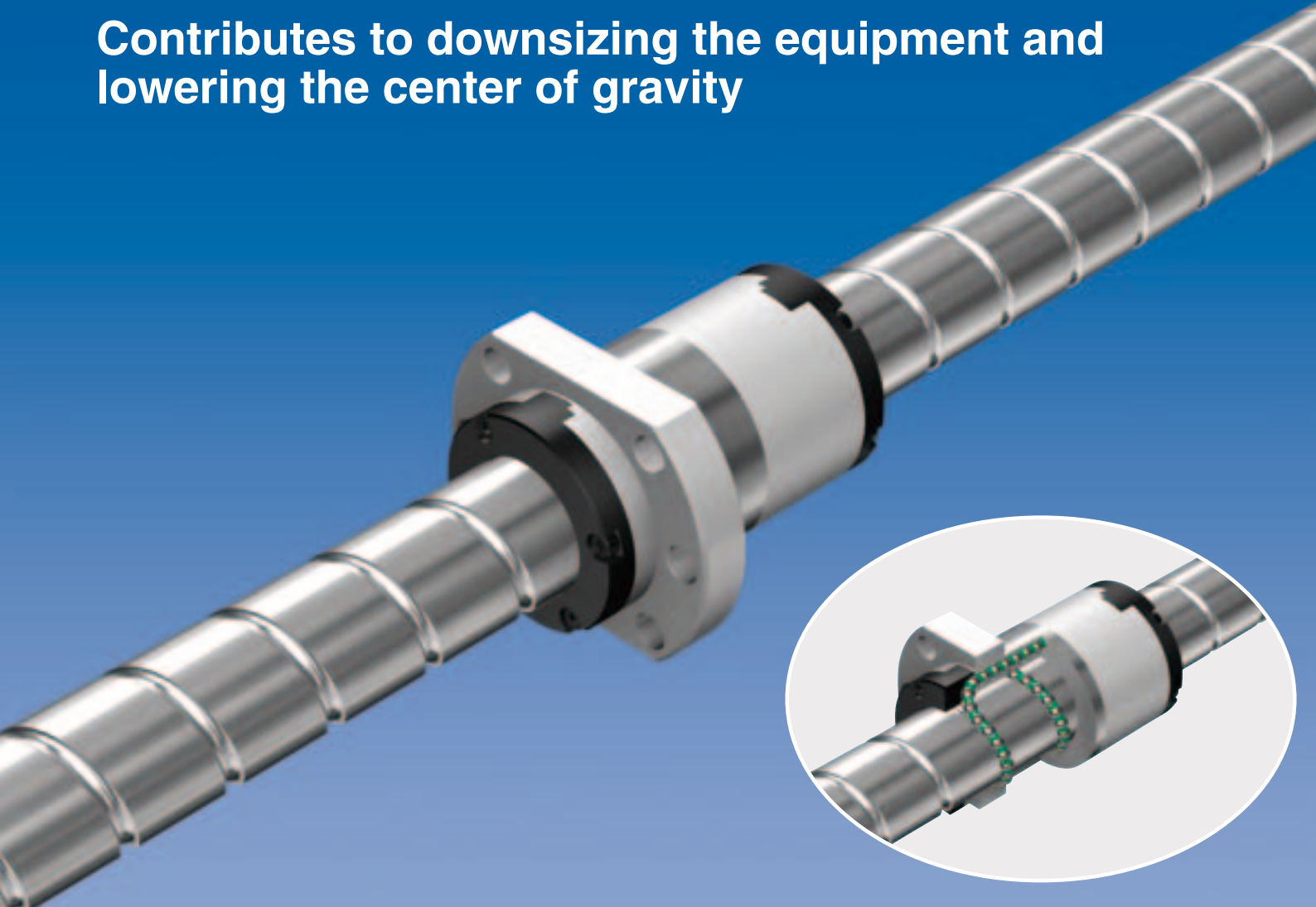

● For details, visit THK at www.thk.com ●
*Product information is updated regularly on the THK website.

Compact Caged Ball Screw

Structure

Model SDA is a compact Ball Screw with ball cage that adopts an end-cap circulation system.

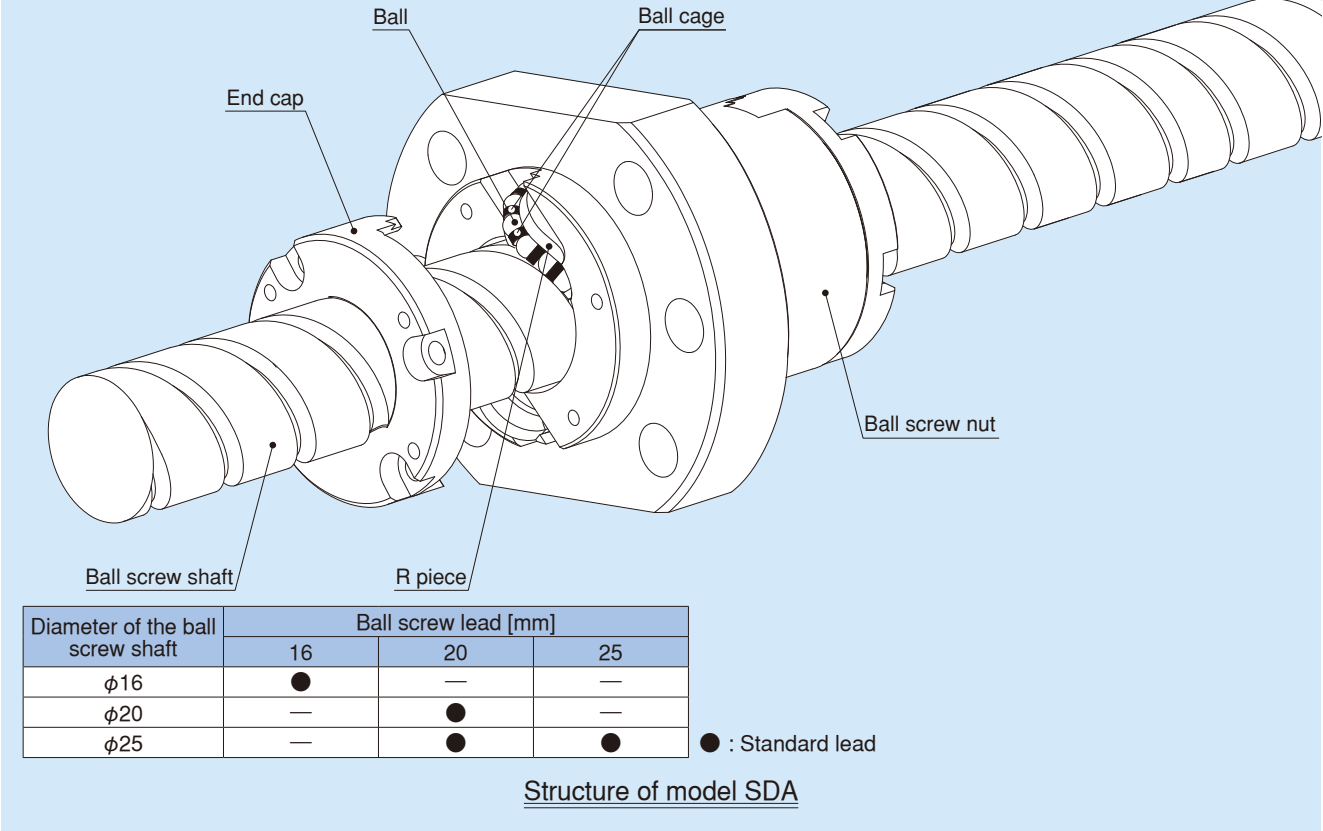

Features

Superb high-speed response

Use of a newly developed end cap and R piece achieves an ideal ball-circulation structure. This enables SDA to perform high-speed operation at 5000 min⁻¹ (maximum DN value: 130,000) (approx. twice the previous model).

Ideal structure for ball circulation in the tangential direction

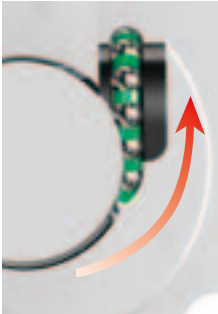

Circulate in the tangential direction

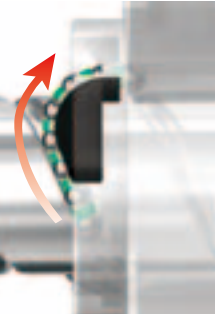

Circulate in the lead-angle direction

● Slim nut with a new circulation system

Use of a newly developed end cap and R piece achieves an ideal ball-circulation structure and significant downsizing of the product.

The nut dimensions are compliant with a DIN standard (DIN69051).*

* DIN standards refer to “Deutsche Industrie Normen” (German industrial standards) established by “Deutsches Institut für Normung e.V.” (DIN, German Institute for Standards in English), and are broadly used as standards in all industrial fields in many countries in Europe, Asia, etc.



**Downsized by 30% max
in outer diameter**

(in comparison to THK’s previous return-pipe system)

● Long-term maintenance-free operation

Use of a ball cage enables the formation of a grease pocket to increase grease retention, achieving long-term maintenance-free operation.

● Low noise, comfortable running sound

Use of a ball cage eliminates collision noise between balls and ensures comfortable running sound. In addition, an ideal circulation structure consisting of a newly developed end cap and R piece further reduces noise.

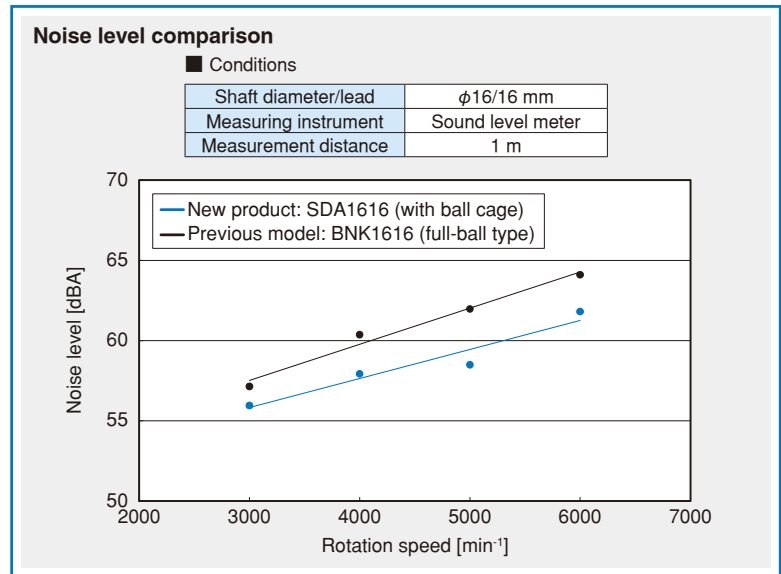

● Smooth motion

Since the use of a ball cage eliminates collision and mutual friction between balls, smooth and stable motion with low torque fluctuation is achieved.

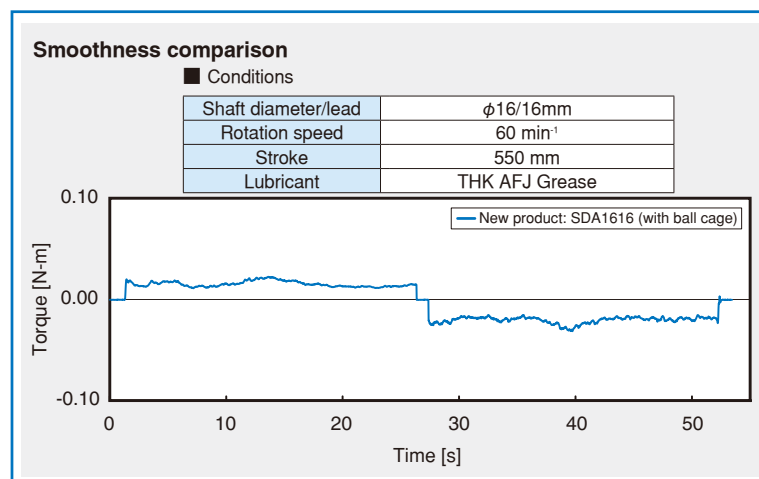
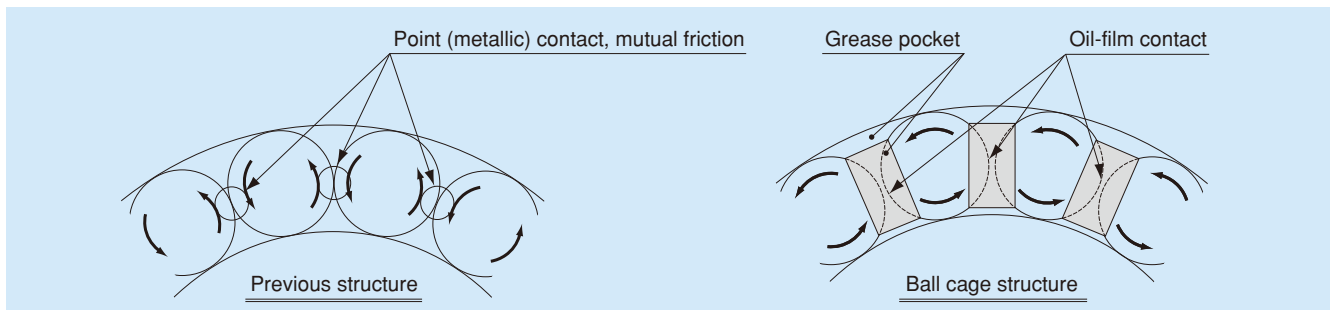

Lead accuracy and axial clearance

Lead accuracy

Compliant with ISO (International Organization for Standardization) standards and DIN standards (Deutsche Industrie Normen), in addition to the formerly observed JIS (Japanese Industrial Standards).

Correspondence table of accuracy standards

Accuracy standard	Lead accuracy						
	JIS	C0	C1	C2*	C3	C5	C7
ISO(DIN)	—	Cp1	—	Cp3	Cp5	—	—

* Represents lead accuracy under THK standards.

Axial clearance

Since model SDA adopts oversized ball preloading, the user can select an axial clearance according to the use.

Clearance symbol	Axial clearance				Unit: mm
	G0	GT	G1	G2	
Axial clearance	0 or less	0 to 0.005	0 to 0.01	0 to 0.02	0 to 0.05

Options

For model SDA, QZ Lubricators and Wiper Rings for Ball Screws are available as options. QZ Lubricators which contains a highly oil impregnated fiber net are designed for long term maintenance free operation. Contact type seal, Wiper Ring W, excels in foreign material removal.

QZ Lubricator

QZ Lubricator is a lubrication system that supplies the adequate amount of lubricant to the raceway of the ball screw shaft.

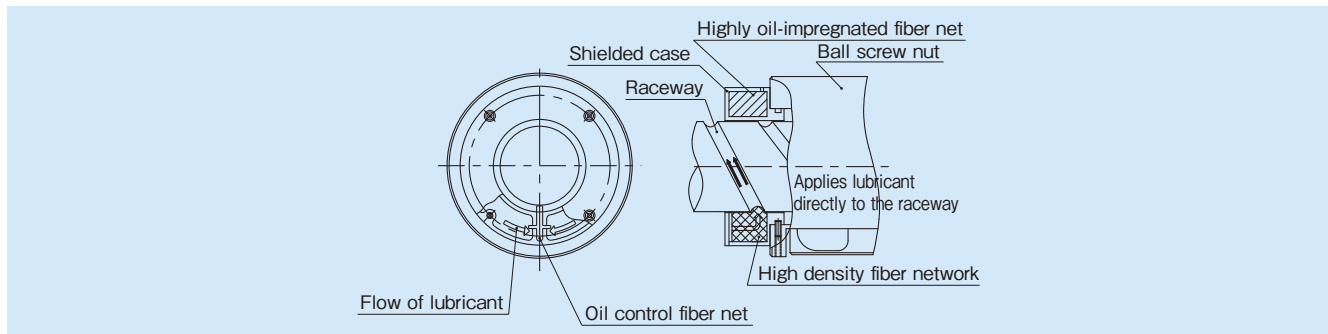

<Features>

● Significantly extends maintenance interval

With ordinary grease lubrication in Ball Screws, a slightly amount of oil is lost as the Ball Screw operates. Attaching QZ Lubricator will supplement the oil loss over a long period of time and significantly extend the maintenance interval.

● An eco-friendly lubrication system

Since QZ Lubricator supplies the adequate amount of oil to the appropriate place through a high-density fiber net, it is an eco-friendly lubrication system that does not waste oil.

Wiper ring W

In wiper ring W, a highly wear resistant special resin elastically contacts the circumference and thread groove of the ball screw shaft, and removes foreign material from eight slits, preventing it from entering the ball screw nut.

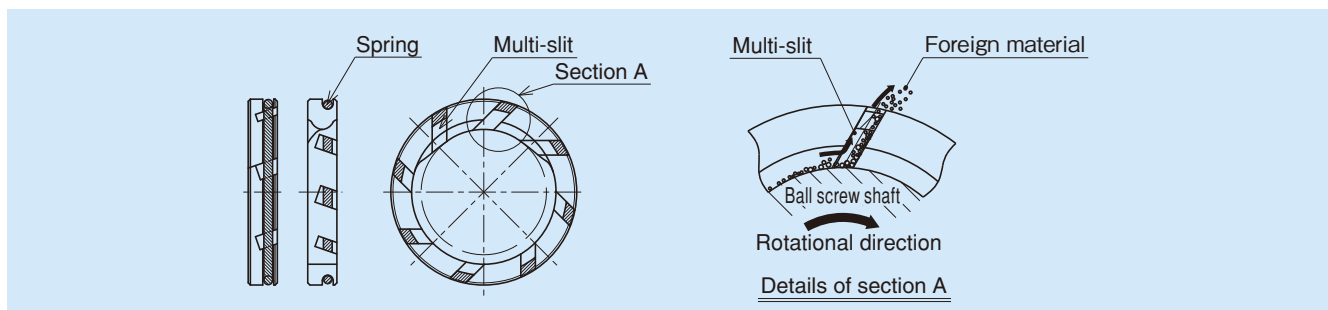

<Features>

● Prevents foreign material from entering the ball screw nut.

● Contacts the ball screw shaft at constant pressure to reduce heat generation.

● Excels in resistance to wear, impact and chemicals.

● Attaching QZ Lubricator for Ball Screws and wiper ring W would significantly extend the maintenance interval even in a harsh environment.

Static safety factor

Basic static load rating C_{0a}

Basic static load rating (C_{0a}) generally means the permissible axial load of a Ball Screw. Depending on the service conditions, it is necessary to consider the following static safety factor for the calculated load. Note that when a Ball Screw is stationary or in motion, an unexpected external force may be applied due to an inertial force generated through collision or start/stop action.

Static safety factor f_s

$$f_s \geq \frac{C_{0a}}{F_a}$$

f_s : Static safety factor (Table 1)
 C_{0a} : Basic static load rating*1 [kN]
 F_a : Axial load [kN]

Table 1 Static safety factor (f_s)

Machine using the Ball Screw	Load conditions	Lower limit of f_s
General industrial machines	Without vibrations/impact	1.0 to 3.5
	With vibrations/impact	2.0 to 5.0
Machine tools	Without vibrations/impact	1.0 to 4.0
	With vibrations/impact	2.5 to 7.0

*1 Basic static load rating (C_{0a}) refers to the static load with a uniform direction and magnitude at which the sum of the permanent deformation of the rolling element and the permanent deformation of the raceway is 0.0001 times the diameter of the rolling element at a contact point to which the maximum stress is applied. The basic static load rating of a Ball Screw is defined on the basis of the axial load (specific value of each Ball Screw model is indicated in the dimensional table of the respective model).

Rated life and service life time

Basic dynamic load rating C_a

Basic dynamic load rating (C_a) is used to calculate the service life of a Ball Screw operating under a load. Basic dynamic load rating (C_a) refers to the load with constant direction and magnitude at which the rated life L is 10^6 [rev] when a group of identical Ball Screw units independently operate (basic dynamic load rating (C_a) is indicated in the dimensional table of the respective model).

Rated life L (total number of revolutions)

The service life of a Ball Screw is obtained from the following equation based on the basic dynamic load rating and the applied axial load.

$$L = \left(\frac{C_a}{f_w \cdot F_a} \right)^3 \times 10^6$$

L : Rated life (total number of revolutions) [rev]
 C_a : Basic dynamic load rating*2 [kN]
 F_a : Applied axial load [kN]
 f_w : Load factor (Table 2)

Table 2 Load factor (f_w)

Vibrations/impact	Velocity (V)	f_w
Very Low	Very slow $V \leq 0.25$ m/s	1.0 to 1.2
Low	Slow 0.25 m/s < $V \leq 1.0$ m/s	1.2 to 1.5
Medium	Medium 1.0 m/s < $V \leq 2.0$ m/s	1.5 to 2.0
High	High 2.0 m/s < V	2.0 to 3.5

*2 The rated life is calculated through load calculation assuming that favorable lubrication is secured and the product is assembled under ideal mounting conditions. The accuracy and deformation of the mounting member may affect the service life.

Service life time L_h

When the rated life (L) has been obtained, the service life time (L_h) is obtained from the following equation if the stroke length and the number of reciprocation are constant.

$$L_h = \frac{L \times Ph}{2 \times \ell_s \times n_1 \times 60}$$

L_h : Service life time [h]
 ℓ_s : Stroke length [mm]
 n_1 : Number of reciprocations per minute [mm^{-1}]
 Ph : Lead [mm]

Dimensional table of model SDA

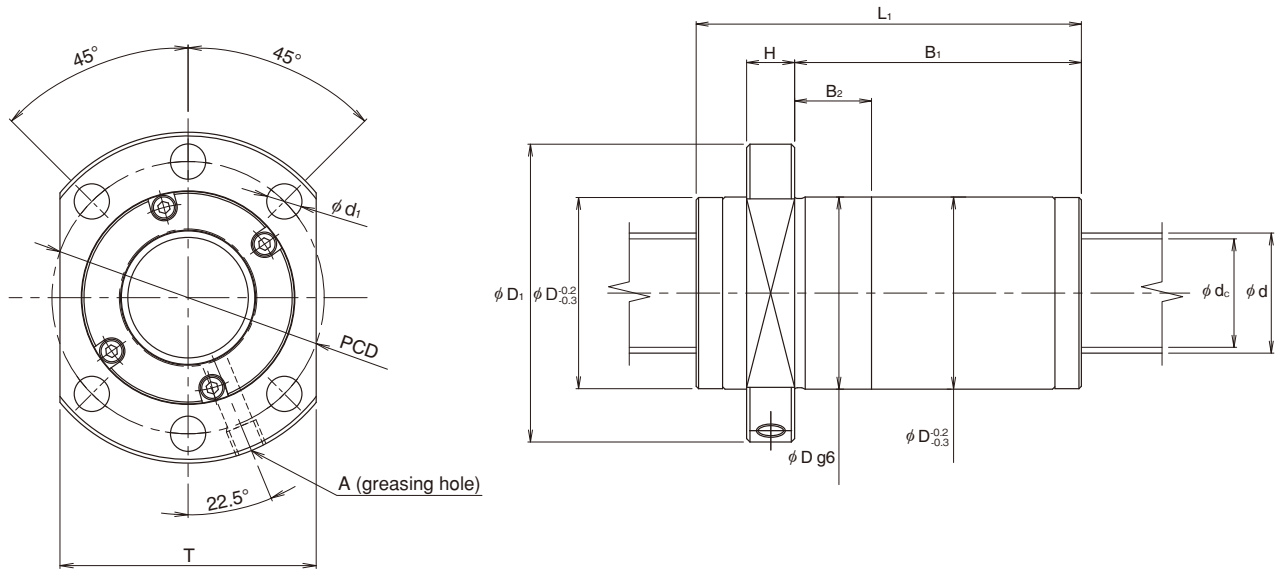

Unit: mm

Model No.	Screw shaft outer diameter d	Lead Ph	Ball center-to-center diameter dp	Screw shaft root diameter dc	No. of loaded circuits Row x turns	Basic load rating		Rigidity K [N/μm] Note 2)
						Ca [kN]	C0a [kN]	
★SDA1616-2.8	16	16	16.5	14.1	1 x 2.8	5.5	8.4	152
SDA2020-2.8	20	20	20.75	17.1		10.9	17.6	207
SDA2520-2.8	25	20	25.75	22.1		12.1	21.6	245
SDA2525-2.8	25	25	25.75	22.1		12.0	22.0	246

Outer diameter D	Flange diameter D1	Overall length L1	Nut dimensions						Greasing hole A	Max permissible rotation speed [min ⁻¹] Note 1)
			H	B1	B2	PCD	d1	T		
28	48	51.9	10	33.4	10	38	5.5	40	M6	5000
36	58	65.8		45.3	12	47	6.6	44		
40	62	66.4		45.9	16	51	6.6	48		
40	62	80.2		59.7	16	51	6.6	48		

★ : The outer diameter dimension is compliant with DIN standard 69051 (lead 5 or less).

Note 1: The maximum permissible rotation speed is calculated from the DN value. Calculate the critical speed, and then select the lower value.

Note 2: Each rigidity value (K) in the table indicates the spring constant obtained from the load and the elastic deformation when an axial load at 30% of the basic dynamic load rating (Ca) is applied.

This value does not include the rigidity of parts related to the ball screw nut mounting section. Normally, apply 80% of the rigidity value (K) in the table.

If the axial load (Fa) is not 0.3 Ca, the rigidity value (Kn) is obtained from the following equation.

$$K_N = K \left(\frac{F_a}{0.3C_a} \right)^3 \quad K: \text{Rigidity value in the dimensional table}$$

●Precautions

If desiring to shape both ends of the screw shaft to have a larger diameter than the outer diameter of the screw shaft, contact THK.

Example of model number coding

SDA2520-2.8 QZ RR GO +830L C3

1

2

3

4

5

6

1 Model number **2** With QZ Lubricator (no symbol for without QZ Lubricator) **3** Seal symbol (RR: labyrinth seal on both ends; WW: wiper ring on both ends) **4** Axial clearance (see P.3) **5** Overall length of ball screw shaft (in mm) **6** Accuracy standard (see P.3)

Dimensions of the ball screw nut attached with a labyrinth seal (RR), wiper ring (WW) and QZ Lubricator (QZ)

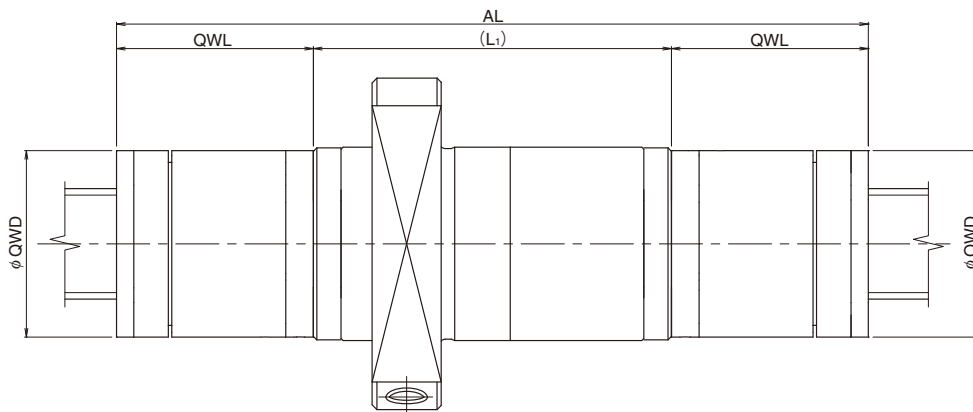
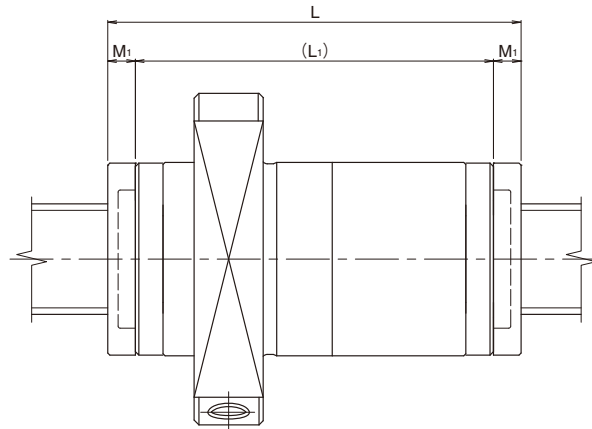

Unit: mm

Model No.	Length of projection with RR/WW attached	Dimension with RR/WW attached	Length of projection with QZ attached	Outer diameter of projection with QZ attached	Dimension with QZWW attached
	M ₁	L	QWL	QWD	AL
SDA1616-2.8	4.0	59.9	28.5	27	108.9
SDA2020-2.8	5.5	76.8	33	35	131.8
SDA2520-2.8	5.5	77.4	33	39	132.4
SDA2525-2.8	5.5	91.2	33	39	146.2

THK Compact CagedBall Screw Model SDA

Precautions on use

● Handling

- Do not disassemble the parts. Doing so may allow dust to enter the product and/or cause functional loss.
- Tilting the ball screw shaft and the ball screw nut may cause them to fall by its own weights.
- Do not drop or hit the Ball Screw. Doing so may cause personal injury and/or damage the product. Applying an impact to the product may cause functional loss even if the product looks intact.
- Do not remove the ball screw nut from the ball screw shaft. Doing so may cause balls or a ball cage to fall and make the product inoperable.
- Take care not to allow foreign material such as dust and cutting chips to enter the product. Failure to do so may damage the ball circulation part or cause functional loss.
- Some types of coolants may affect the functionality of the product. If using the product in an environment where a coolant could enter the ball screw nut, contact THK.
- Do not use the product at temperature exceeding 80°C. If the product is attached with QZ Lubricator, be sure to use it at temperature 50°C or below.
- If foreign material such as dust and cutting chips adheres to the product, replenish the lubricant after cleaning the product. For the type of the cleaning fluid, contact THK.
- If using the product for vertical application, take a measure to prevent it from falling such as adding a safety mechanism. Failure to do so may cause the ball screw nut to fall by its own weight.
- Do not use the product at speed exceeding the permissible rotation speed. Doing so may damage the product or cause an accident. Make sure that the service rotation speed is within the specification range designated by THK.
- Do not forcefully drive any component into the ball screw shaft or the ball screw nut. Doing so may cause an indentation on the raceway. Take care when mounting components.
- If misalignment or skewing occurs in the ball screw shaft support and the ball screw nut, it may substantially shorten the service life. Pay much attention to the components to be mounted and to the mounting accuracy.
- If using the product in a location constantly exposed to vibrations or in a special environment such as a clean room, vacuum, low temperature and high temperature, contact THK.
- Do not let the ball screw nut overshoot. Doing so may cause balls to fall or damage the ball circulation part.

● Lubrication

- Thoroughly wipe off anti-corrosion oil and feed lubricant before using the product.
- For use with high-speed rotation application, we have selected THK Grease AFJ for SDA Ball Screw. THK Grease AFJ provides superior performance in low-heat-generating characteristics.
- Do not mix lubricants with different physical properties.
- In locations constantly exposed to vibrations or in special environments such as a clean room, vacuum, low temperature and high temperature, normal lubricants may not be used. Contact THK for details.
- If planning to use a special lubricant, contact THK before using it.
- Lubrication interval varies according to the service conditions. Contact THK for details.
- In types attached with QZ Lubricator, the required minimum amount of lubricant is supplied to the raceway. Depending on the service conditions such as vertical application, the lubricant may drop from the ball screw shaft due to the nature of the lubricant.

● Storage

- When storing the Ball Screw, enclose it in a package designated by THK and store it in a horizontal orientation while avoiding low temperature, high temperature and high humidity.

● “LM GUIDE,” and “” are registered trademarks of THK CO., LTD.

- The photo may differ slightly in appearance from the actual product.
 - The appearance and specifications of the product are subject to change without notice. Contact THK before placing an order.
 - Although great care has been taken in the production of this catalog, THK will not take any responsibility for damage resulting from typographical errors or omissions.
 - For the export of our products or technologies and for the sale for exports, THK in principle complies with the foreign exchange law and the Foreign Exchange and Foreign Trade Control Law as well as other relevant laws.
- For export of THK products as single items, contact THK in advance.

All rights reserved

THK CO., LTD.

HEAD OFFICE 3-11-6, NISHI-GOTANDA, SHINAGAWA-KU, TOKYO 141-8503 JAPAN
INTERNATIONAL SALES DEPARTMENT PHONE:+81-3-5434-0351 FAX:+81-3-5434-0353

Global site : <http://www.thk.com/>

NORTH AMERICA

THK America, Inc.

● HEADQUARTERS

Phone:+1-847-310-1111 Fax:+1-847-310-1271

● CHICAGO OFFICE

Phone:+1-847-310-1111 Fax:+1-847-310-1182

● NORTH EAST OFFICE

Phone:+1-845-369-4035 Fax:+1-845-369-4909

● ATLANTA OFFICE

Phone:+1-770-840-7990 Fax:+1-770-840-7897

● LOS ANGELES OFFICE

Phone:+1-949-955-3145 Fax:+1-949-955-3149

● SAN FRANCISCO OFFICE

Phone:+1-925-455-8948 Fax:+1-925-455-8965

● DETROIT OFFICE

Phone:+1-248-858-9330 Fax:+1-248-858-9455

● TORONTO OFFICE

Phone:+1-905-820-7800 Fax:+1-905-820-7811

SOUTH AMERICA

THK Brasil LTDA

Phone:+55-11-3767-0100 Fax:+55-11-3767-0101

EUROPE

THK GmbH

● EUROPEAN HEADQUARTERS

Phone:+49-2102-7425-555 Fax:+49-2102-7425-556

● DÜSSELDORF OFFICE

Phone:+49-2102-7425-0 Fax:+49-2102-7425-299

● FRANKFURT OFFICE

Phone:+49-2102-7425-650 Fax:+49-2102-7425-699

● STUTTGART OFFICE

Phone:+49-7150-9199-0 Fax:+49-7150-9199-888

● MÜNCHEN OFFICE

Phone:+49-8937-0616-0 Fax:+49-8937-0616-26

● U.K. OFFICE

Phone:+44-1908-30-3050 Fax:+44-1908-30-3070

● ITALY MILANO OFFICE

Phone:+39-039-284-2079 Fax:+39-039-284-2527

● ITALY BOLOGNA OFFICE

Phone:+39-051-641-2211 Fax:+39-051-641-2230

● SWEDEN OFFICE

Phone:+46-8-445-7630 Fax:+46-8-445-7639

● AUSTRIA OFFICE

Phone:+43-7229-51400 Fax:+43-7229-51400-79

● SPAIN OFFICE

Phone:+34-93-652-5740 Fax:+34-93-652-5746

● TURKEY OFFICE

Phone:+90-216-362-4050 Fax:+90-216-569-7150

● PRAGUE OFFICE

Phone:+420-2-41025-100 Fax:+420-2-41025-199

● MOSCOW OFFICE

Phone:+7-495-649-80-47 Fax:+7-495-649-80-44

THK Europe B.V.

● EINDHOVEN OFFICE

Phone:+31-040-290-9500 Fax:+31-040-290-9599

THK France S.A.S.

Phone:+33-4-3749-1400 Fax:+33-4-3749-1401

CHINA

THK (CHINA) CO.,LTD.

● HEADQUARTERS

Phone:+86-411-8733-7111 Fax:+86-411-8733-7000

● SHANGHAI OFFICE

Phone:+86-21-6219-3000 Fax:+86-21-6219-9890

● BEIJING OFFICE

Phone:+86-10-8441-7277 Fax:+86-10-6590-3557

● CHENGDU OFFICE

Phone:+86-28-8526-8025 Fax:+86-28-8525-6357

● GUANGZHOU OFFICE

Phone:+86-20-8523-8418 Fax:+86-20-3801-0456

THK (SHANGHAI) CO.,LTD.

Phone:+86-21-6275-5280 Fax:+86-21-6219-9890

TAIWAN

THK TAIWAN CO.,LTD.

● TAIPEI HEAD OFFICE

Phone:+886-2-2888-3818 Fax:+886-2-2888-3819

● TAICHUNG OFFICE

Phone:+886-4-2359-1505 Fax:+886-4-2359-1506

● TAINAN OFFICE

Phone:+886-6-289-7668 Fax:+886-6-289-7669

KOREA

SEOUL REPRESENTATIVE OFFICE

Phone:+82-2-3468-4351 Fax:+82-2-3468-4353

SINGAPORE

THK LM SYSTEM Pte. Ltd.

Phone:+65-6884-5500 Fax:+65-6884-5550

INDIA

BANGALORE REPRESENTATIVE OFFICE

Phone:+91-80-2330-1524 Fax:+91-80-2314-8226