



Linear Actuators for On/Off-Highway Vehicles

Thomson Actuators Set the Standard in On-Off Highway Vehicles

We are the original actuator manufacturer. For over 40 years, our engineers have worked to design actuators to provide the unique features that on/off-highway applications require.

Changing technologies. On/off-highway vehicle manufacturers are taking a long, hard look at how they use motion control systems. Once dominated by pneumatic and hydraulic systems, equipment is now increasingly equipped with electric actuators for automation of a large number of tasks. Electric linear actuators are easier to control, integrate with modern computer-based control systems and are smaller, lighter and cleaner than hydraulic systems — all attributes that boost a company's bottom line. In fact, electric linear actuators eliminate:

- The need for hydraulic pumps, valves and hoses
- The cost and bulk associated with hydraulic systems
- Environmentally hazardous oil and risk of leakage
- The high energy consumption of hydraulic systems
- Costly hydraulic reliability issues (contamination)
- The cost and hassle associated with fluid maintenance

Rugged and reliable. Danaher Motion electro-mechanical linear actuators are rugged and reliable, withstanding harsh environments to:

- Make manual jobs easier to reduce operator fatigue
- Automate tasks to improve efficiency and reduce costs
- Provide remote control to increase production
- Remove operators from dangerous places to improve safety

The largest linear actuator range in the market. In addition to our extensive application and engineering expertise, Danaher Motion also has the largest range of standard and custom electrical linear actuators in the market today. For this reason we are able to provide positioning solutions for a vast array of unique on/off-highway applications for dynamic loads up to 9000 N (2000 lbf). Our success is driven by:

- Understanding the critical needs of the on/off-highway industry
- Decades of application and engineering expertise
- Robust and reliable products that withstand the harshest environments
- An extensive standard and custom product range
- Custom designs for unique on/off-highway applications

Customization. Danaher Motion is the industry leader in custom actuator design. Our design flexibility and unique customization expertise give us an advantage to quickly provide our customers with cost-effective designs that meet their exact requirements.



ELECTRAK 050

- Small, quiet and lightweight
- Very short retracted length
- Low cost
- Corrosion-free plastic housing
- End-of-stroke-limit switches



ELECTRAK 1

- The elements can put stress on a solar panel. Thomson actuators and screw jacks are built to handle these conditions with little or no service or maintenance.



ELECTRAK 10

- The original on/off-highway actuator
- Robust, strong and reliable
- Withstands very harsh environments
- Stainless steel extension tube
- Acme or ball screw models
- A variety of DC voltage models

Why Go Electric?

Replacing hydraulic and pneumatic cylinders with electrical linear actuators means a simpler and smaller installation, easier control, lower energy costs, higher accuracy, less maintenance, less noise and a cleaner, healthier environment.

Simpler, smaller installation.

- Installs with just two pins, making installation quick
- Smaller footprint created over traditional methods

Easier control.

- Operate with very little force, reducing operator effort
- By using a joystick, the operator can execute multiple motions simultaneously
- Provides remote control – increases production.

Lower energy costs.

- Electric actuation components cost less than comparable hydraulic and pneumatic systems
- One electric linear actuator is faster and easier to install than the multiple hydraulic and pneumatic components required to achieve the same function
- There is no need to upsize the current system to account for any parasitic power draw. Actuators run off a battery
- There is no need for a pump running continuously, and no amp draw to hold the load in position

Higher Accuracy.

- Holds power position when off so you don't have to keep a pump running
- Will not drift when power is off

Less maintenance.

- No need for hydraulic pumps, valves and hoses means fewer parts to malfunction or wear out
- Self-contained unit eliminates access requirements so unit can be placed virtually anywhere in the application
- No need to resize or change out hydraulic components or break into the system to add components
- Programmable and end-of-stroke limit switches extend the life of the actuator, eliminating the need for costly maintenance and replacement
- Eliminate the cost and hassle associated with fluid maintenance

Less noise.

- No pumps, air pressure or fluids needed means smooth, quiet operation

Cleaner, healthier environment.

- No fluids, chemicals or solvents necessary for operation means there is nothing to leak out or contaminate the environment
- A compact design means less materials used in production
- Regional manufacturing and distribution plants mean the product doesn't have to travel as far, reducing the carbon footprint



ELECTRAK PPA-DC

- Strong and versatile heavy duty actuator
- High duty cycle
- Long stroke lengths
- A variety of DC voltage models
- Large range of options

ELECTRAK PRO

- The next generation in actuator design
- Designed for the harshest applications
- Electronic load monitoring (ELM)
- Small size with minimal retracted length
- Acme or ball screw models
- IP66 protection as standard
- Manual override as standard
- Wide range of options

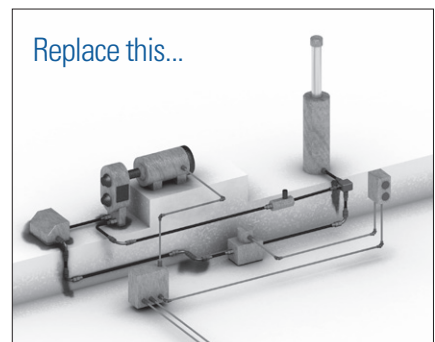

THROTTLE CONTROL

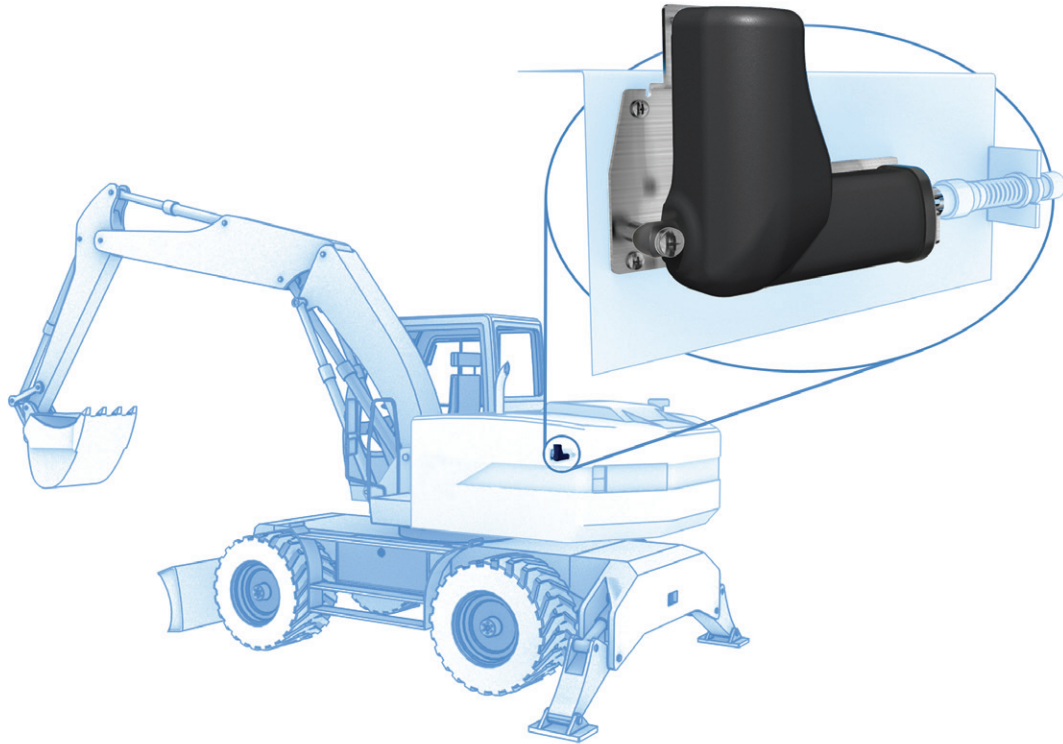

Throttle actuators allow automatic control of engine speed for reduced noise and emissions, and improved fuel economy.

Reduces design cost.

- Flexible potentiometer models allow easy interface with multiple controls
- Variety of speed options to match application requirements
- Optional mounting brackets for reduced design time
- Multiple feedback options
- Compatible with multiple engine platforms as an add-on

Reduces installation cost.

- Optional mounting brackets for easy installation
- Variety of mounting accessories
- No need to accommodate large bend radius of wire-wound throttle cables
- Allows for placement of actuator to accommodate easy installation – no direct access needed for maintenance

Reduces operating cost.

- Maintenance-free – lubricated for life
- Allows automatic return to low speed for economy and emission reduction
- Allows for automatic rapid resumption of operating speed based on demand
- Designed to withstand underhood temperatures, vibrations and moisture (IP66) and high cycle life for maintenance-free operation

Reduces working capital.

- Reduce inventory cost of engines with and without factory controls to one design

Increases safety.

- Easy interface with seat interlock, other sensors for automatic shut-off or speed reduction
- Noise management through engine rpm control
- Reduced operator fatigue with lower noise levels
- Speed controls can be placed in ergonomic positions rather than positions required by wire-wound throttle cables

Increases productivity.

- More operator up-time with fewer refueling stops – lower fuel consumption
- Automatic and immediate return to working speeds upon demand
- Automatic speed adjustments reduces the workload on the operator

QUICK ATTACH

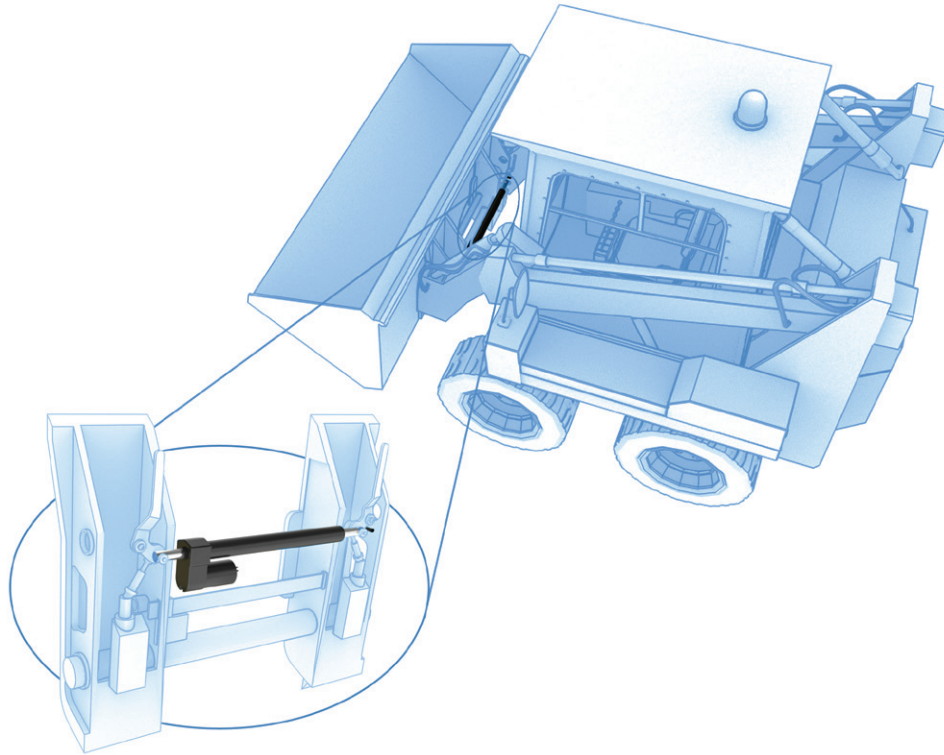

Quick-attach actuators allow the operator to change implements on the loader or skid steer without leaving the seat for improved productivity and safety.

Reduces design cost.

- Easy interface with multiple electronic controls
- Can be operated by a simple switch
- No need to accommodate large bend radius of hoses
- No need to design system of hoses, valves, controls, filters, switches

Reduces installation cost.

- Easy interface with multiple electronic controls
- Easy to retrofit into existing applications
- No need to accommodate large bend radius of hoses
- Fewer parts to install – two wires and a switch instead of valve, valve operator, hoses, filter
- Reduce installation labor and materials by eliminating hoses, valves and cylinders

Reduces operating cost.

- Maintenance-free – lubricated for life
- Replace costly, complicated hydraulic systems and long runs of hydraulic hoses
- No hoses to fatigue and rupture, no filters to change
- No chance to introduce debris into the main hydraulic operating system
- Holds position with power off – no parasitic drain on the hydraulic system
- Connection with simple wiring is easier to protect from damage than hydraulic hoses

Reduces working capital.

- Fewer parts to inventory
- Can easily be added to existing vehicle at the factory or dealer

Increases safety.

- Allows the operator to change implements without leaving his seat
- Eliminates a pair of high-pressure hoses from the operator cab
- No extra operator required to change implements
- Provide the potential for position interlock to ensure safe operation

Increases productivity.

- Faster change of implements
- Single operator can change implements without leaving the seat

HOOD LIFT

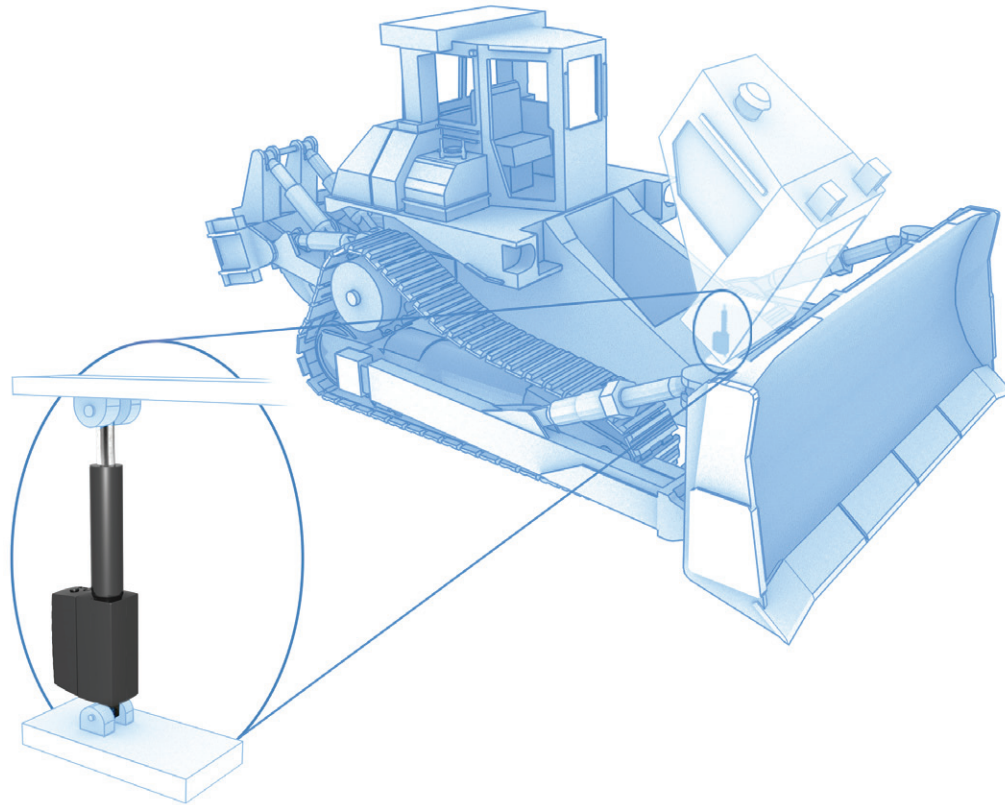

Hood lift actuators provide easy access to engines for maintenance and repair.

Reduces design cost.

- Easy interface with multiple electronic controls and interlocks
- Needs only a switch to operate
- Built-in clutch or limit switches for end-of-stroke protection
- Fewer components than hydraulic systems
- Compatible with multiple chassis platforms as an add-on
- Wide temperature range for reliable operation in all conditions

Reduces installation cost.

- Easy interface with multiple electronic controls
- Variety of mounting accessories
- Built-in clutch or limit switches for end-of-stroke protection
- Fewer components than hydraulic systems

Reduces operating cost.

- Maintenance free – lubricated for life
- High resistance to underhood temperatures, shock and vibration
- Reliable operation, won't weaken with age or low temperatures
- Provides controllable clamping force, preventing overstressing hood materials

Increases safety.

- Easy interface with interlock to prevent inadvertent operation
- Holds position with power off – no drifting or backdriving in the wind
- Reduced exposure of operator to awkward lifting positions with heavy loads
- Manual override allows operation with dead, or no battery
- Will not leak hydraulic fluid, reducing the environmental hazards and expense of clean-up

Increases productivity.

- Allows one person to lift the hood or access panels
- Includes a manual override function, allowing engine access even with vehicle battery failure or removal

SPOOL VALVE CONTROL

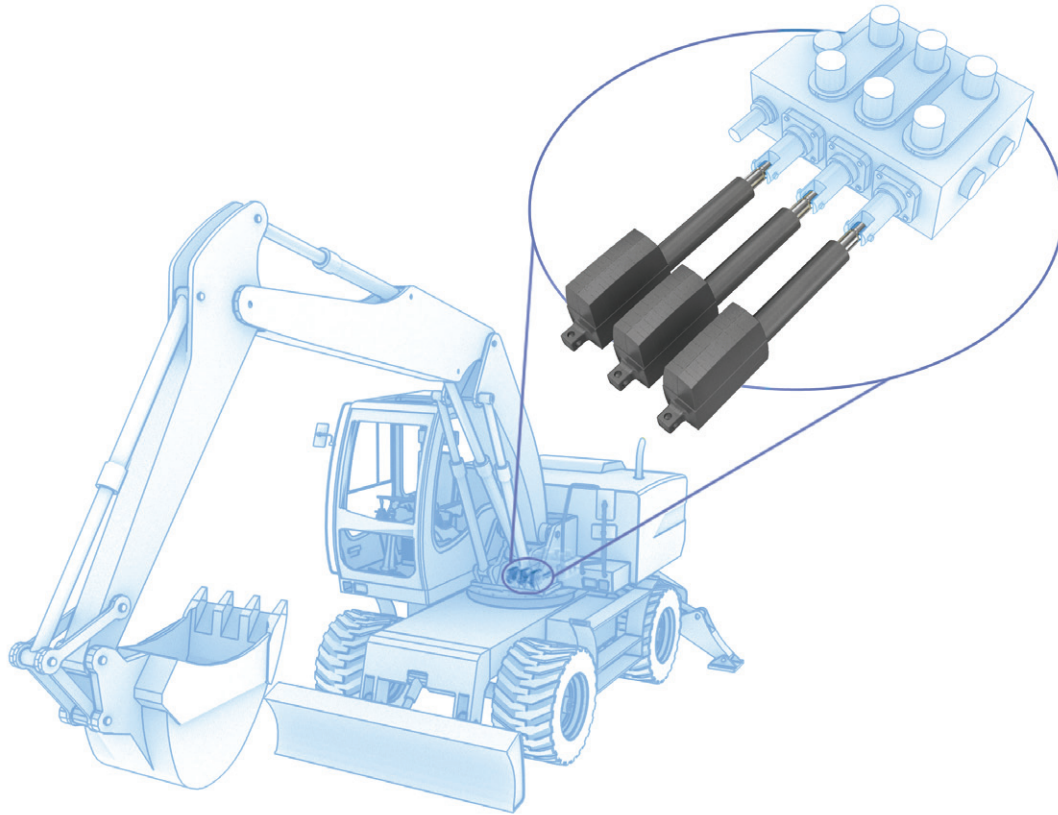

Actuators replace mechanical linkage for spool valve control of boom and tilt cylinders for front end loaders, enabling the use of joystick control.

Reduces design cost.

- Easy interface with multiple electronic controls
- Multiple speed options
- Multiple feedback options
- Wires and switch can be placed anywhere, not limited by hose bend radius or located near operator

Reduces installation cost.

- Easy interface with multiple electronic controls
- Variety of mounting accessories
- No need to accommodate large bend radius of hydraulic hoses
- Actuators allow for more flexible positioning of spool valves in the machine design for reduced installation cost, improved safety and ease of access for maintenance

Reduces operating cost.

- Maintenance free – lubricated for life
- High resistance to underhood temperatures, shock and vibration
- Allows valve to be controlled electronically for less operator fatigue

Increases safety.

- Easy interface with seat interlock and other sensors for automatic shut-off or speed reduction
- Allows valve and hoses to be removed from inside the cab, eliminating a source of heat and high-pressure hydraulics
- Reduced operator fatigue with lower noise levels when valves and hoses are out of the cab
- Programmable motions can reduce the chance of repetitive-motion injuries
- Removing multiple levers from the cab can increase operator comfort and visibility
- Interlocks can prevent dangerous combinations of moves or speeds

Increases productivity.

- Less operator fatigue using electronics instead of mechanical linkages
- Multiple operations can be combined on joystick controls allowing more simultaneous or coordinated moves
- Lower operator training time by interlocking conflicting or dangerous moves
- Joystick/actuator systems allow for user selected controls layouts – H or ISO patterns, right- or left-hand reversible
- Increases the speed of shaking the bucket for removal of debris

USA, CANADA and MEXICO

Thomson
203A West Rock Road
Radford, VA 24141, USA
Phone: 1-540-633-3549
Fax: 1-540-633-0294
E-mail: thomson@thomsonlinear.com
Literature: literature.thomsonlinear.com

EUROPE

United Kingdom

Thomson
Fishleigh Road
Barnstaple
EX31 3UD, United Kingdom
Phone: +44 (0)1271 334 500
Fax: +44 (0)1271 334 501
E-mail: sales.uk@thomsonlinear.com

Germany

Thomson
Nürtinger Straße 70
72649 Wolfschlügen, Germany
Phone: +49 (0) 7022 504 100
Fax: +49 (0) 7022 504 405
E-Mail: sales.wolfschlügen@thomsonlinear.com

Sweden

Thomson
Box 9053
SE-291 09 Kristianstad, Sweden
Phone: +46 (0) 44-24 67 00
Fax: +46 (0) 44-24 40 85
E-mail: sales.scandinavia@thomsonlinear.com

Italy

Thomson
Largo Brughetti
I-20030 Bovisio Masciago, Italy
Phone: +39 0362 594260
Fax: +39 0362 594263
E-mail: info@thomsonlinear.it

France

Thomson
C.P. 80018
12, Rue Antoine Becquerel – Z.I. Sud
F-72026 Le Mans Cedex 2, France
Phone: +33 (0) 243 50 03 30
Fax: +33 (0) 243 50 03 39
E-mail: sales.france@thomsonlinear.com

Spain

Thomson
Rbla Badal, 29-31 7th, 1st
08014 Barcelona, Spain
Phone: +34 (0) 9329 80278
Fax: +34 (0) 9329 80278
E-mail: josep.estaran@thomsonlinear.com

ASIA

China

Thomson
Room 2205, Scitech Tower
No 22 Jianguomenwai Avenue, Beijing100004,
China
Phone: +86 400 666 1802
Fax: +86 10 6515 0263
Email: sales.china@thomsonlinear.com

Japan

Thomson
2F, Sigma Hatchobori Bldg
2-7-1 Hatchobori Chuo-ku
Tokyo 104-0032, Japan
Phone: +81-3-6222-1051
Fax: +81-3-6222-1055
E-mail: info@danahermotion.co.jp

Asia Pacific

Thomson
Unit A, 16 Floor, 169 Electric Road
Manulife Tower, North Point, Hong Kong
Phone: +852 2503 6581
Fax: +852 2571 8585
E-mail: richard.teo@thomsonlinear.com

Korea

Thomson
#407 Kinstower
Bundang Inteligy1, 25-1
Jeongja-dong, Bundang-gu
Seongnam-city, Kunggi-do, Korea
Phone: +91 22 28294058
Fax: +91 22 28394036
Email: aaron.kim@danahermotion.com

India

Thomson
Unit No 2, SDF 1
Seepz Andheri, Mumbai 400 096, India
Phone: +91 22 28294058
Fax: +91 22 28394036
E-mail: richard.teo@thomsonlinear.com